

CONTROL SURVEY DATA:
SEE SURVEY DATA SHEETS

FOR INDEX OF SHEETS
AND STANDARDS,
SEE SHEET 2

STATE OF OKLAHOMA
DEPARTMENT OF TRANSPORTATION
**PLAN OF PROPOSED
INTERSTATE HIGHWAY**
PROJECT NO. J3-3788(011)
INTERCHANGE
US-75: MAINLINE FROM I-44 INTERCHANGE
TO 41st STREET INTERCHANGE
TULSA COUNTY
CONTROL SECTION 75-72-18
STATE JOB NO. 33788(11)

MANDATORY TIE:
THIS PROJECT IS MANDATORILY
TIED TO J/P 33788(08)

BRIDGE 'F1' LOCATION NO. xxxx xxxxx; NEW NBI NO. xxxxx
BRIDGE 'F2' LOCATION NO. xxxx xxxxx; NEW NBI NO. xxxxx
BRIDGE 'G1' LOCATION NO. 7218 1053EX; EXISTING NBI NO. 18254; NEW NBI NO. xxxxx
BRIDGE 'G2' LOCATION NO. 7218 1053WX; EXISTING NBI NO. 18255; NEW NBI NO. xxxxx
BRIDGE 'J1' LOCATION NO. 7218 1020EX; EXISTING NBI NO. 18267; NEW NBI NO. xxxxx
BRIDGE 'J2' LOCATION NO. 7218 1020WX; EXISTING NBI NO. 18268; NEW NBI NO. xxxxx
BRIDGE 'J3' LOCATION NO. xxxx xxxxx; NEW NBI NO. xxxxx
BRIDGE 'L' LOCATION NO. xxxx xxxxx; NEW NBI NO. xxxxx
BRIDGE 'M' LOCATION NO. xxxx xxxxx; NEW NBI NO. xxxxx
BRIDGE 'P' LOCATION NO. xxxx xxxxx; NEW NBI NO. xxxxx

BRIDGE 'F1' US-75 NB	BEGIN STA. 573+93.76 BRIDGE LENGTH 107.00' END STA. 575+00.76
BRIDGE 'F2' US-75 SB	BEGIN STA. 574+02.24 BRIDGE LENGTH 107.00' END STA. 575+09.24
BRIDGE 'G1' US-75 NB	BEGIN STA. 599+08.45 BRIDGE LENGTH 185.66' END STA. 600+94.11
BRIDGE 'G2' US-75 SB	BEGIN STA. 599+10.44 BRIDGE LENGTH 185.66' END STA. 600+96.10
BRIDGE 'J1' US-75 NB	BEGIN STA. 582+04.12 BRIDGE LENGTH 163.00' END STA. 583+67.12
BRIDGE 'J2' US-75 SB	BEGIN STA. 582+04.12 BRIDGE LENGTH 163.00' END STA. 583+67.12
BRIDGE 'J3' RAMP E2	BEGIN STA. 82+02.35 BRIDGE LENGTH 163.70' END STA. 83+66.05
BRIDGE 'L' RAMP E3	BEGIN STA. 77+87.08 BRIDGE LENGTH 1153.06' END STA. 89+40.14
BRIDGE 'M' RAMP E4	BEGIN STA. 171+47.00 BRIDGE LENGTH 329.00' END STA. 174+76.00
BRIDGE 'P' RAMP E8	BEGIN STA. 61+73.53 BRIDGE LENGTH 1451.78' END STA. 76+25.31

DESIGN DATA	I-44	US-75
AADT 2020	81,240	54,630
AADT 2045	101,000	71,000
K (DHV/AADT)	10%	10%
D	55%	60%
T (% DHV)	12%	6%
T (% AADT)	14%	8%
T (% AADT)	10%	4%
V	65 MPH	65 MPH
20yr FLEX ESALS	65.25M	19.63M

- CONVENTIONAL SYMBOLS**
- PROPOSED ROAD
 - RAILROADS
 - RANGE & TOWNSHIP
 - SECTION LINES
 - QUARTER SECTION LINES
 - FENCES
 - GROUND LINE
 - EXISTING ROADS
 - BASE LINE
 - GRADE LINES
 - TELEPHONE & TELEGRAPH
 - POWER LINES
 - BUILDINGS
 - TUG
 - TELEPHONE UNDERGROUND
 - SANITARY SEWER
 - GAS LINE
 - WATER LINE
 - DRAINAGE STRUCTURES - IN PLACE
 - DRAINAGE STRUCTURES - NEW
 - RIGHT-OF-WAY LINES - EXISTING
 - RIGHT-OF-WAY LINES - NEW
 - CONTROLLED ACCESS
 - RIGHT-OF-WAY FENCE

SCALES
PLAN 1" = 50'
PROFILE HOR. 1" = 50'
VER. 1" = 5'
LAYOUT MAP 1" = 1500'

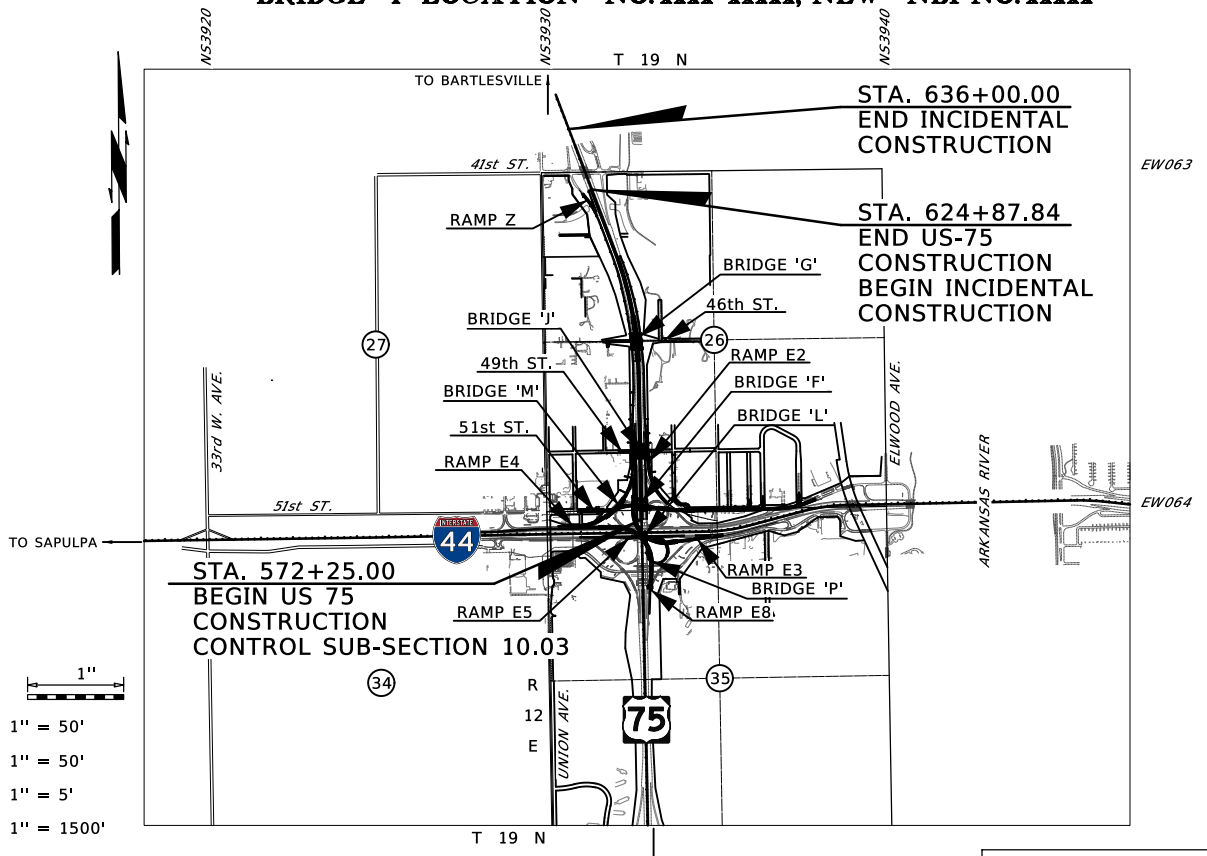

NOTE:
PROJECT EXTENTS WITHIN CITY LIMITS
OF THE CITY OF TULSA.

NOTE:
PROJECT LENGTH BASED ON US-75 SB

ROADWAY LENGTH _____ 4,807.18 FT. 0.910 MI.
BRIDGE LENGTH _____ 455.66 FT. 0.086 MI.
PROJECT LENGTH _____ 0.996 MI.
EQUATIONS: NONE
EXCEPTIONS: NONE

CERTIFICATE OF AUTHORIZATION NO. 7569 P.E., L.S. RENEWAL DATE 6-30-22

Benham Design, LLC
One West Third Street, Suite 200
Tulsa, Oklahoma 74103
(918) 492-1600

Rhonda J. Dudeck, P.E.
OK P.E. NO. 16476
PROJECT ENGINEER
DATE: _____

OKLAHOMA DEPARTMENT OF TRANSPORTATION

DATE APPROVED _____

BY _____

CHIEF ENGINEER

SWO 5443(3) PROJECT NO. J3-3788(011)

COUNTY TULSA HIGHWAY US-75 SHEET NO. 0001

DEPARTMENT OF TRANSPORTATION
FEDERAL HIGHWAY ADMINISTRATION

DATE APPROVED _____

BY _____

DIVISION ADMINISTRATOR

P:\FDB\1650-TUL\CV\40035_000T_EC2223A_US75_Design-Work\King\Civil\MicroStation\33788(11)\WP5\Sheets\33788(11)-Title_Sheet.dgn

INDEX OF SHEETS

GENERAL

0001 TITLE SHEET
0002 INDEX
0003 - 0015 TYPICAL SECTION (1) - (13)

BRIDGE F1

B001 - B002 GENERAL PLAN AND ELEVATION
B003 SUPERSTRUCTURE DETAILS

BRIDGE F2

B004 - B005 GENERAL PLAN AND ELEVATION
B006 SUPERSTRUCTURE DETAILS

BRIDGE G1

B007 - B008 GENERAL PLAN AND ELEVATION
B009 SUPERSTRUCTURE DETAILS
B010 CONSTRUCTION PHASING

BRIDGE G2

B011 - B012 GENERAL PLAN AND ELEVATION
B013 SUPERSTRUCTURE DETAILS
B014 CONSTRUCTION PHASING

BRIDGE J1

B015 - B016 GENERAL PLAN AND ELEVATION
B017 SUPERSTRUCTURE DETAILS

BRIDGE J2

B018 - B019 GENERAL PLAN AND ELEVATION
B020 SUPERSTRUCTURE DETAILS
B021 CONSTRUCTION PHASING

BRIDGE J3

B022 - B023 GENERAL PLAN AND ELEVATION
B024 SUPERSTRUCTURE DETAILS

BRIDGE L

B025 - B028 GENERAL PLAN AND ELEVATION
B029 SUPERSTRUCTURE DETAILS

BRIDGE M

B030 - B031 GENERAL PLAN AND ELEVATION
B032 SUPERSTRUCTURE DETAILS

BRIDGE P

B033 - B037 GENERAL PLAN AND ELEVATION
B038 SUPERSTRUCTURE DETAILS

ROADWAY

R001 - R008 DRAINAGE MAP (1) - (8)
R009 DRAINAGE STRUCTURE DESIGN RECORD
R010 - R011 STORM SEWER DESIGN RECORD (1) - (2)
R012 STORMWATER MANAGEMENT PLAN
R013 - R022 GEOMETRIC DATA (1) - (10)
R023 PLAN KEY MAP (MAINLINE)
R024 - R033 PLAN AND PROFILE - US-75 (1) - (10)
R034 PLAN KEY MAP (RAMPS)
R035 - R036 PLAN & PROFILE - RAMP E2 (11) - (12)
R037 - R042 PLAN AND PROFILE - RAMP E3 (13) - (18)
R043 - R046 PLAN AND PROFILE - RAMP E4 (19) - (22)
R047 PLAN & PROFILE - RAMP E5 (23)
R048 - R051 PLAN AND PROFILE - RAMP E8 (24) - (27)
R052 PLAN & PROFILE - RAMP Z (28)
R053 PLAN KEY MAP (LOCAL ROADS)
R054 - R056 PLAN & PROFILE - 51ST STREET (29) - (31)
R057 PLAN & PROFILE - 49TH STREET (32)
R058 PLAN & PROFILE - 46TH STREET (33)
R059 PLAN & PROFILE - OLYMPIA AVENUE & LAWTON AVENUE (34)
R060 PLAN & PROFILE - JACKSON AVENUE & INDIAN AVENUE (35)

SURVEY DATA

S001 - S023 SURVEY DATA SHEET (1) - (23)

TRAFFIC

T001 - T017 SIGNING & MARKING PLANS
T018 - T019 LIGHTING PLANS
T020 - T033 SUGGESTED CONSTRUCTION SEQUENCE (1) - (14)

CROSS SECTIONS

X001 - X013 CROSS SECTIONS - US-75
X014 - X022 CROSS SECTIONS - RAMP E2
X023 - X029 CROSS SECTIONS - RAMP E3
X030 - X043 CROSS SECTIONS - RAMP E4
X044 - X053 CROSS SECTIONS - RAMP E5
X054 - X064 CROSS SECTIONS - RAMP E8
X065 - X073 CROSS SECTIONS - RAMP Z
X074 - X108 CROSS SECTIONS - 51ST STREET
X109 - X113 CROSS SECTIONS - 49TH STREET
X114 - X118 CROSS SECTIONS - 46TH STREET

THE FOLLOWING ODOT STANDARDS WILL BE REQUIRED

ROADWAY TRAFFIC CONTROL TRAFFIC LIGHTING TRAFFIC SIGNAL TRAFFIC SIGNING TRAFFIC SAFETY BRIDGE

TO BE ADDED AT A LATER DATE



RESPONSIBLE FOR:
SHEETS 0003-0015, R001-R060



RESPONSIBLE FOR:
SHEETS B025-B029; B033-B038



RESPONSIBLE FOR:
SHEETS B001-B024; B030-B032

DESIGN			OKLAHOMA DEPARTMENT OF TRANSPORTATION
DRAWN			
CHECKED			
APPROVED			
SQUAD			
INDEX			
COUNTY	TULSA	HIGHWAY	US-75 STATE JOB NO. 33788(11) SHEET NO. 0002

3/4/2021

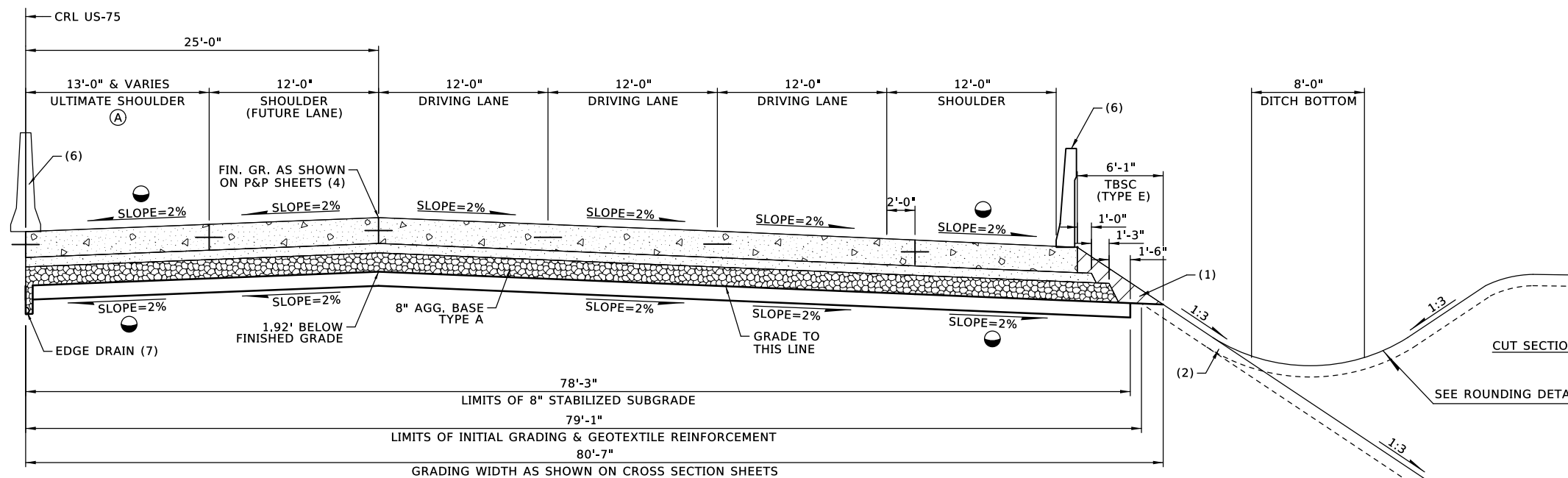

PAVEMENT REQUIREMENT			
PAVT. STRUCTURE	DRIVING LANES	PAVED INSIDE SHOULDER	PAVED OUTSIDE SHOULDER
SURFACE COURSE	12" DOWEL JOINTED P.C. CONCRETE	12" DOWEL JOINTED P.C. CONCRETE	12" TIED P.C. CONCRETE
BASE COURSE	3" SUPERPAVE TYPE S3 (PG 64-22 OK)	3" SUPERPAVE TYPE S3 (PG 64-22 OK)	3" SUPERPAVE TYPE S3 (PG 64-22 OK)

TYPICAL SECTION NO. 1: US-75 3-LANE HALF SECTION

NTS
 CRL US-75: STA. 572+25.00 TO STA. 573+69.02 (SB) (OPPOSITE HAND)
 CRL US-75: STA. 575+47.30 TO STA. 581+74.12 (SB) (OPPOSITE HAND)
 CRL US-75: STA. 583+97.12 TO STA. 585+54.41 (SB) (OPPOSITE HAND)
 CRL US-75: STA. 598+60.00 TO STA. 598+72.70 (NB)
 CRL US-75: STA. 601+27.25 TO STA. 603+00.00 (NB)

VARIABLE WIDTH TABLE			
SECTION		WIDTH	STATION LIMITS
1	A	7'-2" TO 7'-6"	572+25.00 TO 573+69.02 (OPPOSITE HAND)
1	A	7'-6" TO 13'-0"	575+51.39 TO 577+76.39 (OPPOSITE HAND)

US-75 INSIDE AND OUTSIDE SHOULDER CROSS SLOPE TRANSITION FROM -2.00% TO -4.00% BETWEEN STA. 583+97.12 AND STA. 585+08.96

PAVEMENT DESIGN HAS NOT BEEN COMPLETED. SECTION USED FOR COST ESTIMATING PURPOSES.

- (1) BACKFILL NOTE:
TO BE BACKFILLED AS PART OF THE FINISHING OPERATIONS. QUANTITY IS MEASURED IN TBSC TYPE E.
- (2) TOPSOIL NOTE:
THE CONTRACTOR SHALL STRIP ALL OF THE AVAILABLE TOPSOIL, STOCKPILE IT, AND PLACE IT BACK ON THE SECTION IN ACCORDANCE WITH SECTION 205 OF THE STANDARD SPECIFICATIONS. RESERVED TOPSOIL SHALL BE SPREAD FIRST ON THE COMPLETED SLOPES OF THE CUT SECTIONS AND THE REMAINDER ON COMPLETED FILL SLOPES OR OTHER PRIORITY AREAS LOCATED BY THE ENGINEER. ALL ADDITIONAL COSTS ASSOCIATED WITH OPERATIONS SHALL BE INCLUDED IN THE PAY ITEM FOR SALVAGED TOPSOIL, LUMP SUM.

THE GRADING LINE AS SHOWN ON THE TYPICAL AND CROSS SECTIONS IS TO THE TOP OF THE TOPSOIL. EARTHWORK QUANTITIES WERE NOT ADJUSTED FOR SALVAGE AND THE TOPSOIL QUANTITY IS INCLUDED IN THE MASS LINE BALANCE.
- (3) DISTANCE MEASURED VERTICALLY FROM EDGE OF FINISHED GRADE SHOULDER.
- (4) ROTATE SUPERELEVATION ABOUT PROFILE GRADE POINT.
- (5) BACKFILL NOTE:
TO BE BACKFILLED AS PART OF THE FINISHING OPERATIONS. MATERIAL TO BE STANDARD FILL MATERIAL AND COST INCLUDED IN OTHER ITEMS.
- (6) CONSTRUCT F-SHAPED BARRIER PER ODOT STD. FSHP-42-2-00E OR CONSTRUCT MEDIAN BARRIER PER ODOT STD. CLB-1-2. REFER TO THE BARRIER SUMMARY ON SHEET XXX FOR SPECIFIC LOCATION AND TYPE.
- (7) OUTLET EDGE DRAIN INTO STORM SEWER INLETS. COST TO BE INCLUDED IN OTHER ITEMS OF WORK.

DESIGN		OKLAHOMA DEPARTMENT OF TRANSPORTATION
DRAWN		
CHECKED		
APPROVED		
SQUAD		
TYPICAL SECTION (1)		
COUNTY - TULSA	HIGHWAY US-75	STATE JOB NO. 33788(11) SHEET NO. 0003

P:\FDB\1650-TUL\CIV\40035-000T_EC223A_US75\Design-Working\CIV\MicroStation\33788\1650\Sheets\33788\1-Typical.dgn

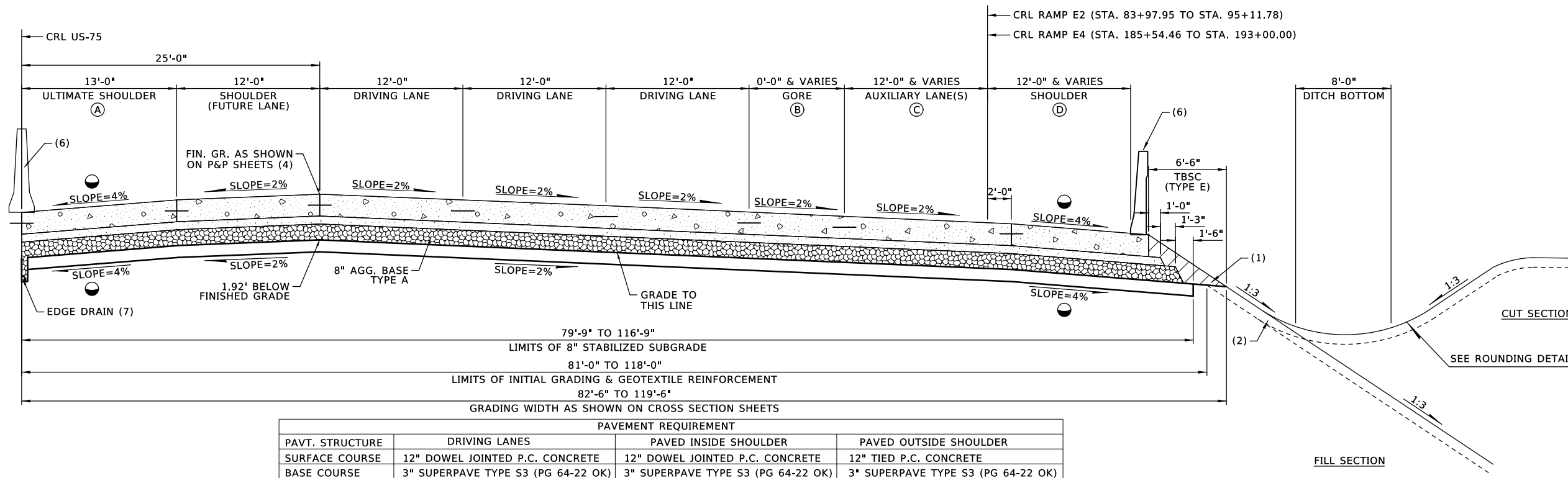

PAVEMENT REQUIREMENT			
PAVT. STRUCTURE	DRIVING LANES	PAVED INSIDE SHOULDER	PAVED OUTSIDE SHOULDER
SURFACE COURSE	12" DOWEL JOINTED P.C. CONCRETE	12" DOWEL JOINTED P.C. CONCRETE	12" TIED P.C. CONCRETE
BASE COURSE	3" SUPERPAVE TYPE S3 (PG 64-22 OK)	3" SUPERPAVE TYPE S3 (PG 64-22 OK)	3" SUPERPAVE TYPE S3 (PG 64-22 OK)

TYPICAL SECTION NO. 2: US-75 3-LANE HALF SECTION W/ AUXILIARY LANE(S)

NTS

CRL US-75: STA. 572+25.00 TO STA. 573+53.66 (NB)
 CRL US-75: STA. 575+33.98 TO STA. 581+74.12 (NB)
 CRL US-75: STA. 585+54.41 TO STA. 598+76.21 (SB) (OPPOSITE HAND)
 CRL US-75: STA. 601+32.99 TO STA. 603+00.00 (SB) (OPPOSITE HAND)
 CRL US-75: STA. 583+97.12 TO STA. 598+60.00 (NB)

VARIABLE WIDTH TABLE			
SECTION		WIDTH	STATION LIMITS
2	A	7'-2" TO 7'-6"	572+25.00 TO 573+53.66
2	A	7'-6"	575+33.98 TO 575+51.39
2	A	7'-6" TO 13'-0"	575+51.39 TO 577+76.39
2	B	25'-6" TO 0'-0"	583+97.12 TO 589+69.65
2	B	24'-0" TO 0'-0"	585+54.41 TO 590+70.40 (OPPOSITE HAND)
2	C	12'-0" TO 1'-6"	579+10.76 TO 581+74.12
2	C	15'-0" TO 12'-0"	583+97.12 TO 589+69.65
2	C	24'-0" TO 12'-0"	585+54.41 TO 593+00 (OPPOSITE HAND)
2	D	10'-0"	583+97.12 TO 585+85.08
2	D	10'-0" TO 12'-0"	585+85.08 TO 586+35.01
2	D	10'-0"	585+54.41 TO 586+20.33 (OPPOSITE HAND)
2	D	10'-0" TO 12'-0"	586+20.33 TO 587+20.43 (OPPOSITE HAND)

REFER TO SHEET 0003 FOR TYPICAL SECTION NOTES

PAVEMENT DESIGN HAS NOT BEEN COMPLETED. SECTION USED FOR COST ESTIMATING PURPOSES.

US-75 INSIDE AND OUTSIDE SHOULDER CROSS SLOPE TRANSITION FROM -2.00% TO -4.00% BETWEEN STA. 583+97.12 AND STA. 585+08.96

DESIGN		OKLAHOMA DEPARTMENT OF TRANSPORTATION
DRAWN		
CHECKED		
APPROVED		
SQUAD		
TYPICAL SECTION (2)		
COUNTY - TULSA	HIGHWAY US-75	STATE JOB NO. 33788(11) SHEET NO. 0004

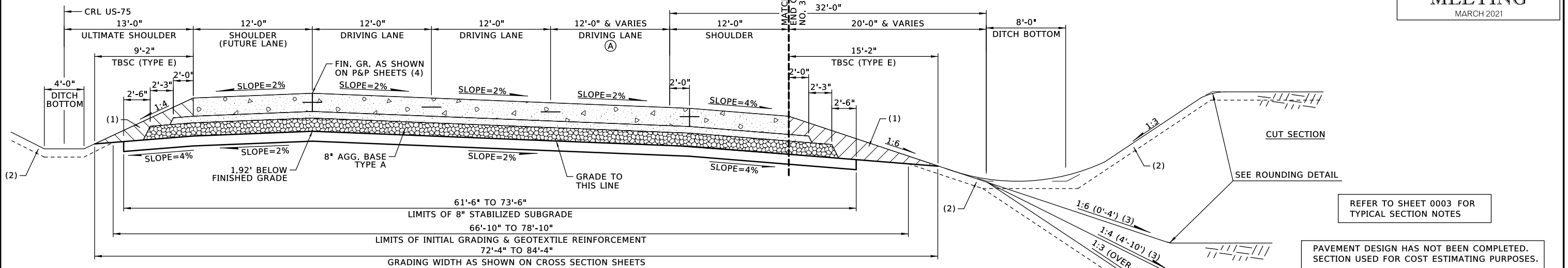

PAVEMENT REQUIREMENT			
PAVT. STRUCTURE	DRIVING LANES	PAVED INSIDE SHOULDER	PAVED OUTSIDE SHOULDER
SURFACE COURSE	12" DOWEL JOINTED P.C. CONCRETE	12" DOWEL JOINTED P.C. CONCRETE	12" TIED P.C. CONCRETE
BASE COURSE	3" SUPERPAVE TYPE S3 (PG 64-22 OK)	3" SUPERPAVE TYPE S3 (PG 64-22 OK)	3" SUPERPAVE TYPE S3 (PG 64-22 OK)

TYPICAL SECTION NO. 3: US-75 3-LANE HALF SECTION (DIVIDED)

CRL US-75: STA. 610+97.84 TO STA. 619+47.84 (SB) (OPPOSITE HAND)
CRL US-75: STA. 603+00.00 TO STA. 611+07.84 (NB)

VARIABLE WIDTH TABLE			
SECTION	WIDTH	STATION LIMITS	
3	A	12'-0" TO 0'-0"	605+07.84 TO 611+07.84
3	A	0'-0"	610+97.84 TO 619+47.84 (OPPOSITE HAND)

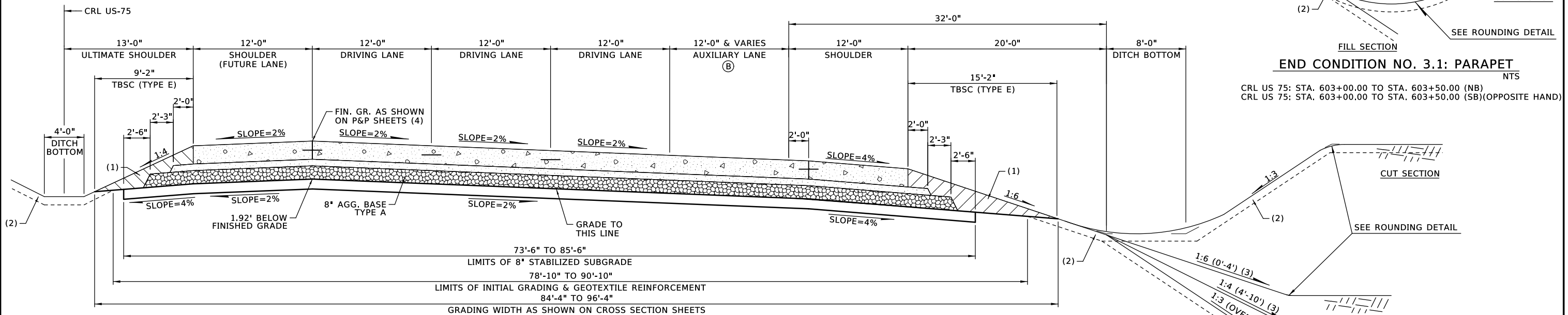

PAVEMENT REQUIREMENT			
PAVT. STRUCTURE	DRIVING LANES	PAVED INSIDE SHOULDER	PAVED OUTSIDE SHOULDER
SURFACE COURSE	12" DOWEL JOINTED P.C. CONCRETE	12" DOWEL JOINTED P.C. CONCRETE	12" TIED P.C. CONCRETE
BASE COURSE	3" SUPERPAVE TYPE S3 (PG 64-22 OK)	3" SUPERPAVE TYPE S3 (PG 64-22 OK)	3" SUPERPAVE TYPE S3 (PG 64-22 OK)

TYPICAL SECTION NO. 4: US-75 3-LANE HALF SECTION W/AUXILIARY LANE (DIVIDED)

CRL US-75: STA. 603+00.00 TO STA. 610+97.84 (SB) (OPPOSITE HAND)

VARIABLE WIDTH TABLE			
SECTION	WIDTH	STATION LIMITS	
4	B	12'-0" TO 0'-0"	607+97.84 TO 610+97.84 (OPPOSITE HAND)

DESIGN		OKLAHOMA DEPARTMENT OF TRANSPORTATION
DRAWN		
CHECKED		
APPROVED		
SQUAD		
TYPICAL SECTION (3)		
COUNTY - TULSA	HIGHWAY US-75	STATE JOB NO. 33788(08)
		SHEET NO. 0005

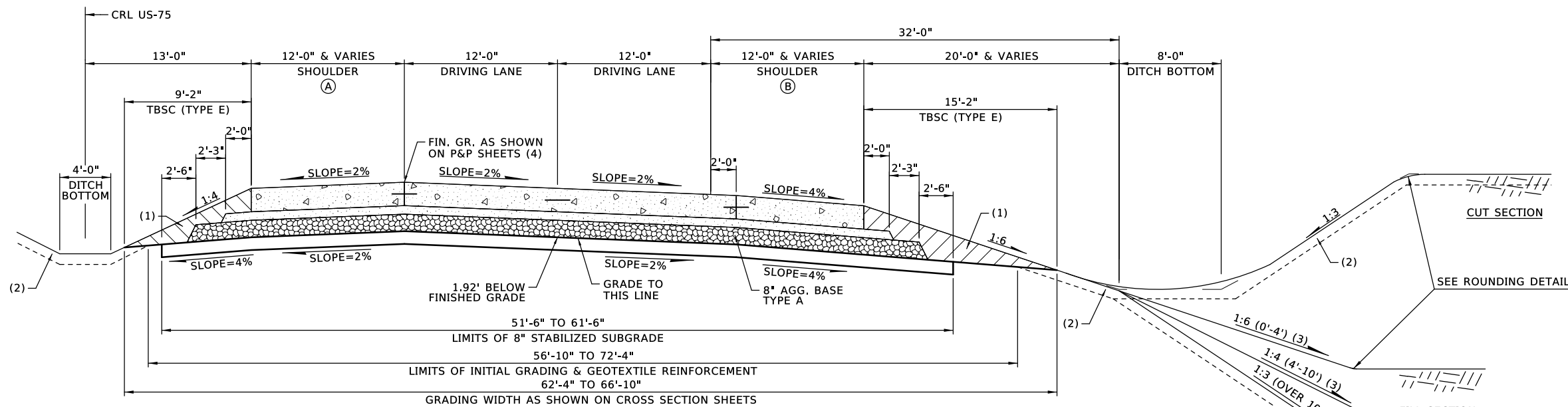

PAVEMENT REQUIREMENT			
PAVT. STRUCTURE	DRIVING LANES	PAVED INSIDE SHOULDER	PAVED OUTSIDE SHOULDER
SURFACE COURSE	12" DOWEL JOINTED P.C. CONCRETE	12" DOWEL JOINTED P.C. CONCRETE	12" TIED P.C. CONCRETE
BASE COURSE	3" SUPERPAVE TYPE S3 (PG 64-22 OK)	3" SUPERPAVE TYPE S3 (PG 64-22 OK)	3" SUPERPAVE TYPE S3 (PG 64-22 OK)

TYPICAL SECTION NO. 5: US-752-LANE HALF SECTION (DIVIDED)

CRL US-75: STA. 622+18.00 TO STA. 624+87.84 (SB) (OPPOSITE HAND)
CRL US-75: STA. 611+07.84 TO STA. 613+57.84 (NB)

VARIABLE WIDTH TABLE			
SECTION		WIDTH	STATION LIMITS
5	A	12'-0" TO 4'-0"	611+07.84 TO 613+57.84
5	A	12'-0" TO 4'-0"	623+07.51 TO 624+87.84 (OPPOSITE HAND)
5	B	12'-0" TO 10'-0"	611+07.84 TO 613+57.84
5	B	12'-0" TO 10'-0"	623+07.51 TO 624+87.84 (OPPOSITE HAND)

REFER TO SHEET 0003 FOR TYPICAL SECTION NOTES

PAVEMENT DESIGN HAS NOT BEEN COMPLETED. SECTION USED FOR COST ESTIMATING PURPOSES.

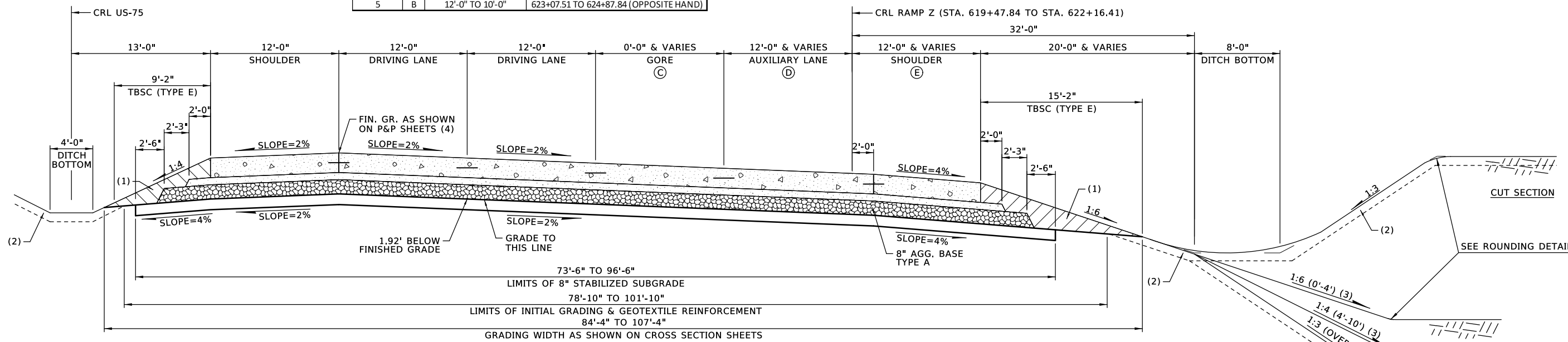

PAVEMENT REQUIREMENT			
PAVT. STRUCTURE	DRIVING LANES	PAVED INSIDE SHOULDER	PAVED OUTSIDE SHOULDER
SURFACE COURSE	12" DOWEL JOINTED P.C. CONCRETE	12" DOWEL JOINTED P.C. CONCRETE	12" TIED P.C. CONCRETE
BASE COURSE	3" SUPERPAVE TYPE S3 (PG 64-22 OK)	3" SUPERPAVE TYPE S3 (PG 64-22 OK)	3" SUPERPAVE TYPE S3 (PG 64-22 OK)

TYPICAL SECTION NO. 6: US-75 2-LANE HALF SECTION W/AUXILIARY LANE (DIVIDED)

CRL US-75: STA. 619+47.84 TO STA. 622+18.00 (SB) (OPPOSITE HAND)

VARIABLE WIDTH TABLE			
SECTION		WIDTH	STATION LIMITS
6	C	0'-0" TO 24'-0"	619+90.15 TO 622+18.00 (OPPOSITE HAND)
6	D	12'-0" TO 15'-0"	619+47.84 TO 621+29.66 (OPPOSITE HAND)
6	D	15'-0"	621+29.66 TO 622+18.00 (OPPOSITE HAND)
6	E	12'-0" TO 10'-0"	621+31.93 TO 621+81.57 (OPPOSITE HAND)
6	E	10'-0"	621+81.57 TO 622+18.00 (OPPOSITE HAND)

DESIGN		OKLAHOMA DEPARTMENT OF TRANSPORTATION
DRAWN		
CHECKED		
APPROVED		
SQUAD		
TYPICAL SECTION (4)		
COUNTY - TULSA	HIGHWAY US-75	STATE JOB NO. 33788(11) SHEET NO. 0006

3/4/2021

P:\FDB\1650 - TUL CIVIL\400315-000T_EC223A_US75\Design-Working\Civil\MicroStation\33788\11-F5\Sheets\3378811-Typical_04.dgn

3/4/2021

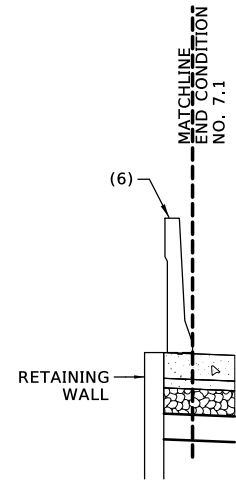

END CONDITION NO. 7.1: RETAINING WALL

CRL RAMP E3 STA. 75+21.37 TO STA. 77+57.08
NTS

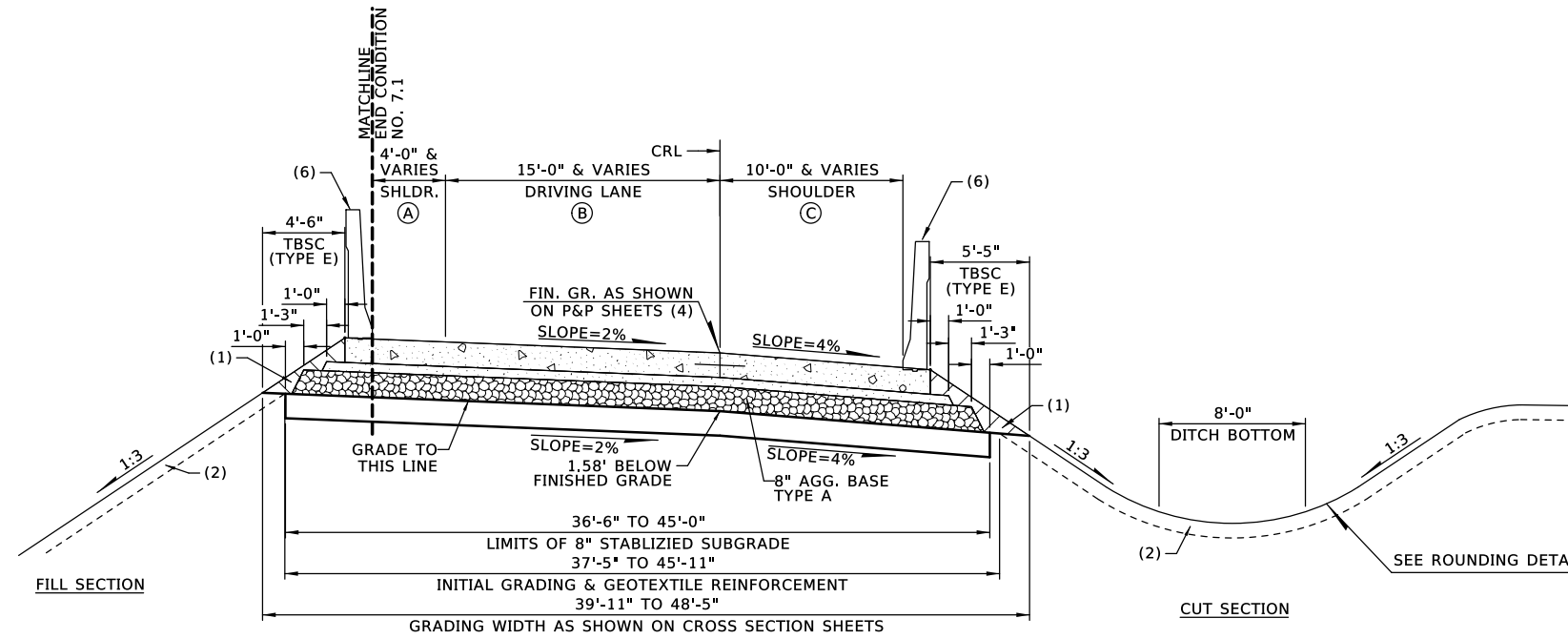

PAVEMENT REQUIREMENT			
PAVT. STRUCTURE	DRIVING LANES	PAVED INSIDE SHOULDER	PAVED OUTSIDE SHOULDER
SURFACE COURSE	8" DOWEL JOINTED P.C. CONCRETE	8" DOWEL JOINTED P.C. CONCRETE	8" DOWEL JOINTED P.C. CONCRETE
BASE COURSE	3" SUPERPAVE TYPE S3 (PG 64-22 OK)	3" SUPERPAVE TYPE S3 (PG 64-22 OK)	3" SUPERPAVE TYPE S3 (PG 64-22 OK)

TYPICAL SECTION NO. 7: RAMP

CRL RAMP E2: STA. 73+78.50 TO STA. 81+71.29
CRL RAMP E3: STA. 75+21.37 TO STA. 77+57.08
CRL RAMP E3: STA. 89+75.14 TO STA. 95+05.50
NTS

VARIABLE WIDTH TABLE			
SECTION		WIDTH	STATION LIMITS
7	A	4'-0" TO 6'-0"	76+57.52 TO 77+57.08 (RAMP E3)
7	B	14'-5" TO 15'-0"	75+21.37 TO 75+73.70 (RAMP E3)
7	C	18'-5" TO 8'-0"	75+21.37 TO 77+57.08 (RAMP E3)

REFER TO SHEET 0003 FOR TYPICAL SECTION NOTES

PAVEMENT DESIGN HAS NOT BEEN COMPLETED. SECTION USED FOR COST ESTIMATING PURPOSES.

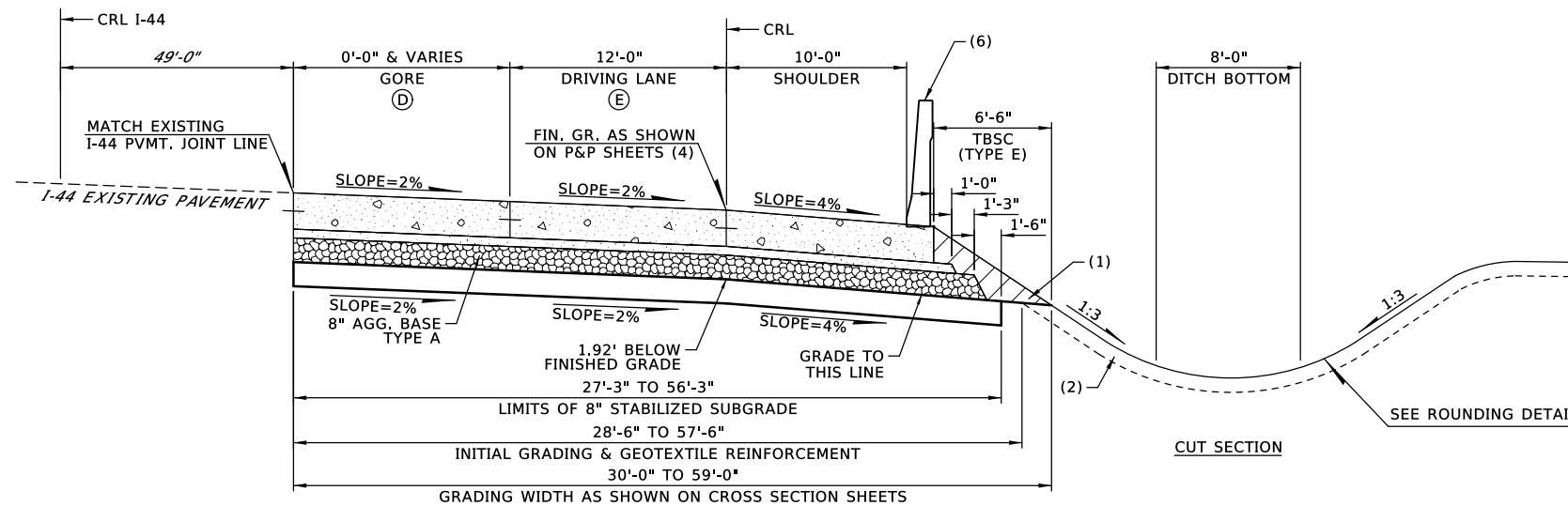

PAVEMENT REQUIREMENT			
PAVT. STRUCTURE	DRIVING LANES	PAVED INSIDE SHOULDER	PAVED OUTSIDE SHOULDER
SURFACE COURSE	12" DOWEL JOINTED P.C. CONCRETE	12" DOWEL JOINTED P.C. CONCRETE	12" TIED P.C. CONCRETE
BASE COURSE	3" SUPERPAVE TYPE S3 (PG 64-22 OK)	3" SUPERPAVE TYPE S3 (PG 64-22 OK)	3" SUPERPAVE TYPE S3 (PG 64-22 OK)

TYPICAL SECTION NO. 8: I-44 WIDENING

CRL RAMP E3: STA. 95+05.50 TO STA. 97+00.18
CRL RAMP E5: STA. 82+00.00 TO STA. 85+85.12
NTS

VARIABLE WIDTH TABLE			
SECTION		WIDTH	STATION LIMITS
8	D	26'-0" TO 14'-8"	95+05.50 TO 97+00.18 (RAMP E3)
8	E	15'-0"	95+05.50 TO 97+00.18 (RAMP E3)

DESIGN		OKLAHOMA DEPARTMENT OF TRANSPORTATION
DRAWN		
CHECKED		
APPROVED		TYPICAL SECTION (5)
SQUAD		
COUNTY - TULSA	HIGHWAY US-75	STATE JOB NO. 33788(11) SHEET NO. 0007

P:\FDB\1650-TUL\CIV\40035-000T_EC223A_US75\Design-Working\CIV\MicroStation\33788\1650\Sheets\33788\Typical_05.dgn

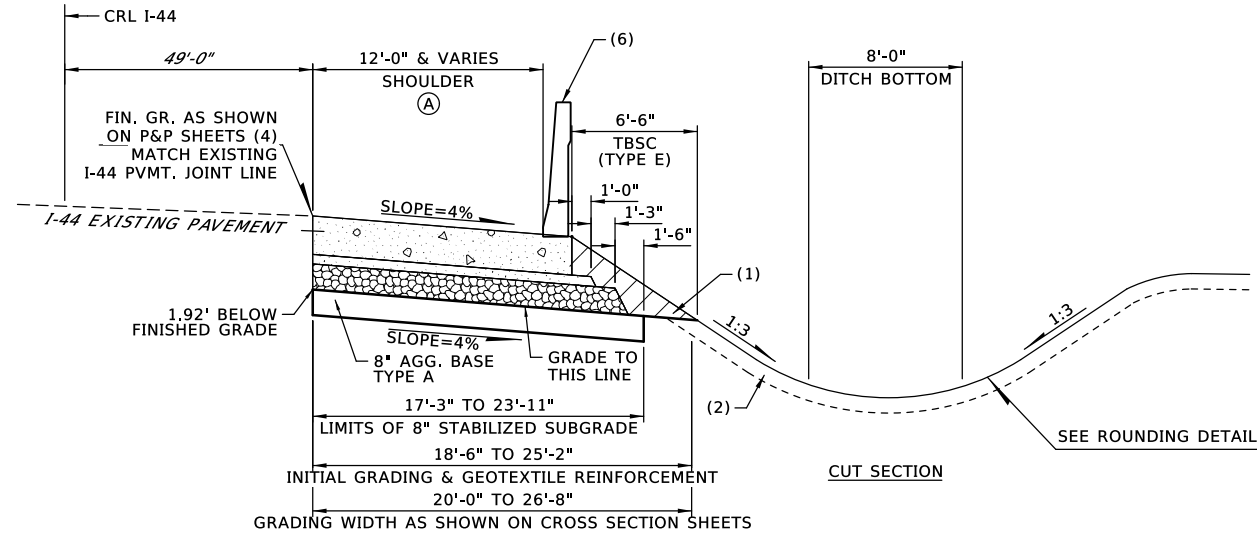

PAVEMENT REQUIREMENT	
PAVT. STRUCTURE	PAVED OUTSIDE SHOULDER
SURFACE COURSE	12" TIED P.C. CONCRETE
BASE COURSE	3" SUPERPAVE TYPE S3 (PG 64-22 OK)

TYPICAL SECTION NO. 9: I-44 WIDENING

CRL I-44: STA. 287+35.66 TO STA. 291+12.30 (EB)
 CRL I-44: STA. 292+89.77 TO STA. 295+20.32 (EB)

VARIABLE WIDTH TABLE			
SECTION	WIDTH	STATION LIMITS	
9	A	18'-8" TO 12'-0"	287+23.66 TO 291+12.30

REFER TO SHEET 0003 FOR TYPICAL SECTION NOTES

PAVEMENT DESIGN HAS NOT BEEN COMPLETED. SECTION USED FOR COST ESTIMATING PURPOSES.

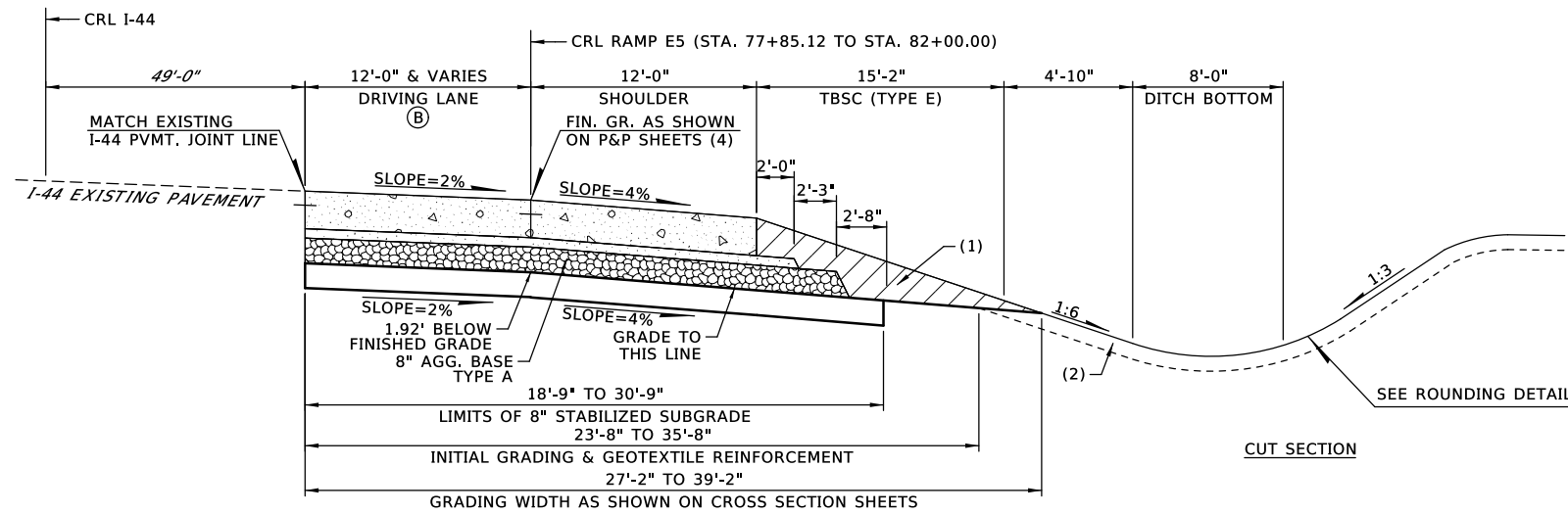

PAVEMENT REQUIREMENT		
PAVT. STRUCTURE	DRIVING LANES	PAVED OUTSIDE SHOULDER
SURFACE COURSE	12" DOWEL JOINTED P.C. CONCRETE	12" TIED P.C. CONCRETE
BASE COURSE	3" SUPERPAVE TYPE S3 (PG 64-22 OK)	3" SUPERPAVE TYPE S3 (PG 64-22 OK)

TYPICAL SECTION NO. 10: I-44 WIDENING

CRL I-44: STA. 274+84.88 TO STA. 277+85.12 (EB)
 CRL RAMP E5: STA. 77+85.12 TO STA. 82+00.00

VARIABLE WIDTH TABLE			
SECTION	WIDTH	STATION LIMITS	
10	B	0'-0" TO 12'-0"	274+84.88 TO 277+85.12 (I-44)

DESIGN		OKLAHOMA DEPARTMENT OF TRANSPORTATION
DRAWN		
CHECKED		
APPROVED		
SQUAD		
TYPICAL SECTION (6)		
COUNTY - TULSA	HIGHWAY US-75	STATE JOB NO. 33788(11) SHEET NO. 0008

3/4/2021

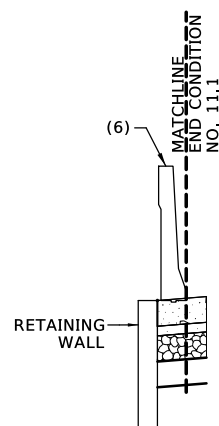

END CONDITION NO. 11.1: RETAINING WALL

NTS

CRL RAMP E4: STA. 169+00.27 TO STA. 170+70.17 LT.
CRL RAMP E4: STA. 180+00.00 TO STA. 181+72.10 LT.

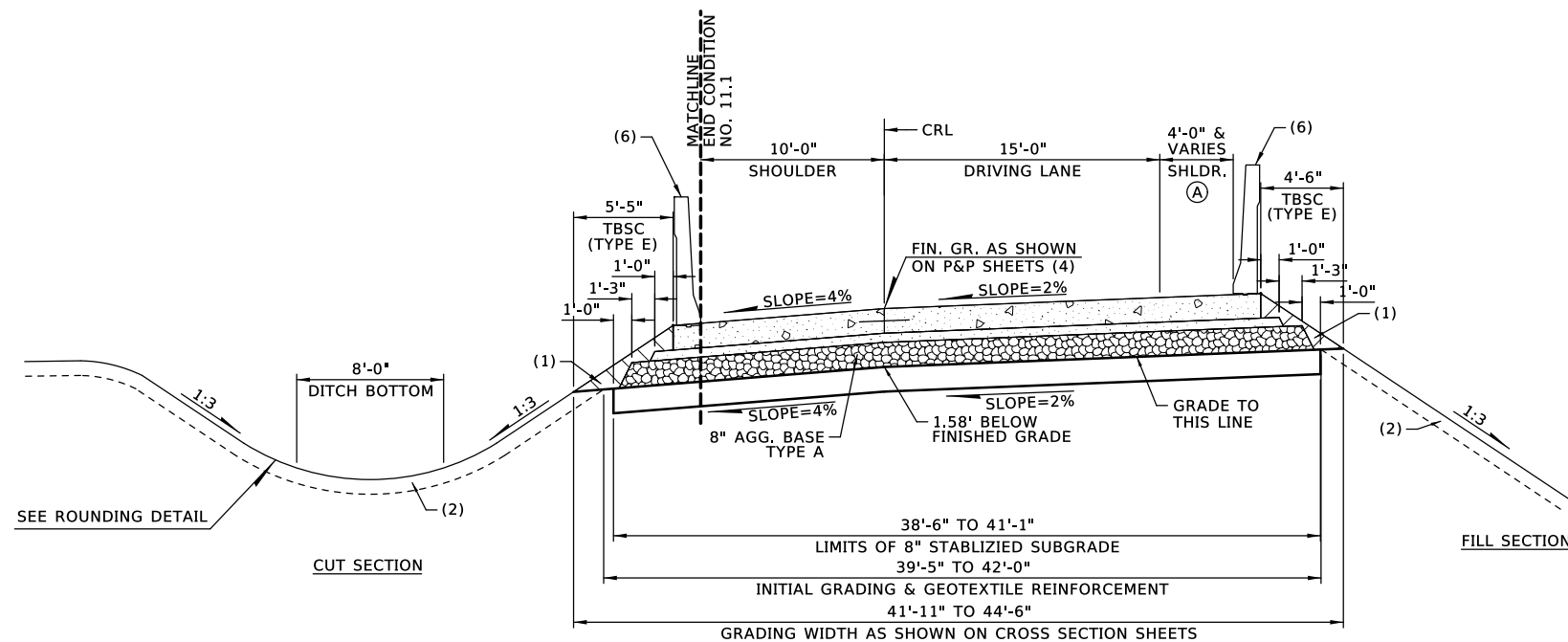

PAVEMENT REQUIREMENT			
PAVT. STRUCTURE	DRIVING LANES	PAVED INSIDE SHOULDER	PAVED OUTSIDE SHOULDER
SURFACE COURSE	8" DOWEL JOINTED P.C. CONCRETE	8" DOWEL JOINTED P.C. CONCRETE	8" DOWEL JOINTED P.C. CONCRETE
BASE COURSE	3" SUPERPAVE TYPE S3 (PG 64-22 OK)	3" SUPERPAVE TYPE S3 (PG 64-22 OK)	3" SUPERPAVE TYPE S3 (PG 64-22 OK)

TYPICAL SECTION NO. 11: RAMP

NTS

CRL RAMP E4: STA. 167+95.00 TO STA. 171+11.57
CRL RAMP E4: STA. 175+11.43 TO STA. 178+34.07

VARIABLE WIDTH TABLE			
SECTION	WIDTH	STATION LIMITS	
11	A	4'-0" TO 6'-7"	177+69.62 TO 178+34.07 (RAMP E4)

REFER TO SHEET 0003 FOR TYPICAL SECTION NOTES

PAVEMENT DESIGN HAS NOT BEEN COMPLETED. SECTION USED FOR COST ESTIMATING PURPOSES.

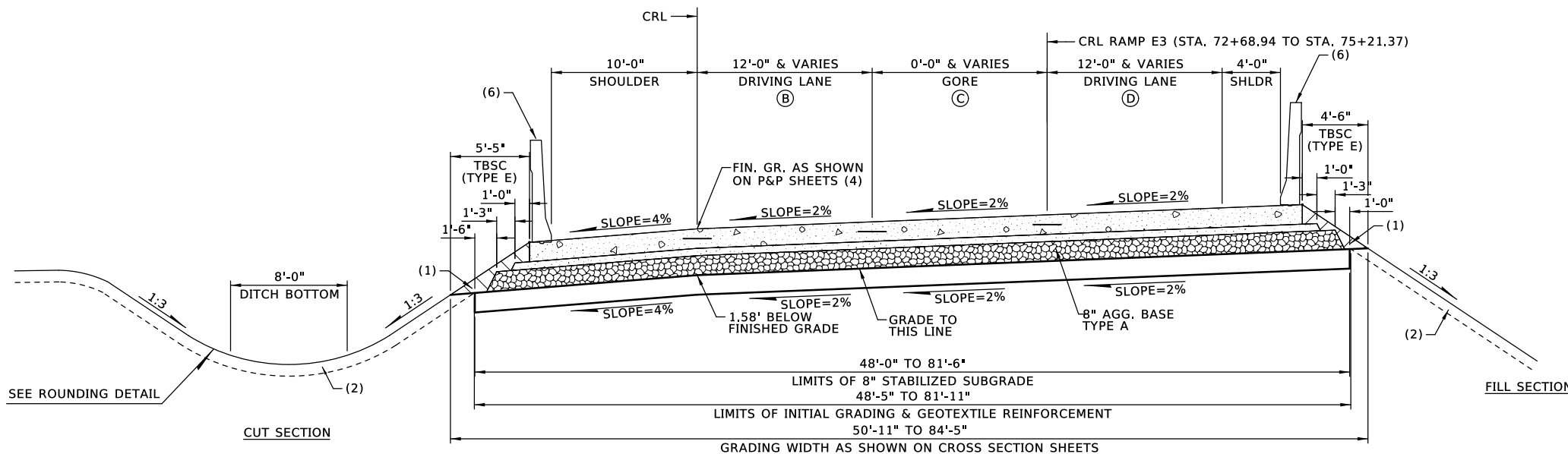

PAVEMENT REQUIREMENT			
PAVT. STRUCTURE	DRIVING LANES	PAVED INSIDE SHOULDER	PAVED OUTSIDE SHOULDER
SURFACE COURSE	8" DOWEL JOINTED P.C. CONCRETE	8" DOWEL JOINTED P.C. CONCRETE	8" DOWEL JOINTED P.C. CONCRETE
BASE COURSE	3" SUPERPAVE TYPE S3 (PG 64-22 OK)	3" SUPERPAVE TYPE S3 (PG 64-22 OK)	3" SUPERPAVE TYPE S3 (PG 64-22 OK)

TYPICAL SECTION NO. 12: RAMP

NTS

CRL RAMP E4: STA. 178+34.07 TO STA. 181+73.19
CRL RAMP E4: STA. 183+96.20 TO STA. 185+54.46

VARIABLE WIDTH TABLE			
SECTION	WIDTH	STATION LIMITS	
12	B	15'-0" TO 12'-0"	178+34.07 TO 180+82.81 (RAMP E4)
12	C	28'-0" TO 0'-0"	178+34.07 TO 180+37.81 (RAMP E4)
12	D	14'-6" TO 12'-0"	178+34.07 TO 179+84.39 (RAMP E4)

DESIGN		OKLAHOMA DEPARTMENT OF TRANSPORTATION
DRAWN		
CHECKED		
APPROVED		
SQUAD		
TYPICAL SECTION (7)		
COUNTY - TULSA	HIGHWAY US-75	STATE JOB NO. 33788(11) SHEET NO. 0009

P:\FDB\1650-TUL\CIV\40035-000T_EC223A_US75\Design-Working\CIV\MicroStation\33788\11\WP5\Sheets\3378811-Typical_07.dgn

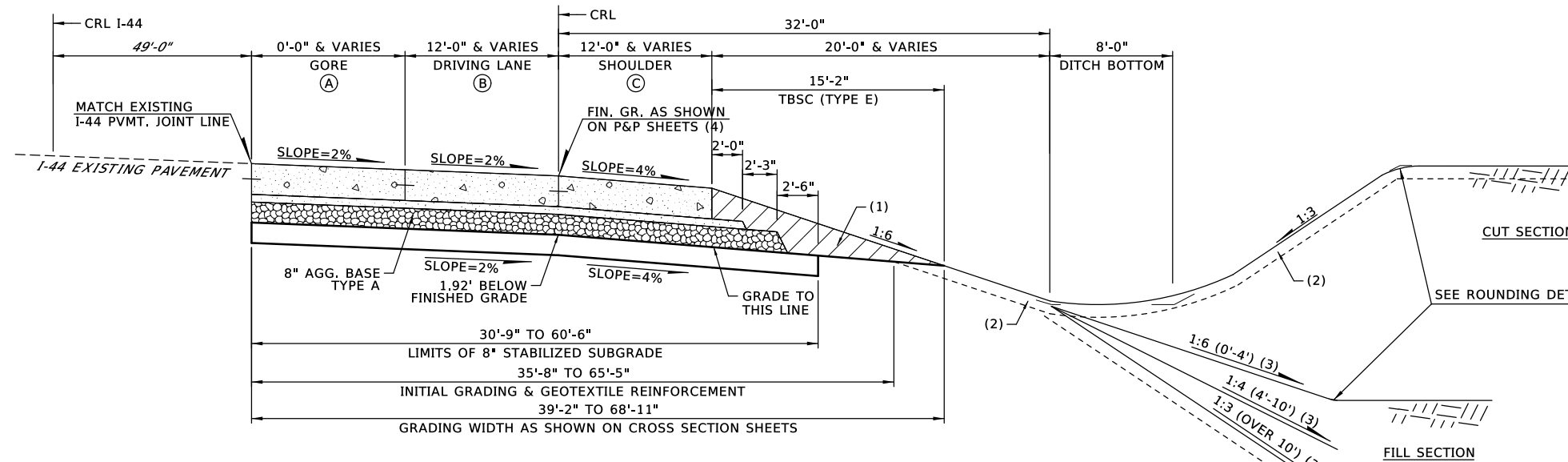

PAVEMENT REQUIREMENT			
PAVT. STRUCTURE	DRIVING LANES	PAVED INSIDE SHOULDER	PAVED OUTSIDE SHOULDER
SURFACE COURSE	12" DOWEL JOINTED P.C. CONCRETE	12" DOWEL JOINTED P.C. CONCRETE	12" TIED P.C. CONCRETE
BASE COURSE	3" SUPERPAVE TYPE S3 (PG 64-22 OK)	3" SUPERPAVE TYPE S3 (PG 64-22 OK)	3" SUPERPAVE TYPE S3 (PG 64-22 OK)

TYPICAL SECTION NO. 13: I-44 WIDENING

CRL RAMP E5: STA. 85+85.12 TO STA. 87+18.82
NTS

VARIABLE WIDTH TABLE			
SECTION		WIDTH	STATION LIMITS
13	A	0'-0" TO 26'-0"	86+21.79 TO 87+18.82 (RAMP E5)
13	B	12'-0" TO 19'-0"	85+85.12 TO 86+94.58 (RAMP E5)
13	B	19'-0" TO 17'-5"	86+94.58 TO 87+18.82 (RAMP E5)
13	C	12'-0" TO 10'-4"	86+94.58 TO 87+18.82 (RAMP E5)

REFER TO SHEET 0003 FOR TYPICAL SECTION NOTES

PAVEMENT DESIGN HAS NOT BEEN COMPLETED. SECTION USED FOR COST ESTIMATING PURPOSES.

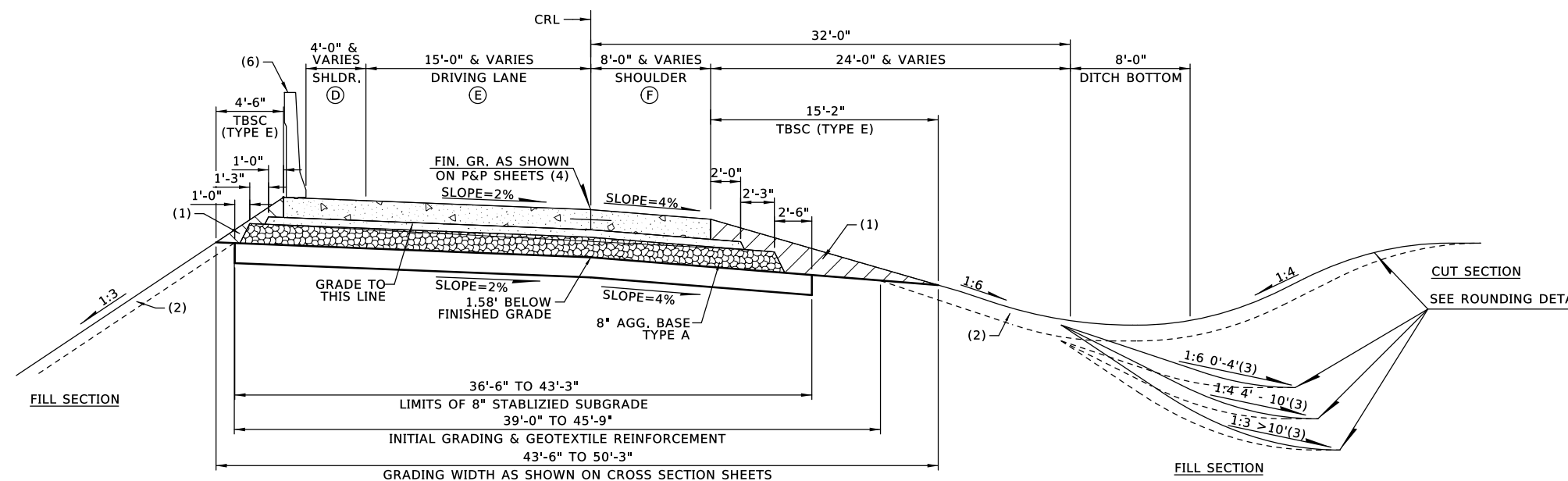

PAVEMENT REQUIREMENT			
PAVT. STRUCTURE	DRIVING LANES	PAVED INSIDE SHOULDER	PAVED OUTSIDE SHOULDER
SURFACE COURSE	8" DOWEL JOINTED P.C. CONCRETE	8" DOWEL JOINTED P.C. CONCRETE	8" DOWEL JOINTED P.C. CONCRETE
BASE COURSE	3" SUPERPAVE TYPE S3 (PG 64-22 OK)	3" SUPERPAVE TYPE S3 (PG 64-22 OK)	3" SUPERPAVE TYPE S3 (PG 64-22 OK)

TYPICAL SECTION NO. 14: RAMP

CRL RAMP E5: STA. 87+18.82 TO STA. 90+59.79
NTS

VARIABLE WIDTH TABLE			
SECTION		WIDTH	STATION LIMITS
14	D	4'-0" TO 2'-0"	90+05.00 TO 99+59.79 (RAMP E5)
14	E	17'-5" TO 15'-0"	87+18.82 TO 87+54.58 (RAMP E5)
14	F	10'-4" TO 8'-0"	87+18.82 TO 87+54.58 (RAMP E5)

DESIGN		OKLAHOMA DEPARTMENT OF TRANSPORTATION
DRAWN		
CHECKED		
APPROVED		
SQUAD		
TYPICAL SECTION (8)		
COUNTY - TULSA	HIGHWAY US-75	STATE JOB NO. 33788(11) SHEET NO. 0010

3/4/2021

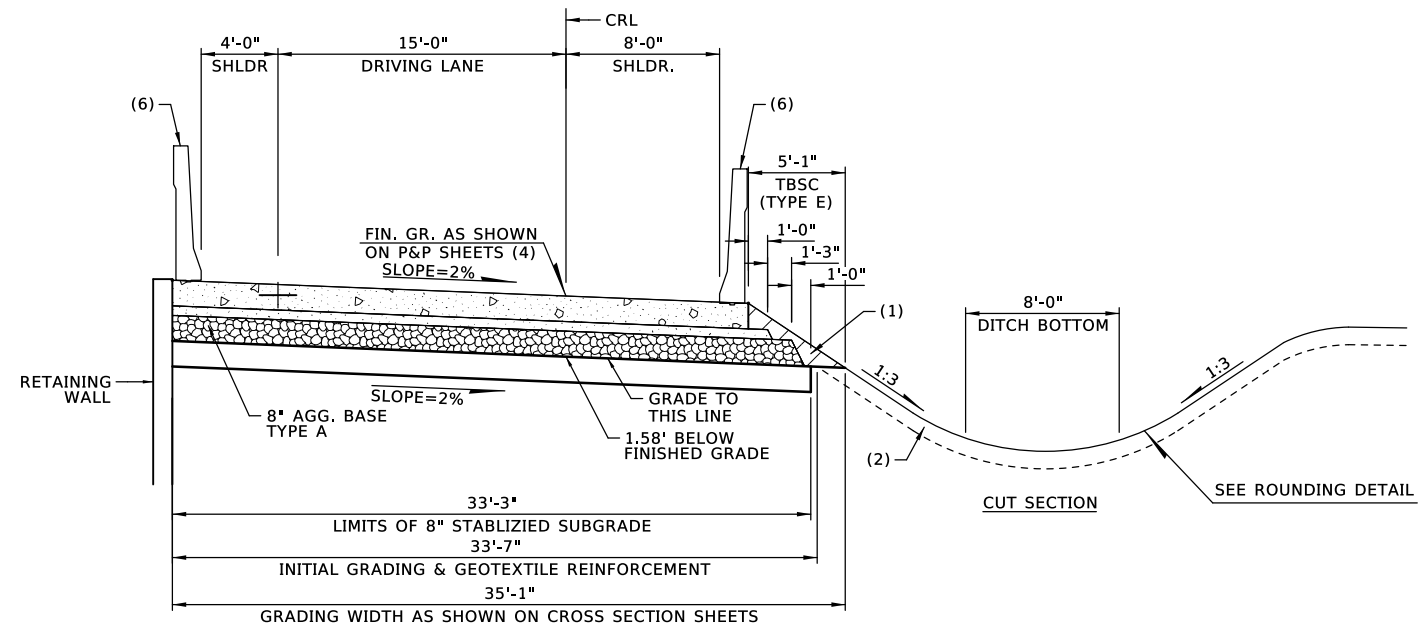

PAVEMENT REQUIREMENT			
PAVT. STRUCTURE	DRIVING LANES	PAVED INSIDE SHOULDER	PAVED OUTSIDE SHOULDER
SURFACE COURSE	8" DOWEL JOINTED P.C. CONCRETE	8" DOWEL JOINTED P.C. CONCRETE	8" DOWEL JOINTED P.C. CONCRETE
BASE COURSE	3" SUPERPAVE TYPE S3 (PG 64-22 OK)	3" SUPERPAVE TYPE S3 (PG 64-22 OK)	3" SUPERPAVE TYPE S3 (PG 64-22 OK)

TYPICAL SECTION NO. 15: RAMP

NTS
CRL RAMP E8: STA. 76+60.31 TO STA. 78+53.10 (OPPOSITE HAND)

REFER TO SHEET 0003 FOR TYPICAL SECTION NOTES

PAVEMENT DESIGN HAS NOT BEEN COMPLETED. SECTION USED FOR COST ESTIMATING PURPOSES.

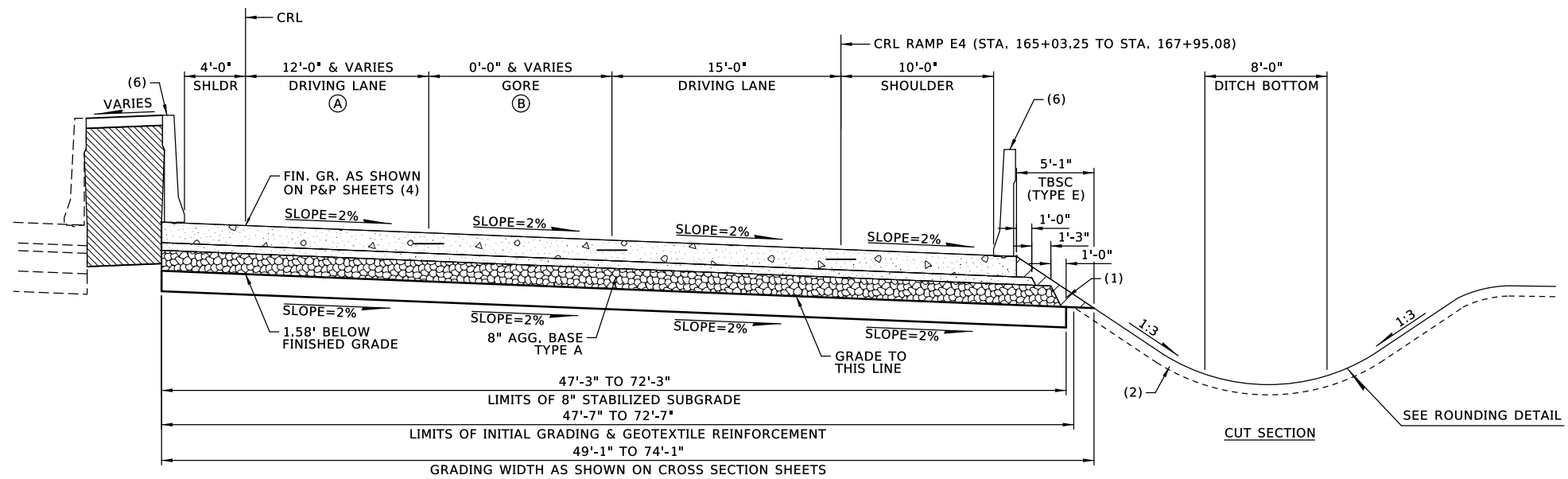

PAVEMENT REQUIREMENT			
PAVT. STRUCTURE	DRIVING LANES	PAVED INSIDE SHOULDER	PAVED OUTSIDE SHOULDER
SURFACE COURSE	8" DOWEL JOINTED P.C. CONCRETE	8" DOWEL JOINTED P.C. CONCRETE	8" DOWEL JOINTED P.C. CONCRETE
BASE COURSE	3" SUPERPAVE TYPE S3 (PG 64-22 OK)	3" SUPERPAVE TYPE S3 (PG 64-22 OK)	3" SUPERPAVE TYPE S3 (PG 64-22 OK)

TYPICAL SECTION NO. 16: RAMP

NTS
CRL RAMP E8: STA. 78+53.10 TO STA. 83+00.00

VARIABLE WIDTH TABLE			
SECTION		WIDTH	STATION LIMITS
16	A	15'-0" TO 12'-0"	78+53.10 TO 80+72.35 (RAMP E8)
16	B	22'-0" TO 0'-0"	78+53.10 TO 80+72.35 (RAMP E8)

DESIGN		OKLAHOMA DEPARTMENT OF TRANSPORTATION
DRAWN		
CHECKED		
APPROVED		
SQUAD		
TYPICAL SECTION (9)		
COUNTY - TULSA	HIGHWAY US-75	STATE JOB NO. 33788(11) SHEET NO. 0011

P:\FDB\1650-TUL\CIV\40035-000T_EC2223A_US75\Design-Working\CIV\MicroStation\33788\1650\Sheets\33788\1650-Typical.dgn

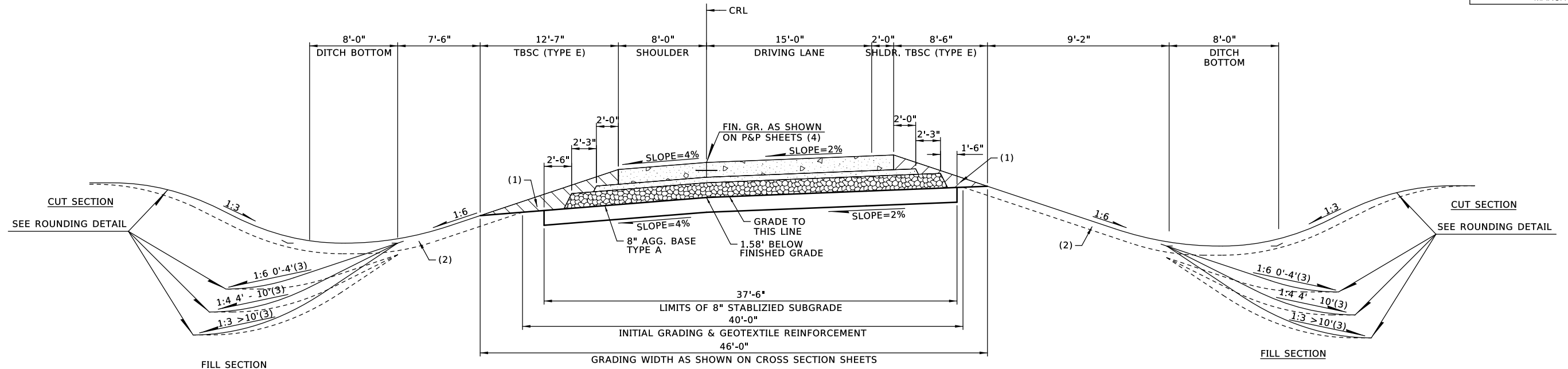

PAVEMENT REQUIREMENT			
PAVT. STRUCTURE	DRIVING LANES	PAVED INSIDE SHOULDER	PAVED OUTSIDE SHOULDER
SURFACE COURSE	8" DOWEL JOINTED P.C. CONCRETE	8" DOWEL JOINTED P.C. CONCRETE	8" DOWEL JOINTED P.C. CONCRETE
BASE COURSE	3" SUPERPAVE TYPE S3 (PG 64-22 OK)	3" SUPERPAVE TYPE S3 (PG 64-22 OK)	3" SUPERPAVE TYPE S3 (PG 64-22 OK)

TYPICAL SECTION NO. 17: RAMP
NTS
CRL RAMP Z: STA. 622+16.41 TO STA. 624+80.00

REFER TO SHEET 0003 FOR TYPICAL SECTION NOTES

PAVEMENT DESIGN HAS NOT BEEN COMPLETED. SECTION USED FOR COST ESTIMATING PURPOSES.

DESIGN		OKLAHOMA DEPARTMENT OF TRANSPORTATION
DRAWN		
CHECKED		
APPROVED		
SQUAD		
TYPICAL SECTION (10)		
COUNTY	TULSA	HIGHWAY US-75 STATE JOB NO. 33788(11) SHEET NO. 0012

3/4/2021

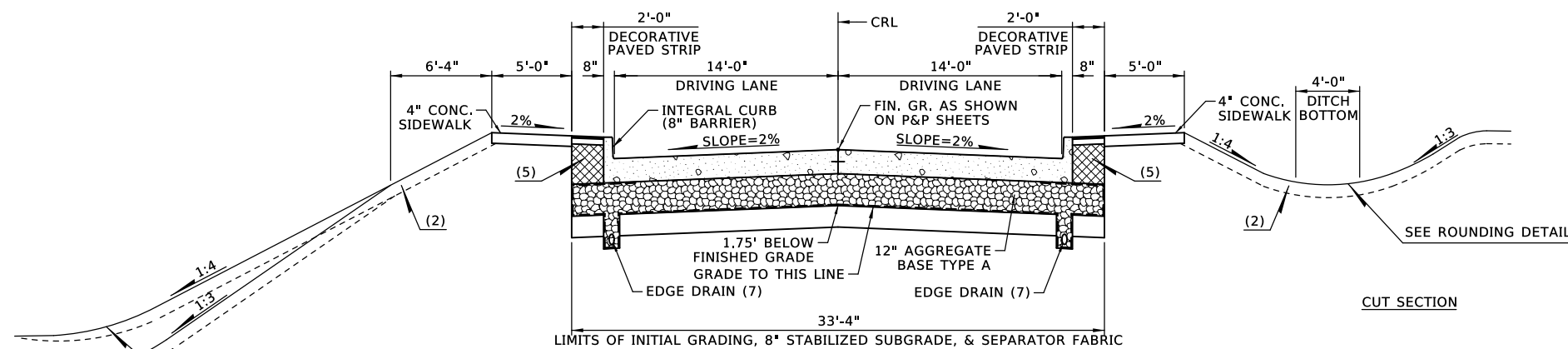

FILL SECTION

CUT SECTION

PAVEMENT REQUIREMENT	
PAVT. STRUCTURE	DRIVING LANES
SURFACE COURSE	9" DOWEL JOINTED P.C. CONCRETE

TYPICAL SECTION NO. 18: LOCAL ROAD

CRL 51st ST.: STA. 514+50.00 TO STA. 517+55.69 NTS

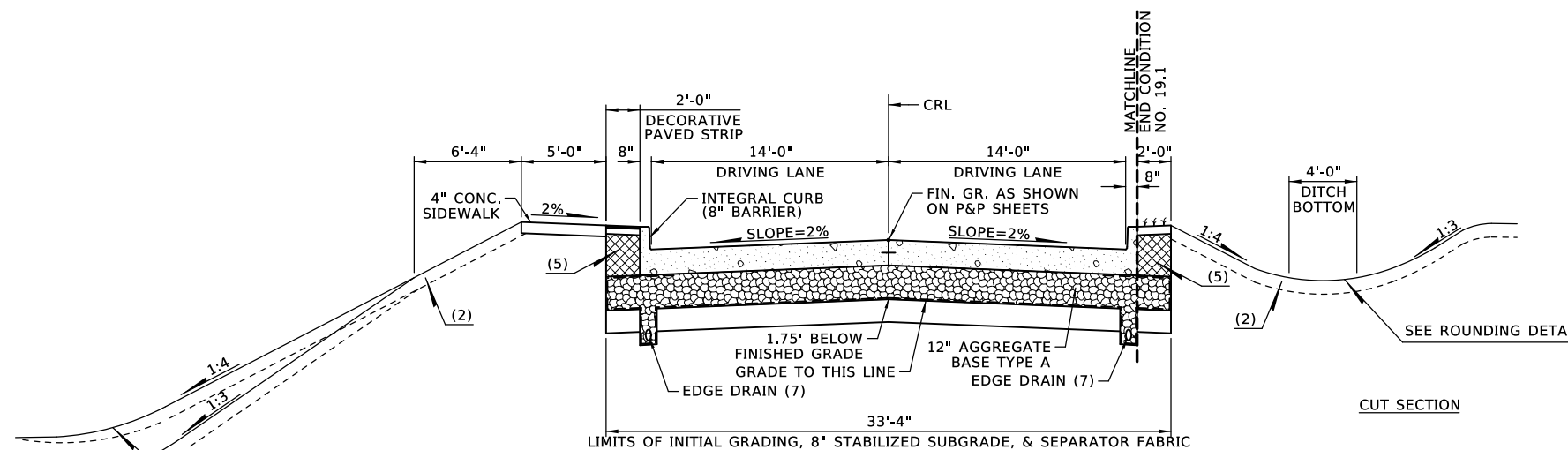

FILL SECTION

CUT SECTION

PAVEMENT REQUIREMENT	
PAVT. STRUCTURE	DRIVING LANES
SURFACE COURSE	9" DOWEL JOINTED P.C. CONCRETE

TYPICAL SECTION NO. 19: LOCAL ROAD

CRL 51st ST.: STA. 517+55.69 TO STA. 552+01.56 NTS

REFER TO SHEET 0003 FOR TYPICAL SECTION NOTES

PAVEMENT DESIGN HAS NOT BEEN COMPLETED. SECTION USED FOR COST ESTIMATING PURPOSES.

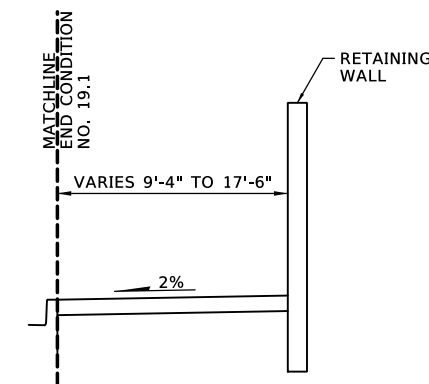

END CONDITION NO. 19.1: RETAINING WALL

NTS
 CRL 51st ST.: STA. 521+43.99 TO STA. 522+17.48 LT. (OPPOSITE HAND)
 CRL 51st ST.: STA. 523+07.03 TO STA. 523+75.40 RT.
 CRL 51st ST.: STA. 523+57.02 TO STA. 525+56.64 LT. (OPPOSITE HAND)
 CRL 51st ST.: STA. 525+45.68 TO STA. 526+05.68 RT.
 CRL 51st ST.: STA. 527+19.46 TO STA. 529+63.78 LT. (OPPOSITE HAND)
 CRL 51st ST.: STA. 531+37.00 TO STA. 532+76.99 RT.

DESIGN		OKLAHOMA DEPARTMENT OF TRANSPORTATION
DRAWN		
CHECKED		
APPROVED		
SQUAD		
TYPICAL SECTION (11)		
COUNTY - TULSA	HIGHWAY US-75	STATE JOB NO. 33788(11) SHEET NO. 0013

P:\FDB\1650-TUL\CIV\40035-000T_EC223A_US75_Design-Working\CIV\MicroStation\33788\1650\Sheets\33788\1-Typical.dgn

3/4/2021

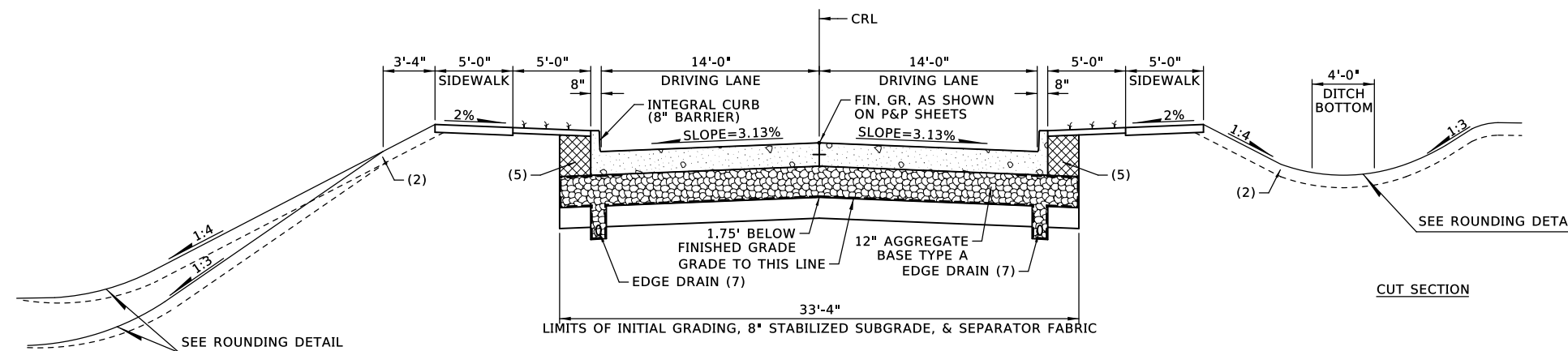

PAVEMENT REQUIREMENT	
PAVT. STRUCTURE	DRIVING LANES
SURFACE COURSE	9" DOWEL JOINTED P.C. CONCRETE

TYPICAL SECTION NO. 20: LOCAL ROAD
NTS

CRL 49th ST.: STA. 1+75.00 TO STA. 5+00.00
CRL 46th ST.: STA. 42+09.00 TO STA. 48+50.00

REFER TO SHEET 0003 FOR TYPICAL SECTION NOTES

PAVEMENT DESIGN HAS NOT BEEN COMPLETED. SECTION USED FOR COST ESTIMATING PURPOSES.

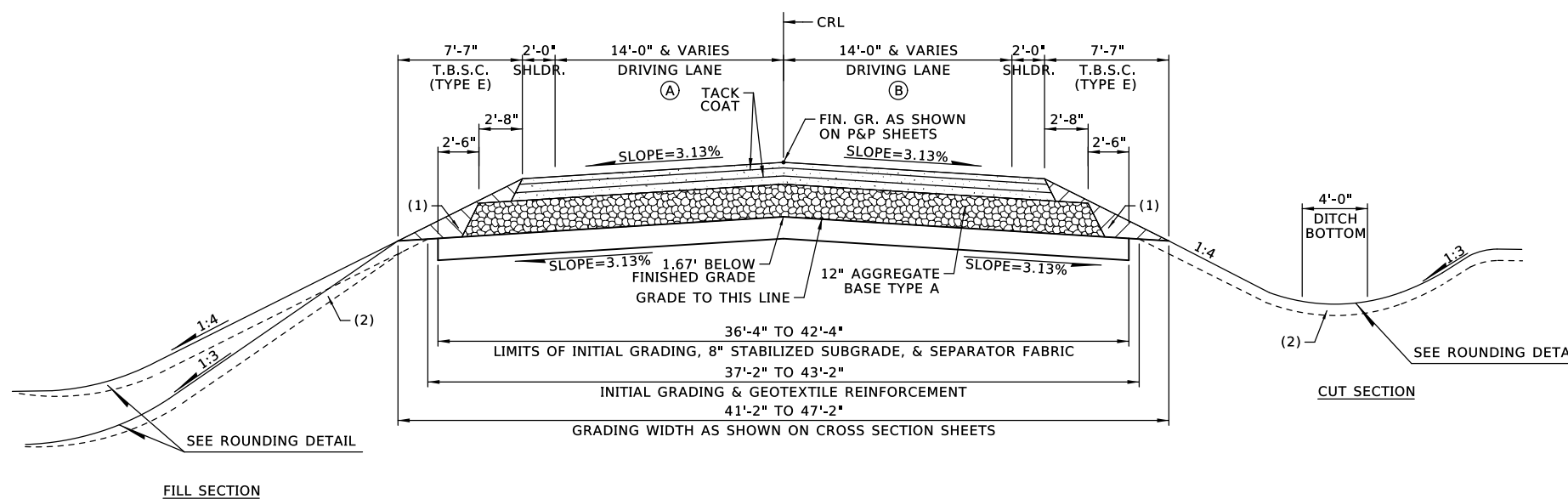

PAVEMENT REQUIREMENT		
PAVT. STRUCTURE	DRIVING LANES	PAVED OUTSIDE SHOULDER
SURFACE COURSE	2" SUPERPAVE S4 (PG 76-28 OK)	2" SUPERPAVE S4 (PG 76-28 OK)
BASE COURSE	3" SUPERPAVE S3 (PG 76-28 OK)	3" SUPERPAVE S3 (PG 76-28 OK)
	3" SUPERPAVE S3 (PG 76-28 OK)	3" SUPERPAVE S3 (PG 76-28 OK)

TYPICAL SECTION NO. 21: LOCAL ROAD
NTS

CRL 49th ST.: STA. 1+25.00 TO STA. 1+75.00
CRL 49th ST.: STA. 5+00.00 TO STA. 5+75.00

VARIABLE WIDTH TABLE			
SECTION		WIDTH	STATION LIMITS
21	A	11'-0" TO 14'-0"	1+25.00 TO 1+75.00
21	A	14'-0" TO 11'-0"	5+00.00 TO 5+75.00
21	B	11'-0" TO 14'-0"	1+25.00 TO 1+75.00
21	B	14'-0" TO 11'-0"	5+00.00 TO 5+75.00

DESIGN		OKLAHOMA DEPARTMENT OF TRANSPORTATION
DRAWN		
CHECKED		
APPROVED		
SQUAD		
TYPICAL SECTION (12)		
COUNTY	TULSA	HIGHWAY US-75 STATE JOB NO. 33788(11) SHEET NO. 0014

P:\FDB\1650-TUL\CIV\40035-000T_EC2123A_US75_Design-Working\CIV\MicroStation\33788\WP5\Sheets\33788\Typical_12.dgn

3/4/2021

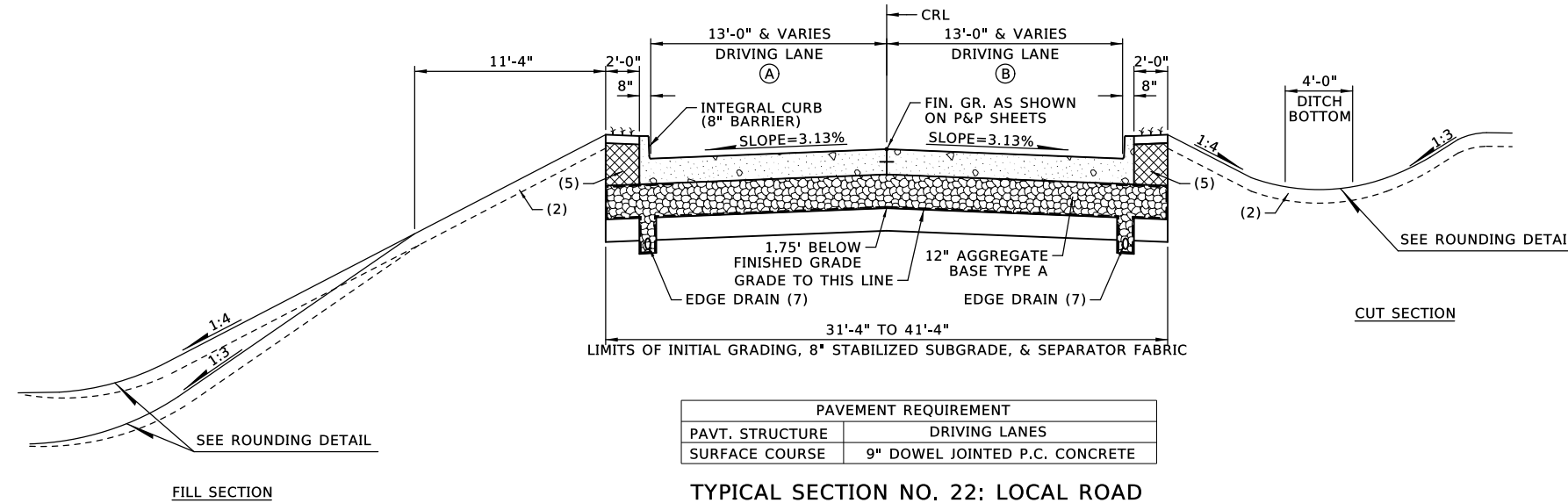

TYPICAL SECTION NO. 22: LOCAL ROAD

CRL OLYMPIA AVE.: STA. 10+39.00 TO STA. 13+56.00
 CRL LAWTON AVE.: STA. 0+44.00 TO STA. 1+16.00
 CRL JACKSON AVE.: STA. 0+40.00 TO STA. 1+12.00

VARIABLE WIDTH TABLE			
SECTION		WIDTH	STATION LIMITS
22	A	18'-0"	0+39.00 TO 1+12.00 (JACKSON AVE.)
22	B	18'-0"	0+39.00 TO 1+12.00 (JACKSON AVE.)

REFER TO SHEET 0003 FOR TYPICAL SECTION NOTES

PAVEMENT DESIGN HAS NOT BEEN COMPLETED. SECTION USED FOR COST ESTIMATING PURPOSES.

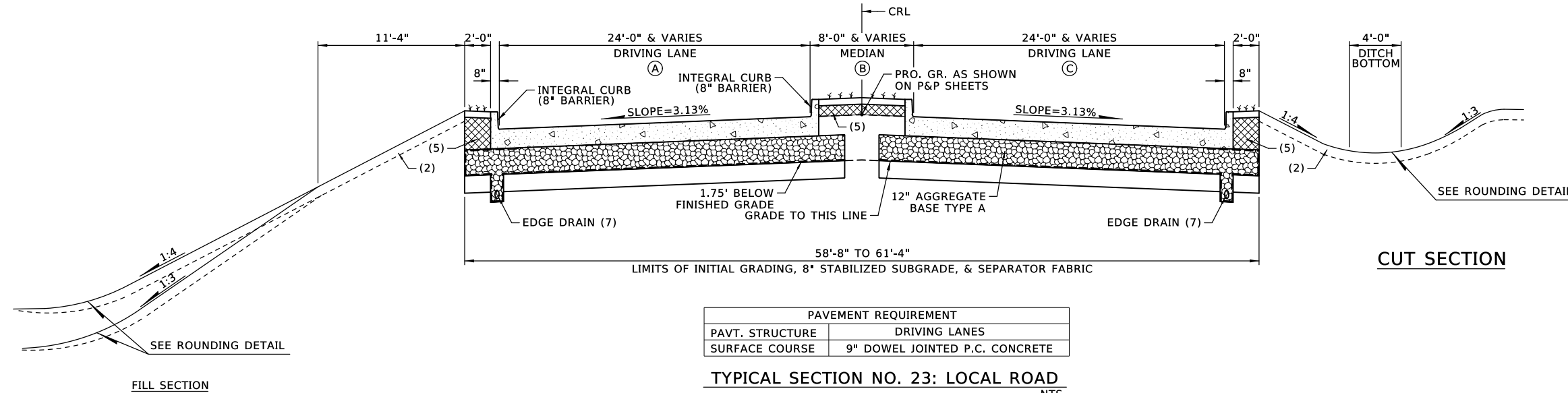

TYPICAL SECTION NO. 23: LOCAL ROAD

CRL INDIAN AVE.: STA. 0+56.99 TO STA. 1+65.00

VARIABLE WIDTH TABLE			
SECTION		WIDTH	STATION LIMITS
23	A	28'-0"	0+56.99 TO 0+61.00 (INDIAN AVE.)
23	A	28'-0" TO 24'-0"	0+61.00 TO 0+65.00 (INDIAN AVE.)
23	B	0'-0"	0+56.99 TO 0+61.00 (INDIAN AVE.)
23	B	0'-0" TO 8'-0"	0+61.00 TO 0+65.00 (INDIAN AVE.)
23	C	28'-0"	0+56.99 TO 0+61.00 (INDIAN AVE.)
23	C	28'-0" TO 24'-0"	0+61.00 TO 0+65.00 (INDIAN AVE.)

DESIGN		OKLAHOMA DEPARTMENT OF TRANSPORTATION
DRAWN		
CHECKED		
APPROVED		
SQUAD		
TYPICAL SECTION (13)		
COUNTY	TULSA	HIGHWAY US-75 STATE JOB NO. 33788(11) SHEET NO. 0015

P:\FDB\1650-TUL\CIV\40035-000T_EC223A_US75\Design-Working\CIV\MicroStation\33788\1650\Sheets\33788\1-Typical.dgn

3/4/2021

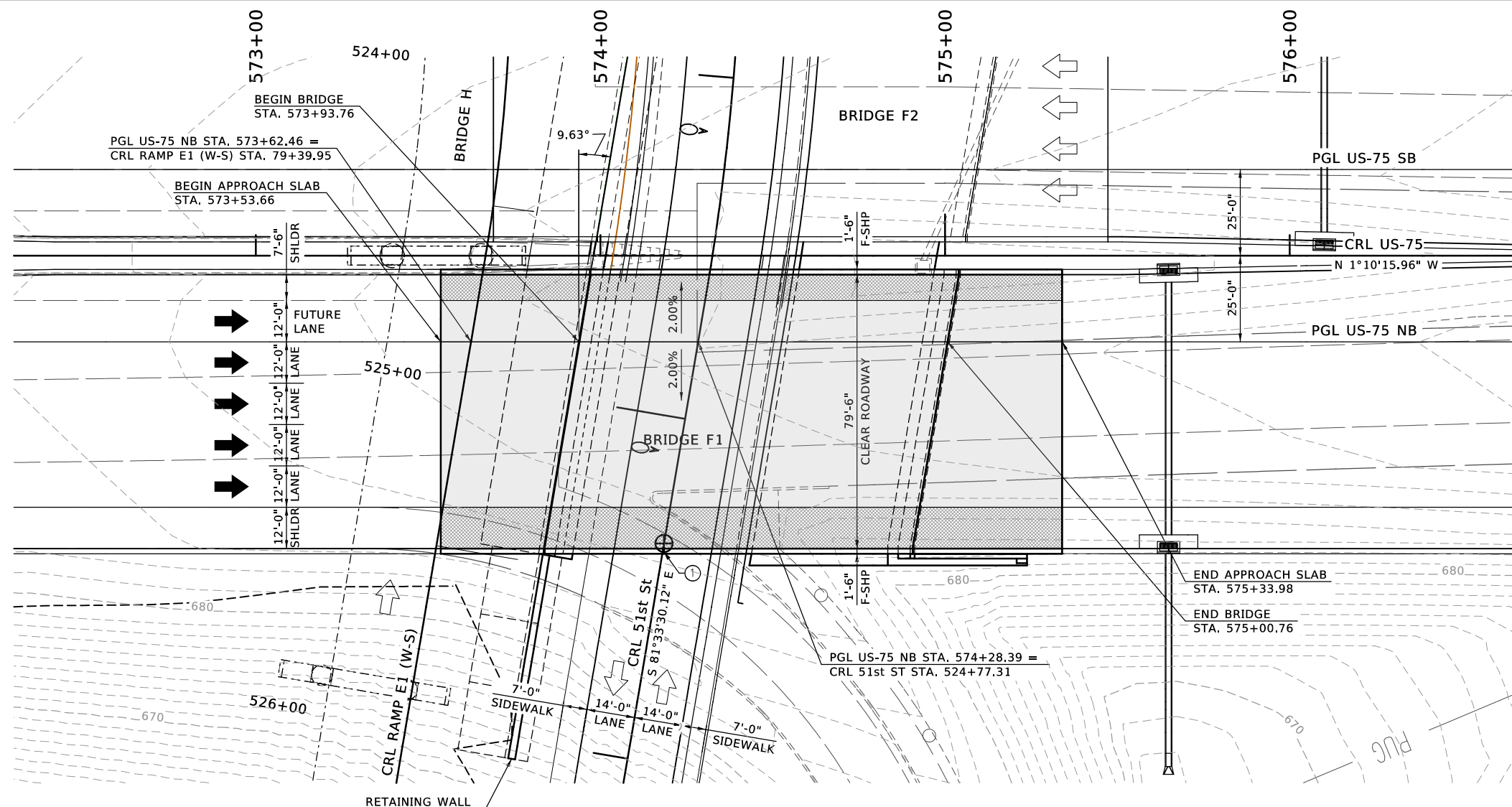

PLAN

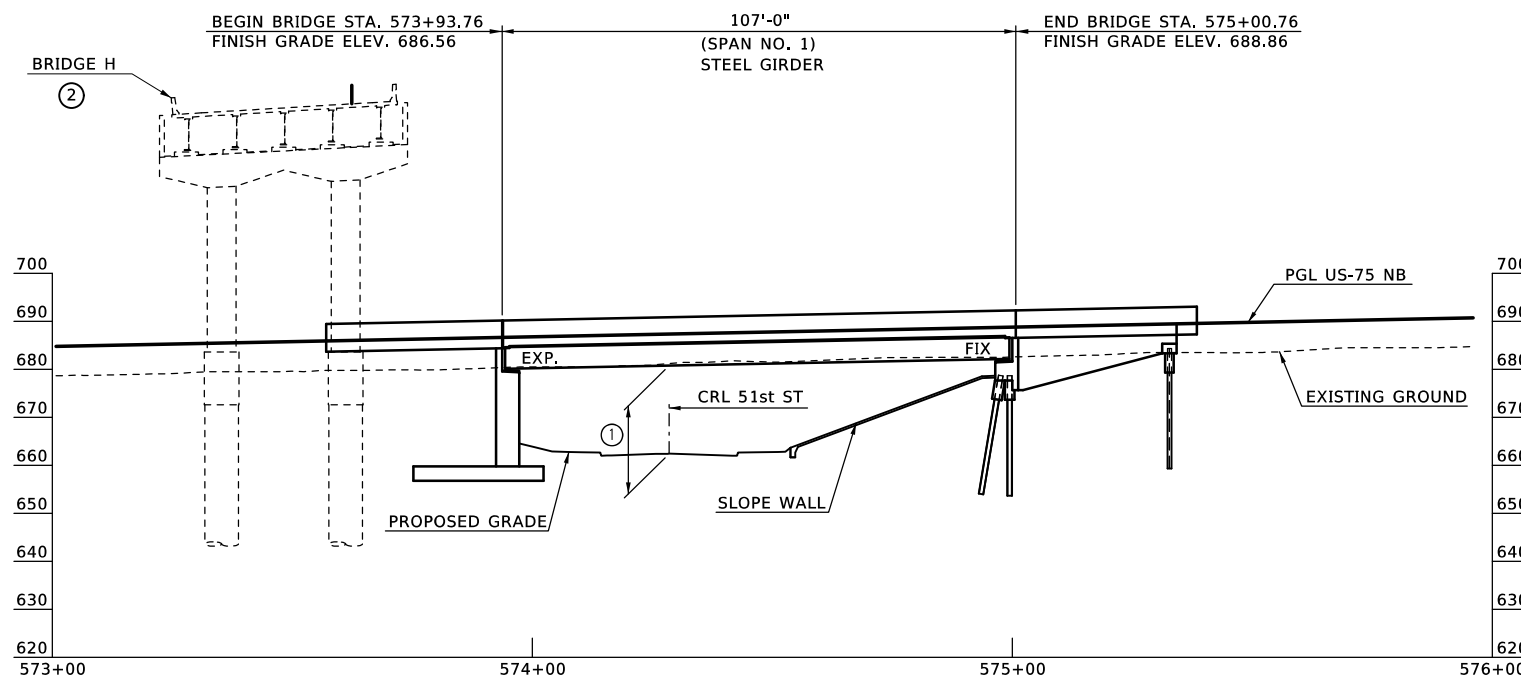

ELEVATION

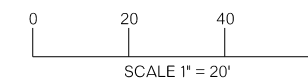

BENCHMARK 109A
 CUT X
 STA. 268+02.61, 63.73' LT CLS US-75
 STA. 576+80.06, 63.89' LT CRL US-75
 N 403077.23, E 2557343.09, EL. 684.871

BENCHMARK 109B
 CUT BOX
 STA. 262+91.38, 0.32' RT CLS US-75
 STA. 571+68.83, 0.16' RT CRL US-75
 N 402567.42, E 2557417.57, EL. 675.341

- ① PROPOSED MIN. VERTICAL CLEARANCE 17'-0"
 PGL US-75 NB STA. 574+18.48
 OFFSET 58'-6" RT.
- ② CONSTRUCTED IN WORK PACKAGE JP 33788(08).

NOTES:
 FOR DESIGN DATA, VERTICAL PROFILE DATA, AND
 FOUNDATION DATA SEE SHEET NO. B002.

BRIDGE F1, I-44 & US-75 US-75 NB OVER W. 51st ST.	TULSA COUNTY	Design	KSJ	4/20
GENERAL PLAN AND ELEVATION (SHEET 1 OF 2) CONSTRUCT 107' LONG STEEL GIRDER SPAN, 10 DEG. SKEW LF, 79'-6" CLEAR ROADWAY W/ F-SHP PARAPET, C.L. STA. 574+47.26 US-75		Detail	TBG	6/20
		Check	SOT	8/20
STATE OF OKLAHOMA	DEPARTMENT OF TRANSPORTATION	JOB PIECE NO. 33788(11)	SHEET NO. B001	

P:\FDB\650-TUL\CIV\400315_0DOT_EC2123A_US75\Design-Working\STRC\Microstation\33788\WP5\Sheets\Bridges\FN\33788\SI\GENERAL PLAN AND ELEVATION 01.dgn

DESIGN DATA

LOAD AND RESISTANCE FACTOR DESIGN

CLASS AA CONCRETE	f'c = 4,000 PSI
CLASS A CONCRETE	f'c = 3,000 PSI
REINFORCING STEEL (GRADE 60)	Fy = 60,000 PSI
STRUCTURAL STEEL M270 (GRADE 50W)	Fy = 50,000 PSI
STAINLESS STEEL A240 (TYPE 316);	Fy = 30,000 PSI
STAINLESS STEEL A320, CLASS 2, (GRADE B8M);	Fy = 58,000 PSI

LOADING: HL-93 OR OKLAHOMA OVERLOAD TRUCK
 20 PSF FUTURE WEARING SURFACE
 5 PSF STAY IN PLACE FORMS

DESIGN: AASHTO LRFD BRIDGE DESIGN SPECIFICATIONS 8TH EDITION

ANSI/AASHTO/AWS D1.5 BRIDGE WELDING CODE
 ANSI/AWS D1.6 STRUCTURAL WELDING CODE - STAINLESS STEEL

LRFR OPERATING RATING = XXX

INDEX OF SHEETS

B001 - B002 B003	GENERAL PLAN AND ELEVATION SUPERSTRUCTURE DETAILS
---------------------	--

FOUNDATION DATA

ABUTMENT #2 (HP XX X XX PILING)

FACTORED PILE REACTION (TONS/PILE) = XX.X

ALL ABUTMENT PILING SHALL BE DRIVEN THROUGH THE COMPACTED FILL. PILING SHALL BE DRIVEN TO POINT BEARING ON SOLID FOUNDATION MATERIAL AT THE APPROXIMATE ELEVATION SHOWN ON THE PLANS.

IF THE AXIAL LOAD RESISTANCE IS NOT OBTAINED AT THIS ELEVATION, DRIVING SHALL CONTINUE UNTIL THE AXIAL LOAD RESISTANCE IS OBTAINED. THE LENGTH OF STEEL PILING SHOWN ON THE PLANS IS FOR ESTIMATING PURPOSES ONLY.

ABUTMENT #1 (XX" DIAMETER DRILLED SHAFTS)

FACTORED REACTION (TONS/SHAFT) = XX.X

NOMINAL UNIT BEARING RESISTANCE (TSF) = XX.X
 BEARING RESISTANCE FACTOR = XX.X
 FACTORED BEARING RESISTANCE (TON/SHAFT) = XX.X

NOMINAL UNIT FRICTION RESISTANCE (TSF) = XX.X
 FRICTION RESISTANCE FACTOR = XX.X
 FACTORED FRICTION RESISTANCE (TON/SHAFT) = XX.X

FRICTION DEPTH OF ROCK NEGLECTED (FT) = XX.X
 MINIMUM DEPTH INTO FOUNDATION MATERIAL (FT) = XX.X

TOTAL FACTORED RESISTANCE (TONS/SHAFT) = XX.X

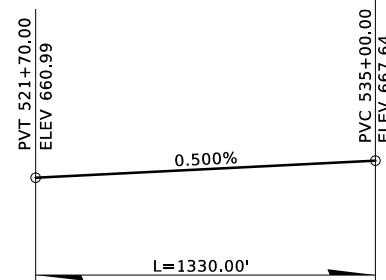

VERTICAL PROFILE DATA - 51st STREET

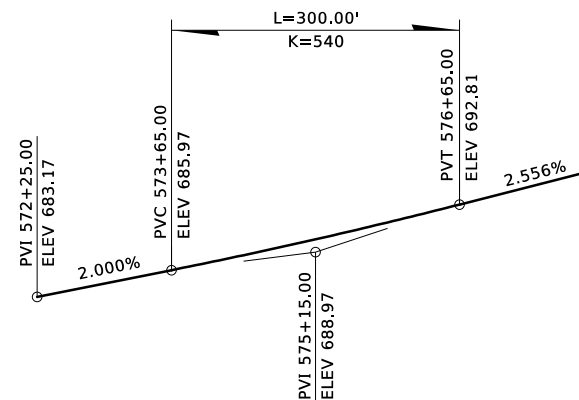

VERTICAL PROFILE DATA - CRL US-75

ITEMIZED QUANTITIES

ITEM	UNIT	ABUTMENT	PIER	SUPER-STRUCTURE	APPROACH SLAB	SLOPEWALL	TOTAL

BRIDGE F1, I-44 & US-75 US-75 NB OVER W. 51st ST. GENERAL PLAN AND ELEVATION (SHEET 2 OF 2) CONSTRUCT 107' LONG STEEL GIRDER SPAN, 10 DEG. SKEW LF, 79'-6" CLEAR ROADWAY W/ F-SHP PARAPET, C.L. STA. 574+47.26 US-75	TULSA COUNTY	<table border="1" style="width: 100%; border-collapse: collapse; text-align: center;"> <tr> <td style="font-size: small;">Design</td> <td style="font-size: small;">KSJ</td> <td style="font-size: small;">4/20</td> </tr> <tr> <td style="font-size: small;">Detail</td> <td style="font-size: small;">TBG</td> <td style="font-size: small;">6/20</td> </tr> <tr> <td style="font-size: small;">Check</td> <td style="font-size: small;">SOT</td> <td style="font-size: small;">8/20</td> </tr> </table>	Design	KSJ	4/20	Detail	TBG	6/20	Check	SOT	8/20
Design	KSJ	4/20									
Detail	TBG	6/20									
Check	SOT	8/20									
STATE OF OKLAHOMA	DEPARTMENT OF TRANSPORTATION	SHEET NO. B002									
JOB PIECE NO. 33788(11)		SHEET NO. B002									

3/4/2021

P:\FDB\650-TUL\CIV\400315_ODOT_EC2123A_US75\Design-Working\STRC\Microstation\3378811\WP5\Sheets\Bridges\3378811\TYPICAL_SECTION_01.dgn

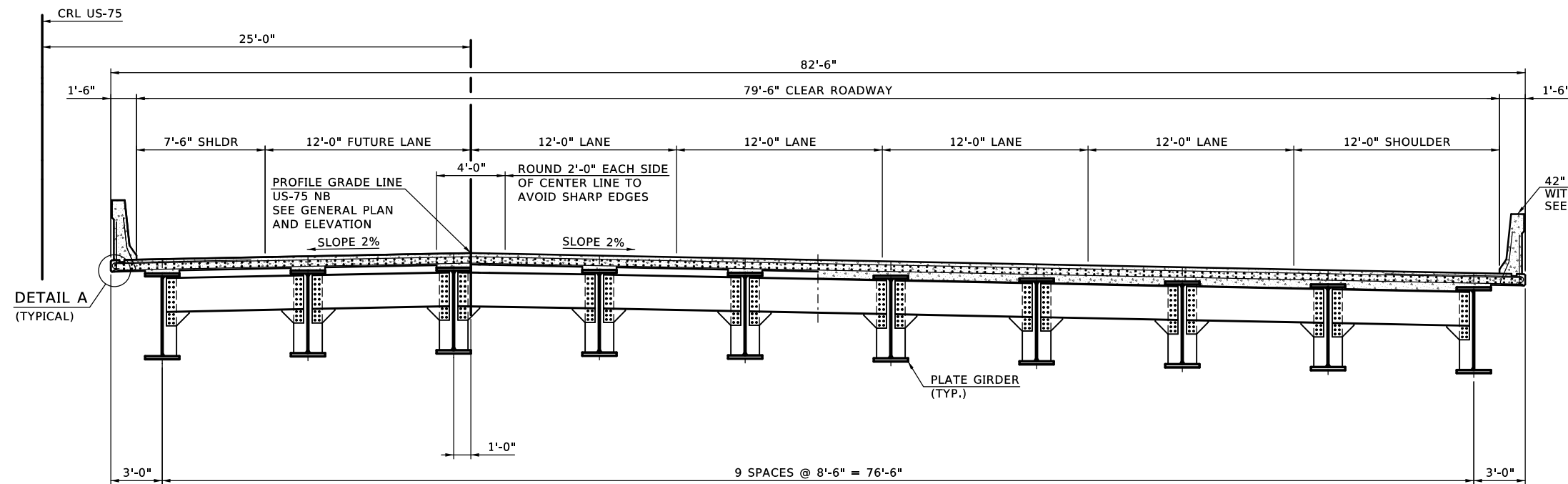

HALF SECTION AT INTERMEDIATE DIAPHRAGM

TYPICAL SECTION

HALF SECTION AT END DIAPHRAGM

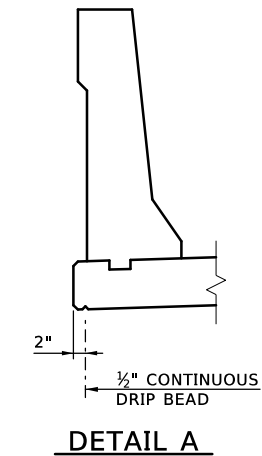

DETAIL A

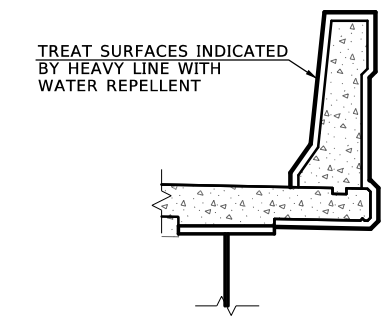

WATER REPELLENT TREATMENT DETAIL

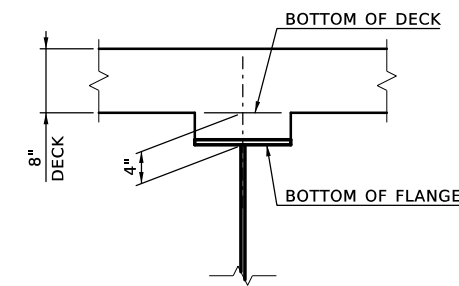

BEAM HAUNCH DETAIL (PLATE GIRDER)

NOTE:
 PLAN QUANTITIES FOR CLASS AA CONCRETE INCLUDE GIRDER HAUNCHES. THE HAUNCH HEIGHT SHOWN IS THE THEORETICAL HAUNCH HEIGHT AT THE CENTERLINE BEARING ONLY, MEASURED FROM THE BOTTOM OF THE DECK SLAB TO THE TOP OF THE WEB, AND VARIES ACROSS THE SPAN. DETERMINE THE ACTUAL HAUNCH HEIGHT (ACCOUNTING FOR BEAM CAMBER, DEAD LOAD DEFLECTION AND ROADWAY GRADE) AFTER ERECTION OF THE BEAMS AND SUBMIT TO THE ENGINEER FOR APPROVAL. THE ENGINEER WILL NOT MEASURE DIFFERENCES BETWEEN THE THEORETICAL AND THE ACTUAL HAUNCH HEIGHTS FOR PAYMENT.

BRIDGE F1, I-44 & US-75 US-75 NB OVER W. 51st ST.		TULSA COUNTY		Design	KSJ	4/20
SUPERSTRUCTURE DETAILS				Detail	TBG	6/20
				Check	SOT	8/20
STATE OF OKLAHOMA		DEPARTMENT OF TRANSPORTATION		JOB PIECE NO. 33788(11)		
						SHEET NO. B003



R/W UTILITY MEETING

MARCH 2021

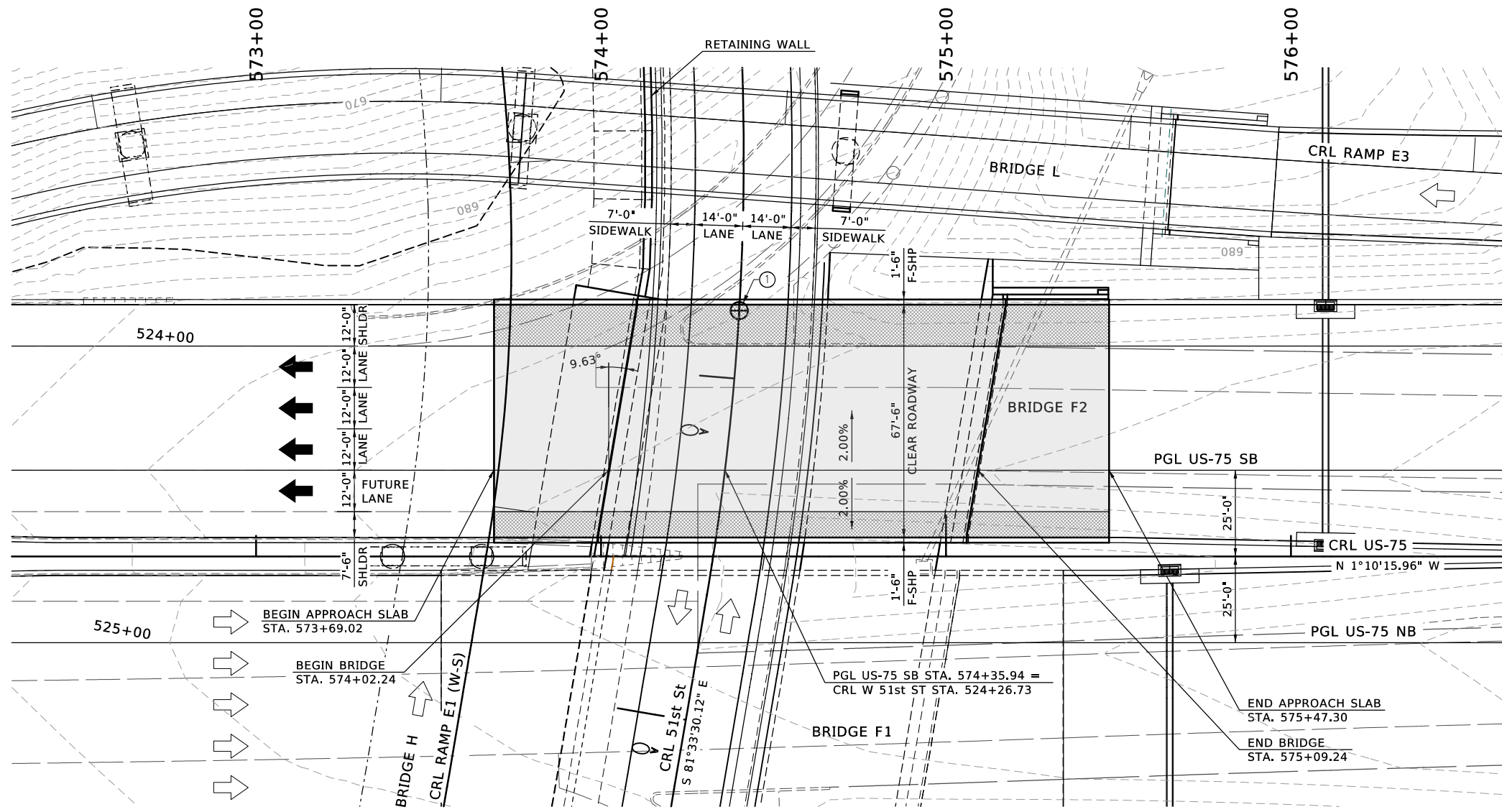
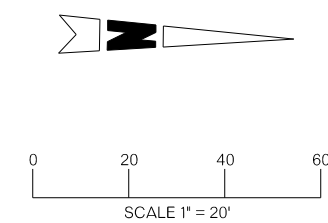

PLAN

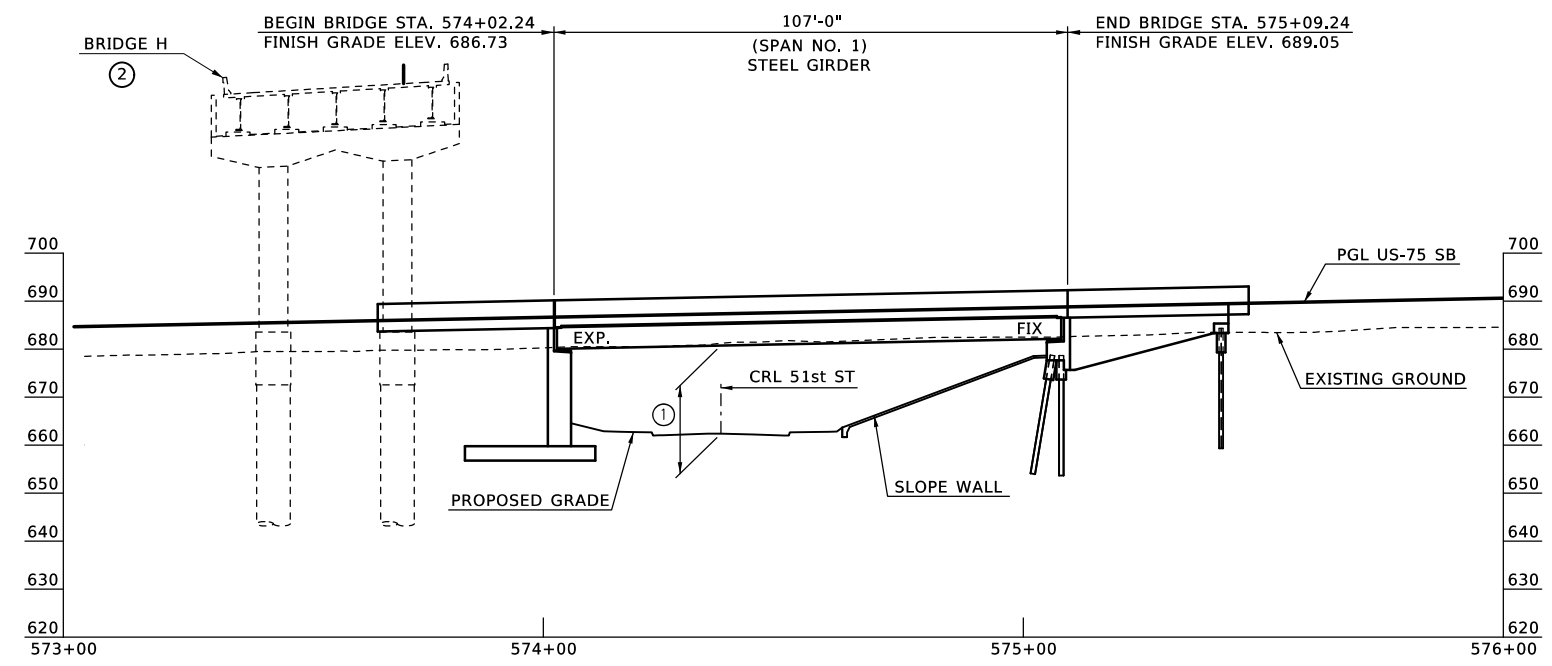

ELEVATION

BENCHMARK 109A
 CUT X
 STA. 268+02.61, 63.73' LT CLS US-75
 STA. 576+80.06, 63.89' LT CRL US-75
 N 403077.23, E 2557343.09, EL. 684.871

BENCHMARK 109B
 CUT BOX
 STA. 262+91.38, 0.32' RT CLS US-75
 STA. 571+68.83, 0.16' RT CRL US-75
 N 402567.42, E 2557417.57, EL. 675.341

- ① PROPOSED MIN. VERTICAL CLEARANCE 18'-6"
 PGL US 75 SB STA. 574+40.07
 OFFSET 46'-3" LT.
- ② CONSTRUCTED IN WORK PACKAGE JP 33788(08).

NOTES:
 FOR DESIGN DATA, VERTICAL PROFILE DATA, AND
 FOUNDATION DATA SEE SHEET NO. B005.

BRIDGE F2, I-44 & US-75		TULSA COUNTY		Design	KSJ	4/20
US-75 SB OVER W. 51st ST.				Detail	TBG	6/20
GENERAL PLAN AND ELEVATION				Check	SOT	8/20
(SHEET 1 OF 2)						
CONSTRUCT 107' LONG STEEL GIRDER SPAN, 10 DEG. SKEW LF, 67'-6" CLEAR ROADWAY W/ F-SHP PARAPET, C.L. STA. 574+55.74 US-75						
STATE OF OKLAHOMA		DEPARTMENT OF TRANSPORTATION			JOB PIECE NO. 33788(11)	
					SHEET NO. B004	

3/4/2021
 P:\FDB\650-TUL\CIV\400315_0DOT_EC2123A_US75\Design-Work\King\STRC\Microstation\33788\WP5\Sheets\Bridges\F2\33788\I-44 & US-75 SB OVER W. 51st ST.dgn

DESIGN DATA
LOAD AND RESISTANCE FACTOR DESIGN

CLASS AA CONCRETE f'c = 4,000 PSI
CLASS A CONCRETE f'c = 3,000 PSI
REINFORCING STEEL (GRADE 60) Fy = 60,000 PSI
STRUCTURAL STEEL M270 (GRADE 50W) Fy = 50,000 PSI
STAINLESS STEEL A240 (TYPE 316); Fy = 30,000 PSI
STAINLESS STEEL A320, CLASS 2, (GRADE B8M); Fy = 58,000 PSI

LOADING: HL-93 OR OKLAHOMA OVERLOAD TRUCK
20 PSF FUTURE WEARING SURFACE
5 PSF STAY IN PLACE FORMS

DESIGN: AASHTO LRFD BRIDGE DESIGN SPECIFICATIONS 8TH EDITION

ANSI/AASHTO/AWS D1.5 BRIDGE WELDING CODE
ANSI/AWS D1.6 STRUCTURAL WELDING CODE - STAINLESS STEEL

LRFR OPERATING RATING = XXX

FOUNDATION DATA
ABUTMENT #2 (HP XX X XX PILING)

FACTORED PILE REACTION (TONS/PILE) = XX.X

ALL ABUTMENT PILING SHALL BE DRIVEN THROUGH THE COMPACTED FILL. PILING SHALL BE DRIVEN TO POINT BEARING ON SOLID FOUNDATION MATERIAL AT THE APPROXIMATE ELEVATION SHOWN ON THE PLANS.
IF THE AXIAL LOAD RESISTANCE IS NOT OBTAINED AT THIS ELEVATION, DRIVING SHALL CONTINUE UNTIL THE AXIAL LOAD RESISTANCE IS OBTAINED. THE LENGTH OF STEEL PILING SHOWN ON THE PLANS IS FOR ESTIMATING PURPOSES ONLY.

ABUTMENT #1 (XX" DIAMETER DRILLED SHAFTS)

FACTORED REACTION (TONS/SHAFT) = XX.X
NOMINAL UNIT BEARING RESISTANCE (TSF) = XX.X
BEARING RESISTANCE FACTOR = XX.X
FACTORED BEARING RESISTANCE (TON/SHAFT) = XX.X
NOMINAL UNIT FRICTION RESISTANCE (TSF) = XX.X
FRICTION RESISTANCE FACTOR = XX.X
FACTORED FRICTION RESISTANCE (TON/SHAFT) = XX.X
FRICTION DEPTH OF ROCK NEGLECTED (FT) = XX.X
MINIMUM DEPTH INTO FOUNDATION MATERIAL (FT) = XX.X
TOTAL FACTORED RESISTANCE (TONS/SHAFT) = XX.X

INDEX OF SHEETS

B004 - B005 GENERAL PLAN AND ELEVATION
B006 SUPERSTRUCTURE DETAILS

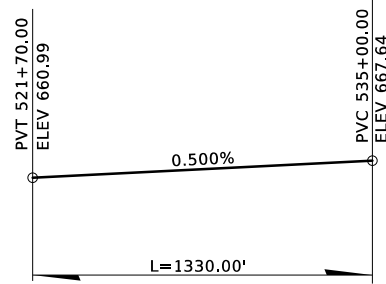

VERTICAL PROFILE DATA - 51st STREET

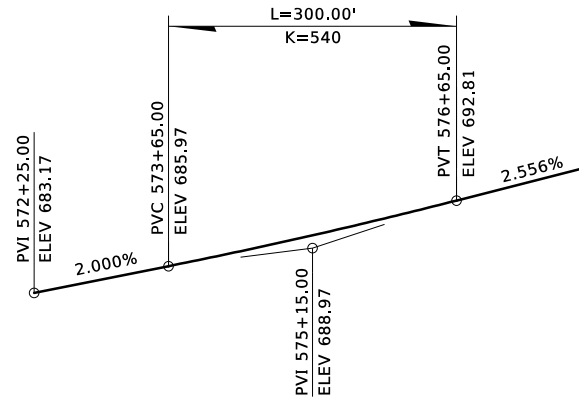

VERTICAL PROFILE DATA - CRL US-75

ITEMIZED QUANTITIES							
ITEM	UNIT	ABUTMENT	PIER	SUPER-STRUCTURE	APPROACH SLAB	SLOPEWALL	TOTAL

BRIDGE F2, I-44 & US-75 TULSA COUNTY
US-75 SB OVER W. 51st ST.
GENERAL PLAN AND ELEVATION (SHEET 2 OF 2)
CONSTRUCT 107' LONG STEEL GIRDER SPAN,
10 DEG. SKEW LF, 67'-6" CLEAR ROADWAY
W/F-SHP PARAPET, C.L. STA. 574+55.74 US-75

Design	KSJ	4/20
Detail	TBG	6/20
Check	SOT	8/20

STATE OF OKLAHOMA DEPARTMENT OF TRANSPORTATION
JOB PIECE NO. 33788(11) SHEET NO. B005

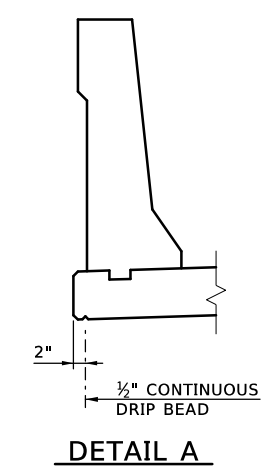
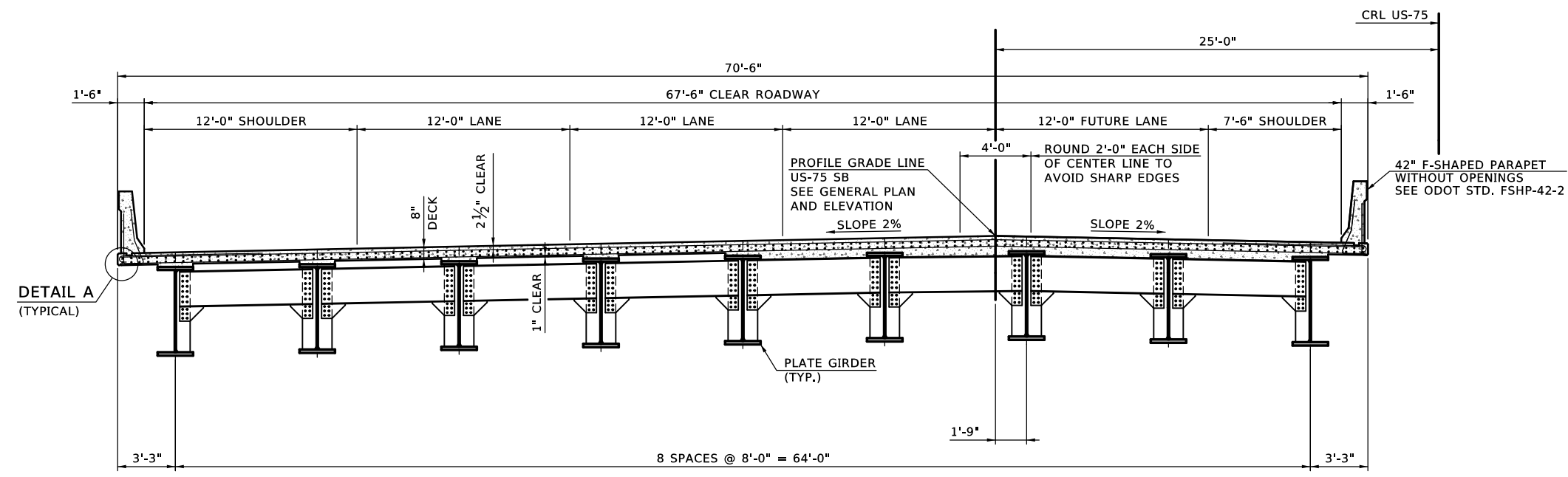

HALF SECTION AT INTERMEDIATE DIAPHRAGM

TYPICAL SECTION

HALF SECTION AT END DIAPHRAGM

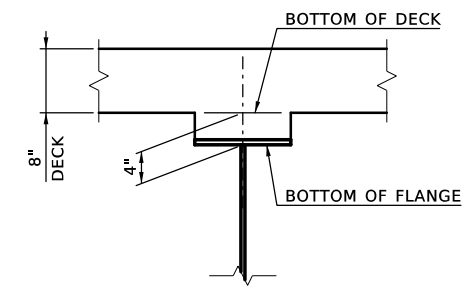
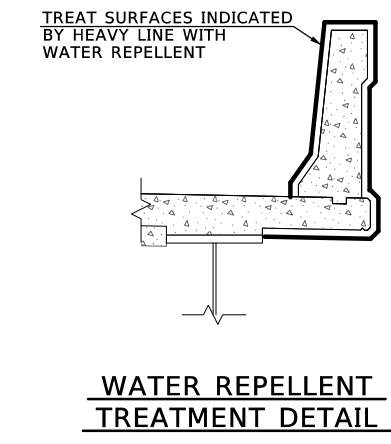

BEAM HAUNCH DETAIL (PLATE GIRDER)

NOTE:
 PLAN QUANTITIES FOR CLASS AA CONCRETE INCLUDE GIRDER HAUNCHES. THE HAUNCH HEIGHT SHOWN IS THE THEORETICAL HAUNCH HEIGHT AT THE CENTERLINE BEARING ONLY, MEASURED FROM THE BOTTOM OF THE DECK SLAB TO THE TOP OF THE WEB, AND VARIES ACROSS THE SPAN. DETERMINE THE ACTUAL HAUNCH HEIGHT (ACCOUNTING FOR BEAM CAMBER, DEAD LOAD DEFLECTION AND ROADWAY GRADE) AFTER ERECTION OF THE BEAMS AND SUBMIT TO THE ENGINEER FOR APPROVAL. THE ENGINEER WILL NOT MEASURE DIFFERENCES BETWEEN THE THEORETICAL AND THE ACTUAL HAUNCH HEIGHTS FOR PAYMENT.

BRIDGE F2, I-44 & US-75		TULSA COUNTY		Design	KSJ	4/20
US-75 SB OVER W. 51st ST.				Detail	TBG	6/20
				Check	SOT	8/20
SUPERSTRUCTURE DETAILS						
STATE OF OKLAHOMA		DEPARTMENT OF TRANSPORTATION			JOB PIECE NO. 33788(11)	
					SHEET NO. B006	

P:\FDB\650-TUL\CIV\400315_ODOT_EC2123A_US75\Design-Working\STRC\Microstation\33788\WP5\Sheets\Bridg F2\33788\I S2 TYPICAL SECTION 01.dgn 3/4/2021



BENCHMARK 104
 CUT X
 STA. 296+23.28, 74.83' LT CLS US-75
 STA. 605+00.76, 75.15' LT CRL US-75
 N 405877.59, E 2557190.54, EL. 700.966

BENCHMARK 105
 CUT X
 STA. 290+00.39, 89.22' LT CLS US-75
 STA. 598+77.83, 89.44' LT CRL US-75
 N 405267.83, E 2557261.24, EL. 706.515

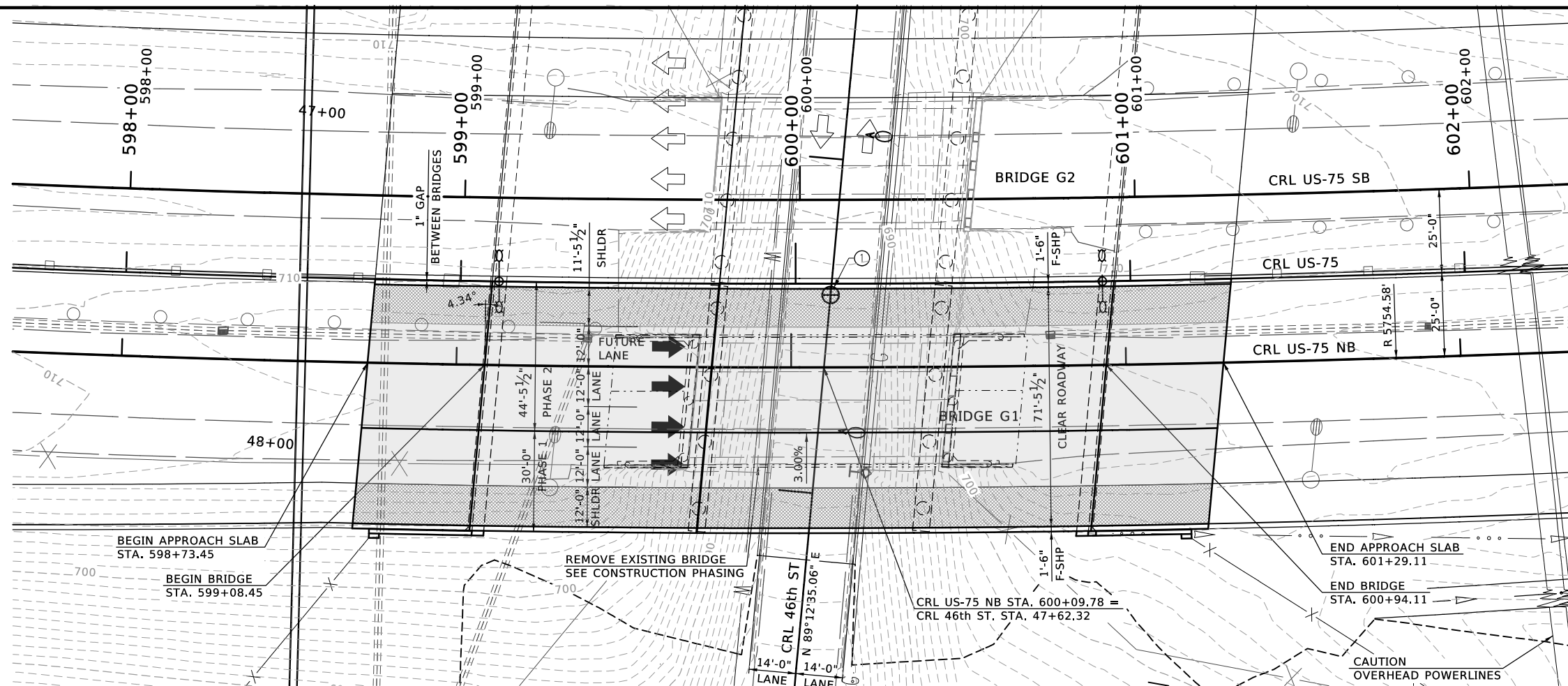

PLAN

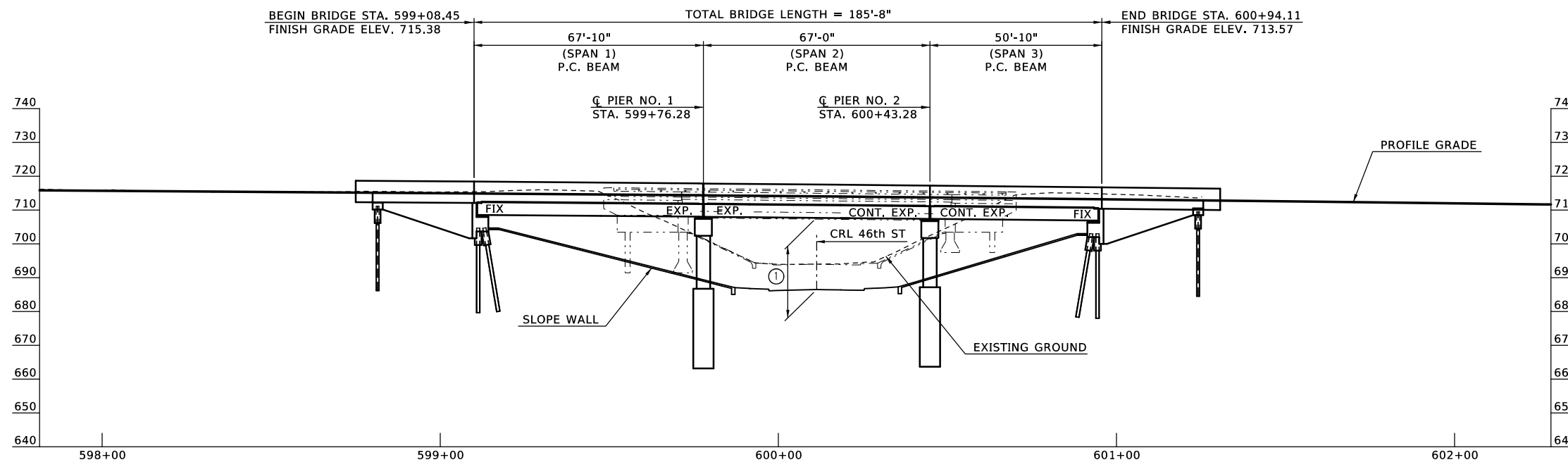

ELEVATION

① PROPOSED MIN. VERTICAL CLEARANCE 21'-10"
 CRL US-75 NB STA. 600+11.81
 OFFSET 21'-7" LT.

NOTES:
 FOR DESIGN DATA, VERTICAL PROFILE DATA,
 AND FOUNDATION DATA SEE SHEET NO. B008.

BRIDGE G1, I-44 & US-75 US-75 NB OVER W. 46th ST.	TULSA COUNTY	Design	KSJ	4/20
GENERAL PLAN AND ELEVATION (SHEET 1 OF 2)		Detail	TBG	6/20
		Check	SOT	8/20
CONSTRUCT 67'-67'-50' TYPE III P.C. BEAM SPANS, 5 DEG. SKEW LF, 71'-5" CLEAR ROADWAY W/F-SHP PARAPETS, CL. STA. 600+01.28 US-75				
STATE OF OKLAHOMA	DEPARTMENT OF TRANSPORTATION			

REMOVE EXISTING BRIDGE @ STA. 600+09.78 US-75
 80' SINGLE SPAN STEEL GIRDER, 38' CLEAR ROADWAY

DESIGN DATA LOAD AND RESISTANCE FACTOR DESIGN

CLASS AA CONCRETE	f'c = 4,000 PSI
CLASS A CONCRETE	f'c = 3,000 PSI
REINFORCING STEEL (GRADE 60)	Fy = 60,000 PSI
STRUCTURAL STEEL M270 (GRADE 50W)	Fy = 50,000 PSI
STAINLESS STEEL A240 (TYPE 316);	Fy = 30,000 PSI
STAINLESS STEEL A320, CLASS 2, (GRADE B8M);	Fy = 58,000 PSI

LOADING: HL-93 OR OKLAHOMA OVERLOAD TRUCK
 20 PSF FUTURE WEARING SURFACE
 5 PSF STAY IN PLACE FORMS

DESIGN: AASHTO LRFD BRIDGE DESIGN SPECIFICATIONS 8TH EDITION

ANSI/AASHTO/AWS D1.5 BRIDGE WELDING CODE
 ANSI/AWS D1.6 STRUCTURAL WELDING CODE - STAINLESS STEEL

LRFR OPERATING RATING = XXX

FOUNDATION DATA ABUTMENTS (HP XX X XX PILING)

FACTORED PILE REACTION (TONS/PILE) = XX.X

ALL ABUTMENT PILING SHALL BE DRIVEN THROUGH THE COMPACTED FILL. PILING SHALL BE DRIVEN TO POINT BEARING ON SOLID FOUNDATION MATERIAL AT THE APPROXIMATE ELEVATION SHOWN ON THE PLANS.

IF THE AXIAL LOAD RESISTANCE IS NOT OBTAINED AT THIS ELEVATION, DRIVING SHALL CONTINUE UNTIL THE AXIAL LOAD RESISTANCE IS OBTAINED. THE LENGTH OF STEEL PILING SHOWN ON THE PLANS IS FOR ESTIMATING PURPOSES ONLY.

PIERS (XX" DIAMETER DRILLED SHAFTS)

FACTORED REACTION (TONS/SHAFT) = XX.X

NOMINAL UNIT BEARING RESISTANCE (TSF) = XX.X

BEARING RESISTANCE FACTOR = XX.X

FACTORED BEARING RESISTANCE (TON/SHAFT) = XX.X

NOMINAL UNIT FRICTION RESISTANCE (TSF) = XX.X

FRICTION RESISTANCE FACTOR = XX.X

FACTORED FRICTION RESISTANCE (TON/SHAFT) = XX.X

FRICTION DEPTH OF ROCK NEGLECTED (FT) = XX.X

MINIMUM DEPTH INTO FOUNDATION MATERIAL (FT) = XX.X

TOTAL FACTORED RESISTANCE (TONS/SHAFT) = XX.X

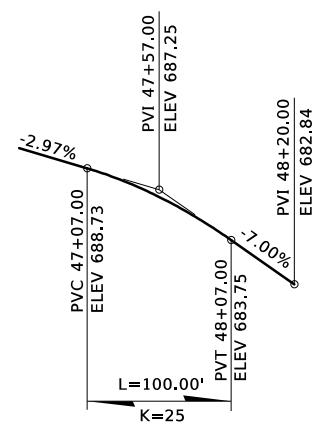

VERTICAL PROFILE DATA - 46th STREET

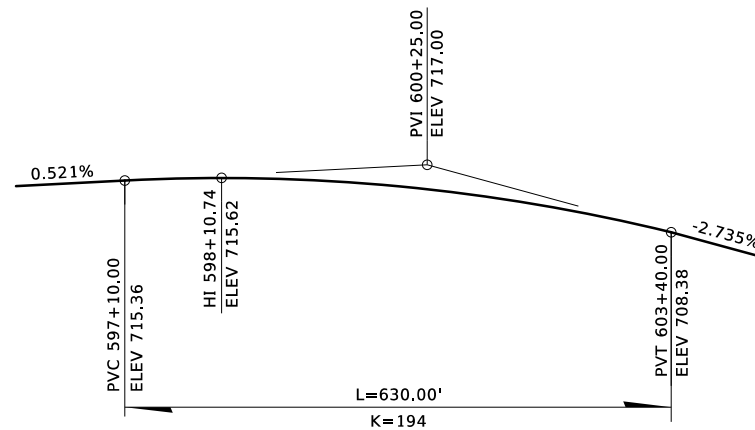

VERTICAL PROFILE DATA - CRL US-75 NB

INDEX OF SHEETS

B007 - B008	GENERAL PLAN AND ELEVATION
B009	SUPERSTRUCTURE DETAILS
B010	CONSTRUCTION PHASING

ITEMIZED QUANTITIES

ITEM	UNIT	ABUTMENT	PIER	SUPER- STRUCTURE	APPROACH SLAB	SLOPEWALL	TOTAL

BRIDGE G1, I-44 & US-75 US-75 NB OVER W. 46th ST.	TULSA COUNTY	Design	KSJ	4/20
GENERAL PLAN AND ELEVATION (SHEET 2 OF 2)		Detail	TBG	6/20
CONSTRUCT 67'-67'-50' TYPE III P.C. BEAM SPANS, 5 DEG. SKEW LF, 71'-5" CLEAR ROADWAY W/F-SHP PARAPETS, C.L. STA. 600+01.28 US-75		Check	SOT	8/20
STATE OF OKLAHOMA	DEPARTMENT OF TRANSPORTATION			
JOB PIECE NO. 33788(11)		SHEET NO. B008		

3/4/2021
P:\FDB\650-TUL\CIV\400315_0DOT_EC2123A_US75\Design-Working\STRC\Microstation\33788\WP5\Sheets\Bridge G1\33788B1.S3_GENERAL PLAN AND ELEVATION_02.dgn

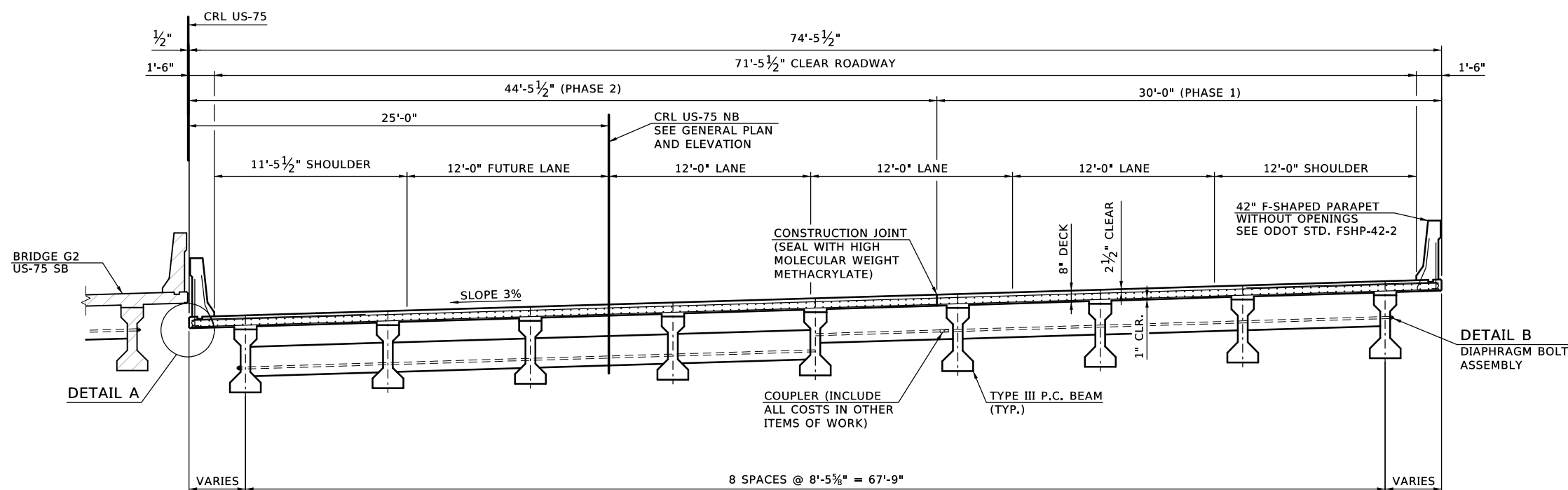

HALF SECTION AT INTERMEDIATE DIAPHRAGM

TYPICAL SECTION

HALF SECTION AT END DIAPHRAGM

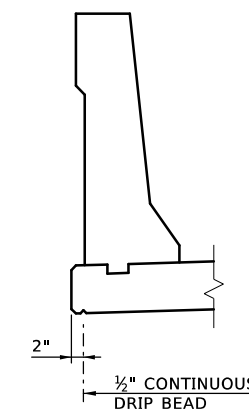

DETAIL A

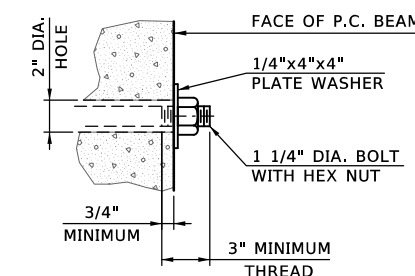

DETAIL B
DIAPHRAGM BOLT
ASSEMBLY

DIAPHRAGM BOLT NOTES

PROVIDE STRUCTURAL STEEL FOR DIAPHRAGM BOLTS AND PLATE WASHERS IN ACCORDANCE WITH AASHTO M270 (ASTM A709), GRADE 50W (WEATHERING STEEL, CHARPY V-NOTCH TESTING NOT REQUIRED). THE CONTRACTOR MAY SUBSTITUTE A #10 REINFORCING BAR IN ACCORDANCE WITH AASHTO M31, GRADE 60, AND THREADED AT THE ENDS AS SHOWN FOR THE DIAPHRAGM BOLT AT NO ADDITIONAL COST TO THE DEPARTMENT. PROVIDE HEX NUTS IN ACCORDANCE WITH AASHTO M291 (ASTM A563).
PAINT EXPOSED DIAPHRAGM BOLT, PLATE WASHER AND HEX NUT WITH TWO (2) COATS OF ZINC-RICH PAINT (6 MIL MINIMUM THICKNESS) AFTER ASSEMBLY. INCLUDE ALL COST OF DIAPHRAGM BOLT, PLATE WASHER AND HEX NUT IN THE CONTRACT PRICE FOR "STRUCTURAL STEEL M270 GRADE 50W".

DETAIL B

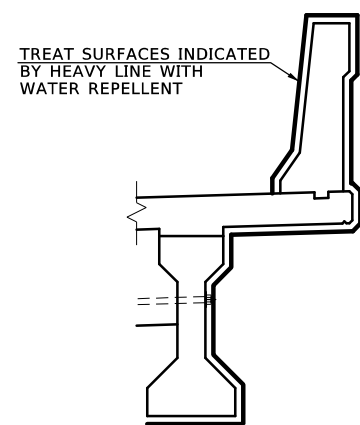

WATER REPELLENT TREATMENT DETAIL

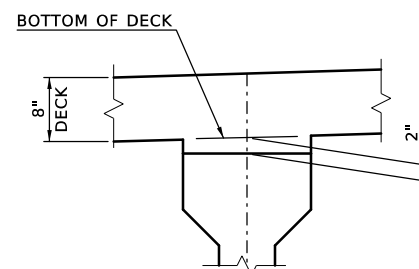

P.C. BEAM TYPE III HAUNCH DETAIL

NOTE:

PLAN QUANTITIES FOR CLASS AA CONCRETE INCLUDE BEAM HAUNCHES. THE HAUNCH HEIGHT SHOWN IS THE THEORETICAL HAUNCH HEIGHT AT THE CENTERLINE BEARING ONLY, MEASURED FROM THE BOTTOM OF THE DECK SLAB TO THE TOP OF THE BEAM, AND VARIES ACROSS THE SPAN. DETERMINE THE ACTUAL HAUNCH HEIGHT (ACCOUNTING FOR BEAM CAMBER, DEAD LOAD DEFLECTION AND ROADWAY GRADE) AFTER ERECTION OF THE BEAMS AND SUBMIT TO THE ENGINEER FOR APPROVAL. THE ENGINEER WILL NOT MEASURE DIFFERENCES BETWEEN THE THEORETICAL AND THE ACTUAL HAUNCH HEIGHTS FOR PAYMENT.

BRIDGE G1, I-44 & US-75 US-75 NB OVER W. 46th ST.	TULSA COUNTY	Design	KSJ	4/20
SUPERSTRUCTURE DETAILS		Detail	TBG	6/20
		Check	SOT	8/20
STATE OF OKLAHOMA		DEPARTMENT OF TRANSPORTATION		JOB PIECE NO. 33788(11)
				SHEET NO. B009

CONSTRUCTION PHASING NOTES

PHASE 1

SHIFT BOTH NORTH BOUND LANES WEST.

REMOVE EAST PARAPET, WINGWALLS AND EAST PORTION OF EXISTING DECK AND STRUCTURE.

CONSTRUCT NEW NORTH BOUND PORTION OF DECK AND STRUCTURE.

PHASE 2

MOVE ALL TRAFFIC EAST TO NEW PORTION OF BRIDGE.

REMOVE THE REMAINDER OF EXISTING STRUCTURE.

CONSTRUCT THE REMAINDER OF THE DECK AND STRUCTURE.

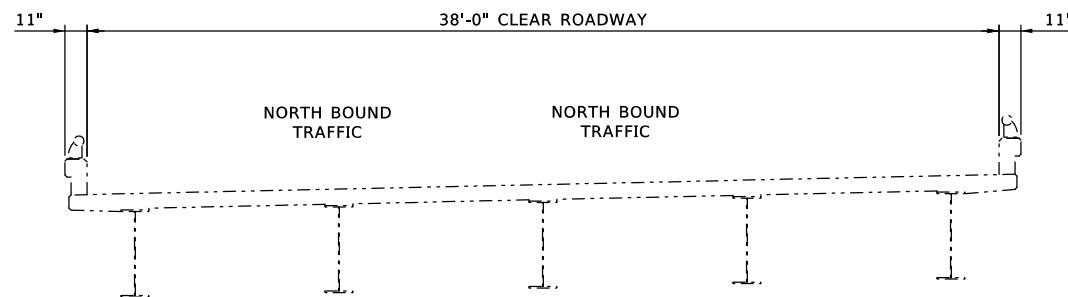

EXISTING ROADWAY

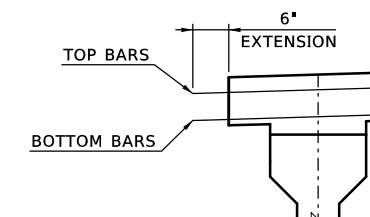

DETAIL 1

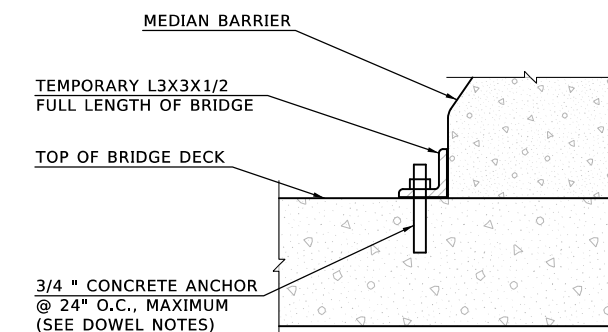
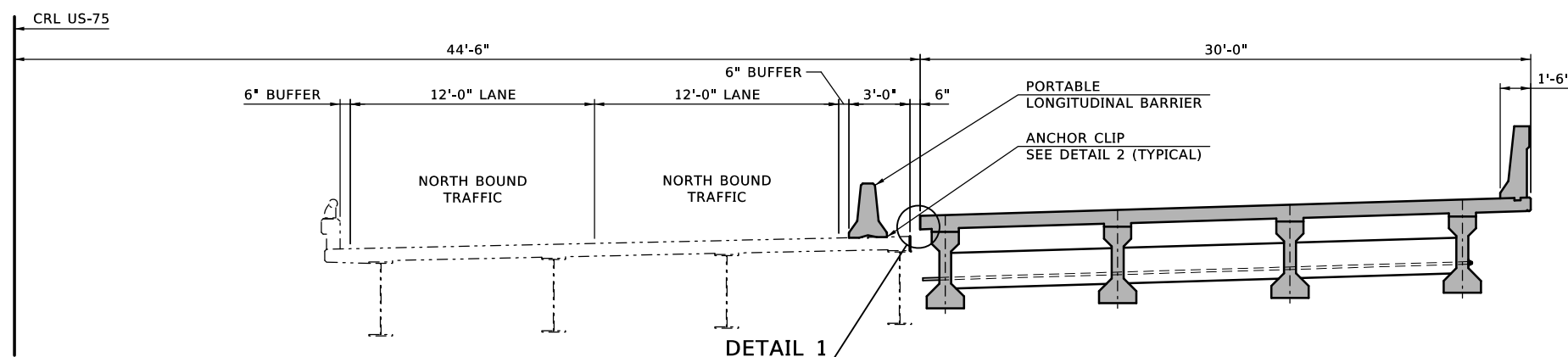

DETAIL 2

PHASE 1

DOWEL NOTES

THE CONTRACTOR SHALL SUBMIT THE TYPE OF CONCRETE ANCHOR TO THE ENGINEER FOR APPROVAL PRIOR TO INSTALLATION OF ANCHORS. ANCHORS SHALL HAVE A MINIMUM ULTIMATE PULLOUT CAPACITY OF 10 kip AND A MINIMUM ULTIMATE SHEAR CAPACITY OF 13 kip. WHEN ANGLE IS REMOVED, ALL HOLES WILL BE FILLED IN A MANNER APPROVED BY THE ENGINEER. ALL COSTS OF ANGLES AND 3/4" DIA. CONCRETE ANCHORS (WITH WASHERS) SHALL BE PAID FOR UNDER OTHER ITEMS OF WORK.

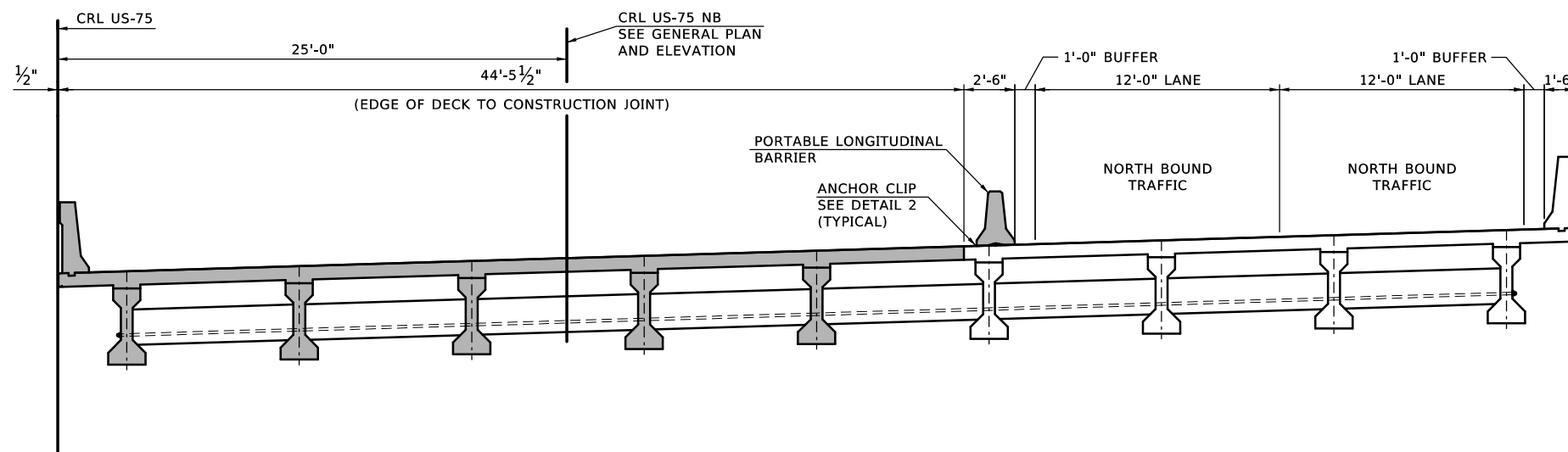

PHASE 2

LEGEND

NEW CONSTRUCTION [shaded box]

BRIDGE G1, I-44 & US-75		TULSA COUNTY		Design	KSJ	4/20
US-75 NB OVER W. 46th ST.				Detail	TBG	6/20
				Check	SOT	8/20
CONSTRUCTION PHASING				BENHAM		
STATE OF OKLAHOMA		DEPARTMENT OF TRANSPORTATION		JOB PIECE NO. 33788(11) SHEET NO. B010		

3/4/2021
P:\FDB\650-TUL\CIV\400315_0DOT_EC2123A_US75\Design-Working\STRC\Microstation\3378811\WP5\Sheets\Bridges\G2\3378811S4_GENERAL_PLAN_AND_ELEVATION_01.dgn

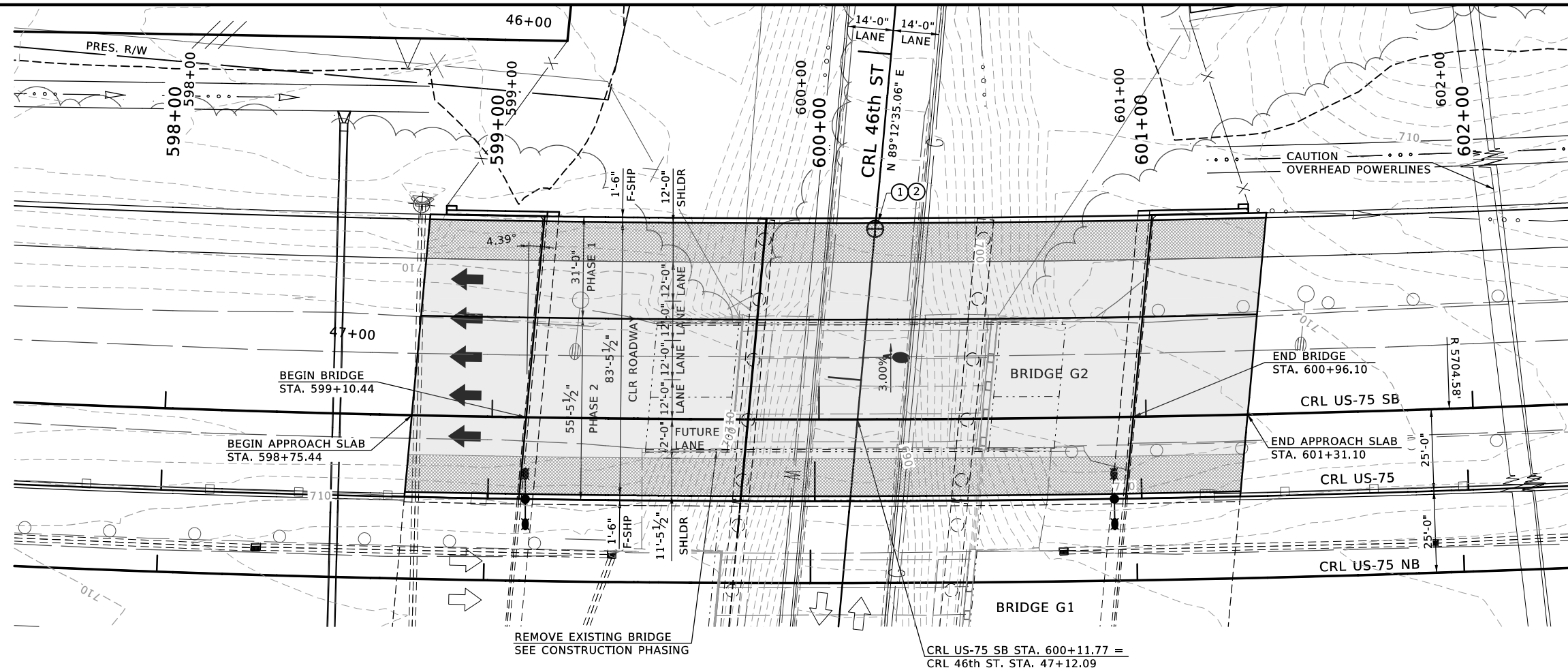

PLAN

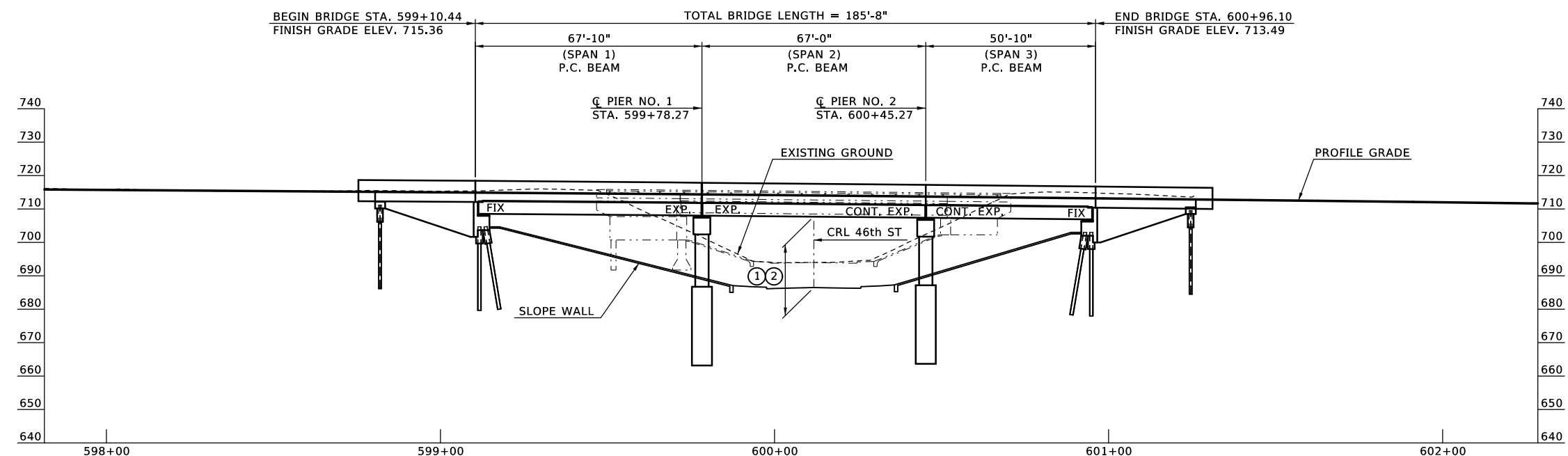

ELEVATION

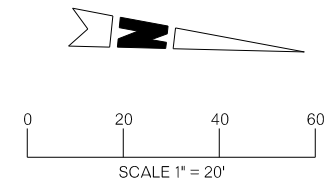

BENCHMARK 104
 CUT X
 STA. 296+23.28, 74.83' LT CLS US-75
 STA. 605+00.76, 75.15' LT CRL US-75
 N 405877.59, E 2557190.54, EL. 700.966

BENCHMARK 105
 CUT X
 STA. 290+00.39, 89.22' LT CLS US-75
 STA. 598+77.83, 89.44' LT CRL US-75
 N 405267.83, E 2557261.24, EL. 706.515

- ① INTERIM MIN. VERTICAL CLEARANCE 13'-8"
 CRL US-75 SB STA. 600+17.32
 OFFSET 58'-3" RT
 BASED ON SUGGESTED CONSTRUCTION SEQUENCE
- ② PROPOSED MIN. VERTICAL CLEARANCE 21'-4"
 CRL US-75 SB STA. 600+17.32
 OFFSET 58'-3" RT
 BASED ON ULTIMATE 46TH STREET PGL

NOTES:
 FOR DESIGN DATA, VERTICAL PROFILE DATA,
 AND FOUNDATION DATA SEE SHEET NO. B012.

BRIDGE G2, I-44 & US-75 US-75 SB OVER W. 46th ST.		TULSA COUNTY		Design	KSJ	4/20
GENERAL PLAN AND ELEVATION (SHEET 1 OF 2)				Detail	TBG	6/20
CONSTRUCT 67'-67'-50' TYPE III P.C. BEAM SPANS, 5 DEG. SKEW LF, 83'-5" CLEAR ROADWAY W/F-SHP PARAPETS, C.L. STA. 600+03.27 US-75				Check	SOT	8/20
STATE OF OKLAHOMA		DEPARTMENT OF TRANSPORTATION		JOB PIECE NO. 33788(11)		
				SHEET NO. B011		

REMOVE EXISTING BRIDGE @ STA. 600+11.77 US-75
 80' SINGLE SPAN STEEL GIRDER, 38' CLEAR ROADWAY

3/4/2021

P:\FDB\650-TUL\CV\400315.0DOT_EC2123A_US75\Design-Working\STRC\Microstation\3378811\WP5\Sheets\Bridges\G2\3378811\4 TYPICAL SECTION.dgn

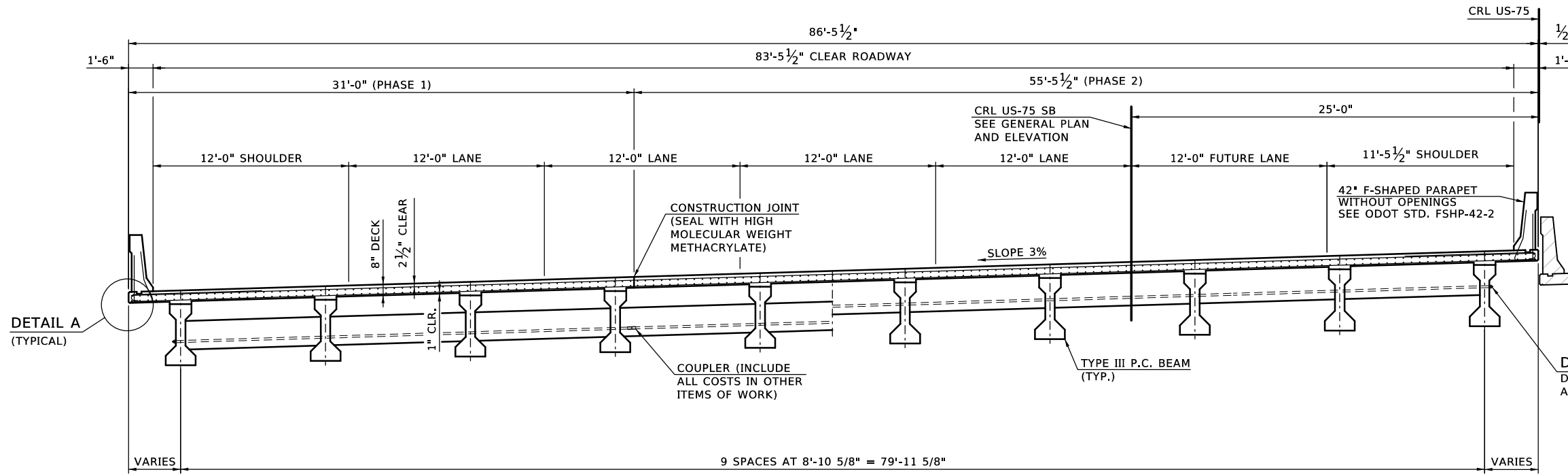

HALF SECTION AT INTERMEDIATE DIAPHRAGM

TYPICAL SECTION

HALF SECTION AT END DIAPHRAGM

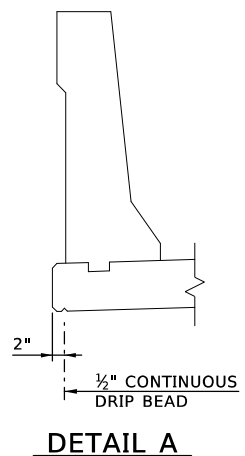

DETAIL A

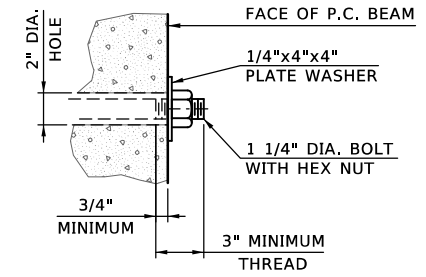

DIAPHRAGM BOLT NOTES

PROVIDE STRUCTURAL STEEL FOR DIAPHRAGM BOLTS AND PLATE WASHERS IN ACCORDANCE WITH AASHTO M270 (ASTM A709), GRADE 50W (WEATHERING STEEL, CHARPY V-NOTCH TESTING NOT REQUIRED). THE CONTRACTOR MAY SUBSTITUTE A #10 REINFORCING BAR IN ACCORDANCE WITH AASHTO M31, GRADE 60, AND THREADED AT THE ENDS AS SHOWN FOR THE DIAPHRAGM BOLT AT NO ADDITIONAL COST TO THE DEPARTMENT. PROVIDE HEX NUTS IN ACCORDANCE WITH AASHTO M291 (ASTM A563). PAINT EXPOSED DIAPHRAGM BOLT, PLATE WASHER AND HEX NUT WITH TWO (2) COATS OF ZINC-RICH PAINT (6 MIL MINIMUM THICKNESS) AFTER ASSEMBLY. INCLUDE ALL COST OF DIAPHRAGM BOLT, PLATE WASHER AND HEX NUT IN THE CONTRACT PRICE FOR "STRUCTURAL STEEL M270 GRADE 50W".

DETAIL B

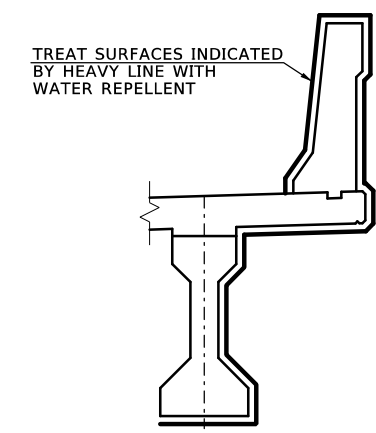

WATER REPELLENT TREATMENT DETAIL

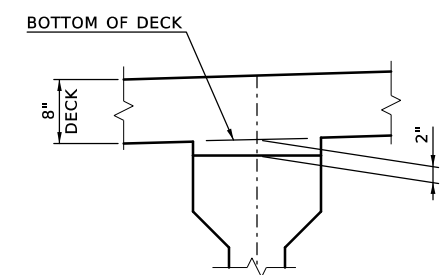

P.C. BEAM TYPE III HAUNCH DETAIL

NOTE:
 PLAN QUANTITIES FOR CLASS AA CONCRETE INCLUDE BEAM HAUNCHES. THE HAUNCH HEIGHT SHOWN IS THE THEORETICAL HAUNCH HEIGHT AT THE CENTERLINE BEARING ONLY, MEASURED FROM THE BOTTOM OF THE DECK SLAB TO THE TOP OF THE BEAM, AND VARIES ACROSS THE SPAN. DETERMINE THE ACTUAL HAUNCH HEIGHT (ACCOUNTING FOR BEAM CAMBER, DEAD LOAD DEFLECTION AND ROADWAY GRADE) AFTER ERECTION OF THE BEAMS AND SUBMIT TO THE ENGINEER FOR APPROVAL. THE ENGINEER WILL NOT MEASURE DIFFERENCES BETWEEN THE THEORETICAL AND THE ACTUAL HAUNCH HEIGHTS FOR PAYMENT.

BRIDGE G2, I-44 & US-75 US-75 SB OVER W. 46th ST.		TULSA COUNTY		Design	KSJ	4/20
				Detail	TBG	6/20
				Check	SOT	8/20
SUPERSTRUCTURE DETAILS						
STATE OF OKLAHOMA		DEPARTMENT OF TRANSPORTATION			JOB PIECE NO. 33788(11)	
					SHEET NO. B013	



CONSTRUCTION PHASING NOTES

PHASE 1

NO CHANGE IN TRAFFIC.

CONSTRUCT NEW SOUTH BOUND PORTION OF DECK AND STRUCTURE.

PHASE 2

MOVE ALL TRAFFIC TO NEW PORTION OF BRIDGE.

REMOVE THE EXISTING STRUCTURE.

CONSTRUCT THE REMAINDER OF THE DECK AND STRUCTURE.

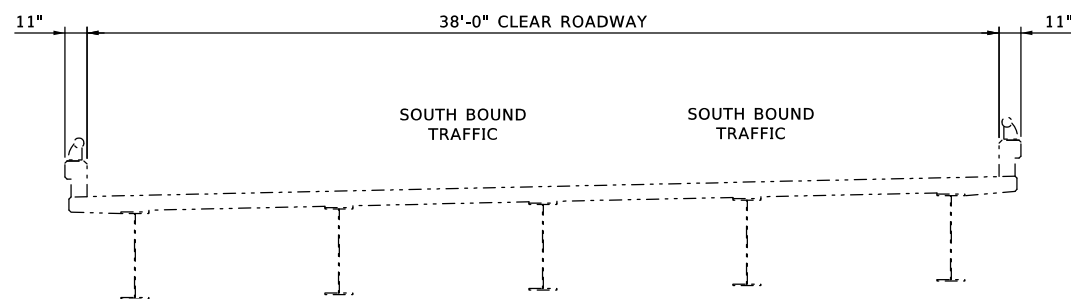

EXISTING ROADWAY

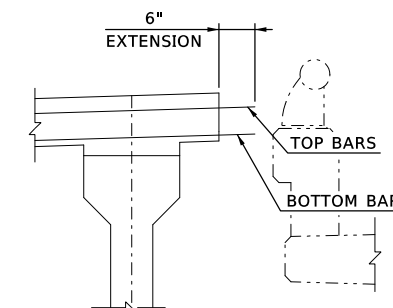

DETAIL 1

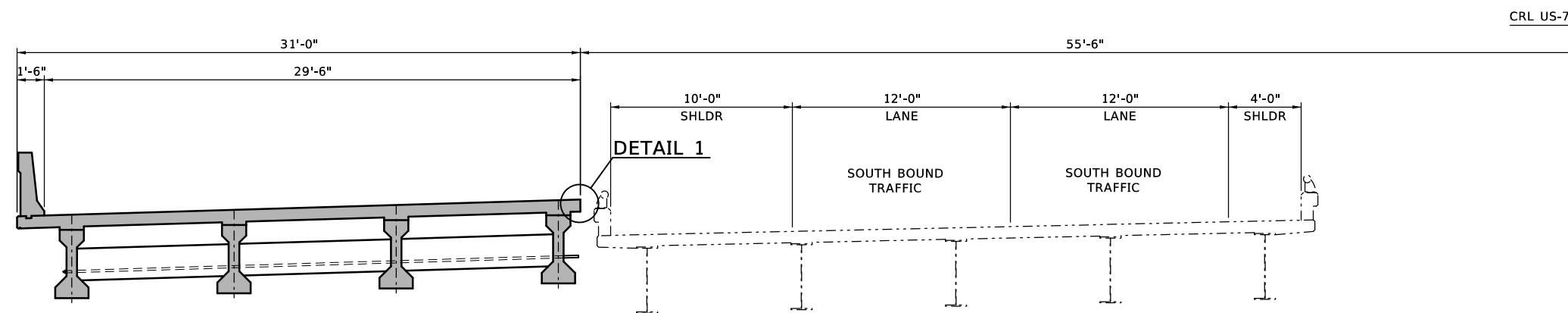

PHASE 1

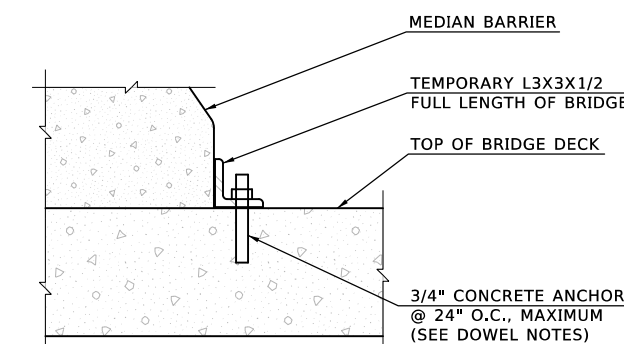

DETAIL 2

DOWEL NOTES

THE CONTRACTOR SHALL SUBMIT THE TYPE OF CONCRETE ANCHOR TO THE ENGINEER FOR APPROVAL PRIOR TO INSTALLATION OF ANCHORS. ANCHORS SHALL HAVE A MINIMUM ULTIMATE PULLOUT CAPACITY OF 10 kip AND A MINIMUM ULTIMATE SHEAR CAPACITY OF 13 kip. WHEN ANGLE IS REMOVED, ALL HOLES WILL BE FILLED IN A MANNER APPROVED BY THE ENGINEER. ALL COSTS OF ANGLES AND 3/4" DIA. CONCRETE ANCHORS (WITH WASHERS) SHALL BE PAID FOR UNDER OTHER ITEMS OF WORK.

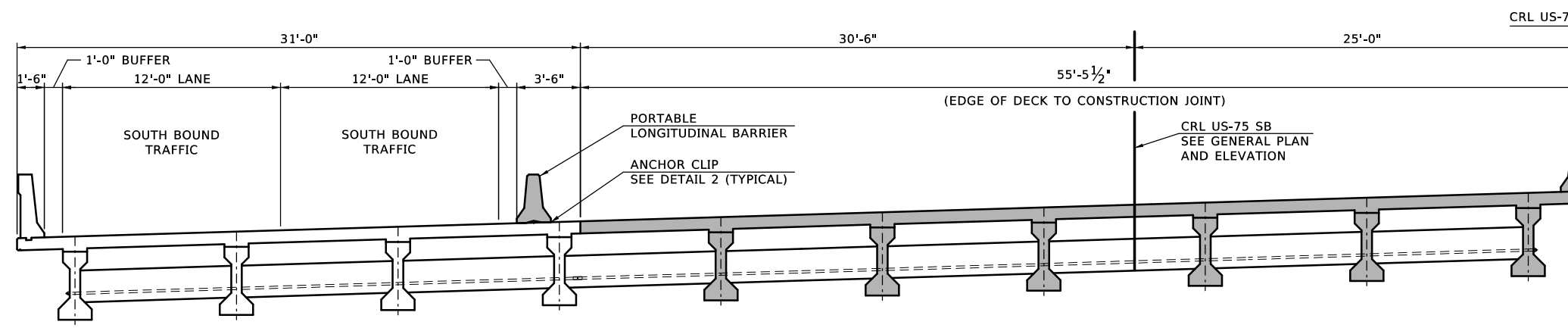

PHASE 2

LEGEND

NEW CONSTRUCTION [shaded box]

BRIDGE G2, I-44 & US-75		TULSA COUNTY		Design	KSJ	4/20
US-75 SB OVER W. 46th ST.				Detail	TBG	6/20
				Check	SOT	8/20
CONSTRUCTION PHASING						
STATE OF OKLAHOMA		DEPARTMENT OF TRANSPORTATION			JOB PIECE NO. 33788(11)	
						SHEET NO. B014



R/W UTILITY MEETING

MARCH 2021

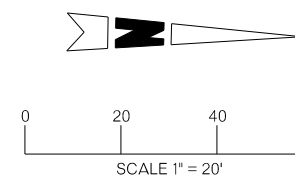

BENCHMARK 108A
CUT X
STA. 275+13.76, 115.40' LT CLS US-75
STA. 583+91.21, 115.56' LT CRL US-75
N 403787.17, E 2557276.90, EL. 682.821

BENCHMARK 108
3/8IPC
STA. 276+99.78, 63.16' LT CLS US-75
STA. 585+77.23, 63.32' LT CRL US-75
N 403974.23, E 2557325.32, EL. 706.998

BENCHMARK 107
5/8IP ALUM CAP
STA. 282+04.18, 138.73' LT CLS US-75
STA. 590+81.63, 138.89' LT CRL US-75
N 404476.97, E 2557239.46, EL. 701.479

BENCHMARK 106
CUT X
STA. 282+82.18, 109.02' LT CLS US-75
STA. 591+59.63, 109.18' LT CRL US-75
N 404555.57, E 2557267.57, EL. 701.263

① PROPOSED MIN. VERTICAL CLEARANCE 17'-5"
CRL US-75 NB STA. 582+85.85, 43'-6" RT.

NOTES:
FOR DESIGN DATA, VERTICAL PROFILE DATA, AND
FOUNDATION DATA SEE SHEET NO. B016.

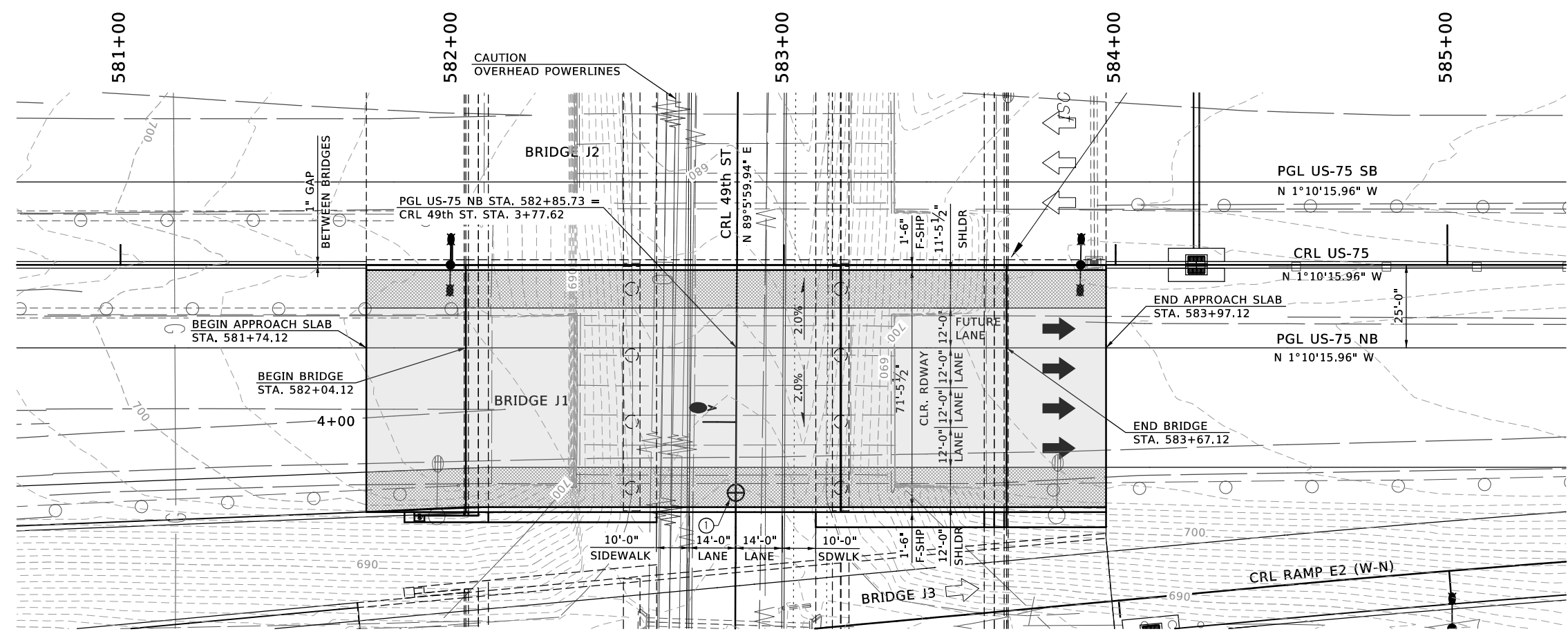

PLAN

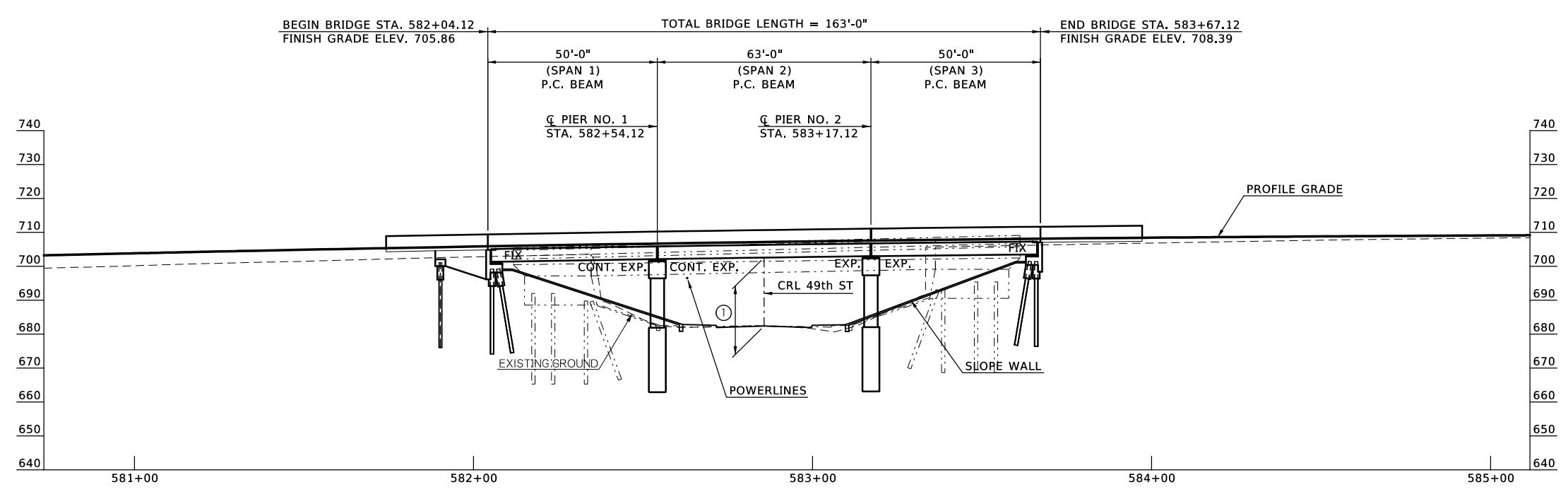

ELEVATION

BRIDGE J1, I-44 & US-75		TULSA COUNTY		Design	KSJ	4/20
US-75 NB OVER W. 49th ST.				Detail	TBG	6/20
GENERAL PLAN AND ELEVATION				Check	SOT	8/20
(SHEET 1 OF 2)						
CONSTRUCT 50'-63'-50' TYPE III P.C. BEAM SPANS, 71'-5" CLEAR ROADWAY W/F-SHP PARAPETS, CL. STA. 582+85.62 US-75						
STATE OF OKLAHOMA		DEPARTMENT OF TRANSPORTATION		JOB PIECE NO. 33788(11) SHEET NO. B015		

REMOVE EXISTING BRIDGE @ STA. 582+85.62 US-75
100' SINGLE SPAN STEEL GIRDER, 50'-8" CLEAR ROADWAY

3/4/2021
P:\FDB\650-TUL\CIV\400315.0DOT_EC2123A_US75\Design-Working\STRC\Microstation\33788\WP5\Sheets\Bridges\33788\SS GENERAL PLAN AND ELEVATION 01.dgn

3/4/2021

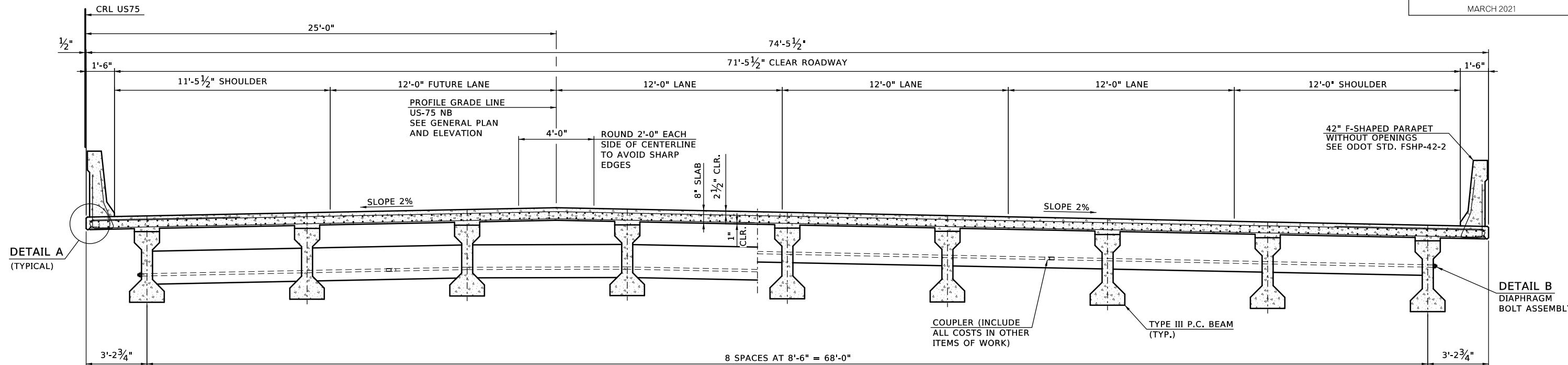

HALF SECTION AT INTERMEDIATE DIAPHRAGM

HALF SECTION AT END DIAPHRAGM

TYPICAL SECTION

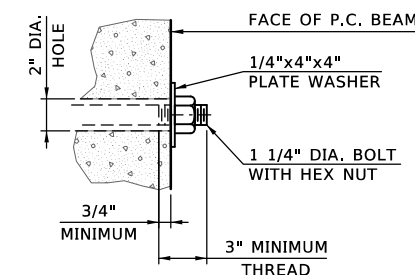

DIAPHRAGM BOLT NOTES

PROVIDE STRUCTURAL STEEL FOR DIAPHRAGM BOLTS AND PLATE WASHERS IN ACCORDANCE WITH AASHTO M270 (ASTM A709), GRADE 50W (WEATHERING STEEL, CHARPY V-NOTCH TESTING NOT REQUIRED). THE CONTRACTOR MAY SUBSTITUTE A #10 REINFORCING BAR IN ACCORDANCE WITH AASHTO M31, GRADE 60, AND THREADED AT THE ENDS AS SHOWN FOR THE DIAPHRAGM BOLT AT NO ADDITIONAL COST TO THE DEPARTMENT. PROVIDE HEX NUTS IN ACCORDANCE WITH AASHTO M291 (ASTM A563). PAINT EXPOSED DIAPHRAGM BOLT, PLATE WASHER AND HEX NUT WITH TWO (2) COATS OF ZINC-RICH PAINT (6 MIL MINIMUM THICKNESS) AFTER ASSEMBLY. INCLUDE ALL COST OF DIAPHRAGM BOLT, PLATE WASHER AND HEX NUT IN THE CONTRACT PRICE FOR "STRUCTURAL STEEL M270 GRADE 50W".

DETAIL B

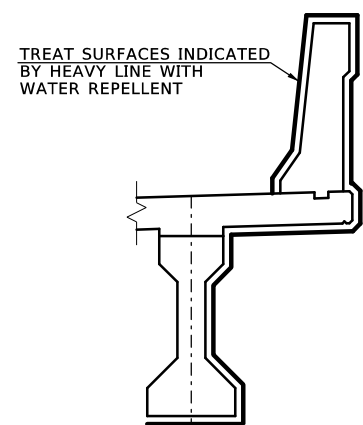

WATER REPELLENT TREATMENT DETAIL

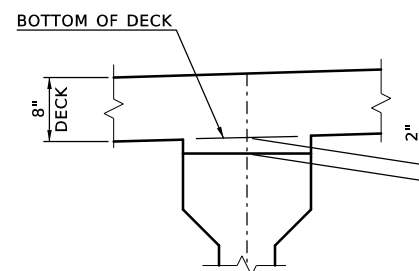

P.C. BEAM TYPE III HAUNCH DETAIL

NOTE:

PLAN QUANTITIES FOR CLASS AA CONCRETE INCLUDE BEAM HAUNCHES. THE HAUNCH HEIGHT SHOWN IS THE THEORETICAL HAUNCH HEIGHT AT THE CENTERLINE BEARING ONLY, MEASURED FROM THE BOTTOM OF THE DECK SLAB TO THE TOP OF THE BEAM, AND VARIES ACROSS THE SPAN. DETERMINE THE ACTUAL HAUNCH HEIGHT (ACCOUNTING FOR BEAM CAMBER, DEAD LOAD DEFLECTION AND ROADWAY GRADE) AFTER ERECTION OF THE BEAMS AND SUBMIT TO THE ENGINEER FOR APPROVAL. THE ENGINEER WILL NOT MEASURE DIFFERENCES BETWEEN THE THEORETICAL AND THE ACTUAL HAUNCH HEIGHTS FOR PAYMENT.

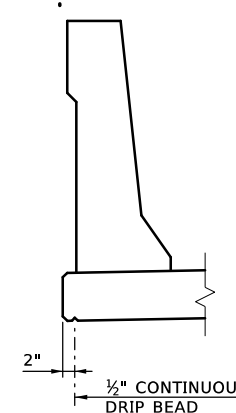

DETAIL A

BRIDGE J1, I-44 & US-75 US-75 NB OVER W. 49th ST.		TULSA COUNTY		Design	KSJ	4/20
SUPERSTRUCTURE DETAILS				Detail	TBG	6/20
				Check	SOT	8/20
STATE OF OKLAHOMA		DEPARTMENT OF TRANSPORTATION		JOB PIECE NO. 33788(11)		
						SHEET NO. B017

P:\FDB\650-TUL\CIV\400315_0DOT_EC2123A_US75\Design-Working\STRC\Microstation\33788\WP5\Sheets\Bridg J\33788\155 TYPICAL SECTION.dgn

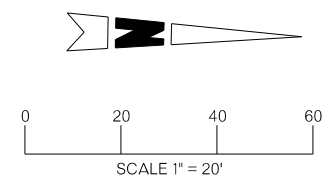

BENCHMARK 108A
 CUT X
 STA. 275+13.76, 115.40' LT CLS US-75
 STA. 583+91.21, 115.56' LT CRL US-75
 N 403787.17, E 2557276.90, EL. 682.821

BENCHMARK 108
 3/8" IPC
 STA. 276+99.78, 63.16' LT CLS US-75
 STA. 585+77.23, 63.32' LT CRL US-75
 N 403974.23, E 2557325.32, EL. 706.998

BENCHMARK 107
 5/8" IP ALUM CAP
 STA. 282+04.18, 138.73' LT CLS US-75
 STA. 590+81.63, 138.89' LT CRL US-75
 N 404476.97, E 2557239.46, EL. 701.479

BENCHMARK 106
 CUT X
 STA. 282+82.18, 109.02' LT CLS US-75
 STA. 591+59.63, 109.18' LT CRL US-75
 N 404555.57, E 2557267.57, EL. 701.263

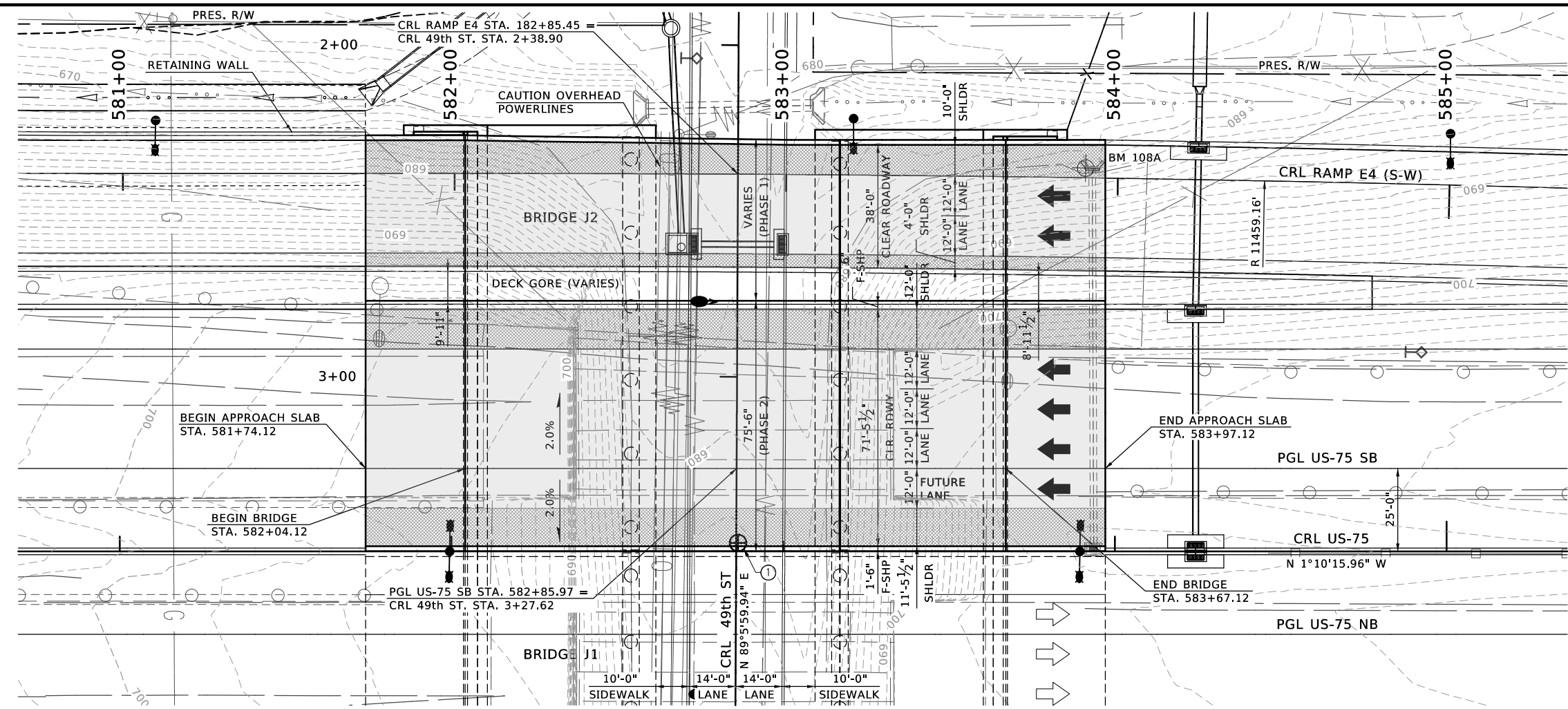

PLAN

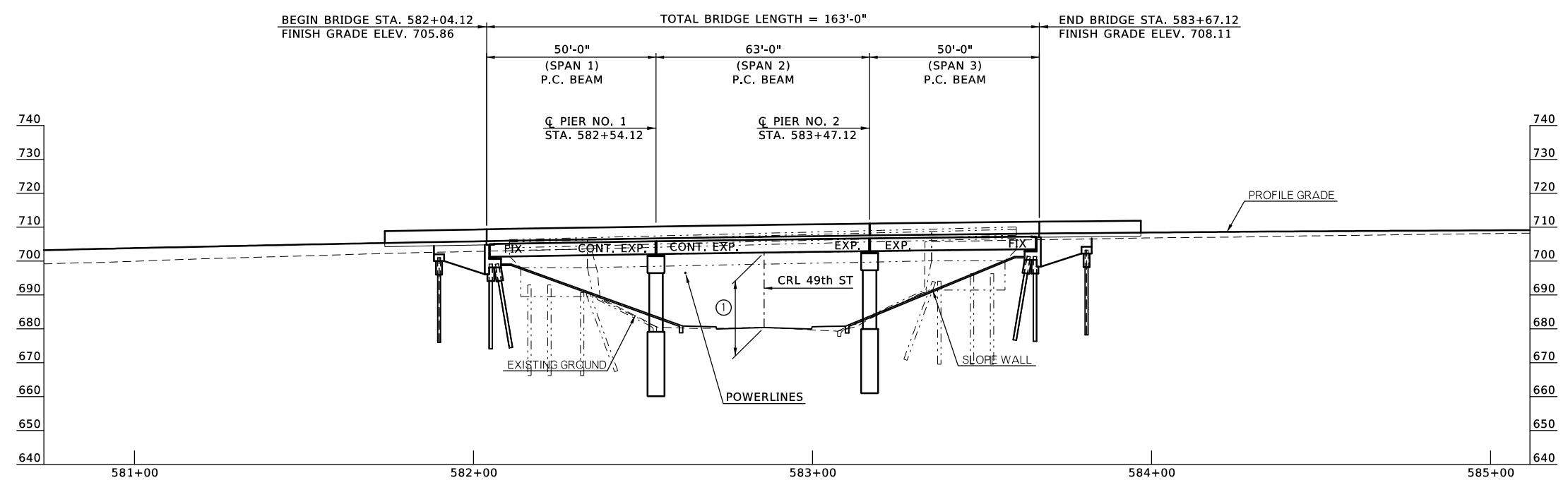

ELEVATION

① PROPOSED MIN. VERTICAL CLEARANCE 21'-0" CRL US-75 SB STA. 582+85.85, 22'-5" LT.

NOTES:
 FOR DESIGN DATA, VERTICAL PROFILE DATA, AND FOUNDATION DATA SEE SHEET NO. B019.

BRIDGE J2, I-44 & US-75 US-75 SB OVER W. 49th ST.	TULSA COUNTY	Design	KSJ	4/20
GENERAL PLAN AND ELEVATION (SHEET 1 OF 2)		Detail	TBG	6/20
		Check	SOT	8/20
CONSTRUCT 50'-63'-50' TYPE III P.C. BEAM SPANS, 71'-5" CLEAR ROADWAY AND 38'-0" CLEAR ROADWAY W/F-SHP PARAPETS, CL. STA. 582+85.62 US-75		BENHAM ENGINEERS		
STATE OF OKLAHOMA	DEPARTMENT OF TRANSPORTATION			

REMOVE EXISTING BRIDGE @ STA. 582+85.85 US-75
 100' SINGLE SPAN STEEL GIRDER, TAPERED ROADWAY

P:\FDB\650-TUL\CV\400315_0DOT_EC2123A_US75\Design-Working\STRC\Microstation\33788\WP5\Sheets\Bridges\J2\33788\I56 GENERAL PLAN AND ELEVATION Old.dgn
 3/4/2021

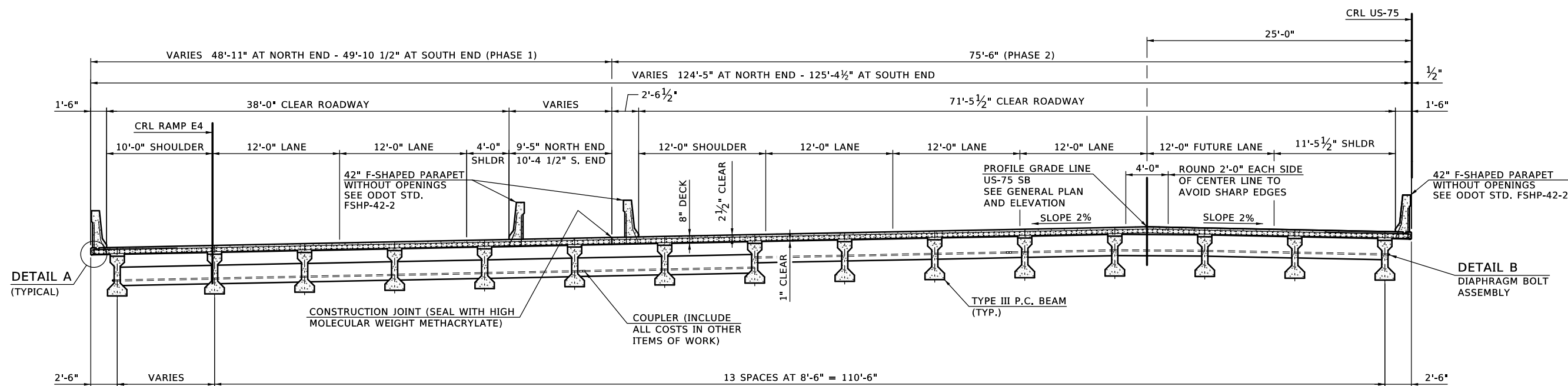

HALF SECTION AT INTERMEDIATE DIAPHRAGM

TYPICAL SECTION

HALF SECTION AT END DIAPHRAGM

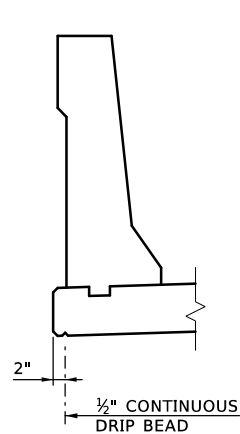

DETAIL A

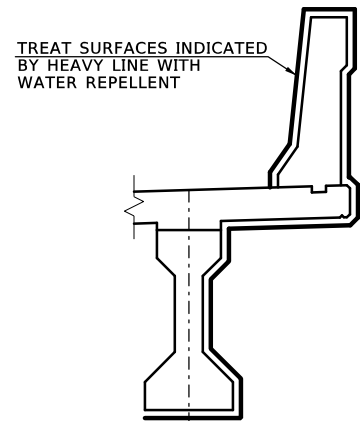

WATER REPELLENT TREATMENT DETAIL

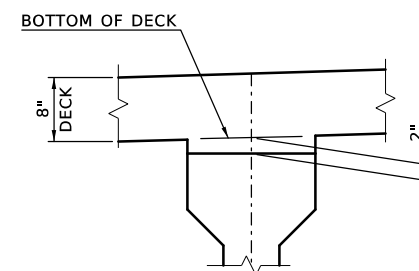

P.C. BEAM TYPE III HAUNCH DETAIL

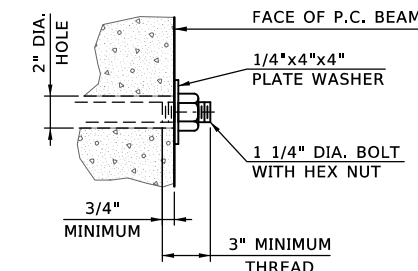

DIAPHRAGM BOLT NOTES

PROVIDE STRUCTURAL STEEL FOR DIAPHRAGM BOLTS AND PLATE WASHERS IN ACCORDANCE WITH AASHTO M270 (ASTM A709), GRADE 50W (WEATHERING STEEL, CHARPY V-NOTCH TESTING NOT REQUIRED). THE CONTRACTOR MAY SUBSTITUTE A #10 REINFORCING BAR IN ACCORDANCE WITH AASHTO M31, GRADE 60, AND THREADED AT THE ENDS AS SHOWN FOR THE DIAPHRAGM BOLT AT NO ADDITIONAL COST TO THE DEPARTMENT. PROVIDE HEX NUTS IN ACCORDANCE WITH AASHTO M291 (ASTM A563). PAINT EXPOSED DIAPHRAGM BOLT, PLATE WASHER AND HEX NUT WITH TWO (2) COATS OF ZINC-RICH PAINT (6 MIL MINIMUM THICKNESS) AFTER ASSEMBLY. INCLUDE ALL COST OF DIAPHRAGM BOLT, PLATE WASHER AND HEX NUT IN THE CONTRACT PRICE FOR "STRUCTURAL STEEL M270 GRADE 50W".

DETAIL B

NOTE:

PLAN QUANTITIES FOR CLASS AA CONCRETE INCLUDE BEAM HAUNCHES. THE HAUNCH HEIGHT SHOWN IS THE THEORETICAL HAUNCH HEIGHT AT THE CENTERLINE BEARING ONLY, MEASURED FROM THE BOTTOM OF THE DECK SLAB TO THE TOP OF THE BEAM, AND VARIES ACROSS THE SPAN. DETERMINE THE ACTUAL HAUNCH HEIGHT (ACCOUNTING FOR BEAM CAMBER, DEAD LOAD DEFLECTION AND ROADWAY GRADE) AFTER ERECTION OF THE BEAMS AND SUBMIT TO THE ENGINEER FOR APPROVAL. THE ENGINEER WILL NOT MEASURE DIFFERENCES BETWEEN THE THEORETICAL AND THE ACTUAL HAUNCH HEIGHTS FOR PAYMENT.

BRIDGE J2, I-44 & US-75 US-75 SB OVER W. 49th ST.	TULSA COUNTY	Design	KSJ	4/20
SUPERSTRUCTURE DETAILS		Detail	TBG	6/20
		Check	SOT	8/20
STATE OF OKLAHOMA		DEPARTMENT OF TRANSPORTATION		JOB PIECE NO. 33788(11)
				SHEET NO. B020



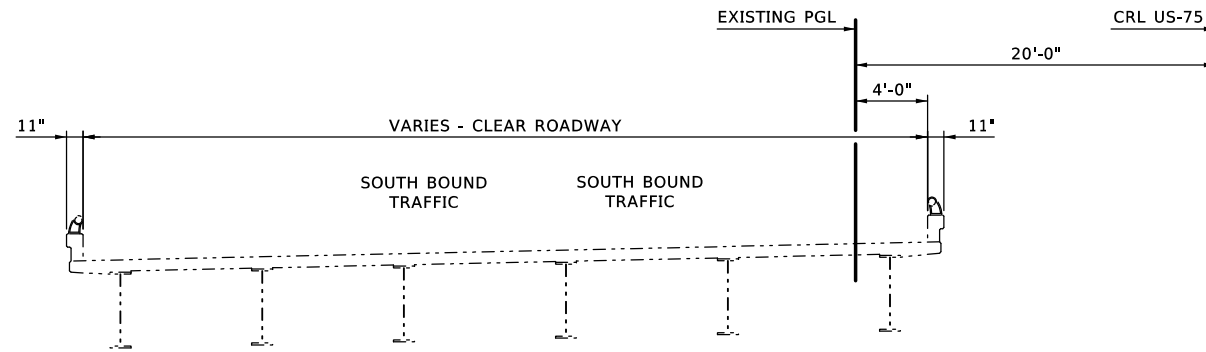

EXISTING ROADWAY

CONSTRUCTION PHASING NOTES

PHASE 1

NO CHANGE IN TRAFFIC.

CONSTRUCT NEW SOUTH BOUND PORTION OF DECK AND STRUCTURE.

PHASE 2

MOVE SOUTH BOUND TRAFFIC ON TEMPORARY CROSSOVER TO EXISTING US-75 NORTH BOUND.

REMOVE THE EXISTING STRUCTURE.

CONSTRUCT THE REMAINDER OF THE DECK AND STRUCTURE.

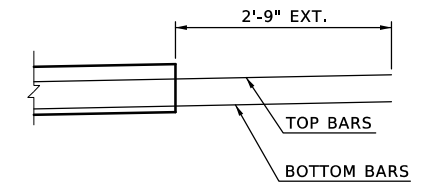

DETAIL 1

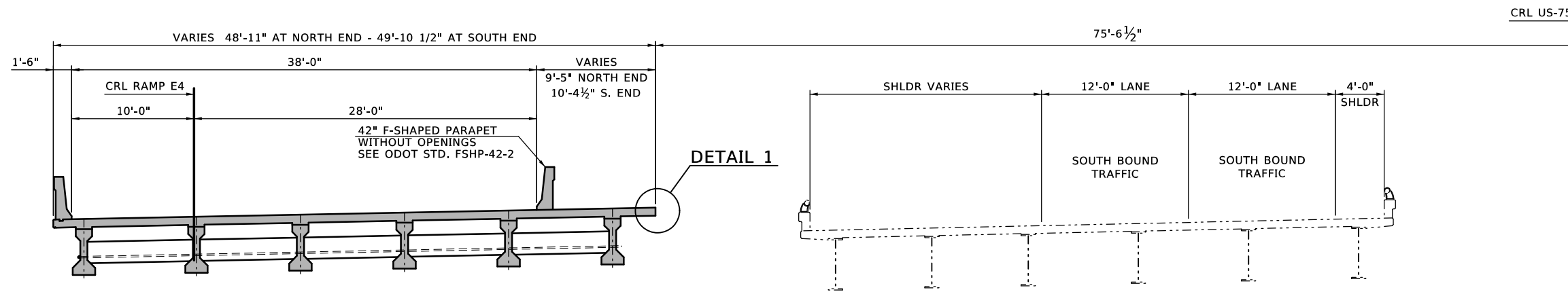

PHASE 1

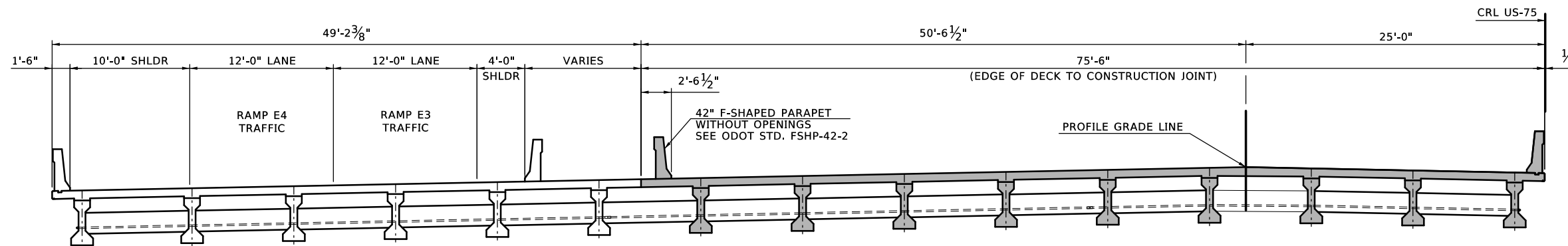

PHASE 2

LEGEND

NEW CONSTRUCTION

BRIDGE J2, I-44 & US-75		TULSA COUNTY		Design	KSJ	4/20
US-75 SB OVER W. 49th ST.				Detail	TBG	6/20
				Check	SOT	8/20
CONSTRUCTION PHASING						
STATE OF OKLAHOMA		DEPARTMENT OF TRANSPORTATION		JOB PIECE NO. 33788(11) SHEET NO. B021		

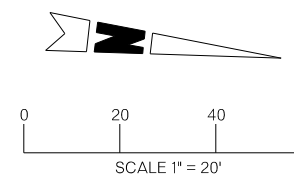

BENCHMARK 108A
 CUT X
 STA. 275+13.76, 115.40' LT CLS US-75
 STA. 583+91.21, 115.56' LT CRL US-75
 N 403787.17, E 2557276.90, EL. 682.821

BENCHMARK 108
 3/8" IPC
 STA. 276+99.78, 63.16' LT CLS US-75
 STA. 585+77.23, 63.32' LT CRL US-75
 N 403974.23, E 2557325.32, EL. 706.998

BENCHMARK 107
 5/8" ALUM CAP
 STA. 282+04.18, 138.73' LT CLS US-75
 STA. 590+81.63, 138.89' LT CRL US-75
 N 404476.97, E 2557239.46, EL. 701.479

BENCHMARK 106
 CUT X
 STA. 282+82.18, 109.02' LT CLS US-75
 STA. 591+59.63, 109.18' LT CRL US-75
 N 404555.57, E 2557267.57, EL. 701.263

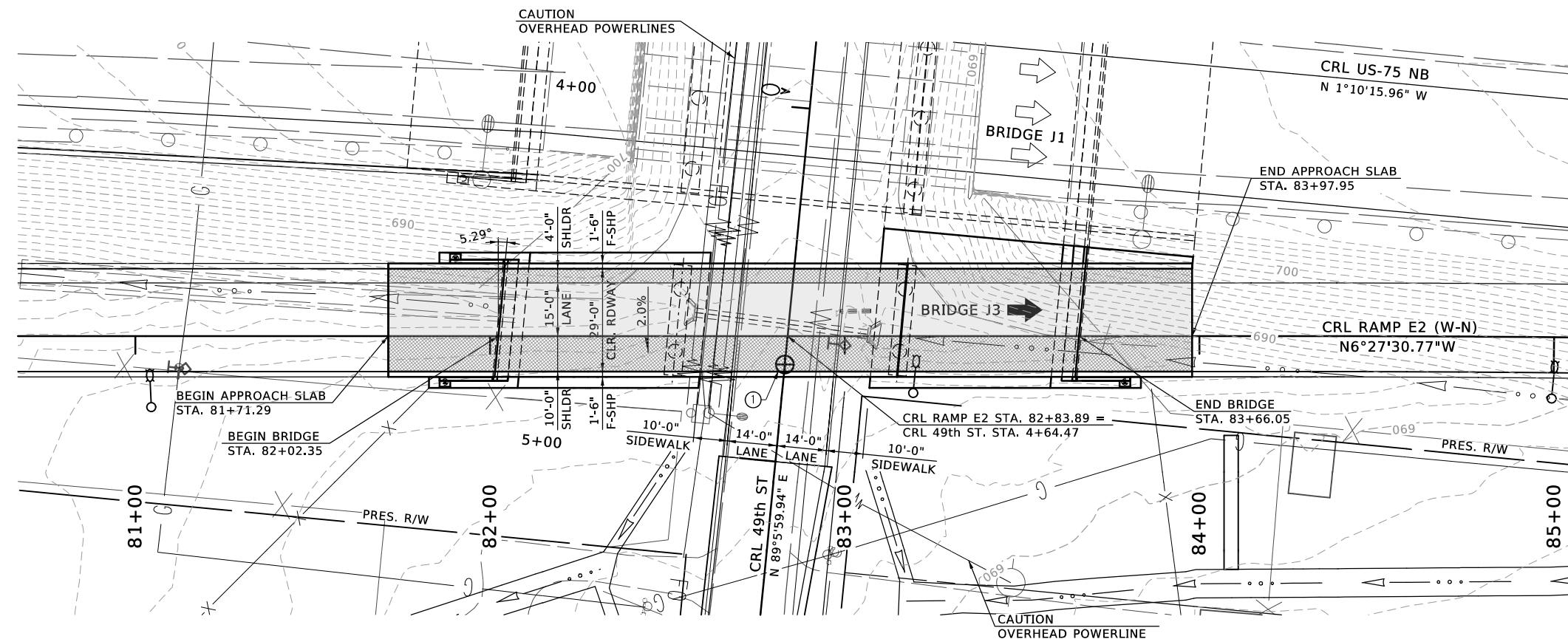

PLAN

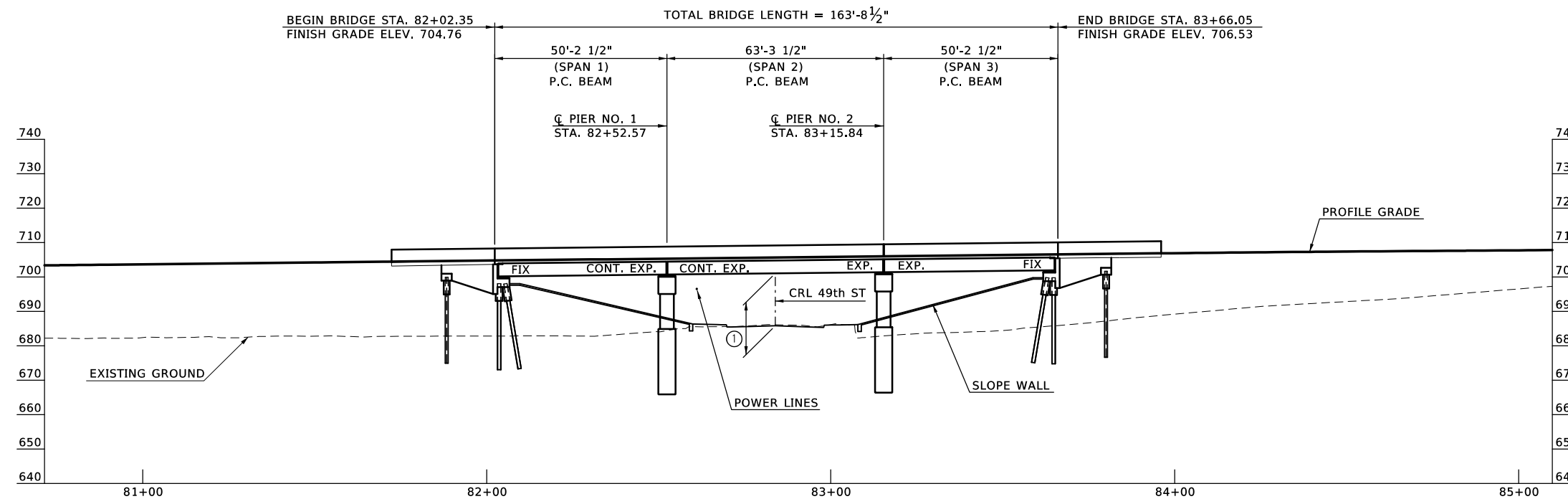

ELEVATION

① PROPOSED MIN. VERTICAL CLEARANCE 14'-8"
 CRL RAMP E2 STA. 82+83.89, 9'-0" RT.

NOTES:
 FOR DESIGN DATA, VERTICAL PROFILE DATA, AND
 FOUNDATION DATA SEE SHEET NO. B023.

BRIDGE J3, I-44 & US-75		TULSA COUNTY		Design	KSJ	4/20
RAMP E2 OVER W. 49th ST.				Detail	TBG	6/20
GENERAL PLAN AND ELEVATION				Check	SOT	8/20
(SHEET 1 OF 2)						
CONSTRUCT 50'-63'-50' TYPE III P.C. BEAM SPANS, 5 DEG. SKEW LF, 29'-0" CLEAR ROADWAY W/F-SHP PARAPETS, C.L. STA. 82+84.20 RAMP E2		STATE OF OKLAHOMA		DEPARTMENT OF TRANSPORTATION		SHEET NO. B022
		JOB PIECE NO. 33788(11)				

DESIGN DATA

LOAD AND RESISTANCE FACTOR DESIGN

CLASS AA CONCRETE	f'c = 4,000 PSI
CLASS A CONCRETE	f'c = 3,000 PSI
REINFORCING STEEL (GRADE 60)	Fy = 60,000 PSI
STRUCTURAL STEEL M270 (GRADE 50W)	Fy = 50,000 PSI
STAINLESS STEEL A240 (TYPE 316)	Fy = 30,000 PSI
STAINLESS STEEL A320, CLASS 2, (GRADE B8M)	Fy = 58,000 PSI

LOADING: HL-93 OR OKLAHOMA OVERLOAD TRUCK
20 PSF FUTURE WEARING SURFACE
5 PSF STAY IN PLACE FORMS

DESIGN: AASHTO LRFD BRIDGE DESIGN SPECIFICATIONS 8TH EDITION

ANSI/AASHTO/AWS D1.5 BRIDGE WELDING CODE
ANSI/AWS D1.6 STRUCTURAL WELDING CODE - STAINLESS STEEL

LRFR OPERATING RATING = XXX

INDEX OF SHEETS

B022 - B023	GENERAL PLAN AND ELEVATION
B024	SUPERSTRUCTURE DETAILS

FOUNDATION DATA

ABUTMENTS (HP XX X XX PILING)

FACTORED PILE REACTION (TONS/PILE) = XX.X

ALL ABUTMENT PILING SHALL BE DRIVEN THROUGH THE COMPACTED FILL. PILING SHALL BE DRIVEN TO POINT BEARING ON SOLID FOUNDATION MATERIAL AT THE APPROXIMATE ELEVATION SHOWN ON THE PLANS.

IF THE AXIAL LOAD RESISTANCE IS NOT OBTAINED AT THIS ELEVATION, DRIVING SHALL CONTINUE UNTIL THE AXIAL LOAD RESISTANCE IS OBTAINED. THE LENGTH OF STEEL PILING SHOWN ON THE PLANS IS FOR ESTIMATING PURPOSES ONLY.

PIERS (XX" DIAMETER DRILLED SHAFTS)

FACTORED REACTION (TONS/SHAFT) = XX.X

NOMINAL UNIT BEARING RESISTANCE (TSF) = XX.X

BEARING RESISTANCE FACTOR = XX.X

FACTORED BEARING RESISTANCE (TON/SHAFT) = XX.X

NOMINAL UNIT FRICTION RESISTANCE (TSF) = XX.X

FRICTION RESISTANCE FACTOR = XX.X

FACTORED FRICTION RESISTANCE (TON/SHAFT) = XX.X

FRICTION DEPTH OF ROCK NEGLECTED (FT) = XX.X

MINIMUM DEPTH INTO FOUNDATION MATERIAL (FT) = XX.X

TOTAL FACTORED RESISTANCE (TONS/SHAFT) = XX.X

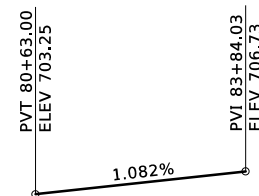

VERTICAL PROFILE DATA - CRL RAMP E2

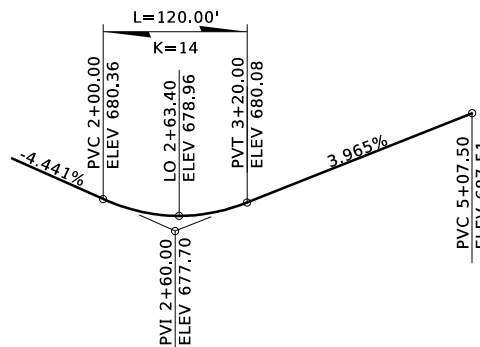

VERTICAL PROFILE DATA - 49th STREET

ITEMIZED QUANTITIES

ITEM	UNIT	ABUTMENT	PIER	SUPER-STRUCTURE	APPROACH SLAB	SLOPEWALL	TOTAL

BRIDGE J3, I-44 & US-75		TULSA COUNTY	
RAMP E2 OVER W. 49th ST.		Design	KSJ 4/20
GENERAL PLAN AND ELEVATION (SHEET 2 OF 2)		Detail	TBG 6/20
		Check	SOT 8/20
CONSTRUCT 50'-63'-50' TYPE III P.C. BEAM SPANS, 5 DEG. SKEW LF, 29'-0" CLEAR ROADWAY W/F-SHP PARAPETS, C.L. STA. 82+84.20 RAMP E2			
STATE OF OKLAHOMA	DEPARTMENT OF TRANSPORTATION		BENHAM
JOB PIECE NO. 33788(11)		SHEET NO. B023	

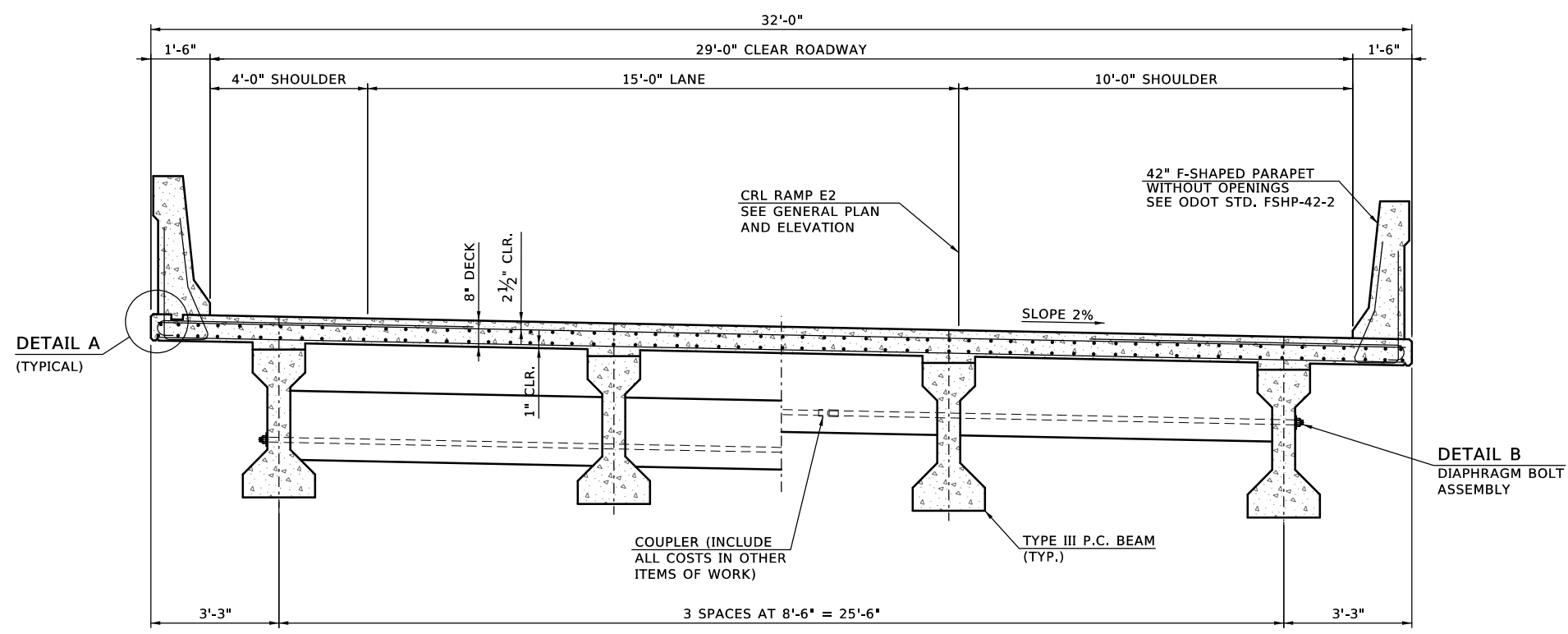

HALF SECTION AT INTERMEDIATE DIAPHRAGM

TYPICAL SECTION

HALF SECTION AT END DIAPHRAGM

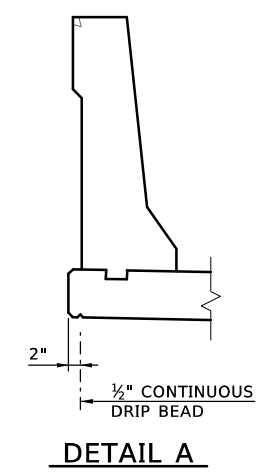

DETAIL A

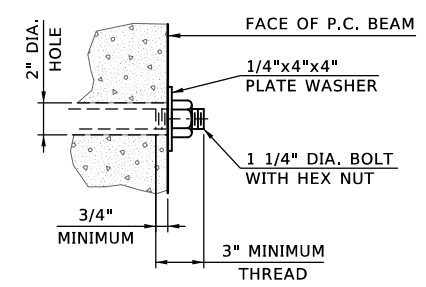

DIAPHRAGM BOLT NOTES

PROVIDE STRUCTURAL STEEL FOR DIAPHRAGM BOLTS AND PLATE WASHERS IN ACCORDANCE WITH AASHTO M270 (ASTM A709), GRADE 50W (WEATHERING STEEL, CHARPY V-NOTCH TESTING NOT REQUIRED). THE CONTRACTOR MAY SUBSTITUTE A #10 REINFORCING BAR IN ACCORDANCE WITH AASHTO M31, GRADE 60, AND THREADED AT THE ENDS AS SHOWN FOR THE DIAPHRAGM BOLT AT NO ADDITIONAL COST TO THE DEPARTMENT. PROVIDE HEX NUTS IN ACCORDANCE WITH AASHTO M291 (ASTM A563). PAINT EXPOSED DIAPHRAGM BOLT, PLATE WASHER AND HEX NUT WITH TWO (2) COATS OF ZINC-RICH PAINT (6 MIL MINIMUM THICKNESS) AFTER ASSEMBLY. INCLUDE ALL COST OF DIAPHRAGM BOLT, PLATE WASHER AND HEX NUT IN THE CONTRACT PRICE FOR "STRUCTURAL STEEL M270 GRADE 50W".

DETAIL B

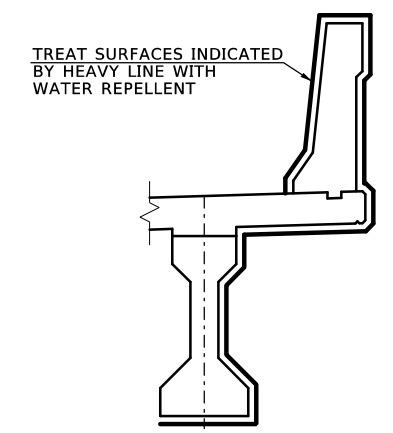

WATER REPELLENT TREATMENT DETAIL

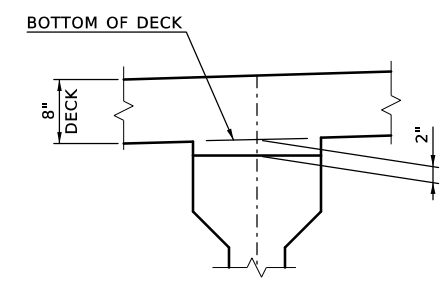

P.C. BEAM TYPE III HAUNCH DETAIL

NOTE:
 PLAN QUANTITIES FOR CLASS AA CONCRETE INCLUDE BEAM HAUNCHES. THE HAUNCH HEIGHT SHOWN IS THE THEORETICAL HAUNCH HEIGHT AT THE CENTERLINE BEARING ONLY, MEASURED FROM THE BOTTOM OF THE DECK SLAB TO THE TOP OF THE BEAM, AND VARIES ACROSS THE SPAN. DETERMINE THE ACTUAL HAUNCH HEIGHT (ACCOUNTING FOR BEAM CAMBER, DEAD LOAD DEFLECTION AND ROADWAY GRADE) AFTER ERECTION OF THE BEAMS AND SUBMIT TO THE ENGINEER FOR APPROVAL. THE ENGINEER WILL NOT MEASURE DIFFERENCES BETWEEN THE THEORETICAL AND THE ACTUAL HAUNCH HEIGHTS FOR PAYMENT.

BRIDGE J3, I-44 & US-75 RAMP E2 OVER W. 49th ST.	TULSA COUNTY	Design	KSJ	4/20
SUPERSTRUCTURE DETAILS		Detail	TBG	6/20
		Check	SOT	8/20
STATE OF OKLAHOMA		DEPARTMENT OF TRANSPORTATION		JOB PIECE NO. 33788(11)
				SHEET NO. B024

P:\FDB\650-TUL\CIV\400315_0DOT_EC2123A_US75\Design-Working\STRC\Microstation\337881\WPS\Sheets\Bridges\J3\337881\ST TYPICAL SECTION.dgn 3/4/2021

R/W UTILITY MEETING
MARCH 2021

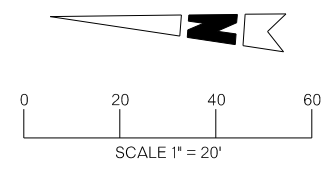

BENCHMARK 127A
CUT X ON HEADWALL
STA. 117+97.08, 130.61' RT CLS I-44
STA. 281+96.89, 130.55' RT CRL I-44
N 402277.28, E 2557167.48, EL. 647.773

BENCHMARK 127B
CUT X ON WEST ENDHEADWALL
STA. 119+15.21, 121.49' RT CLS I-44
STA. 283+15.01, 121.43' RT CRL I-44
N 402288.26, E 2557285.45, EL. 645.844

BENCHMARK 127C
CUT X ON CL HEADWALL
STA. 119+25.36, 155.62' RT CLS I-44
STA. 283+25.17, 155.56' RT CRL I-44
N 402254.29, E 2557296.14, EL. 645.458

BENCHMARK 127D
CUT X ON HEADWALL
STA. 121+96.90, 103.87' RT CLS I-44
STA. 285+96.71, 103.79' RT CRL I-44
N 402310.30, E 2557566.83, EL. 649.568

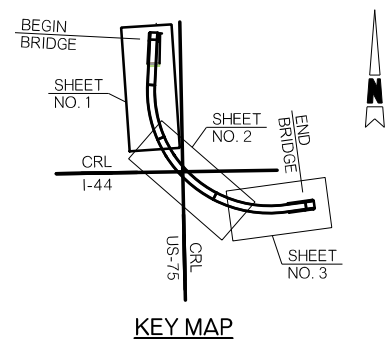

- ① PROPOSED MIN. VERTICAL CLEARANCE 39'-1" PGL RAMP E3 STA. 78+96.65, 19'-3" LT.
- ② PROPOSED MIN. VERTICAL CLEARANCE 17'-5" CRL RAMP E3 STA. 80+14.95, 19'-3" LT.
- ③ CONSTRUCTED IN WORK PACKAGE JP 33788(04).
- ④ CONSTRUCTED IN WORK PACKAGE JP 33788(08).

NOTES:
FOR DESIGN DATA, VERTICAL PROFILE DATA, AND FOUNDATION DATA SEE SHEET NO. B028.

BRIDGE L, I-44 & US-75 RAMP E3	TULSA COUNTY	Design	DS	4/20
GENERAL PLAN AND ELEVATION (SHEET 1 OF 4)		Detail	TBG	6/20
		Check	SOT	8/20
CONSTRUCT 95'-94'-115'-170'-171'-120'-153'-120' P.C. BEAM AND STEEL GIRDER SPAN, 29'-0" CLEAR ROADWAY W/F-SHP PARAPETS, C.L. STA. 83+63.61				
STATE OF OKLAHOMA	DEPARTMENT OF TRANSPORTATION			

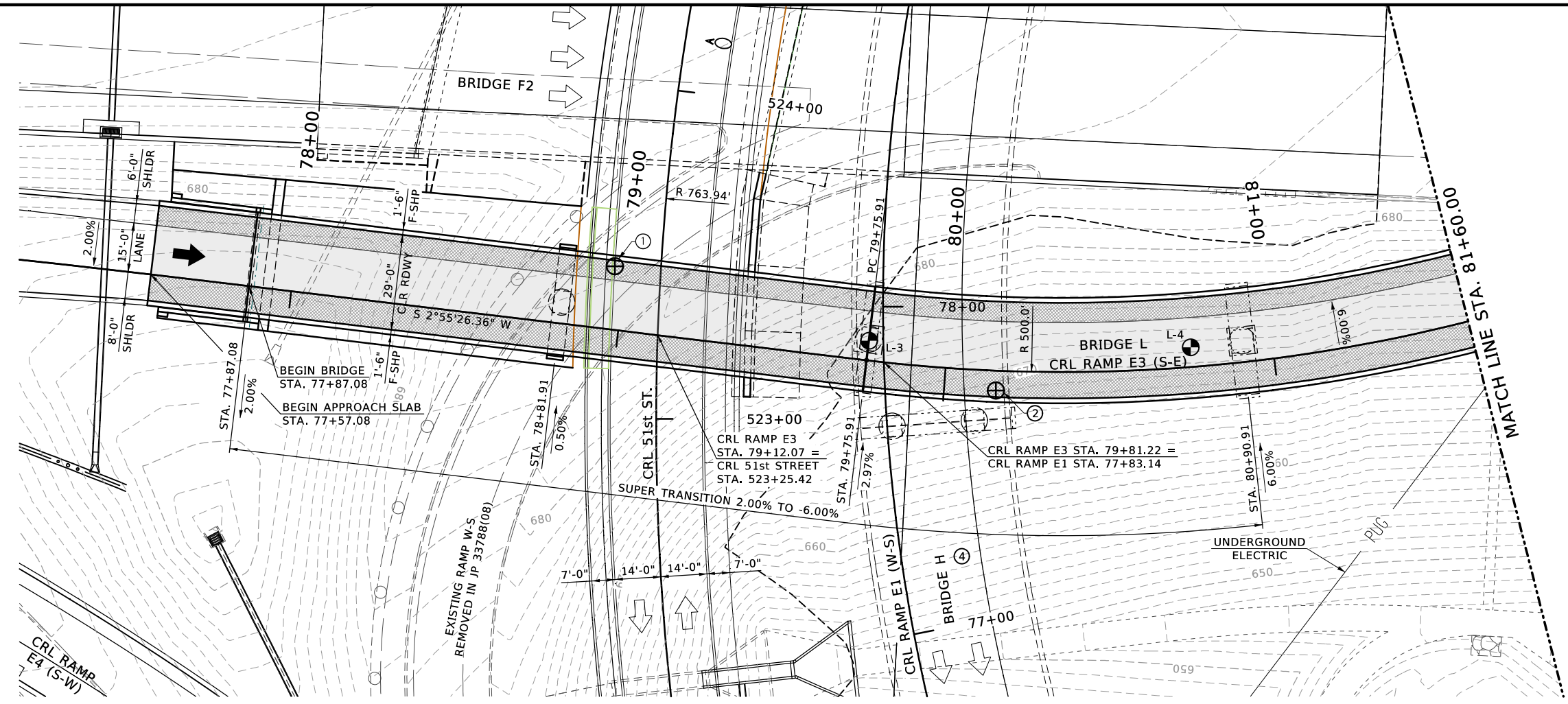

PLAN

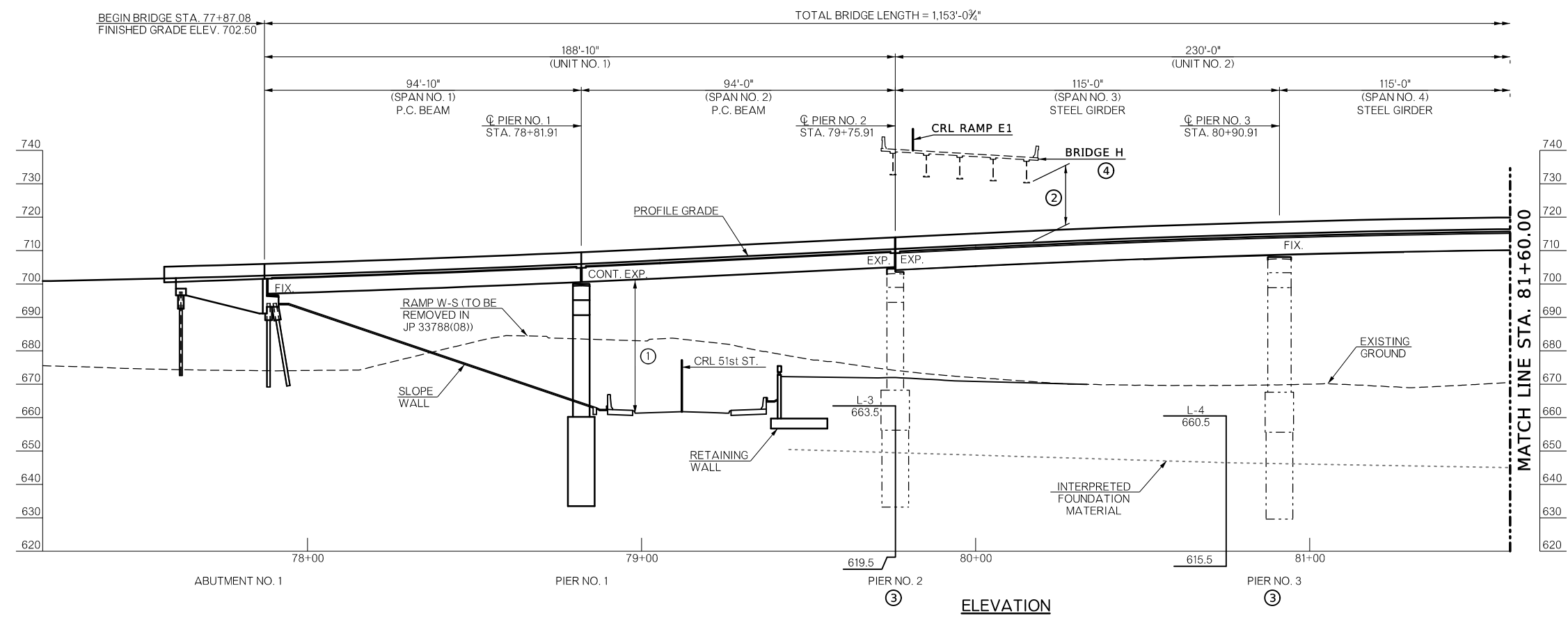

ELEVATION

3/4/2021
 P:\FDB\650-TUL\CIV\400315_0DOT_EC2123A_US75\Design-Working\STRC\Microstation\33788\WP5\Sheets\Bridg L\33788(1)S8 GENERAL PLAN AND ELEVATION 01.dgn

R/W UTILITY MEETING

MARCH 2021

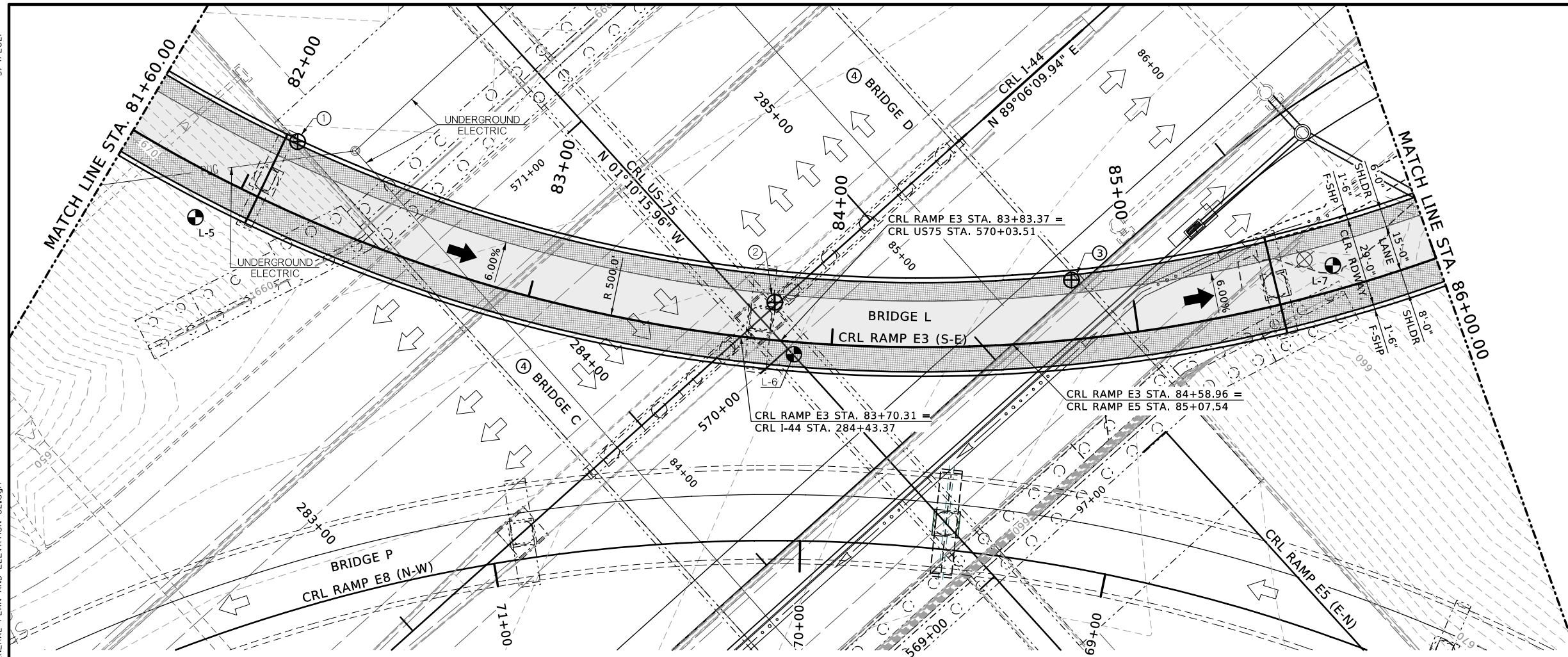
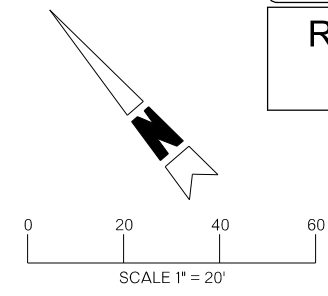

PLAN

BENCHMARK 127A
 CUT X ON HEADWALL
 STA. 117+97.08, 130.61' RT CLS I-44
 STA. 281+96.89, 130.55' RT CRL I-44
 N 402277.28, E 2557167.48, EL. 647.773

BENCHMARK 127B
 CUT X ON WEST END HEADWALL
 STA. 119+15.21, 121.49' RT CLS I-44
 STA. 283+15.01, 121.43' RT CRL I-44
 N 402288.26, E 2557285.45, EL. 645.844

BENCHMARK 127C
 CUT X ON CL HEADWALL
 STA. 119+25.36, 155.62' RT CLS I-44
 STA. 283+25.17, 155.56' RT CRL I-44
 N 402254.29, E 2557296.14, EL. 645.458

BENCHMARK 127D
 CUT X ON HEADWALL
 STA. 121+96.90, 103.87' RT CLS I-44
 STA. 285+96.71, 103.79' RT CRL I-44
 N 402310.30, E 2557566.83, EL. 649.568

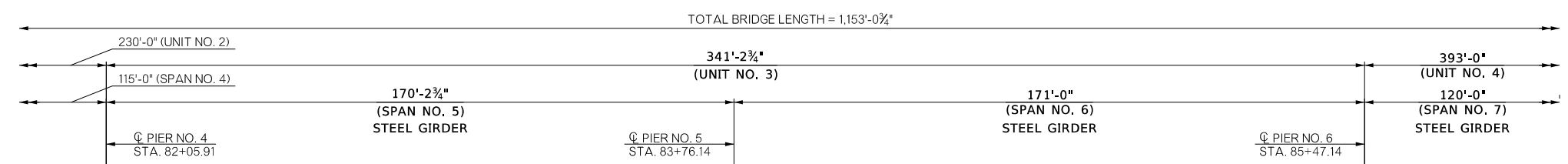

ELEVATION

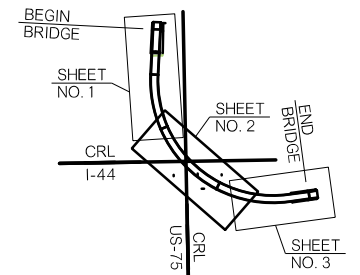

KEY MAP

- ① PROPOSED MIN. VERTICAL CLEARANCE 22'-2" CRL RAMP E3 STA. 82+08.53 OFFSET 22'-4" LT. BOTTOM OF PIER ELEV. 703.10
- ② PROPOSED MIN. VERTICAL CLEARANCE 17'-3" CRL RAMP E3 STA. 83+79.73 OFFSET 12'-9" LT. BOTTOM OF PIER ELEV. 695.86
- ③ PROPOSED MIN. VERTICAL CLEARANCE 22'-4" CRL RAMP E3 STA. 84+82.25 OFFSET 19'-3" LT.
- ④ CONSTRUCTED IN WORK PACKAGE JP 33788(04).

NOTES:
 FOR DESIGN DATA, VERTICAL PROFILE DATA, AND FOUNDATION DATA SEE SHEET NO. B028.

BRIDGE L, I-44 & US-75		TULSA COUNTY	
RAMP E3		Design DS 4/20	
GENERAL PLAN AND ELEVATION (SHEET 2 OF 4)		Detail TBG 6/20	
CONSTRUCT 95'-94"-115'-170'-171'-120'-153'-120' P.C. BEAM AND STEEL GIRDER SPAN, 29'-0" CLEAR ROADWAY W/F-SHP PARAPETS, C.L. STA. 83+63.61		Check SOT 8/20	
STATE OF OKLAHOMA		DEPARTMENT OF TRANSPORTATION	
JOB PIECE NO. 33788(11)		SHEET NO. B026	

3/4/2021
 P:\FDB\650-TUL\CV\1400315.0DOT_EC2123A_US75\Design-Work\King\STRC\Microstation\337881\58 GENERAL PLAN AND ELEVATION 02.dgn

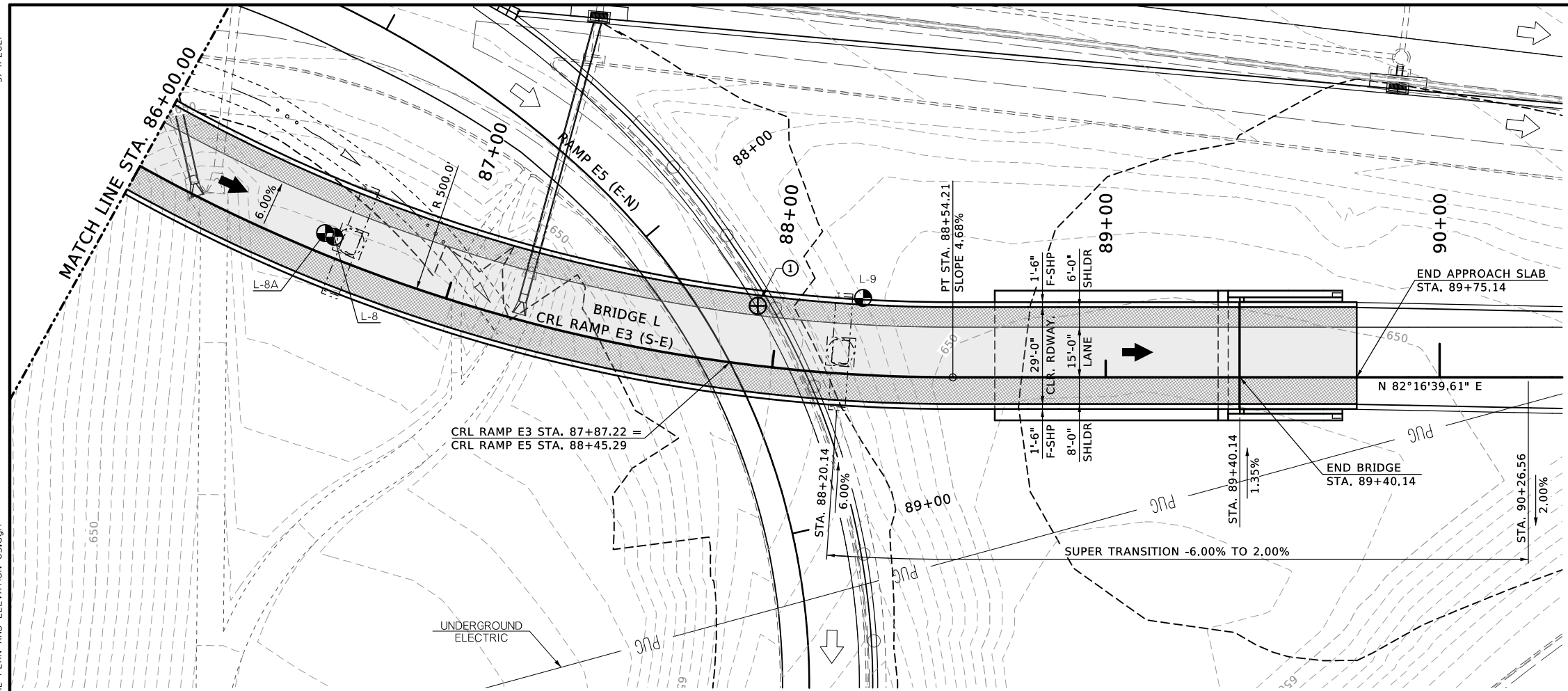
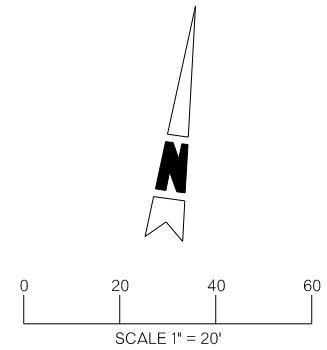

PLAN

BENCHMARK 127A
CUT X ON HEADWALL
STA. 117+97.08, 130.61' RT CLS I-44
STA. 281+96.89, 130.55' RT CRL I-44
N 402277.28, E 2557167.48, EL. 647.773

BENCHMARK 127B
CUT X ON WEST ENDHEADWALL
STA. 119+15.21, 121.49' RT CLS I-44
STA. 283+15.01, 121.43' RT CRL I-44
N 402288.26, E 2557285.45, EL. 645.844

BENCHMARK 127C
CUT X ON CL HEADWALL
STA. 119+25.36, 155.62' RT CLS I-44
STA. 283+25.17, 155.56' RT CRL I-44
N 402254.29, E 2557296.14, EL. 645.458

BENCHMARK 127D
CUT X ON HEADWALL
STA. 121+96.90, 103.87' RT CLS I-44
STA. 285+96.71, 103.79' RT CRL I-44
N 402310.30, E 2557566.83, EL. 649.568

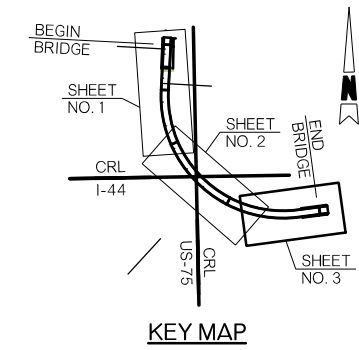

KEY MAP

- ① PROPOSED MIN. VERTICAL CLEARANCE 24'-9" CRL RAMP E3 STA. 88+10.85 OFFSET 6'-3" RT.
- ② CONSTRUCTED IN WORK PACKAGE JP 33788(04).

NOTES:
FOR DESIGN DATA, VERTICAL PROFILE DATA, AND FOUNDATION DATA SEE SHEET NO. B028.

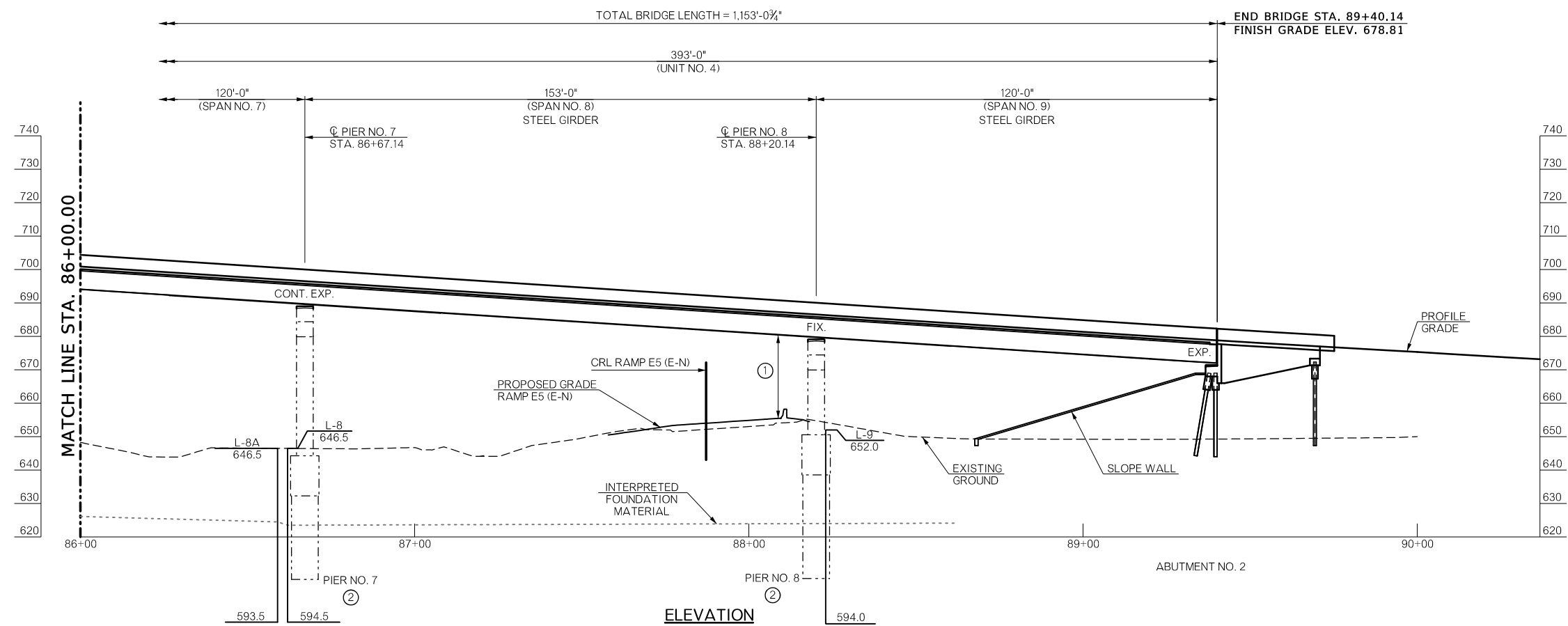

ELEVATION

BRIDGE I, I-44 & US-75		TULSA COUNTY		Design	DS	4/20
RAMP E3				Detail	TBG	6/20
GENERAL PLAN AND ELEVATION (SHEET 3 OF 4)				Check	SOT	8/20
CONSTRUCT 95'-94'-115'-170'-171'-120'-153'-120' P.C. BEAM AND STEEL GIRDER SPAN, 29'-0" CLEAR ROADWAY W/ F-SHP PARAPETS, C.L. STA. 83+63.61						
STATE OF OKLAHOMA		DEPARTMENT OF TRANSPORTATION			JOB PIECE NO. 33788(11)	
					SHEET NO. B027	

3/4/2021
P:\FDB\650-TUL\CIV\400315.0DOT_EC2123A_US75\Design-Working\STRC\Microstation\33788\WP5\Sheets\Bridges\33788\58 GENERAL PLAN AND ELEVATION 03.dgn

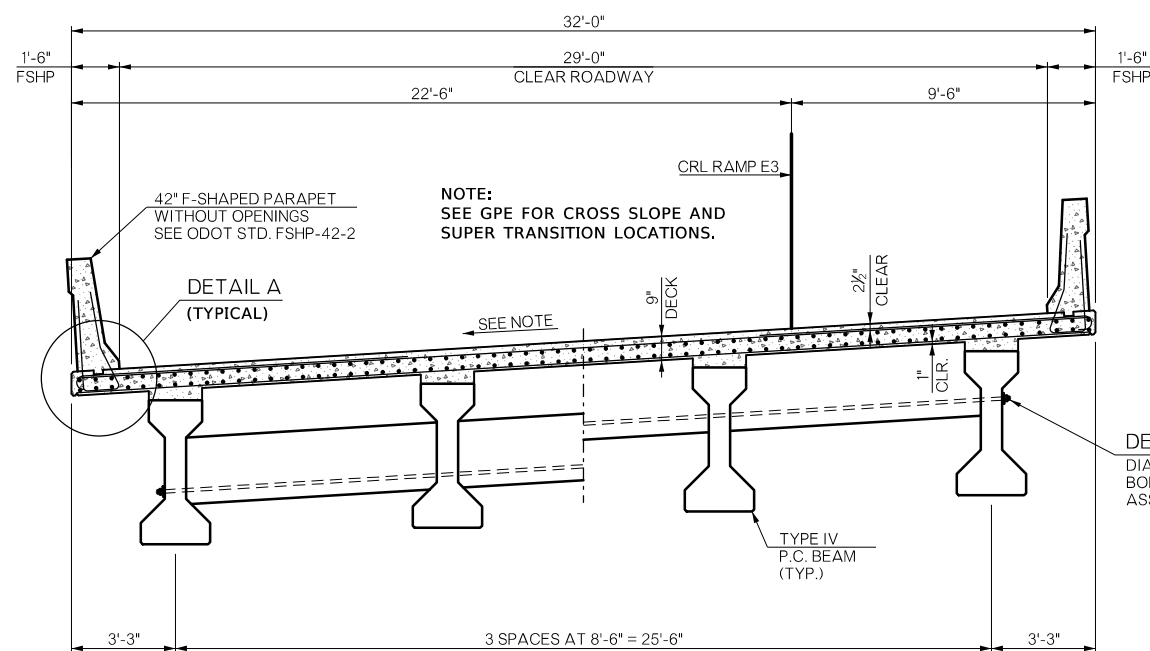

HALF SECTION AT INTERMEDIATE DIAPHRAGM TYPICAL SECTION SPAN NOS. 1 - 2 HALF SECTION AT END DIAPHRAGM

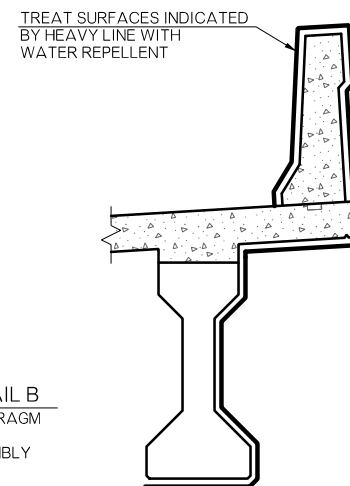

WATER REPELLENT TREATMENT DETAIL

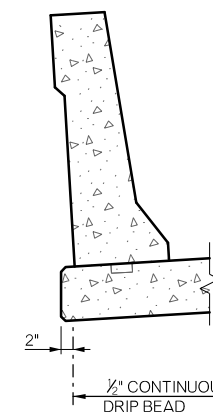

DETAIL A

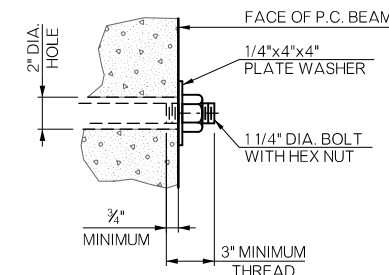

DETAIL B

DIAPHRAGM BOLT NOTES

PROVIDE STRUCTURAL STEEL FOR DIAPHRAGM BOLTS AND PLATE WASHERS IN ACCORDANCE WITH AASHTO M270 (ASTM A709), GRADE 50W (WEATHERING STEEL, CHARPY V-NOTCH TESTING NOT REQUIRED). THE CONTRACTOR MAY SUBSTITUTE A #10 REINFORCING BAR IN ACCORDANCE WITH AASHTO M31, GRADE 60, AND THREADED AT THE ENDS AS SHOWN FOR THE DIAPHRAGM BOLT AT NO ADDITIONAL COST TO THE DEPARTMENT. PROVIDE HEX NUTS IN ACCORDANCE WITH AASHTO M291 (ASTM A563). PAINT EXPOSED DIAPHRAGM BOLT, PLATE WASHER AND HEX NUT WITH TWO (2) COATS OF ZINC-RICH PAINT (6 MIL MINIMUM THICKNESS) AFTER ASSEMBLY. INCLUDE ALL COST OF DIAPHRAGM BOLT, PLATE WASHER AND HEX NUT IN THE CONTRACT PRICE FOR "STRUCTURAL STEEL M270 GRADE 50W".

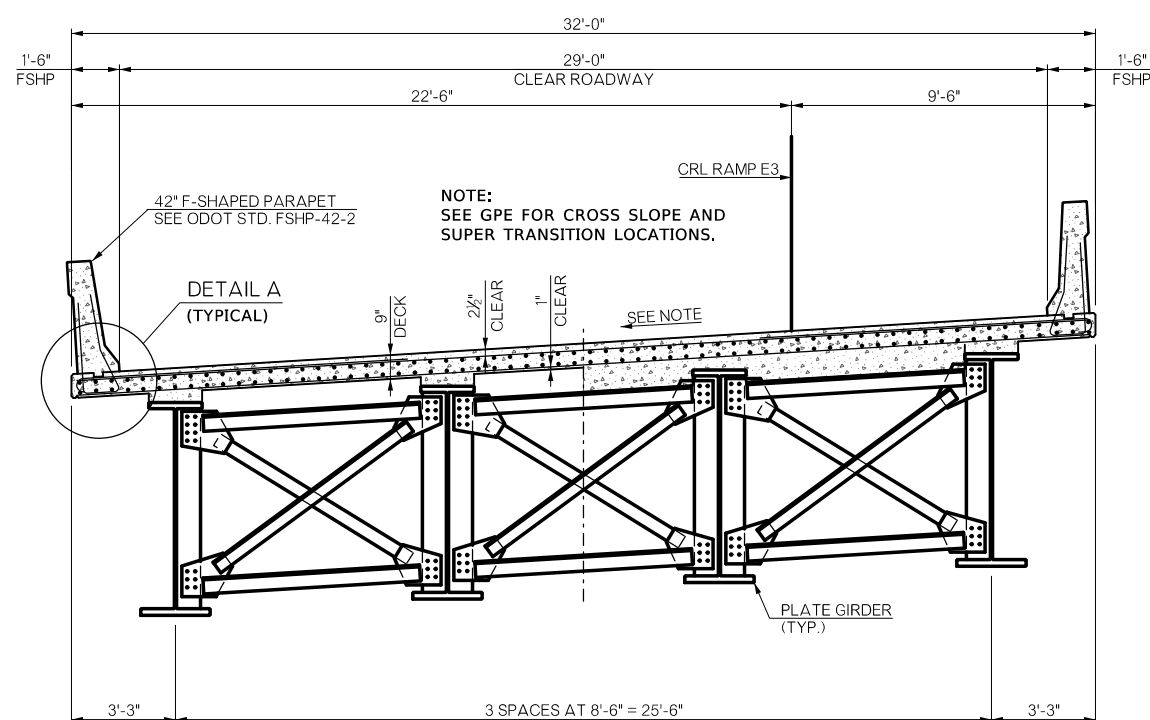

HALF SECTION AT INTERMEDIATE DIAPHRAGM TYPICAL SECTION SPAN NOS. 3 - 9 HALF SECTION AT END DIAPHRAGM

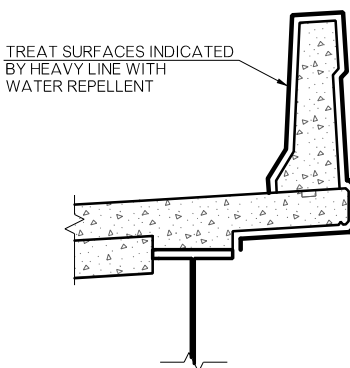

WATER REPELLENT TREATMENT DETAIL

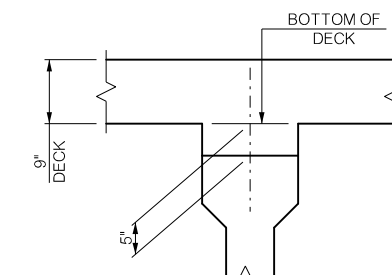

BEAM HAUNCH DETAIL (TYPE IV)

NOTE:

PLAN QUANTITIES FOR CLASS AA CONCRETE INCLUDE BEAM HAUNCHES. THE HAUNCH HEIGHT SHOWN IS THE THEORETICAL HAUNCH HEIGHT AT THE CENTERLINE BEARING ONLY, MEASURED FROM THE BOTTOM OF THE DECK SLAB TO THE TOP OF THE BEAM, AND VARIES ACROSS THE SPAN. DETERMINE THE ACTUAL HAUNCH HEIGHT (ACCOUNTING FOR BEAM CAMBER, DEAD LOAD DEFLECTION AND ROADWAY GRADE) AFTER ERECTION OF THE BEAMS AND SUBMIT TO THE ENGINEER FOR APPROVAL. THE ENGINEER WILL NOT MEASURE DIFFERENCES BETWEEN THE THEORETICAL AND THE ACTUAL HAUNCH HEIGHTS FOR PAYMENT.

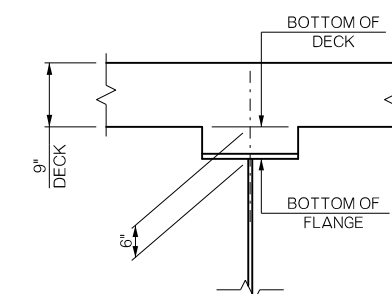

BEAM HAUNCH DETAIL (PLATE GIRDER)

NOTE:

PLAN QUANTITIES FOR CLASS AA CONCRETE INCLUDE BEAM HAUNCHES. THE HAUNCH HEIGHT SHOWN IS THE THEORETICAL HAUNCH HEIGHT AT THE CENTERLINE BEARING ONLY, MEASURED FROM THE BOTTOM OF THE DECK SLAB TO THE TOP OF THE WEB, AND VARIES ACROSS THE SPAN. DETERMINE THE ACTUAL HAUNCH HEIGHT (ACCOUNTING FOR BEAM CAMBER, DEAD LOAD DEFLECTION AND ROADWAY GRADE) AFTER ERECTION OF THE BEAMS AND SUBMIT TO THE ENGINEER FOR APPROVAL. THE ENGINEER WILL NOT MEASURE DIFFERENCES BETWEEN THE THEORETICAL AND THE ACTUAL HAUNCH HEIGHTS FOR PAYMENT.

BRIDGE L, I-44 & US-75 RAMP E3	TULSA COUNTY	Design	DS	4/20
SUPERSTRUCTURE DETAILS		Detail	TBG	6/20
		Check	SOT	8/20
STATE OF OKLAHOMA		DEPARTMENT OF TRANSPORTATION		JOB PIECE NO. 33788(11)
				SHEET NO. B029



R/W UTILITY MEETING

MARCH 2021

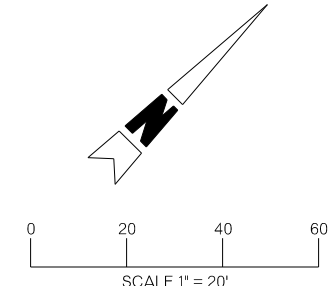

BENCHMARK 109
 CUT X IN CENTER OF CONC ISLAND
 STA. 270+45.33, 58.28' LT CLS US-75
 STA. 579+22.78, 58.44' LT CRL US-75
 N 403320.02, E 2557343.58, EL. 693.418

BENCHMARK 109A
 CUT X
 STA. 268+02.61, 63.73' LT CLS US-75
 STA. 576+80.06, 63.89' LT CRL US-75
 N 403077.23, E 2557343.09, EL. 684.871

BENCHMARK 110
 RR SPIKE S/E PP
 STA. 265+09.14, 585.09' LT CLS US-75
 STA. 573+86.59, 585.25' LT CRL US-75
 N 402773.16, E 2556827.84, EL. 673.94

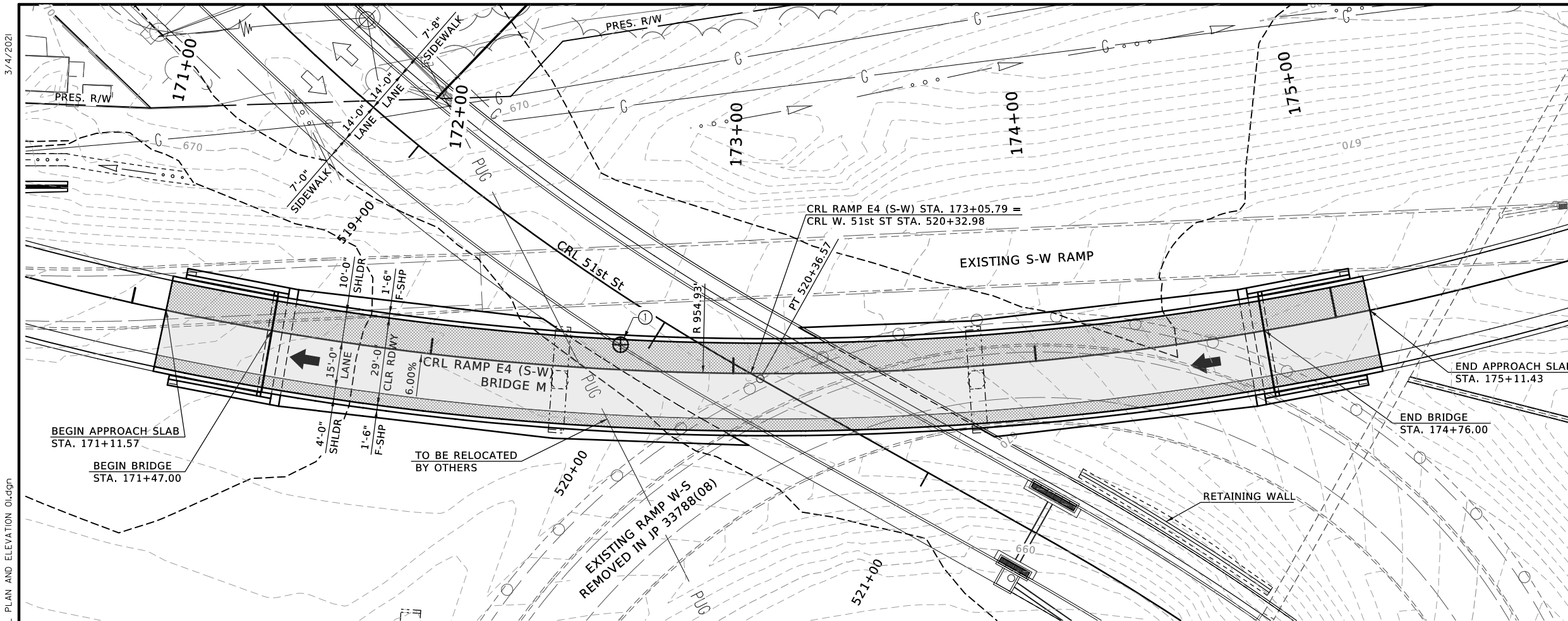

PLAN

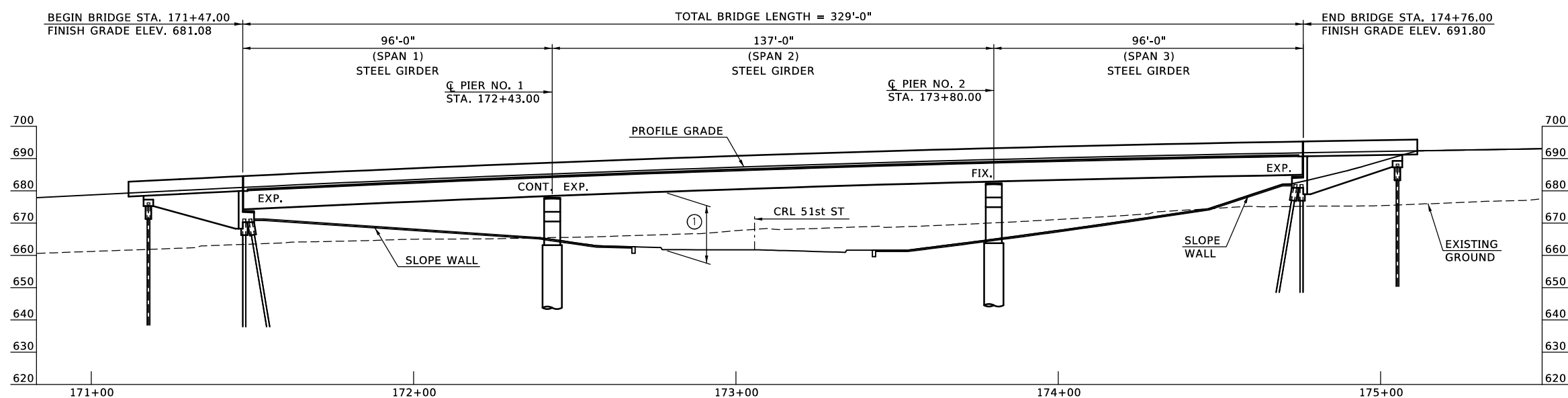

ELEVATION

NOTES:
 FOR DESIGN DATA, VERTICAL PROFILE DATA, AND
 FOUNDATION DATA SEE SHEET NO. B031.

① PROPOSED MIN. VERTICAL CLEARANCE 17'-2"
 CRL RAMP E4 (S-W) STA. 172+63.41
 OFFSET 8'-3" RT.

BRIDGE M, I-44 & US-75		TULSA COUNTY		Design	KSJ	4/20
RAMP E4				Detail	TBG	6/20
GENERAL PLAN AND ELEVATION				Check	SOT	8/20
(SHEET 1 OF 2)						
CONSTRUCT 96'-137'-96" STEEL GIRDER SPAN						
29'-0" CLEAR ROADWAY				STATE OF OKLAHOMA		
W/F-SHP PARAPETS, C.L. STA. 173+11.50		DEPARTMENT OF TRANSPORTATION		JOB PIECE NO. 33788(11)		
				SHEET NO. B030		

P:\FDB\650-TUL\CIV\400315.0DOT_EC2123A_US75\Design-Working\STRC\Microstation\33788\WP5\Sheets\Bridg M\33788\159 GENERAL PLAN AND ELEVATION 0.dgn 3/4/2021

3/4/2021

P:\FDB\650-TUL\CIV\400315-ODOT_EC2123A_US75\Design-Working\STRC\Microstation\337881\WP5\Sheets\Bridges\337881\WP5\TYPICAL_SECTION.dgn

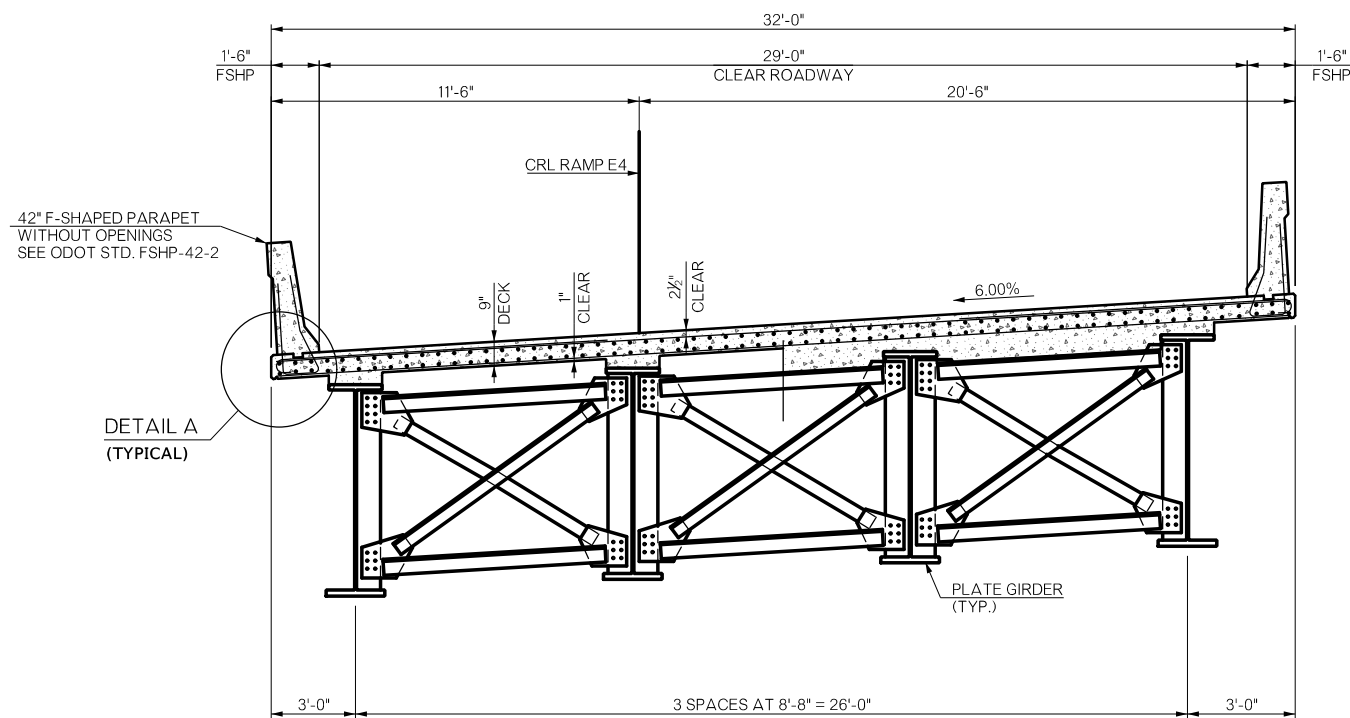

HALF SECTION AT INTERMEDIATE DIAPHRAGM

HALF SECTION AT END DIAPHRAGM

TYPICAL SECTION

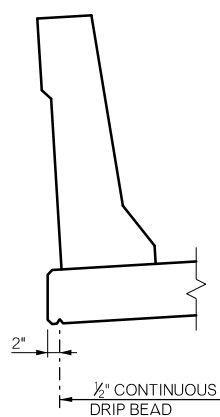

DETAIL A

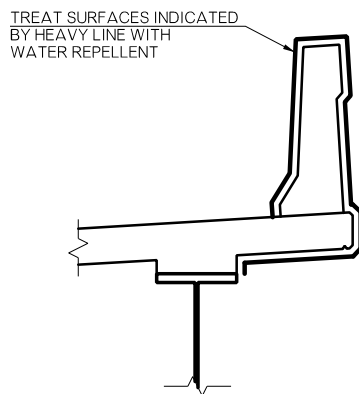

WATER REPELLENT TREATMENT DETAIL

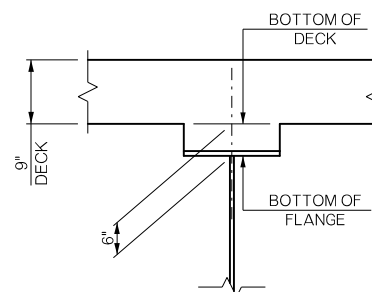

BEAM HAUNCH DETAIL (PLATE GIRDER)

NOTE:

PLAN QUANTITIES FOR CLASS AA CONCRETE INCLUDE BEAM HAUNCHES. THE HAUNCH HEIGHT SHOWN IS THE THEORETICAL HAUNCH HEIGHT AT THE CENTERLINE BEARING ONLY, MEASURED FROM THE BOTTOM OF THE DECK SLAB TO THE TOP OF THE WEB, AND VARIES ACROSS THE SPAN. DETERMINE THE ACTUAL HAUNCH HEIGHT (ACCOUNTING FOR BEAM CAMBER, DEAD LOAD DEFLECTION AND ROADWAY GRADE) AFTER ERECTION OF THE BEAMS AND SUBMIT TO THE ENGINEER FOR APPROVAL. THE ENGINEER WILL NOT MEASURE DIFFERENCES BETWEEN THE THEORETICAL AND THE ACTUAL HAUNCH HEIGHTS FOR PAYMENT.

BRIDGE M, I-44 & US-75 RAMP E4	TULSA COUNTY	Design	KSJ	4/20
SUPERSTRUCTURE DETAILS		Detail	TBG	6/20
		Check	SOT	8/20
STATE OF OKLAHOMA		DEPARTMENT OF TRANSPORTATION		JOB PIECE NO. 33788(11)
				SHEET NO. B032



R/W UTILITY MEETING

MARCH 2021

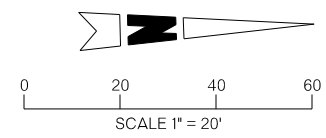

BENCHMARK 1B
 3/8IP
 STA. 107+68.14, 137.98' RT CLS I-44
 STA. 271+67.95, 137.97' RT CRL I-44
 N 402253.76, E 2556138.79, EL. 669.34

BENCHMARK 127A
 CUT X ON HEADWALL
 STA. 117+97.08, 130.61' RT CLS I-44
 STA. 281+96.89, 130.55' RT CRL I-44
 N 402277.28, E 2557167.48, EL. 647.773

BENCHMARK 127B
 CUT X ON WEST ENDHEADWALL
 STA. 119+15.21, 121.49' RT CLS I-44
 STA. 283+15.01, 121.43' RT CRL I-44
 N 402288.26, E 2557285.45, EL. 645.844

BENCHMARK 127C
 CUT X ON CL HEADWALL
 STA. 119+25.36, 155.62' RT CLS I-44
 STA. 283+25.17, 155.56' RT CRL I-44
 N 402254.29, E 2557296.14, EL. 645.458

BENCHMARK 127D
 CUT X ON HEADWALL
 STA. 121+96.90, 103.87' RT CLS I-44
 STA. 285+96.71, 103.79' RT CRL I-44
 N 402310.30, E 2557566.83, EL. 649.568

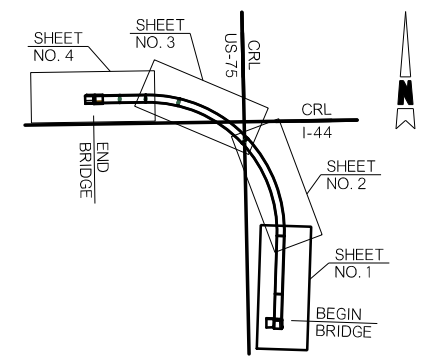

- ① CONSTRUCTED IN WORK PACKAGE JP 33788(04).
- ② CONSTRUCTED IN WORK PACKAGE JP 33788(09).

NOTES:
 FOR DESIGN DATA, HYDRAULIC DATA, VERTICAL PROFILE DATA,
 & FOUNDATION DATA SEE SHEET NO. B037.

BRIDGE P, I-44 & US-75		TULSA COUNTY	Design	DS	4/20
RAMP E8 OVER MOOSER CREEK			Detail	TBG	6/20
GENERAL PLAN AND ELEVATION			Check	SOT	8/20
(SHEET 1 OF 5)					
CONSTRUCT 109'-108'-135'-117'-146'-165'-136'-183'-136'-108'-109' P.C. BEAM AND STEEL GIRDER SPAN, 29'-0" CLEAR ROADWAY W/ F-SHP PARAPETS, C.L. STA. 68+99.42					
STATE OF OKLAHOMA		DEPARTMENT OF TRANSPORTATION		JOB PIECE NO. 33788(11)	
				SHEET NO. B033	

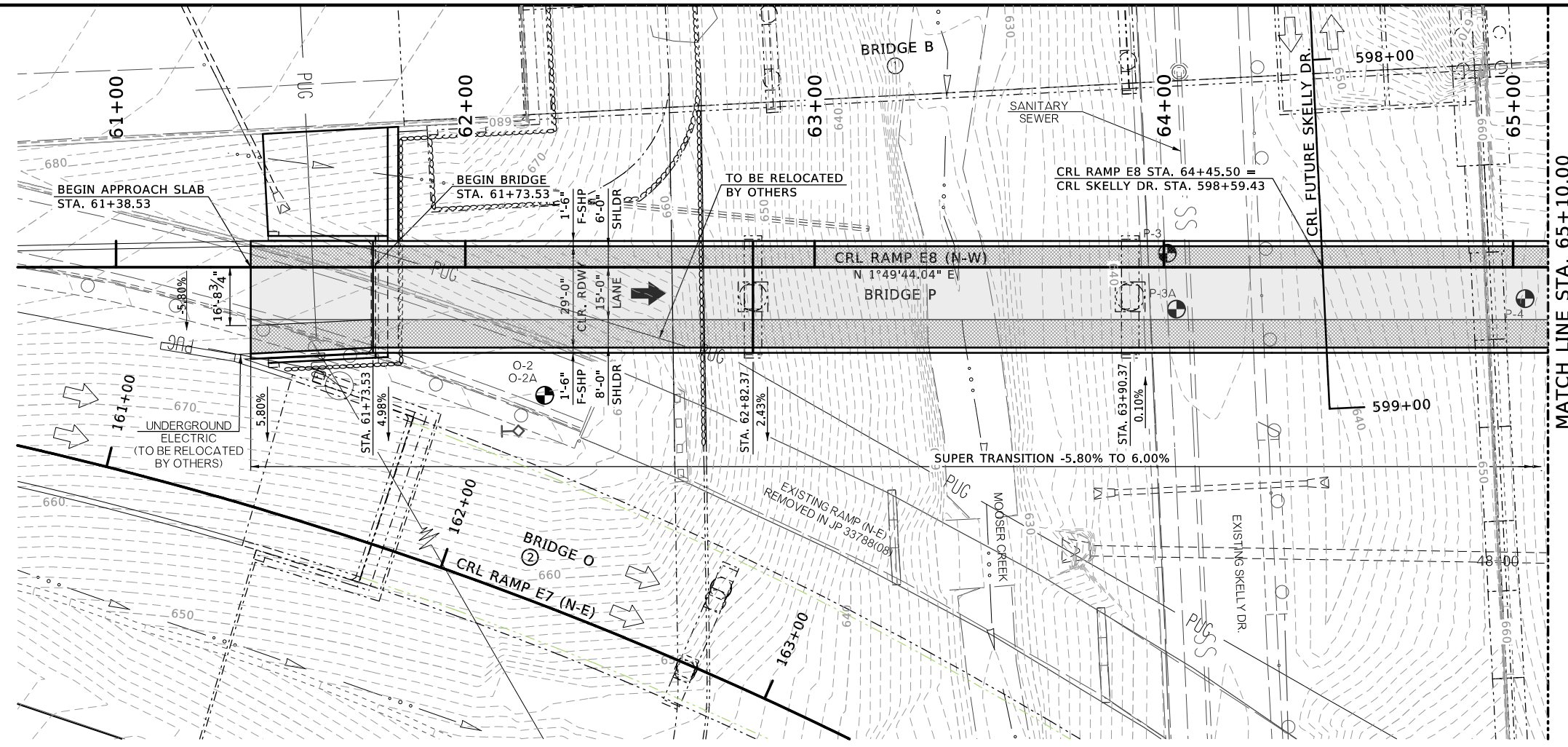

PLAN

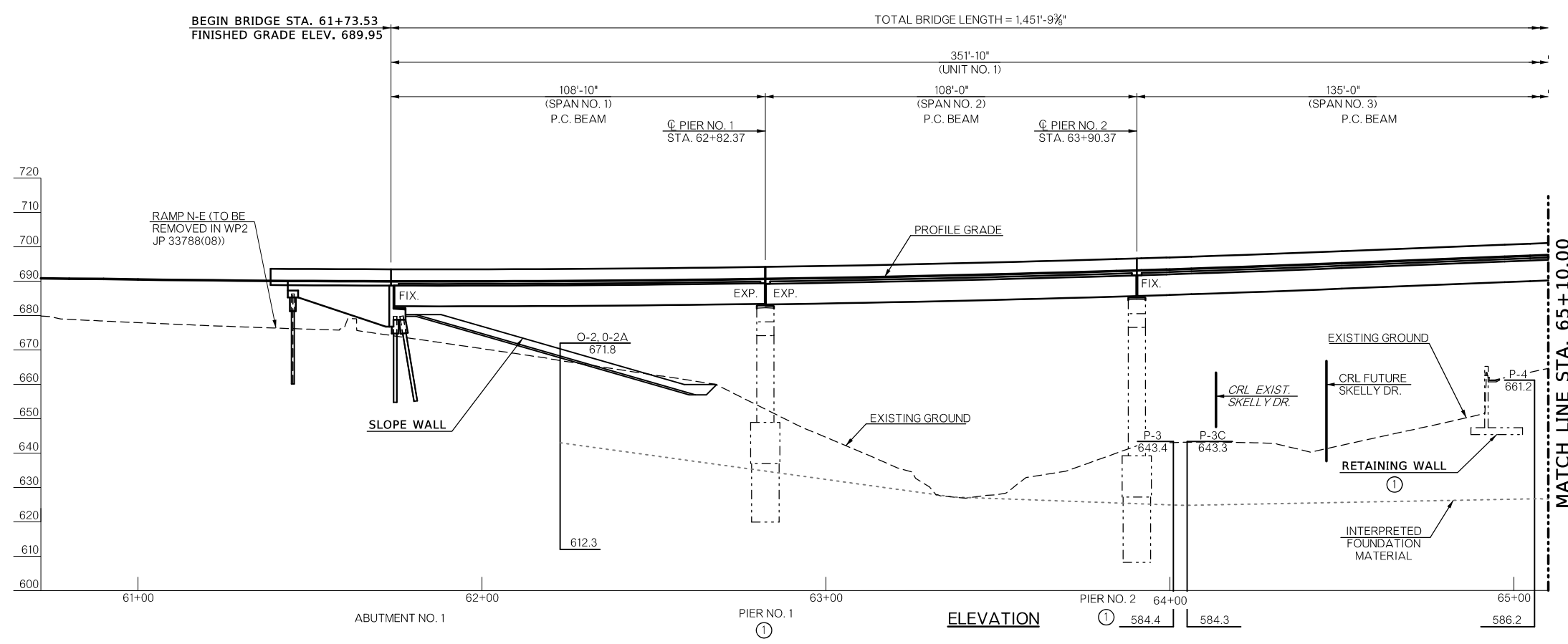

ELEVATION

3/4/2021
 P:\F0B\650-TUL\CV\400315_0DOT_EC2123A_US75\Design-Working\STRC\Microstation\33788\WP5\Sheets\Bridg P\33788\1-SIO GENERAL PLAN AND ELEVATION 01.dgn

R/W UTILITY MEETING

MARCH 2021

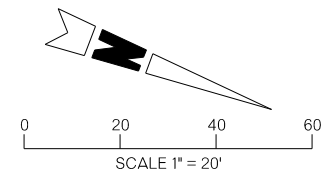

BENCHMARK 1B
3/8IP
STA. 107+68.14, 137.98' RT CLS I-44
STA. 271+67.95, 137.97' RT CRL I-44
N 402253.76, E 2556138.79, EL. 669.34

BENCHMARK 127A
CUT X ON HEADWALL
STA. 117+97.08, 130.61' RT CLS I-44
STA. 281+96.89, 130.55' RT CRL I-44
N 402277.28, E 2557167.48, EL. 647.773

BENCHMARK 127B
CUT X ON WEST ENDHEADWALL
STA. 119+15.21, 121.49' RT CLS I-44
STA. 283+15.01, 121.43' RT CRL I-44
N 402288.26, E 2557285.45, EL. 645.844

BENCHMARK 127C
CUT X ON CL HEADWALL
STA. 119+25.36, 155.62' RT CLS I-44
STA. 283+25.17, 155.56' RT CRL I-44
N 402254.29, E 2557296.14, EL. 645.458

BENCHMARK 127D
CUT X ON HEADWALL
STA. 121+96.90, 103.87' RT CLS I-44
STA. 285+96.71, 103.79' RT CRL I-44
N 402310.30, E 2557566.83, EL. 649.568

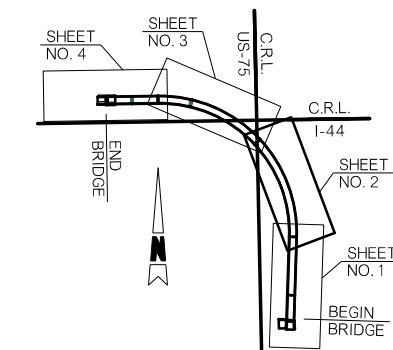

KEY MAP

- ① PROPOSED MIN. VERTICAL CLEARANCE 19'-4"
CRL RAMP E8 STA. 65+50.95, 4'-3" LT.
- ② PROPOSED MIN. VERTICAL CLEARANCE 17'-8"
CRL RAMP E8 STA. 69+56.76, 2'-3" LT.
- ③ CONSTRUCTED IN WORK PACKAGE JP 33788(04).

NOTES:
FOR DESIGN DATA, HYDRAULIC DATA, VERTICAL PROFILE DATA,
& FOUNDATION DATA SEE SHEET NO. B037.

BRIDGE P, I-44 & US-75		TULSA COUNTY	Design	DS	4/20
RAMP E8 OVER MOOSER CREEK			Detail	TBG	6/20
GENERAL PLAN AND ELEVATION			Check	SOT	8/20
(SHEET 2 OF 5)					
CONSTRUCT 109'-108'-135'-117'-146'-165'-136'-183'-136'-108'-109' P.C. BEAM AND STEEL GIRDER SPAN, 29'-0" CLEAR ROADWAY W/ F-SHP PARAPETS, C.L. STA. 68+99.42					
STATE OF OKLAHOMA		DEPARTMENT OF TRANSPORTATION		JOB PIECE NO. 33788(11)	
				SHEET NO. B034	

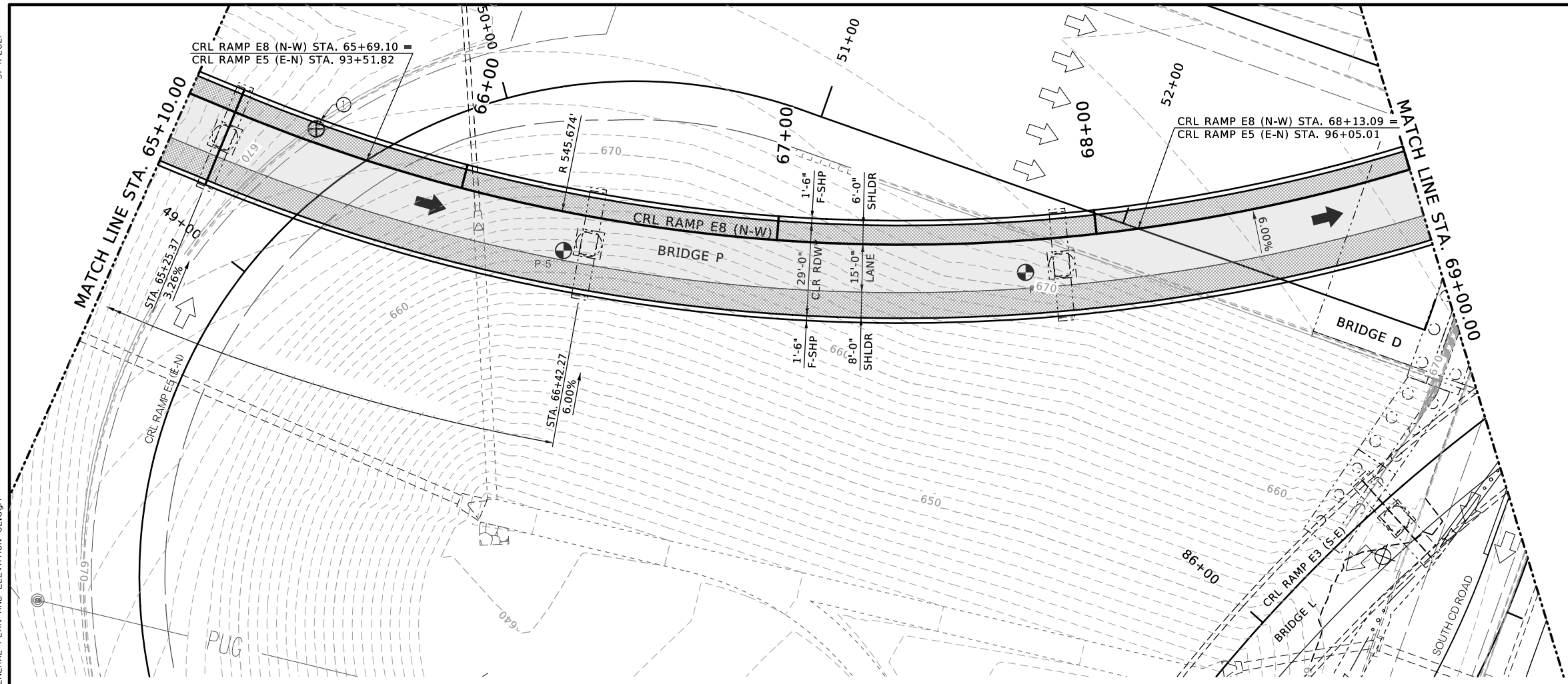

PLAN

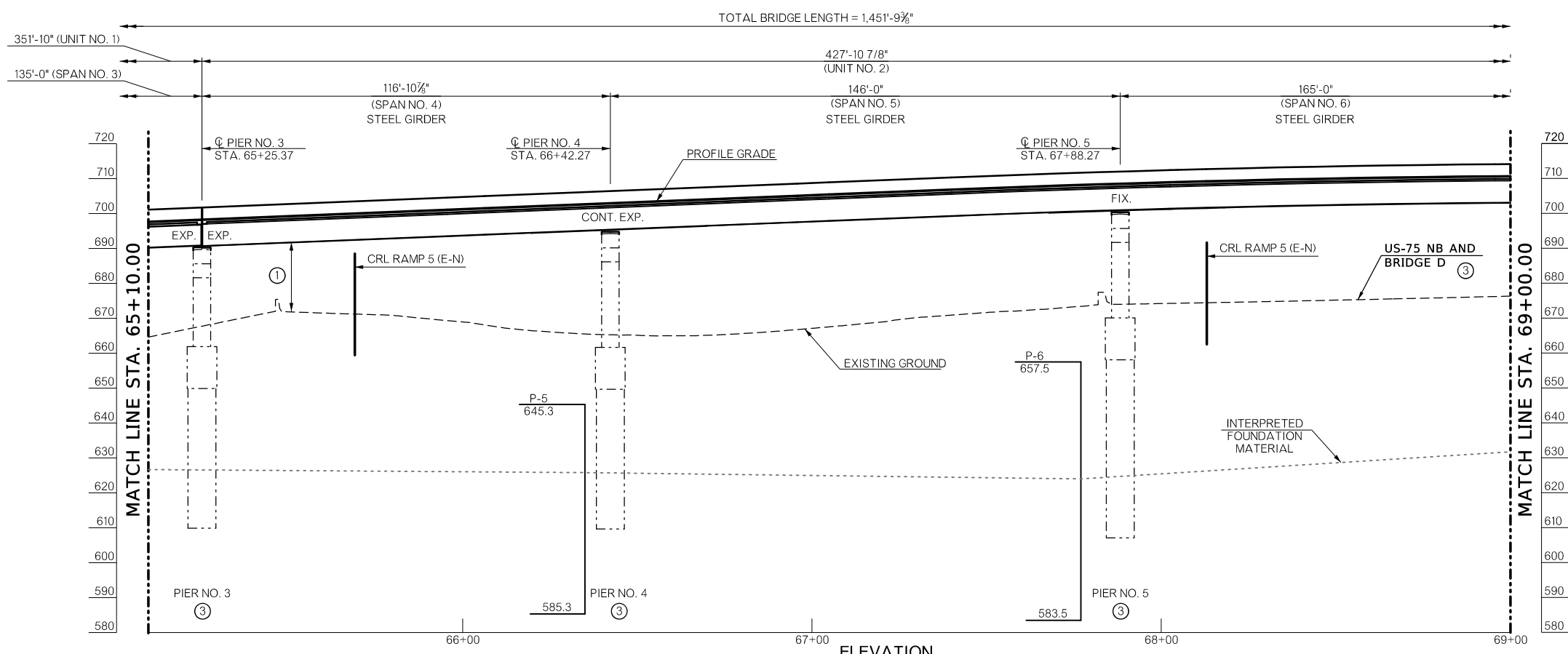

ELEVATION

3/4/2021
P:\FDB\650-TUL\CV\400315.0DOT_EC2123A_US75\Design-Working\STRC\Microstation\33788\WP5\Sheets\Bridg P\33788\1-SIO GENERAL PLAN AND ELEVATION 02.dgn

R/W UTILITY MEETING

MARCH 2021

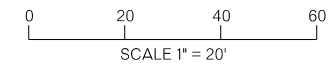
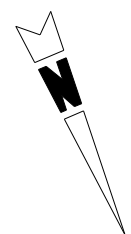

BENCHMARK 1B
 3/8IP
 STA. 107+68.14, 137.98' RT CLS I-44
 STA. 271+67.95, 137.97' RT CRL I-44
 N 402253.76, E 2556138.79, EL. 669.34

BENCHMARK 127A
 CUT X ON HEADWALL
 STA. 117+97.08, 130.61' RT CLS I-44
 STA. 281+96.89, 130.55' RT CRL I-44
 N 402277.28, E 2557167.48, EL. 647.773

BENCHMARK 127B
 CUT X ON WEST ENDHEADWALL
 STA. 119+15.21, 121.49' RT CLS I-44
 STA. 283+15.01, 121.43' RT CRL I-44
 N 402288.26, E 2557285.45, EL. 645.844

BENCHMARK 127C
 CUT X ON CL HEADWALL
 STA. 119+25.36, 155.62' RT CLS I-44
 STA. 283+25.17, 155.56' RT CRL I-44
 N 402254.29, E 2557296.14, EL. 645.458

BENCHMARK 127D
 CUT X ON HEADWALL
 STA. 121+96.90, 103.87' RT CLS I-44
 STA. 285+96.71, 103.79' RT CRL I-44
 N 402310.30, E 2557566.83, EL. 649.568

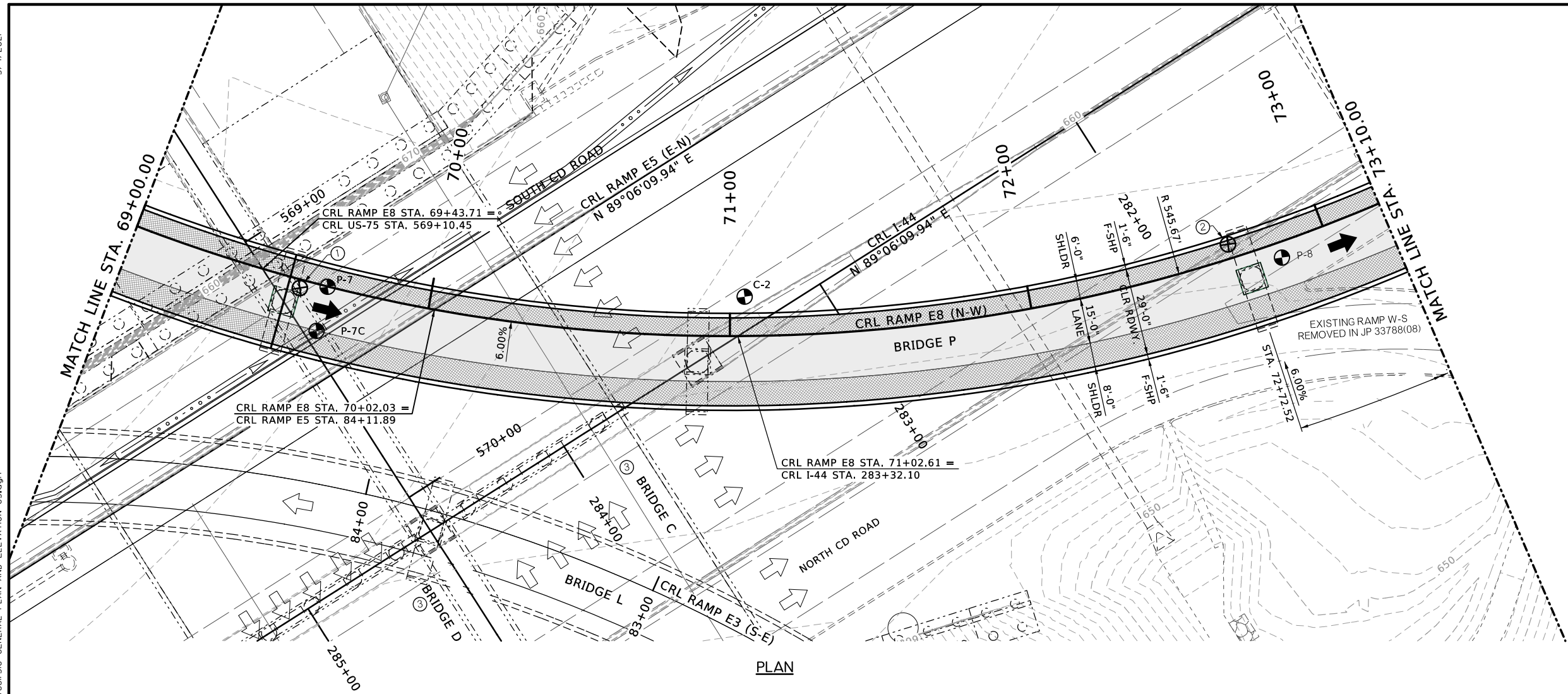

PLAN

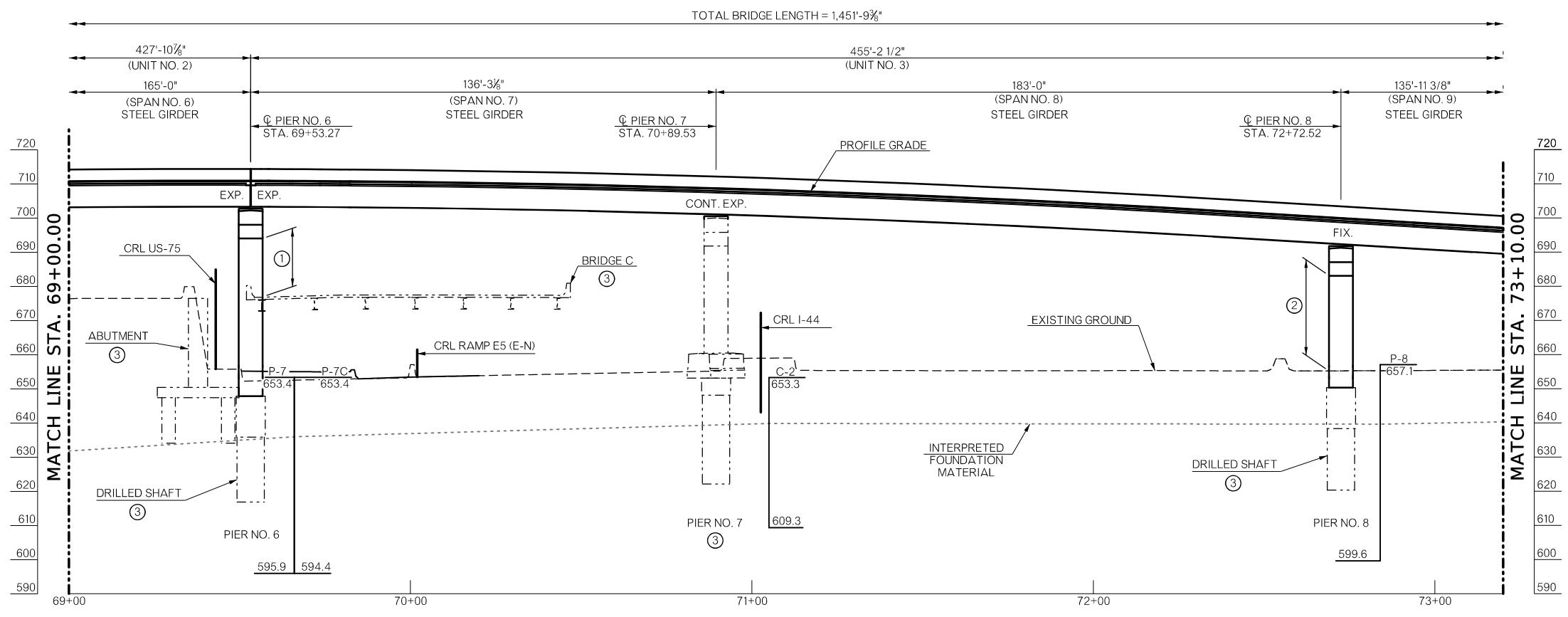

ELEVATION

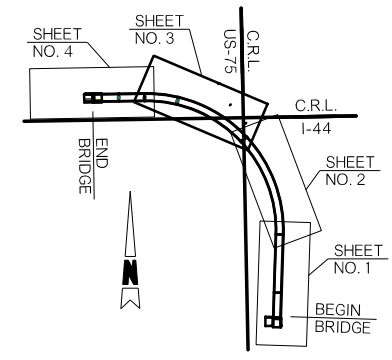

KEY MAP

- ① PROPOSED MIN. VERTICAL CLEARANCE 17'-8" CRL RAMP E8 STA. 69+56.76, 2'-3" LT.
- ② PROPOSED MIN. VERTICAL CLEARANCE 32'-1" CRL RAMP E8 STA. 72+68.99, 4'-11" LT.
- ③ CONSTRUCTED IN WORK PACKAGE JP 33788(04).

NOTES:
 FOR DESIGN DATA, HYDRAULIC DATA, VERTICAL PROFILE DATA,
 & FOUNDATION DATA SEE SHEET NO. B037.

BRIDGE P, I-44 & US-75		TULSA COUNTY	
RAMP E8 OVER MOOSER CREEK		Design DS 4/20	
GENERAL PLAN AND ELEVATION		Detail TBG 6/20	
(SHEET 3 OF 5)		Check SOT 8/20	
CONSTRUCT 109'-108'-135'-117'-146'-165'-136'-183'-136'-108'-109' P.C. BEAM AND STEEL GIRDER SPAN, 29'-0" CLEAR ROADWAY W/ F-SHP PARAPETS, C.L. STA. 68+99.42			
STATE OF OKLAHOMA		DEPARTMENT OF TRANSPORTATION	
JOB PIECE NO. 33788(11)		SHEET NO. B035	

3/4/2021
 P:\FDB\650-TUL\CVI\400315.0DOT_EC2123A_US75\Design-Working\STRC\Microstation\33788\11\Sheets\Bridges\33788\11\03.dgn

3/4/2021

P:\FDB\650-TUL\CIV\400315.0DOT_EC2123A_US75\Design-Working\STRC\Microstation\3378811\W5\Sheets\Bridg P\3378811-SIO GENERAL PLAN AND ELEVATION 04.dgn

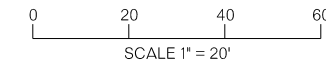

BENCHMARK 1B
3/8IP
STA. 107+68.14, 137.98' RT CLS I-44
STA. 271+67.95, 137.97' RT CRL I-44
N 402253.76, E 2556138.79, EL. 669.34

BENCHMARK 127A
CUT X ON HEADWALL
STA. 117+97.08, 130.61' RT CLS I-44
STA. 281+96.89, 130.55' RT CRL I-44
N 402277.28, E 2557167.48, EL. 647.773

BENCHMARK 127B
CUT X ON WEST ENDHEADWALL
STA. 119+15.21, 121.49' RT CLS I-44
STA. 283+15.01, 121.43' RT CRL I-44
N 402288.26, E 2557285.45, EL. 645.844

BENCHMARK 127C
CUT X ON CL HEADWALL
STA. 119+25.36, 155.62' RT CLS I-44
STA. 283+25.17, 155.56' RT CRL I-44
N 402254.29, E 2557296.14, EL. 645.458

BENCHMARK 127D
CUT X ON HEADWALL
STA. 121+96.90, 103.87' RT CLS I-44
STA. 285+96.71, 103.79' RT CRL I-44
N 402310.30, E 2557566.83, EL. 649.568

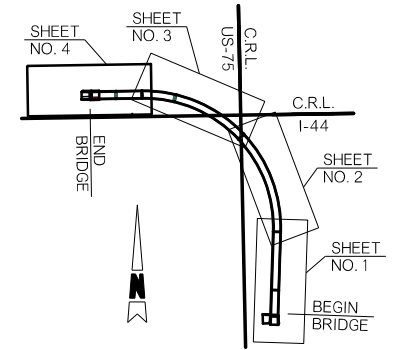

KEY MAP

- ① CONSTRUCTED IN WORK PACKAGE JP 33788(04).
- ② CONSTRUCTED IN WORK PACKAGE JP 33788(08).
- ③ PROPOSED MIN. VERTICAL CLEARANCE 31'-2" CRL RAMP E1 STA. 75+19.00 OFFSET 6'-0" L.T.

NOTES:
FOR DESIGN DATA, HYDRAULIC DATA, VERTICAL PROFILE DATA, & FOUNDATION DATA SEE SHEET NO. B037.

BRIDGE P, I-44 & US-75		TULSA COUNTY	Design	DS	4/20
RAMP E8 OVER MOOSER CREEK			Detail	TBG	6/20
GENERAL PLAN AND ELEVATION			Check	SOT	8/20
(SHEET 4 OF 5)					
CONSTRUCT 109'-108'-135'-117'-146'-165'-136'-183'-136'-108'-109' P.C. BEAM AND STEEL GIRDER SPAN, 29'-0" CLEAR ROADWAY W/ F-SHP PARAPETS, C.L. STA. 68+99.42					
STATE OF OKLAHOMA	DEPARTMENT OF TRANSPORTATION		JOB PIECE NO. 33788(11)		
				SHEET NO. B036	

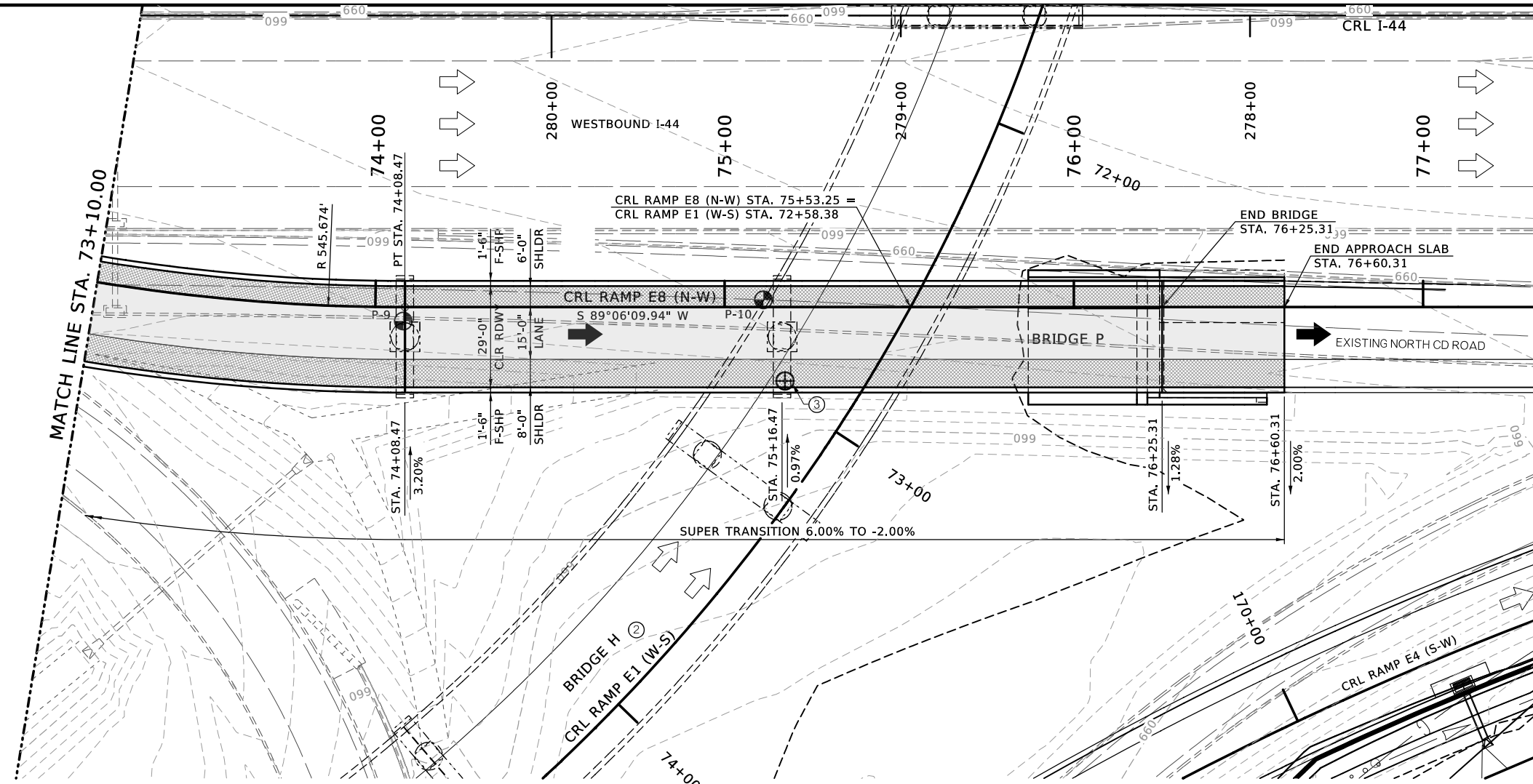

PLAN

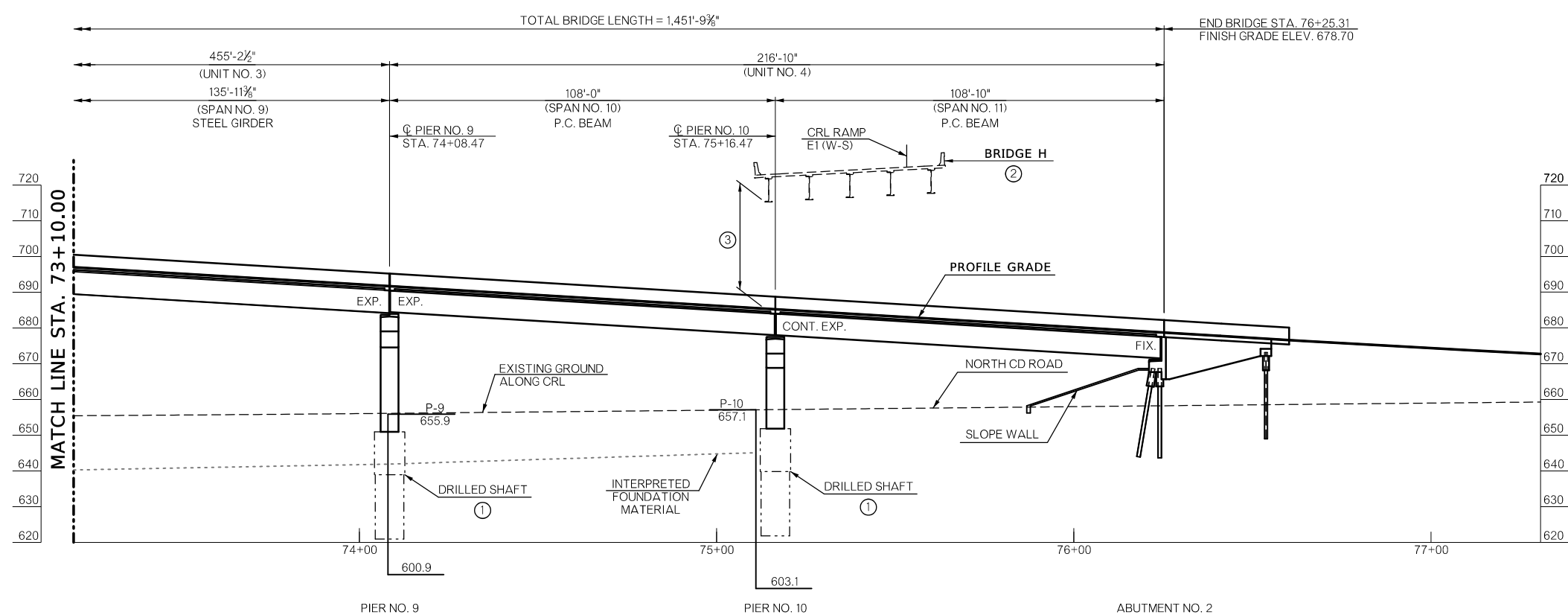

ELEVATION

R/W UTILITY MEETING

MARCH 2021

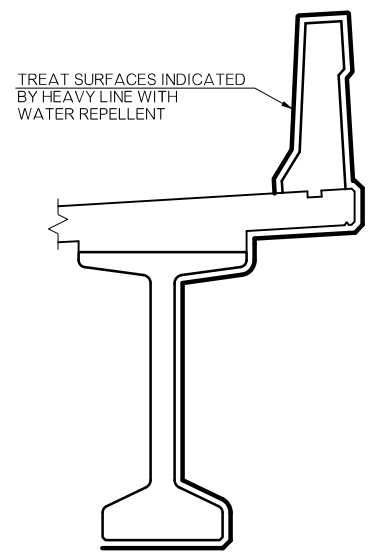
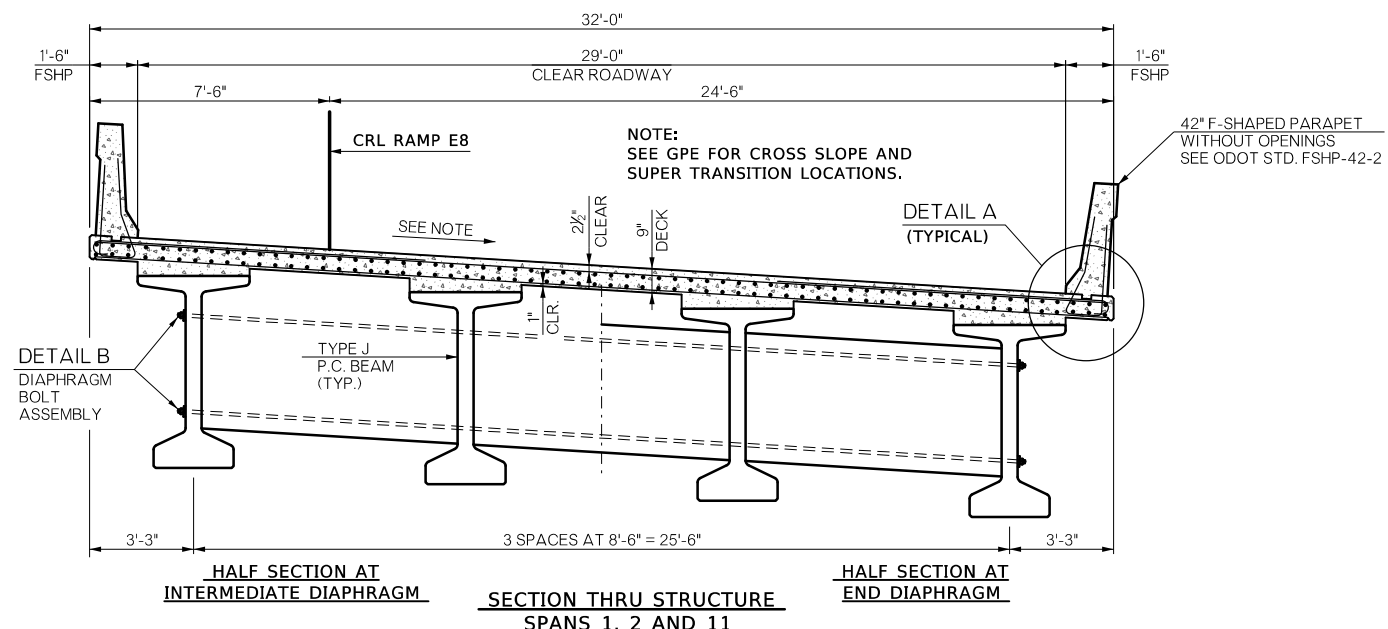

WATER REPELLENT TREATMENT DETAIL

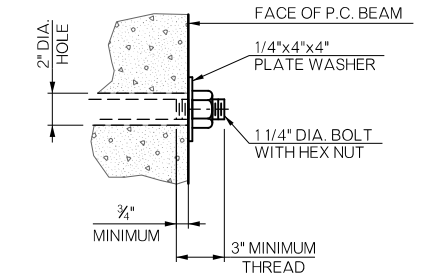

DIAPHRAGM BOLT NOTES
 PROVIDE STRUCTURAL STEEL FOR DIAPHRAGM BOLTS AND PLATE WASHERS IN ACCORDANCE WITH AASHTO M270 (ASTM A709), GRADE 50W (WEATHERING STEEL, CHARPY V-NOTCH TESTING NOT REQUIRED). THE CONTRACTOR MAY SUBSTITUTE A #10 REINFORCING BAR IN ACCORDANCE WITH AASHTO M31, GRADE 60, AND THREADED AT THE ENDS AS SHOWN FOR THE DIAPHRAGM BOLT AT NO ADDITIONAL COST TO THE DEPARTMENT. PROVIDE HEX NUTS IN ACCORDANCE WITH AASHTO M291 (ASTM A563).
 PAINT EXPOSED DIAPHRAGM BOLT, PLATE WASHER AND HEX NUT WITH TWO (2) COATS OF ZINC-RICH PAINT (6 MIL MINIMUM THICKNESS) AFTER ASSEMBLY. INCLUDE ALL COST OF DIAPHRAGM BOLT, PLATE WASHER AND HEX NUT IN THE CONTRACT PRICE FOR "STRUCTURAL STEEL M270 GRADE 50W".

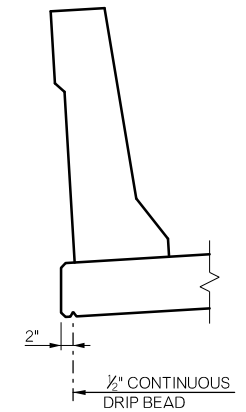

DETAIL A

DETAIL B

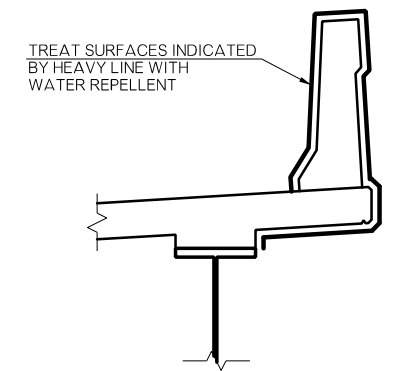
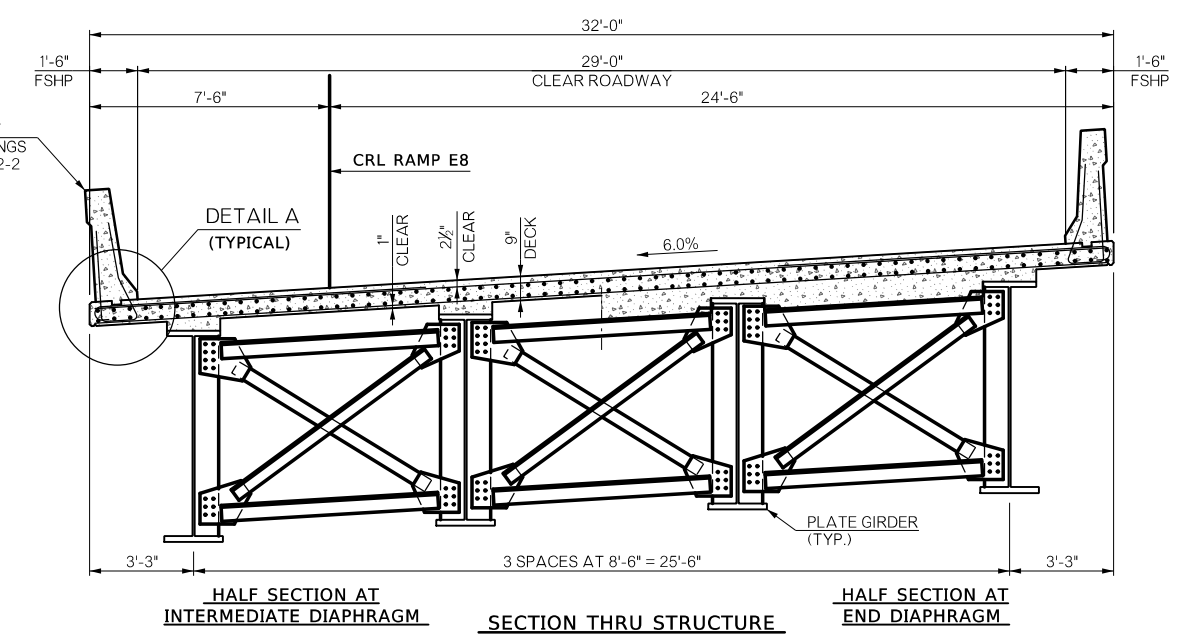

WATER REPELLENT TREATMENT DETAIL

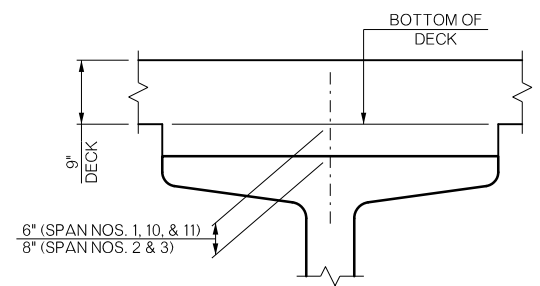

BEAM HAUNCH DETAIL (TYPE J)

NOTE:
 PLAN QUANTITIES FOR CLASS AA CONCRETE INCLUDE BEAM HAUNCHES. THE HAUNCH HEIGHT SHOWN IS THE THEORETICAL HAUNCH HEIGHT AT THE CENTERLINE BEARING ONLY, MEASURED FROM THE BOTTOM OF THE DECK SLAB TO THE TOP OF THE BEAM, AND VARIES ACROSS THE SPAN. DETERMINE THE ACTUAL HAUNCH HEIGHT (ACCOUNTING FOR BEAM CAMBER, DEAD LOAD DEFLECTION AND ROADWAY GRADE) AFTER ERECTION OF THE BEAMS AND SUBMIT TO THE ENGINEER FOR APPROVAL. THE ENGINEER WILL NOT MEASURE DIFFERENCES BETWEEN THE THEORETICAL AND THE ACTUAL HAUNCH HEIGHTS FOR PAYMENT.

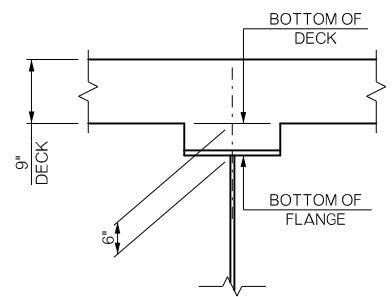
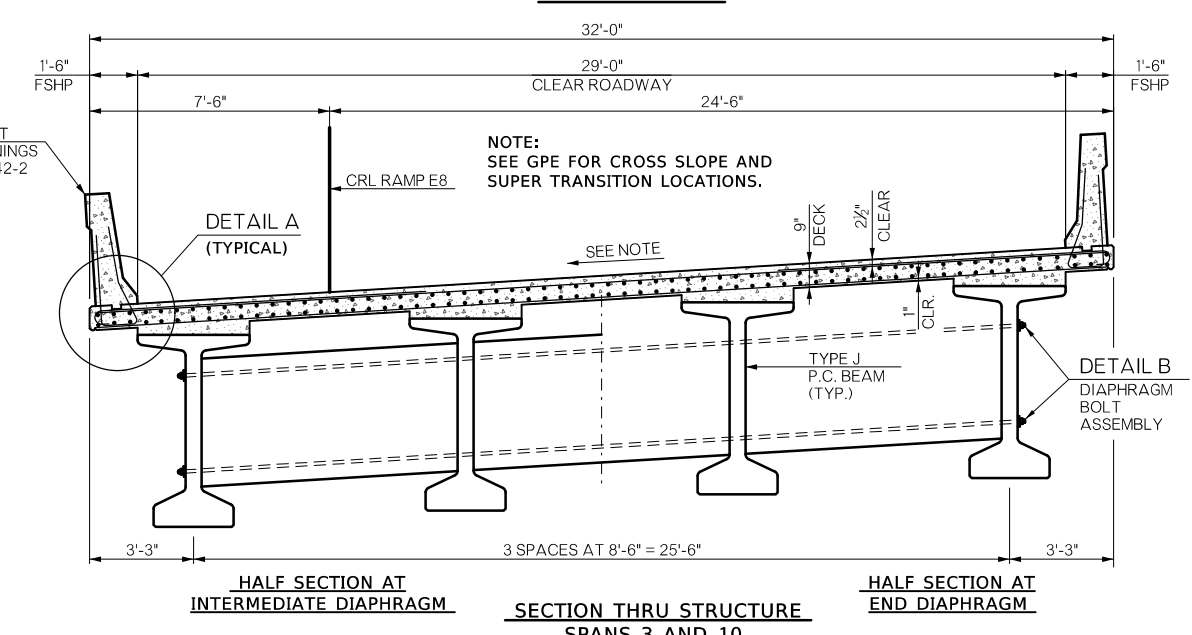

BEAM HAUNCH DETAIL (PLATE GIRDER)

NOTE:
 PLAN QUANTITIES FOR CLASS AA CONCRETE INCLUDE BEAM HAUNCHES. THE HAUNCH HEIGHT SHOWN IS THE THEORETICAL HAUNCH HEIGHT AT THE CENTERLINE BEARING ONLY, MEASURED FROM THE BOTTOM OF THE DECK SLAB TO THE TOP OF THE WEB, AND VARIES ACROSS THE SPAN. DETERMINE THE ACTUAL HAUNCH HEIGHT (ACCOUNTING FOR BEAM CAMBER, DEAD LOAD DEFLECTION AND ROADWAY GRADE) AFTER ERECTION OF THE BEAMS AND SUBMIT TO THE ENGINEER FOR APPROVAL. THE ENGINEER WILL NOT MEASURE DIFFERENCES BETWEEN THE THEORETICAL AND THE ACTUAL HAUNCH HEIGHTS FOR PAYMENT.

BRIDGE P, I-44 & US-75		TULSA COUNTY		Design	DS	4/20
RAMP E8 OVER MOOSER CREEK				Detail	TBG	6/20
SUPERSTRUCTURE DETAILS				Check	SOT	8/20
STATE OF OKLAHOMA	DEPARTMENT OF TRANSPORTATION					JOB PIECE NO. 33788(11)
				SHEET NO. B038		

P:\FDB\650-TUL\CVI\400315.0DOT_EC2123A_US75\Design-Work\King\STRC\Microstation\33788\WP5\Sheets\Bridg P\33788\110 TYPICAL_SECTION.dgn
 3/4/2021

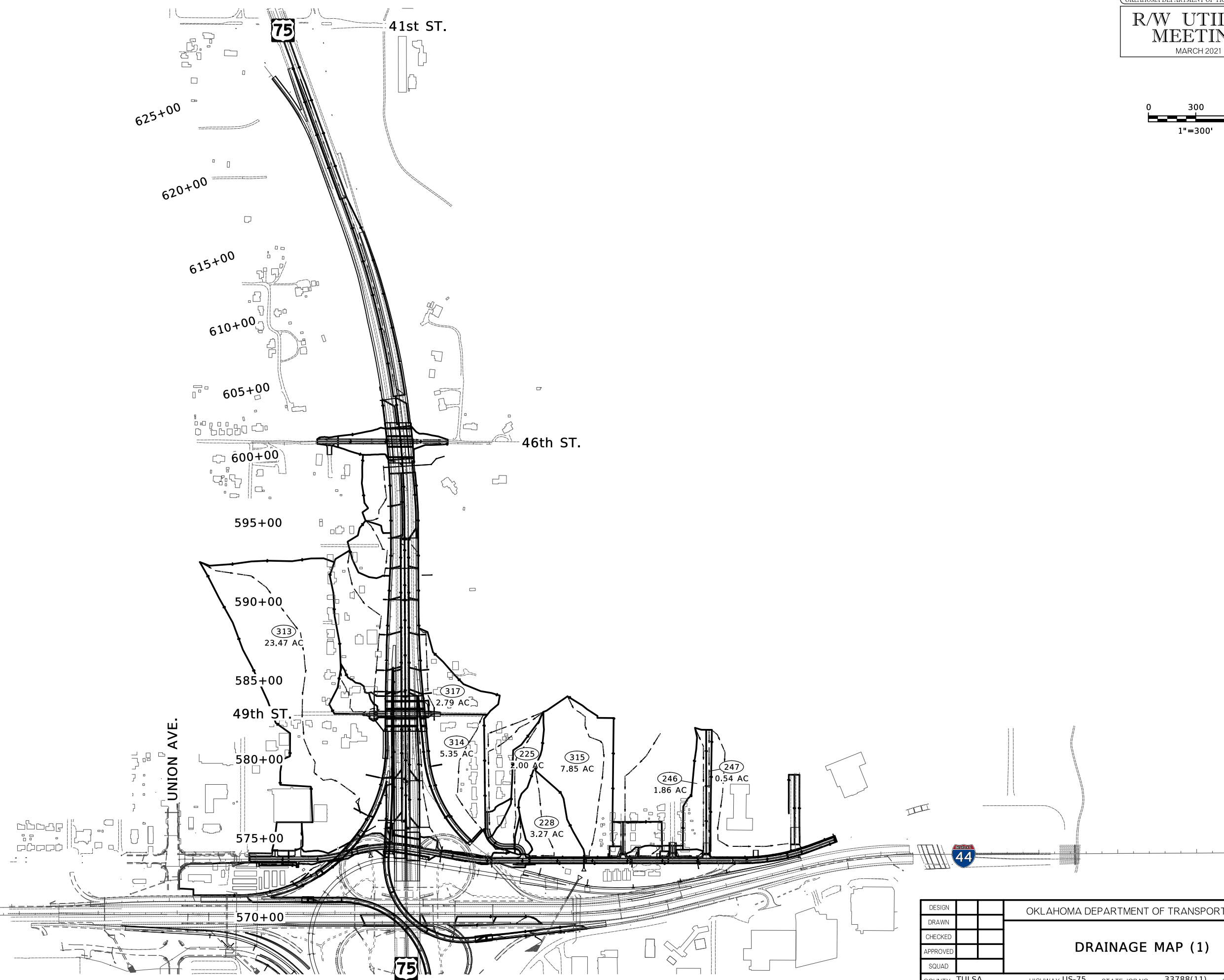
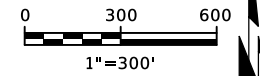

DESIGN		OKLAHOMA DEPARTMENT OF TRANSPORTATION
DRAWN		
CHECKED		
APPROVED		
SQUAD		
DRAINAGE MAP (1)		
COUNTY - TULSA		HIGHWAY US-75 STATE JOB NO. 33788(11) SHEET NO R001

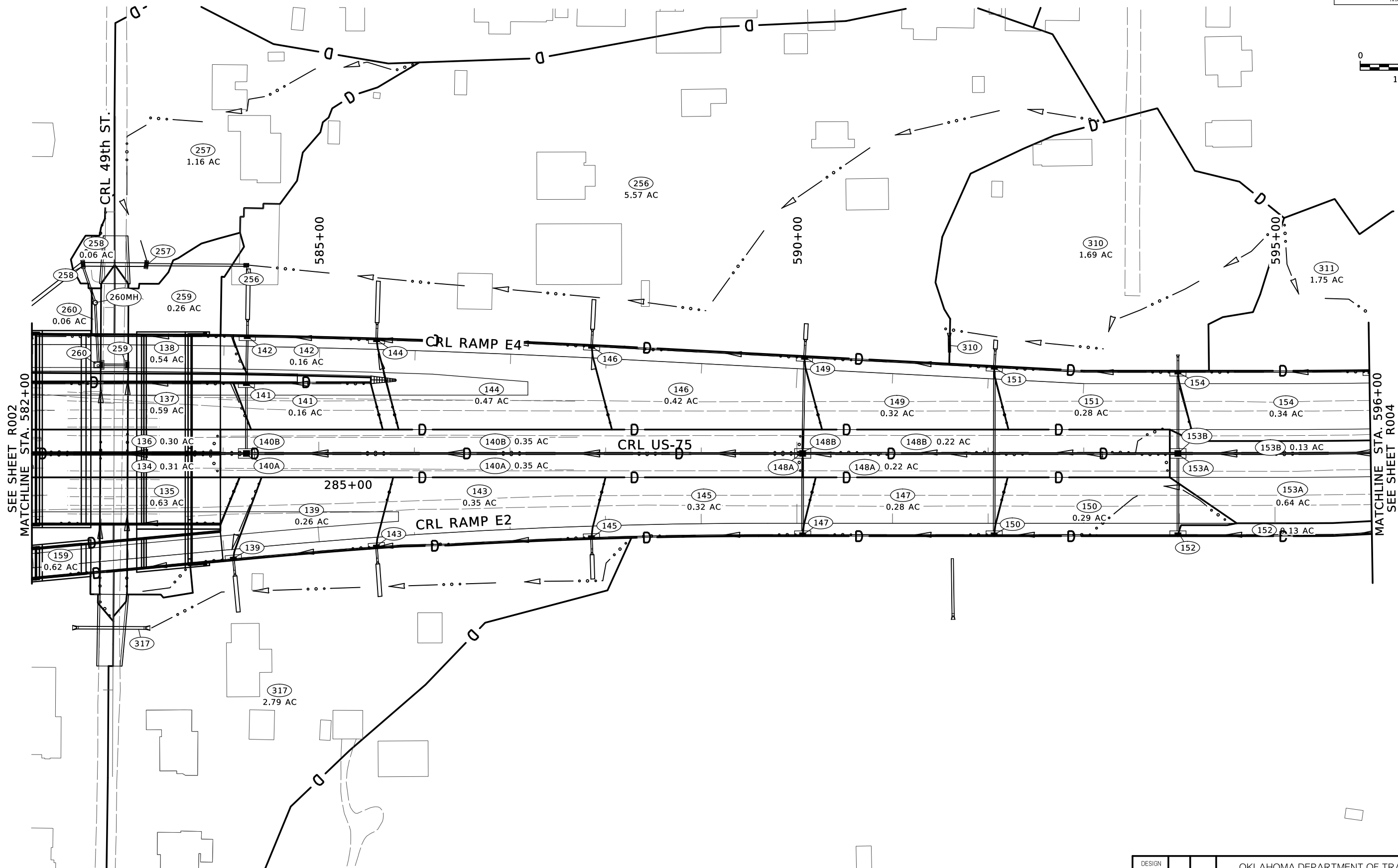
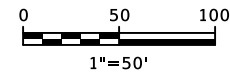

P:\FDB\1650-TUL\CIV\400315-000T_EC2123A_US75_Design-Working\CIV\MicroStation\33788(11)\P5\Sheets\33788(11)\Drainage_Map_03.dgn

SEE SHEET R002
MATCHLINE STA. 582+00

MATCHLINE STA. 596+00
SEE SHEET R004

DESIGN		OKLAHOMA DEPARTMENT OF TRANSPORTATION
DRAWN		
CHECKED		
APPROVED		
SQUAD		
COUNTY - TULSA		HIGHWAY US-75 STATE JOB NO. 33788(11) SHEET NO R003

DRAINAGE MAP (3)

R/W UTILITY MEETING

MARCH 2021

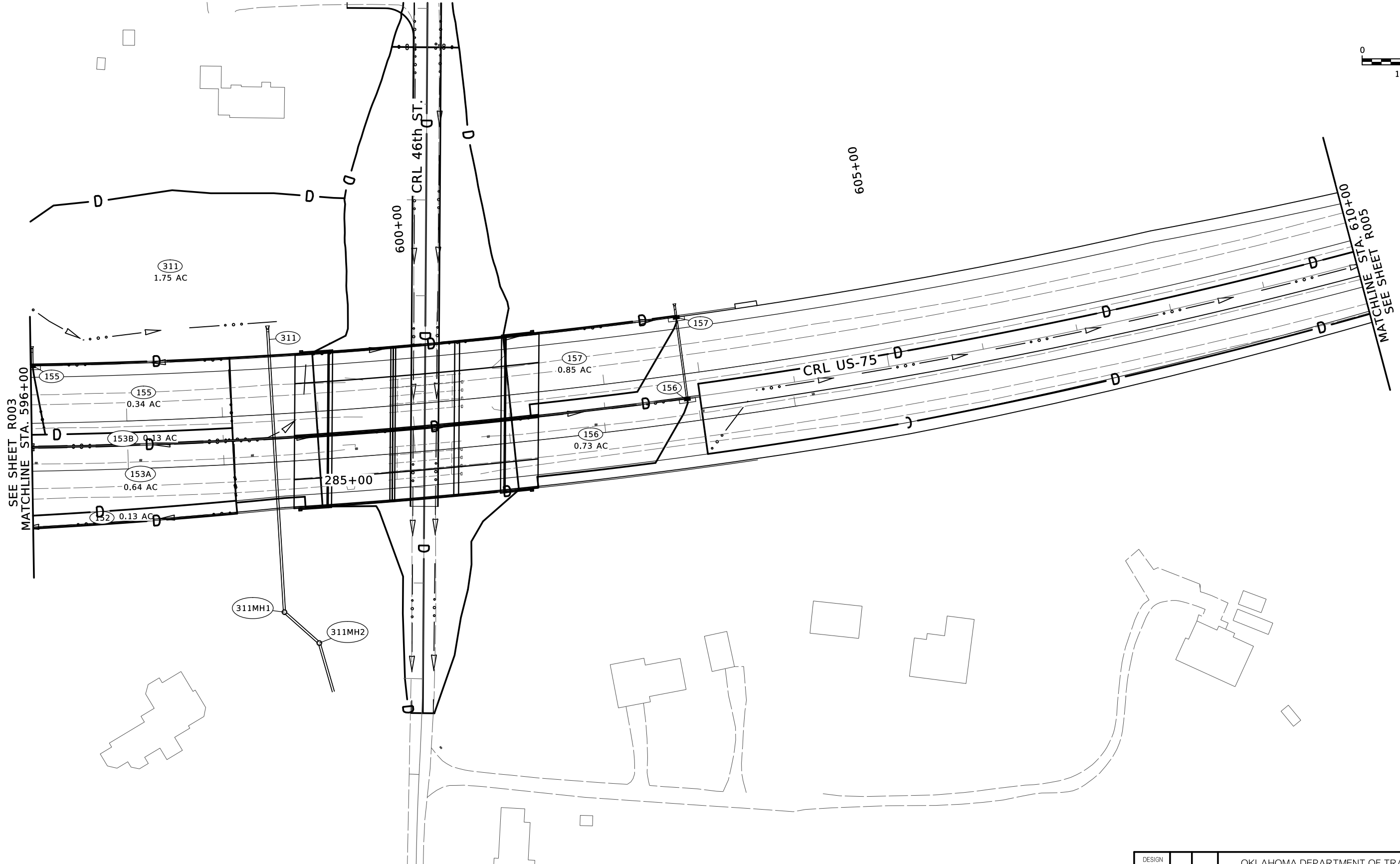
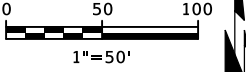

P:\FDB\1650-TUL\CIV\40035-000T_EC223A_US75\Design-Working\CIV\MicroStation\3378811-WP5\Sheets\3378811-Drainage_Map_04.dgn

DESIGN		OKLAHOMA DEPARTMENT OF TRANSPORTATION
DRAWN		
CHECKED		
APPROVED		
SQUAD		
COUNTY - TULSA		HIGHWAY US-75 STATE JOB NO. 33788(11) SHEET NO R004
DRAINAGE MAP (4)		

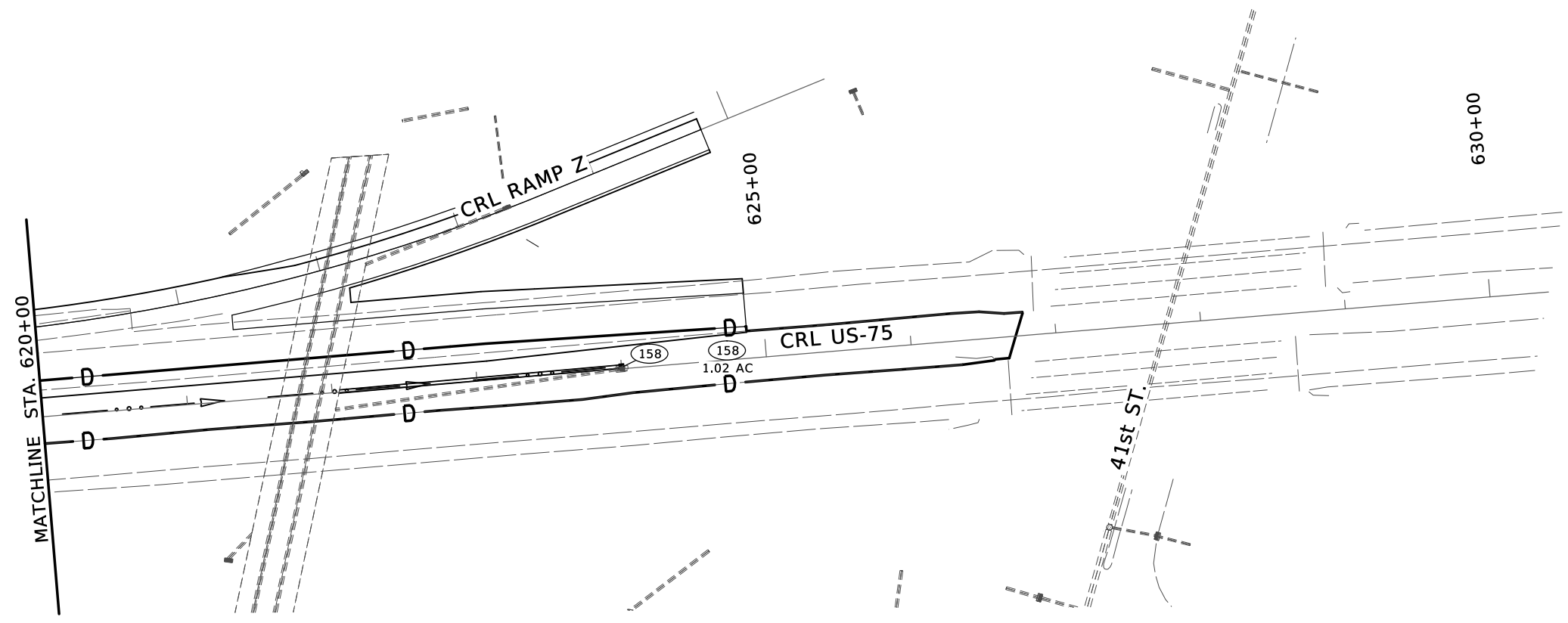
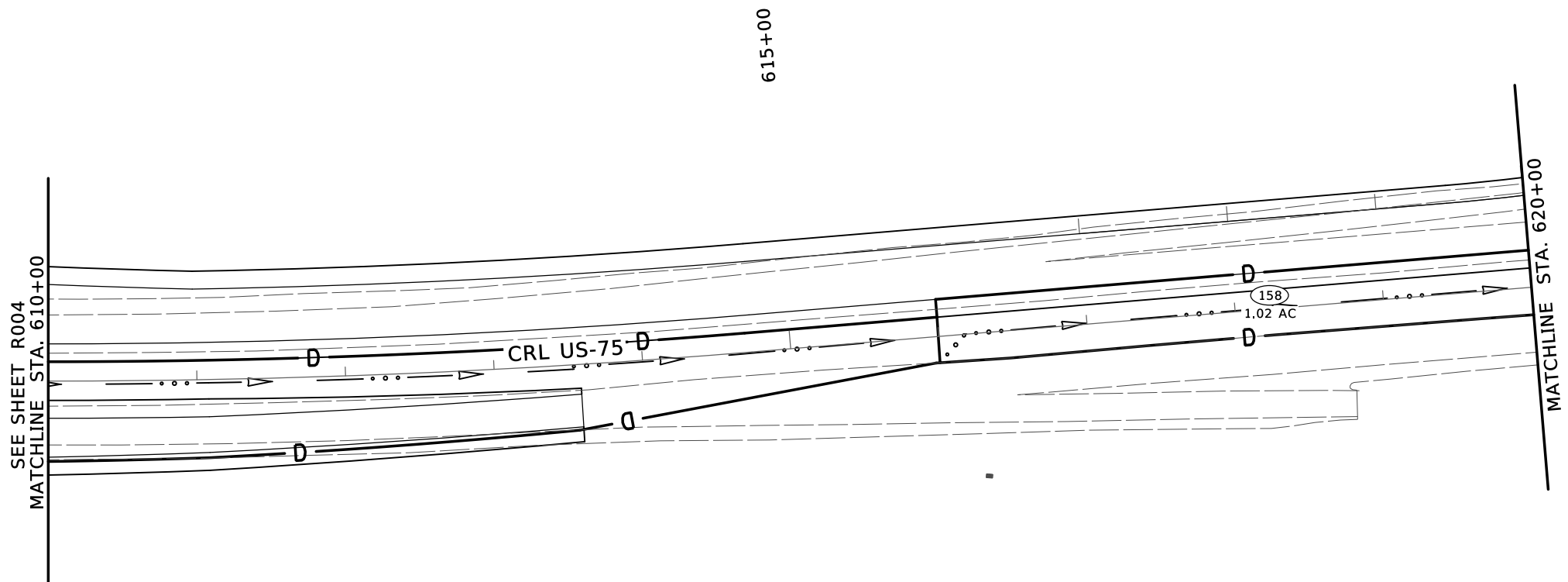
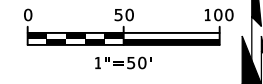

DESIGN	
DRAWN	
CHECKED	
APPROVED	
SQUAD	

OKLAHOMA DEPARTMENT OF TRANSPORTATION

DRAINAGE MAP (5)

COUNTY TULSA HIGHWAY US-75 STATE JOB NO. 33788(11) SHEET NO. R005

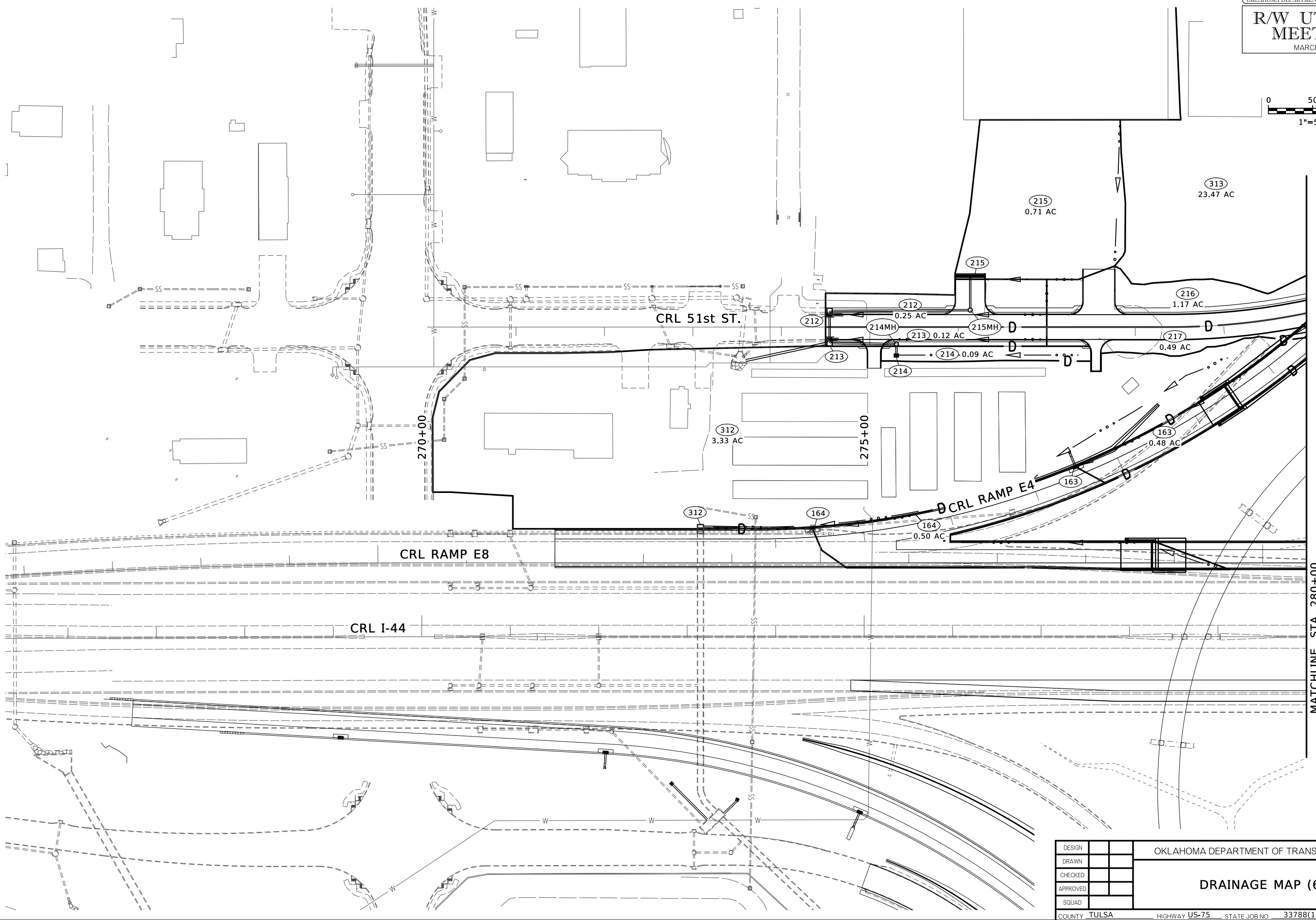
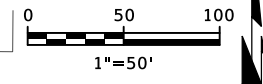

MATCHLINE STA: 280+00
SEE SHEET R002

DESIGN		OKLAHOMA DEPARTMENT OF TRANSPORTATION
DRAWN		
CHECKED		
APPROVED		
SQUAD		
DRAINAGE MAP (6)		
COUNTY	TULSA	HIGHWAY US-75 STATE JOB NO. 33788(11) SHEET NO R006

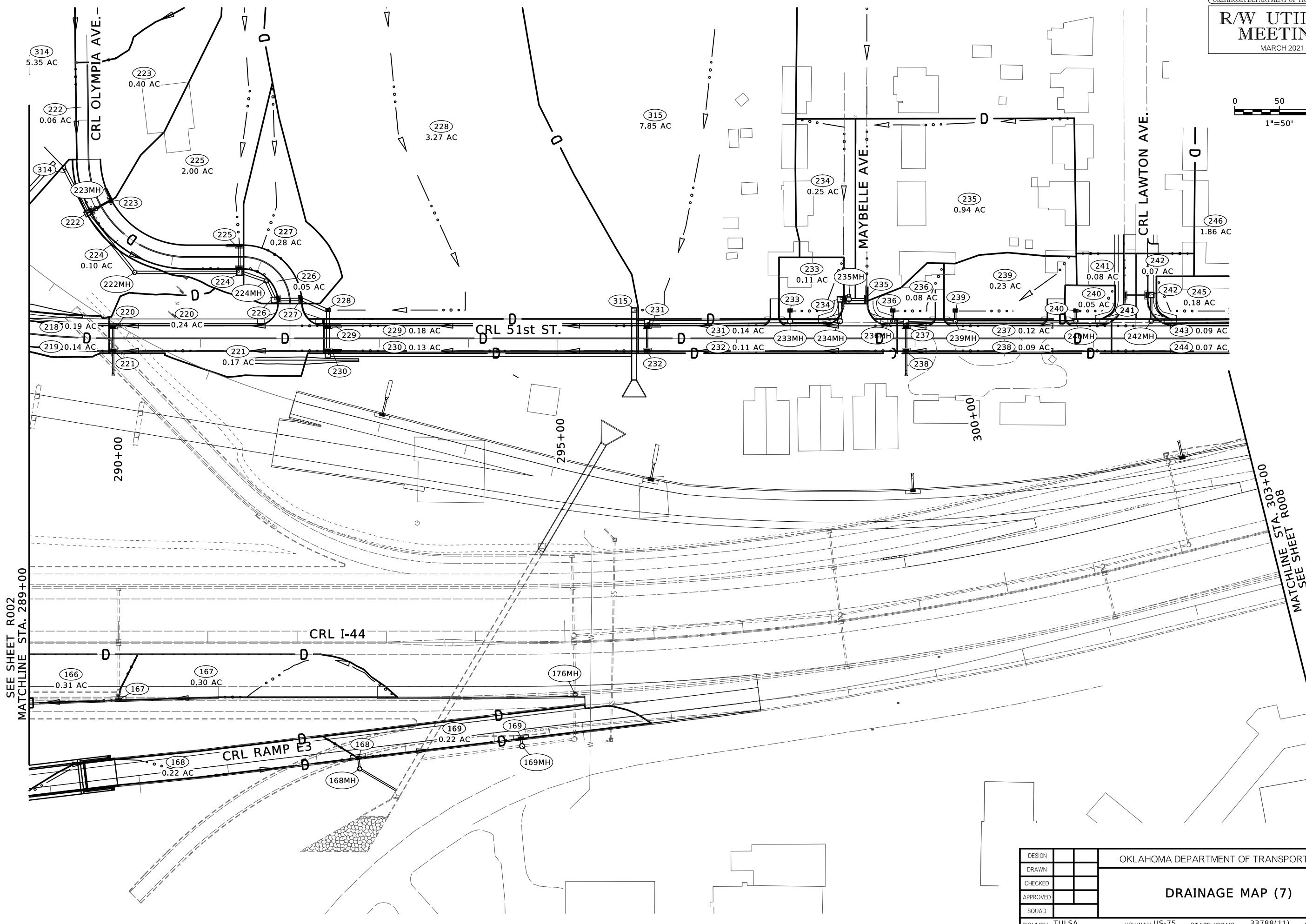
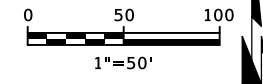

SEE SHEET R002
 MATCHLINE STA. 289+00

MATCHLINE STA. 303+00
 SEE SHEET R008

DESIGN		OKLAHOMA DEPARTMENT OF TRANSPORTATION
DRAWN		
CHECKED		
APPROVED		
SQUAD		
COUNTY - TULSA		STATE JOB NO. 33788(11) SHEET NO. R007

DRAINAGE MAP (7)

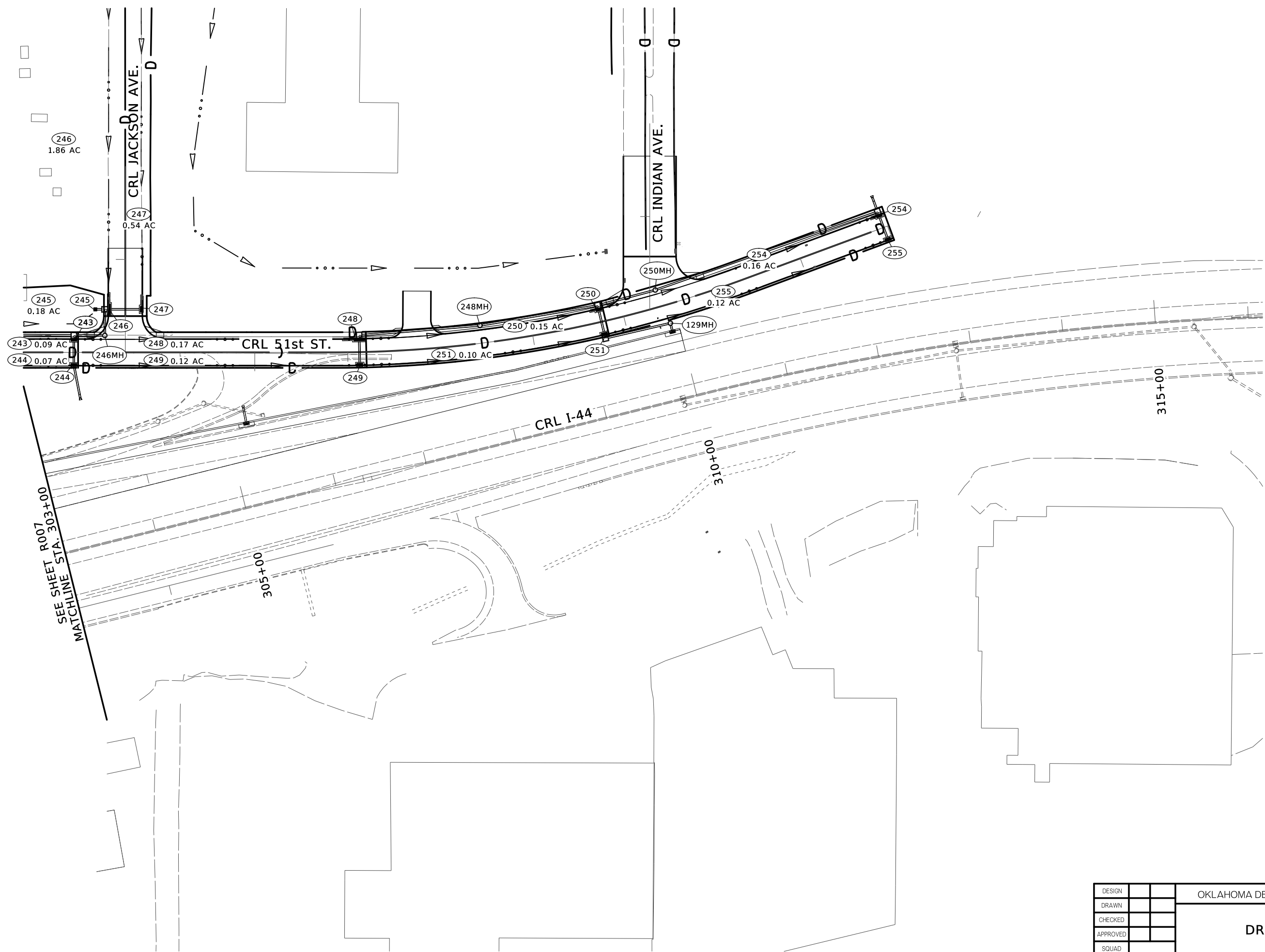
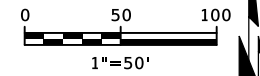

DESIGN		OKLAHOMA DEPARTMENT OF TRANSPORTATION
DRAWN		DRAINAGE MAP (8)
CHECKED		
APPROVED		
SQUAD		
COUNTY - TULSA		HIGHWAY US-75 STATE JOB NO. 33788(11) SHEET NO R008

R/W UTILITY MEETING

MARCH 2021

3/4/2021

F:\FDB\1650-TUL\CIV\40035-000T_EC223A_US75_Design-Working\CIV\MicroStation\33788il_WF5\Sheets\33788il-Drainage-Design_Record_01.dgn

DRAINAGE STRUCTURE DESIGN RECORD

STR. NO.	DESIGN YEAR	ALIGNMENT	STATION			DESCRIPTION	DRAINAGE AREA	ANTICIPATED LAND USE	C. RUNOFF COEFFICIENT WEIGHTED (ANTICIPATED)		AVG. SLOPE OF WATERSHED		LENGTH OF OVERLAND FLOW		SLOPE OF OVERLAND FLOW		LENGTH OF CHANNELFLOW		SLOPE OF CHANNEL		Tc TIME OF CONCENTRATION	INTENSITY OF DESIGN YEAR RAINFALL	DESIGN YEAR LOCAL DISCHARGE	TOTAL FLOW IN STRUCTURE		TOP OF GRATE	FL INLET	FL INLET @ VERTICAL BEND	REMOVAL OF EXISTING STRUCTURE	FL OUTLET @ VERTICAL BEND	FL OUTLET	REMOVAL OF EXISTING STRUCTURE	STRUCTURE SLOPE FL IN	EXISTING STRUCTURE SLOPE	STRUCTURE SLOPE FL OUT	HEADWATER	MAX ALLOWABLE HEADWATER	Tw DESIGN TAILWATER	FLOW VELOCITY	TYPE OF HYDRAULIC CONTROL	COMMENTS
									—	%	FT	%	FT	%	MIN	IN/HR	CFS	CFS	ELEV	ELEV				ELEV	ELEV																
218A	100	51ST STREET	526+77.93	46.77	LT	CONST. 24" X 33' RCP TIE ONTO STR. 218	1.90	100.00% PASTURE	0.55	5.97%	15.00	22.33%	775.18	5.66%	10.00	8.83	9.21	19.48	—	657.92	—	—	—	—	657.68	—	—	—	—	657.68	—	0.75	—	0.75	659.72	663.07	659.47	6.20	OUTLET		
310	50	US-75	591+61.06	0.00	CRL	EX. 24" X 237' RCP EXT. 14' LG LT. & 58' LG RT.	1.69	100.00% PASTURE	0.45	3.95%	242.59	4.43%	162.50	3.23%	15.92	6.81	5.17	16.24	—	700.26	697.90	2.00	682.36	682.02	2.00	13.24	7.07	0.55	700.86	709.88	683.75	5.17	OUTLET								
311	50	US-75	598+53.06	0.00	CRL	CONST. 24" X 292' RCP TIE ONTO STR. 311MH1	1.75	100.00% PASTURE	0.45	2.94%	227.32	4.38%	217.84	1.45%	16.39	6.73	5.29	7.28	—	703.31	—	—	—	—	671.34	—	10.75	—	10.75	703.73	712.62	671.77	14.98	OUTLET							
312	50	RAMP E4	165+15.13	0.00	CRL	CONST. INLET (CDI RCB DES. 11) TIE ONTO EX. 6" X 4' X 323' RCB EXT. 5' LG LT.	3.33	31.21% PASTURE, 68.79% COMMERCIAL	0.62	1.99%	14.98	21.08%	640.62	1.54%	10.00	8.07	16.71	171.96	654.20	645.80	—	2.00	—	645.70	—	0.30	0.30	0.30	650.88	654.20	649.15	8.15	INLET								
313	50	RAMP E4	175+38.76	0.00	CRL	EX. 4' X 4' X 246' RCB EXT. 54' LG LT. & 28' LG RT.	23.47	100.00% RESIDENTIAL	0.34	2.87%	1388.16	3.10%	727.84	2.42%	20.36	6.12	48.81	101.77	—	659.43	657.50	2.00	655.72	651.29	1.00	2.45	0.83	5.97	660.98	670.87	652.55	23.52	OUTLET								
314	100	OLYMPIA AVENUE	13+50.27	28.80	LT	CONST. 30" X 52' RCP TIE ONTO STR. 222	5.35	59.83% PASTURE, 38.34% RESIDENTIAL, 1.83% PAVED	0.48	2.54%	350.71	3.59%	506.21	1.81%	12.65	8.15	20.72	44.61	—	670.84	—	—	—	668.27	—	4.49	—	4.49	672.11	675.14	670.04	17.81	OUTLET								
315	100	51ST STREET	535+85.41	0.00	CRL	CONST. INLET (CDI RCB DES. 8) W/ 5' X 4' X 76' RCB	7.85	69.76% PASTURE, 27.87% RESIDENTIAL, 2.37% PAVED	0.47	3.18%	408.91	5.35%	750.78	1.99%	19.55	6.82	25.26	25.26	667.02	654.29	—	—	—	654.00	—	0.30	—	0.30	658.59	668.02	657.38	7.91	INLET								
317	50	49TH STREET	5+35.00	0.00	CRL	CONST. 30" X 69' RCP	2.79	97.32% RESIDENTIAL, 2.68% PAVED	0.41	5.00%	55.45	24.04%	481.11	2.81%	10.00	8.07	9.24	15.69	—	681.74	—	—	—	681.50	—	0.30	—	0.30	683.77	687.11	683.41	5.91	OUTLET								

DESIGN			OKLAHOMA DEPARTMENT OF TRANSPORTATION
DRAWN			DRAINAGE STRUCTURE DESIGN RECORD
CHECKED			
APPROVED			
SQUAD			
COUNTY	TULSA	HIGHWAY	
STATE JOB NO.		33788(11)	
SHEET NO.		R009	

STORM SEWER DESIGN RECORD

Table with columns: STR. NO., DESIGN YEAR, ALIGNMENT, STATION, DESCRIPTION, DRAINAGE AREA, ANTICIPATED LAND USE, C, RUNOFF COEFFICIENT WEIGHTED (ANTICIPATED), AVG. SLOPE OF WATERSHED, LENGTH OF OVERLAND FLOW, SLOPE OF OVERLAND FLOW, LENGTH OF CHANNEL FLOW, SLOPE OF CHANNEL, Tc, TIME OF CONCENTRATION, INTENSITY OF DESIGN YEAR RAINFALL, DESIGN YEAR LOCAL DISCHARGE, UPSTREAM BYPASS, UPSTREAM BYPASS INLET NUMBER, INTERCEPTED FLOW BY INLET, FLOW DOWNSTREAM, BYPASSED FLOW, BYPASSED TO INLET NUMBER, INLET EFFICIENCY, TOP OF GRATE/RIIM, FL IN OF EXITING PIPE, FL OUT OF EXITING PIPE, STRUCTURE DEPTH, SLOPE OF EXITING PIPE, SPREAD, DEPTH OF FLOW AT INLET, HYDRAULIC GRADELINE, ENERGY GRADELINE, COMMENTS.

DESIGN, DRAWN, CHECKED, APPROVED, SQUAD, OKLAHOMA DEPARTMENT OF TRANSPORTATION, STORM SEWER DESIGN RECORD (1), COUNTY - TULSA, HIGHWAY US-75, STATE JOB NO. 33788(11), SHEET NO R010

R/W UTILITY MEETING

MARCH 2021

STORM SEWER DESIGN RECORD

Table with columns: STR. NO., DESIGN YEAR, ALIGNMENT, STATION, DESCRIPTION, ANTICIPATED LAND USE, DRAINAGE AREA, C. RUNOFF COEFFICIENT WEIGHTED (ANTICIPATED), AVG. SLOPE OF WATERSHED, LENGTH OF OVERLAND FLOW, SLOPE OF OVERLAND FLOW, LENGTH OF CHANNELFLOW, SLOPE OF CHANNEL, Tc, TIME OF CONCENTRATION, INTENSITY OF DESIGN YEAR RAINFALL, DESIGN YEAR LOCAL DISCHARGE, UPSTREAM BYPASS, UPSTREAM BYPASS INLET NUMBER, INTERCEPTED FLOW BY INLET, FLOW DOWNSTREAM, BYPASSED FLOW, BYPASSED TO INLET NUMBER, INLET EFFICIENCY, TOP OF GRATE/IRIM, FL IN OF EXITING PIPE, FLOW OF EXITING PIPE, STRUCTURE DEPTH, SLOPE OF EXITING PIPE, SPREAD, DEPTH OF FLOW AT INLET, HYDRAULIC GRADELINE, ENERGY GRADELINE, COMMENTS.

3/4/2021

P:\FDB\1650-TUL CIVL\40035-000T_EC223A_US75-Design-Working\CVL_MicroStation\33788\1650-Sheets\33788\Drainage-Design_Record_03.dgn

DESIGN, DRAWN, CHECKED, APPROVED, SQUAD, COUNTY-TULSA, HIGHWAY US-75, STATE JOB NO. 33788(11), SHEET NO R011, OKLAHOMA DEPARTMENT OF TRANSPORTATION, STORM SEWER DESIGN RECORD (2)

STORM WATER MANAGEMENT PLAN

SITE DESCRIPTION

EROSION AND SEDIMENT CONTROLS

PROJECT LIMITS: THE EXTENTS OF IMPROVEMENTS TO US-75 ARE FROM THE I-44 INTERCHANGE TO THE 41ST STREET INTERCHANGE.

PROJECT DESCRIPTION: INTERCHANGE

SUGGESTED SEQUENCE OF EROSION CONTROL ACTIVITIES:

- 1) PLACE TEMPORARY SEDIMENT CONTROL DEVICES AT ALL OFF SITE DRAINAGE LOCATIONS.
- 2) PERFORM CLEARING & GRUBBING OPERATIONS, PRESERVING ANY EXISTING VEGETATION NOT IMPEDING CONSTRUCTION.
- 3) SALVAGE ALL AVAILABLE TOPSOIL IN THE AREA OF OPERATION AND STABILIZE THE STOCKPILED AREA.
- 4) AS GRADING OPERATIONS PROCEED, INSTALL TEMPORARY SEDIMENT CONTROL DEVICES AS SHOWN ON THE PLANS, AND AS DIRECTED BY THE ENGINEER. THESE DEVICES SHALL BE MAINTAINED AS REQUIRED BY THE O.D.O.T. STANDARD SPECIFICATIONS AND THE WEEKLY INSPECTION REPORTS.
- 5) PLACE TEMPORARY SEEDING AND/OR MULCHING OR PERMANENT GRASSING DEPENDING ON ULTIMATE SLOPES.
- 6) THE PERMANENT SEDIMENT CONTROL DEVICES SHALL BE MAINTAINED AS DESCRIBED IN SECTIONS 230, 232, 233, & 234 OF THE O.D.O.T. STANDARD SPECIFICATIONS OR AS DIRECTED BY THE ENGINEER.
- 7) IN AREAS WHERE PERMANENT SEDIMENT CONTROL DEVICES HAVE BEEN INSTALLED, THE TEMPORARY SEDIMENT CONTROL DEVICES SHALL BE REMOVED AS DIRECTED BY THE ENGINEER.

SOIL TYPE: SILTY CLAY & SANDY LOAM

TOTAL AREA OF THE CONSTRUCTION SITE: 52.64 AC

ESTIMATED AREA TO BE DISTURBED: 36.01 AC

OFFSITE AREA TO BE DISTURBED: (FOR CONTRACTOR USE)

TOTAL IMPERVIOUS AREA PRE-CONSTRUCTION: 16.63 AC

TOTAL IMPERVIOUS AREA POST-CONSTRUCTION: 23.07 AC

POST-CONSTRUCTION RUNOFF COEFFICIENT OF THE SITE: 0.79

LATITUDE & LONGITUDE OF CENTER OF PROJECT: 36°05'19.90" N; -96°00'24.00" W

PROJECT WILL DISCHARGE TO:

NAME OF RECEIVING WATERS: MOOSER CREEK

SENSITIVE WATERS OR WATERSHEDS: YES NO

303(d) IMPAIRED WATERS: YES NO

IF YES, LIST IMPAIRMENT: ESCHERICHIA COLI

LOCATED IN A TMDL: YES NO

LAKE THUNDERBIRD TMDL: YES NO

MS4 ENTITY YES NO

IF YES, LOCATION: TULSA

NOTE:
THIS SHEET SHOULD BE USED IN CONJUNCTION WITH A DRAINAGE MAP THAT ILLUSTRATES THE DRAINAGE PATTERNS/PATHWAYS AND RECEIVING WATERS FOR THIS PROJECT. THIS SHEET SHOULD ALSO BE USED WITH THE EROSION CONTROL SUMMARIES, PAY ITEMS, & NOTES.

SOIL STABILIZATION PRACTICES:

- TEMPORARY SEEDING
- PERMANENT SODDING, SPRIGGING OR SEEDING
- VEGETATIVE MULCHING
- SOIL RETENTION BLANKET
- PRESERVATION OF EXISTING VEGETATION

NOTE: TEMPORARY EROSION CONTROL METHODS MUST BE USED ON ALL DISTURBED AREAS WHERE CONSTRUCTION ACTIVITIES HAVE CEASED FOR OVER 14 DAYS. METHODS USED WILL BE AS SHOWN ON PLANS, OR AS DIRECTED BY THE ENGINEER.

STRUCTURAL PRACTICES:

- STABILIZED CONSTRUCTION EXIT
- TEMPORARY SILT FENCE
- TEMPORARY SILT DIKES
- TEMPORARY FIBER LOG
- DIVERSION, INTERCEPTOR OR PERIMETER DIKES
- DIVERSION, INTERCEPTOR OR PERIMETER SWALES
- ROCK FILTER DAMS
- TEMPORARY SLOPE DRAIN
- PAVED DITCH W/ DITCH LINER PROTECTION
- TEMPORARY DIVERSION CHANNELS
- TEMPORARY SEDIMENT BASINS
- TEMPORARY SEDIMENT TRAPS
- TEMPORARY SEDIMENT FILTERS
- TEMPORARY SEDIMENT REMOVAL
- RIP RAP
- INLET SEDIMENT FILTER
- TEMPORARY BRUSH SEDIMENT BARRIERS
- SANDBAG BERMS
- TEMPORARY STREAM CROSSINGS

OFFSITE VEHICLE TRACKING:

- HAUL ROADS DAMPENED FOR DUST CONTROL
- LOADED HAUL TRUCKS TO BE COVERED WITH TARPAILIN
- EXCESS DIRT ON ROAD REMOVED DAILY

NOTES:

NO DISTURBED AREA TO ONE PROJECT OUTFALL EXCEEDS 5 ACRES.

THE CONTRACTOR SHALL ALSO BE RESPONSIBLE FOR THE FOLLOWING:

MAINTENANCE AND INSPECTION:

ALL EROSION AND SEDIMENT CONTROLS WILL BE MAINTAINED IN GOOD WORKING ORDER FROM THE BEGINNING OF CONSTRUCTION UNTIL AN ACCEPTABLE VEGETATIVE COVER IS ESTABLISHED. INSPECTION BY THE CONTRACTOR AND ANY NECESSARY REPAIRS SHALL BE PERFORMED ONCE EVERY 7 CALENDAR DAYS AND WITHIN 24 HOURS AFTER ANY STORM EVENT GREATER THAN 0.5 INCH AS RECORDED BY A NON-FREEZING RAIN GAUGE TO BE LOCATED ON SITE. POTENTIALLY ERODIBLE AREAS, DRAINAGEWAYS, MATERIAL STORAGE, STRUCTURAL DEVICES, CONSTRUCTION ENTRANCES AND EXITS ALONG WITH EROSION AND SEDIMENT CONTROL LOCATIONS ARE EXAMPLES OF SITES THAT NEED TO BE INSPECTED.

WASTE MATERIALS:

PROPER MANAGEMENT AND DISPOSAL OF CONSTRUCTION WASTE MATERIAL IS REQUIRED BY THE CONTRACTOR. MATERIALS INCLUDE STOCKPILES, SURPLUS, DEBRIS AND ALL OTHER BY-PRODUCTS FROM THE CONSTRUCTION PROCESS. PRACTICES INCLUDE DISPOSAL, PROPER MATERIALS HANDLING, SPILL PREVENTION AND CLEANUP MEASURES. CONTROLS AND PRACTICES SHALL MEET THE REQUIREMENTS OF ALL FEDERAL, STATE AND LOCAL AGENCIES.

HAZARDOUS MATERIALS:

PROPER MANAGEMENT AND DISPOSAL OF HAZARDOUS WASTE MATERIALS IS REQUIRED. THE CONTRACTOR IS RESPONSIBLE FOR FOLLOWING MANUFACTURER'S RECOMMENDATIONS, STATE AND FEDERAL REGULATIONS TO ENSURE CORRECT HANDLING, DISPOSAL, SPILL PREVENTION AND CLEANUP MEASURES. EXAMPLES INCLUDE BUT ARE NOT LIMITED TO: PAINTS, ACIDS, CLEANING SOLVENTS, CHEMICAL ADDITIVES, CONCRETE CURING COMPOUNDS AND CONTAMINATED SOILS.

GENERAL NOTES:

A STORM WATER POLLUTION PREVENTION PLAN (SWPPP) IS REQUIRED TO COMPLY WITH THE OKLAHOMA POLLUTION DISCHARGE ELIMINATION SYSTEM (OPDES) REGULATIONS. THIS PLAN IS INITIATED DURING THE DESIGN PHASE, CONFIRMED IN THE PRE-WORK MEETINGS AND AVAILABLE ON THE JOB SITE ALONG WITH COPIES OF THE NOTICE OF INTENT (NOI) FORM AND PERMIT CERTIFICATE THAT HAVE BEEN FILED WITH THE OKLAHOMA DEPARTMENT OF ENVIRONMENTAL QUALITY (ODEQ). THE PLAN MUST BE KEPT CURRENT WITH UP-TO-DATE AMENDMENTS DURING THE PROGRESSION OF THE PROJECT. ALL CONTRACTOR OFF-SITE OPERATIONS ASSOCIATED WITH THE PROJECT MUST BE DOCUMENTED IN THE SWPPP, I.E., BORROW PITS, WORK ROADS, DISPOSAL SITES, ASPHALT/CONCRETE PLANTS, ETC. THE BASIC GOAL OF STORM WATER MANAGEMENT IS TO IMPROVE WATER QUALITY BY REDUCING POLLUTANTS IN STORM WATER DISCHARGES. RUNOFF FROM CONSTRUCTION SITES HAS A POTENTIAL FOR POLLUTION DUE TO EXPOSED SOILS AND THE PRESENCE OF HAZARDOUS MATERIALS USED IN THE CONSTRUCTION PROCESS. THE PREVENTION OF SOIL EROSION, CONTAINMENT OF HAZARDOUS MATERIALS AND/OR THE INTERCEPTION OF THESE POLLUTANTS BEFORE LEAVING THE CONSTRUCTION SITE ARE THE BEST PRACTICES FOR CONTROLLING STORM WATER POLLUTION.

THE FOLLOWING SECTIONS OF THE 2019 ODOT STANDARD SPECIFICATIONS SHOULD BE NOTED:

- 103.05 BONDING REQUIREMENTS
- 104.10 FINAL CLEANING UP
- 104.12 CONTRACTOR'S RESPONSIBILITY FOR WORK
- 104.13 ENVIRONMENTAL PROTECTION
- 106.08 STORAGE AND HANDLING OF MATERIAL
- 107.01 LAWS, RULES AND REGULATIONS TO BE OBSERVED
- 107.20 STORM WATER MANAGEMENT
- 220 MANAGEMENT OF EROSION, SEDIMENTATION AND STORM WATER POLLUTION PREVENTION AND CONTROL
- 221 TEMPORARY SEDIMENT CONTROL

IN ADDITION:

"ODEQ GENERAL PERMIT (OKR10) FOR STORM WATER DISCHARGES FROM CONSTRUCTION ACTIVITIES WITHIN THE STATE OF OKLAHOMA." ODEQ, WATER QUALITY DIVISION, SEPTEMBER 13, 2017.

DESIGN			OKLAHOMA DEPARTMENT OF TRANSPORTATION
DRAWN			
CHECKED			
APPROVED			
SQUAD			
COUNTY - <u>TULSA</u> HIGHWAY <u>US-75</u> STATE JOB NO. <u>33788(11)</u> SHEET NO. <u>R012</u>			STORMWATER MANAGEMENT PLAN

SEC. 2, T18N, R12E

SEC. 35, T19N, R12E

R/W UTILITY MEETING

MARCH 2021

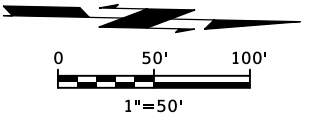

480+00

550+00

555+00

STA. 547+19.08 CRL US-75=
 N 400118.1794
 E 2557467.4844

CRL US-75

N1°10'15.96"W
 9511.78'

POB 480+00.00
 US-75

POB 57+45.89
 RAMP E8

CRL RAMP E8

N1°49'44.04"E
 779.48'

MATCHLINE STA. 60+00 SEE SHEET R014
 MATCHLINE STA. 560+00 SEE SHEET R014

1/4 Section Line

DESIGN	
DRAWN	
CHECKED	
APPROVED	
SQUAD	

OKLAHOMA DEPARTMENT OF TRANSPORTATION

GEOMETRIC DATA (1)

SEC. 35, T19N, R12E

SEE SHEET R018
MATCHLINE
STA. 75+00

SEE SHEET R018
MATCHLINE
STA. 280+00

R/W UTILITY
MEETING

MARCH 2021

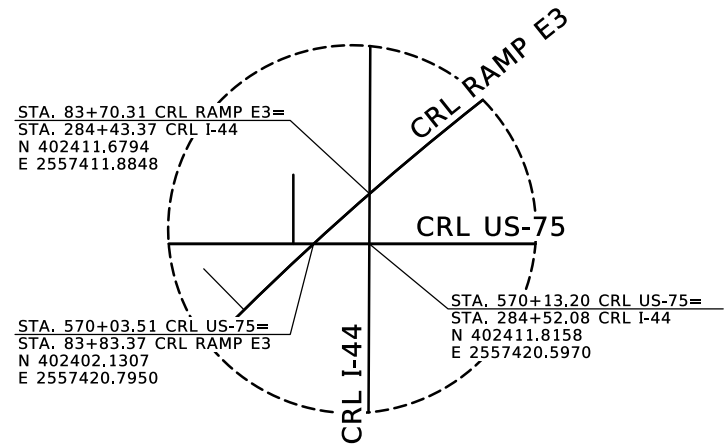
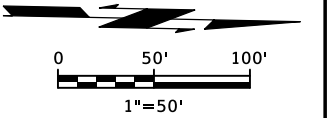

DETAIL 'A'

SEE SHEET R018
MATCHLINE STA. 521+00

SEC. 26,
T19N, R12E

MATCHLINE
STA. 79+00
SEE SHEET R015

MATCHLINE STA. 575+00
SEE SHEET R015

SEE SHEET R013
MATCHLINE STA. 60+00

SEE SHEET R013
MATCHLINE STA. 560+00

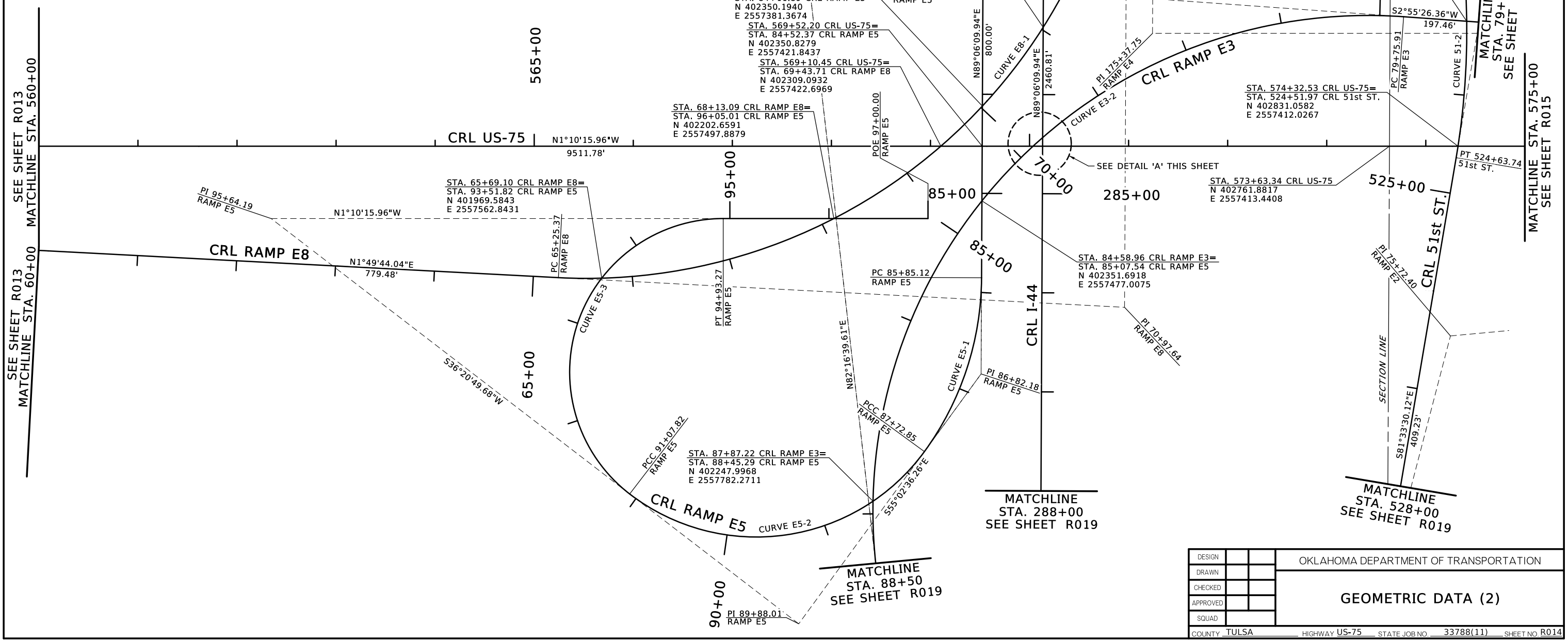

DESIGN		OKLAHOMA DEPARTMENT OF TRANSPORTATION
DRAWN		
CHECKED		
APPROVED		
SQUAD		
COUNTY - TULSA		HIGHWAY US-75 STATE JOB NO. 33788(11) SHEET NO R014
GEOMETRIC DATA (2)		

SEC. 26, T19N, R12E

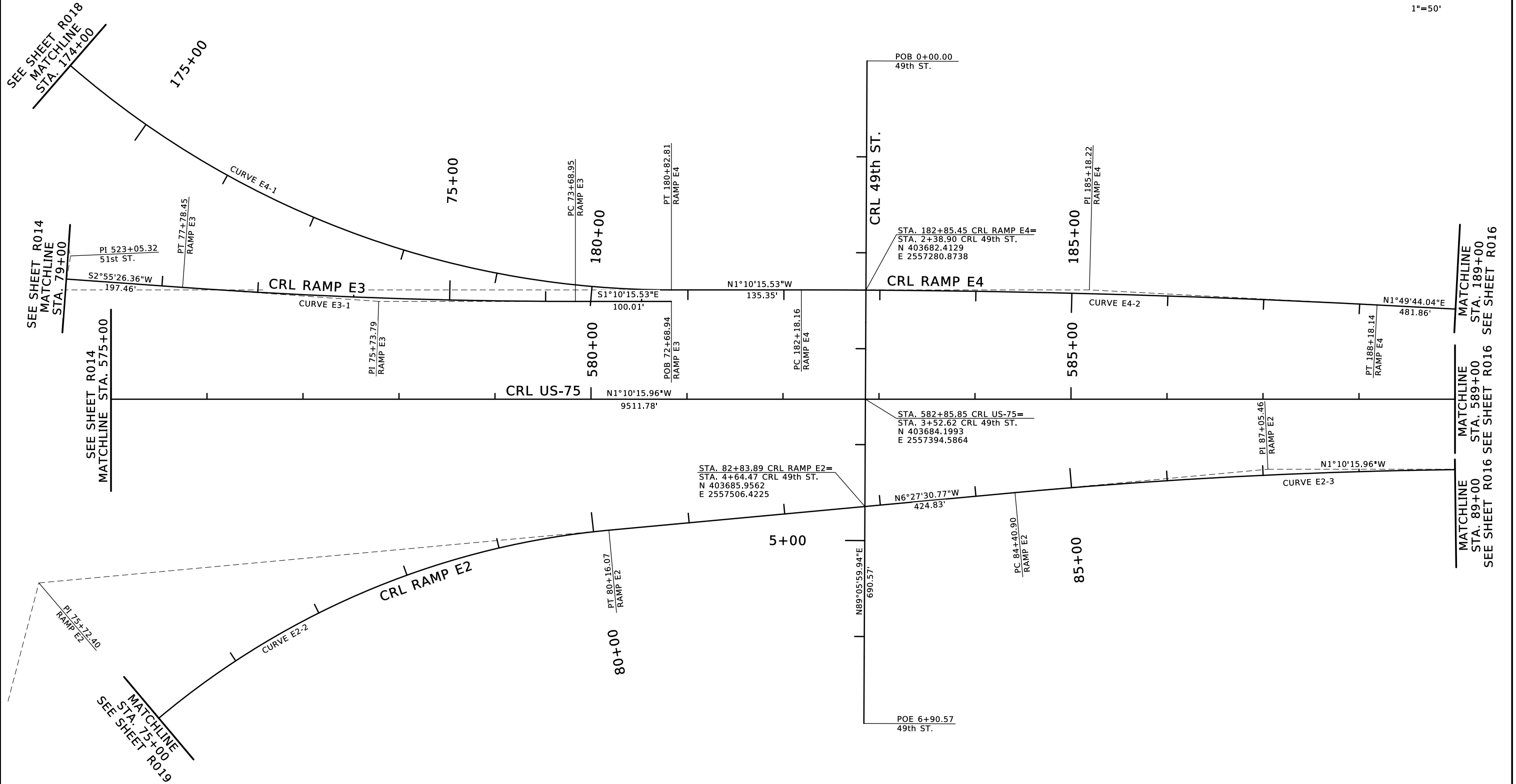

DESIGN		OKLAHOMA DEPARTMENT OF TRANSPORTATION
DRAWN		GEOMETRIC DATA (3)
CHECKED		
APPROVED		
SQUAD		
COUNTY - TULSA		HIGHWAY US-75 STATE JOB NO. 33788(11) SHEET NO R015

SEC. 26, T19N, R12E

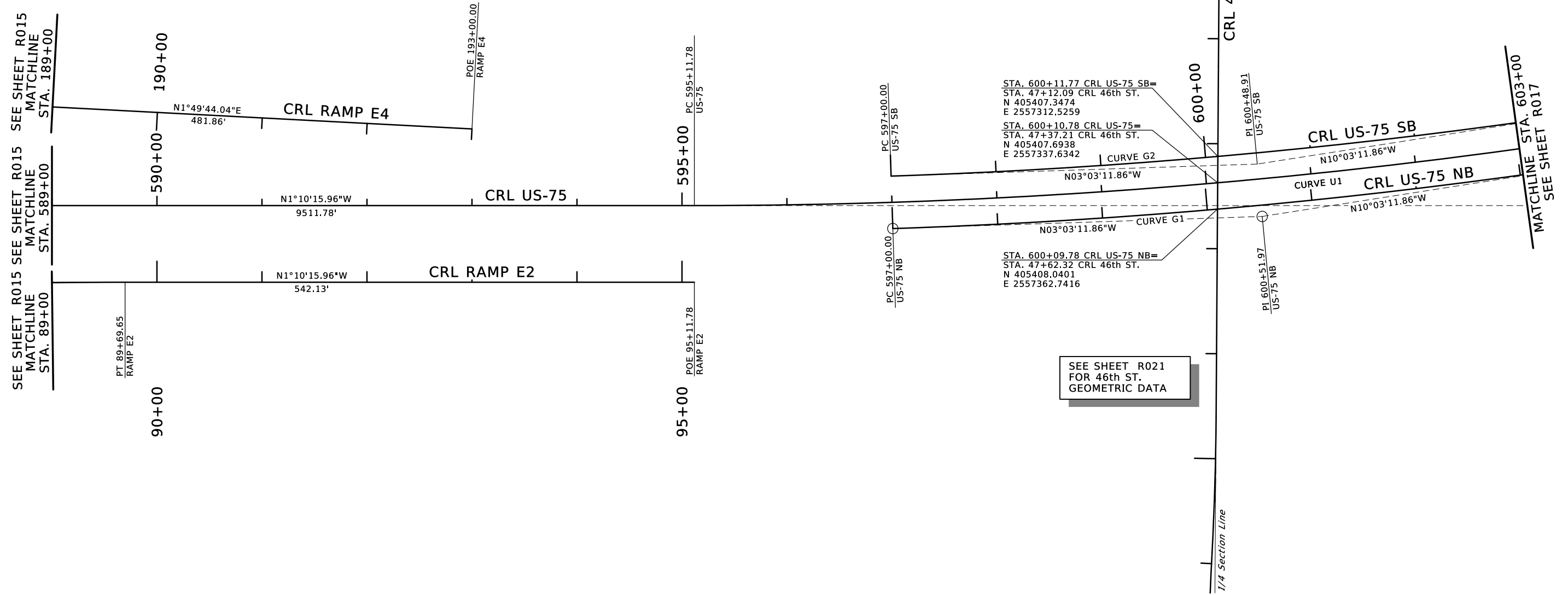
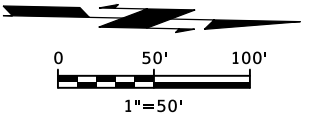

SEE SHEET R015 SEE SHEET R015
MATCHLINE MATCHLINE
STA. 89+00 STA. 189+00

MATCHLINE STA. 603+00
SEE SHEET R017

SEE SHEET R021
FOR 46th ST.
GEOMETRIC DATA

DESIGN		OKLAHOMA DEPARTMENT OF TRANSPORTATION
DRAWN		GEOMETRIC DATA (4)
CHECKED		
APPROVED		
SQUAD		
COUNTY - TULSA		HIGHWAY US-75 STATE JOB NO. 33788(11) SHEET NO. R016

SEC. 26, T19N, R12E

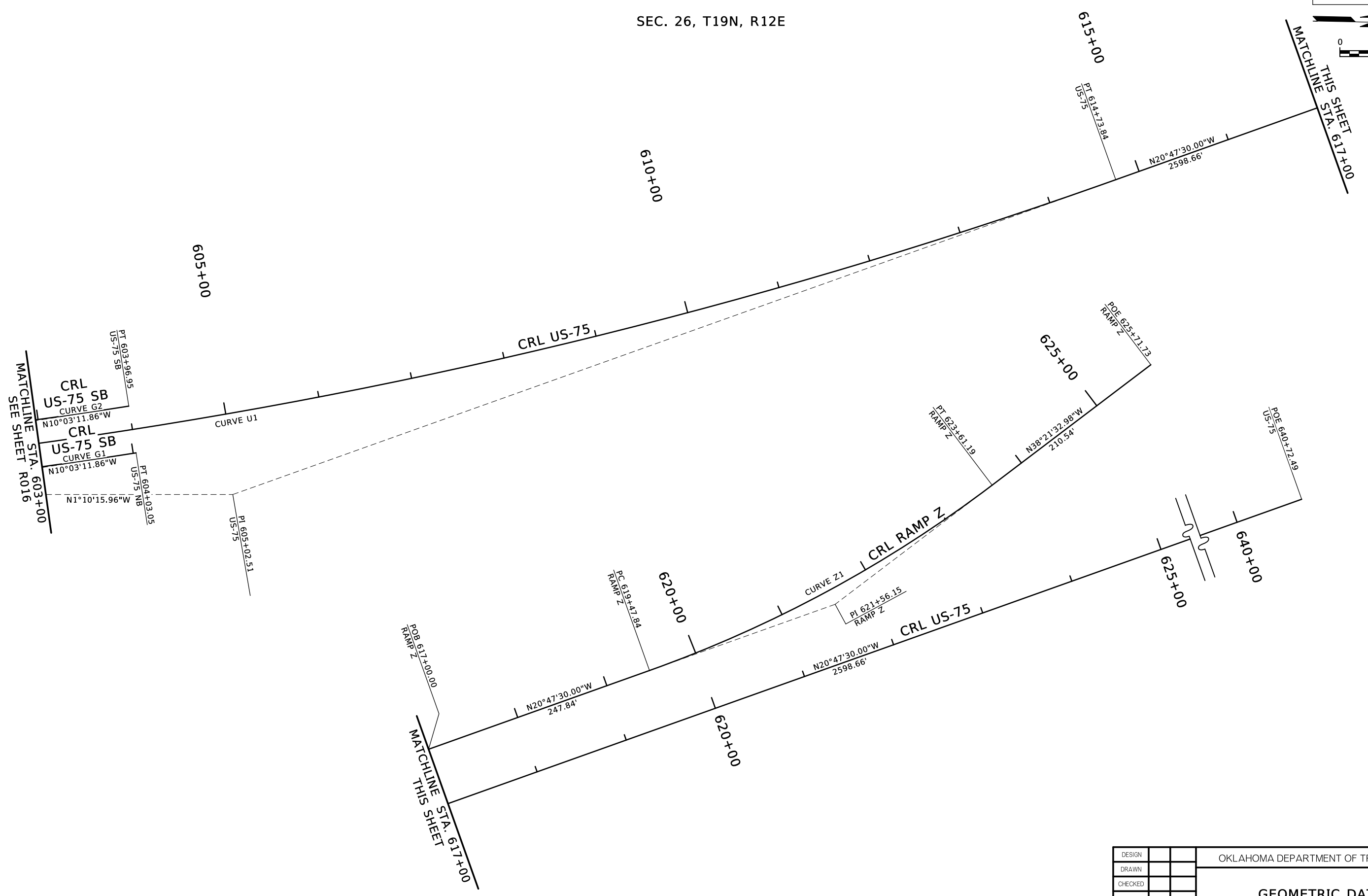
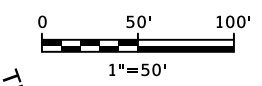

DESIGN		OKLAHOMA DEPARTMENT OF TRANSPORTATION
DRAWN		GEOMETRIC DATA (5)
CHECKED		
APPROVED		
SQUAD		
COUNTY - TULSA		HIGHWAY US-75 STATE JOB NO. 33788(11) SHEET NO. R017

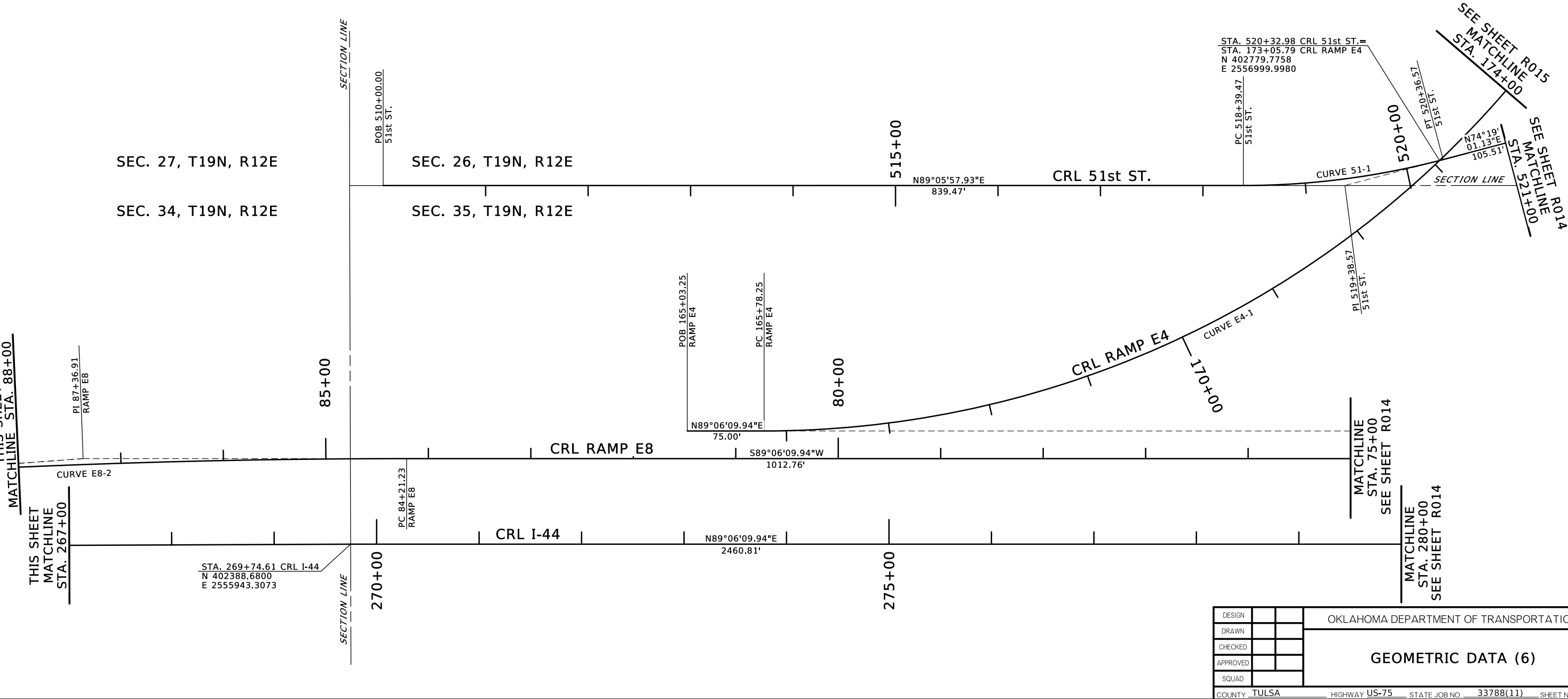
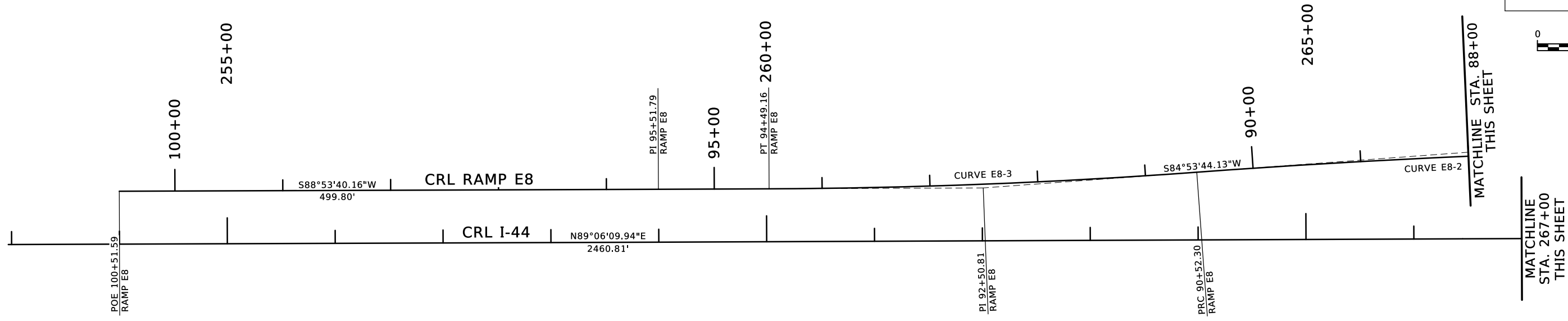
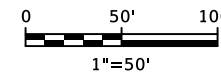

DESIGN	
DRAWN	
CHECKED	
APPROVED	
SQUAD	

OKLAHOMA DEPARTMENT OF TRANSPORTATION

GEOMETRIC DATA (6)

COUNTY TULSA HIGHWAY US-75 STATE JOB NO. 33788(11) SHEET NO R018

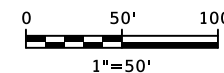

SEC. 26, T19N, R12E

SEC. 35, T19N, R12E

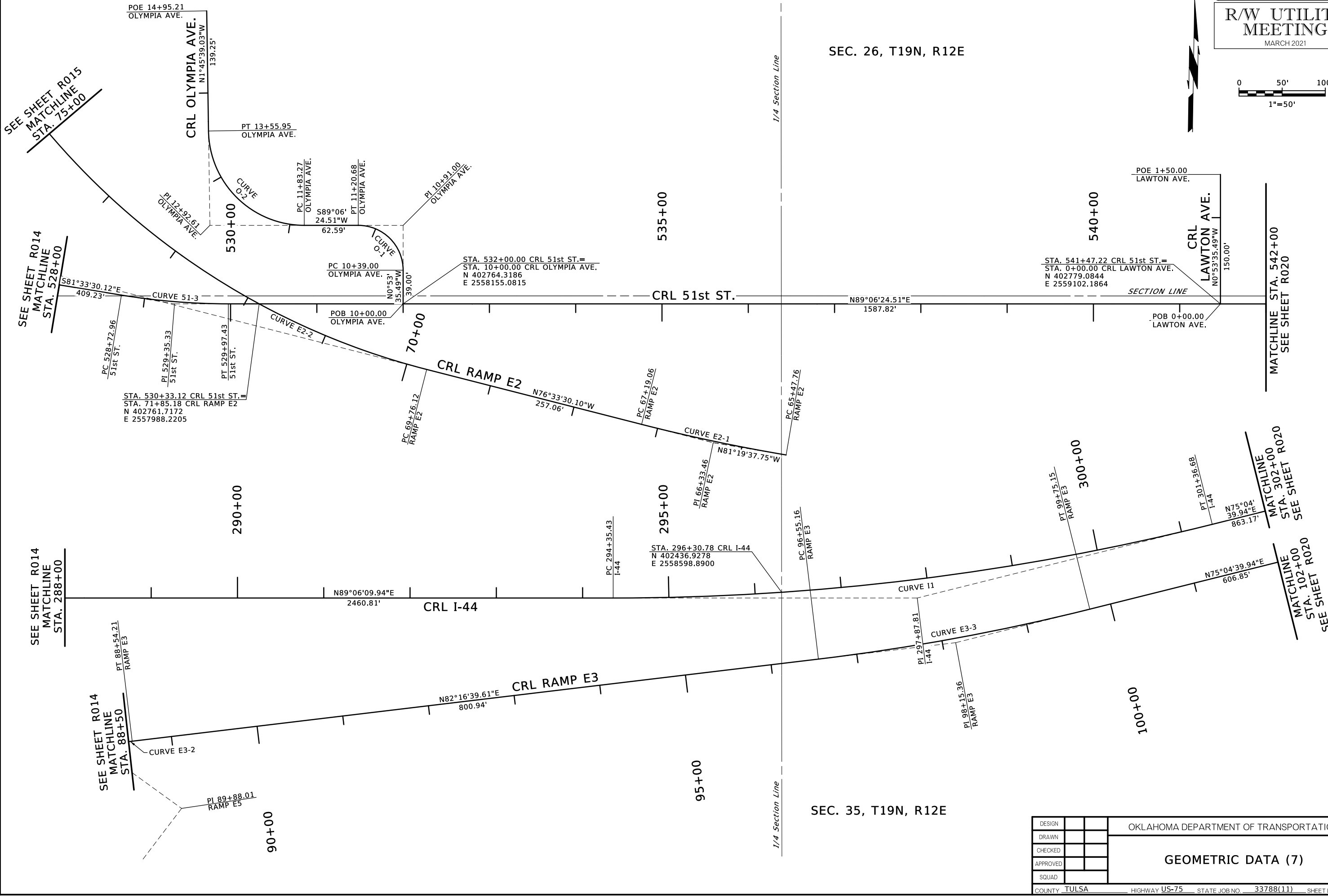

DESIGN		OKLAHOMA DEPARTMENT OF TRANSPORTATION
DRAWN		
CHECKED		
APPROVED		
SQUAD		
COUNTY - TULSA		HIGHWAY US-75 STATE JOB NO. 33788(11) SHEET NO R019
<p style="text-align: center;">GEOMETRIC DATA (7)</p>		

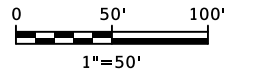

SEC. 26, T19N, R12E

SEC. 35, T19N, R12E

SEC. 26, T19N, R12E

SEC. 35, T19N, R12E

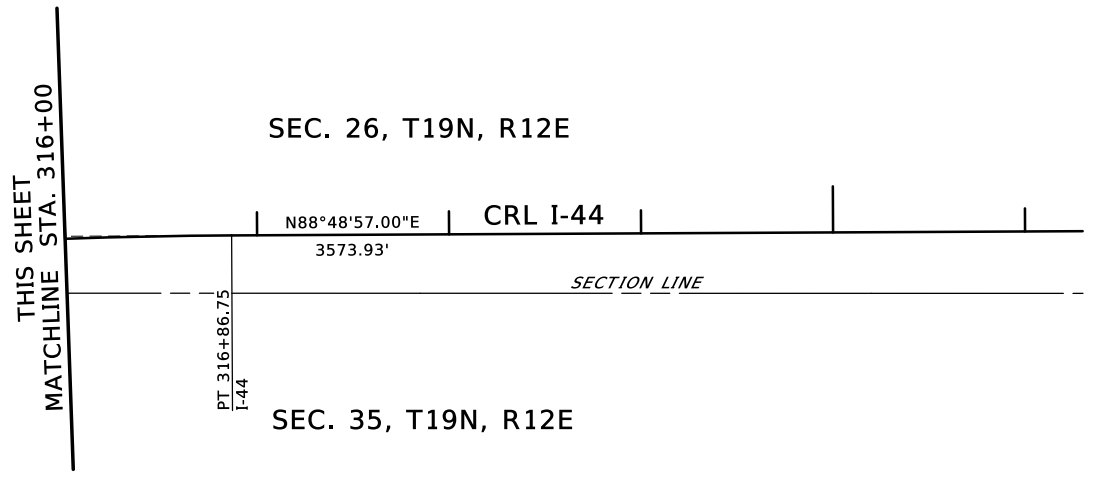
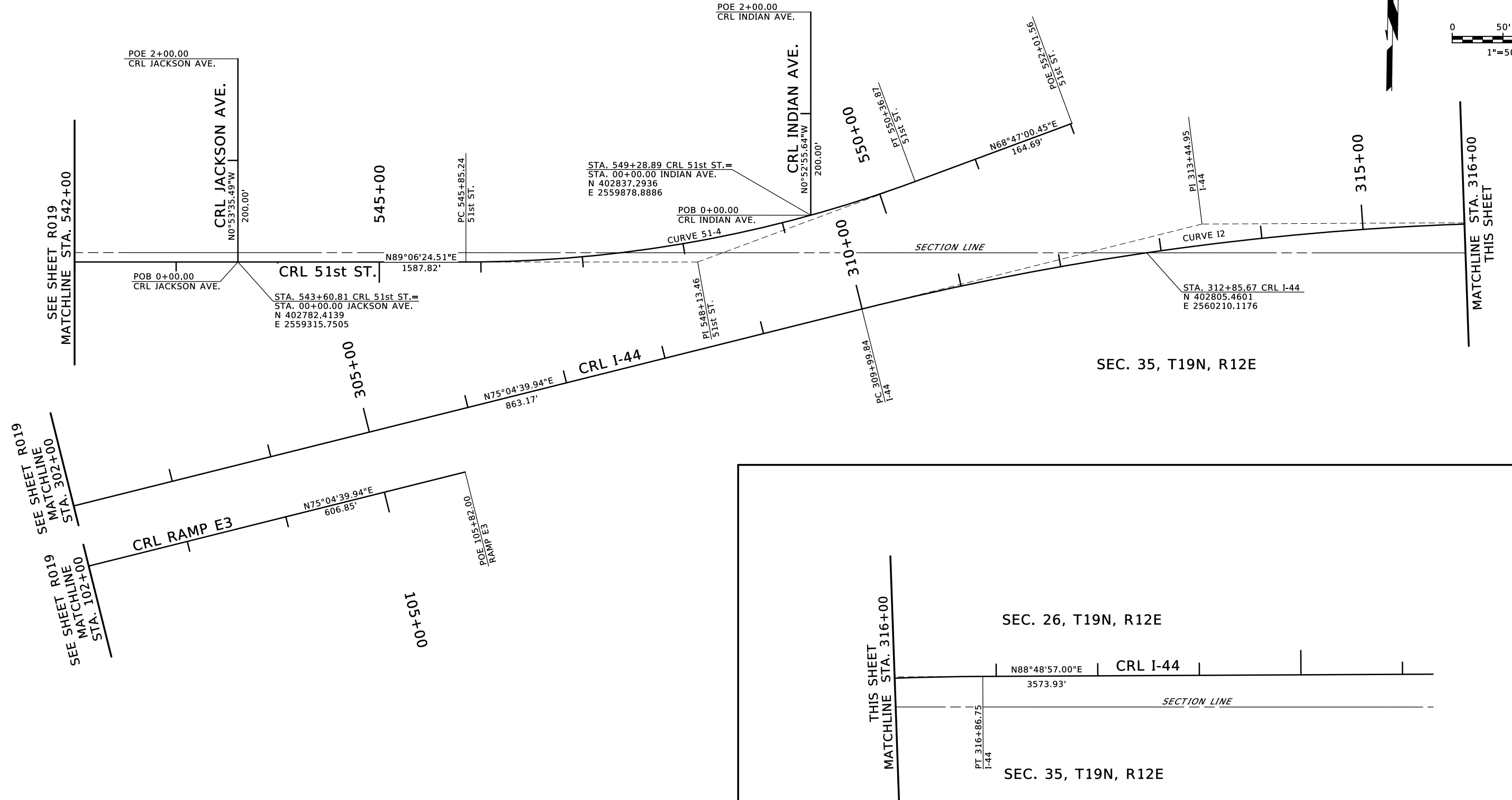

DESIGN		OKLAHOMA DEPARTMENT OF TRANSPORTATION
DRAWN		
CHECKED		
APPROVED		
SQUAD		
GEOMETRIC DATA (8)		
COUNTY - TULSA		HIGHWAY US-75 STATE JOB NO. 33788(11) SHEET NO R020

SEC. 26, T19N, R12E

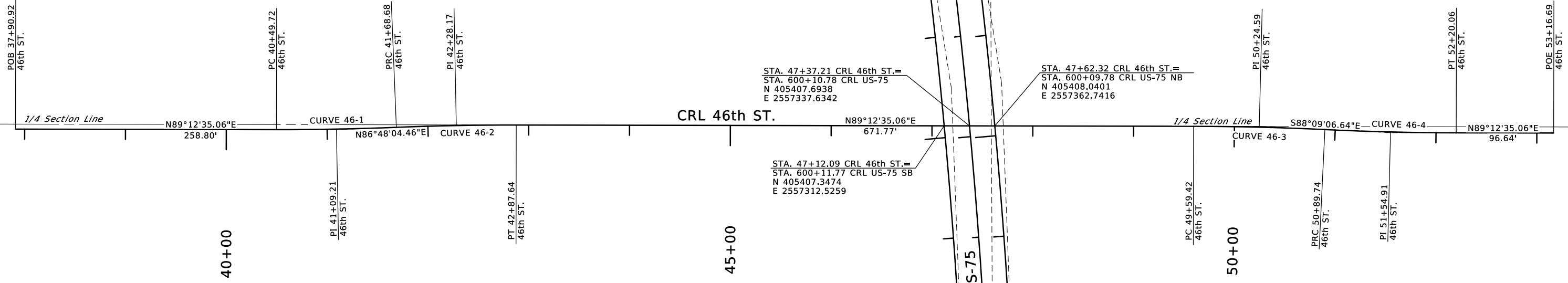
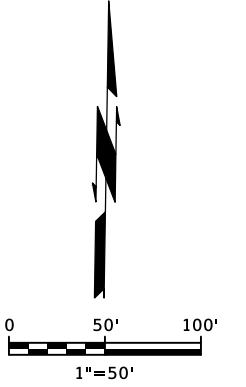

SEE SHEET R016 FOR US 75 GEOMETRIC DATA

DESIGN		OKLAHOMA DEPARTMENT OF TRANSPORTATION
DRAWN		GEOMETRIC DATA (9)
CHECKED		
APPROVED		
SQUAD		
COUNTY TULSA		HIGHWAY US-75 STATE JOB NO. 33788(11) SHEET NO. R021

R/W UTILITY MEETING

MARCH 2021

3/4/2021

CRL US-75

CURVE NO	STATION	CARDINAL POINTS		CURVE DATA					SUPERELEVATION				
		X (EASTING) (feet)	Y (NORTHING) (feet)	DELTA	DEGREE	RADIUS (feet)	TANGENT (feet)	ARC LENGTH (feet)	EXTERNAL (feet)	DESIGN SPEED (mph)	e _{max} (ft/ft)	S (ft/ft)	
U1	POB	500+00.00	2557563.9336	395400.0832	19°37'14.04" LT	1°00'00.00"	5729.578	990.729	1962.057	85.025	65	0.06	0.03
	PC	595+11.78	2557369.5306	404909.8769									
	PI	605+02.51	2557349.2820	405900.3990									
	PT	614+73.84	2556997.6019	406826.6091									
	POE	640+72.49	2556075.1539	409256.0350									

CRL I-44

CURVE NO	STATION	CARDINAL POINTS		CURVE DATA					SUPERELEVATION				
		X (EASTING) (feet)	Y (NORTHING) (feet)	DELTA	DEGREE	RADIUS (feet)	TANGENT (feet)	ARC LENGTH (feet)	EXTERNAL (feet)	DESIGN SPEED (mph)	e _{max} (ft/ft)	S (ft/ft)	
I1	POB	200+00.00	2548969.7000	402271.5500	14°01'30.00" LT	2°00'00.00"	2864.790	352.39	701.250	21.59	65	0.06	0.05
	PI	216+81.66	2550651.1500	402298.2200									
	PC	242+00.00	2553169.2200	402334.5800									
	PT	258+99.80	2554868.7100	402367.3700									
	POE	269+74.61	2555943.3100	402388.6800									
I2	POB	294+35.43	2558403.8200	402427.2100	13°44'17.06" RT	2°00'00.00"	2864.790	345.11	686.9	20.71	65	0.06	0.05
	PI	297+87.81	2558756.1600	402432.7300									
	PC	301+36.68	2559096.6700	402523.4700									
	PT	309+99.84	255930.7200	402745.7500									
	POE	313+44.95	2560264.1900	402834.6100									
I3	POB	316+86.75	2560609.2200	402841.7500	7°26'05.74" RT	1°30'00.00"	3819.720	248.180	495.66	8.05	65	0.06	0.042
	PI	352+60.68	2564182.3900	402915.6100									
	PC	355+08.86	2564430.5200	402920.7300									
	PT	357+56.34	2564677.2200	402893.7100									
	POE	360+47.16	2564966.3100	402862.0500									
I4	POB	362+95.65	2565213.3200	402834.9900	7°26'39.15" LT	1°30'00.00"	3819.72	248.49	496.28	8.07	65	0.06	0.042
	PI	365+43.44	2565461.7600	402840.1700									
	PC	400+76.49	2568994.0500	402913.7600									
	PT	405+43.36	2569460.8100	402923.4800									
	POE	410+08.18	2569919.8900	403008.3800									
I5	POB	419+34.74	2570831.0100	403176.8800	9°17'03.97" LT	0°59'47.48"	5749.58	466.86	931.68	18.92	65	0.06	NC
	PI	422+42.53	2571133.6600	403232.8600									
	PC	422+42.53	2571133.6600	403232.8600									
	PT	422+42.53	2571133.6600	403232.8600									
	POE	425+48.97	2571441.3800	403239.3900									
I6	POB	425+48.97	2571441.3800	403239.3900	9°15'43.10" RT	1°30'28.42"	3799.72	307.79	614.23	12.45	65	0.06	0.042
	PI	425+48.97	2571441.3800	403239.3900									
	PC	425+48.97	2571441.3800	403239.3900									
	PT	425+48.97	2571441.3800	403239.3900									
	POE	425+48.97	2571441.3800	403239.3900									

CRL RAMP E2

CURVE NO	STATION	CARDINAL POINTS		CURVE DATA					SUPERELEVATION				
		X (EASTING) (feet)	Y (NORTHING) (feet)	DELTA	DEGREE	RADIUS (feet)	TANGENT (feet)	ARC LENGTH (feet)	EXTERNAL (feet)	DESIGN SPEED (mph)	e _{max} (ft/ft)	S (ft/ft)	
E2-1	PC	65+47.76	402596.1288	2558601.6552	4°46'07.65" RT	2°47'01.98"	2058.125	85.700	171.300	1.783	60	0.06	0.054
	PI	66+33.46	402609.0517	255885.16357									
	PT	67+19.06	402628.9729	2558433.5837									
E2-2	PC	69+76.12	402688.7272	2558183.5675	70°05'59.33" RT	6°44'26.45"	850.000	596.280	1039.952	188.292	45	0.06	0.054
	PI	75+72.40	402827.3355	2557603.6208									
	PT	80+16.07	403419.8317	2557536.5486									
E2-3	PC	84+40.90	403841.9690	2557488.7614	5°17'14.81" RT	1°00'00.00"	5729.578	264.560	528.745	6.105	50	0.06	NC
	PI	87+05.46	404104.8501	2557459.0026									
	PT	89+69.65	404369.3549	2557453.5955									
POE	95+11.78	404911.3689	2557442.5154										

CRL RAMP E3

CURVE NO	STATION	CARDINAL POINTS		CURVE DATA					SUPERELEVATION				
		X (EASTING) (feet)	Y (NORTHING) (feet)	DELTA	DEGREE	RADIUS (feet)	TANGENT (feet)	ARC LENGTH (feet)	EXTERNAL (feet)	DESIGN SPEED (mph)	e _{max} (ft/ft)	S (ft/ft)	
E3-1	POB	72+68.94	2557296.8149	403480.0579	4°05'41.89" RT	1°00'00.00"	5729.578	204.836	409.497	3.660	50	0.06	NC
	PC	73+68.95	2557298.8587	403380.0667									
	PI	75+73.79	2557303.0447	403175.2738									
E3-2	PC	77+78.45	2557292.5958	402970.7048	100°38'46.76" LT	11°27'32.96"	500.000	602.748	878.305	283.138	40	0.06	0.06
	PI	79+75.91	2557282.5232	402773.5021									
	PT	88+54.21	2557849.0585	402252.5311									
E3-3	PC	96+55.16	2558642.7362	402360.1556	7°11'59.66" LT	2°15'00.00"	2546.479	160.209	319.996	5.035	60	0.06	0.05
	PI	98+15.36	2558801.4920	402381.6832									
	PT	99+75.15	2558956.2980	402422.9383									
POE	105+82.00	2559542.6798	402579.2061										

CRL RAMP E4

CURVE NO	STATION	CARDINAL POINTS		CURVE DATA					SUPERELEVATION				
		X (EASTING) (feet)	Y (NORTHING) (feet)	DELTA	DEGREE	RADIUS (feet)	TANGENT (feet)	ARC LENGTH (feet)	EXTERNAL (feet)	DESIGN SPEED (mph)	e _{max} (ft/ft)	S (ft/ft)	
E4-1	POB	165+03.25	2556270.0496	402504.3106	90°16'25.47" LT	6°00'00.00"	954.930	959.503	1504.562	398.783	50	0.06	0.06
	PC	165+78.25	2556345.0404	402505.4851									
	PI	175+37.75	2557304.4258	402520.5100									
E4-2	PC	180+82.81	2557284.8174	403479.8126	2°59'59.57" RT	0°30'00.00"	11459.156	300.057	599.976	3.928	60	0.06	NC
	PI	182+18.16	2557282.0514	403615.1335									
	PT	185+18.22	2557275.9194	403915.1274									
POE	188+18.14	2557285.4957	404215.0310										

CRL RAMP E5

CURVE NO	STATION	CARDINAL POINTS		CURVE DATA					SUPERELEVATION				
		X (EASTING) (feet)	Y (NORTHING) (feet)	DELTA	DEGREE	RADIUS (feet)	TANGENT (feet)	ARC LENGTH (feet)	EXTERNAL (feet)	DESIGN SPEED (mph)	e _{max} (ft/ft)	S (ft/ft)	
E5-1	POB	83+00.00	2557269.4900	402348.4400	35°51'13.79" RT	19°05'54.94"	300.000	97.05	187.730	15.31	25	0.06	0.05
	PC	85+85.12	2557554.5800	402352.9100									
	PI	86+82.18	2557651.6200	402354.4300									
E5-2	PC	87+72.85	2557731.1600	402298.8200	91°23'25.94" RT	27°17'01.34"	210.000	215.16	334.960	90.66	25	0.06	0.058
	PI	89+88.01	2557907.5000	402175.5400									
	PT	91+07.82	2557779.9800	402002.2400									
E5-3	PC	95+64.19	2557509.5000	401634.6600	142°28'54.36" RT	36°57'54.07"	155.000	456.38	385.450	326.980	25	0.06	0.06
	PI	94+93.27	2557500.1700	402090.9400									
	PT	97+00.00	2557495.9500	402297.6300									

CRL RAMP E8

CURVE NO	STATION	CARDINAL POINTS		CURVE DATA					SUPERELEVATION				
		X (EASTING) (feet)	Y (NORTHING) (feet)	DELTA	DEGREE	RADIUS (feet)	TANGENT (feet)	ARC LENGTH (feet)	EXTERNAL (feet)	DESIGN SPEED (mph)	e _{max} (ft/ft)	S (ft/ft)	
E8-1	POB	57+45.89	2557538.3227	401146.7825	92°43'34.10" LT	10°30'00.00"	545.674	572.275	883.106	245.059	40	0.06	0.06
	PC	65+25.37	2557563.1996	401925.8618									
	PI	70+97.64	2557581.4637	402497.8454									
E8-2	PC	74+08.47	2557009.2587	402488.8841	4°12'25.82" LT	0°40'00.00"	8594.367	315.680	631.076	5.796	40	0.06	NC
	PI	84+21.23	2555996.6279	402473.0252									
	PT	87+36.91	2555680.9869	402468.0820									
E8-3	PC	90+52.30	2555366.5591	402439.9957	3°58'06.80" RT	1°00'00.00"	5729.578	198.507	396.855	3.438	40	0.06	NC
	PI	92+50.81	2555168.8393	402422.3343									
	PT	94+49.16	2554970.3712	402418.3993									
POE	95+51.79	2554867.7636	402416.3649										

CRL RAMP Z

CURVE NO	STATION	CARDINAL POINTS		CURVE DATA					SUPERELEVATION				
		X (EASTING) (feet)	Y (NORTHING) (feet)	DELTA	DEGREE	RADIUS (feet)	TANGENT (feet)	ARC LENGTH (feet)	EXTERNAL (feet)	DESIGN SPEED (mph)	e _{max} (ft/ft)	S (ft/ft)	
Z1	POB	617+00.00	2556860.2932	407016.3903	17°34'02.98" LT	4°15'00.00"	1348.136	208.311	413.353	15.999	60	0.06	0.06
	PC	619+47.84	2556772.3172	407248.0903									
	PI	621+56.15	2556698.3728	407442.8355									
	PT	623+61.19	2556569.0974	407606.1795									
	POE	625+71.73	2556438.4385	407771.2716									

CRL W 46TH ST

CURVE NO	STATION	CARDINAL POINTS		CURVE DATA					SUPERELEVATION			
		X (EASTING) (feet)	Y (NORTHING) (feet)	DELTA	DEGREE	RADIUS (feet)	TANGENT (feet)	ARC LENGTH (feet)	EXTERNAL (feet)	DESIGN SPEED (mph)	e _{max} (ft/ft)	S (ft/ft)
46-1	POB	37+90.92	2556391.5811	405389.6439	2°24'30.59" LT	2°01'28.51"	2830.000	59.490	118.963	0.625	25	NC
	PC	40+49.72	2556550.3530	405393.2132								
	PI	41+09.21	2556709.8374	405394.0337								
46-2	PC	41+68.68	2									

R/W UTILITY MEETING

MARCH 2021

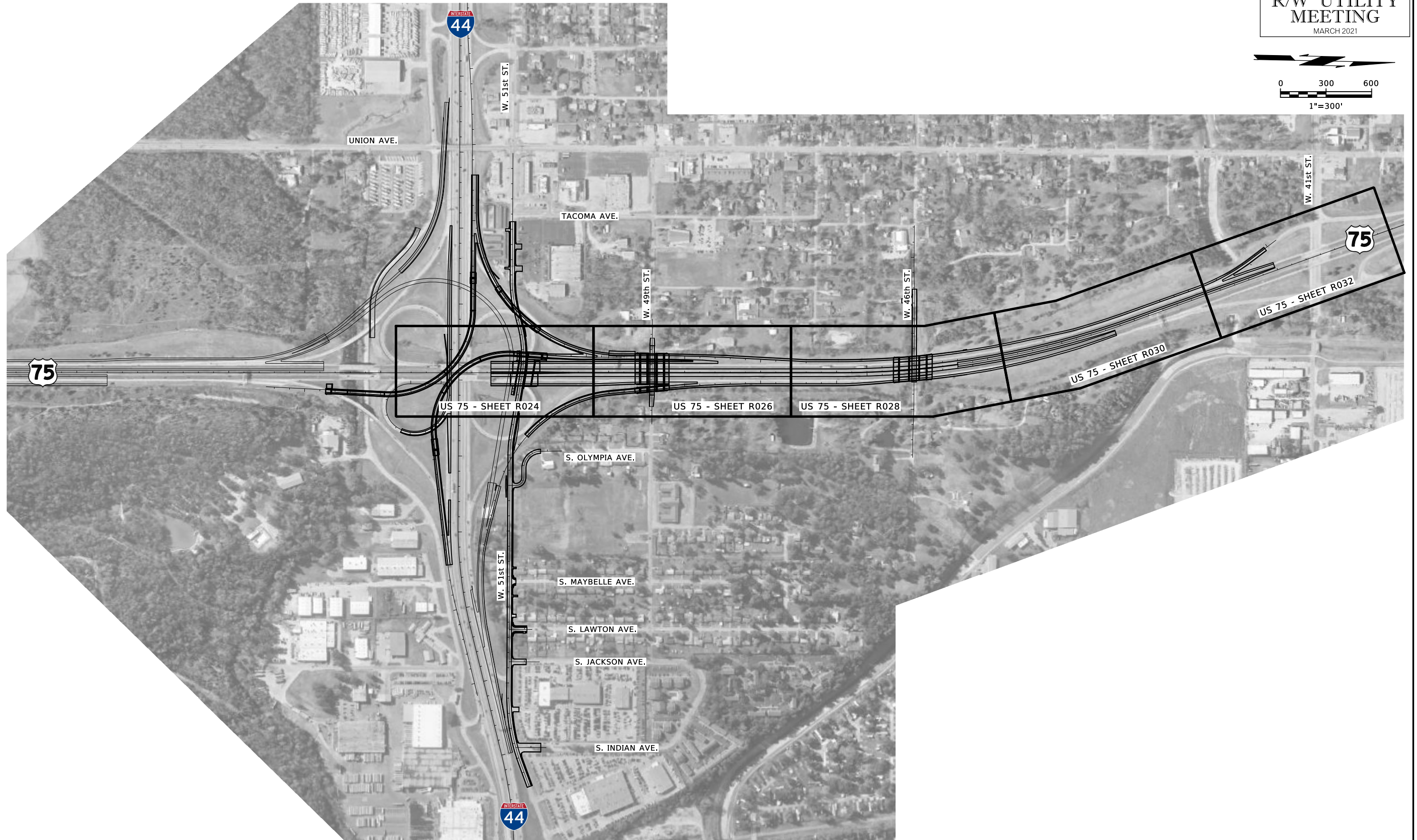
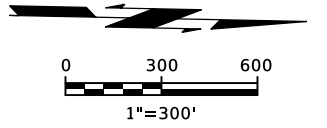

DESIGN	
DRAWN	
CHECKED	
APPROVED	
SQUAD	

OKLAHOMA DEPARTMENT OF TRANSPORTATION

PLAN KEY MAP (MAINLINE)

UTILITY COMPANY OWNER'S LIST	
PSO	918-250-6211
COX	405-417-4064
AT&T	918-596-4237
ONG	405-556-6401
CITY OF TULSA	918-596-2595
ONEOK Field services	918-588-7431
Phillips 66	918-977-5143
Enable Midstream	405-921-3582
Enbridge Energy	918-223-2054

SEC. 35, T19N, R12E

SEC. 26, T19N, R12E

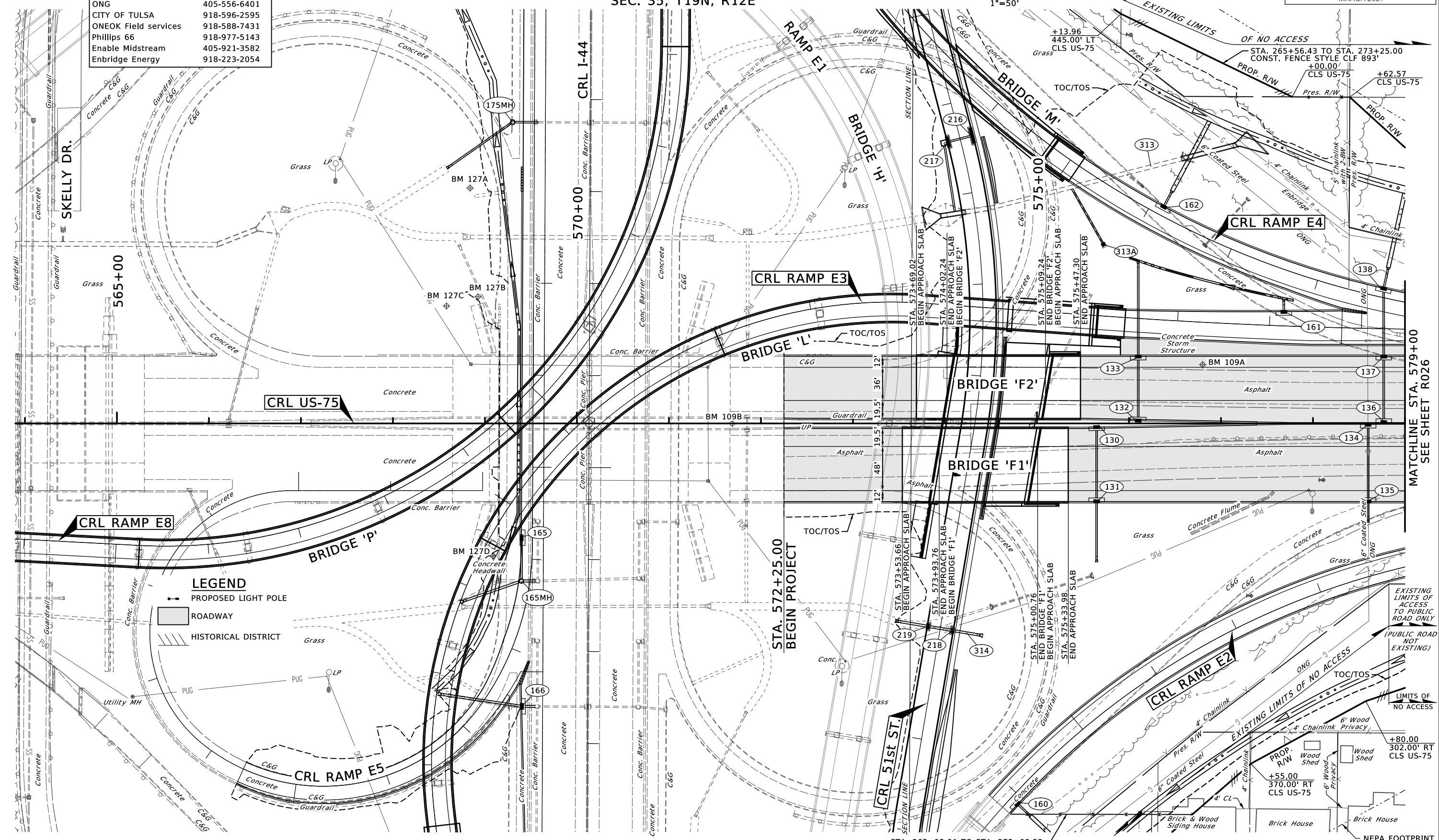
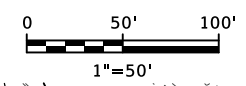

LEGEND

- PROPOSED LIGHT POLE
- ROADWAY
- HISTORICAL DISTRICT

BENCHMARK 127A
 CUT X ON HEADWALL
 STA. 117+97.08, 130.61' RT CLS I-44
 STA. 119+15.21, 121.49' RT CLS I-44
 STA. 281+96.89, 130.55' RT CRL I-44
 N 402277.28, E 2557167.48, EL. 647.773

BENCHMARK 127B
 CUT X ON WEST ENDHEADWALL
 STA. 119+25.36, 155.62' RT CLS I-44
 STA. 283+15.01, 121.43' RT CRL I-44
 N 402288.26, E 2557285.45, EL. 645.844

BENCHMARK 127C
 CUT X ON CL HEADWALL
 STA. 119+25.36, 155.62' RT CLS I-44
 STA. 283+25.17, 155.56' RT CRL I-44
 N 402254.29, E 2557296.14, EL. 645.458

BENCHMARK 127D
 CUT X ON HEADWALL
 STA. 121+96.90, 103.87' RT CLS I-44
 STA. 285+96.71, 103.79' RT CRL I-44
 N 402310.30, E 2557566.83, EL. 649.568

STA. 265+93.81 TO STA. 273+08.53
 CONST. FENCE STYLE CLF 813'

BENCHMARK 109B
 CUT BOX
 STA. 262+91.38, 0.32' RT CLS US-75
 STA. 571+68.83, 0.16' RT CRL US-75
 N 402567.42, E 2557417.57, EL. 675.341

BENCHMARK 109A
 CUT X
 STA. 268+02.61, 63.73' LT CLS US-75
 STA. 576+80.06, 63.89' LT CRL US-75
 N 403077.23, E 2557343.09, EL. 684.871

MATCHLINE STA. 579+00
SEE SHEET R026

R/W UTILITY MEETING

MARCH 2021

3/4/2021

BENCHMARK 127A
CUT X ON HEADWALL
STA. 117+97.08, 130.61' RT CLS I-44
STA. 281+96.89, 130.55' RT CRL I-44
N 402277.28, E 2557167.48, EL. 647.773

BENCHMARK 127B
CUT X ON WEST ENDHEADWALL
STA. 119+15.21, 121.49' RT CLS I-44
STA. 283+15.01, 121.43' RT CRL I-44
N 402288.26, E 2557285.45, EL. 645.844

BENCHMARK 127C
CUT X ON CL HEADWALL
STA. 119+25.36, 155.62' RT CLS I-44
STA. 283+25.17, 155.56' RT CRL I-44
N 402254.29, E 2557296.14, EL. 645.458

BENCHMARK 127D
CUT X ON HEADWALL
STA. 121+96.90, 103.87' RT CLS I-44
STA. 285+96.71, 103.79' RT CRL I-44
N 402310.30, E 2557566.83, EL. 649.568

BENCHMARK 109B
CUT BOX
STA. 262+91.38, 0.32' RT CLS US-75
STA. 571+68.83, 0.16' RT CRL US-75
N 402567.42, E 2557417.57, EL. 675.341

BENCHMARK 109A
CUT X
STA. 268+02.61, 63.73' LT CLS US-75
STA. 576+80.06, 63.89' LT CRL US-75
N 403077.23, E 2557343.09, EL. 684.871

LEGEND

- PROPOSED GRADE
- - - EXISTING GRADE AT CRL
- · - · EXISTING GRADE AT PGL (RT)
- · - · EXISTING GRADE AT PGL (LT)

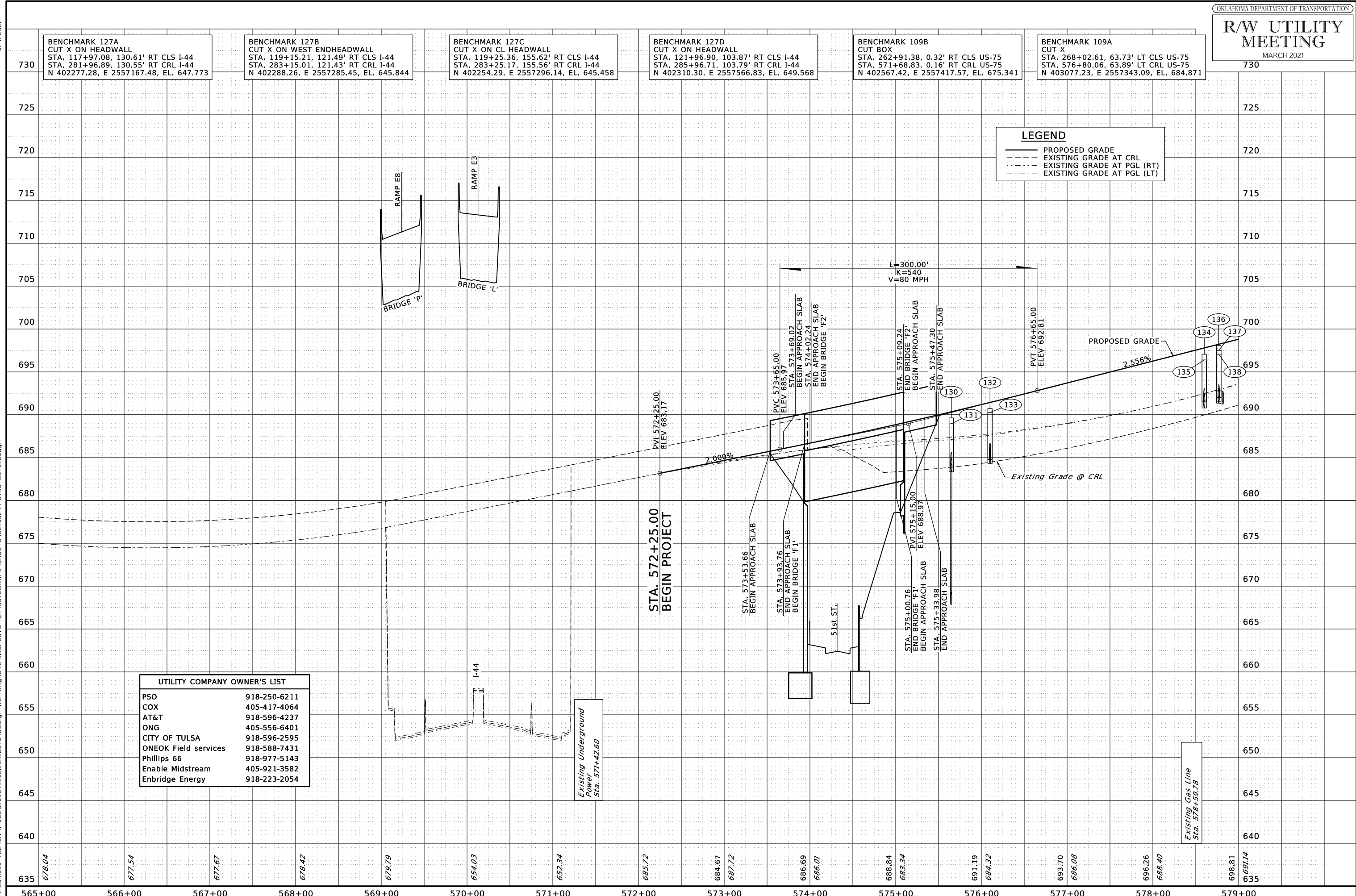

UTILITY COMPANY OWNER'S LIST

PSO	918-250-6211
COX	405-417-4064
AT&T	918-596-4237
ONG	405-556-6401
CITY OF TULSA	918-596-2595
ONEOK Field services	918-588-7431
Phillips 66	918-977-5143
Enable Midstream	405-921-3582
Enbridge Energy	918-223-2054

P:\FDB\650-TUL\CIV\400315_0001_EC2123A_US75\Design-Work\King\CIV\MicroStation\3378811\Profile US75_01.dgn

SEC. 35, T19N, R12E

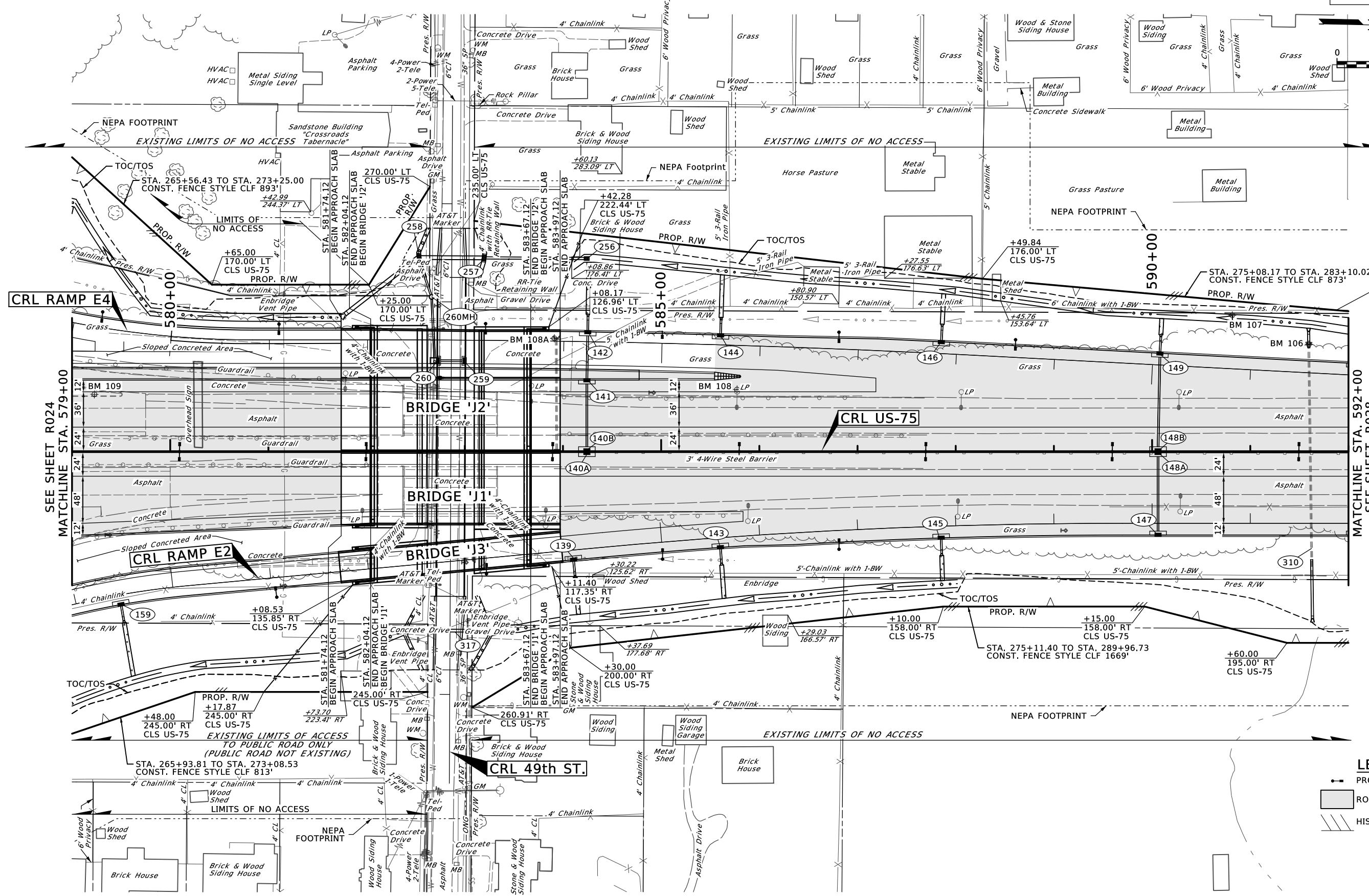
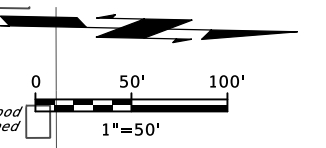

SEE SHEET R024
MATCHLINE STA. 579+00

MATCHLINE STA. 592+00
SEE SHEET R028

BENCHMARK 108A
CUT X
STA. 275+13.76, 115.40' LT CLS US-75
STA. 583+91.21, 115.56' LT CRL US-75
N 403787.17, E 2557276.90, EL. 682.821

BENCHMARK 108
3/8IPIC
STA. 276+99.78, 63.16' LT CLS US-75
STA. 585+77.23, 63.32' LT CRL US-75
N 403974.23, E 2557325.32, EL. 706.998

BENCHMARK 107
5/8IP ALUM CAP
STA. 282+04.18, 138.73' LT CLS US-75
STA. 590+81.63, 138.89' LT CRL US-75
N 404476.97, E 2557239.46, EL. 701.479

BENCHMARK 106
CUT X
STA. 282+82.18, 109.02' LT CLS US-75
STA. 591+59.63, 109.18' LT CRL US-75
N 404555.57, E 2557267.57, EL. 701.263

LEGEND

- PROPOSED LIGHT POLE
- ROADWAY
- HISTORICAL DISTRICT

3/4/2021

P:\FDB\650-TUL\CIV\400315_0001_EC223A-US75\Design-Work\King\CIV\MicroStation\33788\1-Plan-US75_02.dgn

R/W UTILITY MEETING

MARCH 2021

3/4/2021

P:\FDB\1650-TUL\CIV\1400315_0001_EC2123A_US75\Design-Working\CIV\MicroStation\3378811\WPS\Sheets\3378811-Profile US75_02.dgn

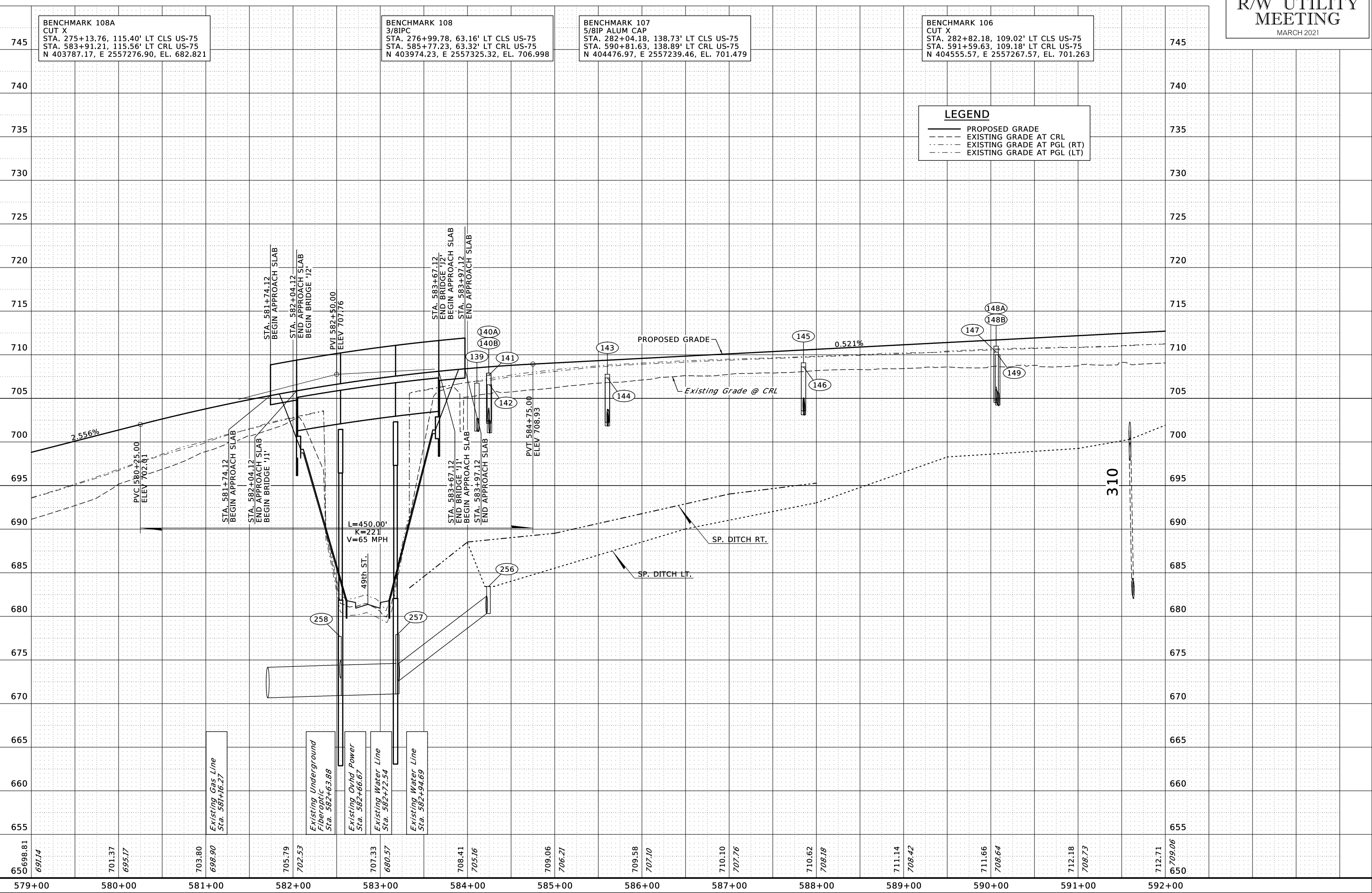

LEGEND

- PROPOSED GRADE
- - - EXISTING GRADE AT CRL
- · · EXISTING GRADE AT PGL (RT)
- · - EXISTING GRADE AT PGL (LT)

SEC. 35, T19N, R12E

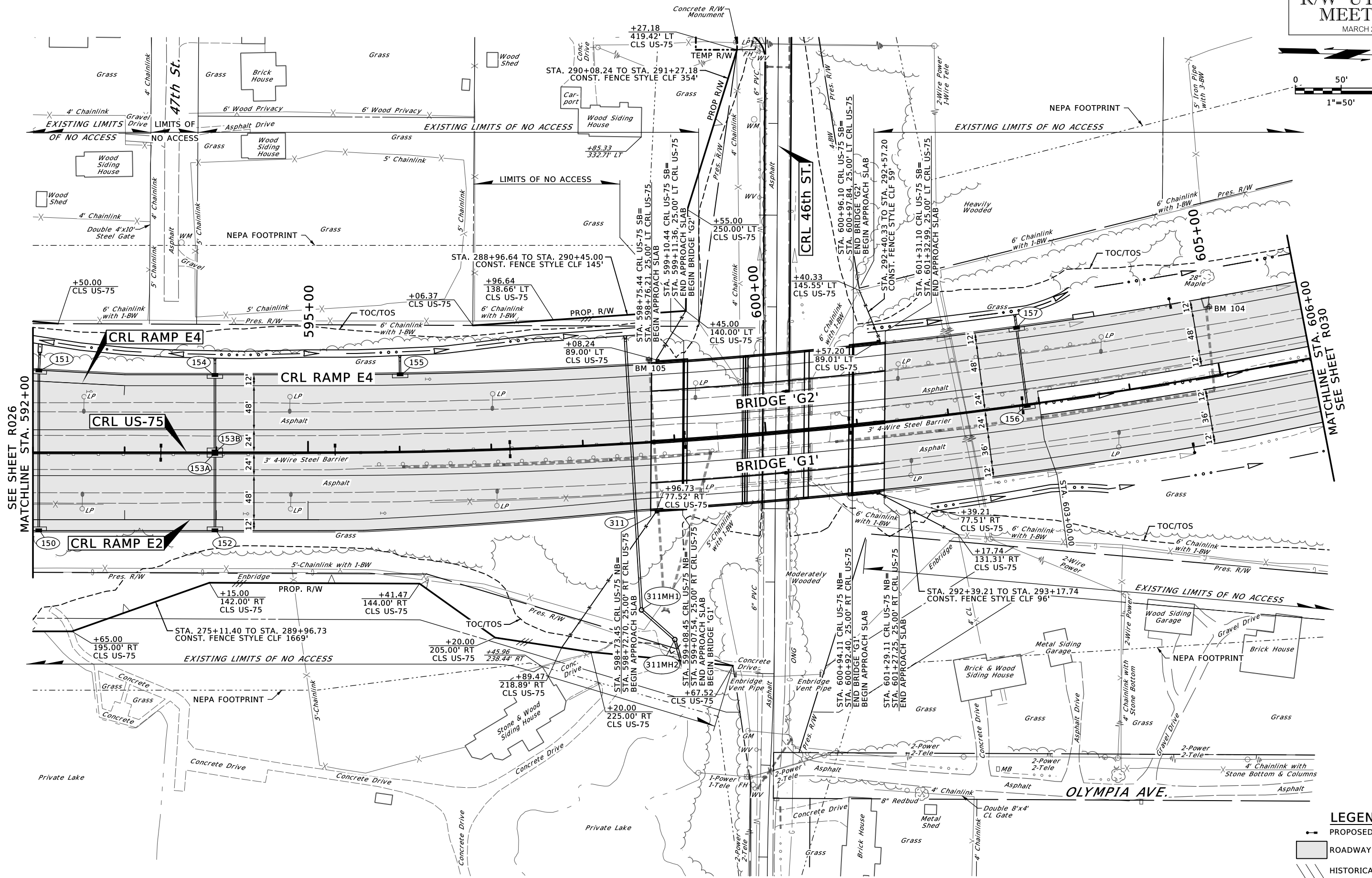
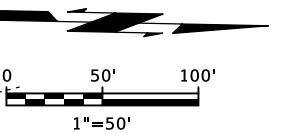

SEE SHEET R026
MATCHLINE STA. 592+00

MATCHLINE STA. 606+00
SEE SHEET R030

BENCHMARK 105
 CUT X
 STA. 290+00.39, 89.22' LT CLS US-75
 STA. 598+77.83, 89.44' LT CRL US-75
 N 405267.83, E 2557261.24, EL. 706.515

BENCHMARK 104
 CUT X
 STA. 296+23.28, 74.83' LT CLS US-75
 STA. 605+00.76, 75.15' LT CRL US-75
 N 405877.59, E 2557190.54, EL. 700.966

- LEGEND**
- PROPOSED LIGHT POLE
 - ▭ ROADWAY
 - ▨ HISTORICAL DISTRICT

R/W UTILITY MEETING

MARCH 2021

3/4/2021

P:\FDB\650-TUL\CIV\400315_0001_EC2123A_US75\Design-Work\King\CIV\MicroStation\337881-Profile US75_03.dgn

BENCHMARK 105
CUT X
STA. 290+00.39, 89.22' LT CLS US-75
STA. 598+77.83, 89.44' LT CRL US-75
N 405267.83, E 2557261.24, EL. 706.515

BENCHMARK 104
CUT X
STA. 296+23.28, 74.83' LT CLS US-75
STA. 605+00.76, 75.15' LT CRL US-75
N 405877.59, E 2557190.54, EL. 700.966

LEGEND

- PROPOSED GRADE
- - - EXISTING GRADE AT CRL
- - - EXISTING GRADE AT PGL (RT)
- - - EXISTING GRADE AT PGL (LT)

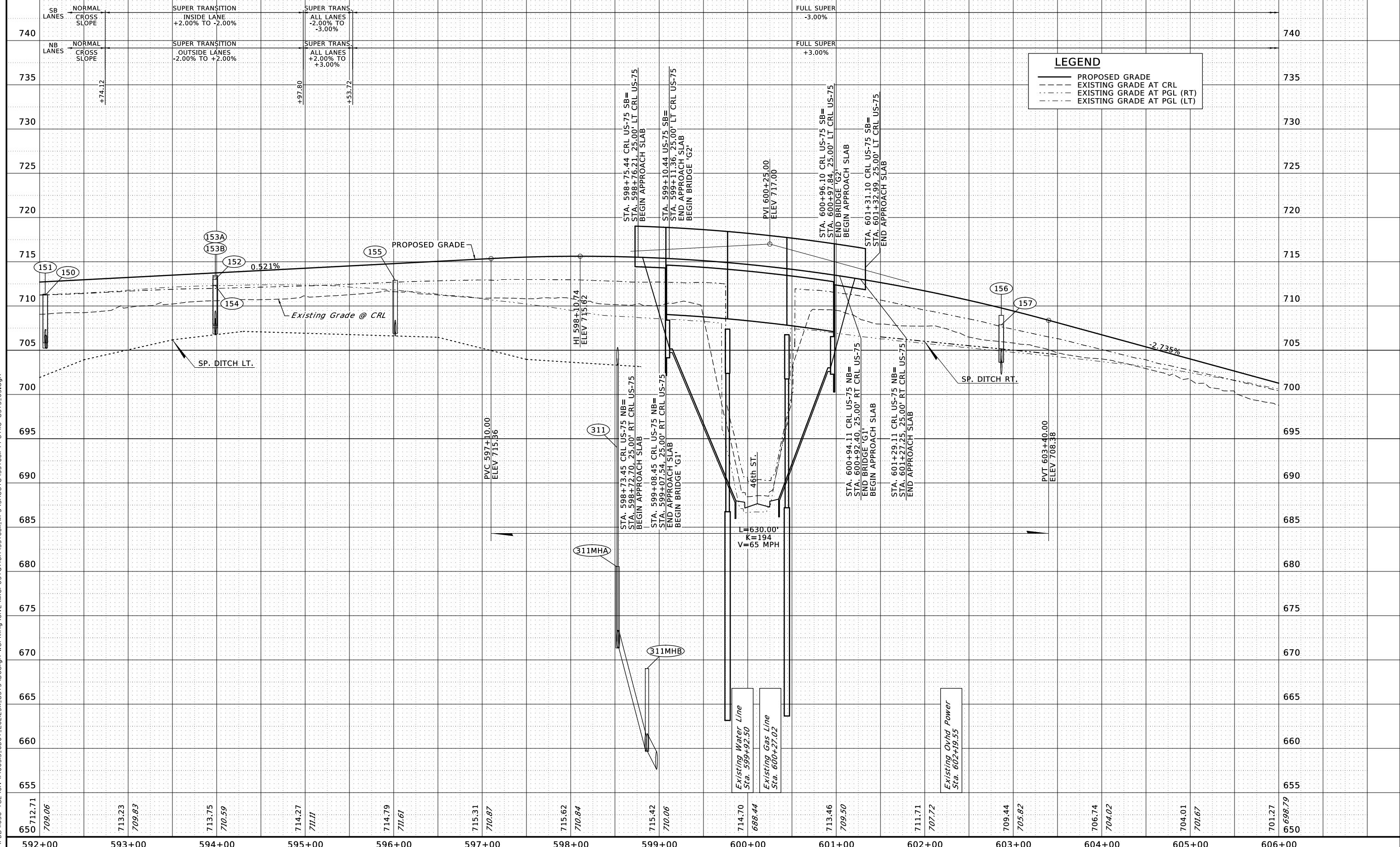

SEC. 26, T19N, R12E

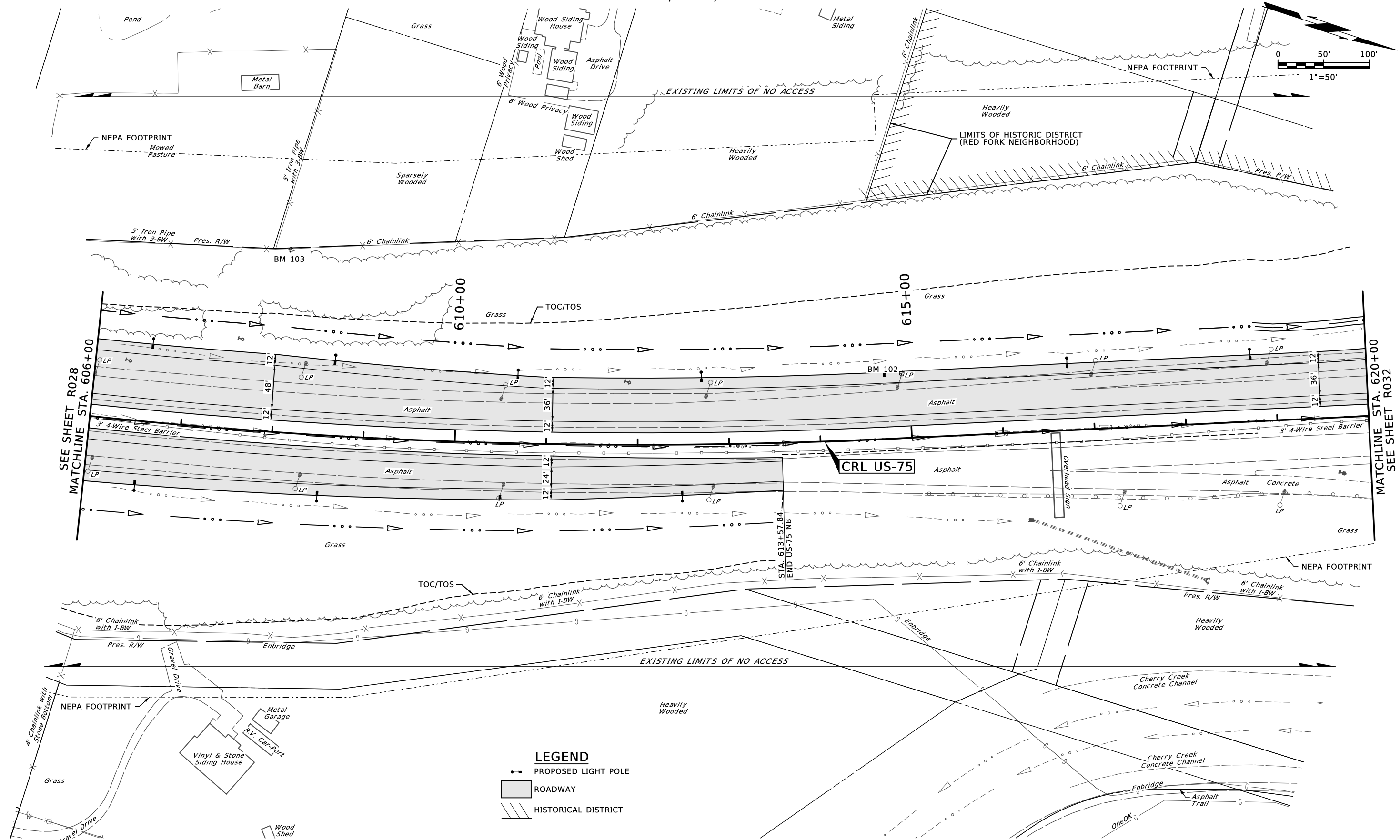
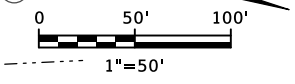

SEE SHEET R028
 MATCHLINE STA. 606+00

MATCHLINE STA. 620+00
 SEE SHEET R032

- LEGEND**
- PROPOSED LIGHT POLE
 - ▭ ROADWAY
 - ▨ HISTORICAL DISTRICT

BENCHMARK 103
 5/8" IP WITH AL CAP
 STA. 299+29.43, 199.97' LT CLS US-75
 STA. 608+06.91, 200.34' LT CRL US-75
 N 406141.88, E 2557003.28, EL. 691.739

BENCHMARK 102
 CUT X
 STA. 306+14.69, 69.92' LT CLS US-75
 STA. 614+92.23, 70.39' LT CRL US-75
 N 406818.82, E 2556925.26, EL. 669.932

3/4/2021
 P:\FDB\650-TUL\CIV\400315_0001_EC2123A_US75\Design-Working\CIV\MicroStation\3378811\WPS\Sheets\3378811-Plan_US75_04.dgn

3/4/2021

BENCHMARK 103
5/8IP WITH AL CAP
STA. 299+29.43, 199.97' LT CLS US-75
STA. 608+06.91, 200.34' LT CRL US-75
N 406141.88, E 2557003.28, EL. 691.739

BENCHMARK 102
CUT X
STA. 306+14.69, 69.92' LT CLS US-75
STA. 614+92.23, 70.39' LT CRL US-75
N 406818.82, E 2556925.26, EL. 669.932

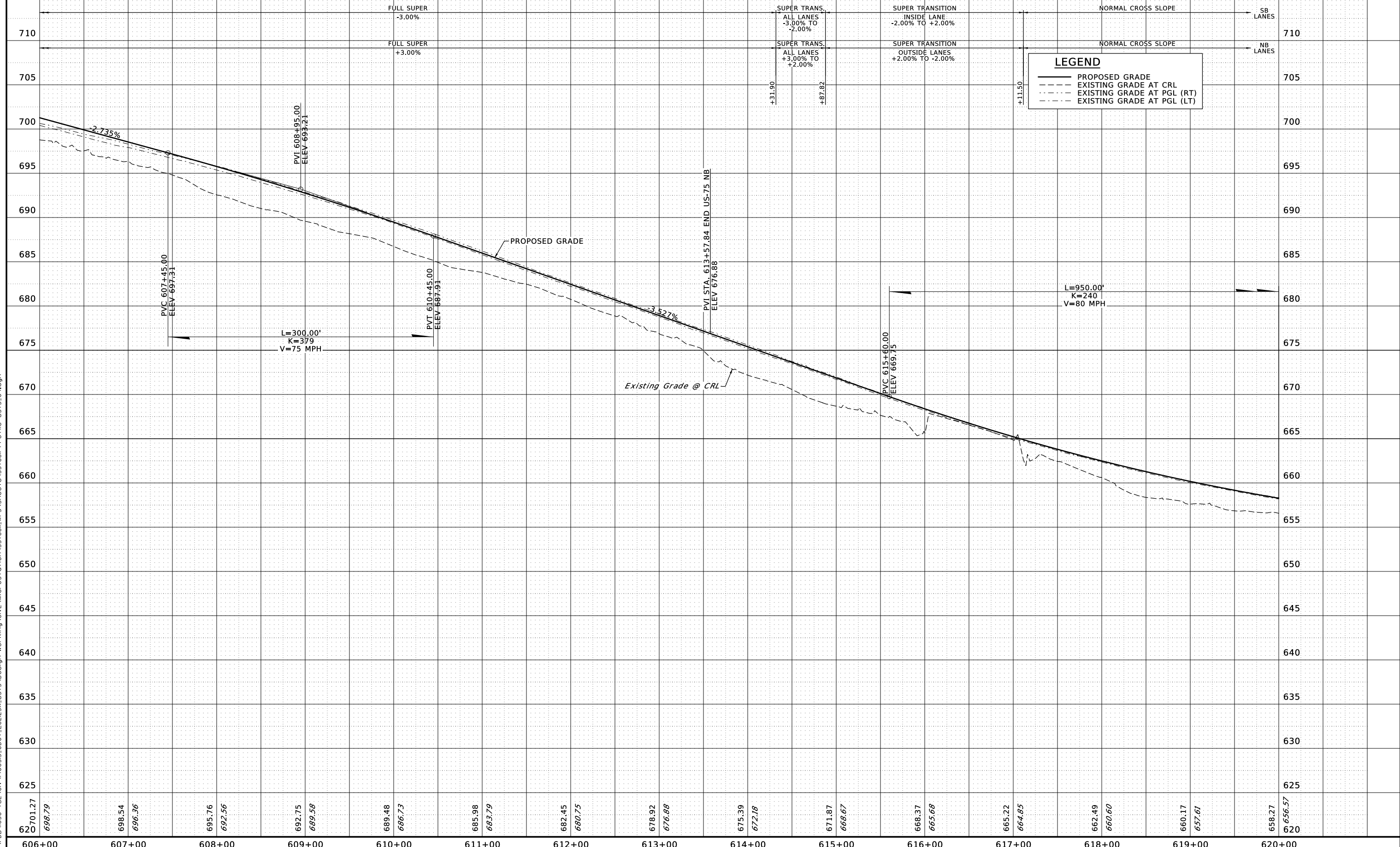

P:\FDB\1650-TUL\CIV\1400315_0001_EC2123A_US75\Design-Working\CIV\MicroStation\3378811\WPS\Sheets\3378811-Profile_US75_04.dgn

SEC. 26, T19N, R12E

SEC. 22, T19N, R12E

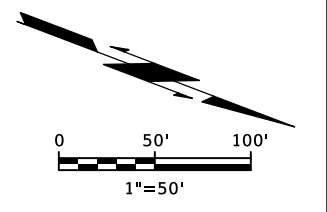

3/4/2021

P:\FDB\650-TUL\CIV\400315_0001_EC2123A_US75\Design-Work\King\CIV\MicroStation\337881\WPS\Sheets\337881-Plan-US75_05.dgn

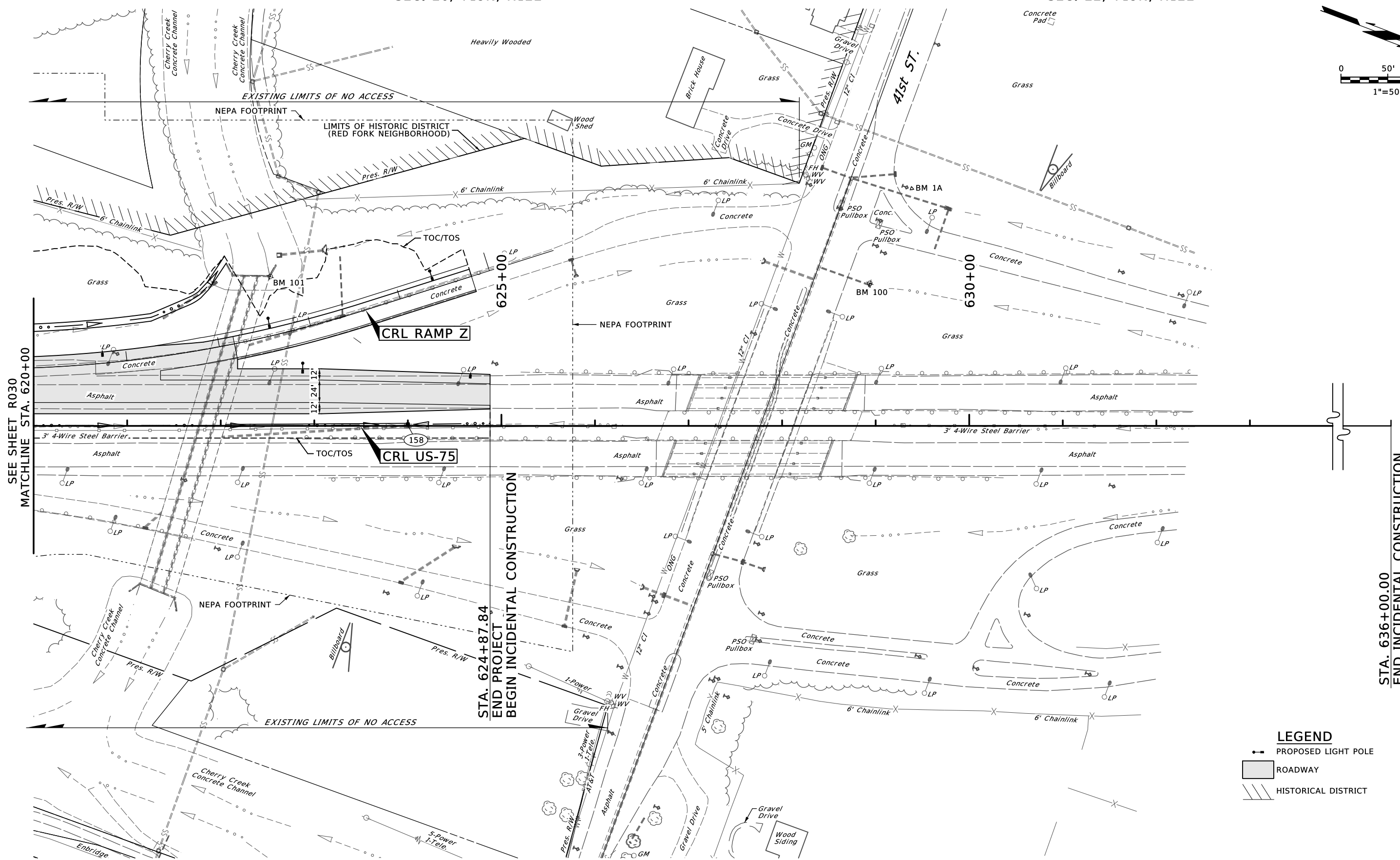

SEE SHEET R030
MATCHLINE STA. 620+00

STA. 636+00.00
END INCIDENTAL CONSTRUCTION

LEGEND

- PROPOSED LIGHT POLE
- ROADWAY
- HISTORICAL DISTRICT

BENCHMARK 101
 CUT X
 STA. 313+75.46, 158.98' LT CLS US-75
 STA. 622+52.99, 159.59' LT CRL US-75
 N 407498.37, E 2556571.82, EL. 631.547

BENCHMARK 100
 CUT X
 STA. 320+16.25, 151.61' LT CLS US-75
 STA. 628+93.78, 152.35' LT CRL US-75
 N 408100.00, E 2556351.14, EL. 634.915

BENCHMARK 1A
 STA. 320+61.09, 252.79' LT CLS US-75
 STA. 629+38.61, 253.53' LT CRL US-75
 N 408105.99, E 2556240.63, EL. 637.82

3/4/2021

P:\FDB\1650-TUL\CIV\1400315_0001_EC2123A_US75\Design-Working\CIV\MicroStation\3378811\WPS\Sheets\3378811-Profile_US75_05.dgn

BENCHMARK 101
CUT X
STA. 313+75.46, 158.98' LT CLS US-75
STA. 622+52.99, 159.59' LT CRL US-75
N 407498.37, E 255671.82, EL. 631.547

BENCHMARK 100
CUT X
STA. 320+16.25, 151.61' LT CLS US-75
STA. 628+93.78, 152.35' LT CRL US-75
N 408100.00, E 2556351.14, EL. 634.915

BENCHMARK 1A
STA. 320+61.09, 252.79' LT CLS US-75
STA. 629+38.61, 253.53' LT CRL US-75
N 408105.99, E 2556240.63, EL. 637.82

LEGEND

- PROPOSED GRADE
- - - EXISTING GRADE AT CRL
- · - · EXISTING GRADE AT PGL (RT)
- · - · EXISTING GRADE AT PGL (LT)

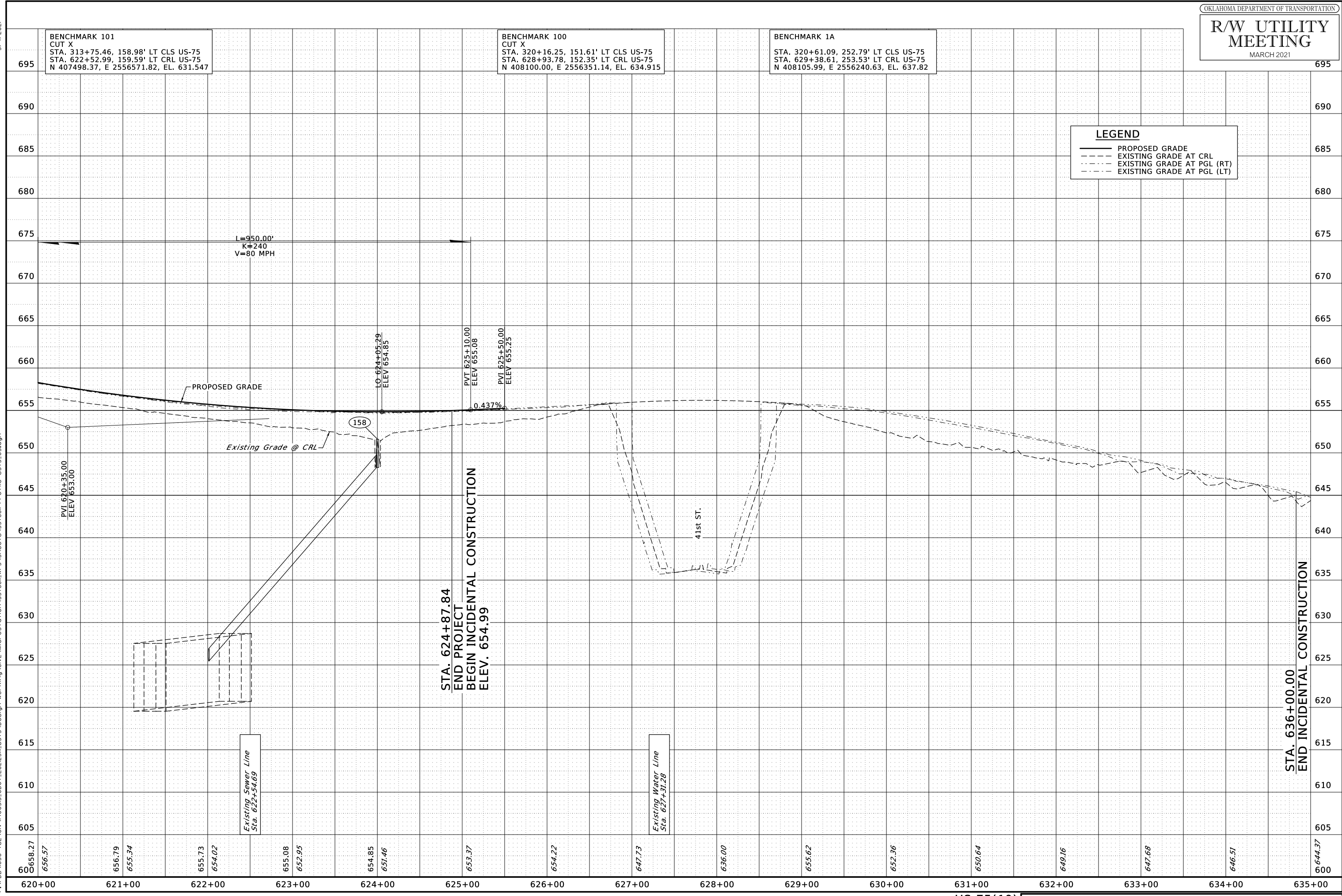

L=950.00'
K=240
V=80 MPH

PROPOSED GRADE

Existing Grade @ CRL

158

LO 624+05.29
ELEV 654.85

PVT 625+10.00
ELEV 655.08

PVI 625+50.00
ELEV 655.25

0.437%

41st ST.

STA. 624+87.84
END PROJECT
BEGIN INCIDENTAL CONSTRUCTION
ELEV. 654.99

STA. 636+00.00
END INCIDENTAL CONSTRUCTION

Existing Sewer Line
Sta. 622+54.69

Existing Water Line
Sta. 627+31.28

6658.27	656.57	656.79	655.34	655.73	654.02	655.08	652.95	654.85	651.46	653.37	654.22	647.73	636.00	655.62	652.36	650.64	649.16	647.68	646.51	644.37
620+00	621+00	622+00	623+00	624+00	625+00	626+00	627+00	628+00	629+00	630+00	631+00	632+00	633+00	634+00	635+00					

R/W UTILITY MEETING

MARCH 2021

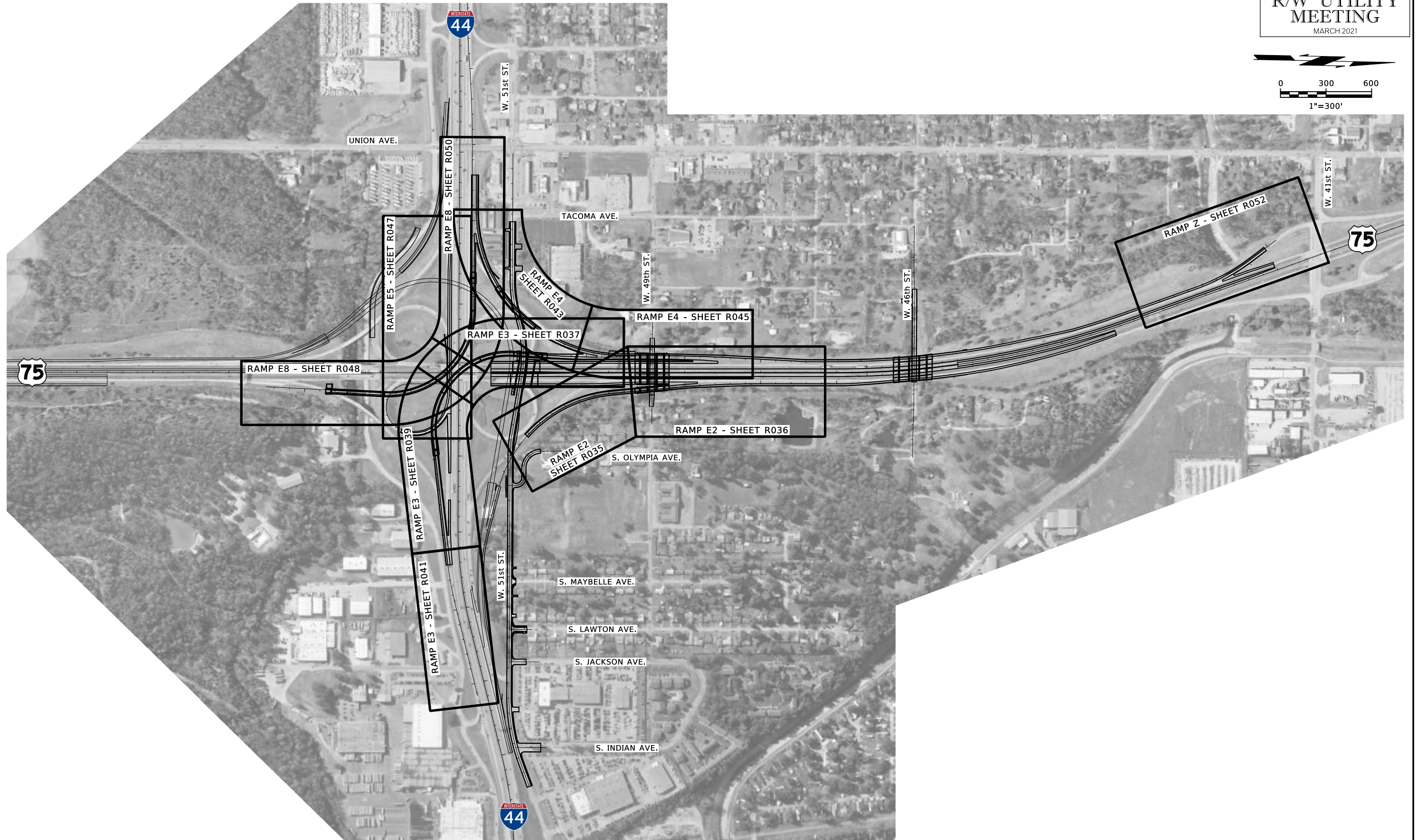
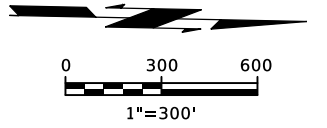

DESIGN		OKLAHOMA DEPARTMENT OF TRANSPORTATION
DRAWN		
CHECKED		
APPROVED		
SQUAD		
PLAN KEY MAP (RAMPS)		
COUNTY	TULSA	HIGHWAY US-75 STATE JOB NO. 33788(11) SHEET NO R034

3/4/2021

P:\FDB\1650-TUL\CIV\1400315_0001_EC2123A-UST5\Design-Work\King\CIV\MicroStation\337881-WPS\Sheets\337881-PnP-Ramp E2_0.dgn

SEC. 35, T19N, R12E

SEC. 26, T19N, R12E

OKLAHOMA DEPARTMENT OF TRANSPORTATION

R/W UTILITY MEETING

MARCH 2021

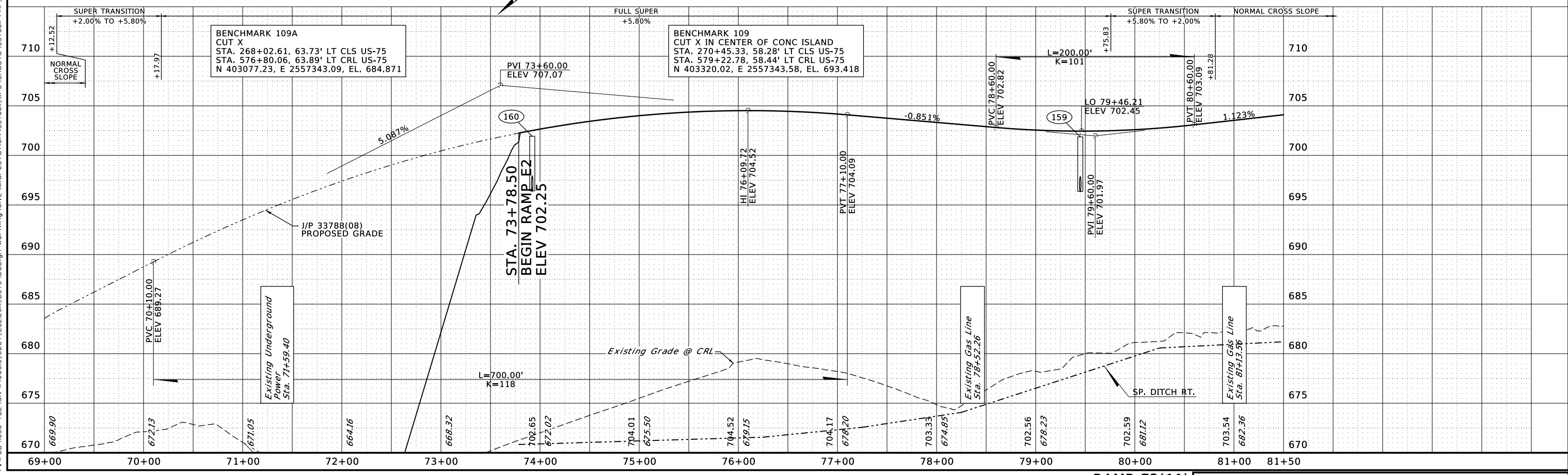
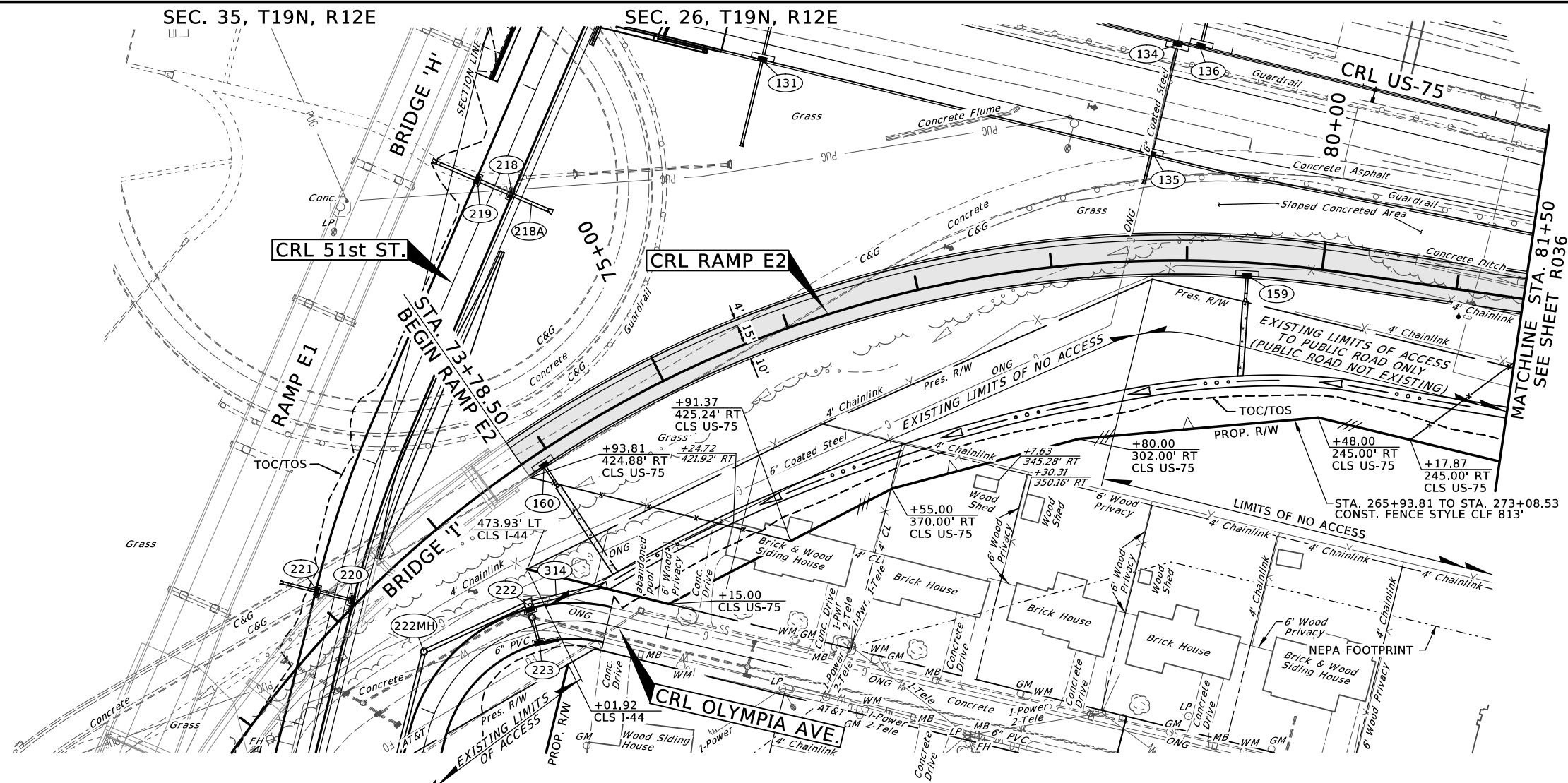
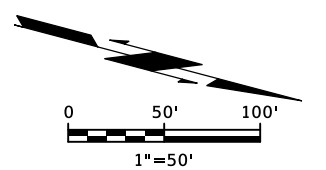

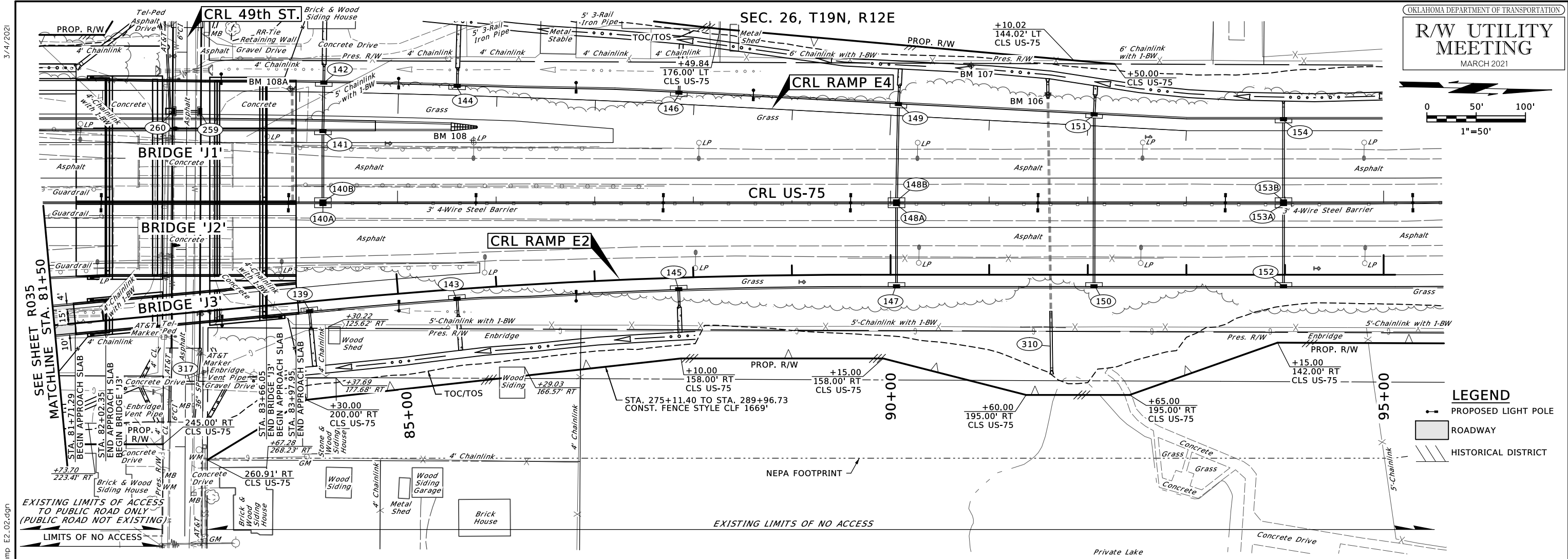
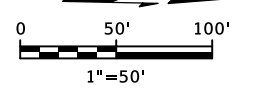

LEGEND

- PROPOSED LIGHT POLE
- ROADWAY
- HISTORICAL DISTRICT

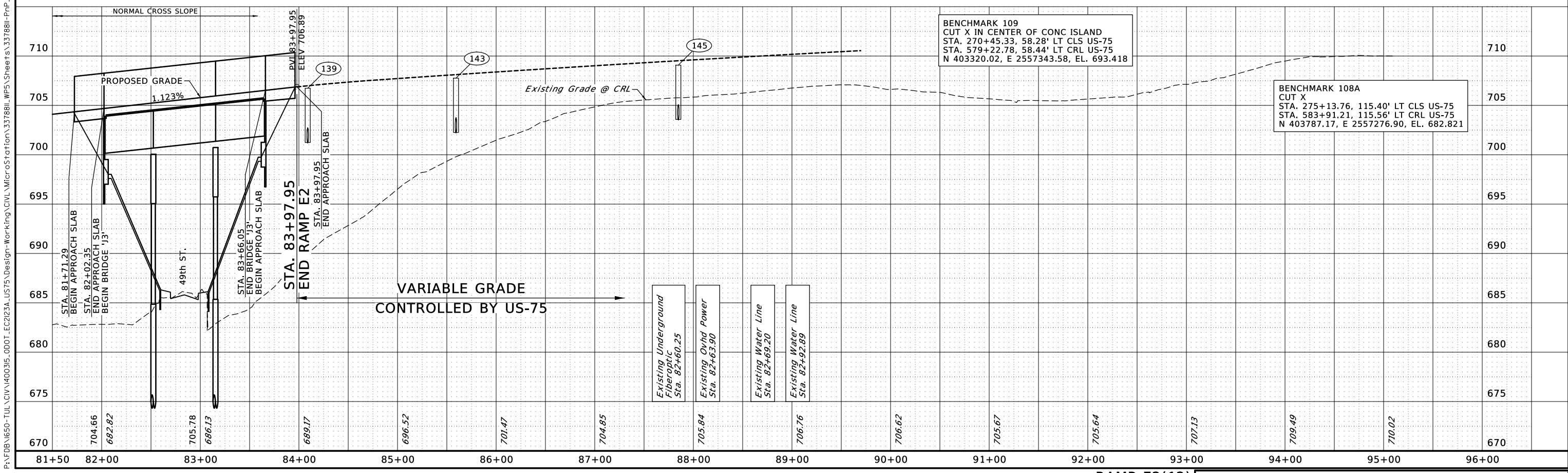

BENCHMARK 109
 CUT X IN CENTER OF CONC ISLAND
 STA. 270+45.33, 58.28' LT CLS US-75
 STA. 579+22.78, 58.44' LT CRL US-75
 N 403320.02, E 2557343.58, EL. 693.418

BENCHMARK 108A
 CUT X
 STA. 275+13.76, 115.40' LT CLS US-75
 STA. 583+91.21, 115.56' LT CRL US-75
 N 403787.17, E 2557276.90, EL. 682.821

P:\FDB\650-TUL\CIV\400315_0001_EC2123A-US75\Design-Work\King\CIV\MicroStation\3378811-WPS\Sheets\3378811-PnP_Ramp_E2_02.dgn
 3/4/2021

R/W UTILITY MEETING

MARCH 2021

3/4/2021

P:\FDB\1650-TUL\CIV\1400315_0001_EC2123A_US75\Design-Working\CIV\MicroStation\3378811-WPS\Sheets\3378811-Profile-Ramp E3_0.dgn

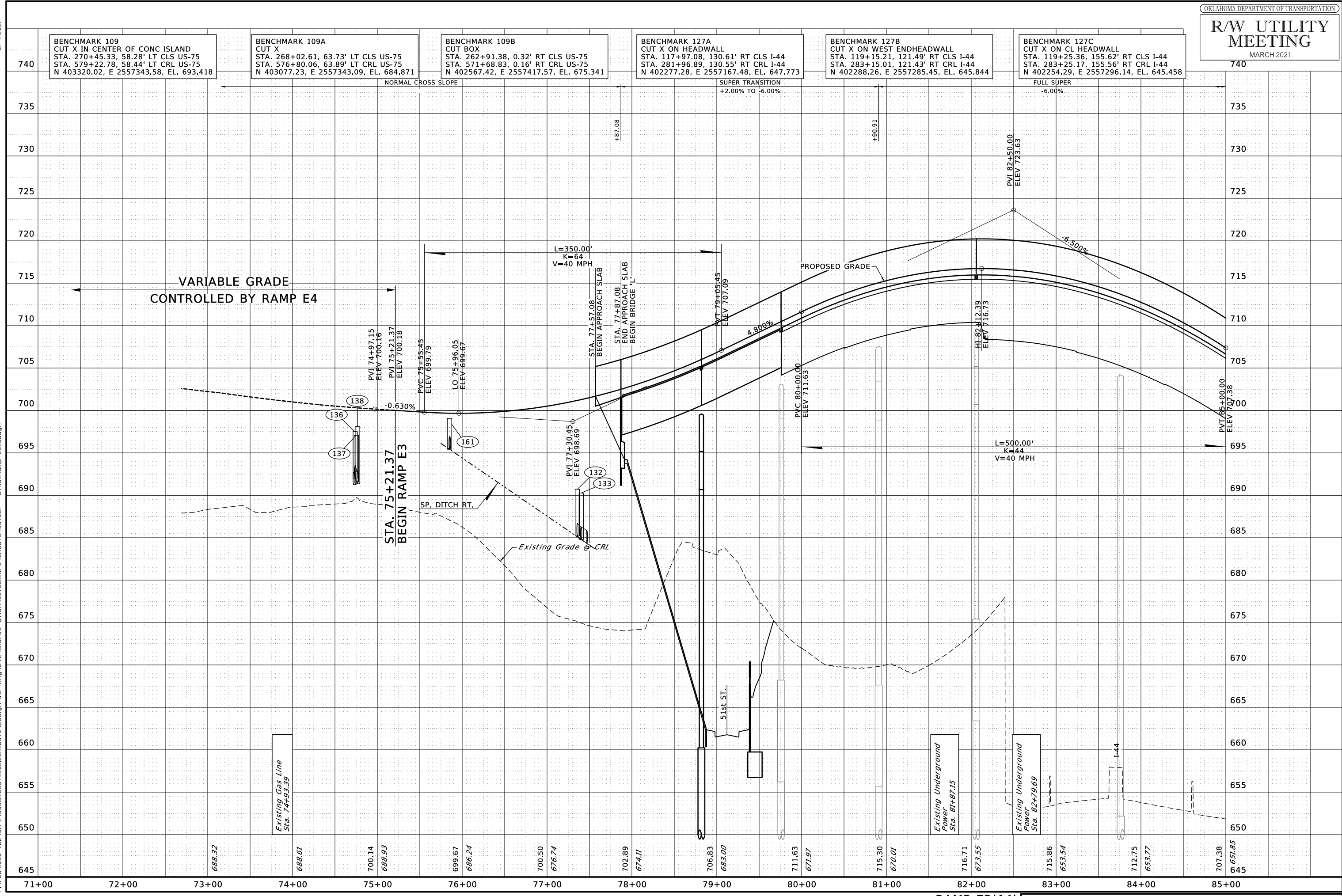

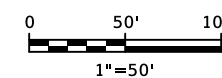

SEC. 35, T19N, R12E

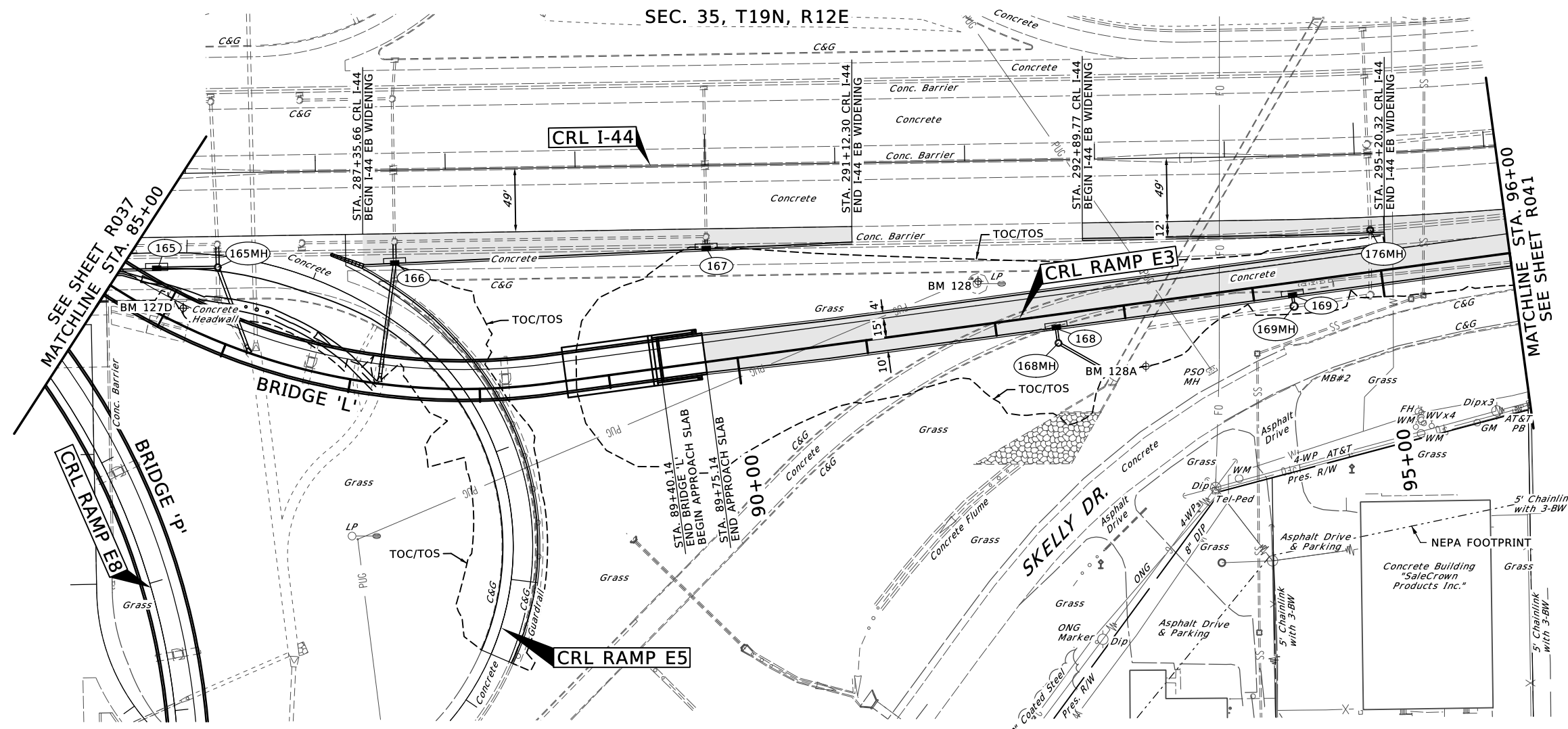

SEE SHEET R037
MATCHLINE STA. 85+00

MATCHLINE STA. 96+00
SEE SHEET R041

BENCHMARK 127D
CUT X ON HEADWALL
STA. 121+96.90, 103.87' RT CLS I-44
STA. 285+96.71, 103.79' RT CRL I-44
N 402310.30, E 2557566.83, EL. 649.568

BENCHMARK 128
CUT X ON BASE OF LP
STA. 128+09.05, 92.87' RT CLS I-44
STA. 292+08.86, 92.76' RT CRL I-44
N 402330.92, E 2558178.73, EL. 657.904

BENCHMARK 128A
CUT X
STA. 129+37.23, 160.28' RT CLS I-44
STA. 293+37.04, 160.17' RT CRL I-44
N 402265.52, E 2558307.95, EL. 650.276

- LEGEND**
- PROPOSED LIGHT POLE
 - ROADWAY
 - HISTORICAL DISTRICT

3/4/2021

P:\FDB\650-TUL\CIV\400315_0001-EC223A-UST5\Design-Working\CIV\MicroStation\337881-Plan-Ramp E3.dgn

3/4/2021

P:\FDB\650-TUL\CIV\400315_0001_EC2123A_US75\Design-Working\CIV\MicroStation\3378811-Profiles-Ramp E3-02.dgn

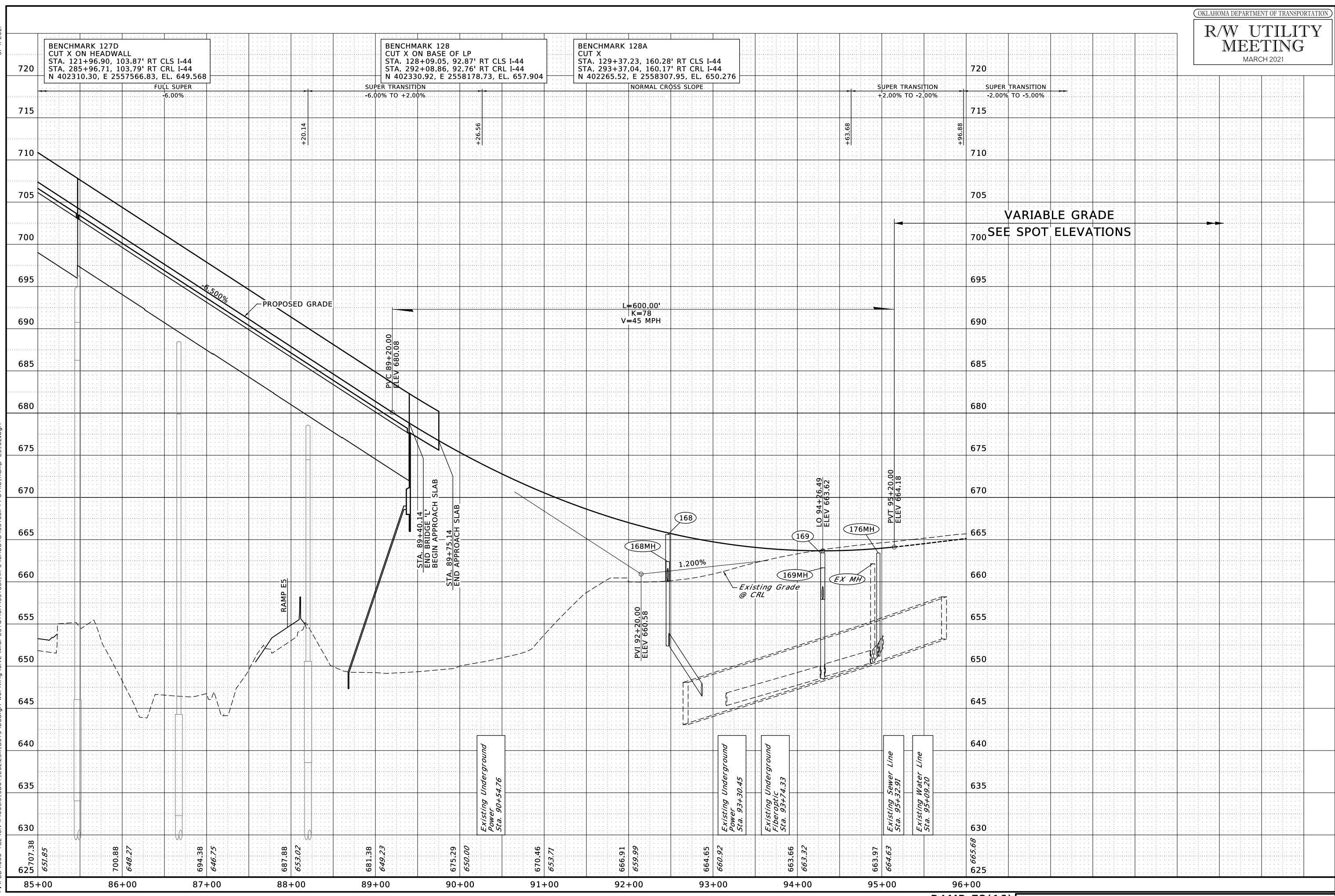

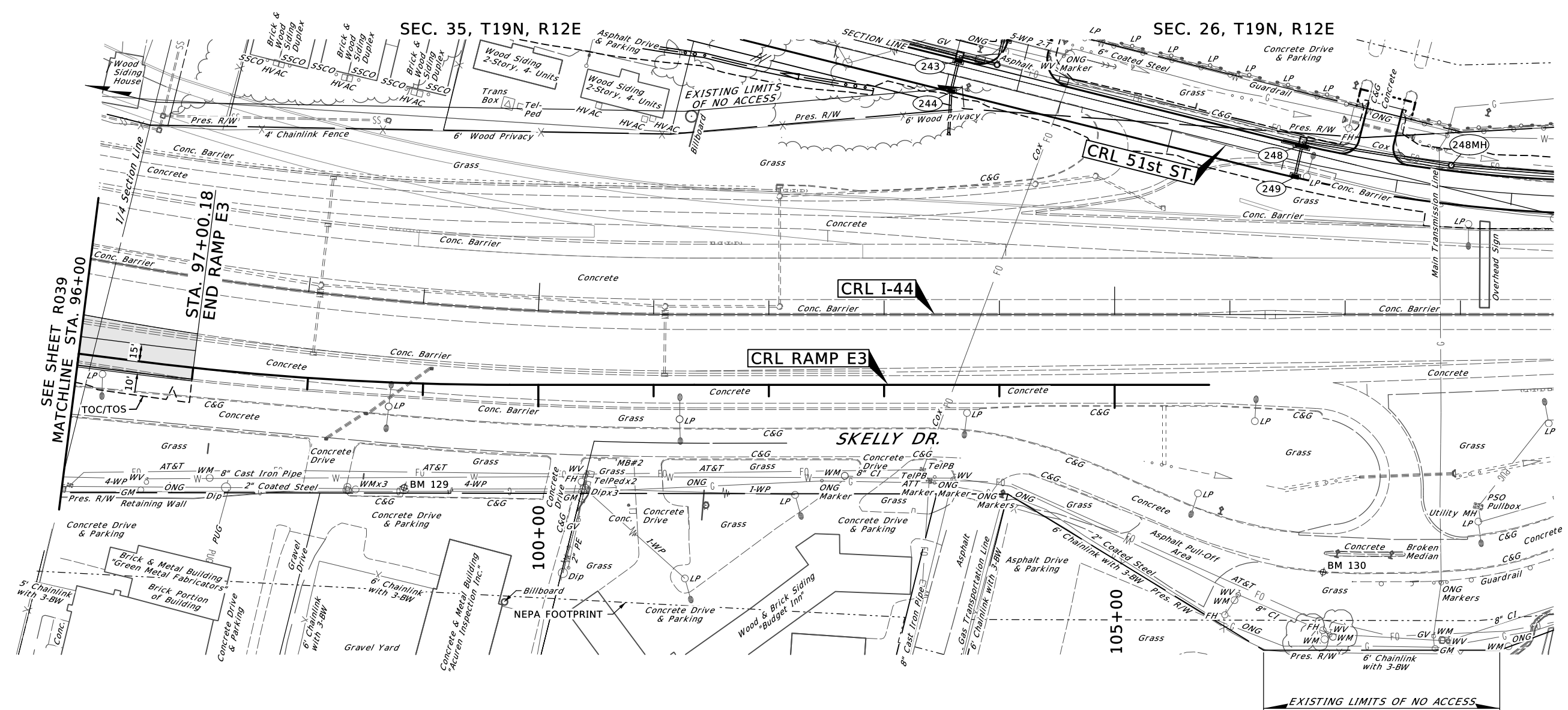
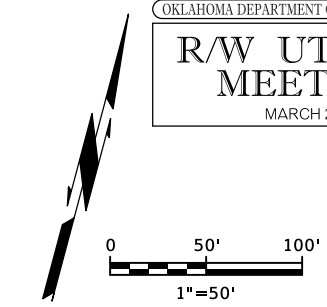

SEE SHEET R039
MATCHLINE STA. 96+00

STA. 97+00.18
END RAMP E3

BENCHMARK 129
RRSPIKE N FACE OF PP
STA. 134+96.86, 161.00' RT CLS I-44
STA. 298+96.69, 160.86' RT CRL I-44
N 402313.10, E 2558890.73, EL. 661.926

BENCHMARK 130
CUT X ON TC
STA. 142+81.01, 223.73' RT CLS I-44
STA. 306+80.86, 223.55' RT CRL I-44
N 402447.59, E 2559680.06, EL. 669.283

- LEGEND**
- PROPOSED LIGHT POLE
 - ROADWAY
 - HISTORICAL DISTRICT

3/4/2021

P:\FDB\650-TUL\CIV\400315_0001_EC223A_US75\Design-Work\King\CIV\MicroStation\337881\WPS\Sheets\337881-Plan-Ramp E3.dgn

R/W UTILITY MEETING

MARCH 2021

3/4/2021

BENCHMARK 129
 RRSPIKE N FACE OF PP
 STA. 134+96.86, 161.00' RT CLS I-44
 STA. 298+96.69, 160.86' RT CRL I-44
 N 402313.10, E 2558890.73, EL. 661.926

BENCHMARK 130
 CUT X ON TC
 STA. 142+81.01, 223.73' RT CLS I-44
 STA. 306+80.86, 223.55' RT CRL I-44
 N 402447.59, E 2559680.06, EL. 669.283

SUPER TRANSITION
 -2.00% TO -5.00%

FULL SUPER
 -5.00%

+96.78

VARIABLE GRADE
 SEE SPOT ELEVATIONS

PVI 97+00.18
 ELEV 666.45

STA. 97+00.18
 END RAMP E3

Existing Grade @ CRL

Existing Underground
 Fiberoptic
 Sta. 103+61.18

665.68

666.45

667.20

667.93

668.64

669.11

669.41

669.73

670.05

670.14

96+00 97+00 98+00 99+00 100+00 101+00 102+00 103+00 104+00 105+00 106+00 107+00 108+00 109+00 110+00

720

715

710

705

700

695

690

685

680

675

670

665

660

655

650

645

640

635

630

625

P:\FDB\1650-TUL\CIV\1400315_0001_EC2123A_US75\Design-Working\CIV\MicroStation\33788\1\WPS\Sheets\33788\1-Profile_Ramp_E3_03.dgn

R/W UTILITY MEETING

MARCH 2021

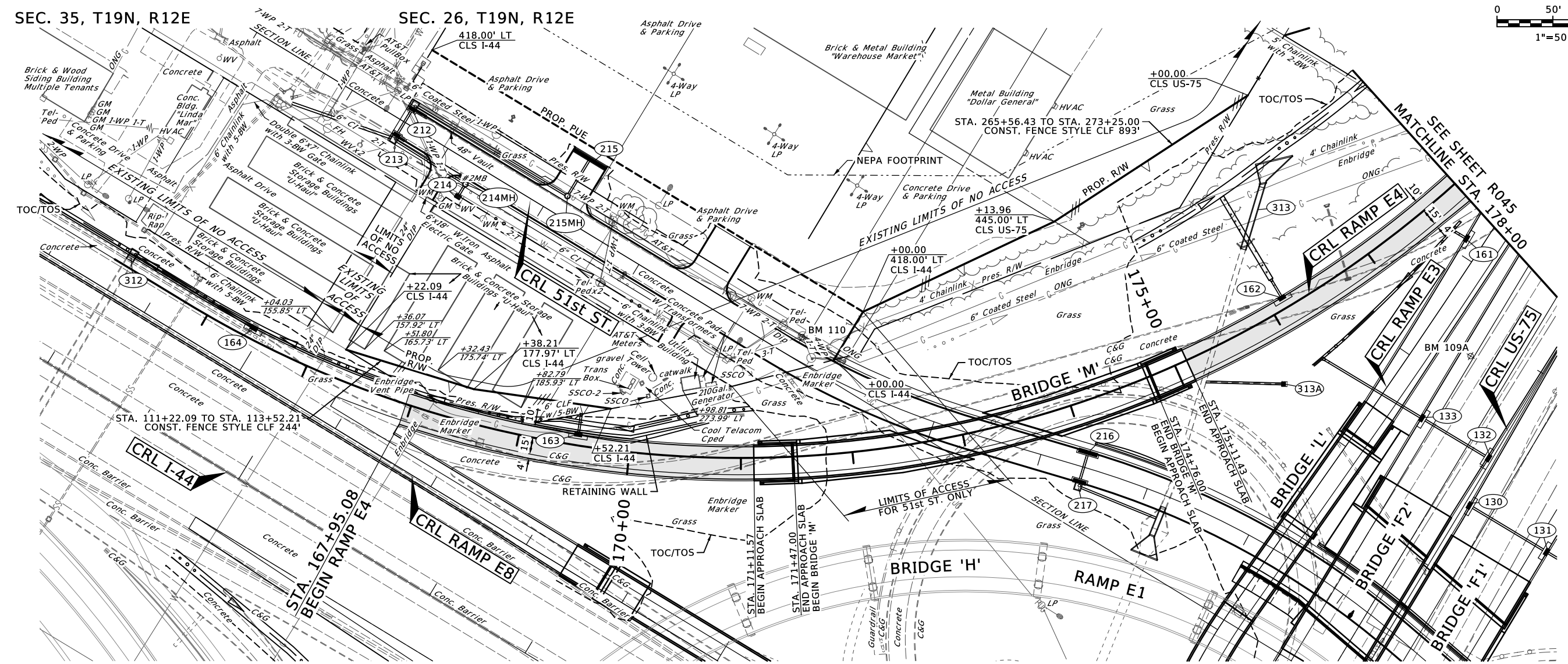
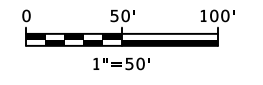
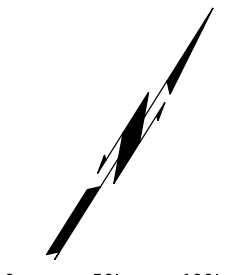

SEC. 35, T19N, R12E

SEC. 26, T19N, R12E

BENCHMARK 110
RR SPIKE S/E PP
STA. 265+09.14, 585.09' LT CLS US-75
STA. 573+86.59, 585.25' LT CRL US-75
N 402773.16, E 2556827.84, EL. 673.94

BENCHMARK 109A
CUT X
STA. 268+02.61, 63.73' LT CLS US-75
STA. 576+80.06, 63.89' LT CRL US-75
N 403077.23, E 2557343.09, EL. 684.871

- LEGEND**
- PROPOSED LIGHT POLE
 - ROADWAY
 - HISTORICAL DISTRICT

3/4/2021

P:\FDB\650-TUL\CIV\400315_0001-EC2123A-UST5\Design-Work\King\CIV\MicroStation\337881\WPS\Sheets\337881-Plan-Ramp E4.dgn

3/4/2021

BENCHMARK 110
RR SPIKE S/E PP
STA. 265+09.14, 585.09' LT CLS US-75
STA. 573+86.59, 585.25' LT CRL US-75
N 402773.16, E 2556827.84, EL. 673.94

BENCHMARK 109A
CUT X
STA. 268+02.61, 63.73' LT CLS US-75
STA. 576+80.06, 63.89' LT CRL US-75
N 403077.23, E 2557343.09, EL. 684.871

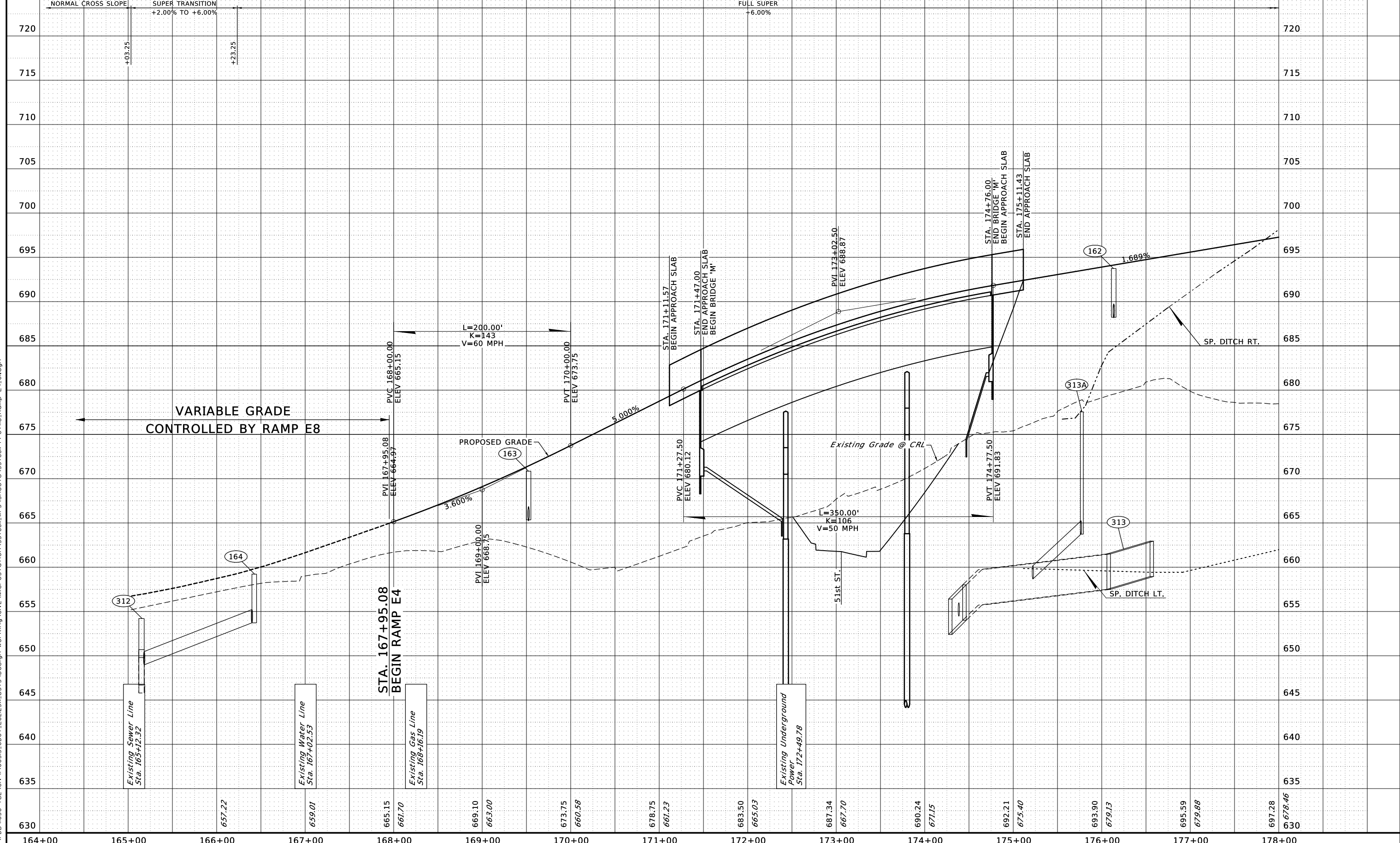

P:\FDB\1650-TUL\CIV\1400315_0001_EC213A_US75\Design-Work\King\CIV\MicroStation\337881\WPS\Sheets\337881-Profile-Ramp E4_0.dgn

164+00 165+00 166+00 167+00 168+00 169+00 170+00 171+00 172+00 173+00 174+00 175+00 176+00 177+00 178+00

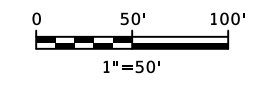

SEC. 26, T19N, R12E

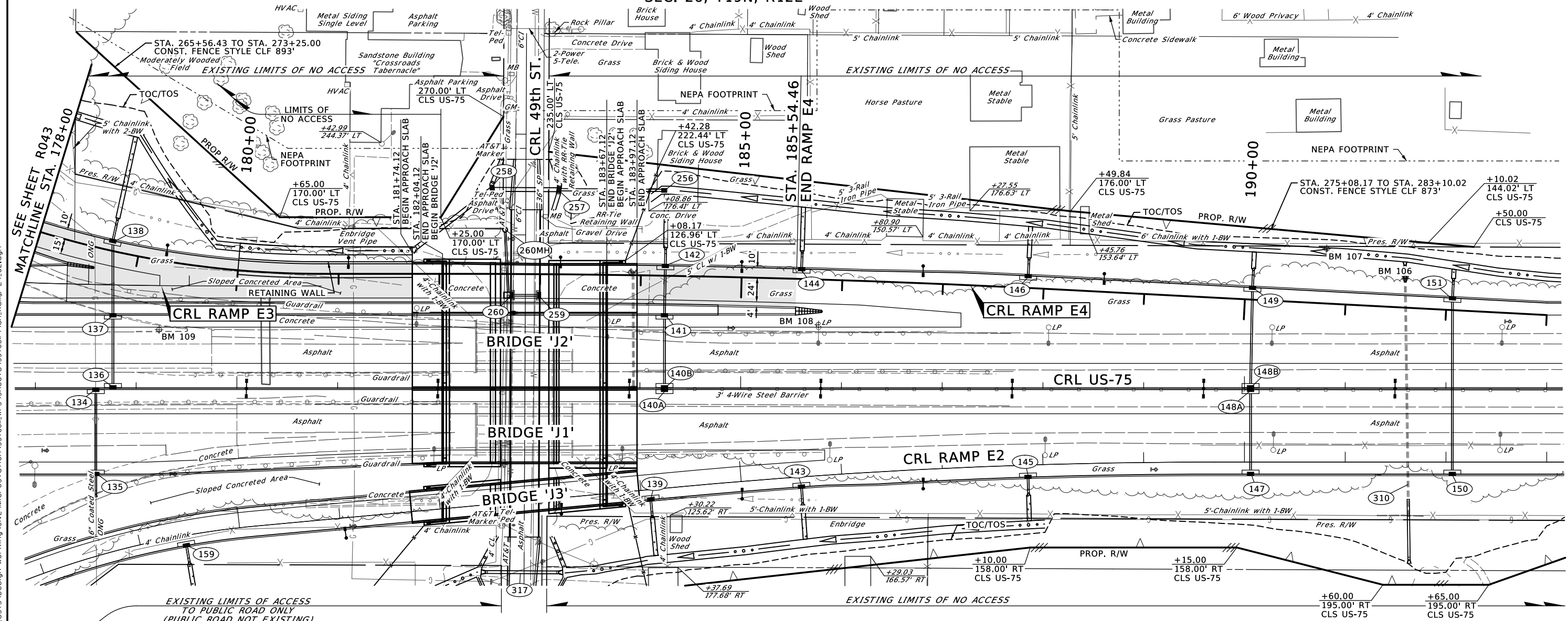

LEGEND

- PROPOSED LIGHT POLE
- ROADWAY
- HISTORICAL DISTRICT

BENCHMARK 109
CUT X IN CENTER OF CONC ISLAND
STA. 270+45.33, 58.28' LT CLS US-75
STA. 579+22.78, 58.44' LT CRL US-75
N 403320.02, E 2557343.58, EL. 693.418

BENCHMARK 108
3/8" IPC
STA. 276+99.78, 63.16' LT CLS US-75
STA. 585+77.23, 63.32' LT CRL US-75
N 403974.23, E 2557325.32, EL. 706.998

BENCHMARK 107
5/8" IPC ALUM CAP
STA. 282+04.18, 138.73' LT CLS US-75
STA. 590+81.63, 138.89' LT CRL US-75
N 404476.97, E 2557239.46, EL. 701.479

BENCHMARK 106
CUT X
STA. 282+82.18, 109.02' LT CLS US-75
STA. 591+59.63, 109.18' LT CRL US-75
N 404555.57, E 2557267.57, EL. 701.263

3/4/2021
P:\FDB\1650-TUL\CIV\1400315_0001-EC2123A-US75\Design-Working\CIV\MicroStation\33788(11)\Sheets\WPS\33788(11)\Plan_Ramp_E4_02.dgn

R/W UTILITY MEETING

MARCH 2021

3/4/2021

BENCHMARK 109
 CUT X IN CENTER OF CONC ISLAND
 STA. 270+45.33, 58.28' LT CLS US-75
 STA. 579+22.78, 58.44' LT CRL US-75
 N 403320.02, E 2557343.58, EL. 693.418

BENCHMARK 108
 3/8"IPC
 STA. 276+99.78, 63.16' LT CLS US-75
 STA. 585+77.23, 63.32' LT CRL US-75
 N 403974.23, E 2557325.32, EL. 706.998

BENCHMARK 107
 5/8"IP ALUM CAP
 STA. 282+04.18, 138.73' LT CLS US-75
 STA. 590+81.63, 138.89' LT CRL US-75
 N 404476.97, E 2557239.46, EL. 701.479

BENCHMARK 106
 CUT X
 STA. 282+82.18, 109.02' LT CLS US-75
 STA. 591+59.63, 109.18' LT CRL US-75
 N 404555.57, E 2557267.57, EL. 701.263

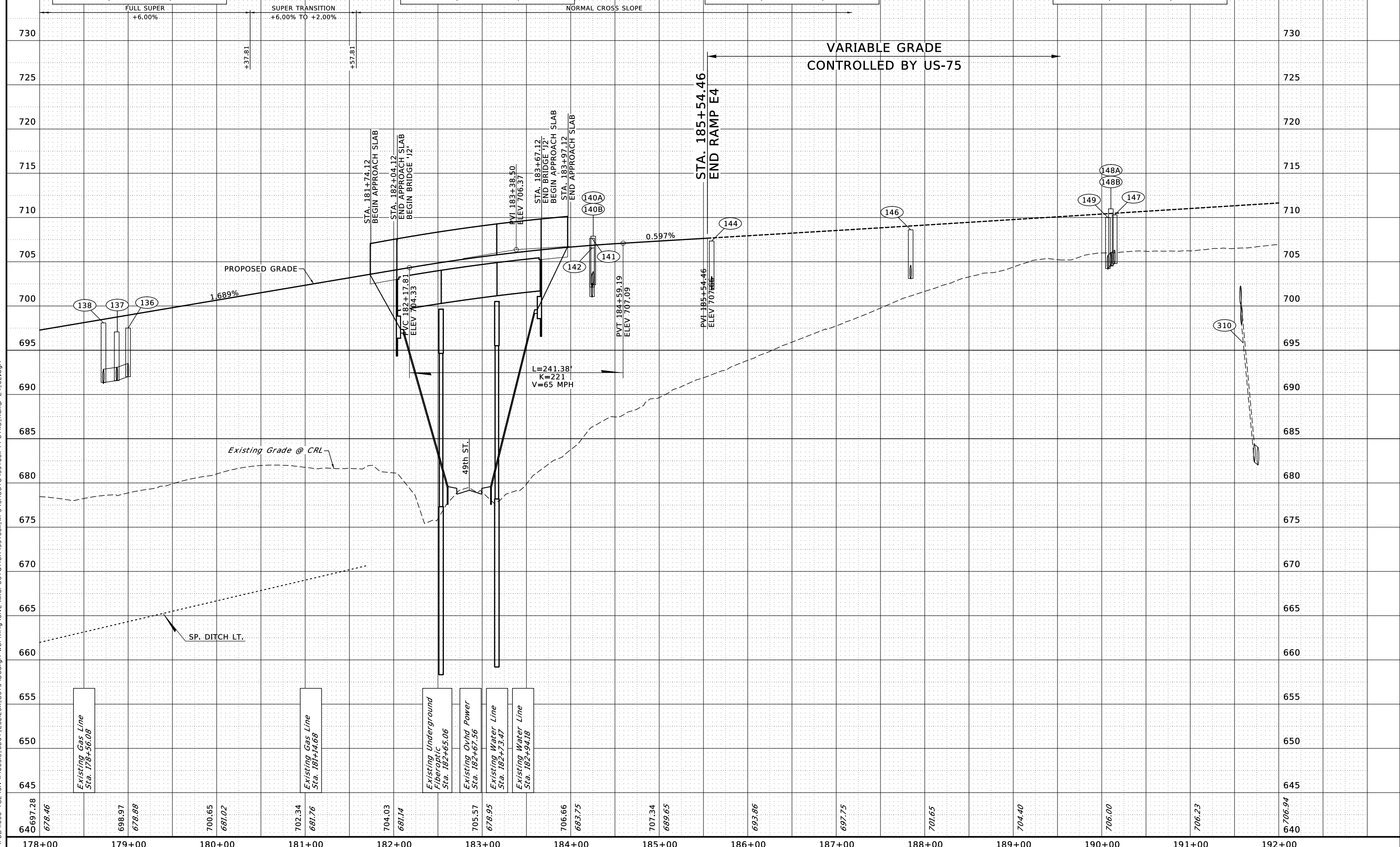

P:\FDB\650-TUL\CIV\400315_0001_EC2123A_US75\Design-Work\King\CIV\MicroStation\3378811\WPS\Sheets\3378811-Profile-Ramp E4_02.dgn

3/4/2021

P:\FDB\1650-TUL\CIV\1400315_0001_EC2123A-US75\Design-Work\King\CIV\MicroStation\3378811\WPS\Sheets\3378811-PnP_Ramp_E5_0.dgn

OKLAHOMA DEPARTMENT OF TRANSPORTATION

R/W UTILITY MEETING

MARCH 2021

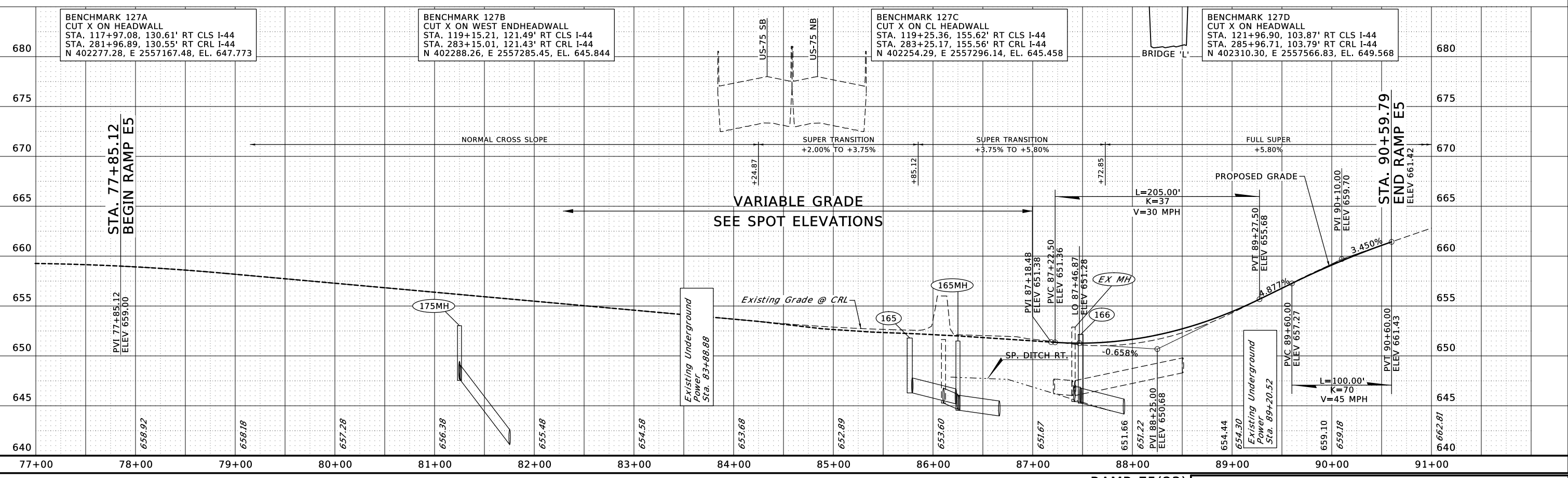
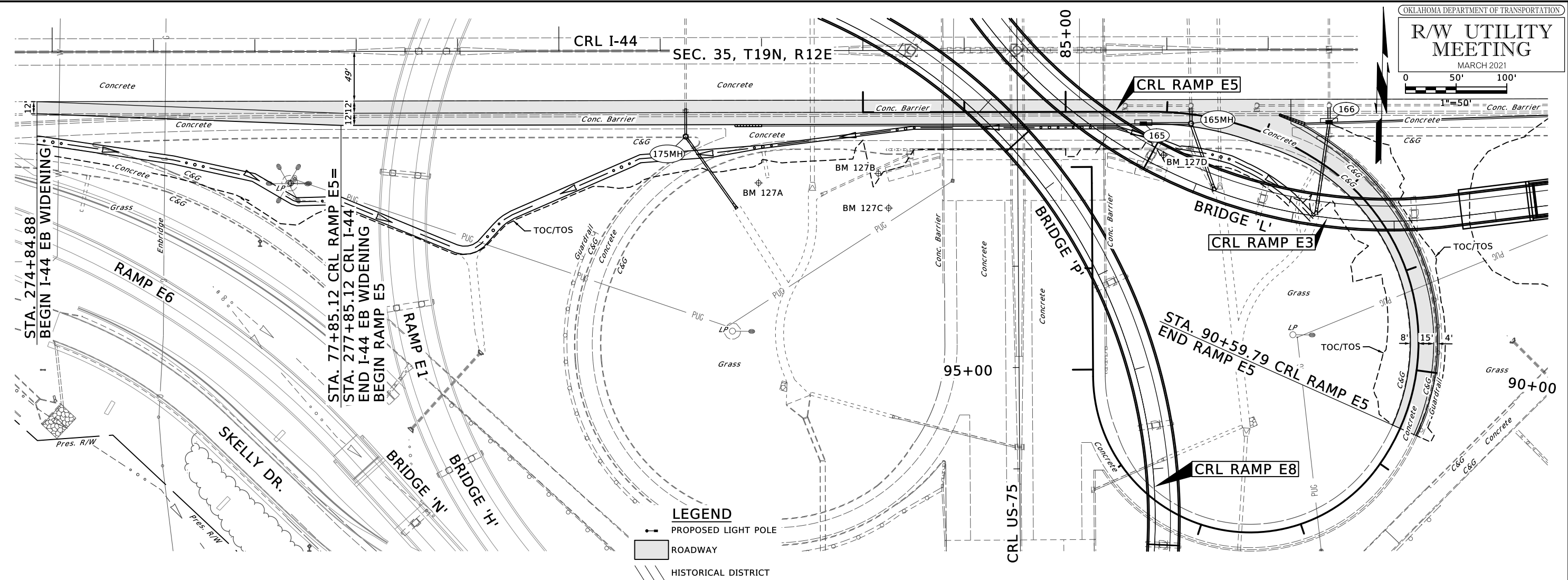

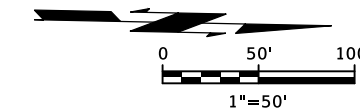

SEC. 35, T19N, R12E

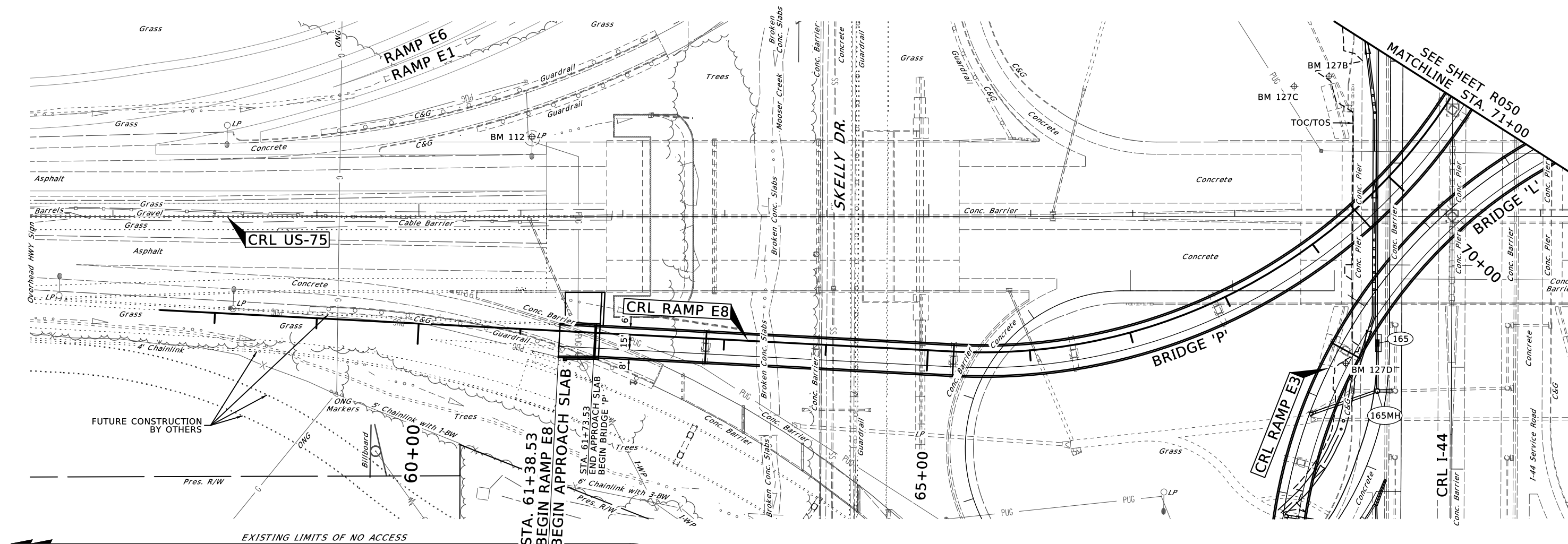

- LEGEND**
- PROPOSED LIGHT POLE
 - ROADWAY
 - HISTORICAL DISTRICT

BENCHMARK 112
 BOX FOUND
 STA. 252+33.25, 78.24' LT CLS US-75
 STA. 561+10.70, 78.40' LT CRL US-75
 N 401507.90, E 2557360.66, EL. 674.919

BENCHMARK 127B
 CUT X ON WEST END HEADWALL
 STA. 119+15.21, 121.49' RT CLS I-44
 STA. 283+15.01, 121.43' RT CRL I-44
 N 402288.26, E 2557285.45, EL. 645.844

BENCHMARK 127C
 CUT X ON CL HEADWALL
 STA. 119+25.36, 155.62' RT CLS I-44
 STA. 283+25.17, 155.56' RT CRL I-44
 N 402254.29, E 2557296.14, EL. 645.458

BENCHMARK 127D
 CUT X ON HEADWALL
 STA. 121+96.90, 103.87' RT CLS I-44
 STA. 285+96.71, 103.79' RT CRL I-44
 N 402310.30, E 2557566.83, EL. 649.568

P:\FDB\1650-TUL\CIV\1400315_0001-EC213A-UST5\Design-Work\King\CIV\MicroStation\337881-WPS\Sheets\337881-Plan-Ramp EB_OI.dgn 3/4/2021

R/W UTILITY MEETING

MARCH 2021

3/4/2021

P:\FDB\650-TUL\CIV\400315_0001_EC2123A_US75\Design-Working\CIV\MicroStation\33788\1-Profile-Ramp E8_01.dgn

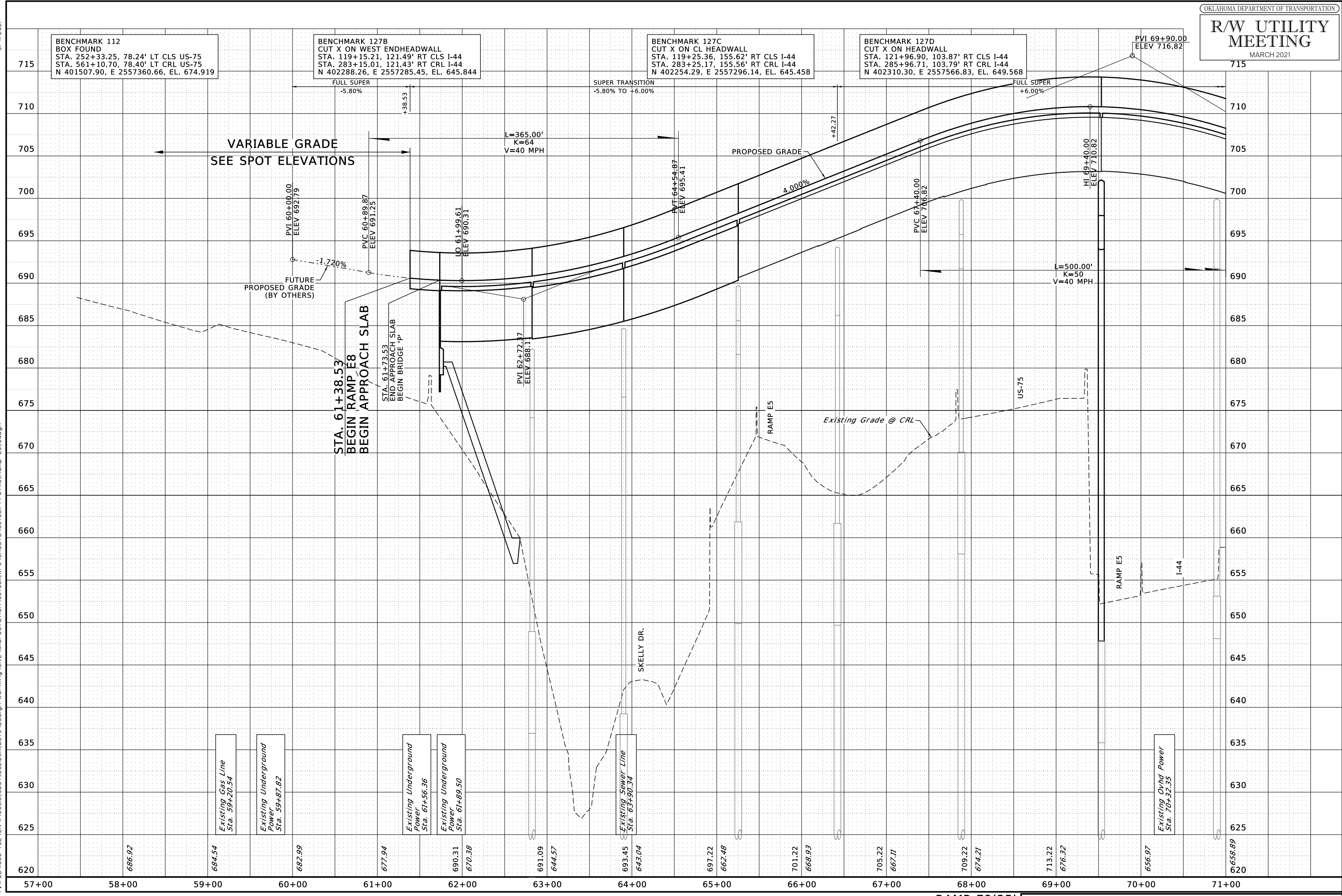

BENCHMARK 112
 BOX FOUND
 STA. 252+33.25, 78.24' LT CLS US-75
 STA. 561+10.70, 78.40' LT CRL US-75
 N 401507.90, E 2557360.66, EL. 674.919

BENCHMARK 127B
 CUT X ON WEST END HEADWALL
 STA. 119+15.21, 121.49' RT CLS I-44
 STA. 283+15.01, 121.43' RT CRL I-44
 N 402288.26, E 2557285.45, EL. 645.844

BENCHMARK 127C
 CUT X ON CL HEADWALL
 STA. 119+25.36, 155.62' RT CLS I-44
 STA. 283+25.17, 155.56' RT CRL I-44
 N 402254.29, E 2557296.14, EL. 645.458

BENCHMARK 127D
 CUT X ON HEADWALL
 STA. 121+96.90, 103.87' RT CLS I-44
 STA. 285+96.71, 103.79' RT CRL I-44
 N 402310.30, E 2557566.83, EL. 649.568

PVI 69+90.00
 ELEV 716.82

VARIABLE GRADE
 SEE SPOT ELEVATIONS

PROPOSED GRADE

FUTURE PROPOSED GRADE (BY OTHERS)

STA. 61+38.53
 BEGIN RAMP E8
 BEGIN APPROACH SLAB

STA. 61+73.53
 END APPROACH SLAB
 BEGIN BRIDGE 'P'

Existing Grade @ CRL

US-75

RAMP E5

I-44

R/W UTILITY MEETING

MARCH 2021

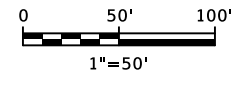

3/4/2021

P:\FDB\650-TUL\CIV\400315_0001-EC2123A-UST5\Design-Working\CIV\MicroStation\3378811\WPS\Sheets\3378811-Plan-Ramp EB_02.dgn

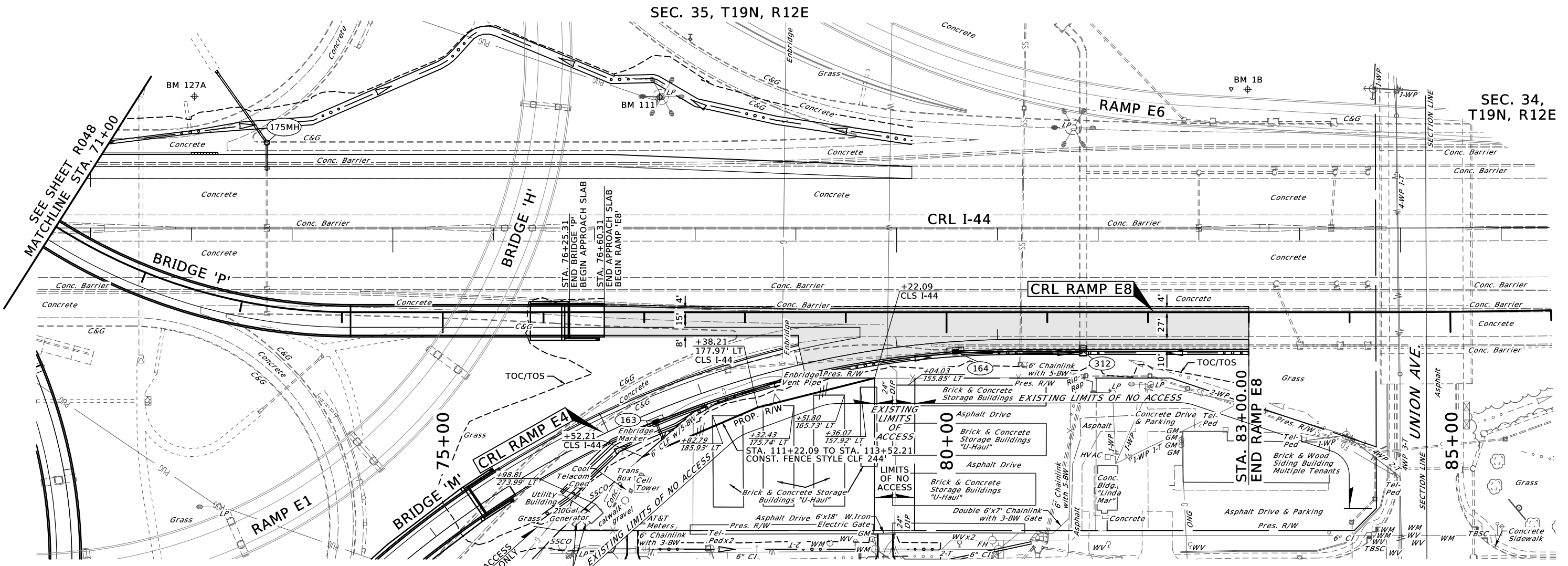

BENCHMARK 127A
CUT X ON HEADWALL
STA. 117+97.08, 130.61' RT CLS I-44
STA. 281+96.89, 130.55' RT CRL I-44
N 402277.28, E 2557167.48, EL. 647.773

BENCHMARK 111
BOX FOUND
STA. 260+09.27, 717.04' LT CLS US-75
STA. 568+86.72, 717.20' LT CRL US-75
N 402270.70, E 2556706.13, EL. 652.581

BENCHMARK 1B
3/8IP
STA. 107+68.14, 137.98' RT CLS I-44
STA. 271+67.95, 137.97' RT CRL I-44
N 402253.76, E 2556138.79, EL. 669.34

- LEGEND**
- PROPOSED LIGHT POLE
 - ROADWAY
 - HISTORICAL DISTRICT

3/4/2021
 P:\FDB\1650-TUL\CIV\1400315_0001_EC2123A_US75\Design-Work\King\CIV\MicroStation\3378811\WPS\Sheets\3378811-Profile-Ramp_E8_02.dgn

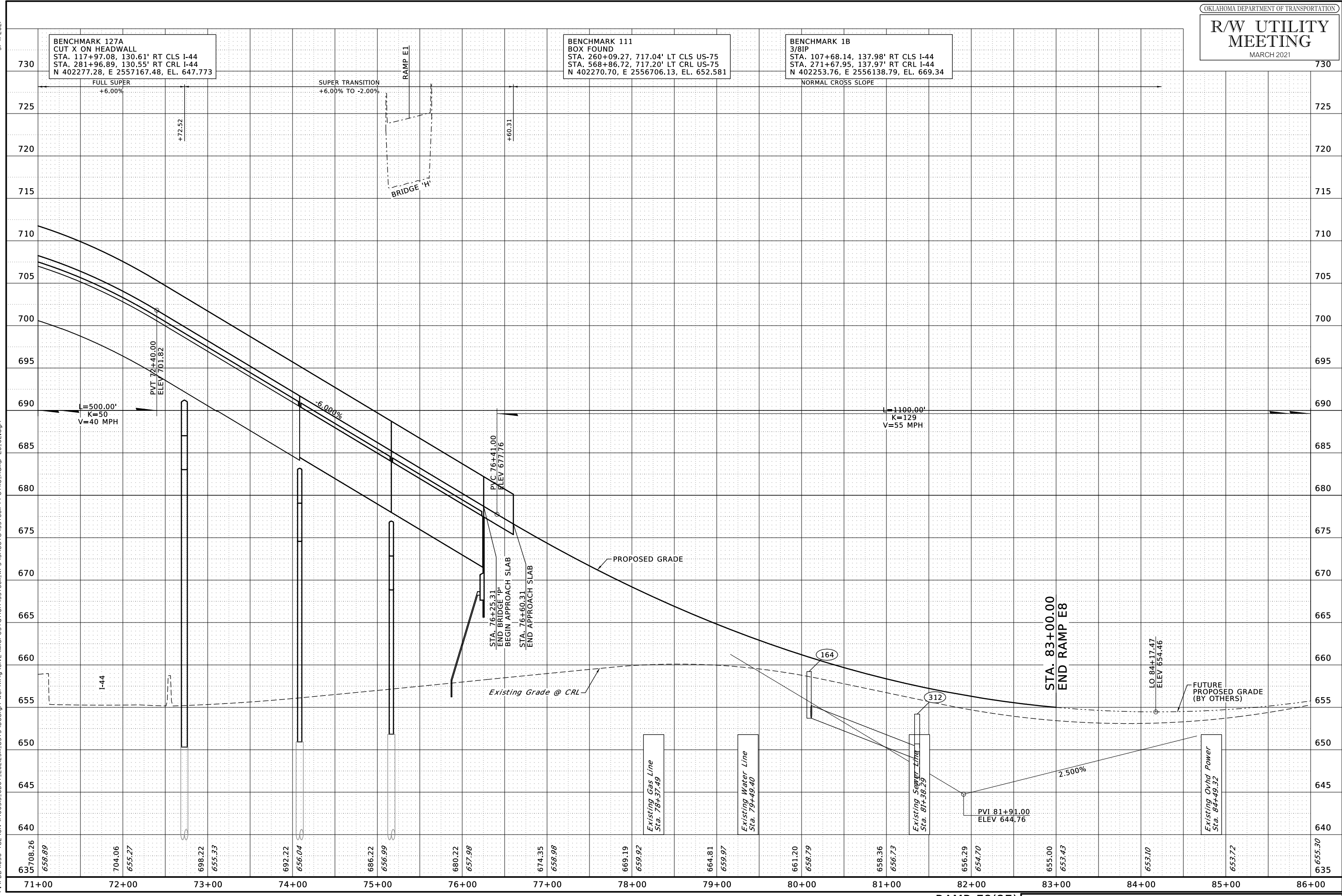

3/4/2021

P:\FDB\650-TUL\CIV\400315_0001_EC223A_US75\Design-Work\King\CIV\MicroStation\337881-WPS\Sheets\337881-Prop-Ramp Z_01.dgn

LEGEND

- PROPOSED LIGHT POLE
- ▭ ROADWAY
- ▨ HISTORICAL DISTRICT

SEC. 26, T19N, R12E

OKLAHOMA DEPARTMENT OF TRANSPORTATION

R/W UTILITY MEETING

MARCH 2021

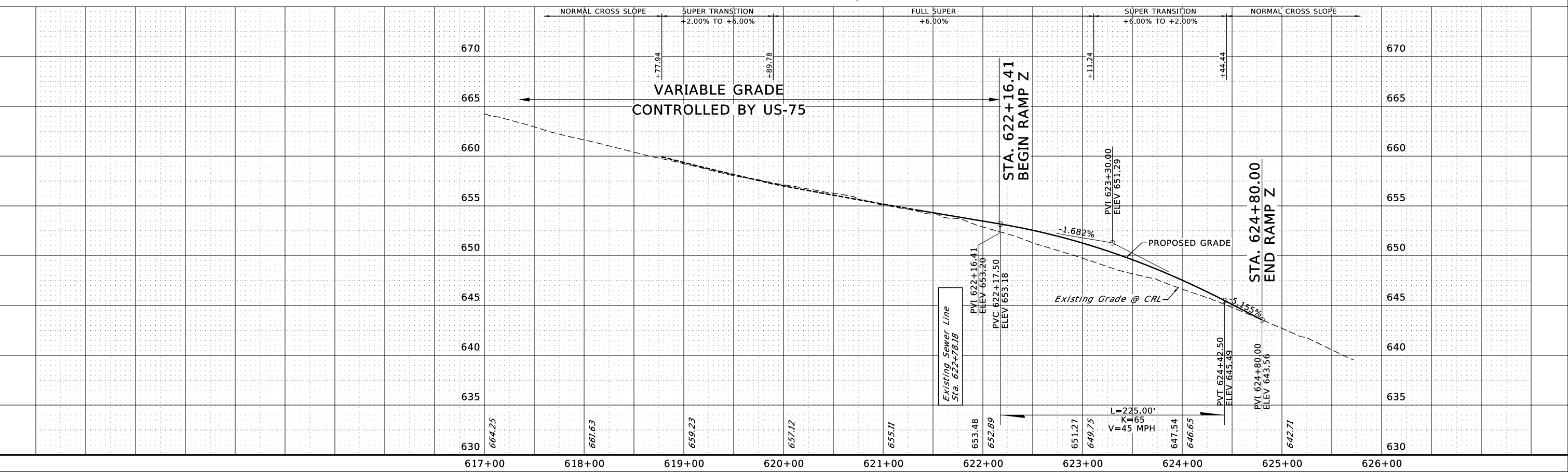
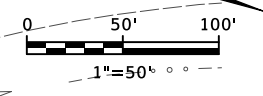
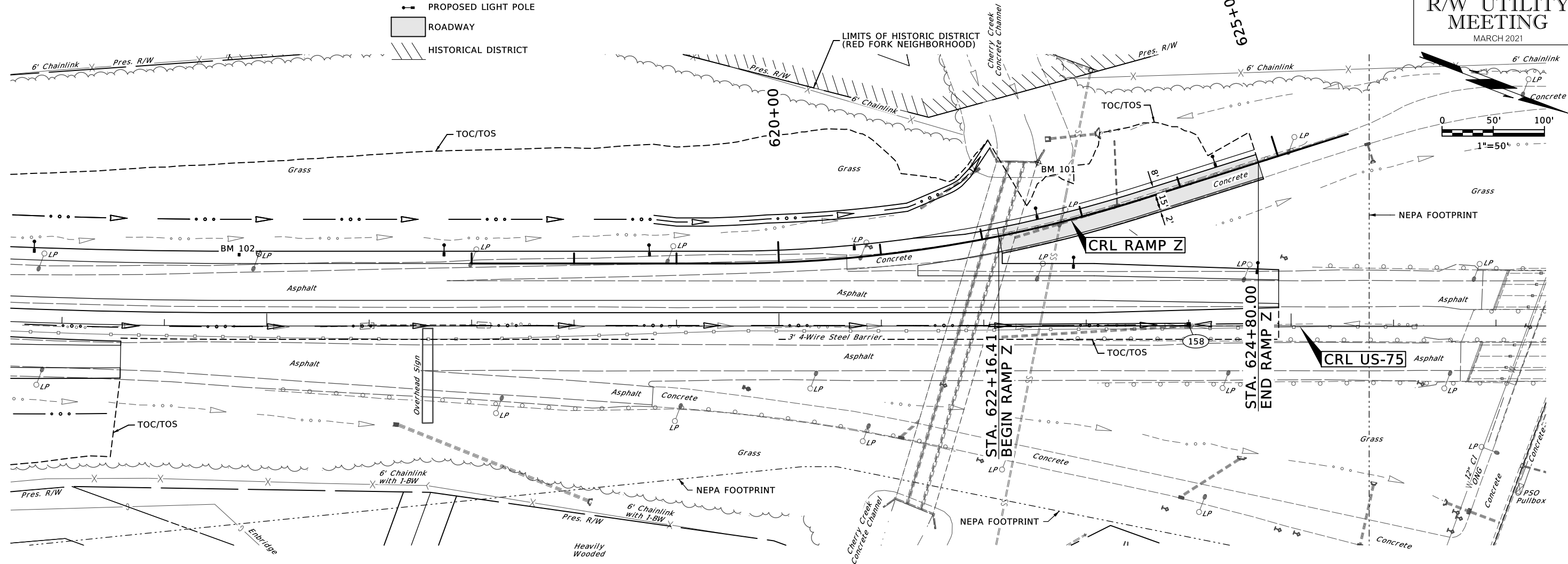

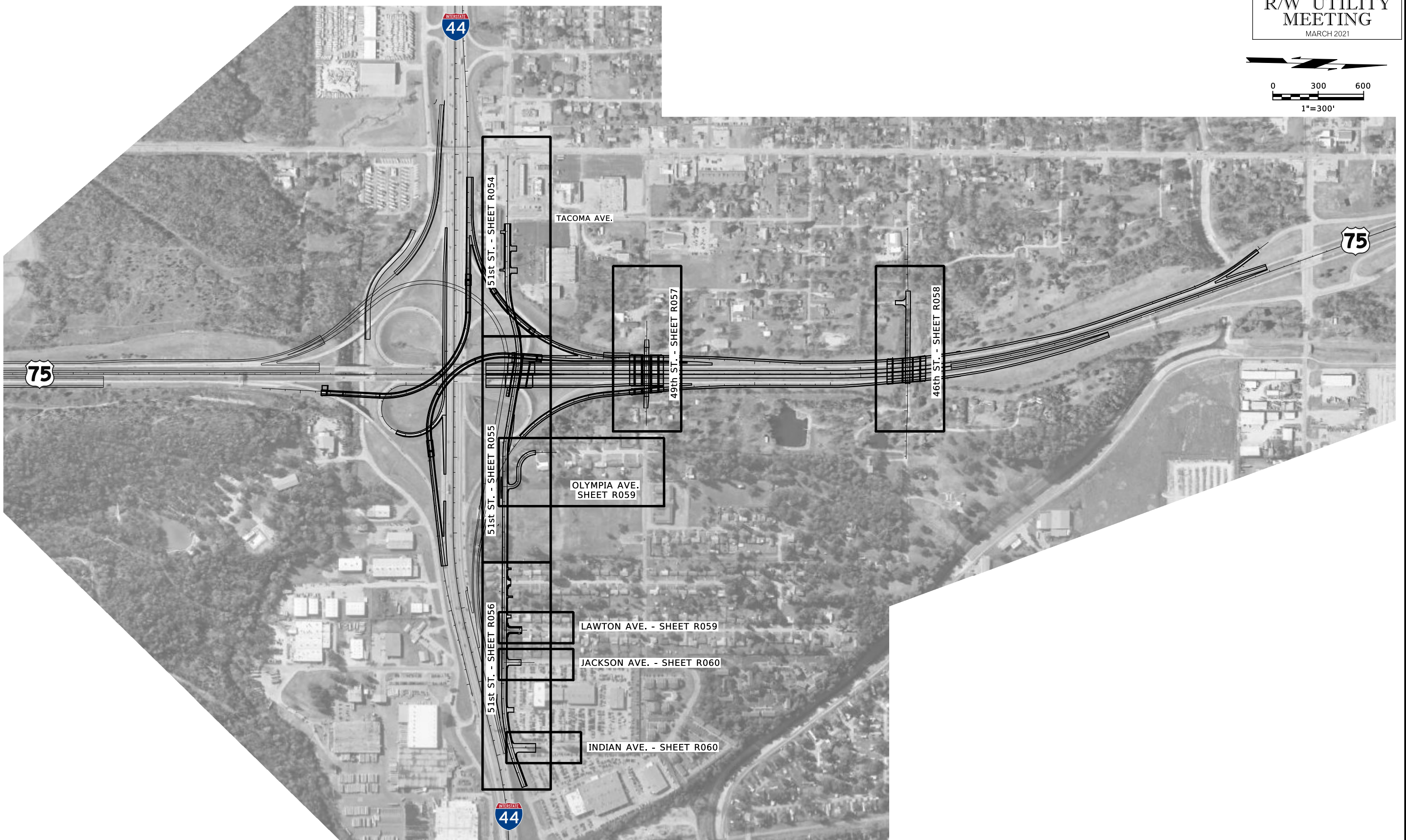
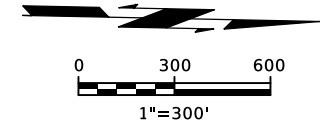

DESIGN	
DRAWN	
CHECKED	
APPROVED	
SQUAD	

OKLAHOMA DEPARTMENT OF TRANSPORTATION

**PLAN KEY MAP
(LOCAL ROADS)**

3/4/2021

P:\FDB\650-TUL\CIV\400315_0001_EC2123A_US75_Design-Work\King\CIV\MicroStation\337881-WPS\Sheets\337881-PnP_51st-01.dgn

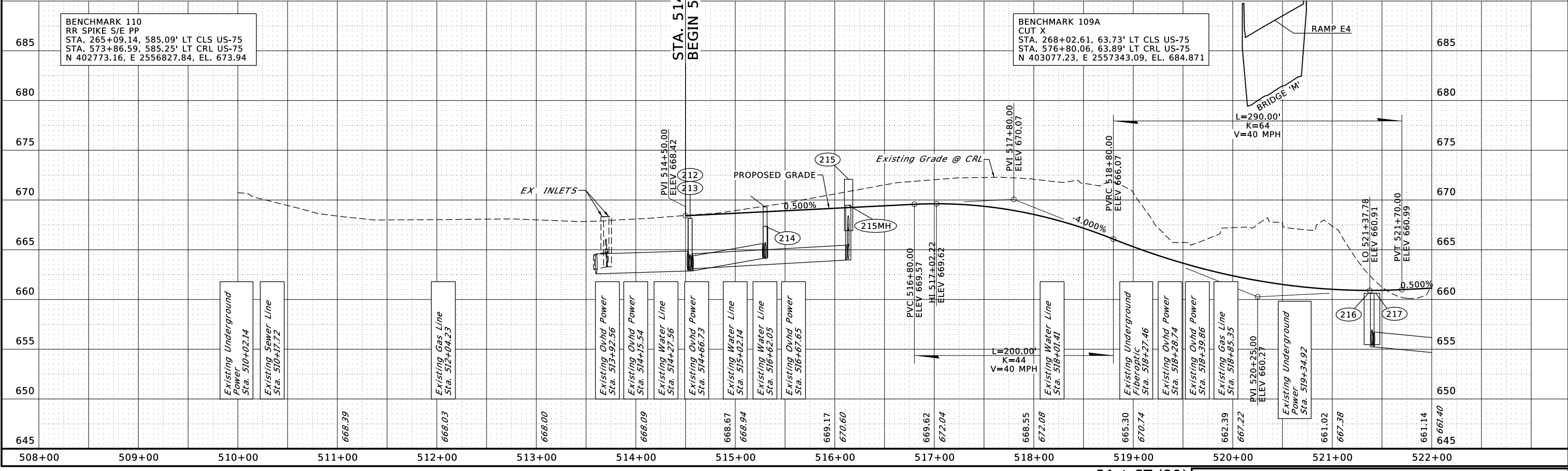
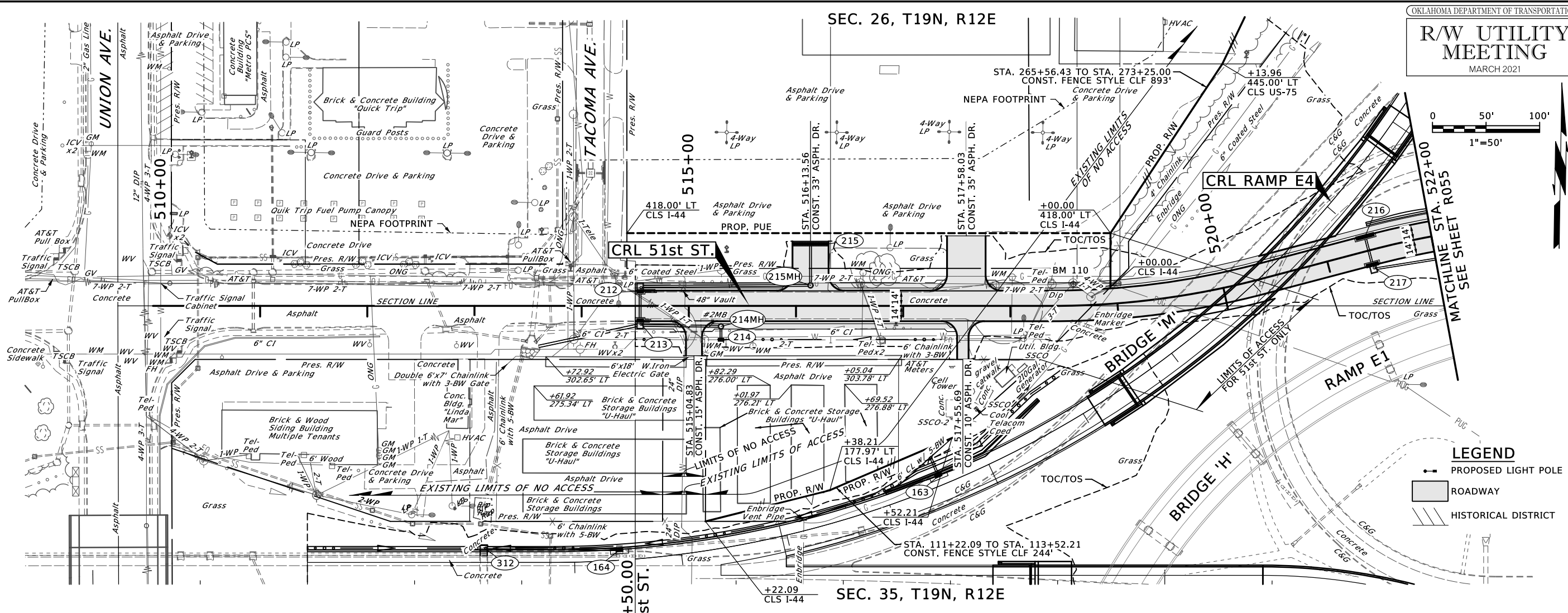
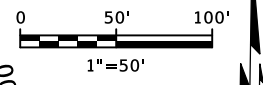

3/4/2021

P:\FDB\650-TUL\CIV\400315_0001_EC2123A_US75_Design-Work\King\CIV\MicroStation\337881-WPS\Sheets\337881-Prop_51st-02.dgn

LEGEND

- PROPOSED LIGHT POLE
- ROADWAY
- HISTORICAL DISTRICT

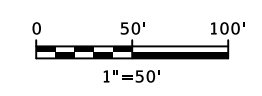

SEC. 26, T19N, R12E

SEC. 35, T19N, R12E

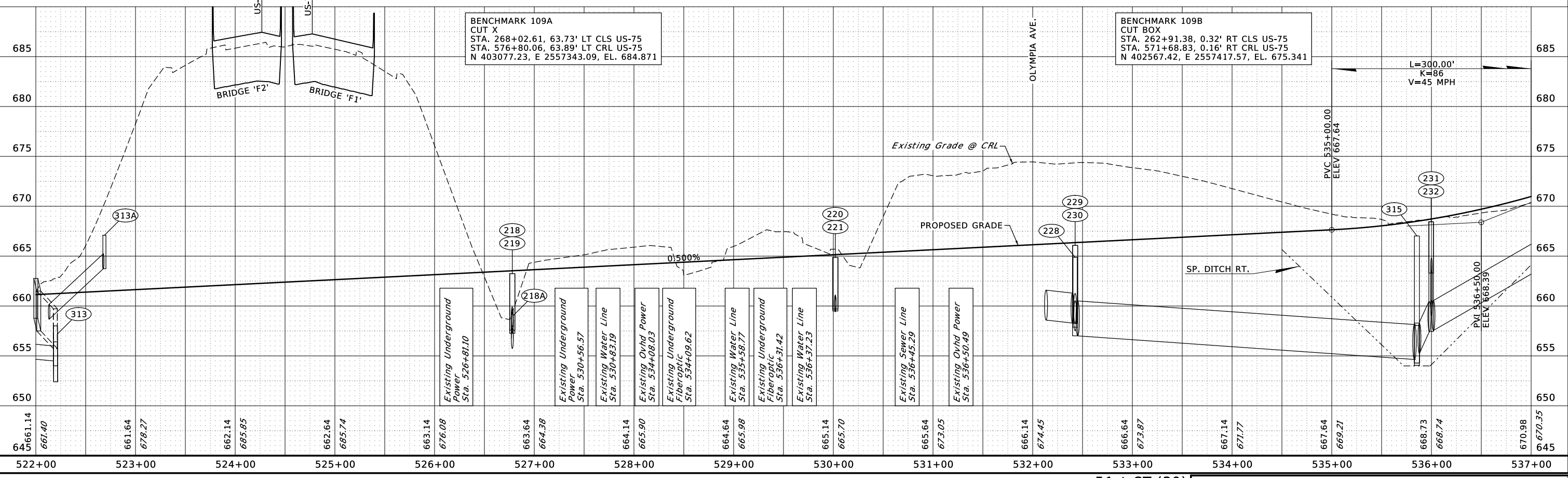
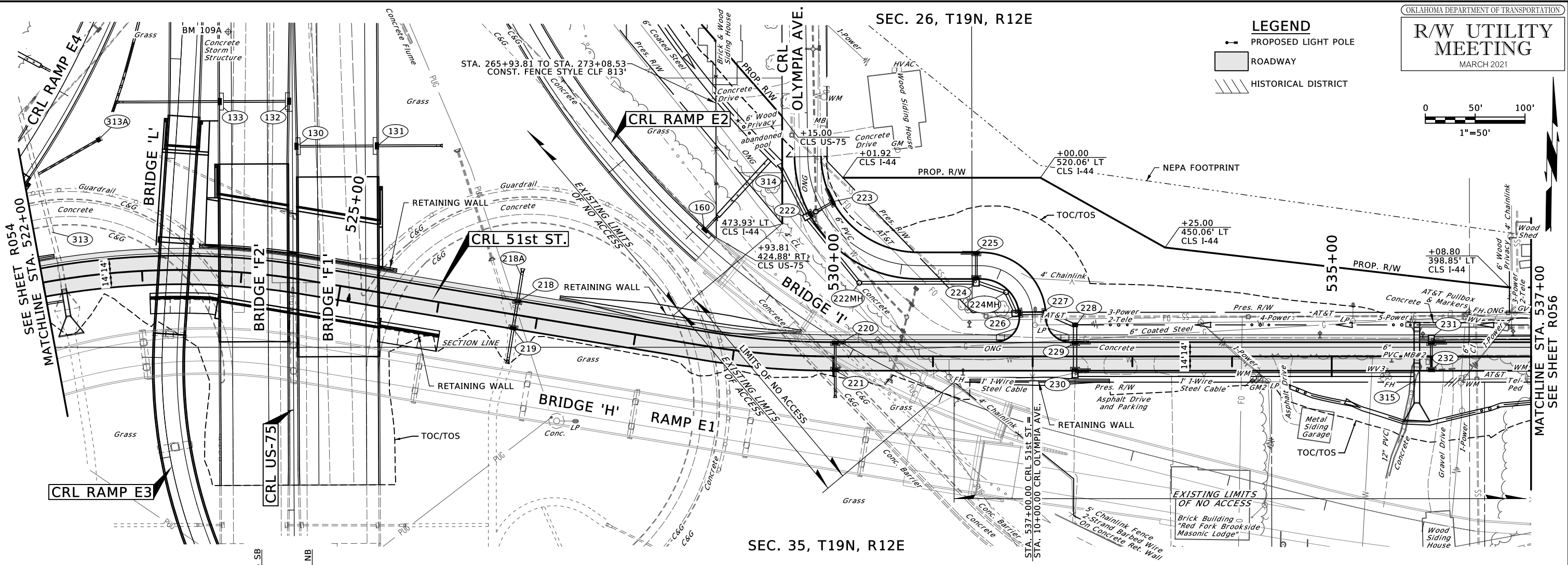

3/4/2021
 P:\FDB\650-TUL\CIV\400315_0001_EC2123A_US75_Design-Work\King_CIV\MicroStation\337881-WPS\Sheets\337881-Prop_S1st_03.dgn

LEGEND
 PROPOSED LIGHT POLE
 ROADWAY
 HISTORICAL DISTRICT

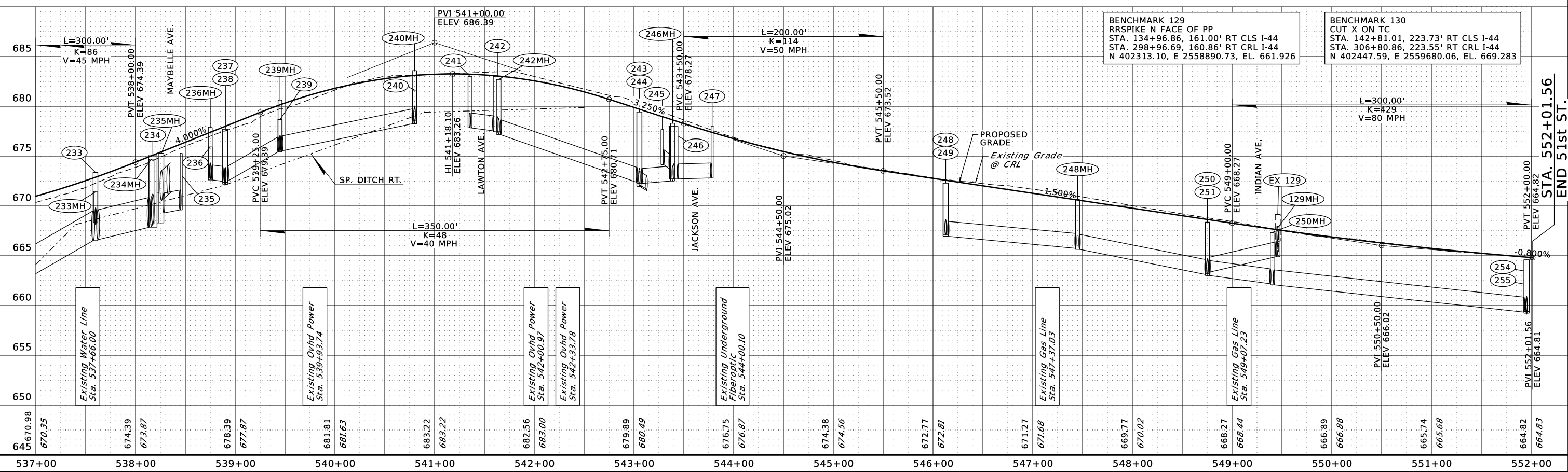
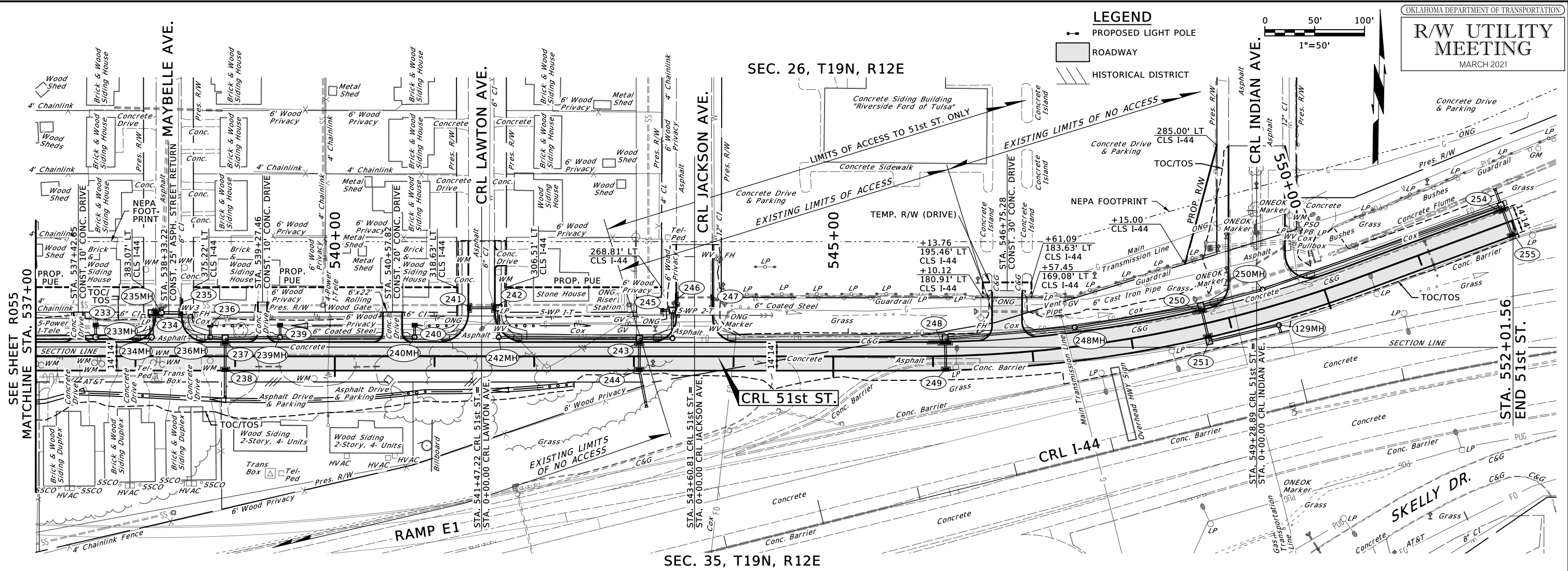
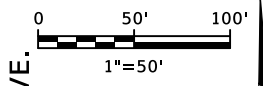

BENCHMARK 129
 RRSPIKE N FACE OF PP
 STA. 134+96.86, 161.00' RT CLS I-44
 STA. 298+96.69, 160.86' RT CRL I-44
 N 402313.10, E 2558890.73, EL. 661.926

BENCHMARK 130
 CUT X ON TC
 STA. 142+81.01, 223.73' RT CLS I-44
 STA. 306+80.86, 223.55' RT CRL I-44
 N 402447.59, E 2559680.06, EL. 669.283

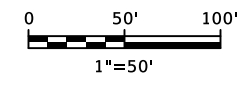

- LEGEND**
- PROPOSED LIGHT POLE
 - ROADWAY
 - HISTORICAL DISTRICT

SEC. 26, T19N, R12E

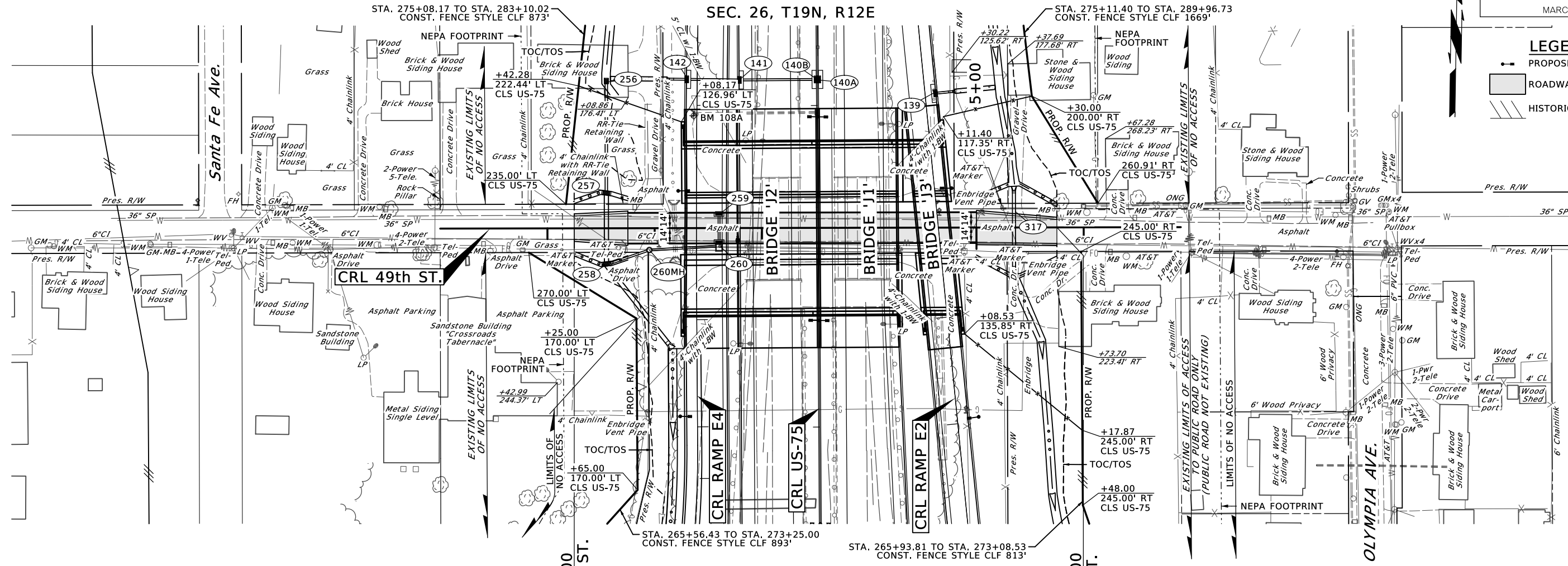

BENCHMARK 108A
CUT X
STA. 275+13.76, 115.40' LT CLS US-75
STA. 583+91.21, 115.56' LT CRL US-75
N 403787.17, E 2557276.90, EL. 682.821

BENCHMARK 108
3/8IPC
STA. 276+99.78, 63.16' LT CLS US-75
STA. 585+77.23, 63.32' LT CRL US-75
N 403974.23, E 2557325.32, EL. 706.998

STA. 1+25.00
BEGIN 49th ST.

STA. 5+75.00
END 49th ST.

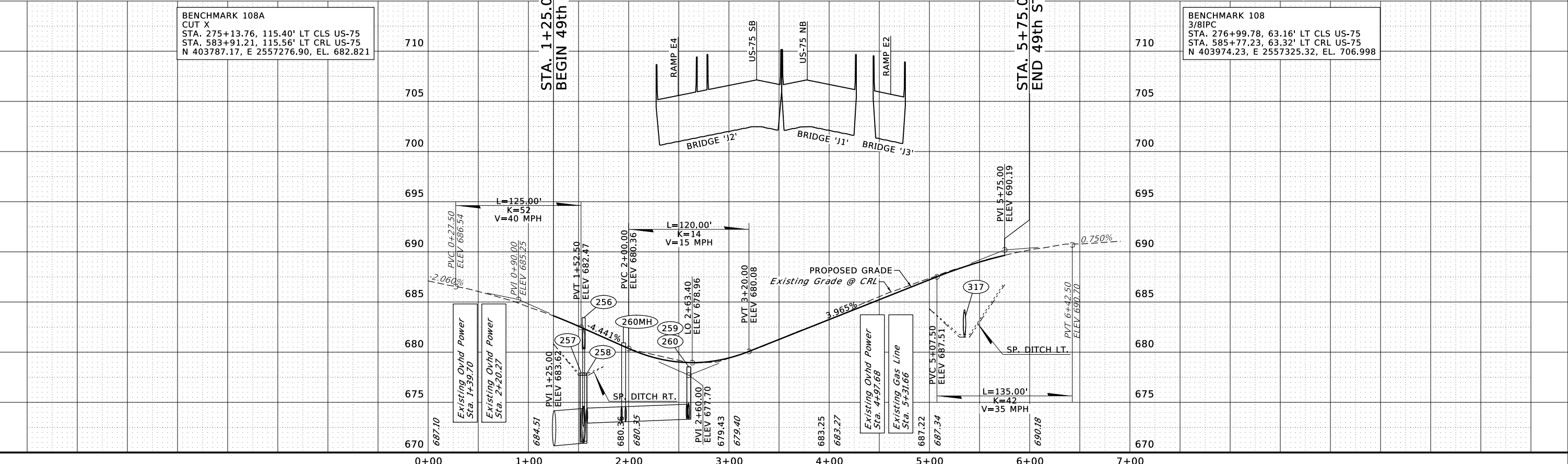
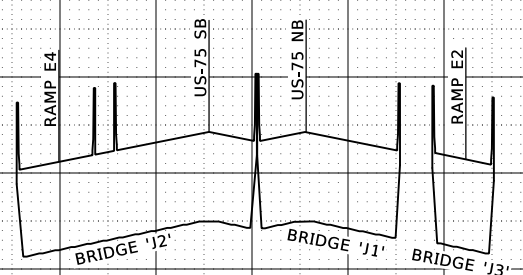

SEC. 26, T19N, R12E

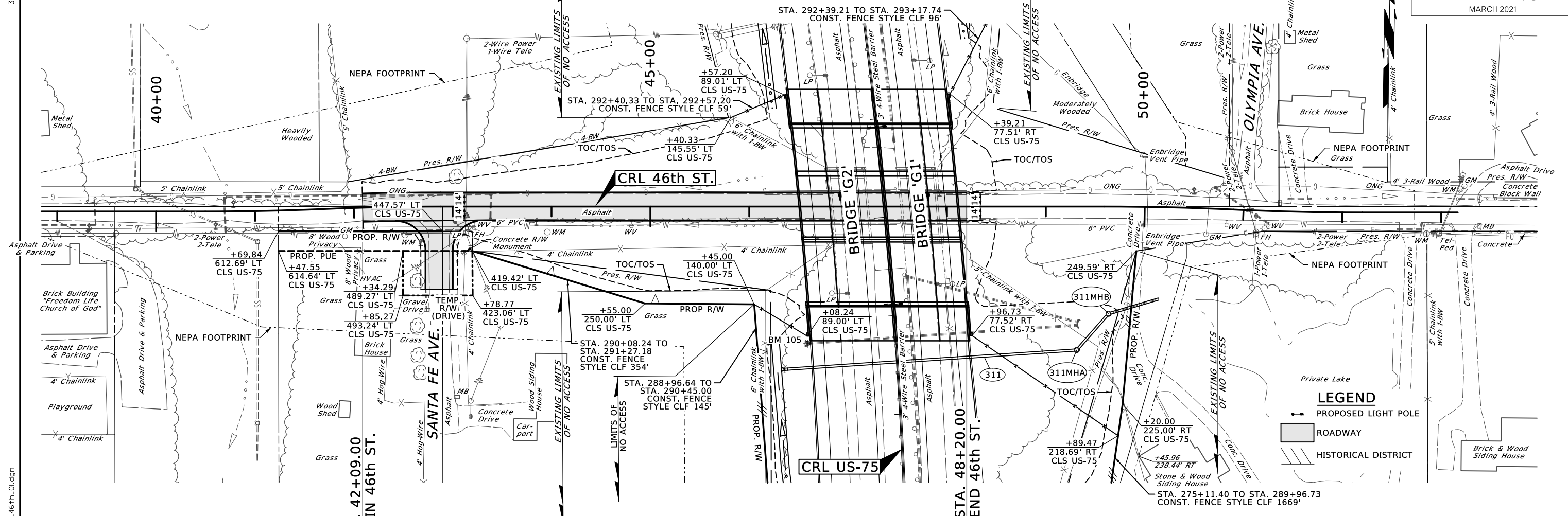
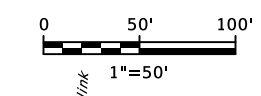

LEGEND

- PROPOSED LIGHT POLE
- ROADWAY
- HISTORICAL DISTRICT

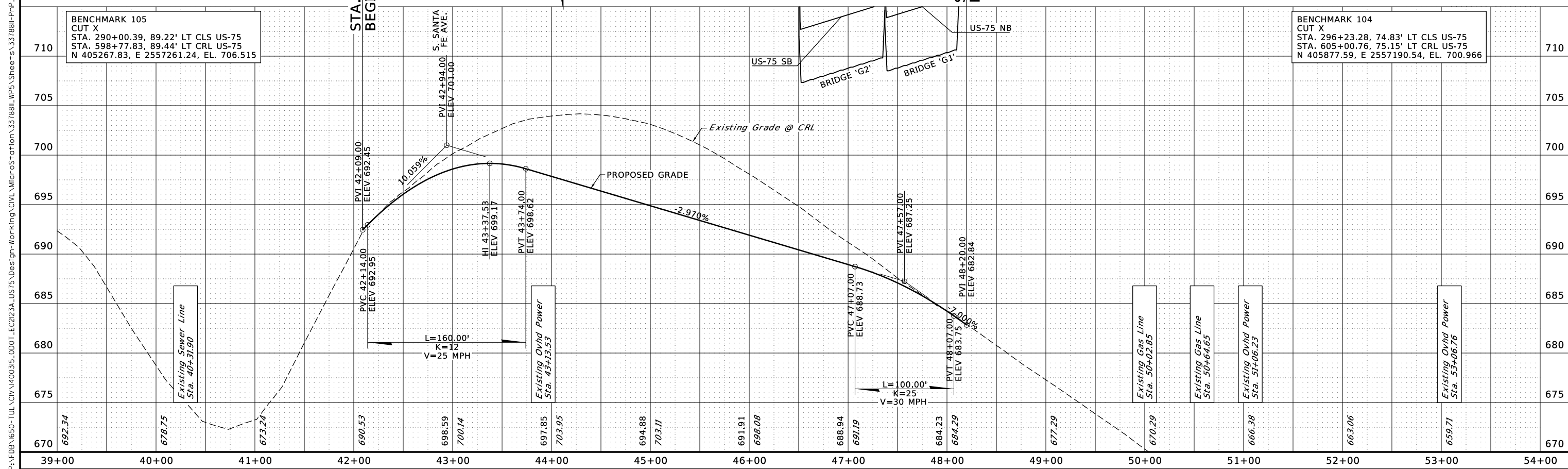

BENCHMARK 105
CUT X
STA. 290+00.39, 89.22' LT CLS US-75
STA. 598+77.83, 89.44' LT CRL US-75
N 405267.83, E 2557261.24, EL. 706.515

BENCHMARK 104
CUT X
STA. 296+23.28, 74.83' LT CLS US-75
STA. 605+00.76, 75.15' LT CRL US-75
N 405877.59, E 2557190.54, EL. 700.966

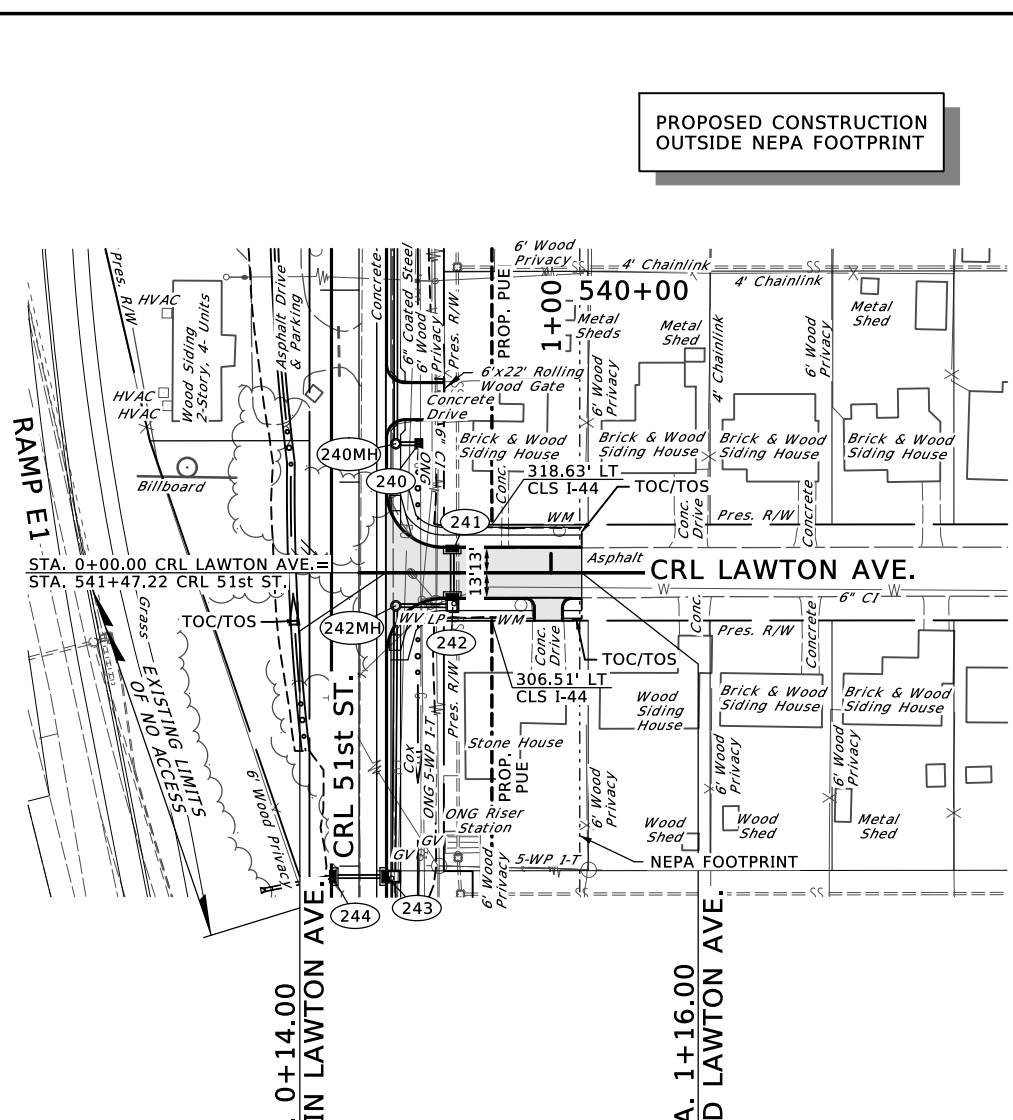
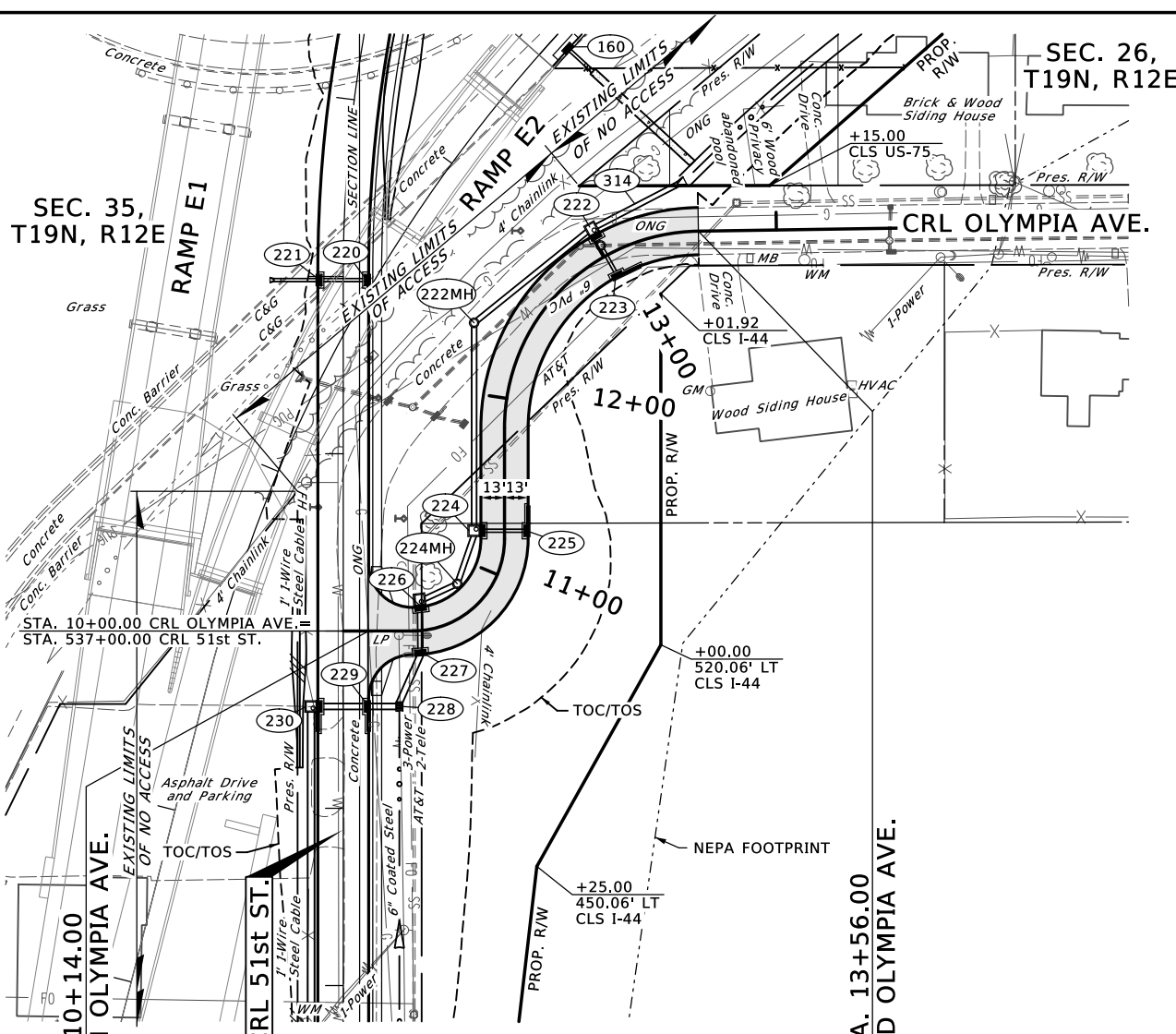
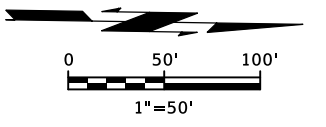

PROPOSED CONSTRUCTION
OUTSIDE NEPA FOOTPRINT

LEGEND

- PROPOSED LIGHT POLE
- ROADWAY
- HISTORICAL DISTRICT

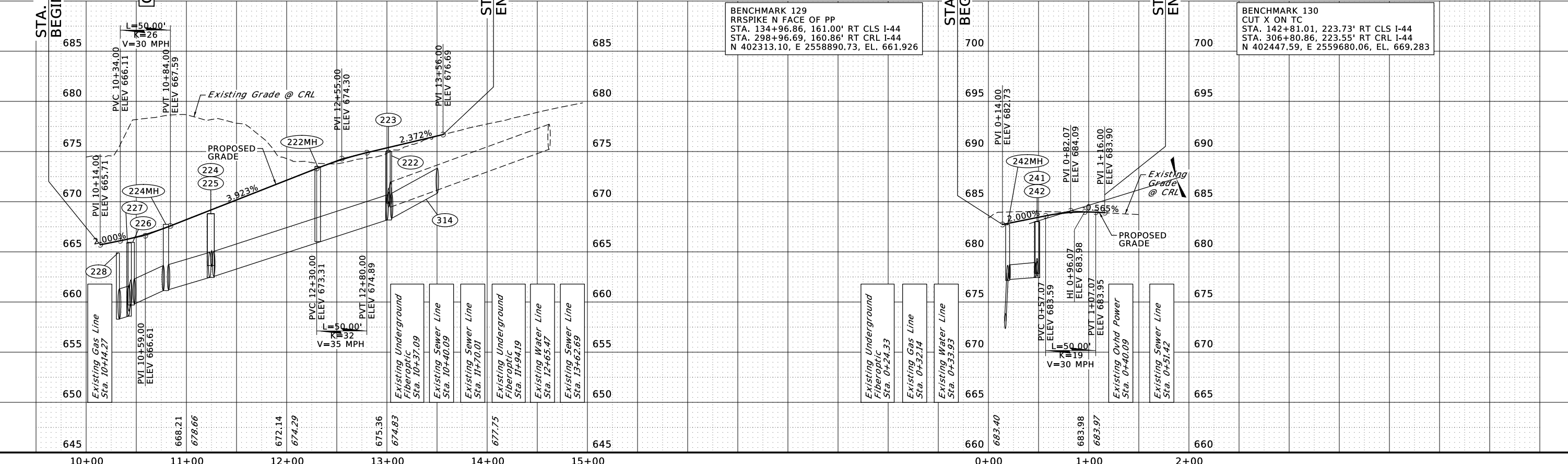

R/W UTILITY MEETING

MARCH 2021

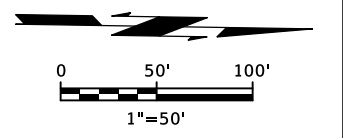

PROPOSED CONSTRUCTION OUTSIDE NEPA FOOTPRINT

- LEGEND**
- PROPOSED LIGHT POLE
 - ROADWAY
 - HISTORICAL DISTRICT

SEC. 35, T19N, R12E SEC. 26, T19N, R12E

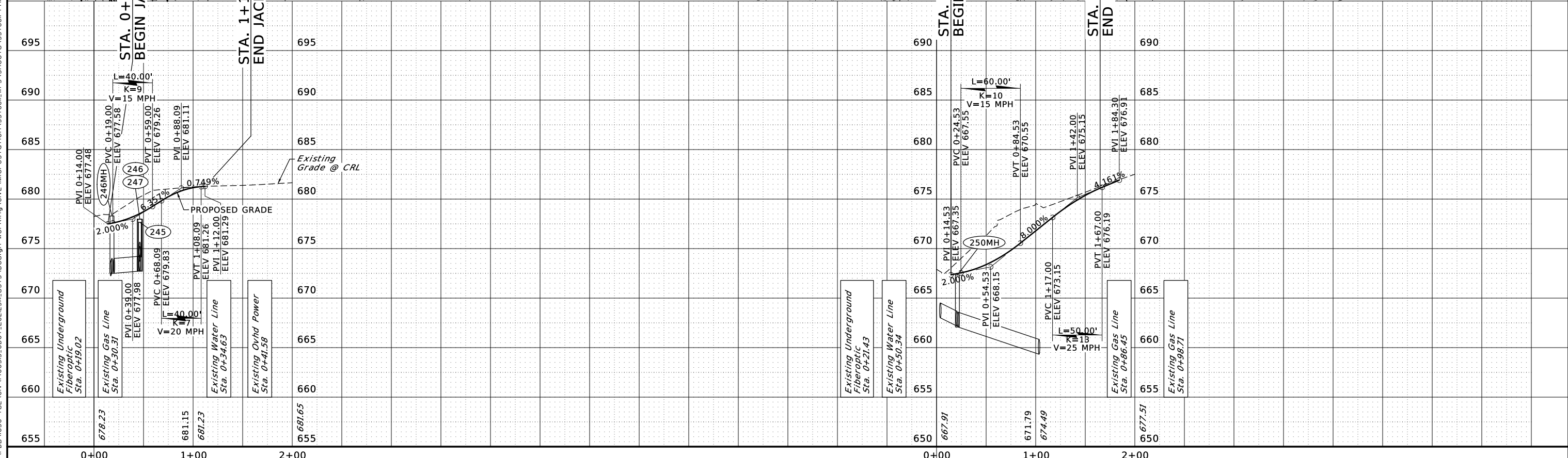
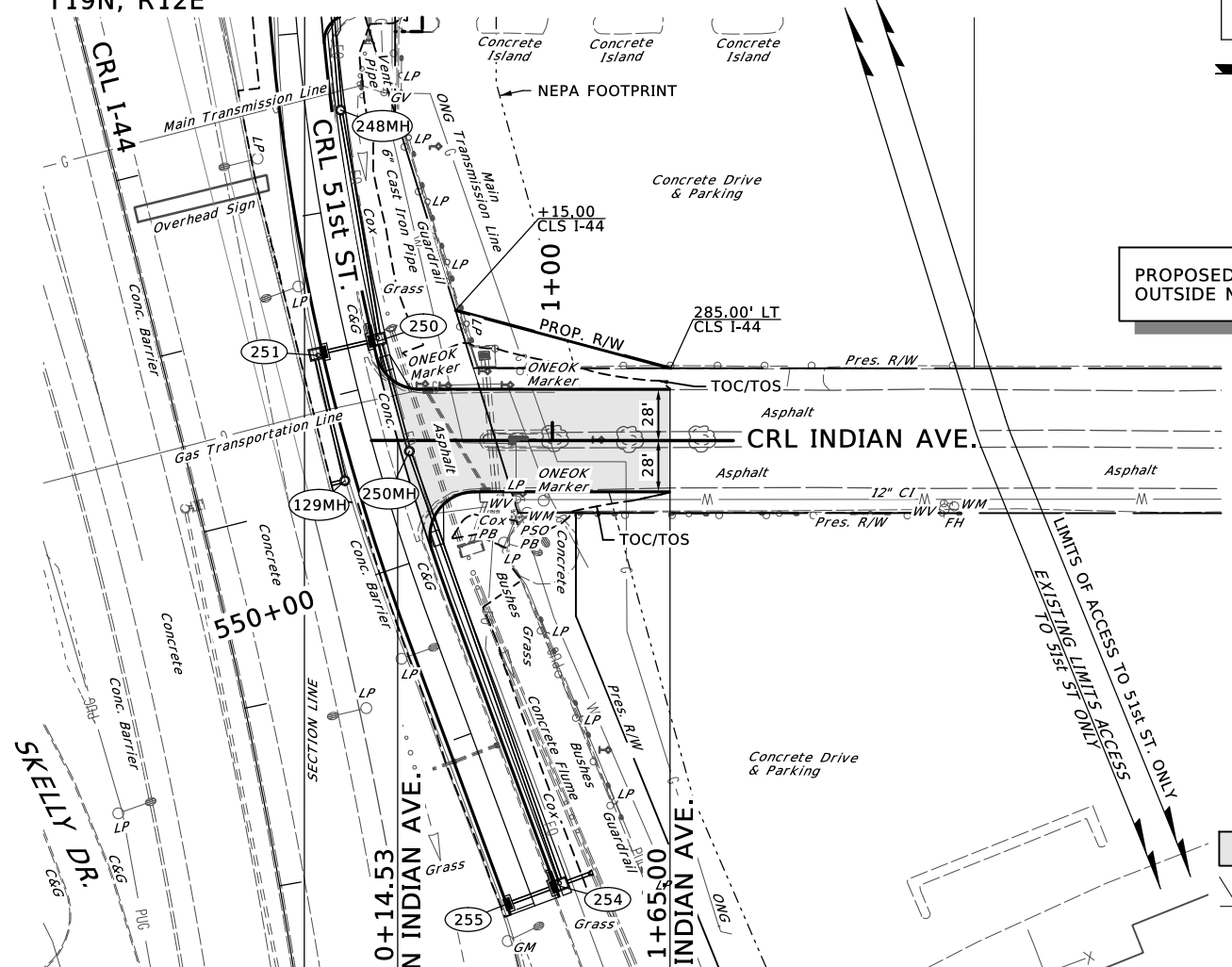
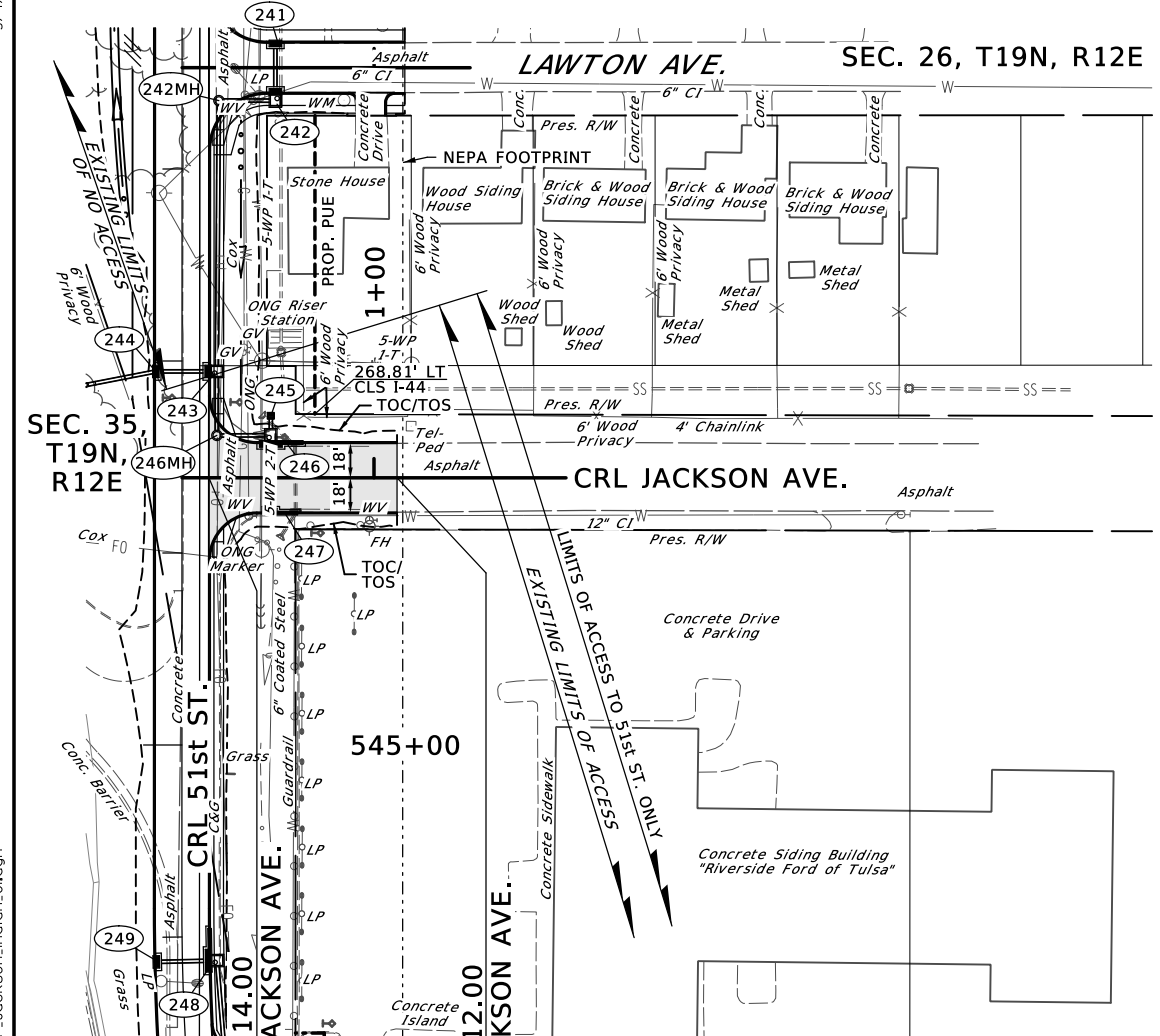

3/4/2021
 P:\FDB\650-TUL\CIV\400315_0001_EC2123A_US75\Design-Work\King\CIV\MicroStation\33788(11)\Sheets\WPS\33788(11)-PnP-Jackson-Indian_01.dgn

SURVEY CONTROL DATA

1. POSITIONAL CONTROL:

- A. POSITIONAL CONTROL FOR THIS SURVEY IS THE NGS OKLAHOMA STATE PLANE COORDINATE SYSTEM, NAD83 (2011), LAMBERT PROJECTION (NORTH ZONE).
- B. ACCURACY - THE POSITIONAL CONTROLS FOR THIS SURVEY MEETS OR EXCEEDS THE FOLLOWING ACCURACY CRITERIA:
 - 1. NETWORK ACCURACY: 0.10 FOOT
 - 2. LOCAL ACCURACY: 0.05 FOOT

2. BEARINGS:

THE BEARINGS SHOWN HEREIN OR HEREON ARE GRID BEARINGS DERIVED FROM THE NGS OKLAHOMA STATE PLANE COORDINATE SYSTEM AND ARE NOT ASTRONOMICAL. THE ANGLE OF VARIANCE BETWEEN GRID NORTH (GN) AND THE ASTRONOMICAL TRUE NORTH (TN) IS DEPICTED DIAGRAMMATICALLY.

3. VERTICAL CONTROLS:

- A. LEVEL DATUM IS NAVD 88 FROM SWO 5117(2) SURVEY CONTROL.
- B. ACCURACY - VERTICAL CONTROL FOR THIS SURVEY MEETS OR EXCEEDS THE FOLLOWING ACCURACY CRITERIA:
 - 1. NETWORK ACCURACY (FROM GPS OR LEVELING): 0.10 FOOT
 - 2. LOCAL ACCURACY (CONFIRMED BY LEVELING): 0.02 FOOT

SURVEY BEGAN: December 1, 2020
SURVEY COMPLETED: June 1, 2020

SURVEY CREW MEMBERS:

SURVEY DATA SHEETS

TULSA COUNTY U.S. 75 SWO 5443(3) STATE JOB NO. 33788(08)(11)

INDEX OF SURVEY SHEETS

S001.	TITLE SHEET
S002-S009.	SURVEY REPORTS
S010-S020.	SURVEY DATA SHEETS
S021-S023.	LAND TIE DATA SHEETS

utility company owner's list

PSO	918-250-6211
COX	405-417-4064
AT&T	918-596-4237
ONG	405-556-6401
CITY OF TULSA	918-596-2595
ONEOK Field services	918-588-7431
Phillips 66	918-977-5143
Enable Midstream	405-921-3582
Enbridge Energy	918-223-2054

"CALL BEFORE YOU DIG"
THE NEW NATIONAL LOCATE NUMBER
811

PROJECT LOCATION

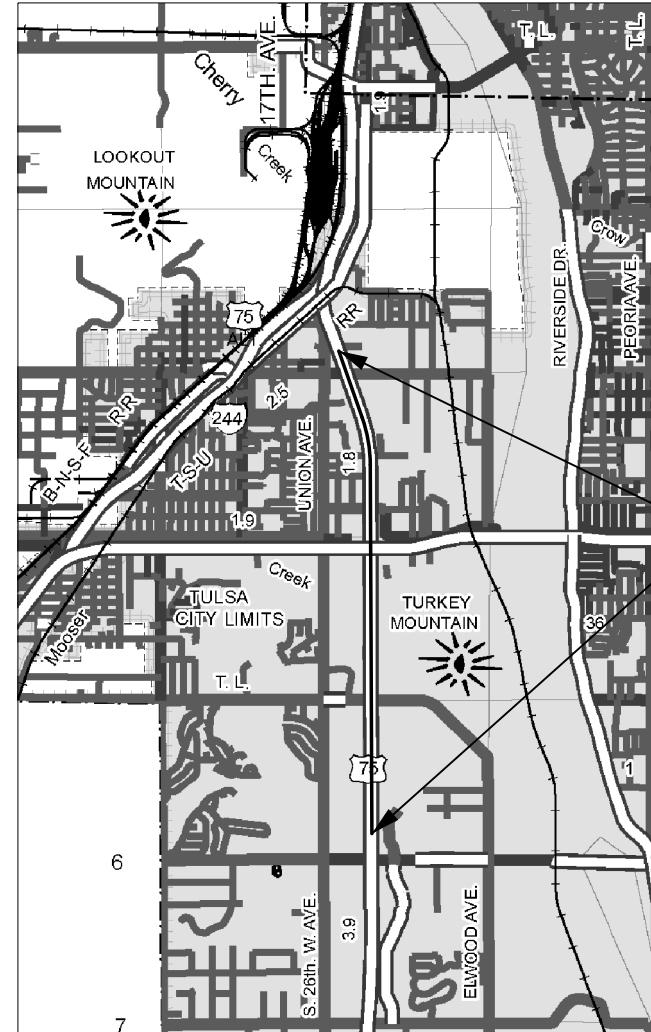

SURVEY EXTENTS

T 19 N

T 18 N

R-12-E

TULSA CO

PROJECT LENGTH 15572.09 F + 2.95 MI.

BEGINNING STATION : 170+00.00
ENDING STATION : 325+72.09

SCALES

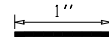

- SURVEY DATA SHEETS 1" = 50' TOWN
- SURVEY DATA SHEETS 1" = 100'
- GEOMETRIC DATA SHEETS 1" = 500'

THIS SURVEY MEETS THE OKLAHOMA MINIMUM STANDARDS FOR THE PRACTICE OF LAND SURVEYING AS ADOPTED BY THE OKLAHOMA STATE BOARD OF REGISTRATION FOR PROFESSIONAL ENGINEERS AND LAND SURVEYORS, JULY 25, 2013.

SPECIFICATIONS FOR SURVEYS FOR PRIMARY AND SECONDARY HIGHWAYS DATED JANUARY, 2018 GOVERN.



Electronic File Transfer Disclaimer:

These Files, Drawings and/or Notes are provided for information only. The Oklahoma Department of Transportation (ODOT) and the Owner cannot be held responsible for the content or accuracy of these Files, Drawings and/or Notes due to conversions, software translations, or any other manipulation of said Files, Drawings and/or Notes. ODOT expressly disclaims any responsibility arising from any use of these Files, Drawings and/or Notes. To the full extent permitted by applicable law, the recipient of these Files, Drawings and/or Notes hereby agrees to defend, indemnify, and hold harmless ODOT and the Owner from and against any and all claims, suits, actions, damages, loss, liability or costs of every nature or description (including reasonable attorney's fees) arising from, or in any way attributable to or connected with any of these Files, Drawings and/or Notes.

DEPARTMENT OF TRANSPORTATION

SWO 5443(3) Job/Piece 33788(08)(11) Engr. Contract No EC-2123A

LAND SURVEYOR'S CERTIFICATION

I hereby certify that all land and property sub-division distances, angles, corners, and monumentation made or used in conjunction with this survey and depicted or recorded herein or hereon were recovered, established or re-established in substantial conformity with:

- Applicable instructions contained in the U.S. Government Bureau of Land Management publication "Manual of Survey Instruction";
- Its supplement, "Restoration of Lost or Obliterated Corners and Sub-division of Sections";
- "Oklahoma Minimum Standards for the Practice of Land Surveying" as adopted by the State Board of Licensure for Professional Engineers and Land Surveyors; and
- Sound land surveying practices;

including a thorough search, study, analysis and consideration of all existing records and field evidence.

I further certify that all survey monuments depicted exist and that all land survey work was done by me or under my direct supervision.

Dated this: 9th Day of June, 2020.

Land Surveyor: *Russell D. Lambillotte*



Russell D. Lambillotte
Printed Name

Oklahoma Licensed Land Surveyor No. 1555

Certificate of Authorization No. CA 7767

PLS	RDL		OKLAHOMA DEPARTMENT OF TRANSPORTATION SURVEY DIVISION
DRAWN	RDL		
CHECKED			
APPROVED			
CREW	ISS		
COUNTY TULSA HIGHWAY US 75 STATE JOB NO. 33788(08)(11) SHEET NO S001			

SURVEY DATA SHEET

SWO 5443(3)

R/W UTILITY MEETING

MARCH 2021

Date: June 16, 2020

To: Mr. Kyle King, Chief of Surveys
Oklahoma Department of Transportation
Survey Division

From: Mr. Russell D. Lambillotte
Oklahoma Professional Land Surveyor #1555

RE: SWO 5443(3), J/P 33788(08)(11), I-44/US 75 Interchange, Work Package #2 and #5.

1. GENERAL HISTORICAL LETTER AND WRITTEN REPORT OF SURVEY

- A. Survey began November 1, 2019
Survey completed June 9, 2020
- B. The measurement unit for this project will be the U.S. Survey Foot

2. ASSIGNMENT

Said survey was assigned to me by Mr. Kyle King, Chief of Surveys, Oklahoma Department of Transportation.

3. PURPOSE

The purpose of this survey is to provide topo and planimetric data for PE Project: EC-2123A;

4. LIMITS

-US 75: The Survey will begin approximately 0.4 miles North of the intersection of W 71st St. and US 75 and extend northerly along US 75 approximately 2.6 miles to just north of the intersection of US 75 and W 41st St.

5. ALIGNMENT

-US 75: The Centerline of Survey for this project was established using field monuments and existing surveys. The alignment matches exactly the alignment established in SWO 5117(2) survey. OHD Brass Caps were found and implemented to establish the remaining alignment.

6. STATIONING

-US 75: Stationing for this project is identical to SWO 5117 (2) with BOP established at Station 170+00.00, which was derived by extending SWO 5117(2) survey south along the project beginning with station increasing to the north.

Historical Letter & Written Report
Page 1 of 3

7. HORIZONTAL CONTROL

- A. This survey is based on control established under the NGS Oklahoma State Plane Coordinate System, NAD 83(2011), Lambert Projection, North Zone, as provided by ODOT from SWO 5117(2) Survey and verified by GPS measurements.
- B. Primary Horizontal Control on this project is from provided control monuments: T-72-1601, T-72-1602, T-72-1704, T-72-1705, T-72-1706
- C. Secondary Horizontal Control was established along the Centerline of Survey, points were set at the Beginning and at the End of the Centerline of Survey and at approx. 300' intervals, points are referenced as shown on Survey Data sheets.
- D. The positional error for any point in the Primary Control Network, Secondary Control Network and all Section Boundaries does not exceed 0.10 foot (Local Accuracy at 95% Confidence). This accuracy will meet or exceed the superseded NGS Second Order, Class II Accuracy Standard (1:20,000).

8. VERTICAL CONTROL

- A. Level datum for this project is NGS, NAVD88 as provided by ODOT. Primary Control point T-72-1601 was used to establish elevation. Check levels were run throughout project and additional Benchmarks were established as shown using a Leica Digital Level and utilizing direct differential leveling techniques. Benchmarks from SWO 5117(2) were included and verified within our survey.
- B. Adjusted levels and vertical differences between benchmarks set are shown.
- C. As a minimum, Benchmarks established are within the closure requirements of NGS Third-Order standards.

9. PHOTO CONTROLS

No Photo Controls will be performed on this project.

10. TOPOGRAPHY

US 75: Topographic and/or Surface Features was provided to us by Frontier Land Surveying, an ODOT sub-consultant working for POE. Isaacs Surveying finalized all topography and surface features for final submittal.

11. DIM

Cross Section data for this survey was collected in the form of aerial Lidar provided by Frontier Land Surveying, an ODOT sub-consultant

Historical Letter & Written Report
Page 2 of 3

working for ODOT as part of Isaacs Surveying Service, LLC contract and was verified for completeness to fill in obscure areas.

12. LAND TIES

There are Land ties included in this survey.

13. EXISTING RIGHT OF WAY

Existing right of way, easements and property ownerships for this survey were obtained from deeds on file with the Tulsa County Clerk and existing SWO 5117(2) survey.

14. UTILITIES

- A. All utility companies servicing the project area were contacted through "CALL OKIE" and the locations were obtained by conventional field methods.
- B. The information was placed in the submitted Microstation Design File and a hardcopy of ODOT form SD-7, List of Public/Private Owned Utilities, was submitted with the completed survey.

15. ENVIRONMENTAL CONCERNS

No areas that could have been used, or that are currently being used to store, or dispose of possible contaminants were found during this survey.

16. DRAINAGE INFORMATION

No Drainage areas were created for this project.

17. PERSONNEL

R.D. Lambillotte	Oklahoma Professional Land Surveyor, Vice President
J.D. Isaacs	Project Manager, Survey/Drafting Technician, President
Steve Steelman	Survey Crew Chief
Casey Ausmus	Survey Crew Chief
John Parks	Survey Technician

18. SURVEY DATA SHEETS

Survey Data Sheets were submitted in the form of a Microstation Design File, as per ODOT Survey Division Standards, to be incorporated into the set of design drawings.

19. SUBMISSION OF SURVEY DATA

- A. Historical Letter and Written Report
- B. Form SD 1 - Transmittal Letter
- C. Form SD 7 - Public and Private Owned Utilities List
- D. (5) Form SD 11 - Position and Description of Project Control Monuments
- E. Form SD 20 - Survey Control Data Statement
- F. Form SD 41 - Surveyors Certificate
- G. Benchmarks and Check Levels List
- H. COGO Data and Alignment Report

Historical Letter & Written Report
Page 3 of 3

PLS	RDL		OKLAHOMA DEPARTMENT OF TRANSPORTATION SURVEY DIVISION
DRAWN	RDL		
CHECKED			
APPROVED			
CREW	ISS		
COUNTY	TULSA	HIGHWAY	US 75
		STATE JOB NO.	33788(08)(11)
		SHEET NO.	S002

SURVEY DATA SHEET

SWO 5443(3)

R/W UTILITY MEETING

MARCH 2021

Table with 5 columns: PTHD, NORTHING, EASTING, ELEVATION, DESCRIPTION. Contains survey data for points 1 through 69.

Table with 5 columns: PTHD, NORTHING, EASTING, ELEVATION, DESCRIPTION. Contains survey data for points 70 through 109A.

Table with 5 columns: PTHD, NORTHING, EASTING, ELEVATION, DESCRIPTION. Contains survey data for points 109B through 324.

Form for Oklahoma Department of Transportation Survey Division, containing fields for PLS, RDL, DRAWN, CHECKED, APPROVED, CREW, COUNTY, and project details like TULSA and US 75.

R/W UTILITY MEETING

MARCH 2021

Table with 3 columns: PTNO, NORTHING, EASTING. Contains survey data points for the left side of the project.

Table with 3 columns: PTNO, NORTHING, EASTING. Contains survey data points for the left side of the project.

Table with 3 columns: PTNO, NORTHING, EASTING. Contains survey data points for the left side of the project.

Table with 3 columns: PTNO, NORTHING, EASTING. Contains survey data points for the left side of the project.

Table with 3 columns: PTNO, NORTHING, EASTING. Contains survey data points for the left side of the project.

Table with 3 columns: PTNO, NORTHING, EASTING. Contains survey data points for the left side of the project.

Table with 3 columns: PTNO, NORTHING, EASTING. Contains survey data points for the left side of the project.

Table with 3 columns: PTNO, NORTHING, EASTING. Contains survey data points for the left side of the project.

Table with 3 columns: PTNO, NORTHING, EASTING. Contains survey data points for the left side of the project.

Table with 3 columns: PTNO, NORTHING, EASTING. Contains survey data points for the right side of the project.

Table with 3 columns: PTNO, NORTHING, EASTING. Contains survey data points for the right side of the project.

Table with 3 columns: PTNO, NORTHING, EASTING. Contains survey data points for the right side of the project.

Table with 3 columns: PTNO, NORTHING, EASTING. Contains survey data points for the right side of the project.

Table with 3 columns: PTNO, NORTHING, EASTING. Contains survey data points for the right side of the project.

Table with 3 columns: PTNO, NORTHING, EASTING. Contains survey data points for the right side of the project.

Table with 3 columns: PTNO, NORTHING, EASTING. Contains survey data points for the right side of the project.

Table with 3 columns: PTNO, NORTHING, EASTING. Contains survey data points for the right side of the project.

Table with 3 columns: PTNO, NORTHING, EASTING. Contains survey data points for the right side of the project.

Form containing project details: OKLAHOMA DEPARTMENT OF TRANSPORTATION SURVEY DIVISION, SURVEY DATA SHEET, SWO 5443(3), COUNTY TULSA, HIGHWAY US 75, STATE JOB NO. 33788(08)(11), SHEET NO. S005.

R/W UTILITY MEETING
MARCH 2021

* BENTLEY HORIZONTAL ALIGNMENT REVIEW
*
* Alignment name: CL US 75 (A003)
* Alignment description:
* Alignment style: Alignment\Geom_Baseline
*

STATION	NORTHING	EASTING
Element: Linear		
BOP(301)170+00.000	392277.972851	2557607.156384
POT(313)180+00.000	394277.762966	2557586.718062
Tangential Direction: N01°10'16.00000"W		
Tangential Length: 1003.000		
Element: Linear		
POT(313)180+00.000	394277.762966	2557586.718062
POT(302)186+50.755	394928.382490	2557573.417713
Tangential Direction: N01°10'16.00000"W		
Tangential Length: 650.755		
Element: Linear		
POT(302)186+50.755	394928.382490	2557573.417713
POT(314)190+00.000	395277.555082	2557566.279740
Tangential Direction: N01°10'16.00000"W		
Tangential Length: 249.245		
Element: Linear		
POT(314)190+00.000	395277.555082	2557566.279740
POT(315)202+00.000	396477.304421	2557541.752755
Tangential Direction: N01°10'16.00000"W		
Tangential Length: 1200.000		
Element: Linear		
POT(315)202+00.000	396477.304421	2557541.752755
POT(303)211+96.949	397474.045576	2557521.377782
Tangential Direction: N01°10'16.00000"W		
Tangential Length: 996.949		
Element: Linear		
POT(303)211+96.949	397474.045576	2557521.377782
POT(316)220+00.000	398276.928429	2557504.964776
Tangential Direction: N01°10'16.00000"W		
Tangential Length: 803.051		
Element: Linear		
POT(316)220+00.000	398276.928429	2557504.964776
POT(317)230+00.000	399276.719545	2557484.526454
Tangential Direction: N01°10'16.00000"W		
Tangential Length: 1000.000		

Element: Linear		
POT(317)230+00.000	399276.719545	2557484.526454
POT(304)238+41.632	400118.176714	2557467.324889
Tangential Direction: N01°10'16.00000"W		
Tangential Length: 841.632		

Element: Linear		
POT(304)238+41.632	400118.176714	2557467.324889
POT(318)240+00.000	400276.510661	2557464.088132
Tangential Direction: N01°10'16.00000"W		
Tangential Length: 158.367		

Element: Linear		
POT(318)240+00.000	400276.510661	2557464.088132
POT(319)250+00.000	401276.301776	2557443.649811
Tangential Direction: N01°10'16.00000"W		
Tangential Length: 1000.000		

Element: Linear		
POT(319)250+00.000	401276.301776	2557443.649811
POT(305)261+35.820	402411.894521	2557420.435556
Tangential Direction: N01°10'16.00000"W		
Tangential Length: 1135.820		

Element: Linear		
POT(305)261+35.820	402411.894521	2557420.435556
POT(306)264+85.888	402761.879173	2557419.280759
Tangential Direction: N01°10'16.00000"W		
Tangential Length: 250.068		

Element: Linear		
POT(306)264+85.888	402761.879173	2557419.280759
POT(320)270+00.000	403275.894008	2557402.773168
Tangential Direction: N01°10'16.00000"W		
Tangential Length: 514.112		

Element: Linear		
POT(320)270+00.000	403275.894008	2557402.773168
POT(321)280+00.000	404275.675123	2557382.334846
Tangential Direction: N01°10'16.00000"W		
Tangential Length: 1000.000		

Element: Linear		
POT(321)280+00.000	404275.675123	2557382.334846
PC(307)286+32.389	404908.931978	2557369.389435
Tangential Direction: N01°10'16.00000"W		
Tangential Length: 622.389		

Element: Circular		
PC(307)286+32.389	404908.931978	2557369.389435
PT(308)296+24.870	405900.005755	2557349.129218
CC()	404791.829021	2551641.008254
PT(309)305+96.517	406826.665820	2556997.079876
Radius: 5729.578		
Delta: 19°37'52.617" Left		
Degree of Curvature(Arc): 02°16'51.000"		
Length: 1963.128		
Tangent: 991.281		
Chord: 1953.540		
Middle Ordinate: 83.873		
External: 85.119		
Tangent Direction: N01°10'16.00000"W		
Radial Direction: N88°49'44.00000"E		
Chord Direction: N10°59'12.30870"W		
Radial Direction: N69°11'51.38261"E		
Tangent Direction: N20°48'08.61739"W		

Element: Linear		
PT(309)305+96.517	406826.665820	2556997.079876
POT(323)310+00.000	407203.845702	2556853.784651
Tangential Direction: N20°48'08.61739"W		
Tangential Length: 403.482		

Element: Linear		
POT(323)310+00.000	407203.845702	2556853.784651
POT(311)318+99.224	408044.449987	2556534.428850
Tangential Direction: N20°48'08.61739"W		
Tangential Length: 899.224		

Element: Linear		
POT(311)318+99.224	408044.449987	2556534.428850
POT(324)319+25.551	408069.060600	2556525.078979
Tangential Direction: N20°48'08.61739"W		
Tangential Length: 26.327		

Element: Linear		
POT(324)319+25.551	408069.060600	2556525.078979
EOP(312)325+72.094	408673.456428	2556295.461646
Tangential Direction: N20°48'08.61739"W		
Tangential Length: 646.542		

PLS	RDL		OKLAHOMA DEPARTMENT OF TRANSPORTATION SURVEY DIVISION
DRAWN	RDL		
CHECKED			
APPROVED			
CREW	ISS		
COUNTY	TULSA	HIGHWAY	US 75
		STATE JOB NO.	33788(08)(11)
		SHEET NO.	S006

SURVEY DATA SHEET

SWO 5443(3)

R/W UTILITY MEETING

MARCH 2021

CHECK LEVELS THROUGH PROJECT CONTROL							BENCH MARK LIST	
SW05443_BM1.xlsx							NAVD 88 DATUM	
BM No.	Run 1	Run 2	Mean Diff.	Unadj. Elev.	Adj. Elev.	Published Elev.	BM Description	
T-72-1601				706.04		706.04	N. 403766.132 E. 2557392.970 2IN ALUMINUM CAP IN CONCRETE POST STA 274+90.35 0.22' RT CL US-75 (A003)	
to TP 6	11.800	11.800	11.800	694.240			TEMPORARY TURN POINT - LOCATION NOT DESCRIBED	
to T-72-1602	12.510	12.510	12.510	681.730		681.73	N. 402864.778 E. 2557317.738 2IN ALUMINUM CAP IN CONCRETE POST STA 265+90.72 93.42' LT CL US-75 (A003)	
to TP 7	10.110	10.111	10.111	671.620			TEMPORARY TURN POINT - LOCATION NOT DESCRIBED	
to BM 110	-2.321	-2.320	-2.320	673.940			N. 402773.164 E. 2556827.839 RR SPIKE IN SE FACE OF PP STA 114+65.27 370.54' LT CL I-44 (A001)	
to TP 8	11.500	11.503	11.503	662.438			TEMPORARY TURN POINT - LOCATION NOT DESCRIBED	
to BM 111	9.857	9.857	9.857	652.581			N. 402270.704 E. 2556706.127 CUT BOX AT EAST SIDE OF CONCRETE BASE FOR LIGHT POLE STA 113+35.68 129.94' RT CL I-44 (A001)	

CHECK LEVELS THROUGH PROJECT CONTROL							BENCH MARK LIST	
SW05443_BM2.xlsx							NAVD 88 DATUM	
BM No.	Run 1	Run 2	Mean Diff.	Unadj. Elev.	Adj. Elev.	Published Elev.	BM Description	
to BM 114	-5.749	-5.744	-5.747	734.472			N. 399737.162 E. 2557398.790 CUT X AT WEST TOE OF CONCRETE FLUME STA 234+62.10 76.31' LT CL US-75 (A003)	
to TP 8	-12.093	-12.089	-12.091	746.563			TEMPORARY TURN POINT - LOCATION NOT DESCRIBED	
to BM 115	-8.987	-8.991	-8.989	755.552			N. 399150.361 E. 2557412.085 CUT X AT WEST EDGE OF WEST CONCRETE BASE FOR EXIT SIGN STA 228+75.15 75.01' LT CL US-75 (A003)	
to BM 116A	-4.683	-4.683	-4.683	760.235			N. 399011.652 E. 2557426.859 CUT V IN CENTER OF SLOPED FACE OF RCP STRUCTURE STA 227+36.17 63.07' LT CL US-75 (A003)	
to TP 9	-9.482	-9.478	-9.480	769.715			TEMPORARY TURN POINT - LOCATION NOT DESCRIBED	
to BM 116B	-1.717	-1.719	-1.718	771.433			N. 398335.748 E. 2557401.431 CUT X AT CENTER OF RCB STA 220+60.92 102.31' LT CL US-75 (A003)	
to TP 10	-9.317	-9.317	-9.317	780.750			TEMPORARY TURN POINT - LOCATION NOT DESCRIBED	
to TP 11	-8.831	-8.829	-8.830	789.580			TEMPORARY TURN POINT - LOCATION NOT DESCRIBED	
to BM 117	-0.416	-0.416	-0.416	789.996			N. 397547.565 E. 2557203.225 RR SPIKE IN SE FACE OF POWER POLE STA 212+76.96 316.58' LT CL US-75 (A003)	
to TP 12	-1.439	-1.439	-1.439	791.435			TEMPORARY TURN POINT - LOCATION NOT DESCRIBED	

CHECK LEVELS THROUGH PROJECT CONTROL							BENCH MARK LIST	
SW05443_BM2.xlsx							NAVD 88 DATUM	
BM No.	Run 1	Run 2	Mean Diff.	Unadj. Elev.	Adj. Elev.	Published Elev.	BM Description	
BM 111				652.581		652.581	N. 402270.704 E. 2556706.127 CUT BOX AT EAST SIDE OF CONCRETE BASE FOR LIGHT POLE STA 113+35.68 129.94' RT CL I-44 (A001)	
to TP 1	-5.388	-5.392	-5.390	657.971			TEMPORARY TURN POINT - LOCATION NOT DESCRIBED	
to TP 2	-11.540	-11.553	-11.547	669.518			TEMPORARY TURN POINT - LOCATION NOT DESCRIBED	
to BM 112	-5.404	-5.399	-5.402	674.919			N. 401507.902 E. 2557360.663 CUT BOX AT WEST EDGE OF CONCRETE BASE FOR LIGHT POLE STA 252+33.25 78.24' LT CL US-75 (A003)	
to TP 3	-11.104	-11.105	-11.105	686.024			TEMPORARY TURN POINT - LOCATION NOT DESCRIBED	
to TP 4	-9.399	-9.395	-9.397	695.421			TEMPORARY TURN POINT - LOCATION NOT DESCRIBED	
to TP 5	-10.079	-10.079	-10.079	705.500			TEMPORARY TURN POINT - LOCATION NOT DESCRIBED	
to BM 113	-1.028	-1.027	-1.028	706.527			N. 400634.147 E. 2557382.671 CUT X AT WEST EDGE OF CONCRETE BASE FOR LIGHT POLE STA 243+59.23 74.09' LT CL US-75 (A003)	
to TP 6	-11.086	-11.091	-11.089	717.616			TEMPORARY TURN POINT - LOCATION NOT DESCRIBED	
to TP 7	-11.108	-11.111	-11.110	728.725			TEMPORARY TURN POINT - LOCATION NOT DESCRIBED	

CHECK LEVELS THROUGH PROJECT CONTROL							BENCH MARK LIST	
SW05443_BM2.xlsx							NAVD 88 DATUM	
BM No.	Run 1	Run 2	Mean Diff.	Unadj. Elev.	Adj. Elev.	Published Elev.	BM Description	
to BM 118	-5.345	-5.344	-5.345	796.779			N. 397008.522 E. 2557338.546 #5 REBAR WITH 3IN. ALUMINUM CAP STA 207+35.26 192.31' LT CL US-75 (A003)	
to TP 13	11.039	11.040	11.040	785.740			TEMPORARY TURN POINT - LOCATION NOT DESCRIBED	
to BM 119	8.900	8.894	8.897	776.843			N. 396526.601 E. 2557430.688 CUT X AT CENTER OF HEADWALL STA 202+51.56 110.04' LT CL US-75 (A003)	
to TP 14	-8.327	-8.324	-8.326	785.168			TEMPORARY TURN POINT - LOCATION NOT DESCRIBED	
to BM 120	-1.701	-1.697	-1.699	786.867			N. 395797.510 E. 2557495.601 PK NAIL SET 1FT FROM WEST EDGE OF ASPHALT IN LINE WITH EXIT SIGN STA 195+21.29 60.04' LT CL US-75 (A003)	
to TP 15	-2.163	-2.165	-2.164	789.031			TEMPORARY TURN POINT - LOCATION NOT DESCRIBED	
to BM 121	-0.766	-0.766	-0.766	789.797			N. 395017.227 E. 2557478.868 CUT X ON WEST EDGE OF CONCRETE BASE FOR SIGN STA 187+41.51 92.71' LT CL US-75 (A003)	
to BM 122	6.286	6.289	6.287	783.510			N. 394804.718 E. 2557449.939 CUT X TOP OF 38IN RCP PIPE STA 185+29.64 125.98' LT CL US-75 (A003)	
to TP 16	-10.533	-10.534	-10.534	794.043			TEMPORARY TURN POINT - LOCATION NOT DESCRIBED	
to BM 123	3.797	3.795	3.796	790.247			N. 394082.103 E. 2557393.180 #5 REBAR WITH 2IN. ALUMINUM CAP STA 178+08.34 197.5' LT CL US-75 (A003)	

PLS	RDL	
DRAWN	RDL	
CHECKED		
APPROVED		
CREW	ISS	
COUNTY	TULSA	

OKLAHOMA DEPARTMENT OF TRANSPORTATION
SURVEY DIVISION

SURVEY DATA SHEET

SWO 5443(3)

R/W UTILITY MEETING
MARCH 2021

CHECK LEVELS THROUGH PROJECT CONTROL							BENCH MARK LIST	
SW05443_BM3.xlsx							NAVD 88 DATUM	
BM No.	Run 1	Run 2	Mean Diff.	Unadj. Elev.	Adj. Elev.	Published Elev.	BM Description	
BM 111				652.581		652.581	N. 402270.704 E. 2556706.127 CUT BOX AT EAST SIDE OF CONCRETE BASE FOR LIGHT POLE STA 113+35.68 129.94' RT CL I-44 (A001)	
to TP 17	-9.859	-9.858	-9.858	662.440			TEMPORARY TURN POINT - LOCATION NOT DESCRIBED	
to BM 110	-11.505	-11.502	-11.504	673.943			N. 402773.164 E. 2556827.899 RR SPIKE IN SE FACE OF PP STA 114+65.27 370.54' LT CL I-44 (A001)	
to TP 18	2.343	2.341	2.342	671.601			TEMPORARY TURN POINT - LOCATION NOT DESCRIBED	
to TP 19	-10.783	-10.784	-10.784	682.385			TEMPORARY TURN POINT - LOCATION NOT DESCRIBED	
to BM 109	-11.035	-11.032	-11.034	693.418			N. 403320.018 E. 2557343.580 CUT X IN CENTER OF CONC ISLAND STA 270+45.33 58.28' LT CL US-75 (A003)	
to TP 20	-4.746	-4.747	-4.746	698.165			TEMPORARY TURN POINT - LOCATION NOT DESCRIBED	
to BM 108	-8.833	-8.835	-8.834	706.999			N. 403974.229 E. 2557325.324 #3 REBAR W/ CA 7767 PLASTIC CAP STA 276+99.78 63.16' LT CL US-75 (A003)	
to TP 21	-2.169	-2.168	-2.168	709.167			TEMPORARY TURN POINT - LOCATION NOT DESCRIBED	
to BM 107	7.689	7.686	7.687	701.480			N. 404476.975 E. 2557239.457 #5 REBAR WITH 2IN. ALUMINUM CAP STA 282+04.18 138.73' LT CL US-75 (A003)	

CHECK LEVELS THROUGH PROJECT CONTROL							BENCH MARK LIST	
SW05443_BM3.xlsx							NAVD 88 DATUM	
BM No.	Run 1	Run 2	Mean Diff.	Unadj. Elev.	Adj. Elev.	Published Elev.	BM Description	
to TP 27	6.558	6.562	6.560	653.110			TEMPORARY TURN POINT - LOCATION NOT DESCRIBED	
to TP 28	9.097	9.099	9.098	644.012			TEMPORARY TURN POINT - LOCATION NOT DESCRIBED	
to BM 101	12.467	12.461	12.464	631.548			N. 407498.372 E. 2556571.824 CUT X AT NE CORNER OF HEADWALL STA 313+75.46 158.98' LT CL US-75 (A003)	
to TP 29	-9.683	-9.691	-9.687	641.235			TEMPORARY TURN POINT - LOCATION NOT DESCRIBED	
to TP 30	4.607	4.609	4.608	636.627			TEMPORARY TURN POINT - LOCATION NOT DESCRIBED	
to BM 100	1.714	1.709	1.712	634.915			N. 408100.004 E. 2556351.136 CUT X ON WEST SIDE OF HEADWALL STA 320+16.25 151.61' LT CL US-75 (A003)	
to SCP 1A	-2.904	-2.907	-2.906	637.821			TEMPORARY TURN POINT - LOCATION NOT DESCRIBED	

CHECK LEVELS THROUGH PROJECT CONTROL							BENCH MARK LIST	
SW05443_BM3.xlsx							NAVD 88 DATUM	
BM No.	Run 1	Run 2	Mean Diff.	Unadj. Elev.	Adj. Elev.	Published Elev.	BM Description	
to BM 106	0.220	0.213	0.217	701.263			N. 404555.567 E. 2557267.573 CUT X AT CENTER OF HEADWALL STA 282+82.18 109.02' LT CL US-75 (A003)	
to TP 22	-6.921	-6.918	-6.920	708.183			TEMPORARY TURN POINT - LOCATION NOT DESCRIBED	
to BM 105	1.667	1.668	1.668	706.515			N. 405267.832 E. 2557261.244 CUT X AT CENTER OF HEADWALL STA 290+00.39 89.22' LT CL US-75 (A003)	
to TP 23	-4.473	-4.467	-4.470	710.985			TEMPORARY TURN POINT - LOCATION NOT DESCRIBED	
to BM 104	10.017	10.020	10.019	700.967			N. 405877.591 E. 2557190.540 CUT X AT NW CORNER OF HEADWALL STA 296+23.28 74.83' LT CL US-75 (A003)	
to BM 103	9.225	9.229	9.227	691.740			N. 406141.877 E. 2557003.281 #5 REBAR WITH 2IN. ALUMINUM CAP STA 299+29.43 199.97' LT CL US-75 (A003)	
to TP 24	4.411	4.404	4.407	687.332			TEMPORARY TURN POINT - LOCATION NOT DESCRIBED	
to TP 25	7.984	7.977	7.981	679.352			TEMPORARY TURN POINT - LOCATION NOT DESCRIBED	
to BM 102	9.421	9.418	9.419	669.932			N. 406818.819 E. 2556925.263 CUT X AT WEST EDGE OF CONCRETE BASE FOR LIGHT POLE STA 306+14.69 69.92' LT CL US-75 (A003)	
to TP 26	10.262	10.263	10.263	659.670			TEMPORARY TURN POINT - LOCATION NOT DESCRIBED	

PLS	RDL		OKLAHOMA DEPARTMENT OF TRANSPORTATION SURVEY DIVISION
DRAWN	RDL		
CHECKED			
APPROVED			
CREW	ISS		
COUNTY TULSA HIGHWAY US 75 STATE JOB NO. 33788(08)(11) SHEET NO. S008			<p align="center">SURVEY DATA SHEET</p> <p align="center">SWO 5443(3)</p>

R/W UTILITY MEETING

MARCH 2021

3/4/2021

F:\FDB\1650-TUL\CIV\400315_000T_EC2123A_US75\Design-Working\Civil\MicroStation\337888\WP5\Sheets\337888-Survey_09.dgn

CHECK LEVELS THROUGH PROJECT CONTROL
SW05443_BM4.xlsx

BENCH MARK LIST
NAVD 88 DATUM

BM No.	Run 1	Run 2	Mean Diff.	Unadj. Elev.	Adj. Elev.	Published Elev.	BM Description
BM 111				652.581		652.581	N. 402270.704 E. 2556706.127 CUT BOX AT EAST SIDE OF CONCRETE BASE FOR LIGHT POLE STA 113+35.68 129.94' RT CL-44 (A001)
to	4.811	4.803	4.807				
BM 127A				647.774			N. 402277.282 E. 2557167.476 CUT X ON HEADWALL STA 117+97.08 130.61' RT CL-44 (A001)
to	1.929	1.929	1.929				
BM 127B				645.845			N. 402280.258 E. 2557285.446 CUT X ON WEST END OF HEADWALL STA 119+15.21 121.49' RT CL-44 (A001)
to	0.387	0.386	0.386				
BM 127C				645.459			N. 402254.291 E. 2557296.140 CUT X ON CL HEADWALL STA 119+25.36 155.62' RT CL-44 (A001)
to	-9.414	-9.414	-9.414				
TP 4				654.873			TEMPORARY TURN POINT - LOCATION NOT DESCRIBED
to	5.304	5.304	5.304				
BM 127D				649.569			N. 402310.301 E. 2557566.829 CUT X AT CENTER OF HEADWALL STA 121+96.83 103.87' RT CL-44 (A001)
to	-5.918	-5.917	-5.918				
TP 5				655.486			TEMPORARY TURN POINT - LOCATION NOT DESCRIBED
to	-2.418	-2.419	-2.418				
BM 128				657.905			N. 402330.919 E. 2558178.734 CUT X ON NORTH SIDE OF CONCRETE BASE FOR LIGHT POLE STA 128+09.05 92.87' RT CL-44 (A001)
to	-3.060	-3.064	-3.062				
TP 6				660.967			TEMPORARY TURN POINT - LOCATION NOT DESCRIBED
to	-0.960	-0.961	-0.960				
BM 129				661.927			N. 402313.101 E. 2558890.728 RR SPIKE IN NORTH FACE OF PP STA 134+96.86 161' RT CL-44 (A001)
to	-6.547	-6.546	-6.546				
TP 7				668.474			TEMPORARY TURN POINT - LOCATION NOT DESCRIBED

CHECK LEVELS THROUGH PROJECT CONTROL
SW05443_BM4.xlsx

BENCH MARK LIST
NAVD 88 DATUM

BM No.	Run 1	Run 2	Mean Diff.	Unadj. Elev.	Adj. Elev.	Published Elev.	BM Description
to	-0.809	-0.811	-0.810				
BM 130				669.284			N. 402447.592 E. 2559680.063 CUT X ON TOP OF CURB STA 142+81.01 223.73' RT CL-44 (A001)
to	5.054	5.057	5.055				
TP 8				664.228			TEMPORARY TURN POINT - LOCATION NOT DESCRIBED
to	5.324	5.326	5.325				
BM 131				658.903			N. 402709.264 E. 2560461.239 CUT X ON TOP OF CURB STA 151+28.13 98.39' RT CL-44 (A002)
to	11.111	11.142	11.127				
TP 9				647.777			TEMPORARY TURN POINT - LOCATION NOT DESCRIBED
to	9.755	9.754	9.754				
TP 10				638.022			TEMPORARY TURN POINT - LOCATION NOT DESCRIBED
to	6.673	6.673	6.673				
BM 132				631.349			N. 402691.458 E. 2560896.515 CUT X ON EAST END OF HEADWALL STA 155+66.54 124.62' RT CL-44 (A002)
to	5.002	4.992	4.997				
TP 11				626.352			TEMPORARY TURN POINT - LOCATION NOT DESCRIBED
to	-1.812	-1.811	-1.812				
BM 133				628.164			N. 402657.907 E. 2561653.679 CUT X ON NORTH EDGE OF LAMP POLE STA 163+22.25 171.91' RT CL-44 (A002)
to	-8.620	-8.620	-8.620				
TP 12				636.784			TEMPORARY TURN POINT - LOCATION NOT DESCRIBED
to	-11.420	-11.420	-11.420				
TP 13				648.204			TEMPORARY TURN POINT - LOCATION NOT DESCRIBED
to	-8.190	-8.190	-8.190				
T-72-1706				656.394		656.42	N. 402962.936 E. 2560885.957 3IN ALUM CAP BENNETT CONTROL STA 155+60.19 146.99' LT CL-44 (A002)

CHECK LEVELS THROUGH PROJECT CONTROL
SW05443_BM5.xlsx

BENCH MARK LIST
NAVD 88 DATUM

BM No.	Run 1	Run 2	Mean Diff.	Unadj. Elev.	Adj. Elev.	Published Elev.	BM Description
BM 111				652.581		652.581	N. 402270.704 E. 2556706.127 CUT BOX AT EAST SIDE OF CONCRETE BASE FOR LIGHT POLE STA 113+35.68 129.94' RT CL-44 (A001)
to	-5.830	-5.827	-5.829				
TP 1				658.410			TEMPORARY TURN POINT - LOCATION NOT DESCRIBED
to	-11.141	-11.143	-11.142				
T-72-1704				669.552		669.59	N. 402253.939 E. 2556122.416 3IN ALUM CAP BENNETT CONTROL STA 107+51.84 137.52' RT CL-44 (A001)
to	-0.397	-0.401	-0.399				
TP 2				669.951			TEMPORARY TURN POINT - LOCATION NOT DESCRIBED
to	4.176	4.179	4.177				
BM 125				665.773			N. 402121.990 E. 2555421.017 CUT X ON TOP OF CURB STA 100+47.34 256.28' RT CL-44 (A001)
to	-1.935	-1.935	-1.935				
SCP 11				667.708			TEMPORARY TURN POINT - LOCATION NOT DESCRIBED
to	-1.065	-1.059	-1.062				
BM 124				668.770			N. 402187.090 E. 2554725.367 CUT X ON TOP OF CURB STA 93+53.11 177.41' RT CL-44 (A001)
to	-2.319	-2.319	-2.319				
TP 3				671.089			TEMPORARY TURN POINT - LOCATION NOT DESCRIBED
to	-3.756	-3.756	-3.756				
TP 4				674.845			TEMPORARY TURN POINT - LOCATION NOT DESCRIBED
to	-0.435	-0.436	-0.435				
TP 5				675.281			TEMPORARY TURN POINT - LOCATION NOT DESCRIBED
to	5.587	5.586	5.587				
T-72-1604				669.694		669.70	N. 402224.468 E. 2553026.547 3IN ALUM CAP BENNETT CONTROL Offsite

PLS	RDL		OKLAHOMA DEPARTMENT OF TRANSPORTATION SURVEY DIVISION
DRAWN	RDL		
CHECKED			
APPROVED			
CREW	ISS		
COUNTY	TULSA	HIGHWAY	US 75
		STATE JOB NO.	33788(08)(11)
		SHEET NO.	S009

SURVEY DATA SHEET
SWO 5443(3)

3/4/2021
F:\FDB\1650-TUL\CIV\40035_000T_EC2\23A_US75\Design-Working\CIVL\MicroStation\337888\WP5\Sheets\337888II-Survey_10.dgn

SECTION 2
T-18-N, R-12-E
PART SW/4

SECTION 2
T-18-N, R-12-E
PART SW/4

YOUNT, FLOYD L. AND OJEDA G.
BK 2886, PG 127

ONEOK INC C/O KANSAS GAS SERVICE
BK 5878, PG 2255

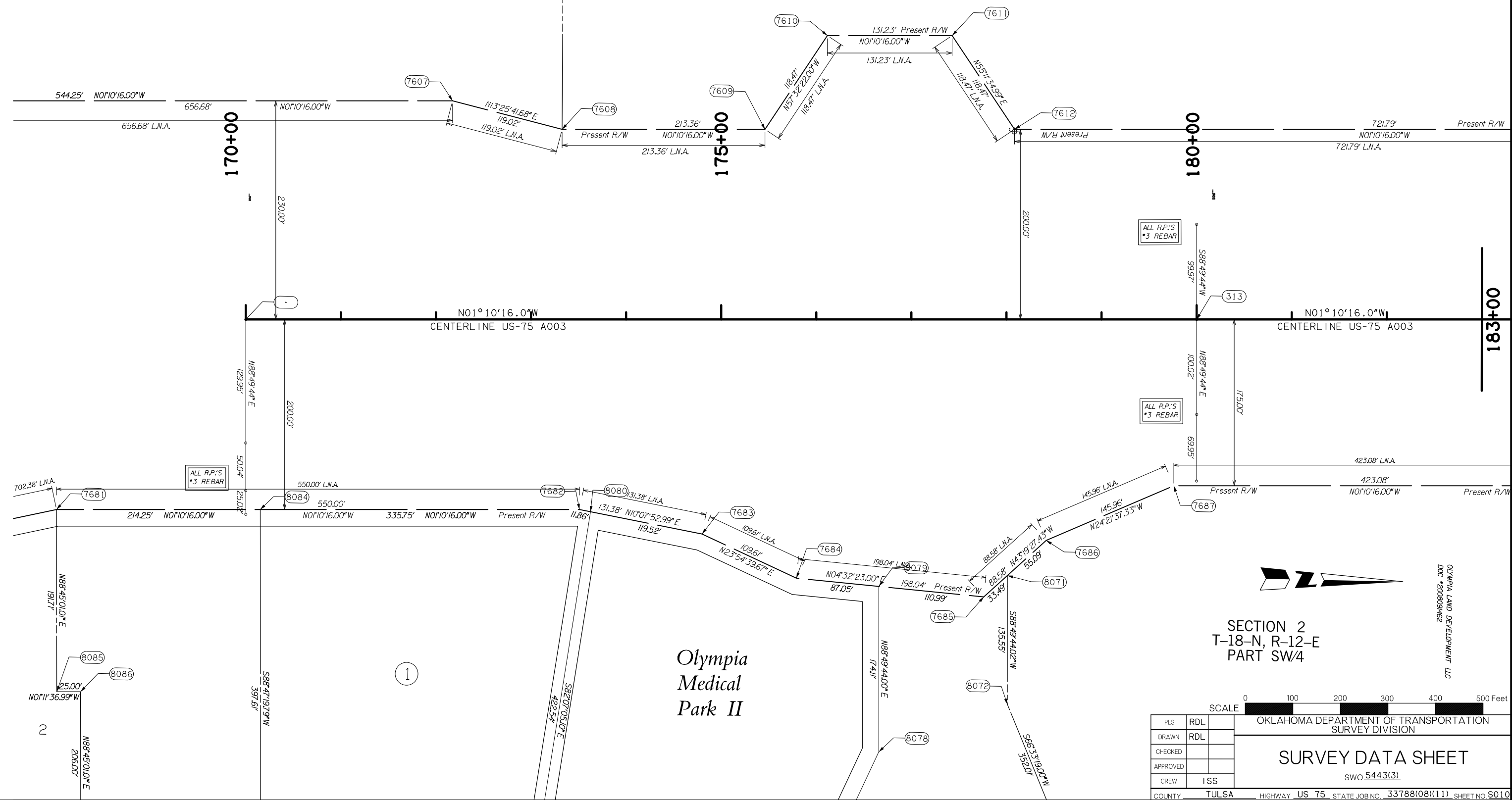

SECTION 2
T-18-N, R-12-E
PART SW/4

SCALE 0 100 200 300 400 500 Feet

PLS	RDL	
DRAWN	RDL	
CHECKED		
APPROVED		
CREW	ISS	

OKLAHOMA DEPARTMENT OF TRANSPORTATION
SURVEY DIVISION

SURVEY DATA SHEET
SWO 5443(3)

COUNTY TULSA HIGHWAY US 75 STATE JOB NO. 33788(08)(11) SHEET NO S010

OLYMPIA LAND DEVELOPMENT LLC
DOC # 2008091462

Olympia
Medical
Park II

1

2

SECTION 2
T-18-N, R-12-E
PART SW/4

SECTION 2
T-18-N, R-12-E
PART NW/4

MCGEHEE, LEONE C & 1ST NATL BK
& TR CO OK CITY TTEES ETAL
DOC #2004078867

ONEOK INC C/O KANSAS GAS SERVICE
BK 5878, PG 2255

SECTION 2
T-18-N, R-12-E
PART SW/4

OLYMPIA LAND DEVELOPMENT LLC
DOC #2008091462

MCGEHEE, LEONE C &
1ST NATL BK & TR CO
OK CITY TTEES ETAL
DOC #2004078867

SECTION 2
T-18-N, R-12-E
PART NW/4

SCALE 0 100 200 300 400 500 Feet

OKLAHOMA DEPARTMENT OF TRANSPORTATION
SURVEY DIVISION

SURVEY DATA SHEET

SWO 5443(3)

PLS	RDL	
DRAWN	RDL	
CHECKED		
APPROVED		
CREW	ISS	

COUNTY TULSA HIGHWAY US 75 STATE JOB NO. 33788(08)(11) SHEET NO S011

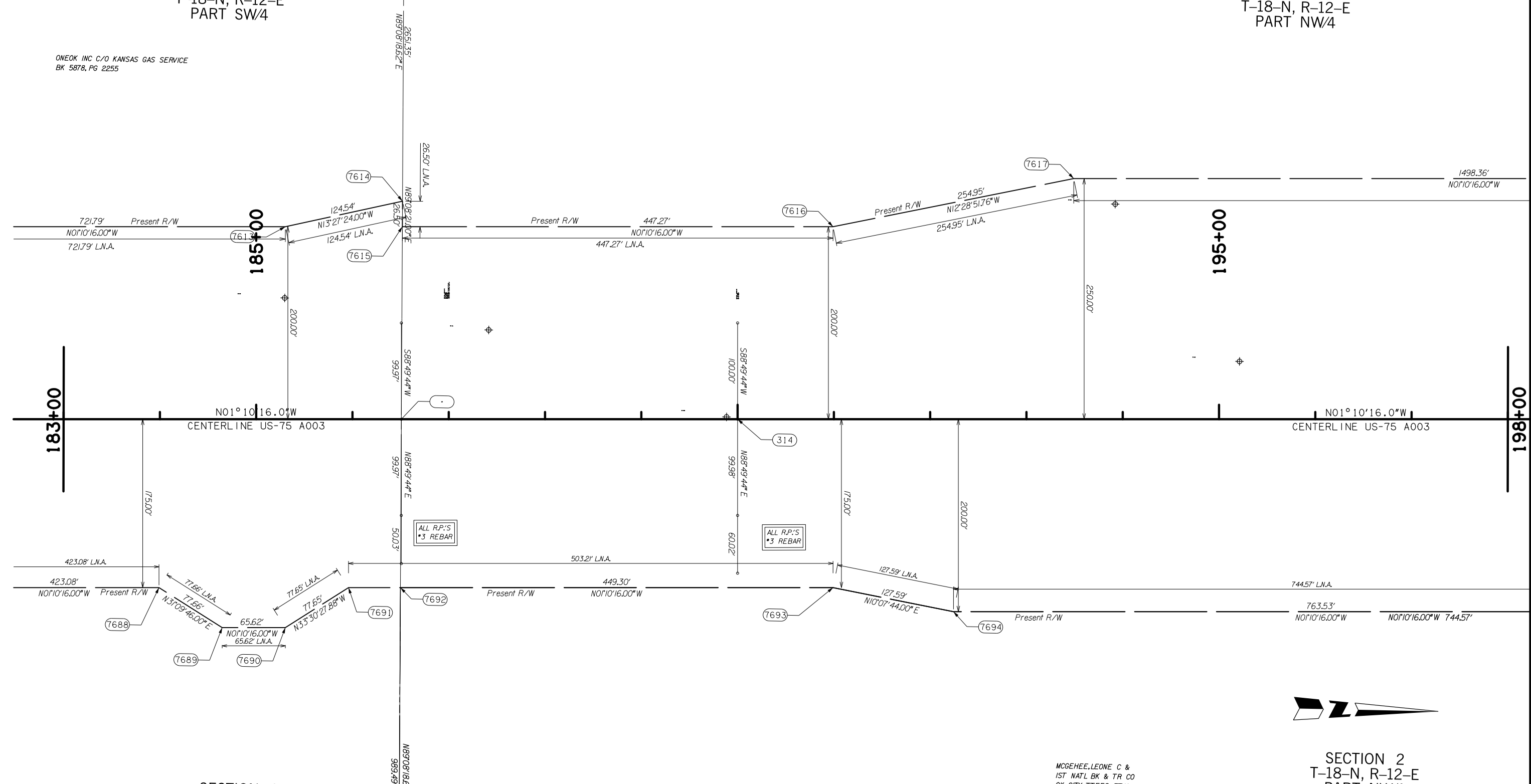

3/4/2021
F:\FDB\1650-TUL\CIV\400315_000T_EC2123A_US75_Design-Working\Civil\MicroStation\337888\165-Sheets\337888\165-Survey_12.dgn

SECTION 2
T-18-N, R-12-E
PART NW/4

SECTION 2
T-18-N, R-12-E
PART NW/4

OKLAHOMA DEPARTMENT OF TRANSPORTATION
R/W UTILITY MEETING
MARCH 2021

MCGEEHEE, LEONE C & 1ST NATL BK
& TR CO OK CITY TTEES ETAL
DOC #2004078867

SECTION 35
T-19-N, R-12-E
PART SW/4

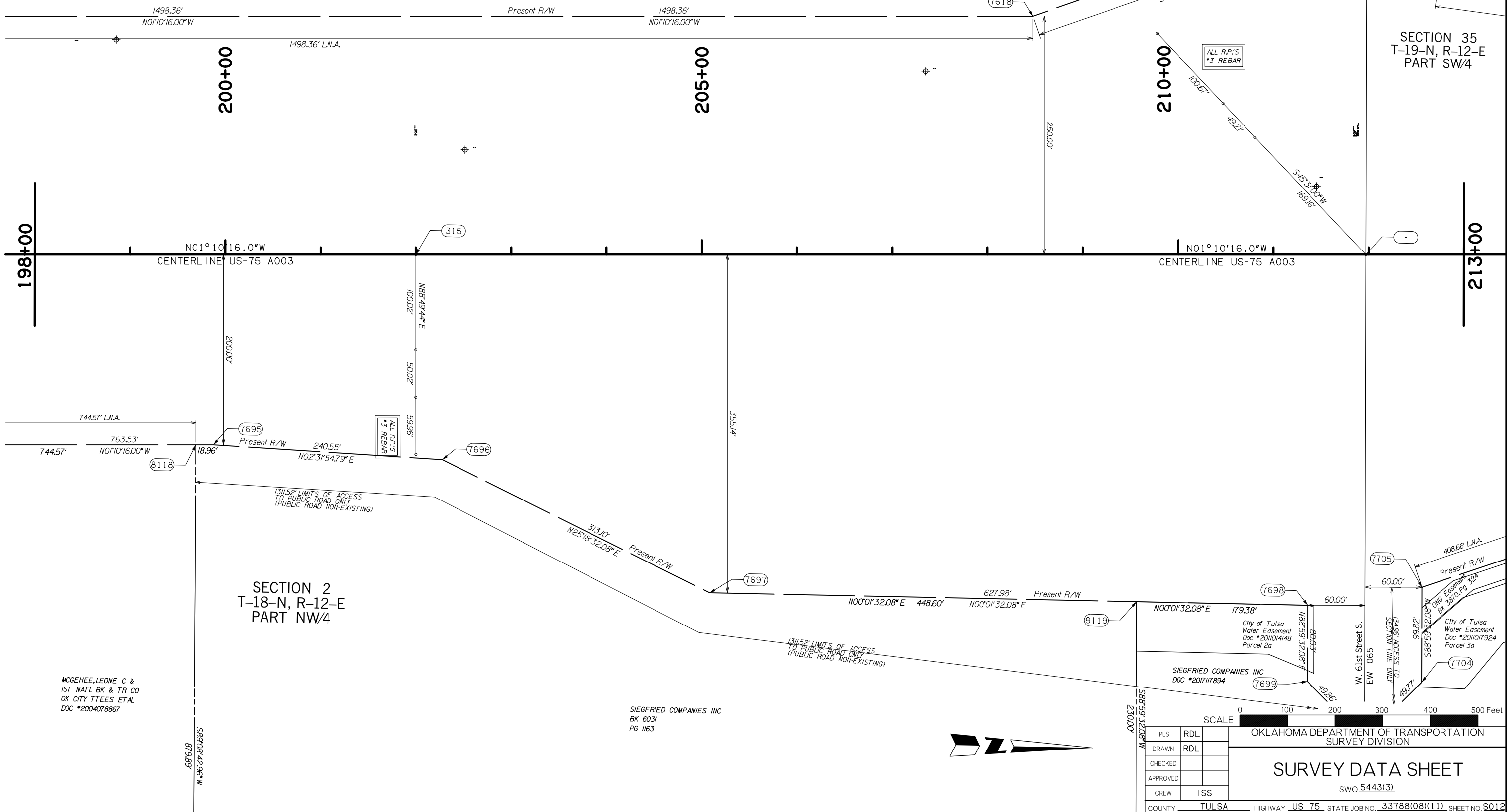

SCALE		0 100 200 300 400 500 Feet	
OKLAHOMA DEPARTMENT OF TRANSPORTATION SURVEY DIVISION			
SURVEY DATA SHEET			
SWO 5443(3)			
PLS	RDL		
DRAWN	RDL		
CHECKED			
APPROVED			
CREW	ISS		
COUNTY TULSA		HIGHWAY US 75 STATE JOB NO. 33788(08)(11) SHEET NO S012	

MCGEEHEE, LEONE C & 1ST NATL BK & TR CO
OK CITY TTEES ETAL
DOC #2004078867

SIEGFRIED COMPANIES INC
BK 6031
PG 1163

City of Tulsa
Water Easement
Doc #201017924
Parcel 3a

City of Tulsa
Water Easement
Doc #201014148
Parcel 2a

SIEGFRIED COMPANIES INC
DOC #201717894

3/4/2021
 P:\FDB\1650-TUL\CIV\40035_000T_EC2123A_US75\Design-Working\CIVL\MicroStation\337888\WP5\Sheets\337888-Survey_13.dgn

SECTION 35
 T-19-N, R-12-E
 PART SW/4

SECTION 35
 T-19-N, R-12-E
 PART SW/4

CITY OF TULSA
 BK 2395, PG 216

Parkview
 Terrace

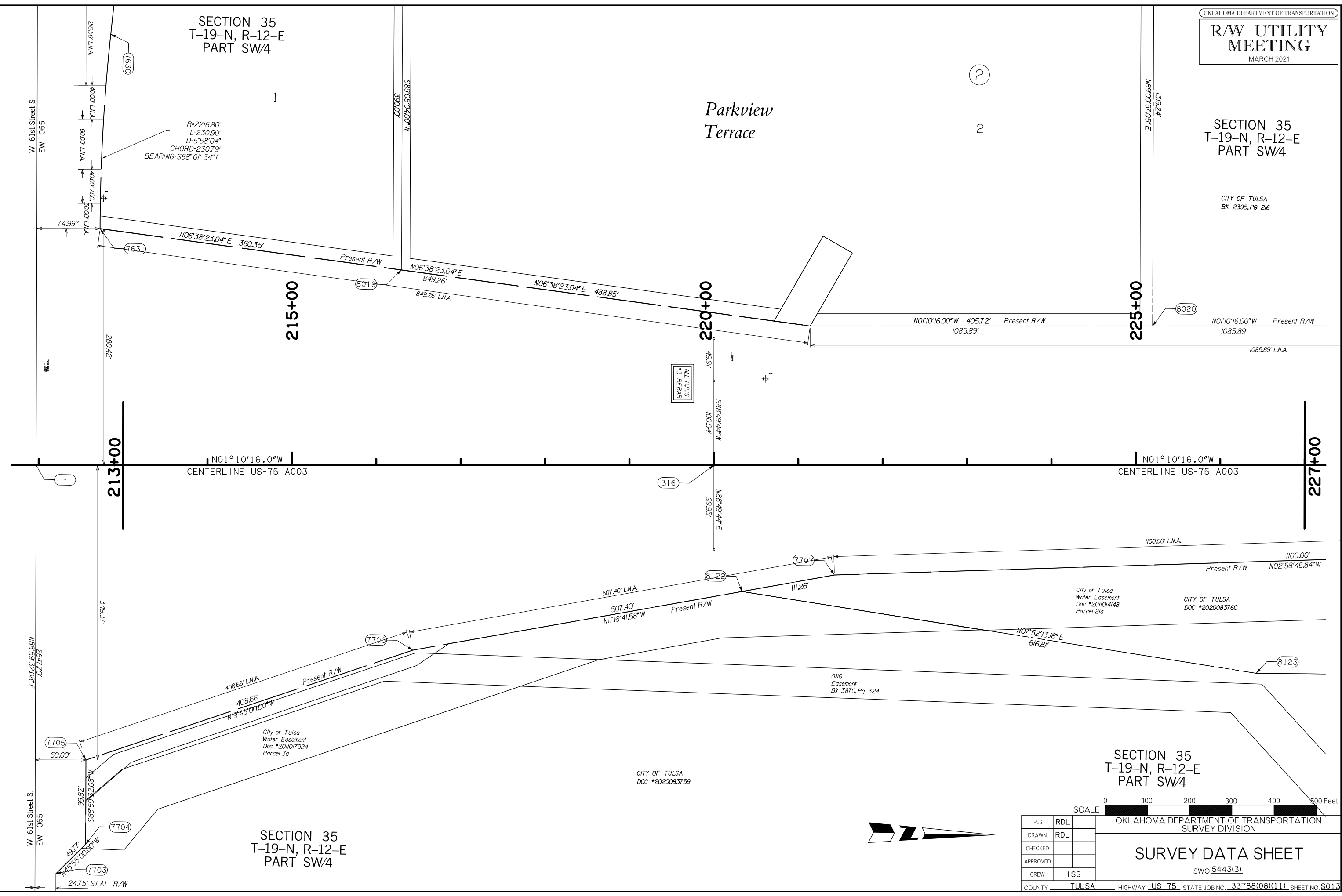

N01°10'16.0"W
 CENTERLINE US-75 A003

N01°10'16.0"W
 CENTERLINE US-75 A003

SECTION 35
 T-19-N, R-12-E
 PART SW/4

SECTION 35
 T-19-N, R-12-E
 PART SW/4

CITY OF TULSA
 DOC #2020083759

SCALE 0 100 200 300 400 500 Feet

PLS	RDL	
DRAWN	RDL	
CHECKED		
APPROVED		
CREW	ISS	

OKLAHOMA DEPARTMENT OF TRANSPORTATION
 SURVEY DIVISION

SURVEY DATA SHEET

SWO 5443(3)

COUNTY TULSA HIGHWAY US 75 STATE JOB NO. 33788(08)(11) SHEET NO S013

3/4/2021
F:\FDB\1650-TUL\CIV\40035_000T_EC2\23A_US75\Design-Working\CIVL\MicroStation\337888\WP5\Sheets\337888-Survey-14.dgn

R/W UTILITY MEETING
SECTION 35
T-19-N, R-12-E
PART NW/4
MARCH 2021

The Prairie Pipe Line Co.
Blanket R.O.W. Easement
SNW/4 of NW/4
Book 799 Page 343
Assigned to OGC Pipeline, L.L.C.
Book 6299 Page 2116

SECTION 35
T-19-N, R-12-E
PART SW/4

The Prairie Pipe Line Co.
Blanket R.O.W. Easement
NW/4 of SW/4
Book 799 Page 343
Assigned to OGC Pipeline, L.L.C.
Book 6299 Page 2116

CITY OF TULSA
BK 2395, PG 216

City of Tulsa
Deed Book 2395 Page 216

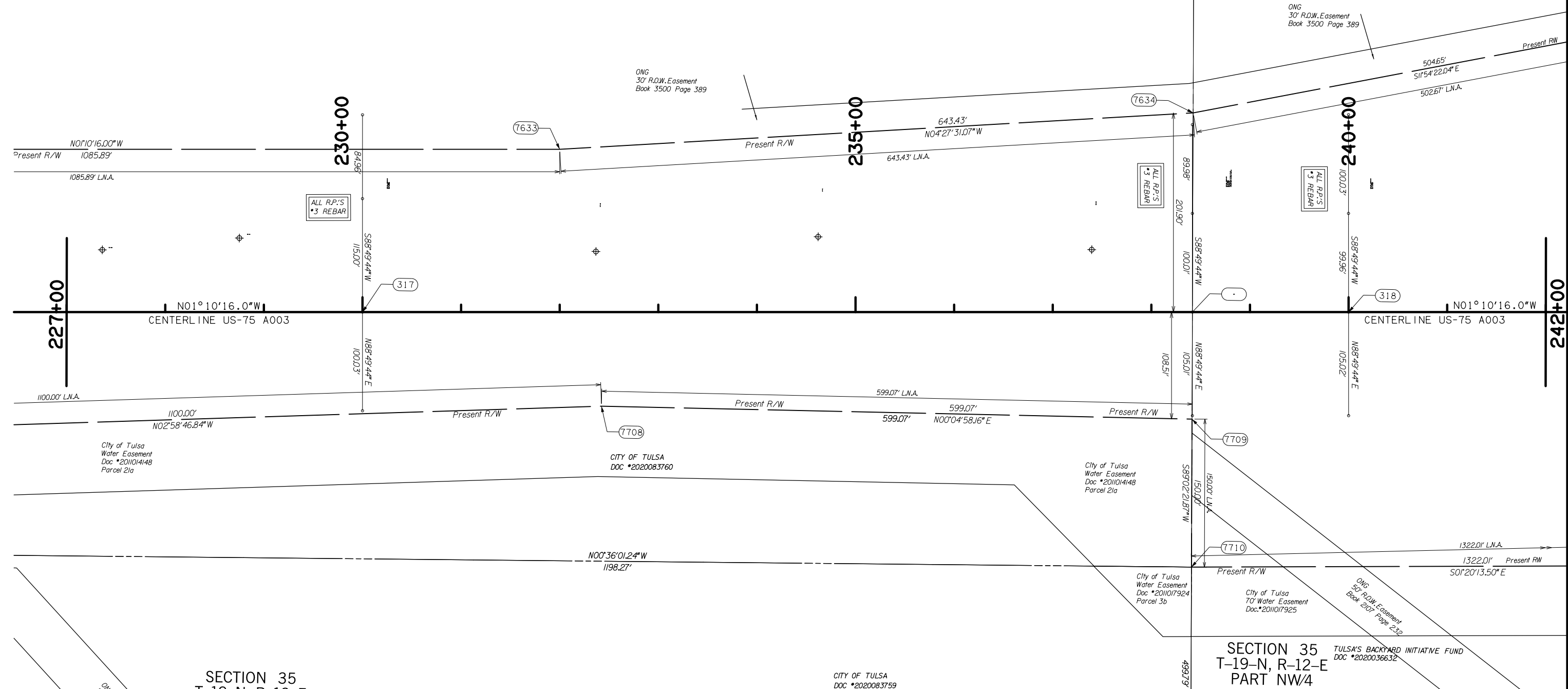

227+00

230+00

235+00

240+00

242+00

CENTERLINE US-75 A003

CENTERLINE US-75 A003

SECTION 35
T-19-N, R-12-E
PART SW/4

SECTION 35
T-19-N, R-12-E
PART NW/4

TULSA'S BACKYARD INITIATIVE FUND
DOC #2020036632

CITY OF TULSA
DOC #2020083759

SCALE 0 100 200 300 400 500 Feet



PLS	RDL
DRAWN	RDL
CHECKED	
APPROVED	
CREW	ISS

OKLAHOMA DEPARTMENT OF TRANSPORTATION
SURVEY DIVISION

SURVEY DATA SHEET

SWO 5443(3)

SECTION 35
T-19-N, R-12-E
PART NW/4

The Prairie Pipe Line Co.
Blanket R.O.W. Easement
SNW/4 of NW/4
Book 799 Page 343
Assigned to OGC Pipeline, L.L.C.
Book 6299 Page 2116

City of Tulsa
Deed Book 2395 Page 216

SECTION 35
T-19-N, R-12-E
PART NW/4

Johnson, Willis G. & Evelyn M.
Warranty Deed
Doc. #2007024592

OKLAHOMA DEPARTMENT OF TRANSPORTATION
R/W UTILITY MEETING
MARCH 2021

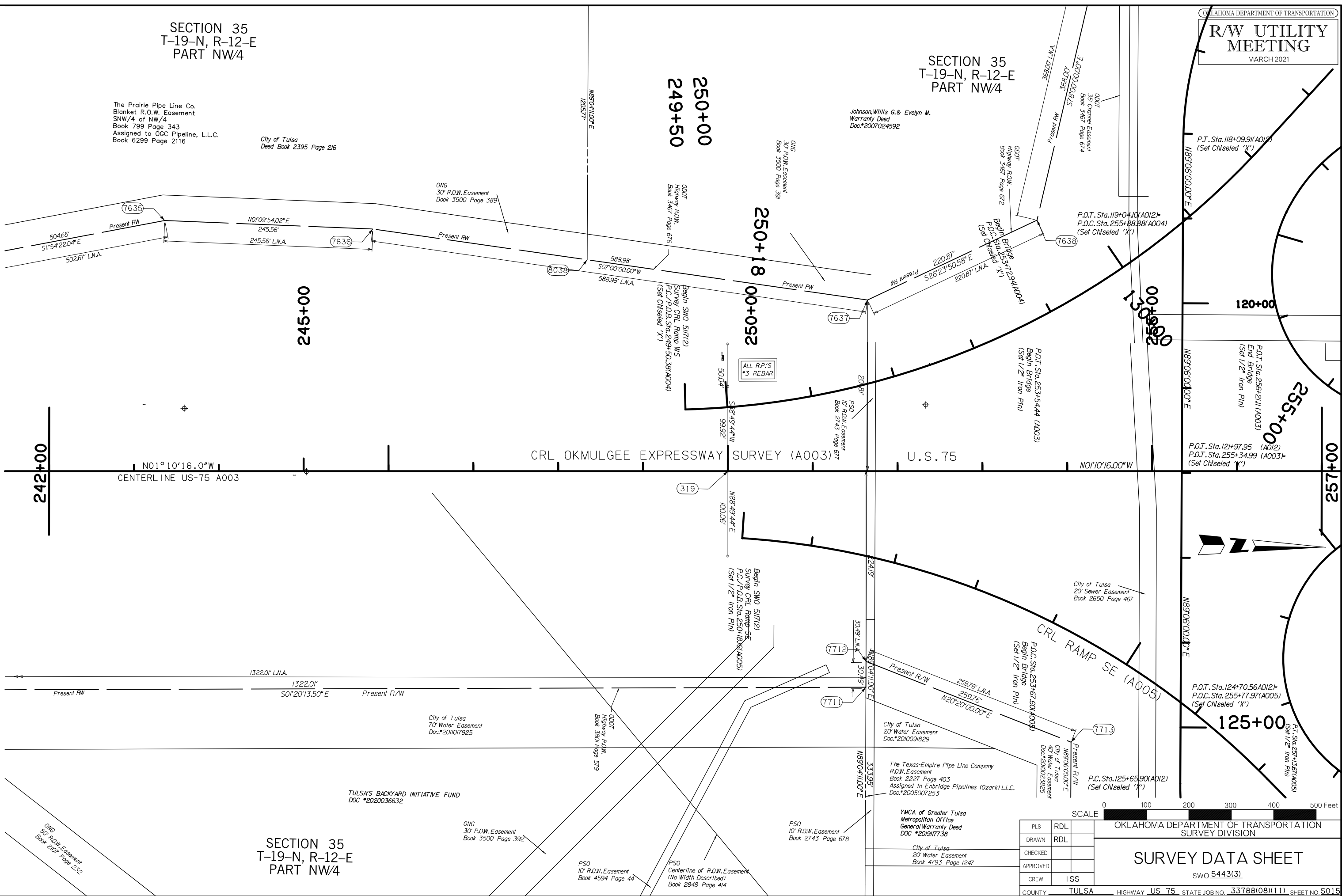

242+00

245+00

250+00
249+50

250+18
00+052

00+992
150+992

120+00

255+00

257+00

CENTERLINE US-75 A003

CRL OKMULGEE EXPRESSWAY SURVEY (A003)

U.S. 75

CRL RAMP SE (A005)

SECTION 35
T-19-N, R-12-E
PART NW/4

OKLAHOMA DEPARTMENT OF TRANSPORTATION
SURVEY DIVISION

SURVEY DATA SHEET

SWO 5443(3)

PLS	RDL
DRAWN	RDL
CHECKED	
APPROVED	
CREW	ISS

COUNTY TULSA HIGHWAY US 75 STATE JOB NO. 33788(08)(11) SHEET NO S015

TULSA'S BACKYARD INITIATIVE FUND
DOC #2020036632

The Texas-Empire Pipe Line Company
R.O.W. Easement
Book 2227 Page 403
Assigned to Enbridge Pipelines (Ozark) L.L.C.
Doc. #2005007253

City of Tulsa
20' Water Easement
Book 4793 Page 1247

YMCA of Greater Tulsa
Metropolitan Office
General Warranty Deed
DOC #201917738

PSO
10' R.O.W. Easement
Book 4594 Page 44

PSO
Centerline of R.O.W. Easement
(No Width Described)
Book 2848 Page 414

ONG
30' R.O.W. Easement
Book 3500 Page 392

ONG
30' R.O.W. Easement
Book 3801 Page 579

PSO
10' R.O.W. Easement
Book 2743 Page 678

City of Tulsa
40' Water Easement
Doc. #2010023825

City of Tulsa
20' Sewer Easement
Book 2650 Page 467

City of Tulsa
70' Water Easement
Doc. #201001925

ONG
30' R.O.W. Easement
Book 3500 Page 389

ONG
Highway R.O.W.
Book 3467 Page 676

ONG
30' R.O.W. Easement
Book 3500 Page 391

ONG
Highway R.O.W.
Book 3467 Page 672

ONG
35' Channel Easement
Book 3467 Page 674

P.O.T. Sta. 253+54.44 (A003)
Begin Bridge
(Set 1/2" Iron Pin)

P.O.T. Sta. 256+21.11 (A003)
End Bridge
(Set 1/2" Iron Pin)

P.O.T. Sta. 124+70.56 (A012)
P.O.C. Sta. 255+77.97 (A005)
(Set Chiseled 'X')

P.O.T. Sta. 125+65.90 (A012)
(Set Chiseled 'X')

P.O.T. Sta. 119+04.10 (A012)
P.O.C. Sta. 255+88.88 (A004)
(Set Chiseled 'X')

P.T. Sta. 118+09.91 (A012)
(Set Chiseled 'X')

Begin SMO 517(2)
Survey CRL Ramp SE
P.C./P.O.B. Sta. 249+50.38 (A004)
(Set Chiseled 'X')

Begin SMO 517(2)
Survey CRL Ramp SE
P.C./P.O.B. Sta. 250+18.61 (A005)
(Set 1/2" Iron Pin)

ALL R.P.'S
#3 REBAR

PSO
10' R.O.W. Easement
Book 2743 Page 677

PSO
10' R.O.W. Easement
Book 2743 Page 678

P.O.C. Sta. 253+67.60 (A008)
Begin Bridge
(Set 1/2" Iron Pin)

P.T. Sta. 257+13.61 (A005)
(Set 1/2" Iron Pin)

PSO
10' R.O.W. Easement
Book 2743 Page 677

PSO
10' R.O.W. Easement
Book 2743 Page 677

PSO
10' R.O.W. Easement
Book 2743 Page 677

PSO
10' R.O.W. Easement
Book 2743 Page 677

PSO
10' R.O.W. Easement
Book 2743 Page 677

PSO
10' R.O.W. Easement
Book 2743 Page 677

PSO
10' R.O.W. Easement
Book 2743 Page 677

PSO
10' R.O.W. Easement
Book 2743 Page 677

PSO
10' R.O.W. Easement
Book 2743 Page 677

PSO
10' R.O.W. Easement
Book 2743 Page 677

PSO
10' R.O.W. Easement
Book 2743 Page 677

PSO
10' R.O.W. Easement
Book 2743 Page 677

PSO
10' R.O.W. Easement
Book 2743 Page 677

PSO
10' R.O.W. Easement
Book 2743 Page 677

PSO
10' R.O.W. Easement
Book 2743 Page 677

PSO
10' R.O.W. Easement
Book 2743 Page 677

PSO
10' R.O.W. Easement
Book 2743 Page 677

PSO
10' R.O.W. Easement
Book 2743 Page 677

PSO
10' R.O.W. Easement
Book 2743 Page 677

PSO
10' R.O.W. Easement
Book 2743 Page 677

3/4/2022
 P:\FDB\1650-TUL CIV\40035_000T_EC2123A_US755_Design-Working\CIVL\MicroStation\337888\WP5\Sheets\337888I-Survey_16.dgn

Suburban Highlands
 2
 6

Crossroads Pentecostal Church of God Inc. Quit Claim Deed Book 4587 Page 1270
 ODOT Highway R.O.W. Book 3459 Page 191
 ODOT Highway R.O.W. Book 3459 Page 23

ODOT Highway R.O.W. Book 3459 Page 287
 Tulsa County, 10' R.O.W. Lot 3, Block 6 Book 1045 Page 287
 Tulsa County, 10' R.O.W. Lot 4, Block 6 Book 1045 Page 287

ODOT Highway R.O.W. Book 3459 Page 191
 ODOT Highway R.O.W. Book 3459 Page 23
 ODOT Highway R.O.W. Book 3459 Page 287

ODOT Highway R.O.W. Book 3459 Page 191
 ODOT Highway R.O.W. Book 3459 Page 23
 ODOT Highway R.O.W. Book 3459 Page 287

ODOT Highway R.O.W. Book 3459 Page 191
 ODOT Highway R.O.W. Book 3459 Page 23
 ODOT Highway R.O.W. Book 3459 Page 287

ODOT Highway R.O.W. Book 3459 Page 191
 ODOT Highway R.O.W. Book 3459 Page 23
 ODOT Highway R.O.W. Book 3459 Page 287

ODOT Highway R.O.W. Book 3459 Page 191
 ODOT Highway R.O.W. Book 3459 Page 23
 ODOT Highway R.O.W. Book 3459 Page 287

ODOT Highway R.O.W. Book 3459 Page 191
 ODOT Highway R.O.W. Book 3459 Page 23
 ODOT Highway R.O.W. Book 3459 Page 287

ODOT Highway R.O.W. Book 3459 Page 191
 ODOT Highway R.O.W. Book 3459 Page 23
 ODOT Highway R.O.W. Book 3459 Page 287

ODOT Highway R.O.W. Book 3459 Page 191
 ODOT Highway R.O.W. Book 3459 Page 23
 ODOT Highway R.O.W. Book 3459 Page 287

ODOT Highway R.O.W. Book 3459 Page 191
 ODOT Highway R.O.W. Book 3459 Page 23
 ODOT Highway R.O.W. Book 3459 Page 287

ODOT Highway R.O.W. Book 3459 Page 191
 ODOT Highway R.O.W. Book 3459 Page 23
 ODOT Highway R.O.W. Book 3459 Page 287

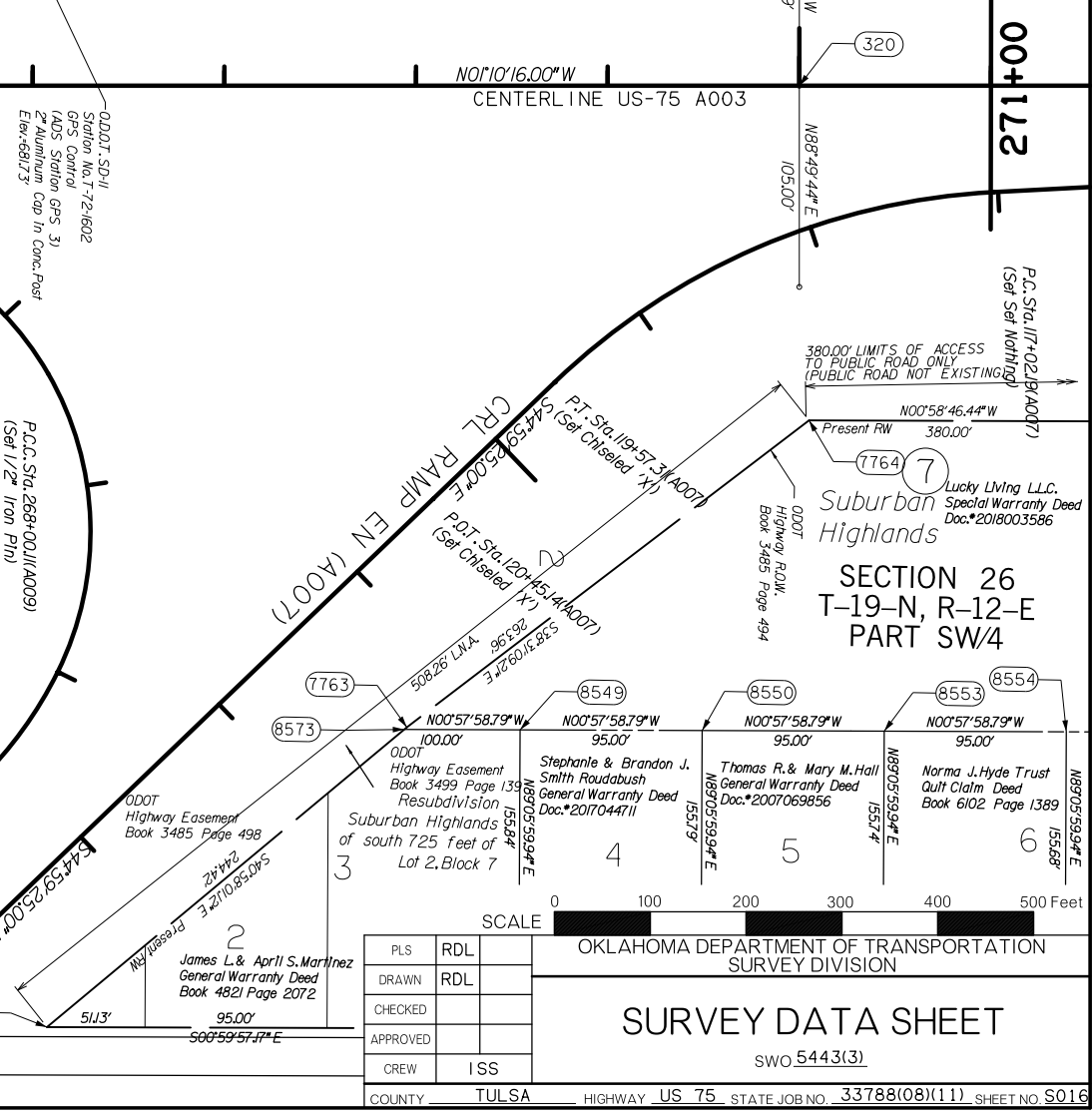
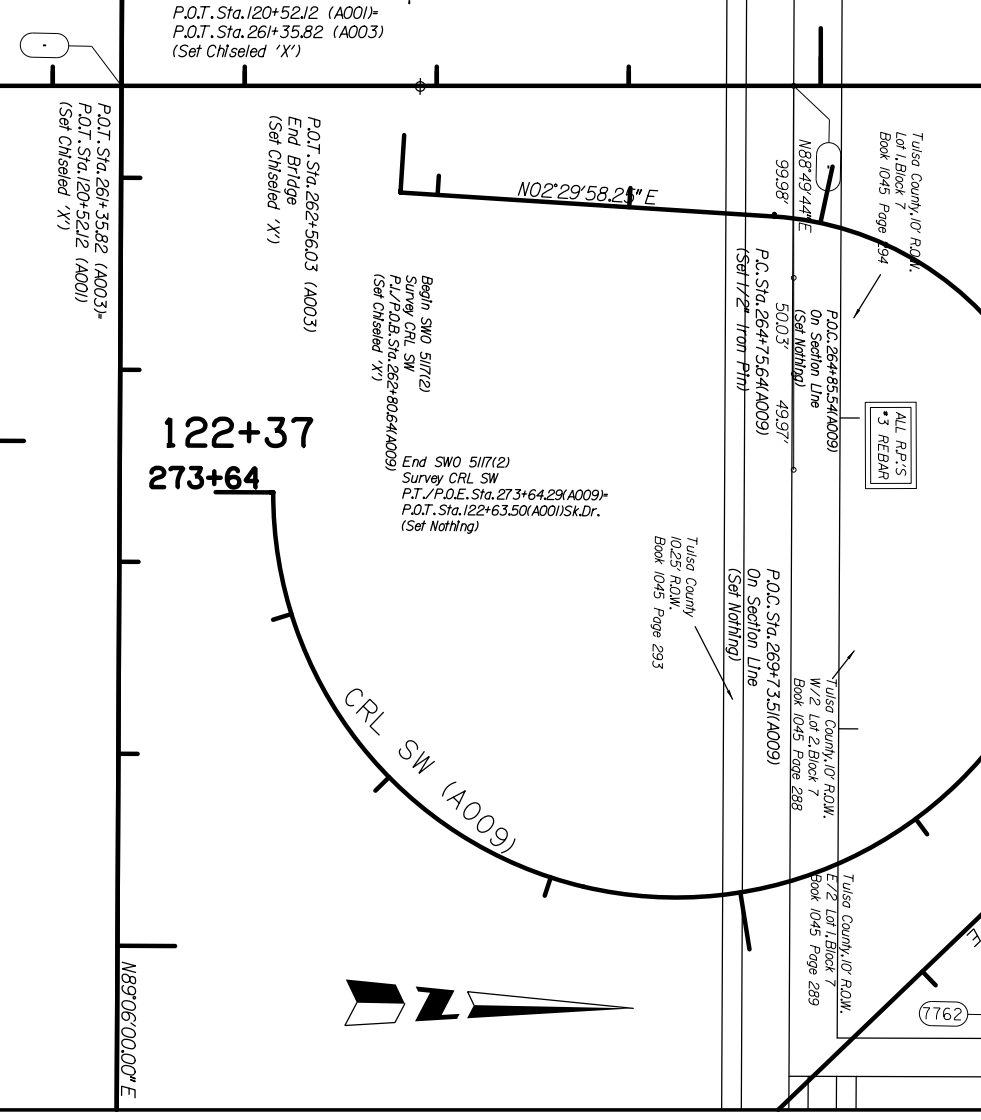
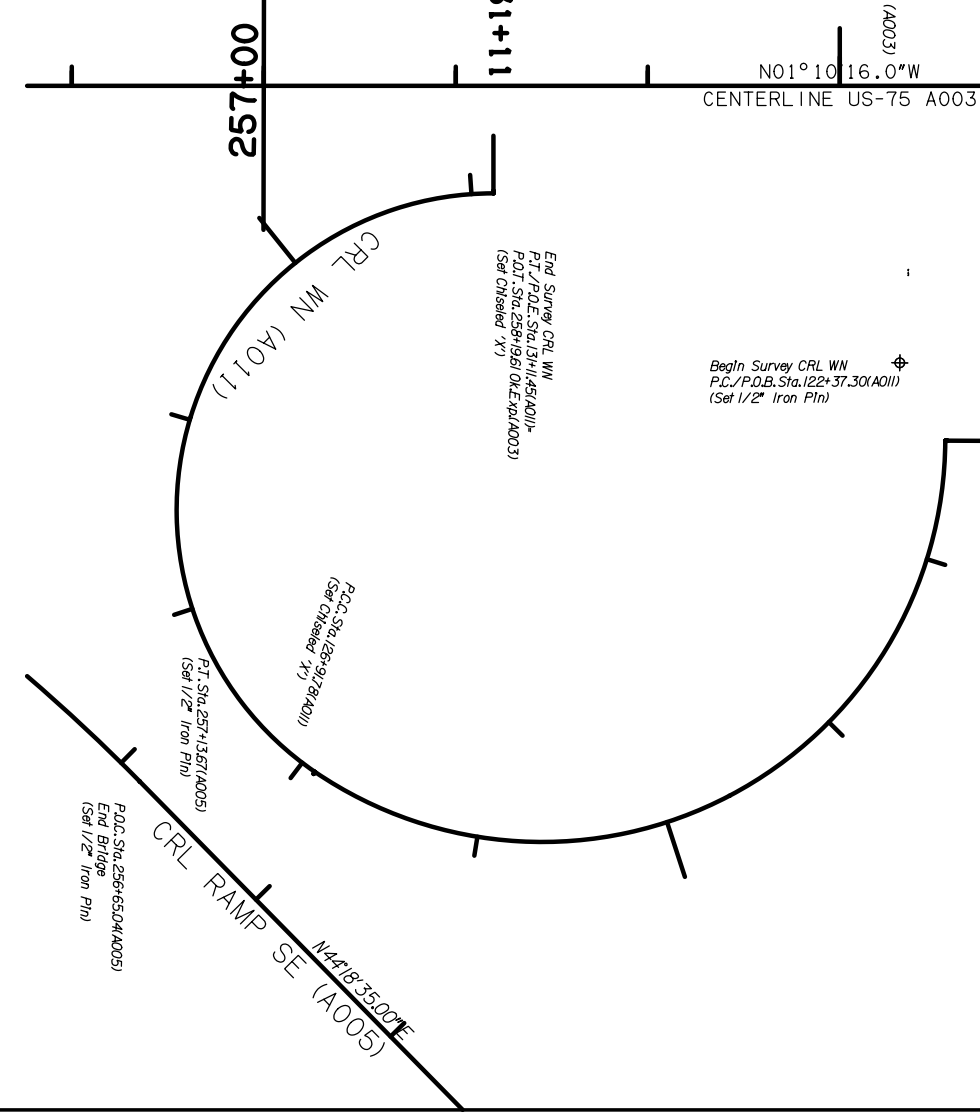
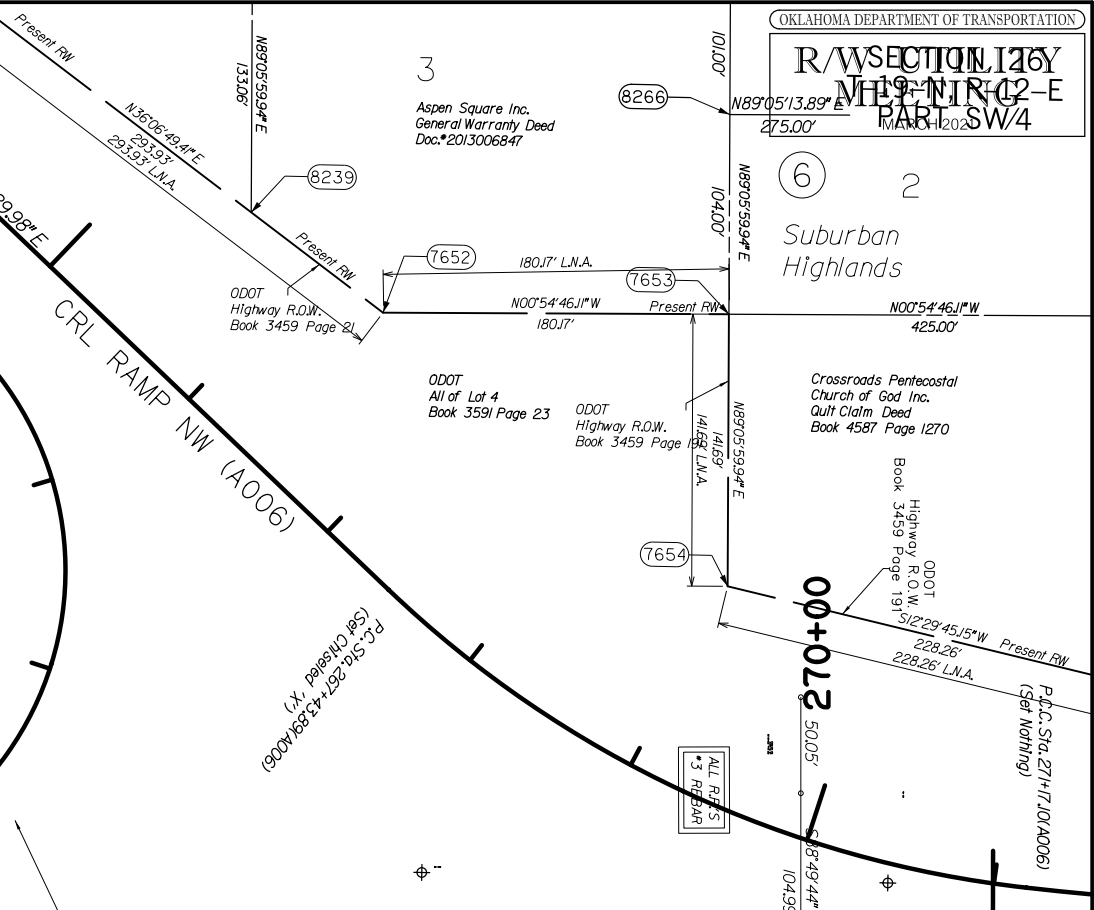
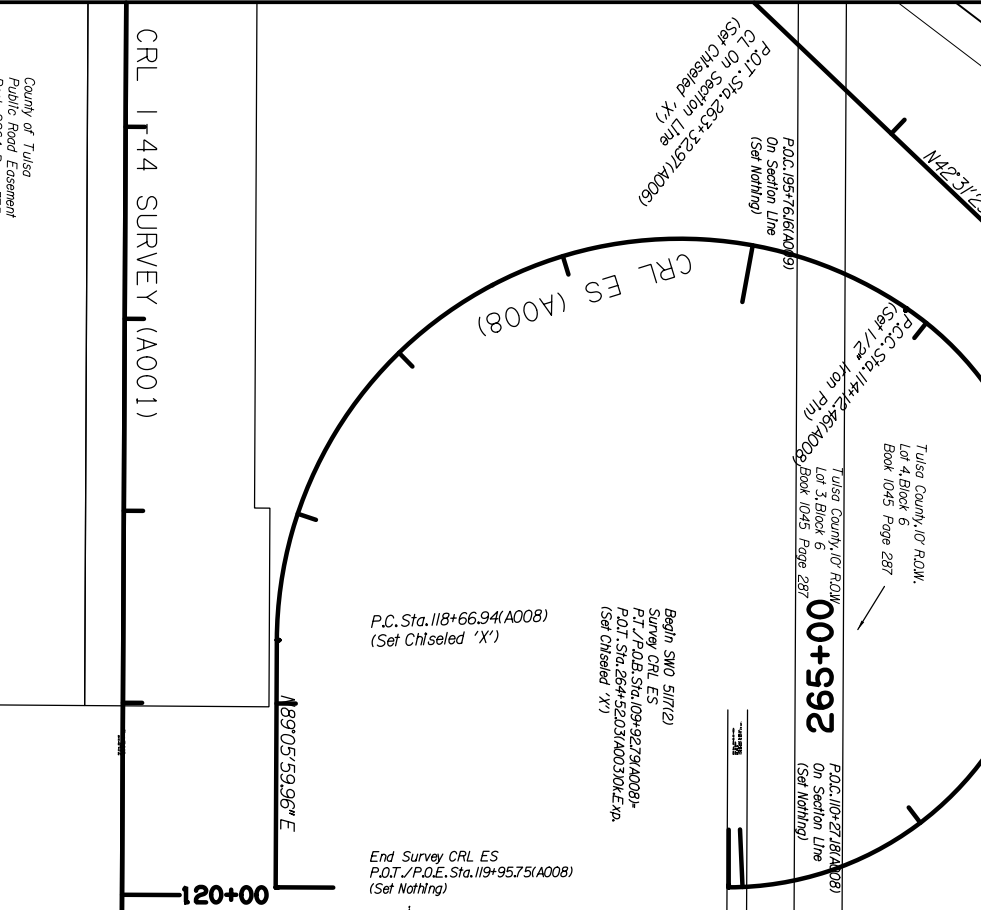
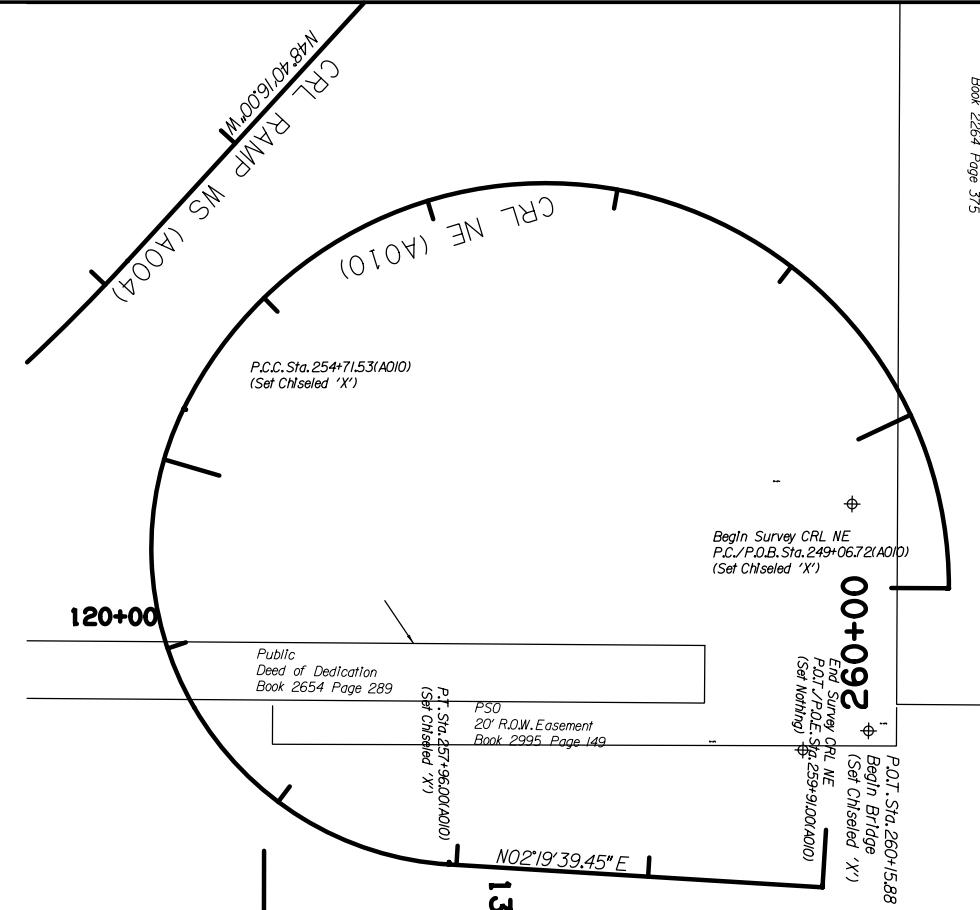

SCALE 0 100 200 300 400 500 Feet

OKLAHOMA DEPARTMENT OF TRANSPORTATION
 SURVEY DIVISION

SURVEY DATA SHEET
 SWO 5443(3)

PLS	RDL
DRAWN	RDL
CHECKED	
APPROVED	
CREW	ISS

COUNTY TULSA HIGHWAY US 75 STATE JOB NO. 33788(08)(11) SHEET NO S016

James L & April S. Martinez
 General Warranty Deed
 Book 4821 Page 2072

Stephanie & Brandon J. Smith Roudabush
 General Warranty Deed
 Doc. #2017044711

Thomas R. & Mary M. Hall
 General Warranty Deed
 Doc. #2007069856

Norma J. Hyde Trust
 Quit Claim Deed
 Book 6102 Page 1389

Lucky Living LLC.
 Special Warranty Deed
 Doc. #2018003586

SECTION 26
 T-19-N, R-12-E
 PART SW/4

3/4/2022
P:\FDB\1650-TUL CIV\1400315-0001_EC2123A-US75-Design-Working\CIVL\MicroStation\3378811-Survey-IT.dgn

OKLAHOMA DEPARTMENT OF TRANSPORTATION
RW UTILITY
MARCH 2021

SECTION 26
T-19-N, R-12-E
PART SW/4

SECTION 26
T-19-N, R-12-E
PART SW/4

6

Suburban
Highlands

Suburban
Highlands

1

SECTION 26
T-19-N, R-12-E
PART SW/4

SECTION 26
T-19-N, R-12-E
PART SW/4

6

Suburban
Highlands

CASEY, RHONDA L TRUST
DOC 2017068642

SECTION 26
T-19-N, R-12-E
PART SW/4

6

Resubdivision
of south 725 feet of
Lot 2, Block 7

Norma J. Hyde Trust
Quit Claim Deed
Book 6102 Page 1389

C. Phillip & Janice
Morris Living Trust
Quit Claim Deed
Doc. #2008070577

Jennifer Delozier
Quit Claim Deed
Doc. #2012056763

Private
10' Water Easement
Book 4507 Page 1019
Book 4515 Page 177
Book 4644 Page 277
Book 4507 Page 1019

Private
10' Water Easement
Book 4495 Page 1133
Book 4507 Page 1020
Book 4515 Page 178
Book 4507 Page 1020

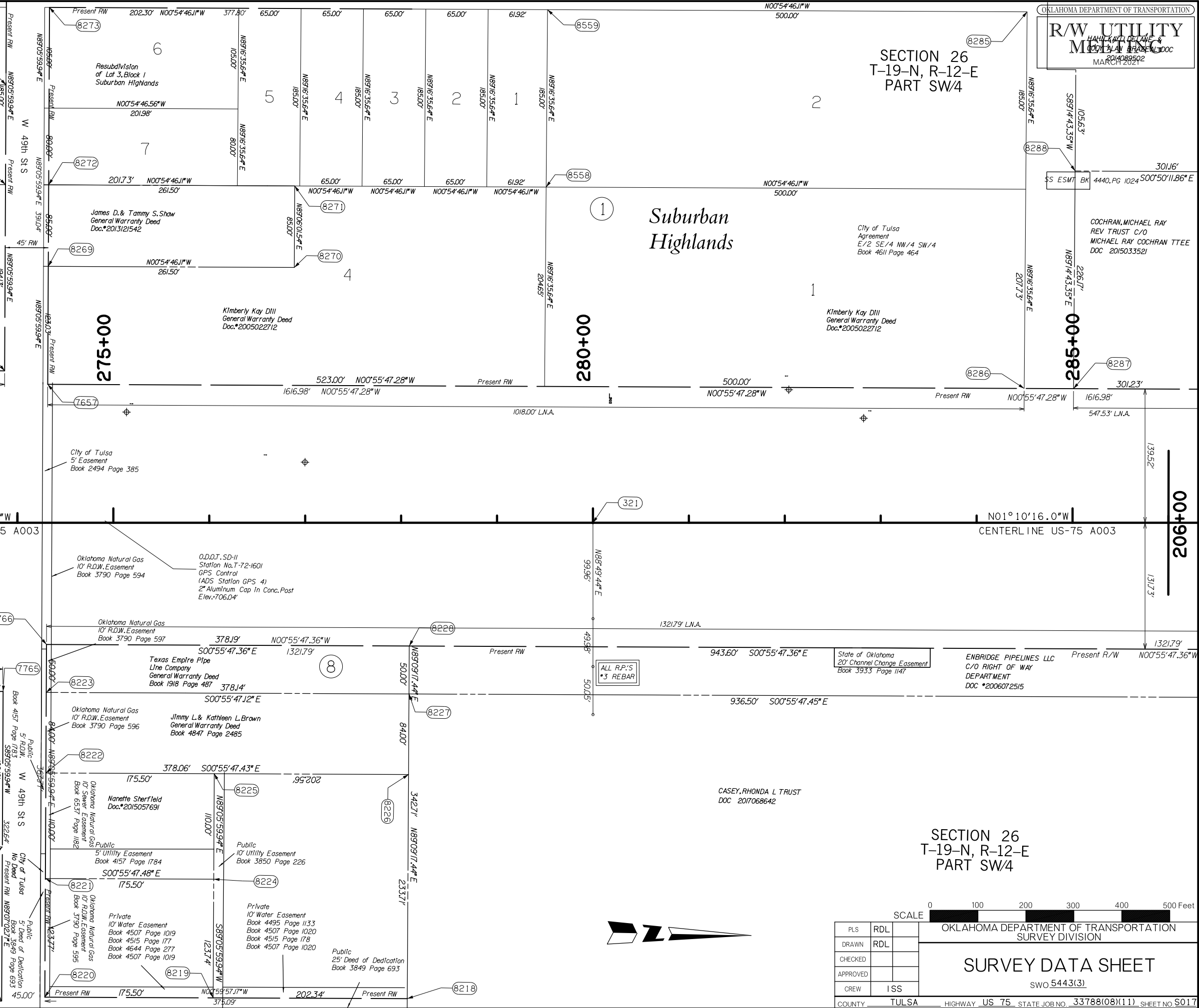

SCALE 0 100 200 300 400 500 Feet

PLS	RDL
DRAWN	RDL
CHECKED	
APPROVED	
CREW	ISS

OKLAHOMA DEPARTMENT OF TRANSPORTATION
SURVEY DIVISION

SURVEY DATA SHEET
SWO 5443(3)

COUNTY TULSA HIGHWAY US 75 STATE JOB NO. 33788(08)(11) SHEET NO S017

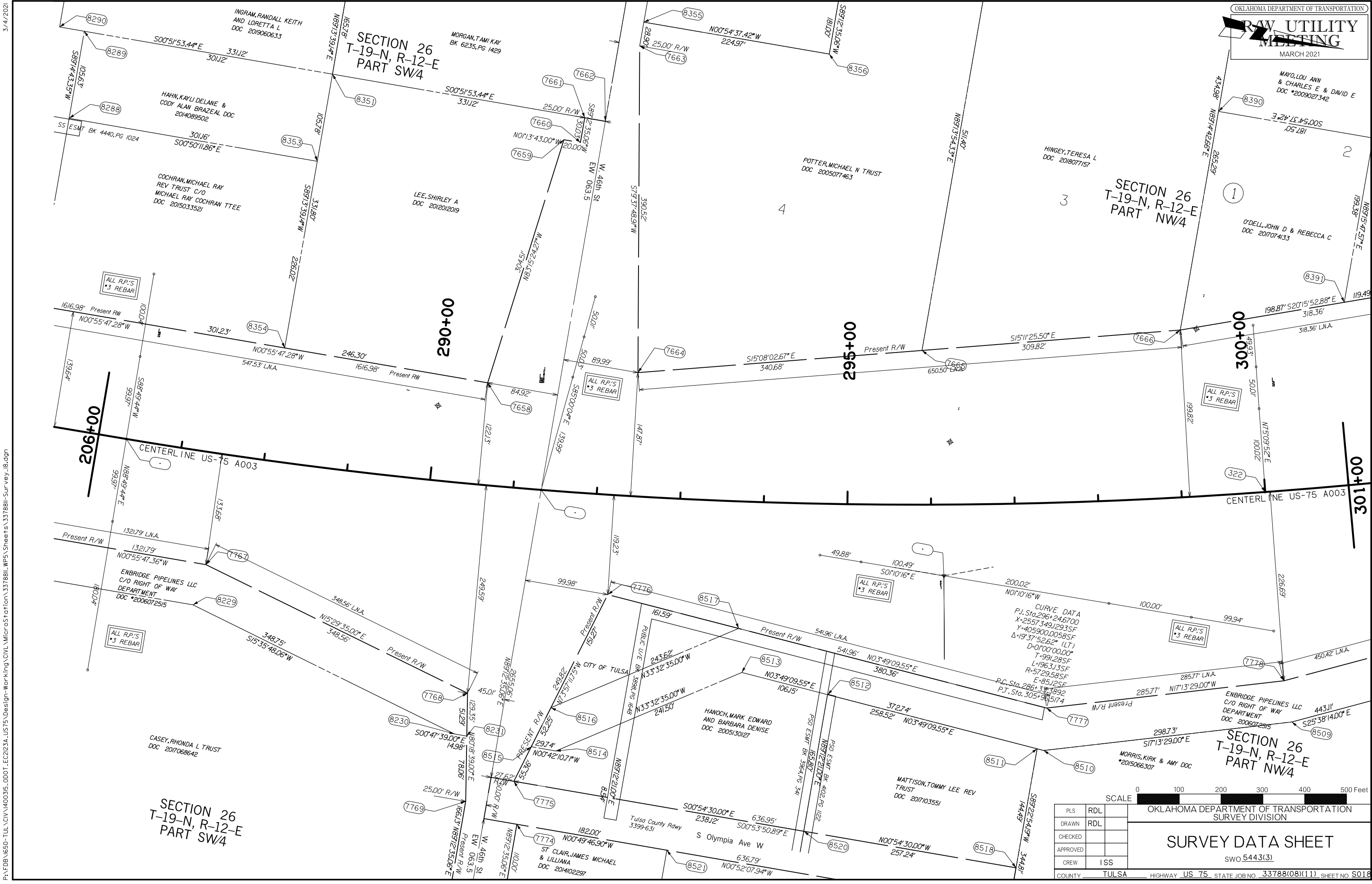

SECTION 26
 T-19-N, R-12-E
 PART SW/4

SCALE 0 100 200 300 400 500 Feet
 OKLAHOMA DEPARTMENT OF TRANSPORTATION
 SURVEY DIVISION

PLS	RDL
DRAWN	RDL
CHECKED	
APPROVED	
CREW	ISS

SURVEY DATA SHEET

SWO 5443(3)

3/4/2021
 P:\FDB\1650-TUL CIV\1400315_000T_EC2123A_US75.Design-Work\ing\CIVL\MicroStation\33788(11)\Survey-Sheet\33788(11)-Survey-18.dgn

3/4/2022
P:\FDB\1650-TUL CIV\400315-000T-EC2123A-US75-Design-Work\ing\CIVIL\MicroStation\3378881-WP5\Sheets\3378881-Survey-19.dgn

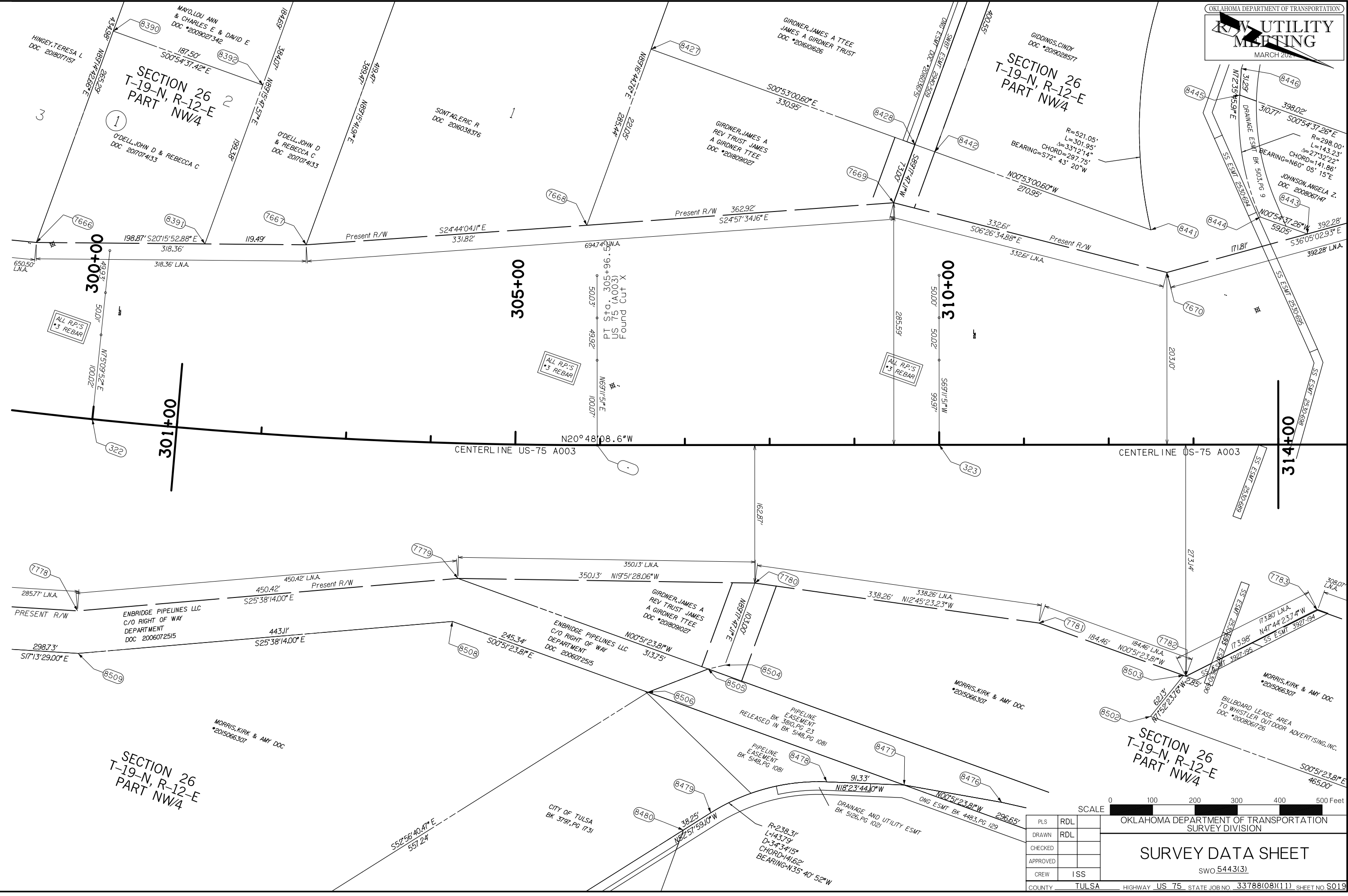

SCALE 0 100 200 300 400 500 Feet

OKLAHOMA DEPARTMENT OF TRANSPORTATION
SURVEY DIVISION

SURVEY DATA SHEET
SWO 5443(3)

PLS	RDL	
DRAWN	RDL	
CHECKED		
APPROVED		
CREW	ISS	
COUNTY	TULSA	HIGHWAY US 75 STATE JOB NO. 33788(08)(11) SHEET NO S019

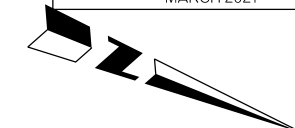

3/14/2021
F:\FDB\1650-TUL\CIV\400315_000T_EC2123A_US75\Design-Work\King\CIVL\MicroStation\337888\WP5\Sheets\337888\1-Sur-vey_20.dgn

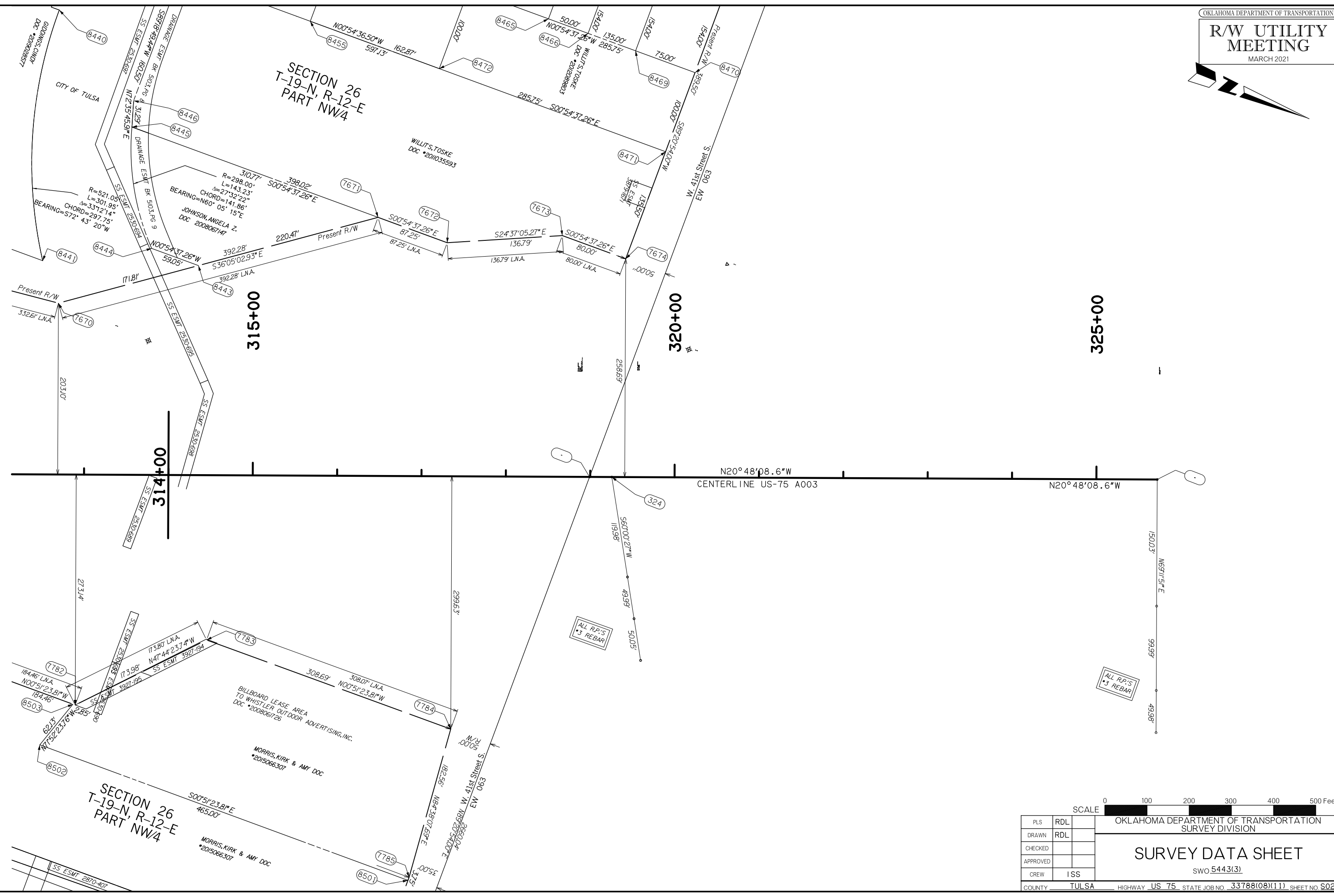

SCALE 0 100 200 300 400 500 Feet

PLS	RDL
DRAWN	RDL
CHECKED	
APPROVED	
CREW	ISS

OKLAHOMA DEPARTMENT OF TRANSPORTATION
SURVEY DIVISION

SURVEY DATA SHEET

SWO 5443(3)

COUNTY TULSA HIGHWAY US 75 STATE JOB NO. 33788(08)(11) SHEET NO S020

R/W UTILITY MEETING

MARCH 2021

3/4/2021

F:\FDB\1650-TUL\CIV\1400315_000T_EC2123A_US755_Design-Work\Inq\Civil\MicroStation\3378811_WP5_Sheets\3378811-Survey_21.dgn

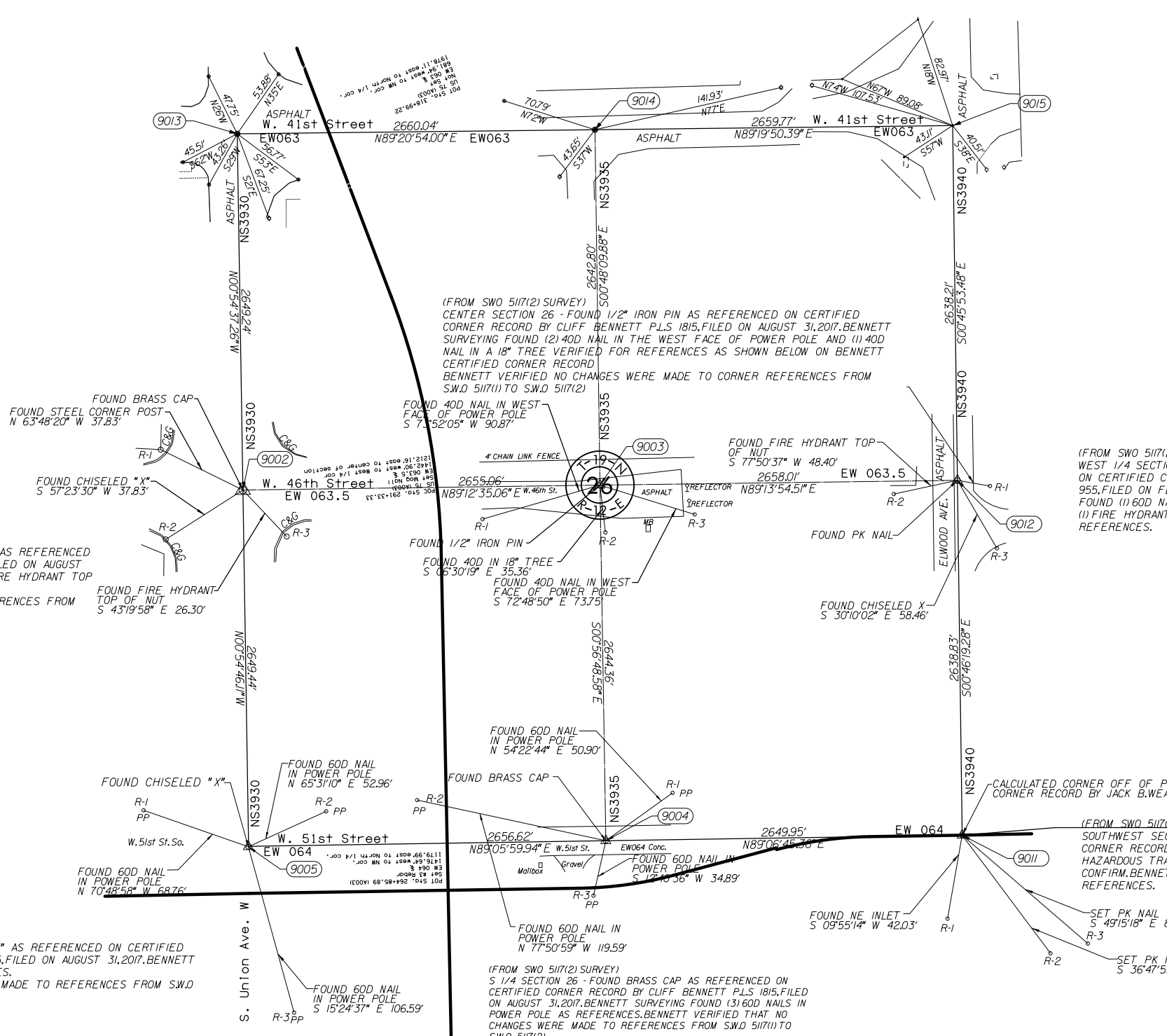

(FROM SWO 5117(2) SURVEY)
 (DESCRIPTION FROM WEST 1/4 SECTION 26 - FOUND BRASS CAP AS REFERENCED ON CERTIFIED CORNER RECORD BY CLIFF BENNETT P.L.S 1815, FILED ON AUGUST 31, 2017. BENNETT SURVEYING FOUND (1) STEEL CORNER POST, (1) FIRE HYDRANT TOP OF NUT, AND A CHISELED "X" FOR REFERENCES. BENNETT VERIFIED NO CHANGES WERE MADE TO CORNER REFERENCES FROM SWO 5117(1) TO SWO 5117(2)

(FROM SWO 5117(2) SURVEY)
 CENTER SECTION 26 - FOUND 1/2" IRON PIN AS REFERENCED ON CERTIFIED CORNER RECORD BY CLIFF BENNETT P.L.S 1815, FILED ON AUGUST 31, 2017. BENNETT SURVEYING FOUND (2) 40D NAIL IN THE WEST FACE OF POWER POLE AND (1) 40D NAIL IN A 18" TREE VERIFIED FOR REFERENCES AS SHOWN BELOW ON BENNETT CERTIFIED CORNER RECORD. BENNETT VERIFIED NO CHANGES WERE MADE TO CORNER REFERENCES FROM SWO 5117(1) TO SWO 5117(2)

(FROM SWO 5117(2) SURVEY)
 WEST 1/4 SECTION 25 - FOUND PK NAIL AS REFERENCED ON CERTIFIED CORNER RECORD BY JACK B. WEAVER P.L.S 955, FILED ON FEBRUARY 19, 2009. BENNETT SURVEYING FOUND (1) 60D NAIL IN THE WEST FACE OF POWER POLE (1) FIRE HYDRANT TOP OF NUT AND (1) CHISELED "X" FOR REFERENCES.

(FROM SWO 5117(2) SURVEY)
 SOUTHWEST SECTION 25 - CORNER CALCULATED OFF OF PREVIOUS CERTIFIED CORNER RECORD BY JACK B. WEAVER FILED FEBRUARY 19, 2003. DUE TO HAZARDOUS TRAFFIC IN ROADWAY, COULD NOT SAFELY GET TO CORNER SECTION TO CONFIRM. BENNETT SURVEYING FOUND (1) NE INLET, SET (2) PK NAIL FOR REFERENCES.

(FROM SWO 5117(2) SURVEY)
 SOUTHWEST SECTION 26 - FOUND CHISELED "X" AS REFERENCED ON CERTIFIED CORNER RECORD BY CLIFF BENNETT P.L.S 1815, FILED ON AUGUST 31, 2017. BENNETT SURVEYING FOUND (3) 60D NAIL IN POWER POLES. BENNETT VERIFIED THAT NO CHANGES WERE MADE TO REFERENCES FROM SWO 5117(1) TO SWO 5117(2)

(FROM SWO 5117(2) SURVEY)
 S 1/4 SECTION 26 - FOUND BRASS CAP AS REFERENCED ON CERTIFIED CORNER RECORD BY CLIFF BENNETT P.L.S 1815, FILED ON AUGUST 31, 2017. BENNETT SURVEYING FOUND (3) 60D NAILS IN POWER POLE AS REFERENCES. BENNETT VERIFIED THAT NO CHANGES WERE MADE TO REFERENCES FROM SWO 5117(1) TO SWO 5117(2)



PLS		RDL	
DRAWN		RDL	
CHECKED			
APPROVED			
CREW		ISS	
COUNTY		TULSA	HIGHWAY US 75 STATE JOB NO. 33788(08)(11) SHEET NO S021

SURVEY DATA SHEET

SWO 5443(3)

OKLAHOMA DEPARTMENT OF TRANSPORTATION SURVEY DIVISION

R/W UTILITY MEETING

MARCH 2021

(FROM SWO 5117(2) SURVEY)
SOUTHWEST SECTION 26 - FOUND CHISELED "X" AS REFERENCED ON CERTIFIED CORNER RECORD BY CLIFF BENNETT P.L.S 1815, FILED ON AUGUST 31, 2017. BENNETT SURVEYING FOUND (3) 60D NAIL IN POWER POLES. BENNETT VERIFIED THAT NO CHANGES WERE MADE TO REFERENCES FROM S.W.O 5117(1) TO S.W.O 5117(2)

(FROM SWO 5117(2) SURVEY)
S 1/4 SECTION 26 - FOUND BRASS CAP AS REFERENCED ON CERTIFIED CORNER RECORD BY CLIFF BENNETT P.L.S 1815, FILED ON AUGUST 31, 2017. BENNETT SURVEYING FOUND (3) 60D NAILS IN POWER POLE AS REFERENCES. BENNETT VERIFIED THAT NO CHANGES WERE MADE TO REFERENCES FROM S.W.O 5117(1) TO S.W.O 5117(2)

(FROM SWO 5117(2) SURVEY)
SOUTHWEST SECTION 25 - CORNER CALCULATED OFF OF PREVIOUS CERTIFIED CORNER RECORD BY JACK B. WEAVER FILED FEBRUARY 19, 2003. DUE TO HAZARDOUS TRAFFIC IN ROADWAY, COULD NOT SAFELY GET TO CORNER SECTION TO CONFIRM. BENNETT SURVEYING FOUND (1) NE INLET, SET (2) PK NAIL FOR REFERENCES.

(FROM SWO 5117(2) SURVEY)
WEST 1/4 SECTION 35 - FOUND 1/2" IRON PIN AS REFERENCED ON CERTIFIED CORNER RECORD BY CLIFF BENNETT P.L.S 1815, ON AUGUST 31, 2017. BENNETT SURVEYING FOUND (1) 60D NAIL IN TREE, (1) 60D NAIL IN POWER POLE, (1) CHISELED "V", AND (1) CHISELED "X" FOR REFERENCES. BENNETT VERIFIED THAT NO CHANGES WERE MADE TO CORNER REFERENCE FROM S.W.O 5117(1) TO S.W.O 5117(2)

(FROM SWO 5117(2) SURVEY)
CENTER SECTION 35 - FOUND AND ACCEPTED 3/8TH IRON PIN W/SACK FOR THE ESTABLISHED MONUMENT. BENNETT SURVEYING FOUND (1) 1/2" IRON PIN, (1) 60D NAIL IN TREE, AND (1) WOOD CORNER POST AS REFERENCED ON OKLAHOMA CERTIFIED CORNER RECORD BY CLIFF BENNETT P.L.S 1815, DATED AUGUST 31, 2017. CONSIDER BENNETT'S PREVIOUS CORNER RECORD TO BE VOID.

(FROM SWO 5117(2) SURVEY)
WEST 1/4 SECTION 36 - FOUND 3/8" IRON PIN AS REFERENCED ON OKLAHOMA CERTIFIED CORNER RECORD BY LEE ALLEN SHROEDER, FILED AUGUST 1, 2014. BENNETT SURVEYING FOUND (1) MARKER SIGN (1) 60D NAIL IN POWER POLE, AND (1) NORTH FACE OF POWER POLE FOR REFERENCES.

T-62-1716
Southwest Corner of Section 35, T-19-N, R-12-E.
Found Cut X as described in CCR filed by Theodore A. Sack, LS 1139, on May 19, 2009.
Also found Brass Cap as described in CCRs filed by A.B. Watson Jr., LS 1057, on February 23, 1998, by J. Wesley Billis, LS 1135, on March 7, 1989, and by Leroy E. Higginbotham, LS 84, on October 30, 1978. Brass Cap also corresponds to adjacent highway legal descriptions as well as 61st Street Right of Way plans. Accepted Brass Cap as corner for this project and filed new CCR.

T-62-1717
South Quarter Corner of Section 35, T-19-N, R-12-E.
Found PK Nail at position described in CCR filed by A.B. Watson, LS 1057, on Feb. 23, 1998 which corresponds to monument described in CCRs filed by Leroy Higginbotham, LS 84, on Oct. 30, 1978, and by J. Wesley Billis, LS 1135, on March 7, 1989. Magnetic signal at point directly below PK Nail position. Accepted monument and filed new CCR.

T-62-1718
Southeast Corner of Section 35, T-19-N, R-12-E.
Found #4 Rebar at or near position described in CCRs filed by Lee Allen Shroeder, LS 1502, on July 10, 2014 and by A.B. Watson, LS 1057, on March 23, 1998. One reference found. Extensive search showed no other monuments in area. Accepted monument position and filed new CCR.

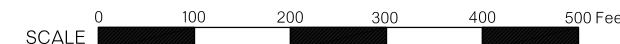
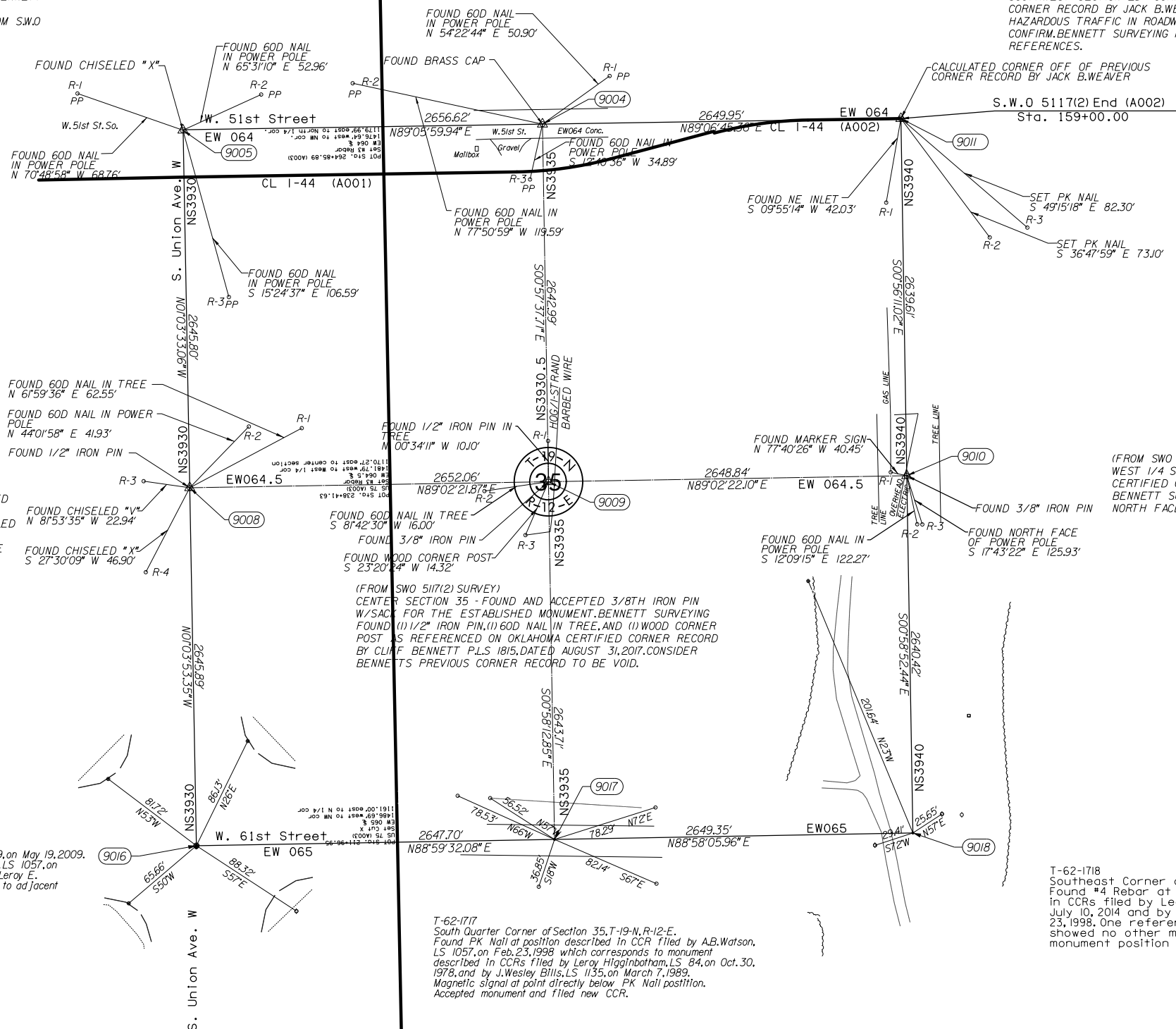

PLS	RDL		
DRAWN	RDL		
CHECKED			
APPROVED			
CREW	ISS		
COUNTY	TULSA	HIGHWAY	US 75

OKLAHOMA DEPARTMENT OF TRANSPORTATION
SURVEY DIVISION

SURVEY DATA SHEET
SWO 5443(3)

COUNTY TULSA HIGHWAY US 75 STATE JOB NO. 33788(08)(11) SHEET NO S022

R/W UTILITY MEETING

MARCH 2021

T-62-1716
 Northwest Corner of Section 2, T-18-N, R-12-E.
 Found Cut X as described in CCR filed by Theodore A. Sack, LS 1139, on May 19, 2009.
 Also found Brass Cap as described in CCRs filed by A.B. Watson, Jr., LS 1057, on February 23, 1998, by J. Wesley Bills, LS 1135, on March 7, 1989, and by Leroy E. Higginbotham, LS 84, on October 30, 1978. Brass Cap position also corresponds to adjacent highway legal descriptions as well as 61st Street Right of Way plans.
 Accepted Brass Cap as corner for this project and filed new CCR.

T-62-1717
 South Quarter Corner of Section 35, T-19-N, R-12-E.
 Found PK Nail at position described in CCR filed by A.B. Watson, LS 1057, on Feb. 23, 1998 which corresponds to monument described in CCRs filed by Leroy Higginbotham, LS 84, on Oct. 30, 1978, and by J. Wesley Bills, LS 1135, on March 7, 1989.
 Magnetic signal at point directly below PK Nail position.
 Accepted monument and filed new CCR.

T-62-1718
 Southeast Corner of Section 35, T-19-N, R-12-E. Found #4 Rebar at or near position described in CCRs filed by Lee Allen Schroeder, LS 1502, on July 10, 2014 and by A.B. Watson, LS 1057, on March 23, 1998. One reference found. Extensive search showed no other monuments in area. Accepted monument position and filed new CCR.

T-62-1721
 West Quarter Corner of Section 2, T-18-N, R-12-E.
 Found Brass Cap at position described in CCRs filed by Randy L. Marquardt, LS 1432, on Oct. 19, 2007, by A.B. Watson, Jr., LS 1057, on Feb. 23, 1998, and by J. Wesley Bills, LS 1135, on March 7, 1989. Found multiple supporting references. Accepted monument and filed new CCR.

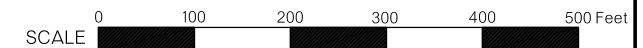
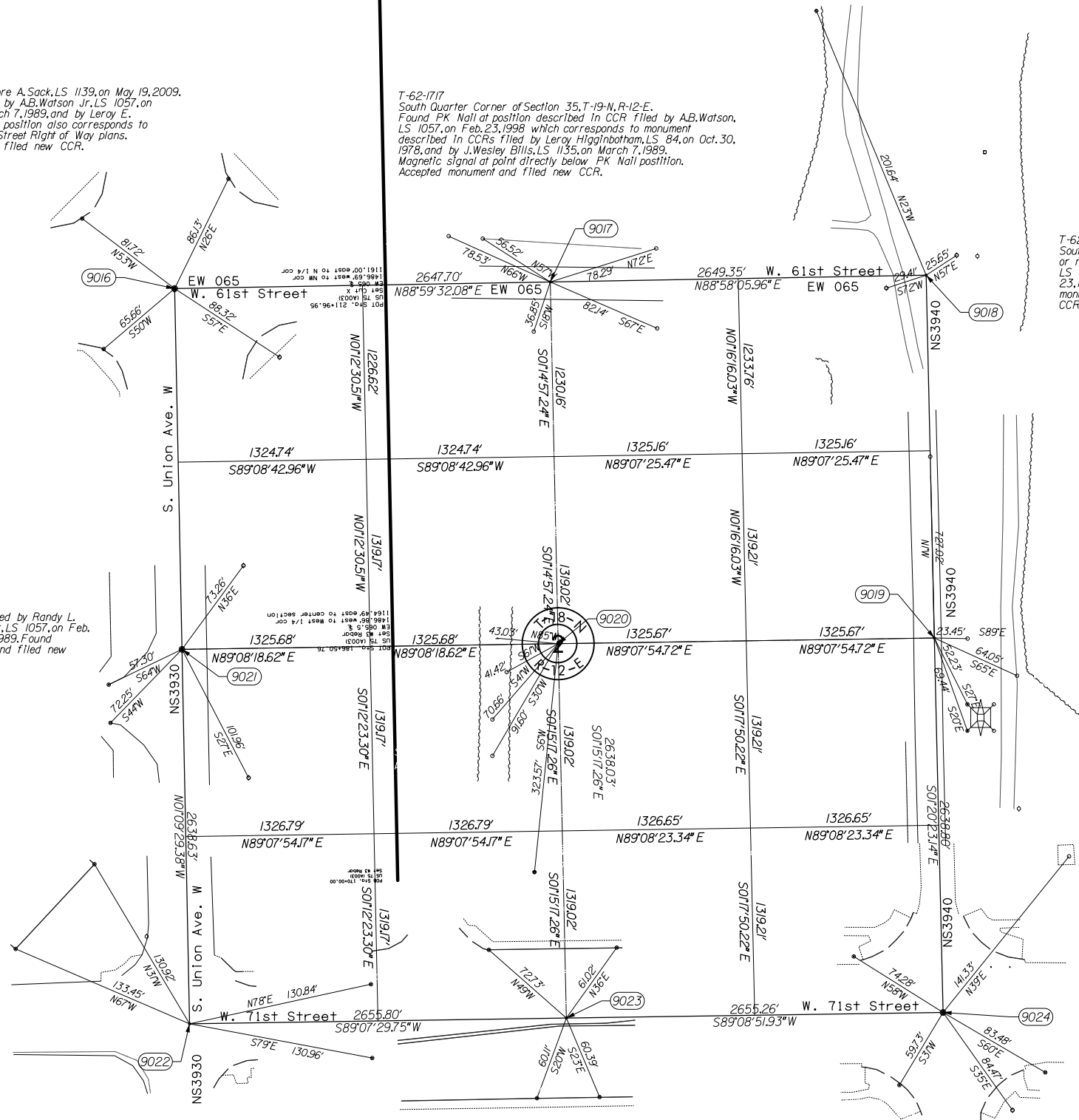

PLS		RDL	
DRAWN		RDL	
CHECKED			
APPROVED			
CREW		ISS	
COUNTY		TULSA	HIGHWAY US 75 STATE JOB NO. 33788(08)(11) SHEET NO S023

OKLAHOMA DEPARTMENT OF TRANSPORTATION SURVEY DIVISION

SURVEY DATA SHEET

SWO 5443(3)

2/26/2021

SEC. 35
T-19-N, R-12-E

SEC. 26
T-19-N, R-12-E

OKLAHOMA DEPARTMENT OF TRANSPORTATION

R/W UTILITY MEETING

MARCH 2021

LEGEND

- ① 4" SOLID WHITE LINE
- ② 4" SOLID YELLOW LINE
- ③ 4" DOUBLE YELLOW BARRIER LINE
- ④ 4" DASHED WHITE LINE
- ⑤ 4" DASHED YELLOW LINE
- ⑥ 6" SOLID WHITE EDGE LINE
- ⑦ 6" SOLID YELLOW EDGE LINE
- ⑧ 6" DASHED LANE LINE (WHITE/BLACK)
- ⑨ 6" DOTTED LANE LINE (WHITE/BLACK)
- ⑩ 8" DOTTED LANE LINE (WHITE/BLACK)
- ⑪ 8" SOLID WHITE LINE
- ⑫ 8" YELLOW GORE MARKING (15' C/C)
- ⑬ 12" WHITE GORE MARKING (10' C/C)
- ⊗ REMOVE SIGN (SEE SUMMARY OF SIGN REMOVALS)

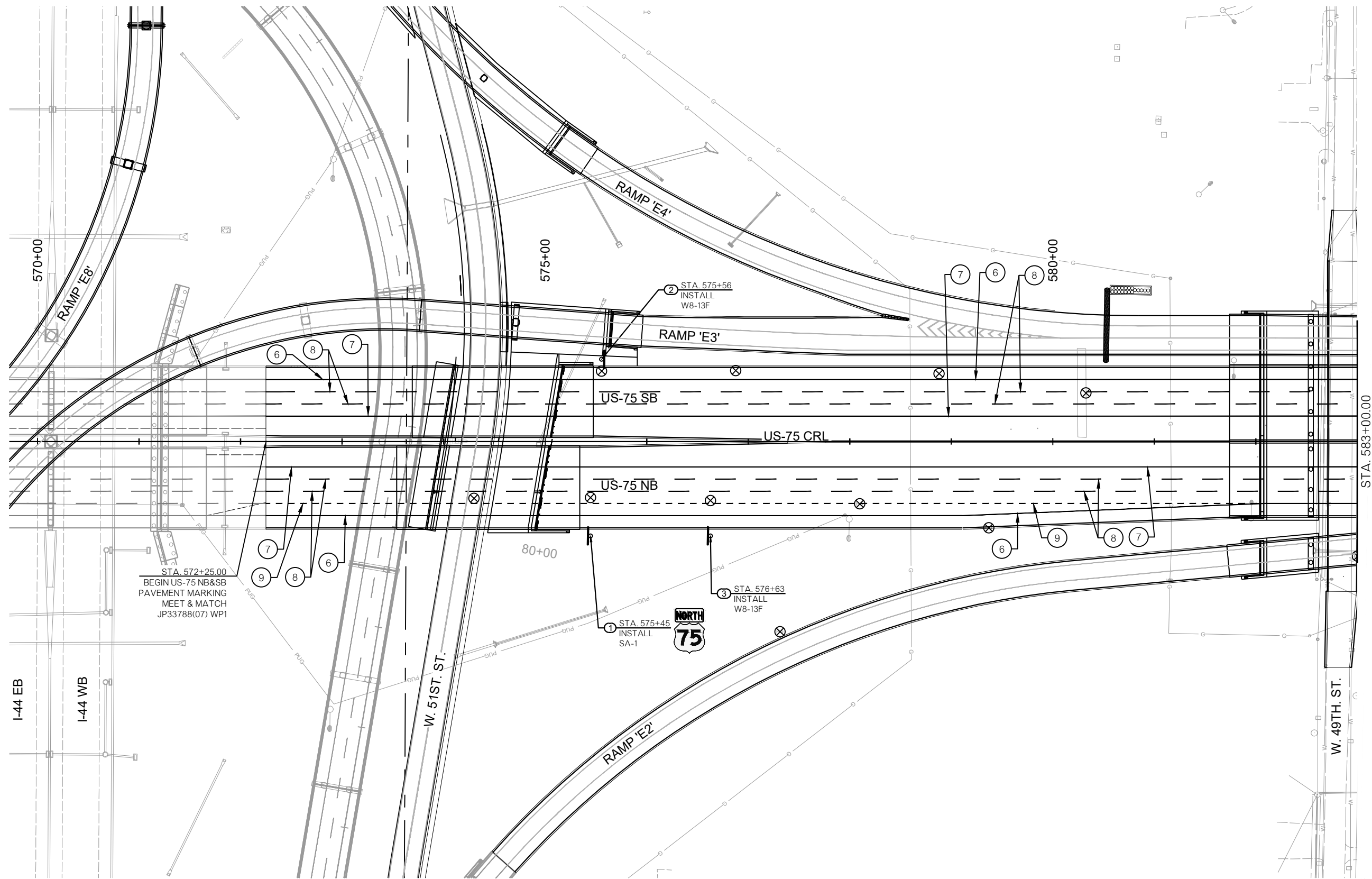

SEC. 35
T-19-N, R-12-E

SEC. 26
T-19-N, R-12-E

OKLAHOMA DEPARTMENT OF TRANSPORTATION

DESIGN	REH	3/2021
DRAWN	JMJ	3/2021
CHECKED	JRW	3/2021
APPROVED	EMS	3/2021
SQUAD	LEE	

SIGNING & MARKING PLAN

US-75 CRL - SHEET 1 OF 5
STA. 572+25 TO STA. 583+00

COUNTY TULSA HIGHWAY US-75 STATE JOB NO. 33788(11) SHEET NO. T001

JP3378808 - SS - WP5.dwg

2/26/2021

SEC. 26
T-19-N, R-12-E

R/W UTILITY
MEETING
MARCH 2021

LEGEND

1	4" SOLID WHITE LINE
2	4" SOLID YELLOW LINE
3	4" DOUBLE YELLOW BARRIER LINE
4	4" DASHED WHITE LINE
5	4" DASHED YELLOW LINE
6	6" SOLID WHITE EDGE LINE
7	6" SOLID YELLOW EDGE LINE
8	6" DASHED LANE LINE (WHITE/BLACK)
9	6" DOTTED LANE LINE (WHITE/BLACK)
10	8" DOTTED LANE LINE (WHITE/BLACK)
11	8" SOLID WHITE LINE
12	8" YELLOW GORE MARKING (15' C/C)
13	12" WHITE GORE MARKING (10' C/C)
⊗	REMOVE SIGN (SEE SUMMARY OF SIGN REMOVALS)

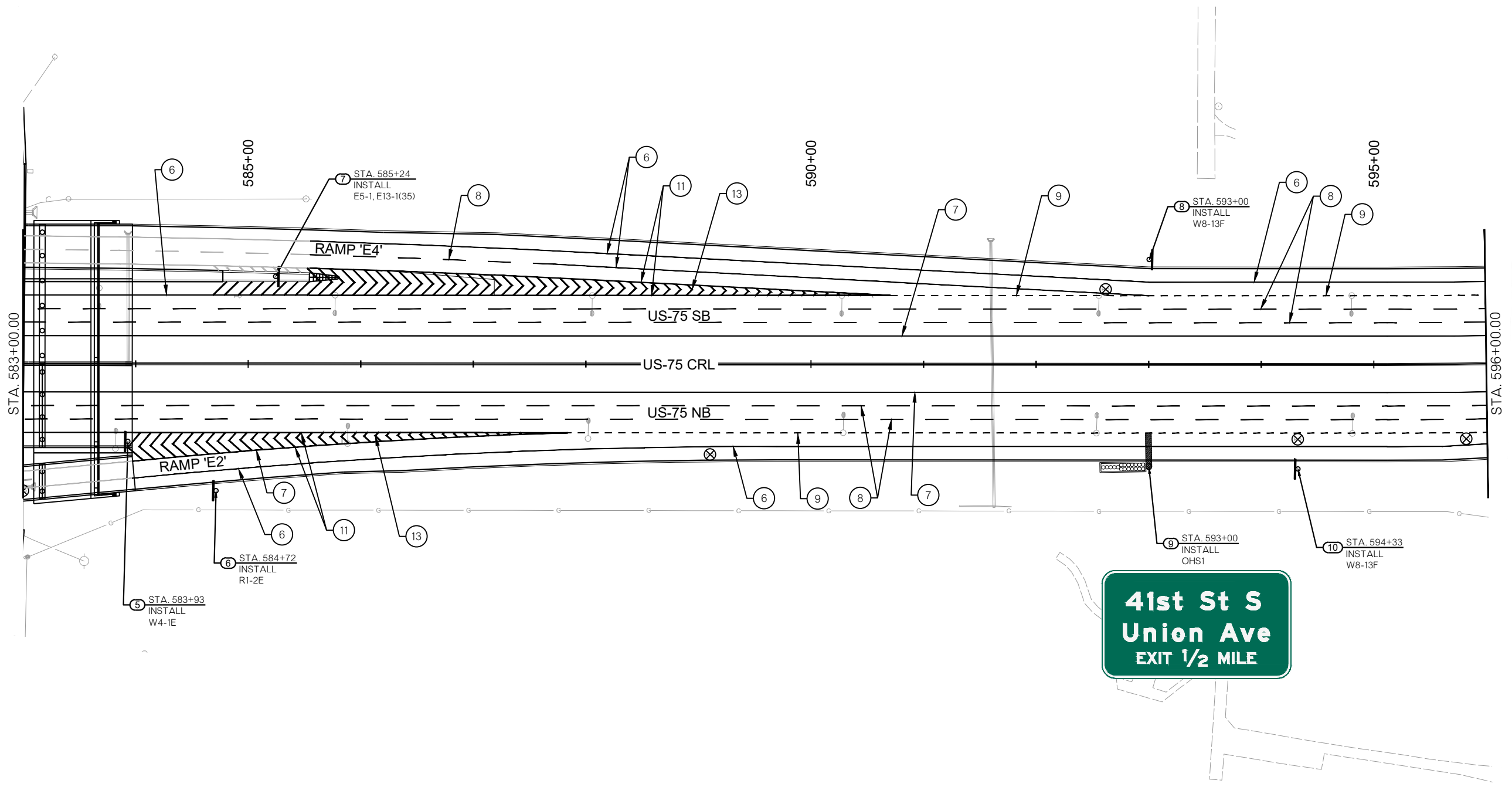

SEC. 26
T-19-N, R-12-E

DESIGN	REH	3/2021	OKLAHOMA DEPARTMENT OF TRANSPORTATION
DRAWN	JMJ	3/2021	
CHECKED	JRW	3/2021	
APPROVED	EMS	3/2021	
SQUAD	LEE		
COUNTY TULSA HIGHWAY US-75 STATE JOB NO. 33788(11) SHEET NO. T002			

J:\33788(11) - SS - WP5.dwg

2/26/2021

SEC. 26
T-19-N, R-12-E

R/W UTILITY MEETING
MARCH 2021

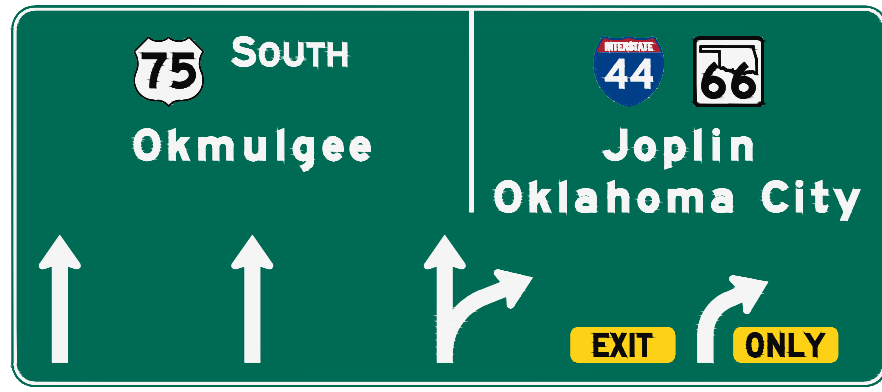
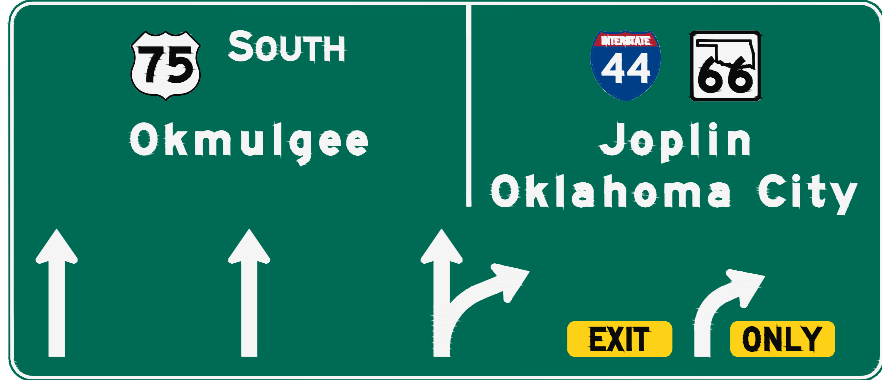

- LEGEND**
- ① 4" SOLID WHITE LINE
 - ② 4" SOLID YELLOW LINE
 - ③ 4" DOUBLE YELLOW BARRIER LINE
 - ④ 4" DASHED WHITE LINE
 - ⑤ 4" DASHED YELLOW LINE
 - ⑥ 6" SOLID WHITE EDGE LINE
 - ⑦ 6" SOLID YELLOW EDGE LINE
 - ⑧ 6" DASHED LANE LINE (WHITE/BLACK)
 - ⑨ 6" DOTTED LANE LINE (WHITE/BLACK)
 - ⑩ 8" DOTTED LANE LINE (WHITE/BLACK)
 - ⑪ 8" SOLID WHITE LINE
 - ⑫ 8" YELLOW GORE MARKING (15' C/C)
 - ⑬ 12" WHITE GORE MARKING (10' C/C)
 - ⊗ REMOVE SIGN (SEE SUMMARY OF SIGN REMOVALS)

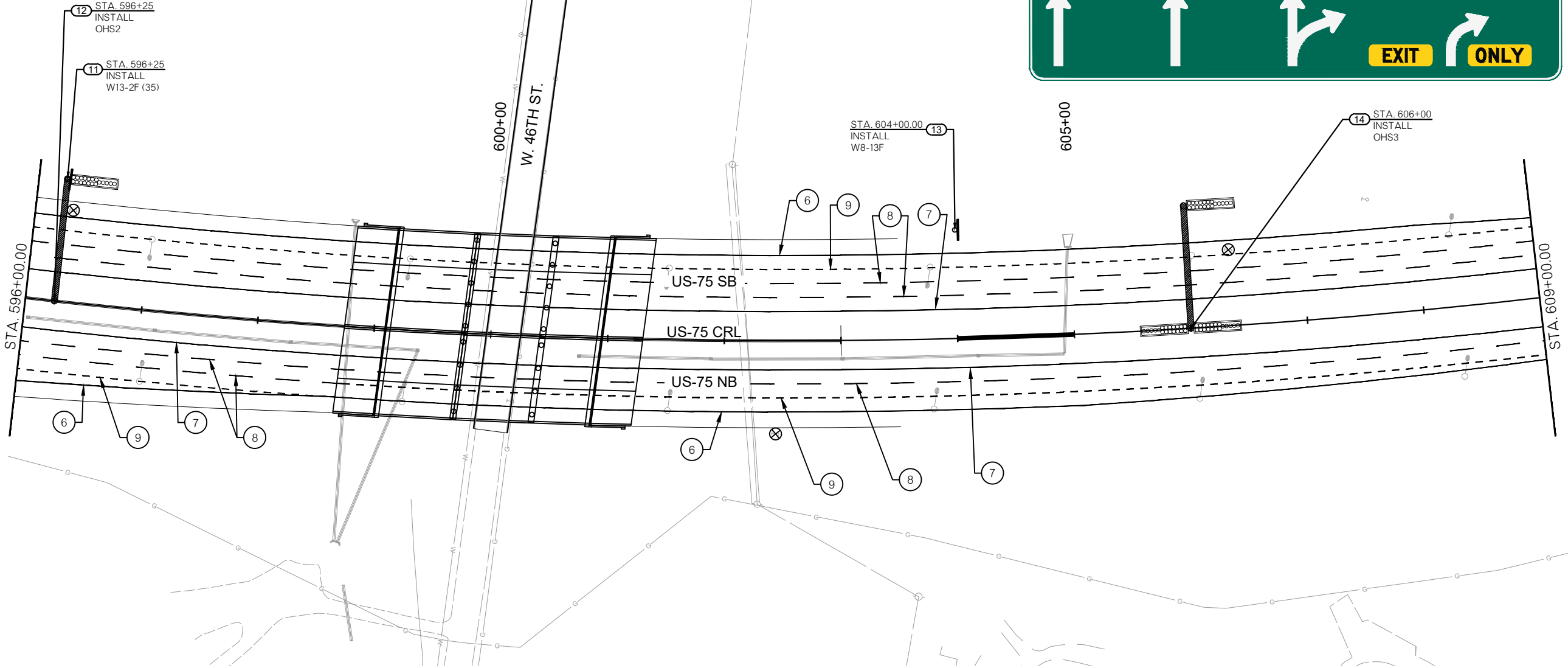

SEC. 26
T-19-N, R-12-E

DESIGN	REH	3/2021	OKLAHOMA DEPARTMENT OF TRANSPORTATION
DRAWN	JMJ	3/2021	
CHECKED	JRW	3/2021	
APPROVED	EMS	3/2021	
SQUAD	LEE		
SIGNING & MARKING PLAN			
US-75 CRL - SHEET 3 OF 5			
STA. 596+00 TO STA. 609+00			
COUNTY	TULSA	HIGHWAY	US-75 STATE JOB NO. 33788(11) SHEET NO. T003

J:\33788(11) - SS - WP5.dwg

2/26/2021

SEC. 26
T-19-N, R-12-E

OKLAHOMA DEPARTMENT OF TRANSPORTATION

R/W UTILITY
MEETING
MARCH 2021

LEGEND

1	4" SOLID WHITE LINE
2	4" SOLID YELLOW LINE
3	4" DOUBLE YELLOW BARRIER LINE
4	4" DASHED WHITE LINE
5	4" DASHED YELLOW LINE
6	6" SOLID WHITE EDGE LINE
7	6" SOLID YELLOW EDGE LINE
8	6" DASHED LANE LINE (WHITE/BLACK)
9	6" DOTTED LANE LINE (WHITE/BLACK)
10	8" DOTTED LANE LINE (WHITE/BLACK)
11	8" SOLID WHITE LINE
12	8" YELLOW GORE MARKING (15' C/C)
13	12" WHITE GORE MARKING (10' C/C)
⊗	REMOVE SIGN (SEE SUMMARY OF SIGN REMOVALS)

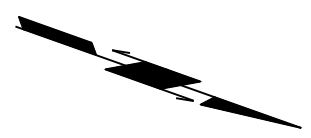
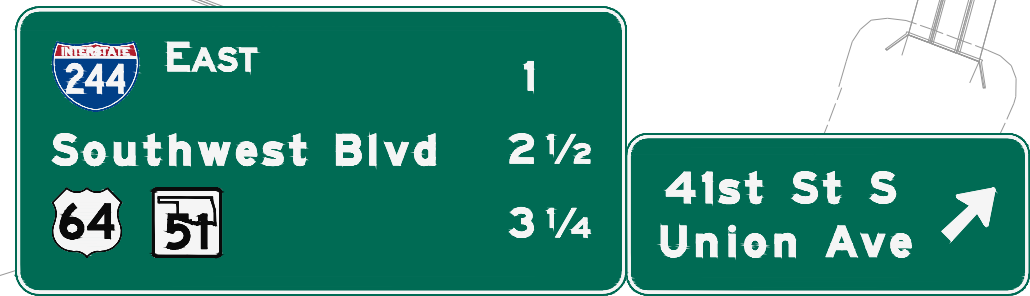
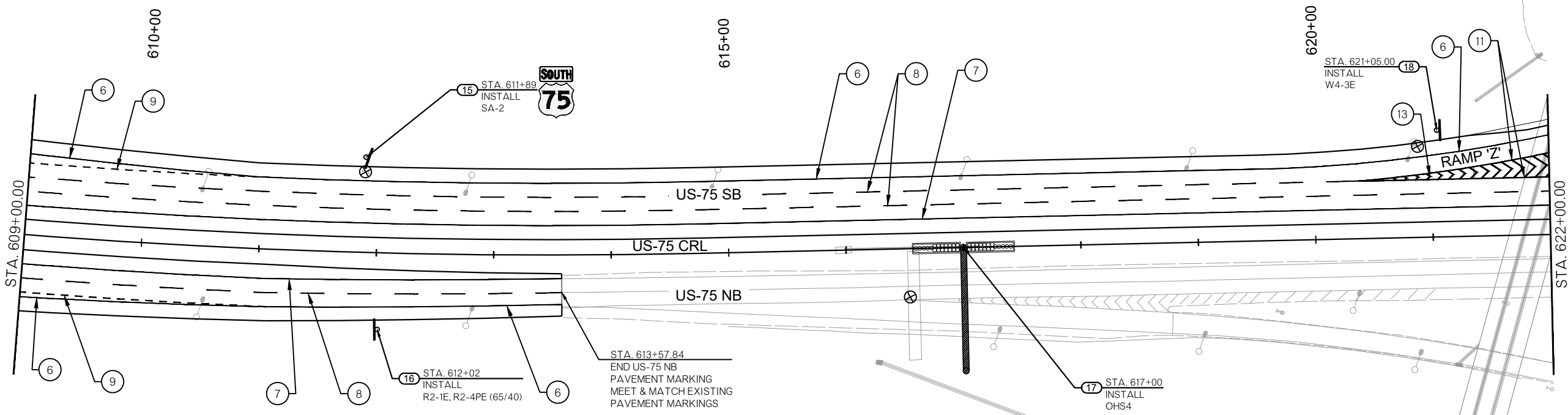

J:\3378808 - SS - WP5.dwg

SEC. 26
T-19-N, R-12-E

DESIGN	REH	3/2021	OKLAHOMA DEPARTMENT OF TRANSPORTATION
DRAWN	JMJ	3/2021	
CHECKED	JRW	3/2021	
APPROVED	EMS	3/2021	
SQUAD	LEE		
SIGNING & MARKING PLAN			
US-75 CRL - SHEET 4 OF 5			
STA. 609+00 TO STA. 622+00			
COUNTY	TULSA	HIGHWAY	US-75
STATE JOB NO.	33788(11)	SHEET NO.	T004

2/26/2021

SEC. 26
T-19-N, R-12-E

SEC. 23
T-19-N, R-12-E

OKLAHOMA DEPARTMENT OF TRANSPORTATION

R/W UTILITY MEETING

MARCH 2021

LEGEND

- ① 4" SOLID WHITE LINE
- ② 4" SOLID YELLOW LINE
- ③ 4" DOUBLE YELLOW BARRIER LINE
- ④ 4" DASHED WHITE LINE
- ⑤ 4" DASHED YELLOW LINE
- ⑥ 6" SOLID WHITE EDGE LINE
- ⑦ 6" SOLID YELLOW EDGE LINE
- ⑧ 6" DASHED LANE LINE (WHITE/BLACK)
- ⑨ 6" DOTTED LANE LINE (WHITE/BLACK)
- ⑩ 8" DOTTED LANE LINE (WHITE/BLACK)
- ⑪ 8" SOLID WHITE LINE
- ⑫ 8" YELLOW GORE MARKING (15' C/C)
- ⑬ 12" WHITE GORE MARKING (10' C/C)
- ⊗ REMOVE SIGN (SEE SUMMARY OF SIGN REMOVALS)

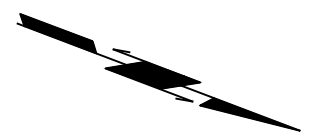
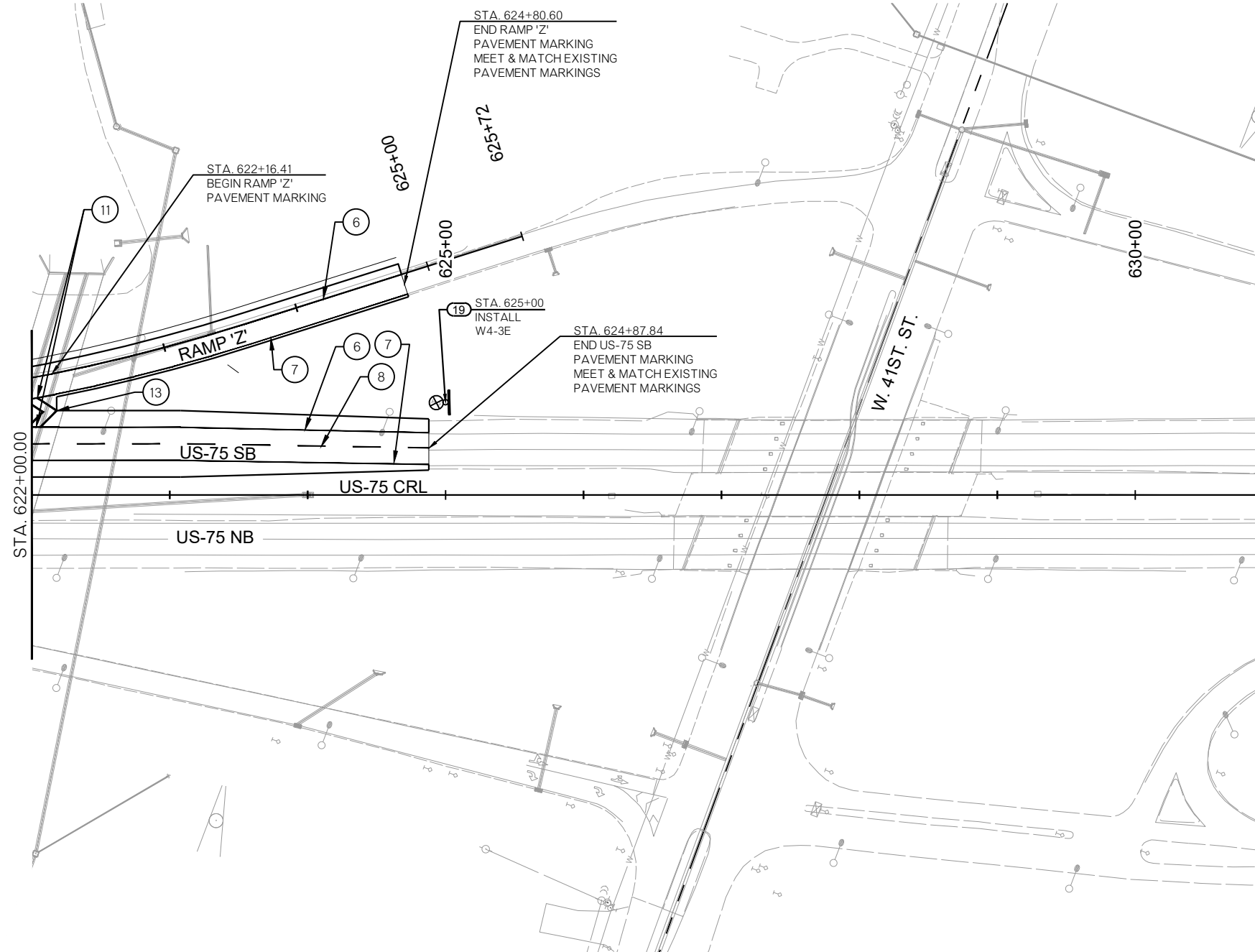

SEC. 26
T-19-N, R-12-E

SEC. 23
T-19-N, R-12-E

DESIGN	REH	3/2021	OKLAHOMA DEPARTMENT OF TRANSPORTATION SIGNING & MARKING PLAN US-75 CRL - SHEET 5 OF 5 STA. 622+00 TO STA. 624+88
DRAWN	JMJ	3/2021	
CHECKED	JRW	3/2021	
APPROVED	EMS	3/2021	
SQUAD	LEE		
COUNTY TULSA HIGHWAY US-75 STATE JOB NO. 33788(11) SHEET NO. T005			

J:\33788(11) - SS - WP5.dwg

2/26/2021

R/W UTILITY MEETING

MARCH 2021

LEGEND

- ① 4" SOLID WHITE LINE
- ② 4" SOLID YELLOW LINE
- ③ 4" DOUBLE YELLOW BARRIER LINE
- ④ 4" DASHED WHITE LINE
- ⑤ 4" DASHED YELLOW LINE
- ⑥ 6" SOLID WHITE EDGE LINE
- ⑦ 6" SOLID YELLOW EDGE LINE
- ⑧ 6" DASHED LANE LINE (WHITE/BLACK)
- ⑨ 6" DOTTED LANE LINE (WHITE/BLACK)
- ⑩ 8" DOTTED LANE LINE (WHITE/BLACK)
- ⑪ 8" SOLID WHITE LINE
- ⑫ 8" YELLOW GORE MARKING (15' C/C)
- ⑬ 12" WHITE GORE MARKING (10' C/C)
- ⊕ REMOVE SIGN (SEE SUMMARY OF SIGN REMOVALS)

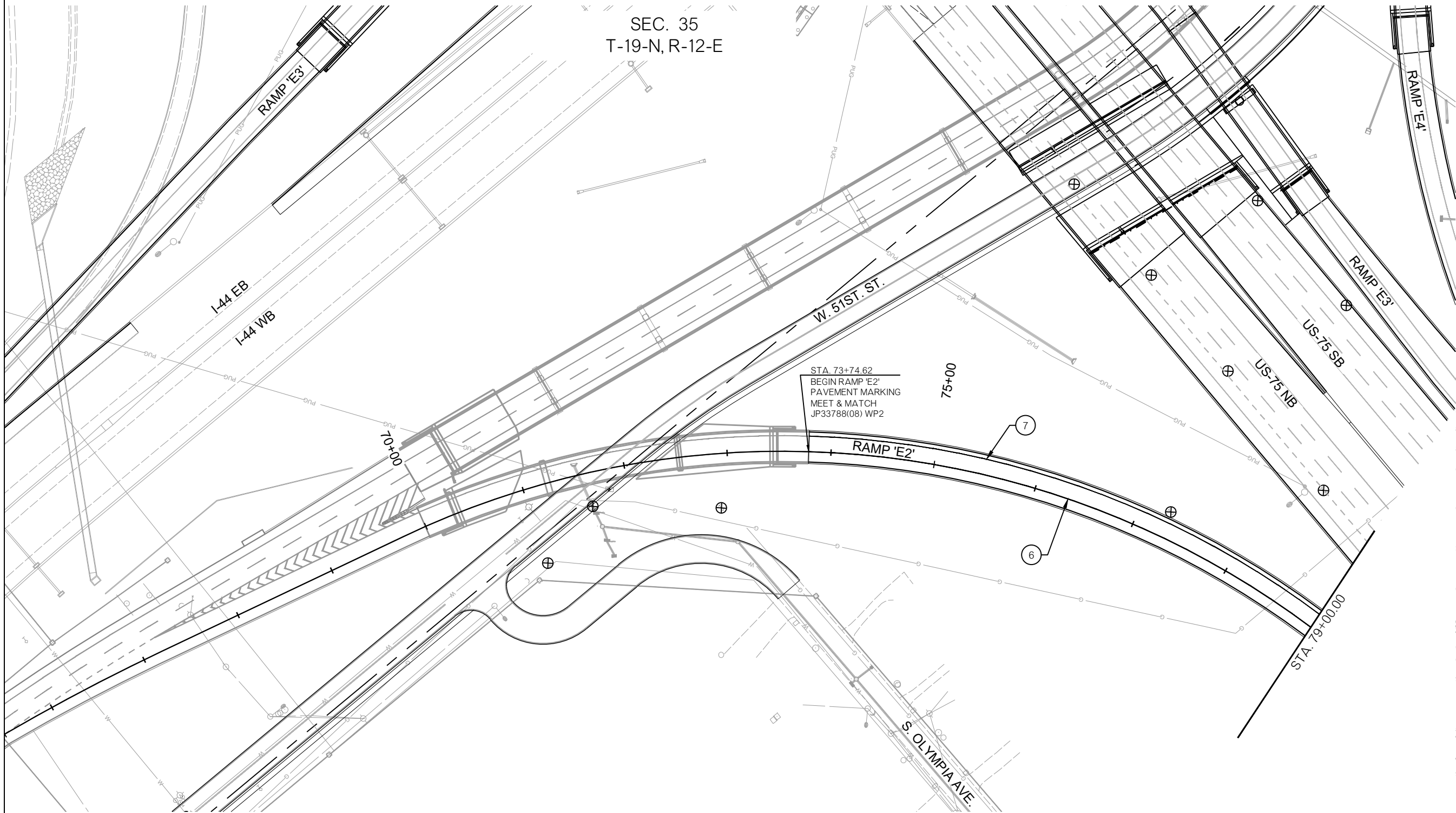

STA. 73+74.62
 BEGIN RAMP 'E2'
 PAVEMENT MARKING
 MEET & MATCH
 JP33788(08) WP2

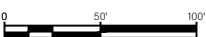
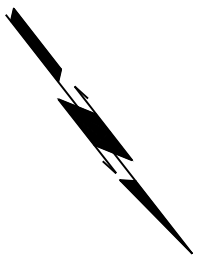

SEC. 26
 T-19-N, R-12-E

DESIGN	REH	3/2021	OKLAHOMA DEPARTMENT OF TRANSPORTATION
DRAWN	JMJ	3/2021	
CHECKED	JRW	3/2021	
APPROVED	EMS	3/2021	
SQUAD	LEE		
SIGNING & MARKING PLAN			
RAMP 'E2' CRL - SHEET 2 OF 2			
STA. 73+75 TO STA. 79+00			
COUNTY	TULSA	HIGHWAY	US-75 STATE JOB NO. 33788(11) SHEET NO. T006

JP3378808 - SS - WP5.dwg

2/26/2021

JP3378808 - SS - WP5.dwg

SEC. 26
T-19-N, R-12-E

OKLAHOMA DEPARTMENT OF TRANSPORTATION

R/W UTILITY
MEETING

MARCH 2021

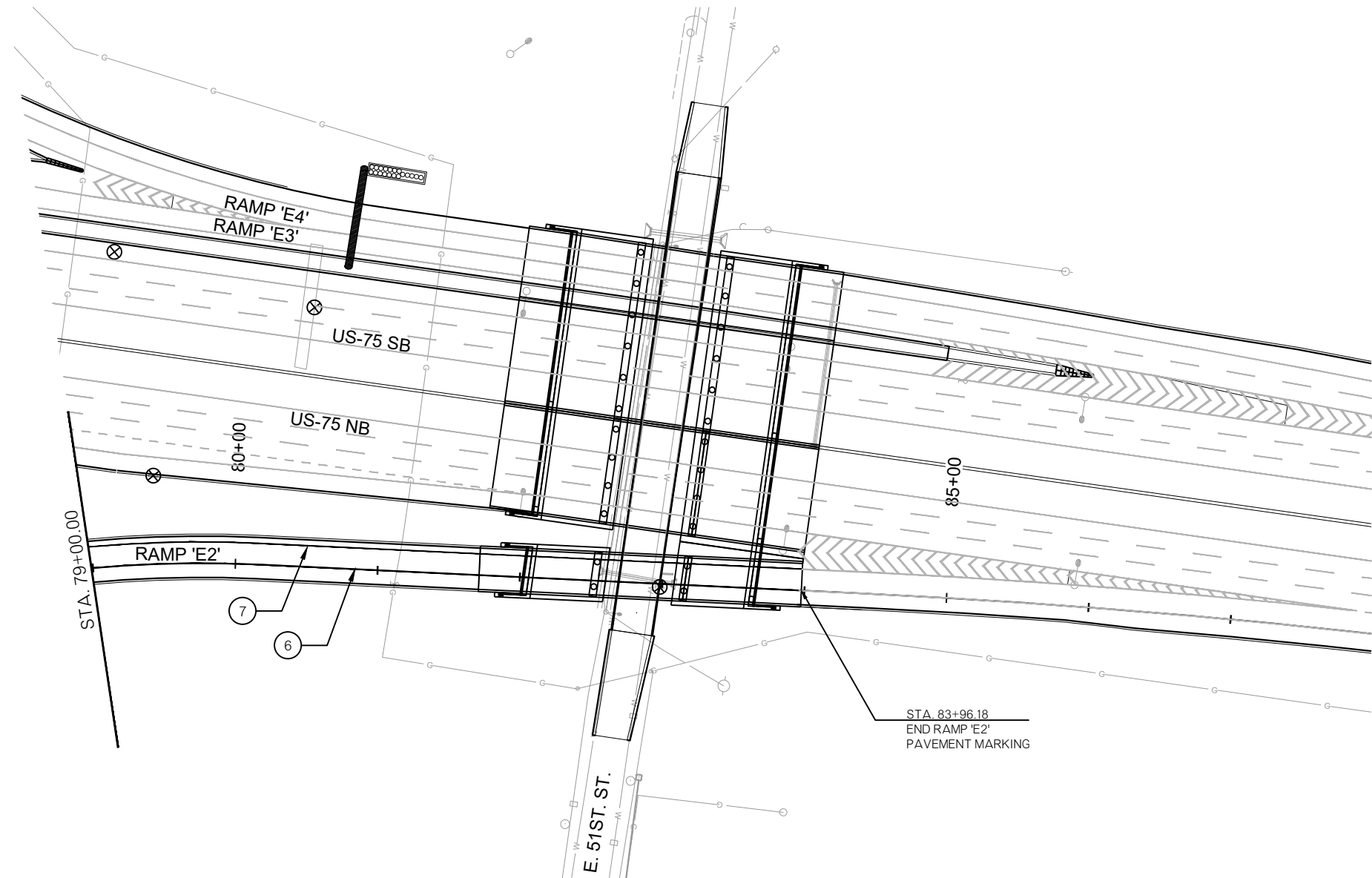

LEGEND

1	4" SOLID WHITE LINE
2	4" SOLID YELLOW LINE
3	4" DOUBLE YELLOW BARRIER LINE
4	4" DASHED WHITE LINE
5	4" DASHED YELLOW LINE
6	6" SOLID WHITE EDGE LINE
7	6" SOLID YELLOW EDGE LINE
8	6" DASHED LANE LINE (WHITE/BLACK)
9	6" DOTTED LANE LINE (WHITE/BLACK)
10	8" DOTTED LANE LINE (WHITE/BLACK)
11	8" SOLID WHITE LINE
12	8" YELLOW GORE MARKING (15' C/C)
13	12" WHITE GORE MARKING (10' C/C)
⊗	REMOVE SIGN (SEE SUMMARY OF SIGN REMOVALS)

SEC. 26
T-19-N, R-12-E

DESIGN	REH	3/2021	OKLAHOMA DEPARTMENT OF TRANSPORTATION
DRAWN	JMJ	3/2021	
CHECKED	JRW	3/2021	
APPROVED	EMS	3/2021	
SQUAD	LEE		
COUNTY TULSA HIGHWAY US-75 STATE JOB NO. 33788(11) SHEET NO. T007			

OKLAHOMA DEPARTMENT OF TRANSPORTATION

SIGNING & MARKING PLAN

RAMP 'E2' CRL - SHEET 2 OF 2
STA. 79+00 TO STA. 83+96

2/26/2021

SEC. 26
T-19-N, R-12-E

SEC. 35
T-19-N, R-12-E

OKLAHOMA DEPARTMENT OF TRANSPORTATION

R/W UTILITY MEETING

MARCH 2021

LEGEND

- ① 4" SOLID WHITE LINE
- ② 4" SOLID YELLOW LINE
- ③ 4" DOUBLE YELLOW BARRIER LINE
- ④ 4" DASHED WHITE LINE
- ⑤ 4" DASHED YELLOW LINE
- ⑥ 6" SOLID WHITE EDGE LINE
- ⑦ 6" SOLID YELLOW EDGE LINE
- ⑧ 6" DASHED LANE LINE (WHITE/BLACK)
- ⑨ 6" DOTTED LANE LINE (WHITE/BLACK)
- ⑩ 8" DOTTED LANE LINE (WHITE/BLACK)
- ⑪ 8" SOLID WHITE LINE
- ⑫ 8" YELLOW GORE MARKING (15' C/C)
- ⑬ 12" WHITE GORE MARKING (10' C/C)
- ⊗ REMOVE SIGN (SEE SUMMARY OF SIGN REMOVALS)

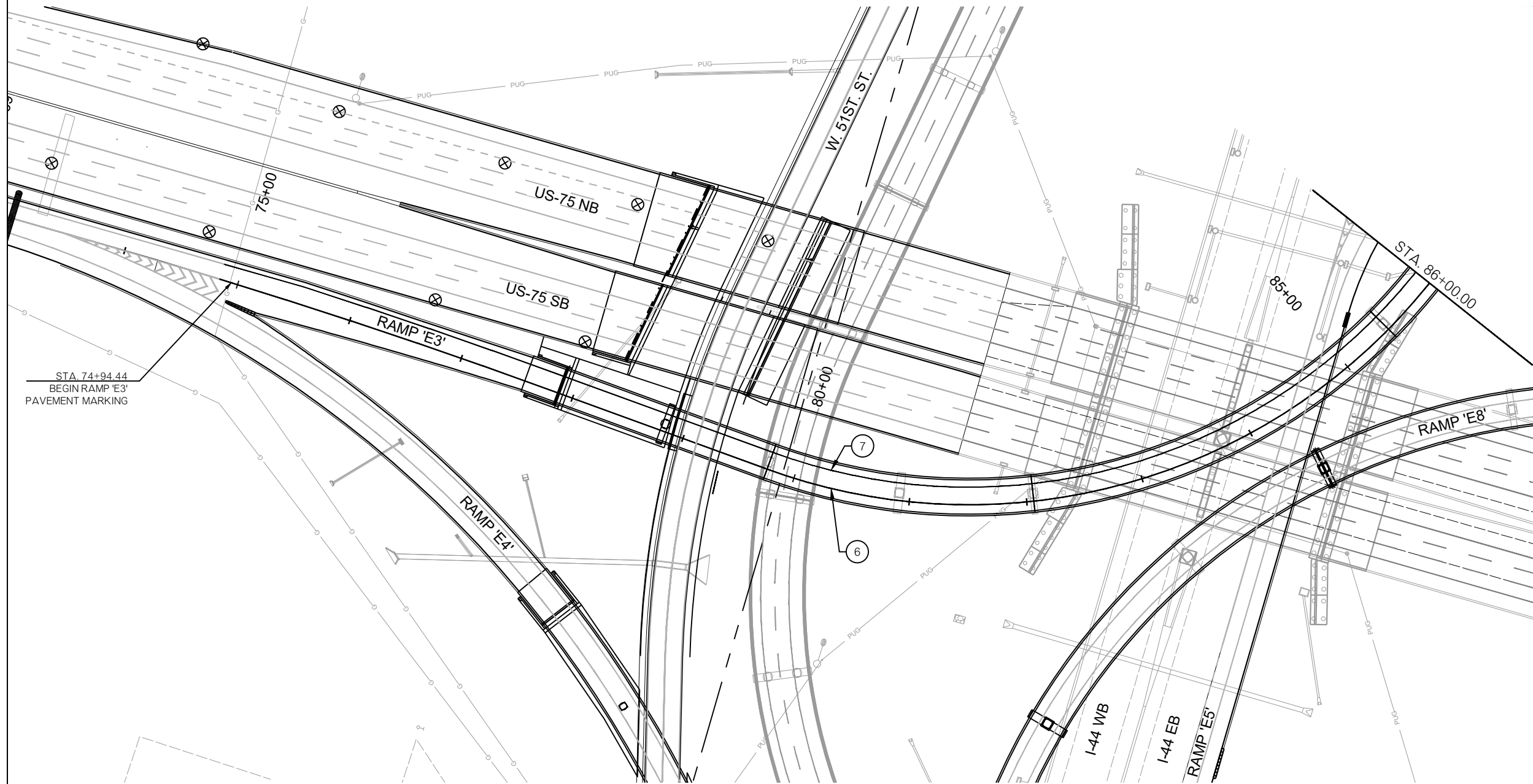

STA. 74+94.44
BEGIN RAMP 'E3'
PAVEMENT MARKING

SEC. 26
T-19-N, R-12-E

SEC. 35
T-19-N, R-12-E

DESIGN	REH	3/2021
DRAWN	JMJ	3/2021
CHECKED	JRW	3/2021
APPROVED	EMS	3/2021
SQUAD	LEE	

OKLAHOMA DEPARTMENT OF TRANSPORTATION

SIGNING & MARKING PLAN

RAMP 'E3' CRL - SHEET 1 OF 2
STA. 74+94 TO STA. 86+00

COUNTY **TULSA** HIGHWAY **US-75** STATE JOB NO. **33788(11)** SHEET NO. **T008**

J:\3378808 - SS - WP5.dwg

2/26/2021

SEC. 26
T-19-N, R-12-E

OKLAHOMA DEPARTMENT OF TRANSPORTATION

R/W UTILITY
MEETING

MARCH 2021

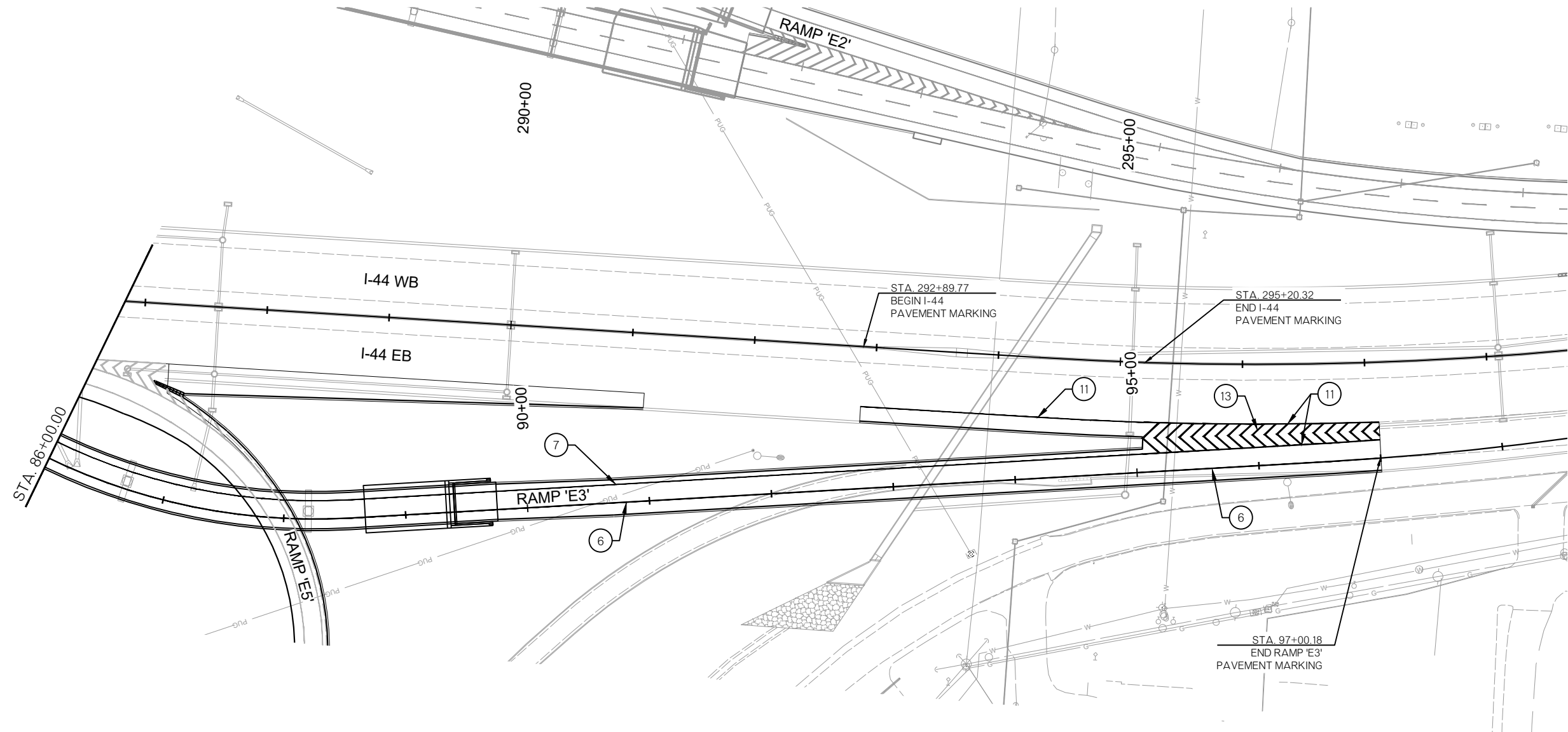

LEGEND

1	4" SOLID WHITE LINE
2	4" SOLID YELLOW LINE
3	4" DOUBLE YELLOW BARRIER LINE
4	4" DASHED WHITE LINE
5	4" DASHED YELLOW LINE
6	6" SOLID WHITE EDGE LINE
7	6" SOLID YELLOW EDGE LINE
8	6" DASHED LANE LINE (WHITE/BLACK)
9	6" DOTTED LANE LINE (WHITE/BLACK)
10	8" DOTTED LANE LINE (WHITE/BLACK)
11	8" SOLID WHITE LINE
12	8" YELLOW GORE MARKING (15' C/C)
13	12" WHITE GORE MARKING (10' C/C)
⊗	REMOVE SIGN (SEE SUMMARY OF SIGN REMOVALS)

J:\3378808 - SS - WP5.dwg

SEC. 35
T-19-N, R-12-E

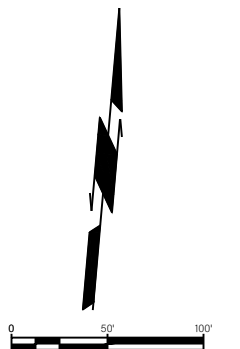

DESIGN	REH	3/2021	OKLAHOMA DEPARTMENT OF TRANSPORTATION
DRAWN	JMJ	3/2021	
CHECKED	JRW	3/2021	
APPROVED	EMS	3/2021	
SQUAD	LEE		
COUNTY TULSA HIGHWAY US-75 STATE JOB NO. 33788(11) SHEET NO. T009			

SIGNING & MARKING PLAN
RAMP 'E3' CRL - SHEET 2 OF 2
STA. 86+00 TO STA. 97+00

2/26/2021

SEC. 26
T-19-N, R-12-E

R/W UTILITY
MEETING
MARCH 2021

LEGEND

1	4" SOLID WHITE LINE
2	4" SOLID YELLOW LINE
3	4" DOUBLE YELLOW BARRIER LINE
4	4" DASHED WHITE LINE
5	4" DASHED YELLOW LINE
6	6" SOLID WHITE EDGE LINE
7	6" SOLID YELLOW EDGE LINE
8	6" DASHED LANE LINE (WHITE/BLACK)
9	6" DOTTED LANE LINE (WHITE/BLACK)
10	8" DOTTED LANE LINE (WHITE/BLACK)
11	8" SOLID WHITE LINE
12	8" YELLOW GORE MARKING (15' C/C)
13	12" WHITE GORE MARKING (10' C/C)
⊗	REMOVE SIGN (SEE SUMMARY OF SIGN REMOVALS)

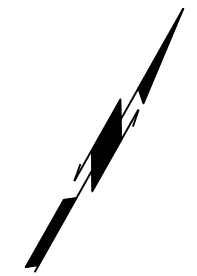
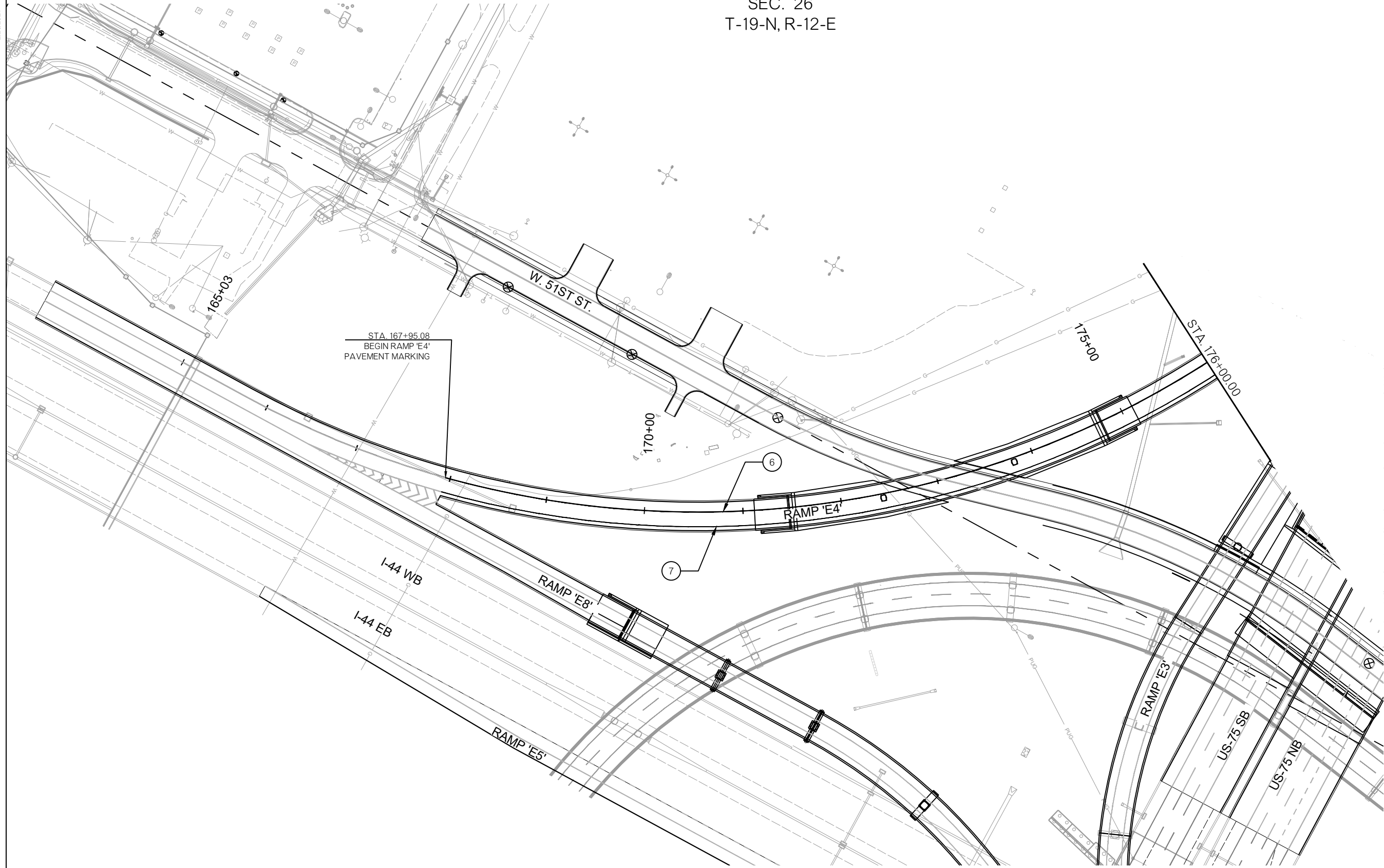

JP3378808 - SS - WP5.dwg

SEC. 35
T-19-N, R-12-E

DESIGN	REH	3/2021	OKLAHOMA DEPARTMENT OF TRANSPORTATION
DRAWN	JMJ	3/2021	
CHECKED	JRW	3/2021	
APPROVED	EMS	3/2021	
SQUAD	LEE		
COUNTY TULSA			OKLAHOMA DEPARTMENT OF TRANSPORTATION
HIGHWAY US-75			SIGNING & MARKING PLAN
STATE JOB NO. 33788(11)			RAMP 'E4' CRL - SHEET 1 OF 2
SHEET NO. T010			STA. 167+95 TO STA. 176+00

SEC. 26
T-19-N, R-12-E

R/W UTILITY
MEETING

MARCH 2021

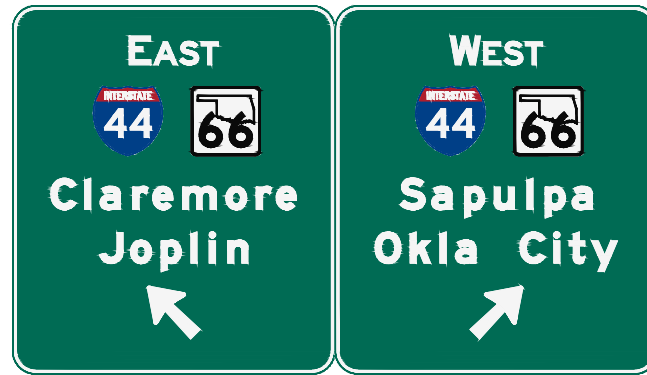

LEGEND

1	4" SOLID WHITE LINE
2	4" SOLID YELLOW LINE
3	4" DOUBLE YELLOW BARRIER LINE
4	4" DASHED WHITE LINE
5	4" DASHED YELLOW LINE
6	6" SOLID WHITE EDGE LINE
7	6" SOLID YELLOW EDGE LINE
8	6" DASHED LANE LINE (WHITE/BLACK)
9	6" DOTTED LANE LINE (WHITE/BLACK)
10	8" DOTTED LANE LINE (WHITE/BLACK)
11	8" SOLID WHITE LINE
12	8" YELLOW GORE MARKING (15' C/C)
13	12" WHITE GORE MARKING (10' C/C)
⊗	REMOVE SIGN (SEE SUMMARY OF SIGN REMOVALS)

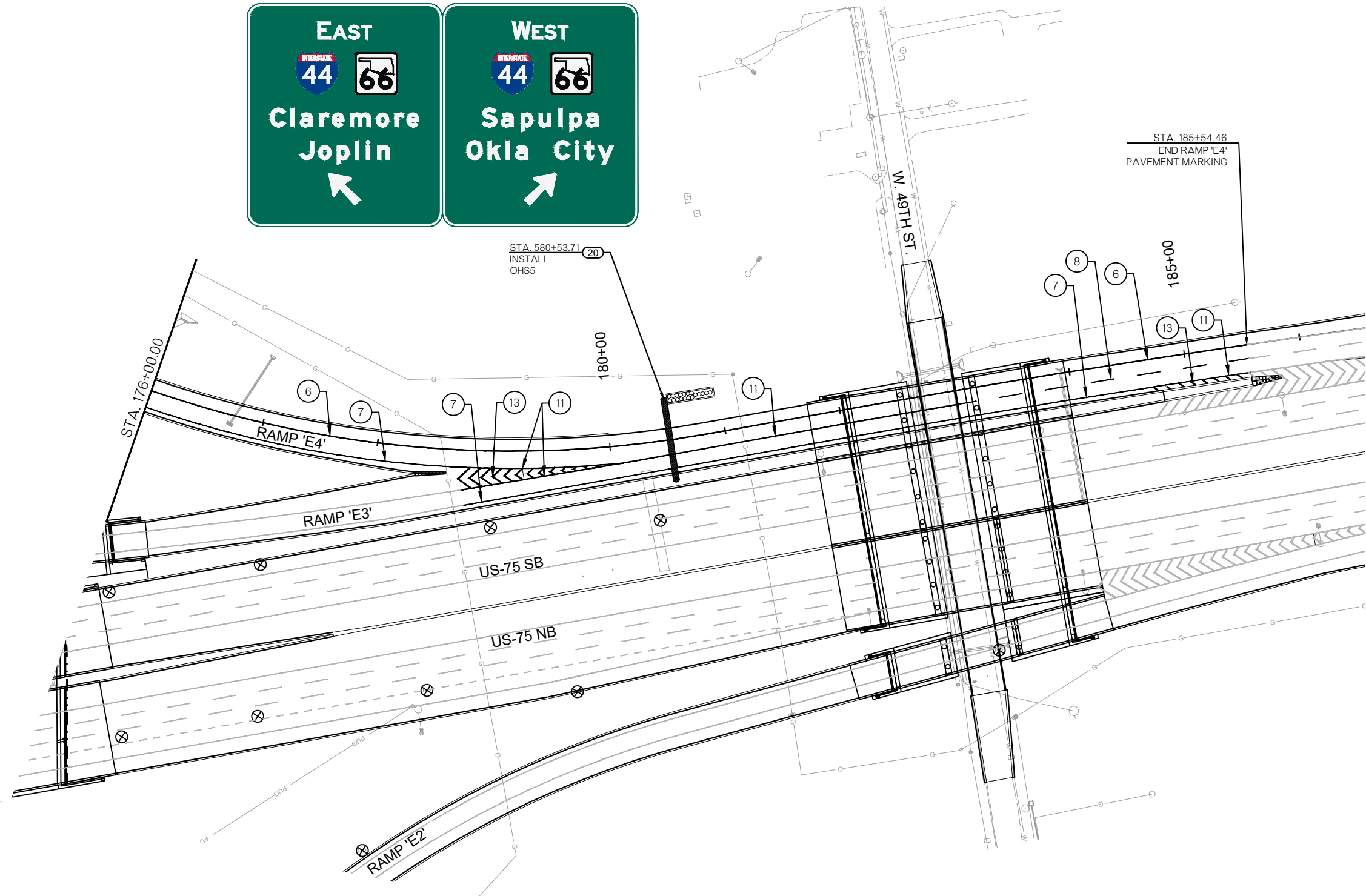

SEC. 26
T-19-N, R-12-E

DESIGN	REH	3/2021	OKLAHOMA DEPARTMENT OF TRANSPORTATION
DRAWN	JMJ	3/2021	
CHECKED	JRW	3/2021	
APPROVED	EMS	3/2021	
SQUAD	LEE		
SIGNING & MARKING PLAN			RAMP 'E4' CRL - SHEET 2 OF 2 STA. 176+00 TO STA. 185+54
COUNTY	TULSA	HIGHWAY US-75 STATE JOB NO. 33788(11) SHEET NO. T011	

SEC. 35
T-19-N, R-12-E

R/W UTILITY
MEETING

MARCH 2021

LEGEND

- ① 4" SOLID WHITE LINE
- ② 4" SOLID YELLOW LINE
- ③ 4" DOUBLE YELLOW BARRIER LINE
- ④ 4" DASHED WHITE LINE
- ⑤ 4" DASHED YELLOW LINE
- ⑥ 6" SOLID WHITE EDGE LINE
- ⑦ 6" SOLID YELLOW EDGE LINE
- ⑧ 6" DASHED LANE LINE (WHITE/BLACK)
- ⑨ 6" DOTTED LANE LINE (WHITE/BLACK)
- ⑩ 8" DOTTED LANE LINE (WHITE/BLACK)
- ⑪ 8" SOLID WHITE LINE
- ⑫ 8" YELLOW GORE MARKING (15' C/C)
- ⑬ 12" WHITE GORE MARKING (10' C/C)
- ⊗ REMOVE SIGN (SEE SUMMARY OF SIGN REMOVALS)

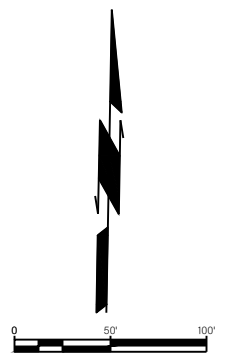
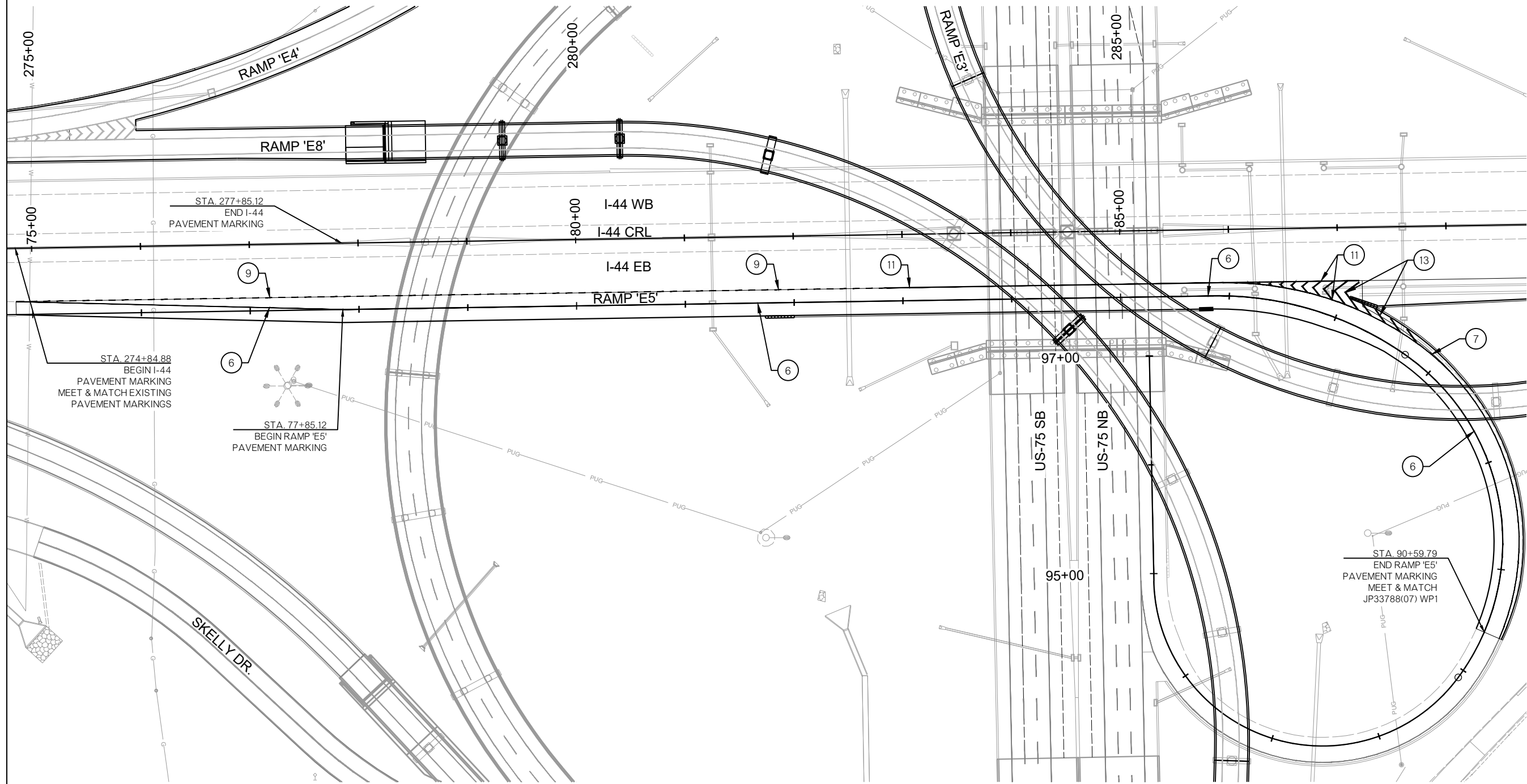

SEC. 35
T-19-N, R-12-E

DESIGN	REH	3/2021	OKLAHOMA DEPARTMENT OF TRANSPORTATION
DRAWN	JMJ	3/2021	
CHECKED	JRW	3/2021	
APPROVED	EMS	3/2021	
SQUAD	LEE		
COUNTY TULSA HIGHWAY US-75 STATE JOB NO. 33788(11) SHEET NO. T012			

SIGNING & MARKING PLAN
RAMP 'E5' CRL - SHEET 1 OF 1
STA. 77+85 TO STA. 90+60

2/26/2021

SEC. 35
T-19-N, R-12-E

R/W UTILITY
MEETING

MARCH 2021

LEGEND

1	4" SOLID WHITE LINE
2	4" SOLID YELLOW LINE
3	4" DOUBLE YELLOW BARRIER LINE
4	4" DASHED WHITE LINE
5	4" DASHED YELLOW LINE
6	6" SOLID WHITE EDGE LINE
7	6" SOLID YELLOW EDGE LINE
8	6" DASHED LANE LINE (WHITE/BLACK)
9	6" DOTTED LANE LINE (WHITE/BLACK)
10	8" DOTTED LANE LINE (WHITE/BLACK)
11	8" SOLID WHITE LINE
12	8" YELLOW GORE MARKING (15' C/C)
13	12" WHITE GORE MARKING (10' C/C)
⊗	REMOVE SIGN (SEE SUMMARY OF SIGN REMOVALS)

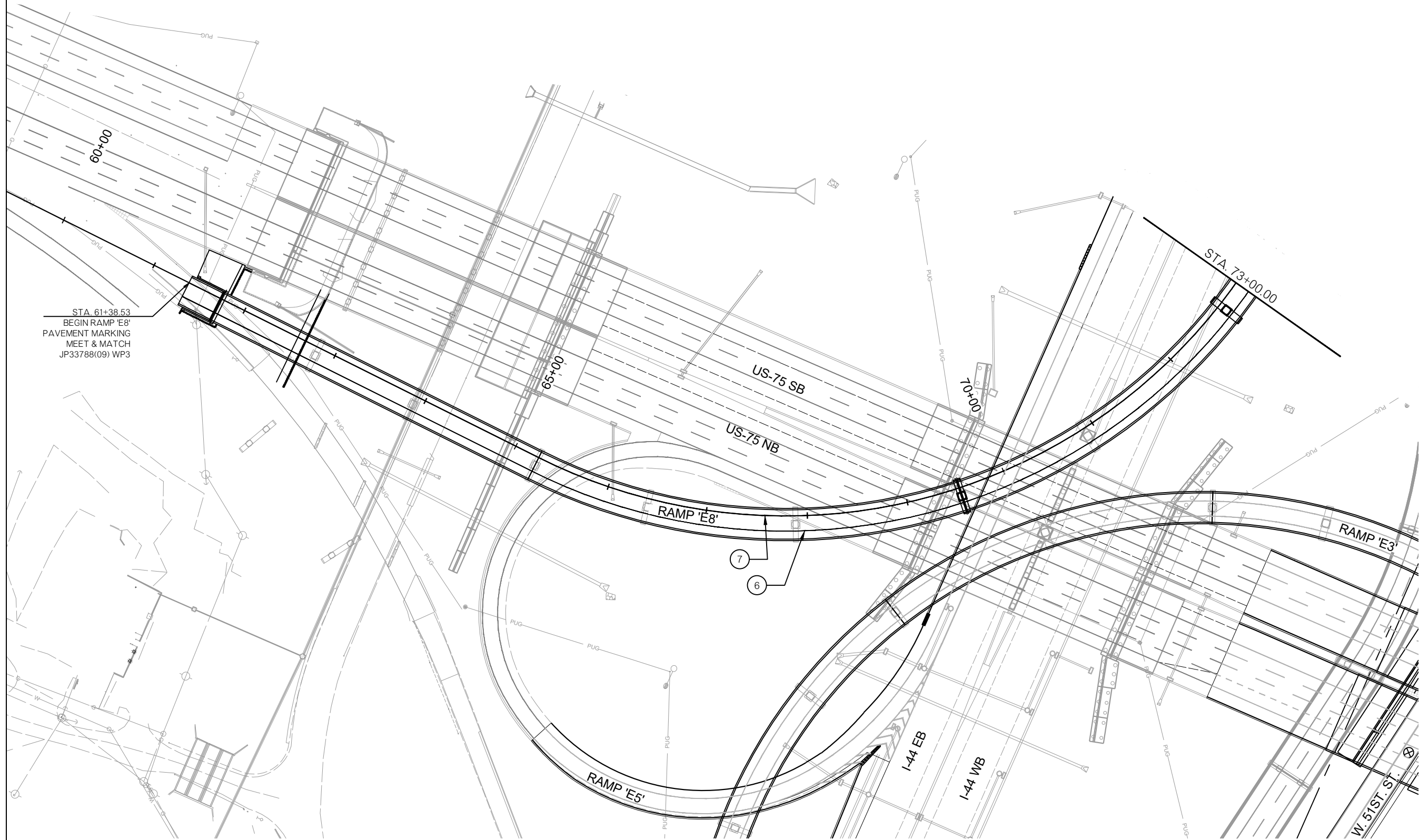

STA 61+38.53
BEGIN RAMP 'E8'
PAVEMENT MARKING
MEET & MATCH
JP33788(09) WP3

SEC. 26
T-19-N, R-12-E

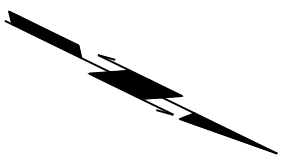

SEC. 35
T-19-N, R-12-E

DESIGN	REH	3/2021	OKLAHOMA DEPARTMENT OF TRANSPORTATION
DRAWN	JMJ	3/2021	
CHECKED	JRW	3/2021	
APPROVED	EMS	3/2021	
SQUAD	LEE		
COUNTY TULSA HIGHWAY US-75 STATE JOB NO. 33788(11) SHEET NO. T013			

SIGNING & MARKING PLAN
RAMP 'E8' CRL - SHEET 1 OF 2
STA. 61+39 TO STA. 73+00

JP33788(09) - SS - WP5.dwg

2/26/2021

SEC. 35
T-19-N, R-12-E

SEC. 34
T-19-N, R-12-E

LEGEND

1	4" SOLID WHITE LINE
2	4" SOLID YELLOW LINE
3	4" DOUBLE YELLOW BARRIER LINE
4	4" DASHED WHITE LINE
5	4" DASHED YELLOW LINE
6	6" SOLID WHITE EDGE LINE
7	6" SOLID YELLOW EDGE LINE
8	6" DASHED LANE LINE (WHITE/BLACK)
9	6" DOTTED LANE LINE (WHITE/BLACK)
10	8" DOTTED LANE LINE (WHITE/BLACK)
11	8" SOLID WHITE LINE
12	8" YELLOW GORE MARKING (15' C/C)
13	12" WHITE GORE MARKING (10' C/C)
⊗	REMOVE SIGN (SEE SUMMARY OF SIGN REMOVALS)

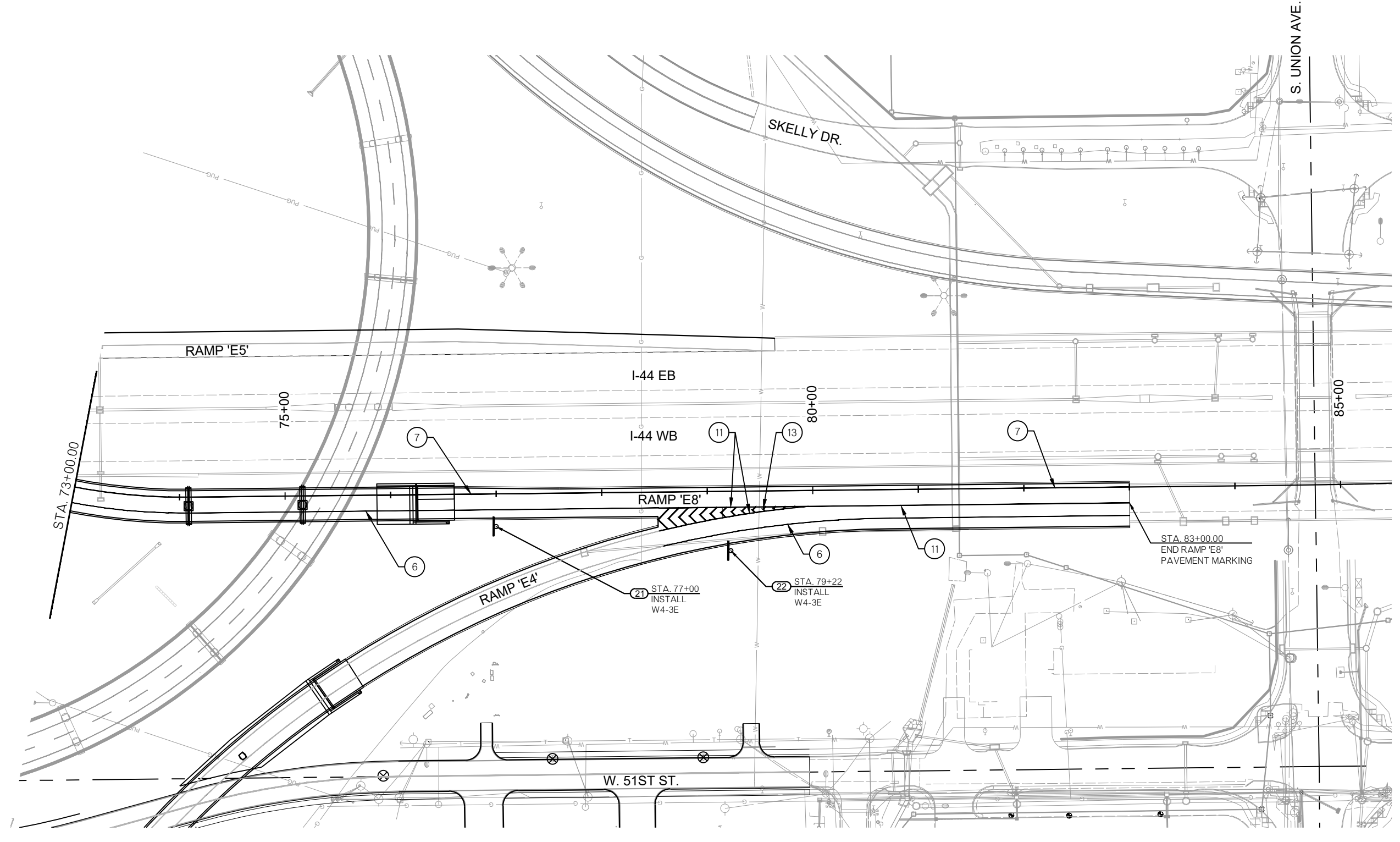

SEC. 27
T-19-N, R-12-E

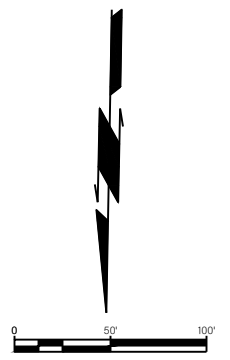

SEC. 26
T-19-N, R-12-E

DESIGN	REH	3/2021	OKLAHOMA DEPARTMENT OF TRANSPORTATION
DRAWN	JMJ	3/2021	
CHECKED	JRW	3/2021	
APPROVED	EMS	3/2021	
SQUAD	LEE		
SIGNING & MARKING PLAN			RAMP 'E8' CRL - SHEET 2 OF 2 STA. 73+00 TO STA. 83+00
COUNTY TULSA HIGHWAY US-75 STATE JOB NO. 33788(11) SHEET NO. T014			

J:\3378808 - SS - WP5.dwg

2/26/2021

SEC. 26
T-19-N, R-12-E

R/W UTILITY
MEETING

MARCH 2021

LEGEND

- ① 4" SOLID WHITE LINE
- ② 4" SOLID YELLOW LINE
- ③ 4" DOUBLE YELLOW BARRIER LINE
- ④ 4" DASHED WHITE LINE
- ⑤ 4" DASHED YELLOW LINE
- ⑥ 6" SOLID WHITE EDGE LINE
- ⑦ 6" SOLID YELLOW EDGE LINE
- ⑧ 6" DASHED LANE LINE (WHITE/BLACK)
- ⑨ 6" DOTTED LANE LINE (WHITE/BLACK)
- ⑩ 8" DOTTED LANE LINE (WHITE/BLACK)
- ⑪ 8" SOLID WHITE LINE
- ⑫ 8" YELLOW GORE MARKING (15' C/C)
- ⑬ 12" WHITE GORE MARKING (10' C/C)
- ⊗ REMOVE SIGN (SEE SUMMARY OF SIGN REMOVALS)

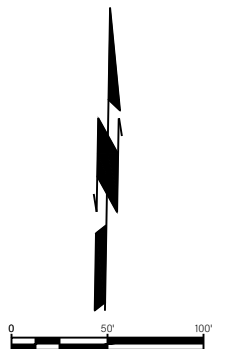
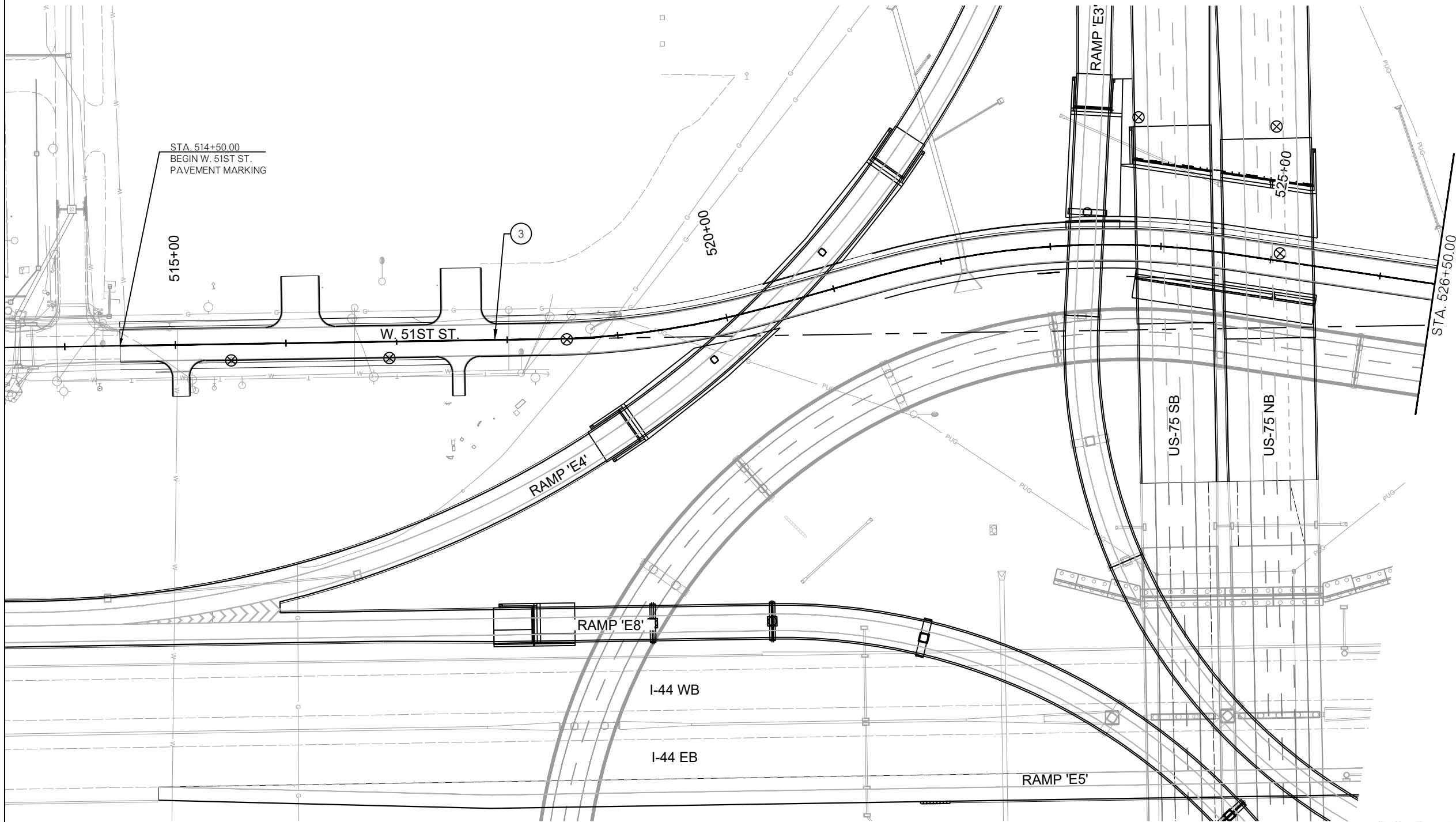

SEC. 35
T-19-N, R-12-E

DESIGN	REH	3/2021	OKLAHOMA DEPARTMENT OF TRANSPORTATION
DRAWN	JMJ	3/2021	
CHECKED	JRW	3/2021	
APPROVED	EMS	3/2021	
SQUAD	LEE		
SIGNING & MARKING PLAN			SHEET NO. T015
W. 51ST ST. CR. - SHEET 1 OF 3			
STA. 514+50 TO STA. 526+50			
COUNTY	TULSA	HIGHWAY	US-75 STATE JOB NO. 33788(11)

J:\3378808 - SS - WP5.dwg

SEC. 26
T-19-N, R-12-E

R/W UTILITY MEETING
MARCH 2021

LEGEND

1	4" SOLID WHITE LINE
2	4" SOLID YELLOW LINE
3	4" DOUBLE YELLOW BARRIER LINE
4	4" DASHED WHITE LINE
5	4" DASHED YELLOW LINE
6	6" SOLID WHITE EDGE LINE
7	6" SOLID YELLOW EDGE LINE
8	6" DASHED LANE LINE (WHITE/BLACK)
9	6" DOTTED LANE LINE (WHITE/BLACK)
10	8" DOTTED LANE LINE (WHITE/BLACK)
11	8" SOLID WHITE LINE
12	8" YELLOW GORE MARKING (15' C/C)
13	12" WHITE GORE MARKING (10' C/C)
⊗	REMOVE SIGN (SEE SUMMARY OF SIGN REMOVALS)

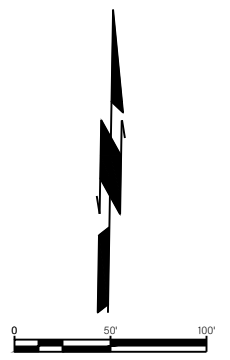
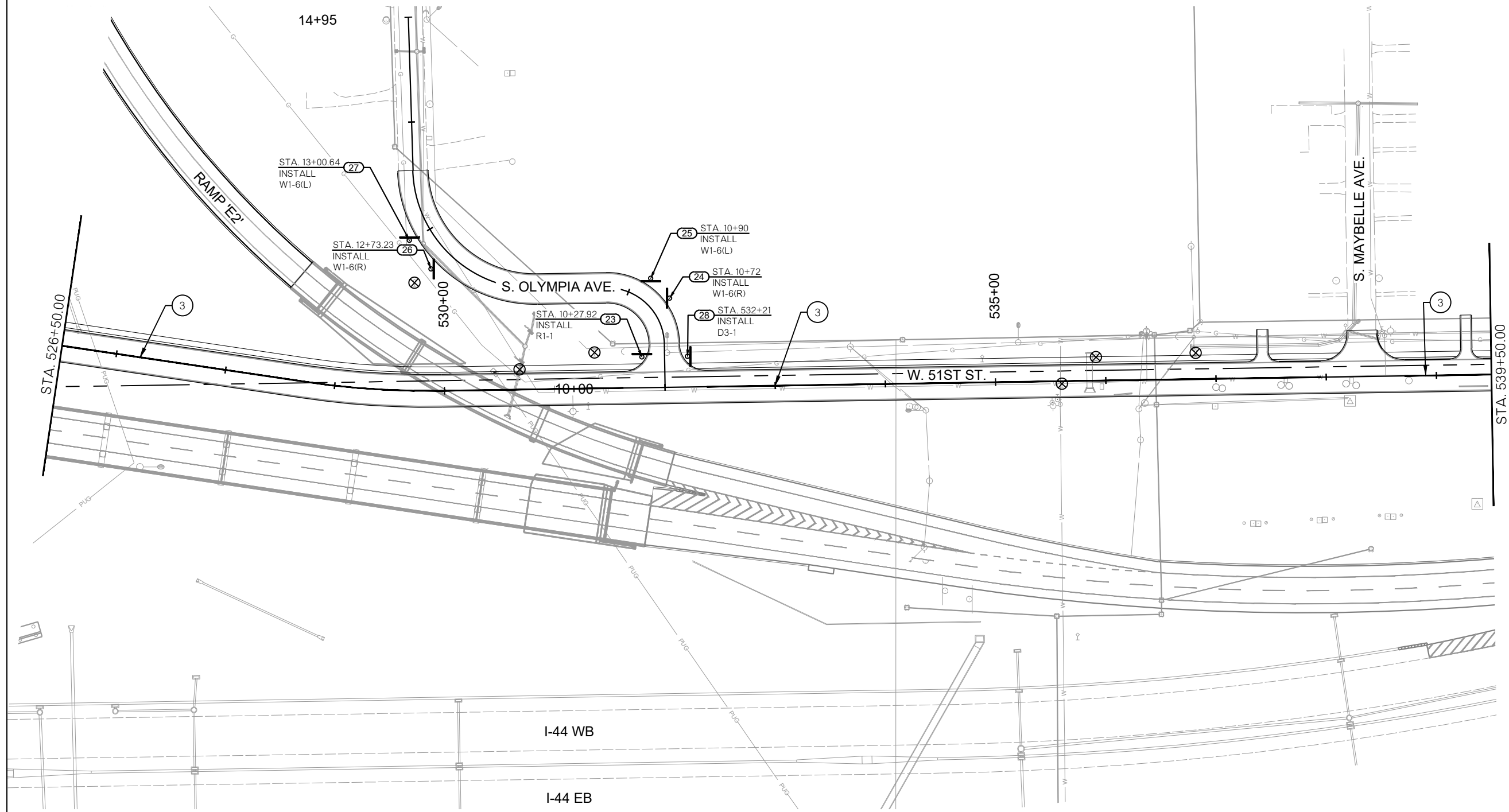

SEC. 35
T-19-N, R-12-E

DESIGN	REH	3/2021	OKLAHOMA DEPARTMENT OF TRANSPORTATION		
DRAWN	JMJ	3/2021			
CHECKED	JRW	3/2021			
APPROVED	EMS	3/2021			
SQUAD	LEE				
SIGNING & MARKING PLAN			SHEET NO. T016		
W. 51ST ST. CRL - SHEET 2 OF 3					
STA. 526+50 TO STA. 539+50					
COUNTY	TULSA	HIGHWAY	US-75	STATE JOB NO.	33788(11)

LEGEND

- ① 4" SOLID WHITE LINE
- ② 4" SOLID YELLOW LINE
- ③ 4" DOUBLE YELLOW BARRIER LINE
- ④ 4" DASHED WHITE LINE
- ⑤ 4" DASHED YELLOW LINE
- ⑥ 6" SOLID WHITE EDGE LINE
- ⑦ 6" SOLID YELLOW EDGE LINE
- ⑧ 6" DASHED LANE LINE (WHITE/BLACK)
- ⑨ 6" DOTTED LANE LINE (WHITE/BLACK)
- ⑩ 8" DOTTED LANE LINE (WHITE/BLACK)
- ⑪ 8" SOLID WHITE LINE
- ⑫ 8" YELLOW GORE MARKING (15' C/C)
- ⑬ 12" WHITE GORE MARKING (10' C/C)
- ⊗ REMOVE SIGN (SEE SUMMARY OF SIGN REMOVALS)

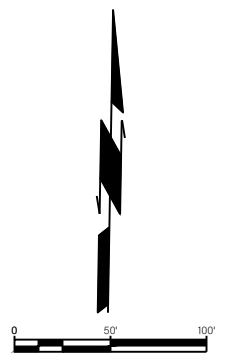
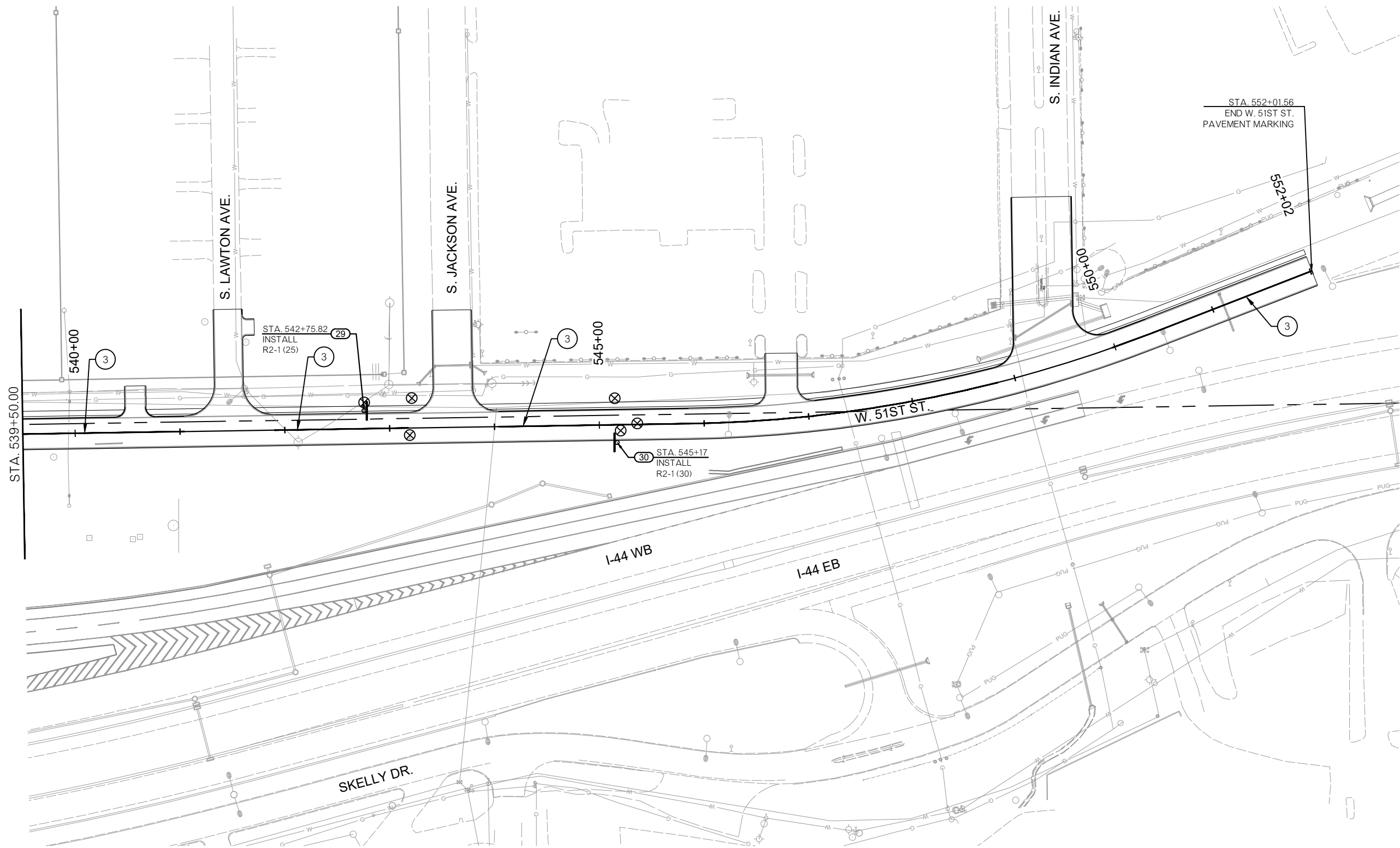

DESIGN	REH	3/2021	OKLAHOMA DEPARTMENT OF TRANSPORTATION
DRAWN	JMJ	3/2021	
CHECKED	JRW	3/2021	
APPROVED	EMS	3/2021	
SQUAD	LEE		
SIGNING & MARKING PLAN			
W. 51ST ST. CRL - SHEET 3 OF 3			
STA. 539+50 TO STA. 552+01.56			
COUNTY	TULSA	HIGHWAY	US-75 STATE JOB NO. 33788(11) SHEET NO. T017

SEC. 26
T-19-N, R-12-E

NOTES:

1. ALL CONDUIT SHALL BE 2" PVC SCHEDULE 40 UNLESS OTHERWISE NOTED. SEE ODOT STD. CCD1-1-(LATEST REVISION) FOR DETAILS.
2. SERVICE POLE LOCATIONS SHOWN IN THE PLANS MUST BE APPROVED BY THE ENGINEER PRIOR TO INSTALLATION. THE PROPOSED SERVICE POLES SHALL BE CONNECTED TO EXISTING PSO POWER SERVICE. CONTRACTOR SHALL COORDINATE WITH POWER COMPANY PRIOR TO LOCATING OR INSTALLING SERVICE POLES IN THE FIELD. SEE ODOT STD. SPD1-1-(LATEST REVISION), SCD1-1-(LATEST REVISION), AND TEWD1-1-(LATEST REVISION).
3. PROVIDE 30' MINIMUM DISTANCE FROM SIGN STRUCTURES.

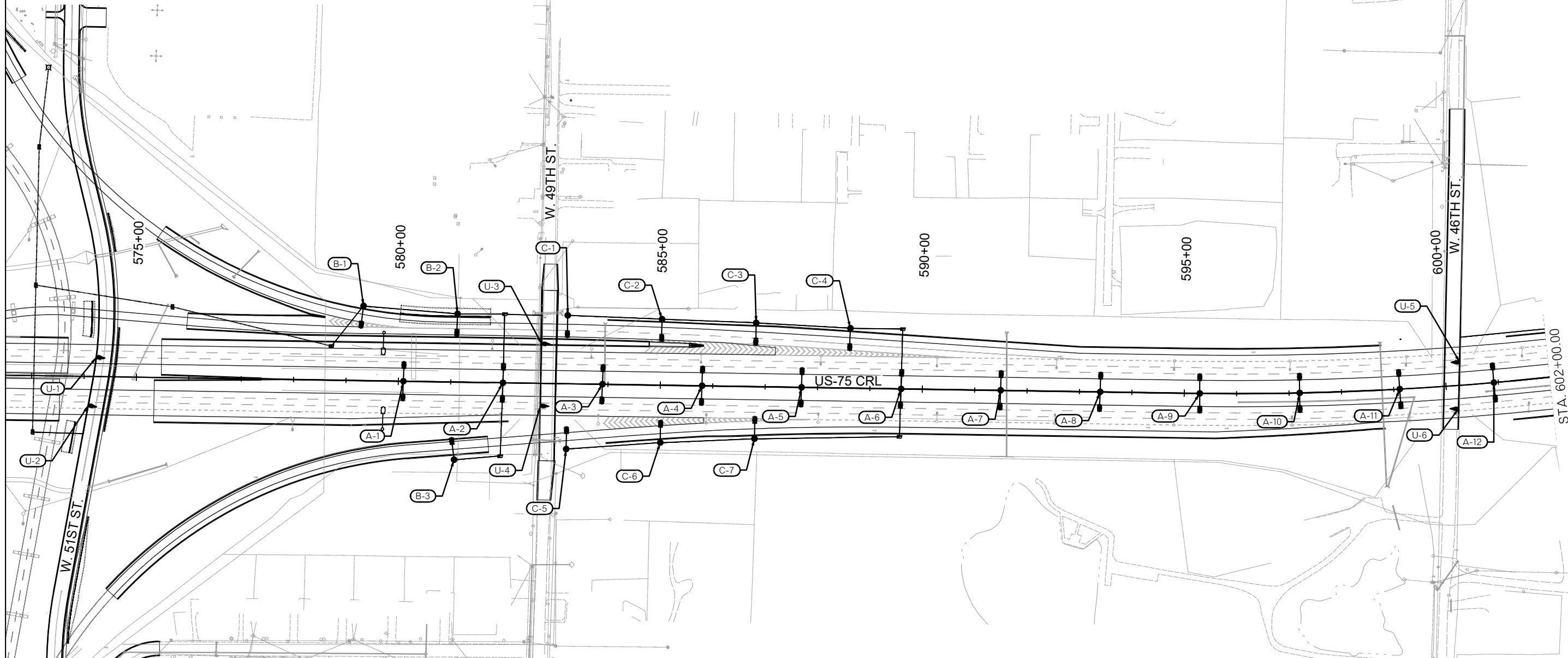

LEGEND

- PROPOSED 40' MH ROADWAY LIGHT (DOUBLE)
- PROPOSED 40' MH ROADWAY LIGHT (SINGLE)
- PUG — PROPOSED UNDERGROUND CONDUIT
- ⊗ CIRCUIT ID
- EXISTING ROADWAY LIGHT
- POWER SERVICE TRANSFORMER
- ⊗ SERVICE POLE
- PULL BOX (SIZE II)
- EXISTING PULL BOX
- (A-1) LIGHT POLE ID NUMBER

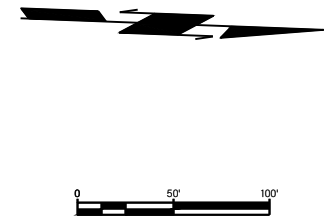

SEC. 26
T-19-N, R-12-E

DESIGN	REH	3/2021	OKLAHOMA DEPARTMENT OF TRANSPORTATION
DRAWN	JMJ	3/2021	
CHECKED	JRW	3/2021	
APPROVED	EMS	3/2021	
SQUAD	LEE		
COUNTY	TULSA		

LIGHTING PLAN
US-75 CRL - SHEET 1 OF 2
STA. 575+00 TO STA. 602+00

HIGHWAY US-75 STATE JOB NO. 33788(11) SHEET NO. T018

2/26/2021
JP3378808 - LIGHTING SHEETS - WPS.dwg

SEC. 26
T-19-N, R-12-E

NOTES:

1. ALL CONDUIT SHALL BE 2" PVC SCHEDULE 40 UNLESS OTHERWISE NOTED. SEE ODOT STD. CCD1-1-(LATEST REVISION) FOR DETAILS.
2. SERVICE POLE LOCATIONS SHOWN IN THE PLANS MUST BE APPROVED BY THE ENGINEER PRIOR TO INSTALLATION. THE PROPOSED SERVICE POLES SHALL BE CONNECTED TO EXISTING PSO POWER SERVICE. CONTRACTOR SHALL COORDINATE WITH POWER COMPANY PRIOR TO LOCATING OR INSTALLING SERVICE POLES IN THE FIELD. SEE ODOT STD. SPD1-1-(LATEST REVISION), SCD1-1-(LATEST REVISION), AND TEWD1-1-(LATEST REVISION).
3. PROVIDE 30' MINIMUM DISTANCE FROM SIGN STRUCTURES.

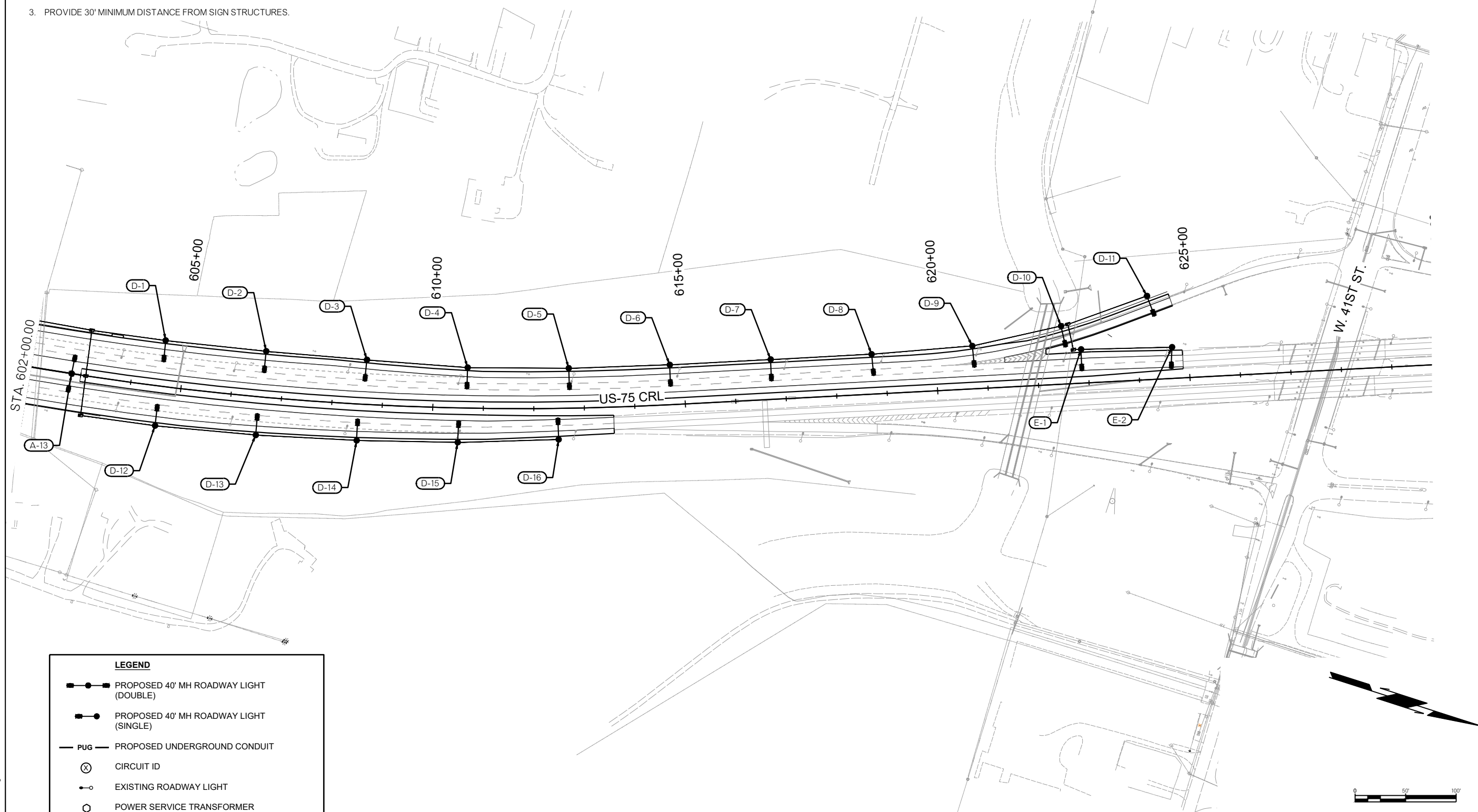

LEGEND

- PROPOSED 40' MH ROADWAY LIGHT (DOUBLE)
- PROPOSED 40' MH ROADWAY LIGHT (SINGLE)
- PUG — PROPOSED UNDERGROUND CONDUIT
- ⊗ CIRCUIT ID
- EXISTING ROADWAY LIGHT
- POWER SERVICE TRANSFORMER
- ⊗ SERVICE POLE
- PULL BOX (SIZE II)
- EXISTING PULL BOX
- (A-1) LIGHT POLE ID NUMBER

SEC. 26
T-19-N, R-12-E

DESIGN	REH	3/2021	OKLAHOMA DEPARTMENT OF TRANSPORTATION
DRAWN	JMJ	3/2021	
CHECKED	JRW	3/2021	
APPROVED	EMS	3/2021	
SQUAD	LEE		
COUNTY	TULSA		

LIGHTING PLAN
US-75 CRL - SHEET 2 OF 2
STA. 602+00 TO STA. 629+00

HIGHWAY US-75 STATE JOB NO. 33788(11) SHEET NO. T019

2/26/2021 JP3378808 - LIGHTING SHEETS - WPS.dwg

SEE SHEET T021
MATCHLINE STA. 585+00

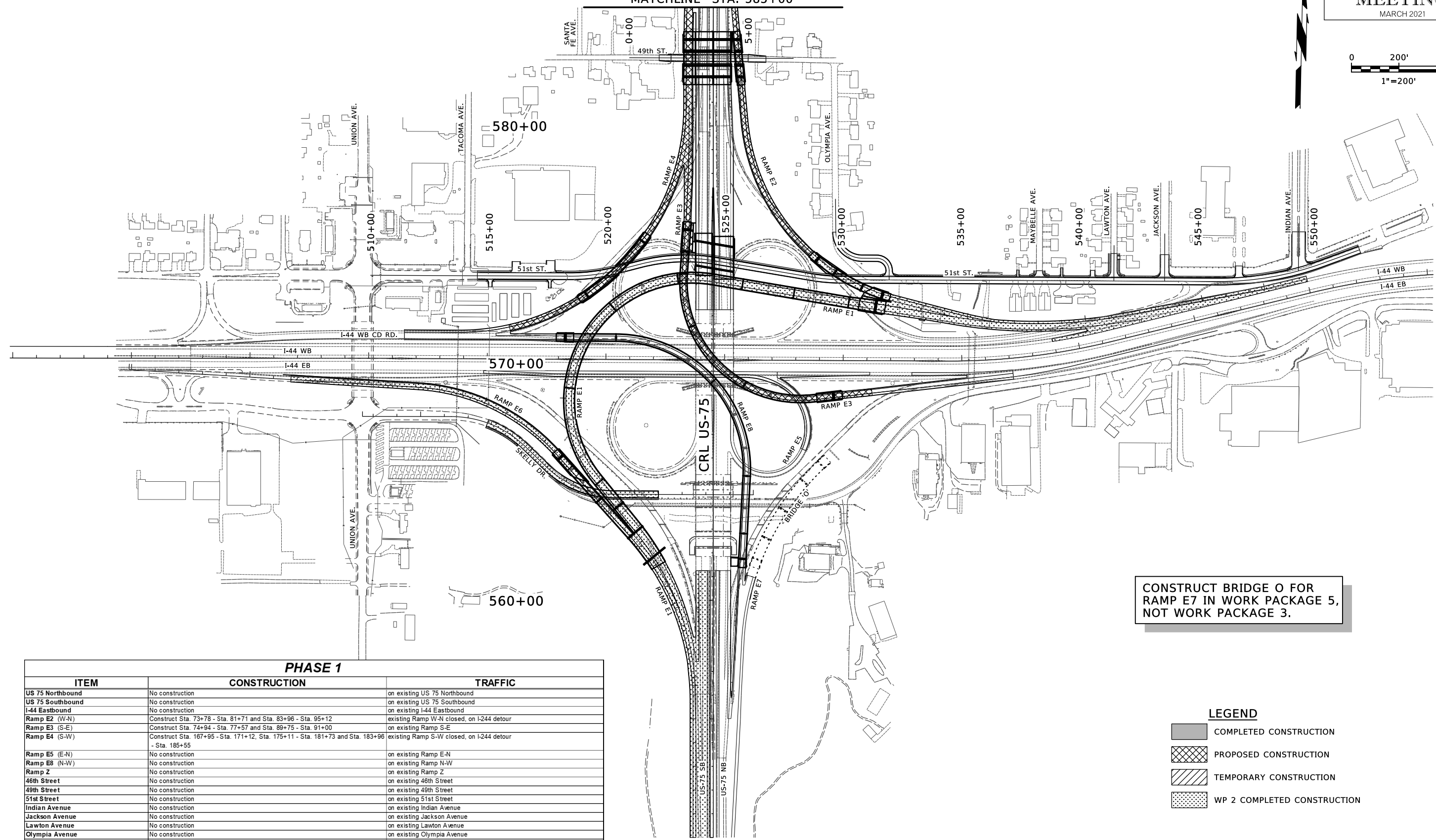
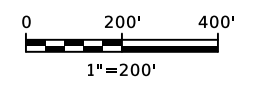

CONSTRUCT BRIDGE O FOR RAMP E7 IN WORK PACKAGE 5, NOT WORK PACKAGE 3.

PHASE 1		
ITEM	CONSTRUCTION	TRAFFIC
US 75 Northbound	No construction	on existing US 75 Northbound
US 75 Southbound	No construction	on existing US 75 Southbound
I-44 Eastbound	No construction	on existing I-44 Eastbound
Ramp E2 (W-N)	Construct Sta. 73+78 - Sta. 81+71 and Sta. 83+96 - Sta. 95+12	existing Ramp W-N closed, on I-244 detour
Ramp E3 (S-E)	Construct Sta. 74+94 - Sta. 77+57 and Sta. 89+75 - Sta. 91+00	on existing Ramp S-E
Ramp E4 (S-W)	Construct Sta. 167+95 - Sta. 171+12, Sta. 175+11 - Sta. 181+73 and Sta. 183+96 - Sta. 185+55	existing Ramp S-W closed, on I-244 detour
Ramp E5 (E-N)	No construction	on existing Ramp E-N
Ramp E8 (N-W)	No construction	on existing Ramp N-W
Ramp Z	No construction	on existing Ramp Z
46th Street	No construction	on existing 46th Street
49th Street	No construction	on existing 49th Street
51st Street	No construction	on existing 51st Street
Indian Avenue	No construction	on existing Indian Avenue
Jackson Avenue	No construction	on existing Jackson Avenue
Lawton Avenue	No construction	on existing Lawton Avenue
Olympia Avenue	No construction	on existing Olympia Avenue
Bridge F1 (US 75 Northbound)	No construction	on existing US 75 Northbound
Bridge F2 (US 75 Southbound)	No construction	on existing US 75 Southbound
Bridge G1 (US 75 Northbound)	No construction	on existing US 75 Northbound
Bridge G2 (US 75 Southbound)	No construction	on existing US 75 Southbound
Bridge J1 (US 75 Northbound)	No construction	on existing US 75 Northbound
Bridge J2 (US 75 SB & Ramp E4 / E3)	Construct west portion (for Ramp E4 / E3)	on existing US 75 Southbound
Bridge J3 (Ramp E2)	Construct	existing Ramp W-N closed, on I-244 detour
Bridge L (Ramp E3)	Construct	on existing Ramp S-E
Bridge M (Ramp E4)	Construct	existing Ramp S-W closed, on I-244 detour
Bridge P (Ramp E8)	No construction	on existing Ramp N-W

LEGEND

	COMPLETED CONSTRUCTION
	PROPOSED CONSTRUCTION
	TEMPORARY CONSTRUCTION
	WP 2 COMPLETED CONSTRUCTION



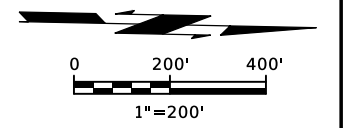

PHASE 1

DESIGN		OKLAHOMA DEPARTMENT OF TRANSPORTATION
DRAWN		
CHECKED		
APPROVED		
SQUAD		
SUGGESTED CONSTRUCTION SEQUENCE (1)		
COUNTY - TULSA	HIGHWAY US-75	STATE JOB NO. 33788(11) SHEET NO. T020



SEE SHEET T020
MATCHLINE STA. 585+00

LEGEND

	COMPLETED CONSTRUCTION
	PROPOSED CONSTRUCTION
	TEMPORARY CONSTRUCTION
	WP 2 COMPLETED CONSTRUCTION

PHASE 1

DESIGN		OKLAHOMA DEPARTMENT OF TRANSPORTATION
DRAWN		
CHECKED		
APPROVED		
SQUAD		
SUGGESTED CONSTRUCTION SEQUENCE (2)		
COUNTY	TULSA	HIGHWAY US-75 STATE JOB NO. 33788(11) SHEET NO. T021

SEE SHEET T023
MATCHLINE STA. 585+00

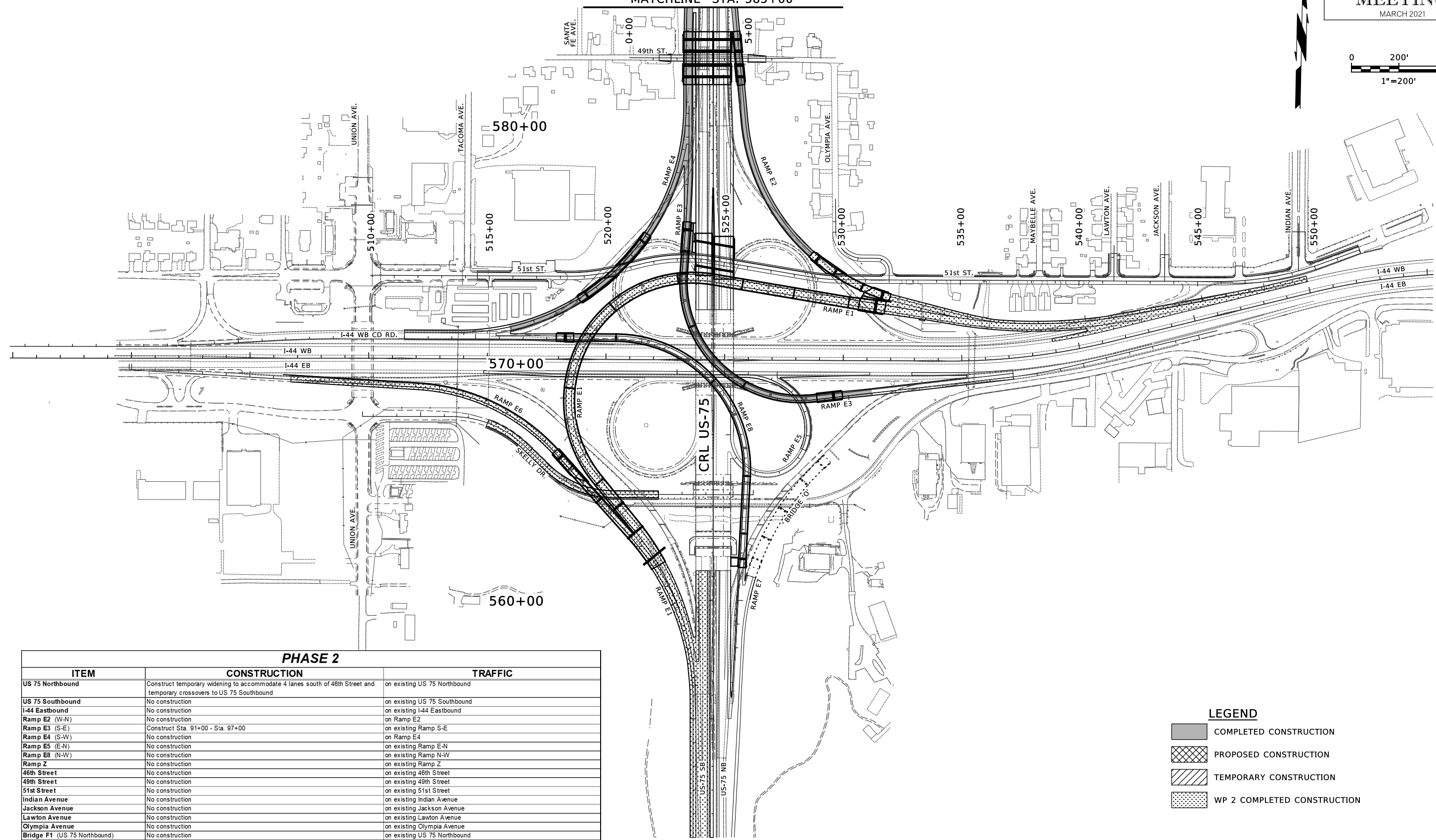
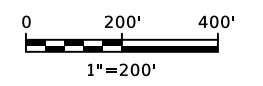

PHASE 2		
ITEM	CONSTRUCTION	TRAFFIC
US 75 Northbound	Construct temporary widening to accommodate 4 lanes south of 46th Street and temporary crossovers to US 75 Southbound	on existing US 75 Northbound
US 75 Southbound	No construction	on existing US 75 Southbound
I-44 Eastbound	No construction	on existing I-44 Eastbound
Ramp E2 (W-N)	No construction	on Ramp E2
Ramp E3 (S-E)	Construct Sta. 91+00 - Sta. 97+00	on existing Ramp S-E
Ramp E4 (S-W)	No construction	on Ramp E4
Ramp E5 (E-N)	No construction	on existing Ramp E-N
Ramp E8 (N-W)	No construction	on existing Ramp N-W
Ramp Z	No construction	on existing Ramp Z
46th Street	No construction	on existing 46th Street
49th Street	No construction	on existing 49th Street
51st Street	No construction	on existing 51st Street
Indian Avenue	No construction	on existing Indian Avenue
Jackson Avenue	No construction	on existing Jackson Avenue
Lawton Avenue	No construction	on existing Lawton Avenue
Olympia Avenue	No construction	on existing Olympia Avenue
Bridge F1 (US 75 Northbound)	No construction	on existing US 75 Northbound
Bridge F2 (US 75 Southbound)	No construction	on existing US 75 Southbound
Bridge G1 (US 75 Northbound)	No construction	on existing US 75 Northbound
Bridge G2 (US 75 Southbound)	No construction	on existing US 75 Southbound
Bridge J1 (US 75 Northbound)	No construction	on existing US 75 Northbound
Bridge J2 (US 75 NB & Ramp E4 / E3)	No construction	on existing US 75 Southbound
Bridge J3 (Ramp E2)	No construction	on Ramp E2
Bridge L (Ramp E3)	No construction	on existing Ramp S-E
Bridge M (Ramp E4)	No construction	on Ramp E4
Bridge P (Ramp E8)	No construction	on existing Ramp N-W



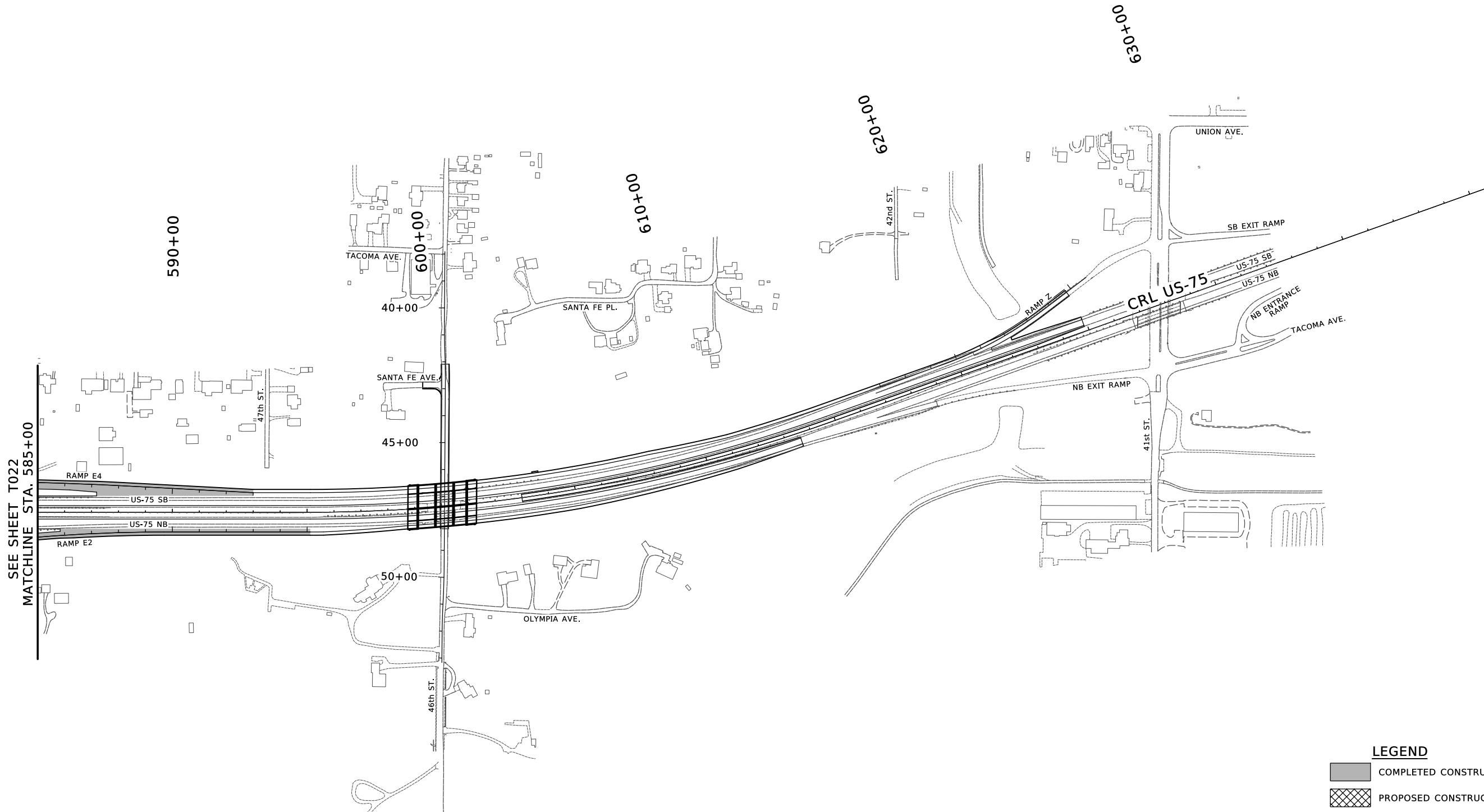
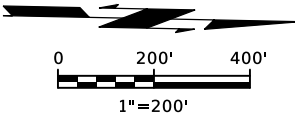

LEGEND

	COMPLETED CONSTRUCTION
	PROPOSED CONSTRUCTION
	TEMPORARY CONSTRUCTION
	WP 2 COMPLETED CONSTRUCTION

PHASE 2		OKLAHOMA DEPARTMENT OF TRANSPORTATION
DESIGN		
DRAWN		
CHECKED		
APPROVED		
SQUAD		
SUGGESTED CONSTRUCTION SEQUENCE (3)		
COUNTY - TULSA	HIGHWAY US-75	STATE JOB NO. 33788(11) SHEET NO. T022



LEGEND

	COMPLETED CONSTRUCTION
	PROPOSED CONSTRUCTION
	TEMPORARY CONSTRUCTION
	WP 2 COMPLETED CONSTRUCTION

PHASE 2

DESIGN		OKLAHOMA DEPARTMENT OF TRANSPORTATION
DRAWN		
CHECKED		
APPROVED		
SQUAD		
SUGGESTED CONSTRUCTION SEQUENCE (4)		
COUNTY	TULSA	HIGHWAY US-75 STATE JOB NO. 33788(11) SHEET NO. T023

SEE SHEET T025
MATCHLINE STA. 585+00

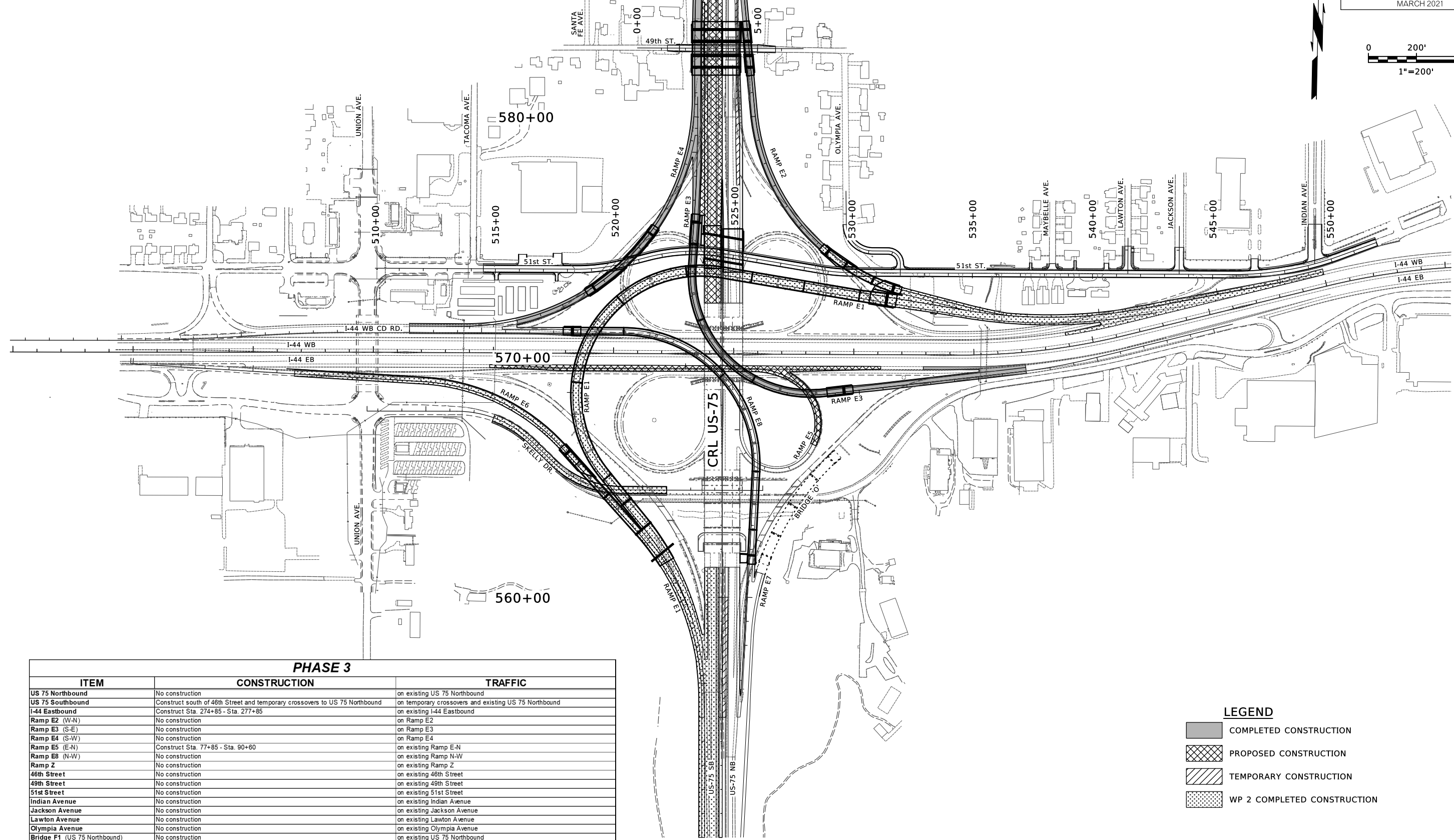
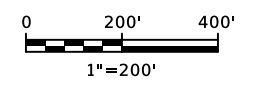

PHASE 3		
ITEM	CONSTRUCTION	TRAFFIC
US 75 Northbound	No construction	on existing US 75 Northbound
US 75 Southbound	Construct south of 46th Street and temporary crossovers to US 75 Northbound	on temporary crossovers and existing US 75 Northbound
I-44 Eastbound	Construct Sta. 274+85 - Sta. 277+85	on existing I-44 Eastbound
Ramp E2 (W-N)	No construction	on Ramp E2
Ramp E3 (S-E)	No construction	on Ramp E3
Ramp E4 (S-W)	No construction	on Ramp E4
Ramp E5 (E-N)	Construct Sta. 77+85 - Sta. 90+60	on existing Ramp E-N
Ramp E8 (N-W)	No construction	on existing Ramp N-W
Ramp Z	No construction	on existing Ramp Z
46th Street	No construction	on existing 46th Street
49th Street	No construction	on existing 49th Street
51st Street	No construction	on existing 51st Street
Indian Avenue	No construction	on existing Indian Avenue
Jackson Avenue	No construction	on existing Jackson Avenue
Lawton Avenue	No construction	on existing Lawton Avenue
Olympia Avenue	No construction	on existing Olympia Avenue
Bridge F1 (US 75 Northbound)	No construction	on existing US 75 Northbound
Bridge F2 (US 75 Southbound)	Construct	on temporary crossovers and existing US 75 Northbound
Bridge G1 (US 75 Northbound)	No construction	on existing US 75 Northbound
Bridge G2 (US 75 Southbound)	No construction	on existing US 75 Southbound
Bridge J1 (US 75 Northbound)	No construction	on existing US 75 Northbound
Bridge J2 (US 75 SB & Ramp E4 / E3)	Construct east portion (for US 75 Southbound)	on temporary crossovers and existing US 75 Northbound
Bridge J3 (Ramp E2)	No construction	on Ramp E2
Bridge L (Ramp E3)	No construction	on Ramp E3
Bridge M (Ramp E4)	No construction	on Ramp E4
Bridge P (Ramp E8)	No construction	on existing Ramp N-W

LEGEND

	COMPLETED CONSTRUCTION
	PROPOSED CONSTRUCTION
	TEMPORARY CONSTRUCTION
	WP 2 COMPLETED CONSTRUCTION

PHASE 3		OKLAHOMA DEPARTMENT OF TRANSPORTATION
DESIGN		
DRAWN		
CHECKED		
APPROVED		
SQUAD		
SUGGESTED CONSTRUCTION SEQUENCE (5)		
COUNTY - TULSA	HIGHWAY US-75	STATE JOB NO. 33788(11) SHEET NO. T024



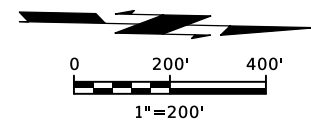

R/W UTILITY MEETING

MARCH 2021



SEE SHEET T024
MATCHLINE STA. 585+00

LEGEND

-  COMPLETED CONSTRUCTION
-  PROPOSED CONSTRUCTION
-  TEMPORARY CONSTRUCTION
-  WP 2 COMPLETED CONSTRUCTION

PHASE 3

DESIGN		OKLAHOMA DEPARTMENT OF TRANSPORTATION SUGGESTED CONSTRUCTION SEQUENCE (6)
DRAWN		
CHECKED		
APPROVED		
SQUAD		
COUNTY - TULSA		HIGHWAY US-75 STATE JOB NO. 33788(11) SHEET NO. T025

SEE SHEET T027
MATCHLINE STA. 585+00

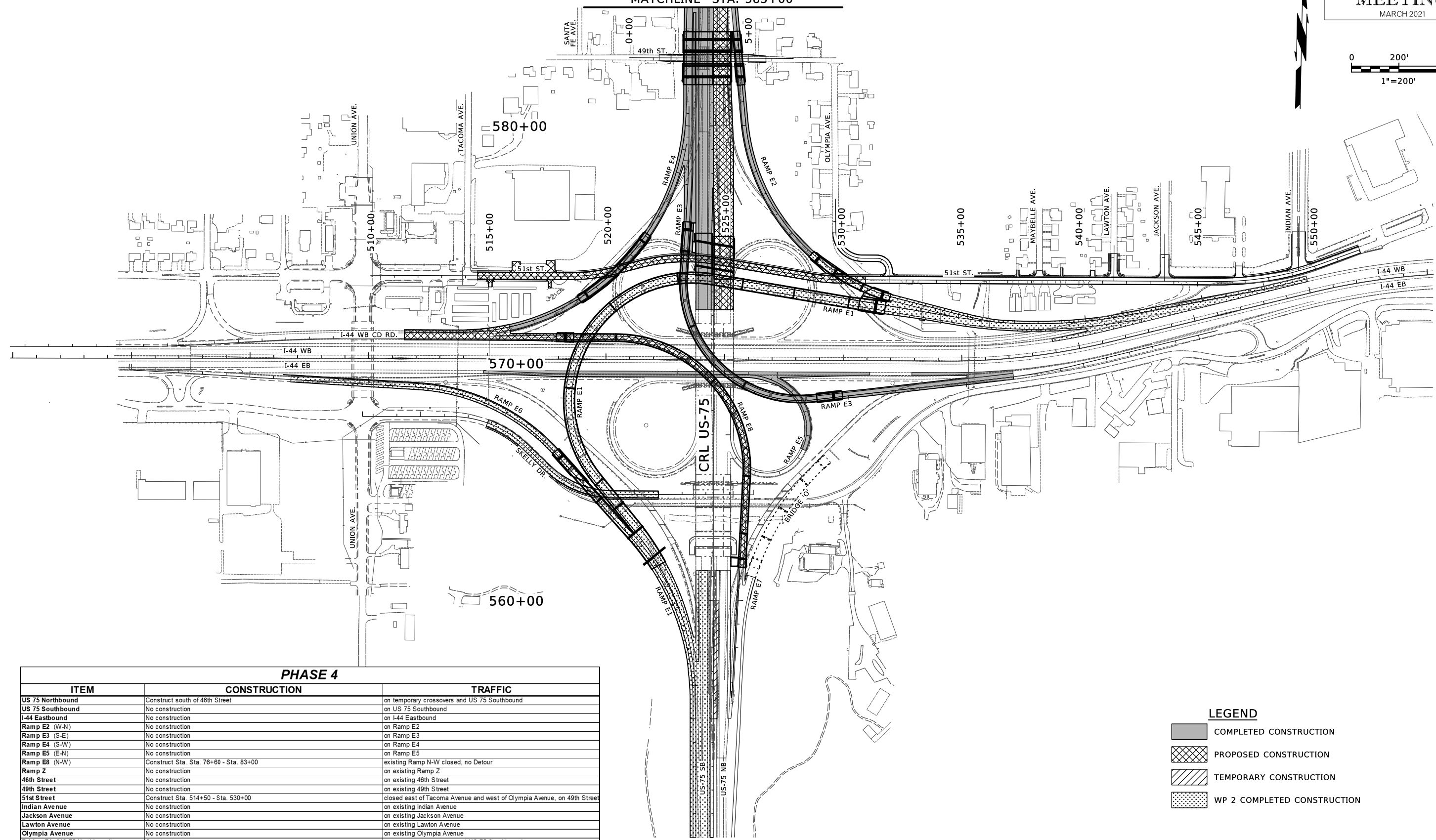
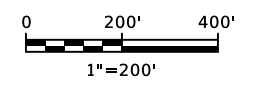

PHASE 4		
ITEM	CONSTRUCTION	TRAFFIC
US 75 Northbound	Construct south of 46th Street	on temporary crossovers and US 75 Southbound
US 75 Southbound	No construction	on US 75 Southbound
I-44 Eastbound	No construction	on I-44 Eastbound
Ramp E2 (W-N)	No construction	on Ramp E2
Ramp E3 (S-E)	No construction	on Ramp E3
Ramp E4 (S-W)	No construction	on Ramp E4
Ramp E5 (E-N)	No construction	on Ramp E5
Ramp E8 (N-W)	Construct Sta. 76+60 - Sta. 83+00	existing Ramp N-W closed, no Detour
Ramp Z	No construction	on existing Ramp Z
46th Street	No construction	on existing 46th Street
49th Street	No construction	on existing 49th Street
51st Street	Construct Sta. 514+50 - Sta. 530+00	closed east of Tacoma Avenue and west of Olympia Avenue, on 49th Street
Indian Avenue	No construction	on existing Indian Avenue
Jackson Avenue	No construction	on existing Jackson Avenue
Lawton Avenue	No construction	on existing Lawton Avenue
Olympia Avenue	No construction	on existing Olympia Avenue
Bridge F1 (US 75 Northbound)	Construct	on temporary crossovers and US 75 Southbound
Bridge F2 (US 75 Southbound)	No construction	on US 75 Southbound
Bridge G1 (US 75 Northbound)	No construction	on existing US 75 Northbound
Bridge G2 (US 75 Southbound)	No construction	on existing US 75 Southbound
Bridge J1 (US 75 Northbound)	Construct	on temporary crossovers and US 75 Southbound
Bridge J2 (US 75 SB & Ramp E4 / E3)	No construction	on US 75 Southbound
Bridge J3 (Ramp E2)	No construction	on Ramp E2
Bridge L (Ramp E3)	No construction	on Ramp E3
Bridge M (Ramp E4)	No construction	on Ramp E4
Bridge P (Ramp E8)	Construct	existing Ramp N-W closed, no Detour

LEGEND



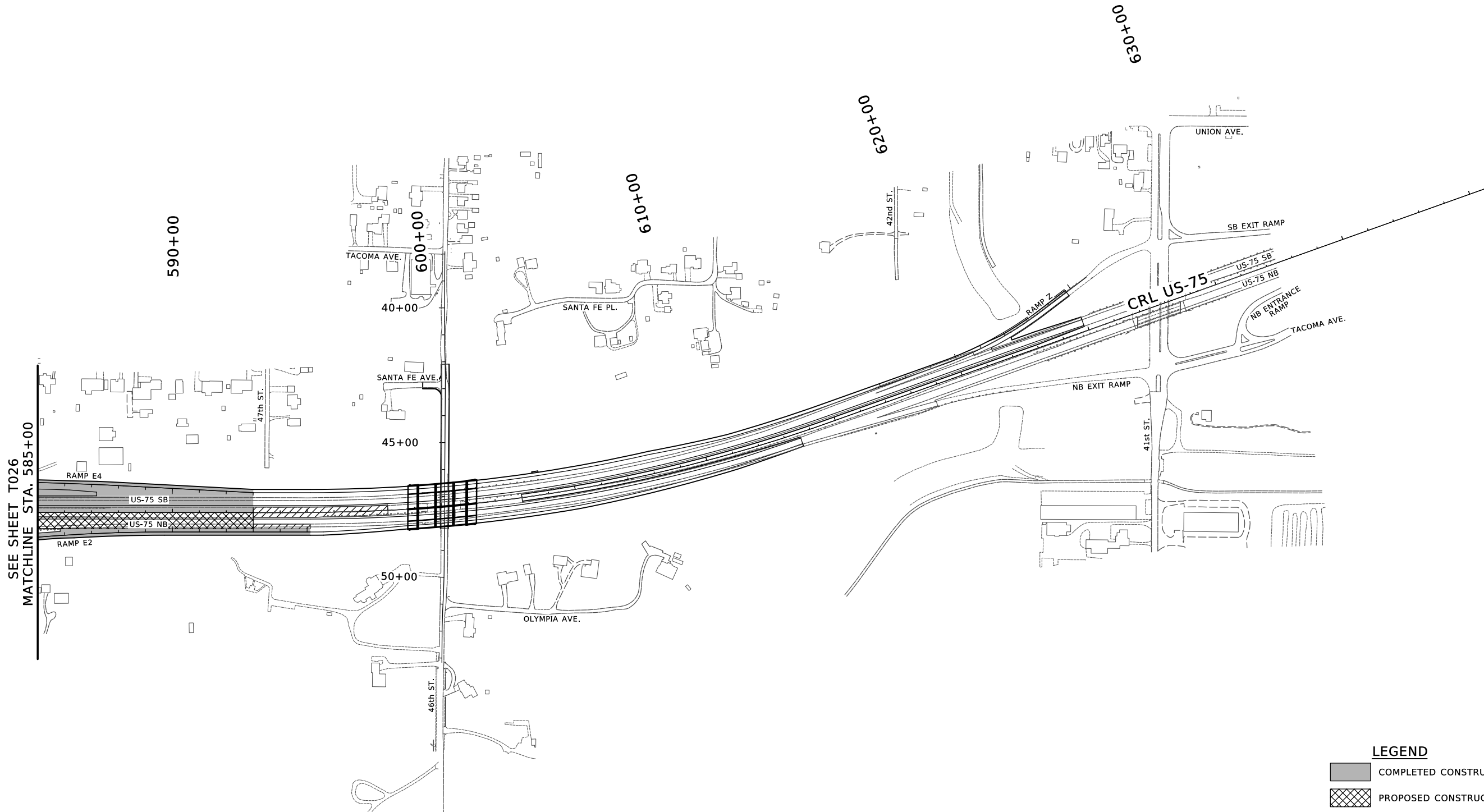
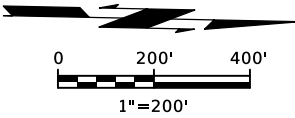

	COMPLETED CONSTRUCTION
	PROPOSED CONSTRUCTION
	TEMPORARY CONSTRUCTION
	WP 2 COMPLETED CONSTRUCTION

PHASE 4		OKLAHOMA DEPARTMENT OF TRANSPORTATION
DESIGN		
DRAWN		
CHECKED		
APPROVED		
SQUAD		
SUGGESTED CONSTRUCTION SEQUENCE (7)		
COUNTY - TULSA	HIGHWAY US-75	STATE JOB NO. 33788(11) SHEET NO. T026



SEE SHEET T026
MATCHLINE STA. 585+00

LEGEND

-  COMPLETED CONSTRUCTION
-  PROPOSED CONSTRUCTION
-  TEMPORARY CONSTRUCTION
-  WP 2 COMPLETED CONSTRUCTION

PHASE 4

DESIGN		OKLAHOMA DEPARTMENT OF TRANSPORTATION SUGGESTED CONSTRUCTION SEQUENCE (8)
DRAWN		
CHECKED		
APPROVED		
SQUAD		

R/W UTILITY MEETING

MARCH 2021

SEE SHEET T029
MATCHLINE STA. 585+00

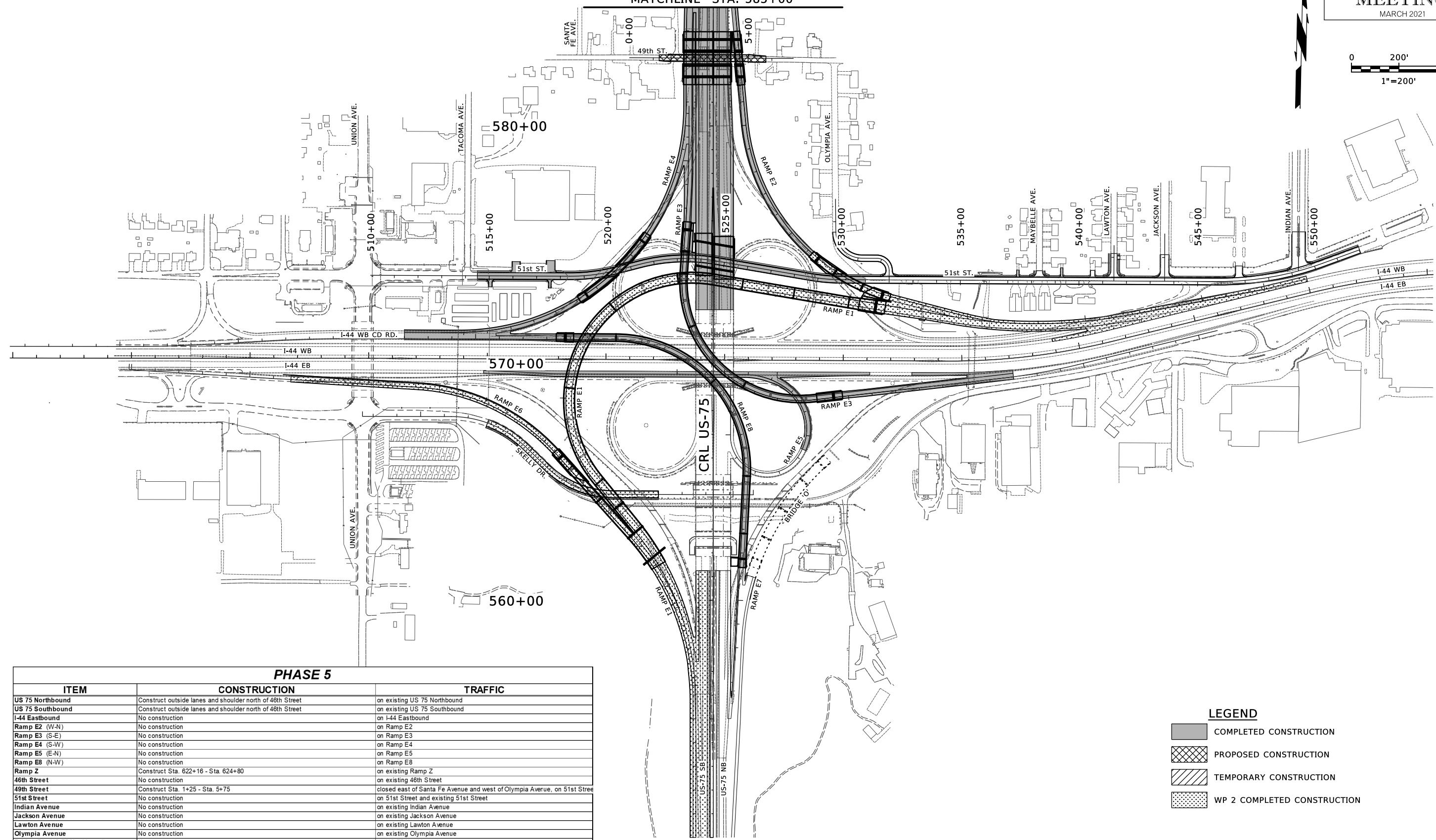
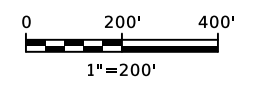

PHASE 5		
ITEM	CONSTRUCTION	TRAFFIC
US 75 Northbound	Construct outside lanes and shoulder north of 46th Street	on existing US 75 Northbound
US 75 Southbound	Construct outside lanes and shoulder north of 46th Street	on existing US 75 Southbound
I-44 Eastbound	No construction	on I-44 Eastbound
Ramp E2 (W-N)	No construction	on Ramp E2
Ramp E3 (S-E)	No construction	on Ramp E3
Ramp E4 (S-W)	No construction	on Ramp E4
Ramp E5 (E-N)	No construction	on Ramp E5
Ramp E8 (N-W)	No construction	on Ramp E8
Ramp Z	Construct Sta. 622+16 - Sta. 624+80	on existing Ramp Z
46th Street	No construction	on existing 46th Street
49th Street	Construct Sta. 1+25 - Sta. 5+75	closed east of Santa Fe Avenue and west of Olympia Avenue, on 51st Street
51st Street	No construction	on 51st Street and existing 51st Street
Indian Avenue	No construction	on existing Indian Avenue
Jackson Avenue	No construction	on existing Jackson Avenue
Lawton Avenue	No construction	on existing Lawton Avenue
Olympia Avenue	No construction	on existing Olympia Avenue
Bridge F1 (US 75 Northbound)	No construction	on US 75 Northbound
Bridge F2 (US 75 Southbound)	No construction	on US 75 Southbound
Bridge G1 (US 75 Northbound)	Construct east portion (outside lanes and shoulder)	on existing US 75 Northbound
Bridge G2 (US 75 Southbound)	Construct west portion (outside lanes and shoulder)	on existing US 75 Southbound
Bridge J1 (US 75 Northbound)	No construction	on US 75 Northbound
Bridge J2 (US 75 SB & Ramp E4 / E3)	No construction	on US 75 Southbound
Bridge J3 (Ramp E2)	No construction	on Ramp E2
Bridge L (Ramp E3)	No construction	on Ramp E3
Bridge M (Ramp E4)	No construction	on Ramp E4
Bridge P (Ramp E8)	No construction	on Ramp E8

LEGEND

- COMPLETED CONSTRUCTION
- PROPOSED CONSTRUCTION
- TEMPORARY CONSTRUCTION
- WP 2 COMPLETED CONSTRUCTION

PHASE 5		OKLAHOMA DEPARTMENT OF TRANSPORTATION
DESIGN		
DRAWN		
CHECKED		
APPROVED		
SQUAD		
SUGGESTED CONSTRUCTION SEQUENCE (9)		
COUNTY - TULSA	HIGHWAY US-75	STATE JOB NO. 33788(11) SHEET NO. T028



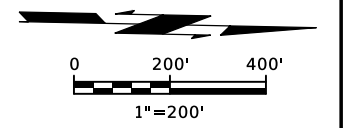

R/W UTILITY MEETING

MARCH 2021



SEE SHEET T028
MATCHLINE STA. 585+00

LEGEND

	COMPLETED CONSTRUCTION
	PROPOSED CONSTRUCTION
	TEMPORARY CONSTRUCTION
	WP 2 COMPLETED CONSTRUCTION

PHASE 5

DESIGN		OKLAHOMA DEPARTMENT OF TRANSPORTATION
DRAWN		
CHECKED		
APPROVED		
SQUAD		
SUGGESTED CONSTRUCTION SEQUENCE (10)		
COUNTY	TULSA	
HIGHWAY	US-75	
STATE JOB NO.	33788(11)	
SHEET NO.	T029	

SEE SHEET T031
MATCHLINE STA. 585+00

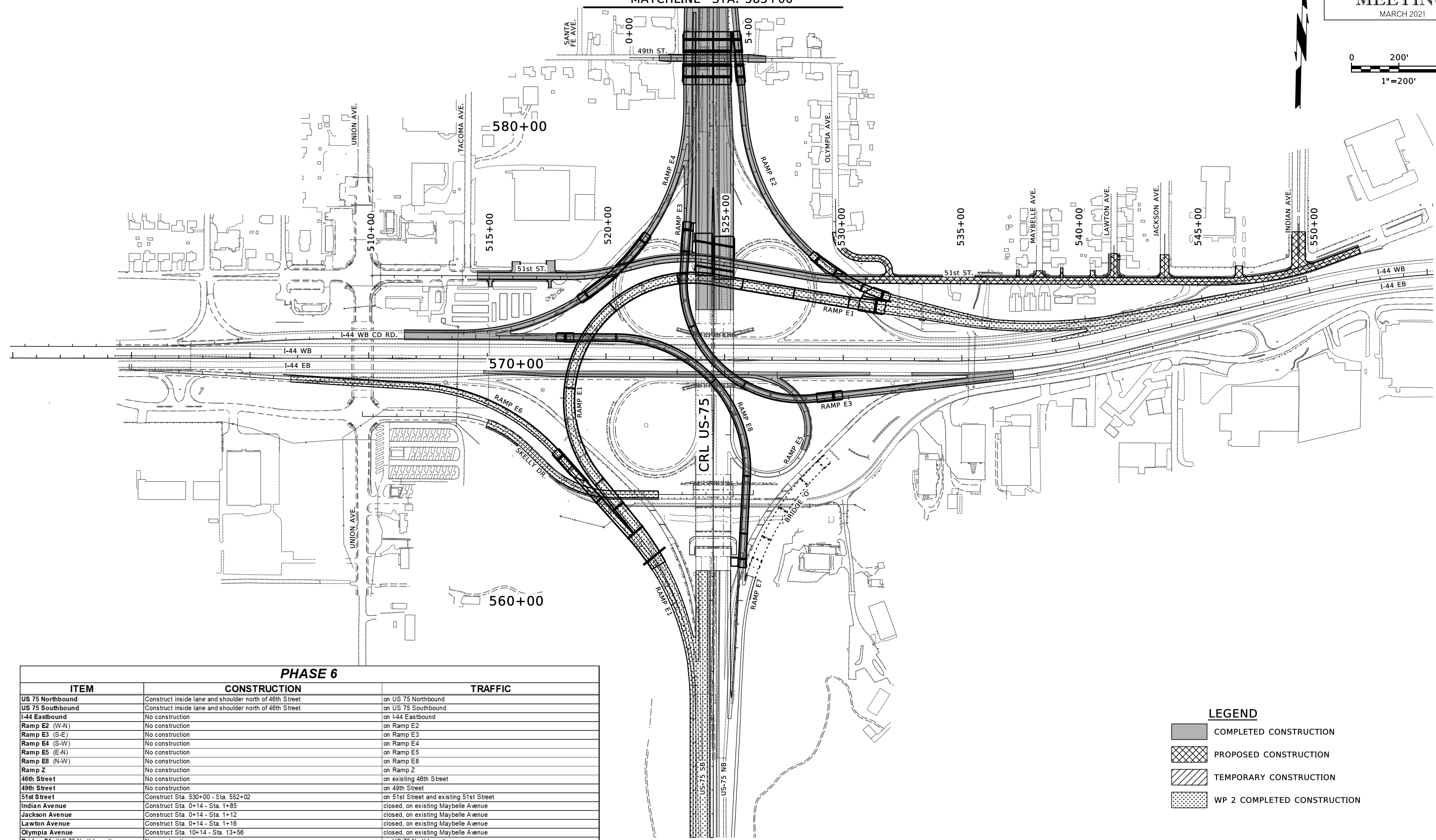
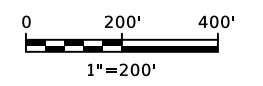

PHASE 6		
ITEM	CONSTRUCTION	TRAFFIC
US 75 Northbound	Construct inside lane and shoulder north of 46th Street	on US 75 Northbound
US 75 Southbound	Construct inside lane and shoulder north of 46th Street	on US 75 Southbound
I-44 Eastbound	No construction	on I-44 Eastbound
Ramp E2 (W-N)	No construction	on Ramp E2
Ramp E3 (S-E)	No construction	on Ramp E3
Ramp E4 (S-W)	No construction	on Ramp E4
Ramp E5 (E-N)	No construction	on Ramp E5
Ramp E8 (N-W)	No construction	on Ramp E8
Ramp Z	No construction	on Ramp Z
46th Street	No construction	on existing 46th Street
49th Street	No construction	on 49th Street
51st Street	Construct Sta. 530+00 - Sta. 552+02	on 51st Street and existing 51st Street
Indian Avenue	Construct Sta. 0+14 - Sta. 1+85	closed, on existing Maybelle Avenue
Jackson Avenue	Construct Sta. 0+14 - Sta. 1+12	closed, on existing Maybelle Avenue
Lawton Avenue	Construct Sta. 0+14 - Sta. 1+16	closed, on existing Maybelle Avenue
Olympia Avenue	Construct Sta. 10+14 - Sta. 13+56	closed, on existing Maybelle Avenue
Bridge F1 (US 75 Northbound)	No construction	on US 75 Northbound
Bridge F2 (US 75 Southbound)	No construction	on US 75 Southbound
Bridge G1 (US 75 Northbound)	Construct west portion (inside lane and shoulder)	on US 75 Northbound
Bridge G2 (US 75 Southbound)	Construct east portion (inside lane and shoulder)	on US 75 Southbound
Bridge J1 (US 75 Northbound)	No construction	on US 75 Northbound
Bridge J2 (US 75 SB & Ramp E4 / E3)	No construction	on US 75 Southbound
Bridge J3 (Ramp E2)	No construction	on Ramp E2
Bridge L (Ramp E3)	No construction	on Ramp E3
Bridge M (Ramp E4)	No construction	on Ramp E4
Bridge P (Ramp E8)	No construction	on Ramp E8

LEGEND



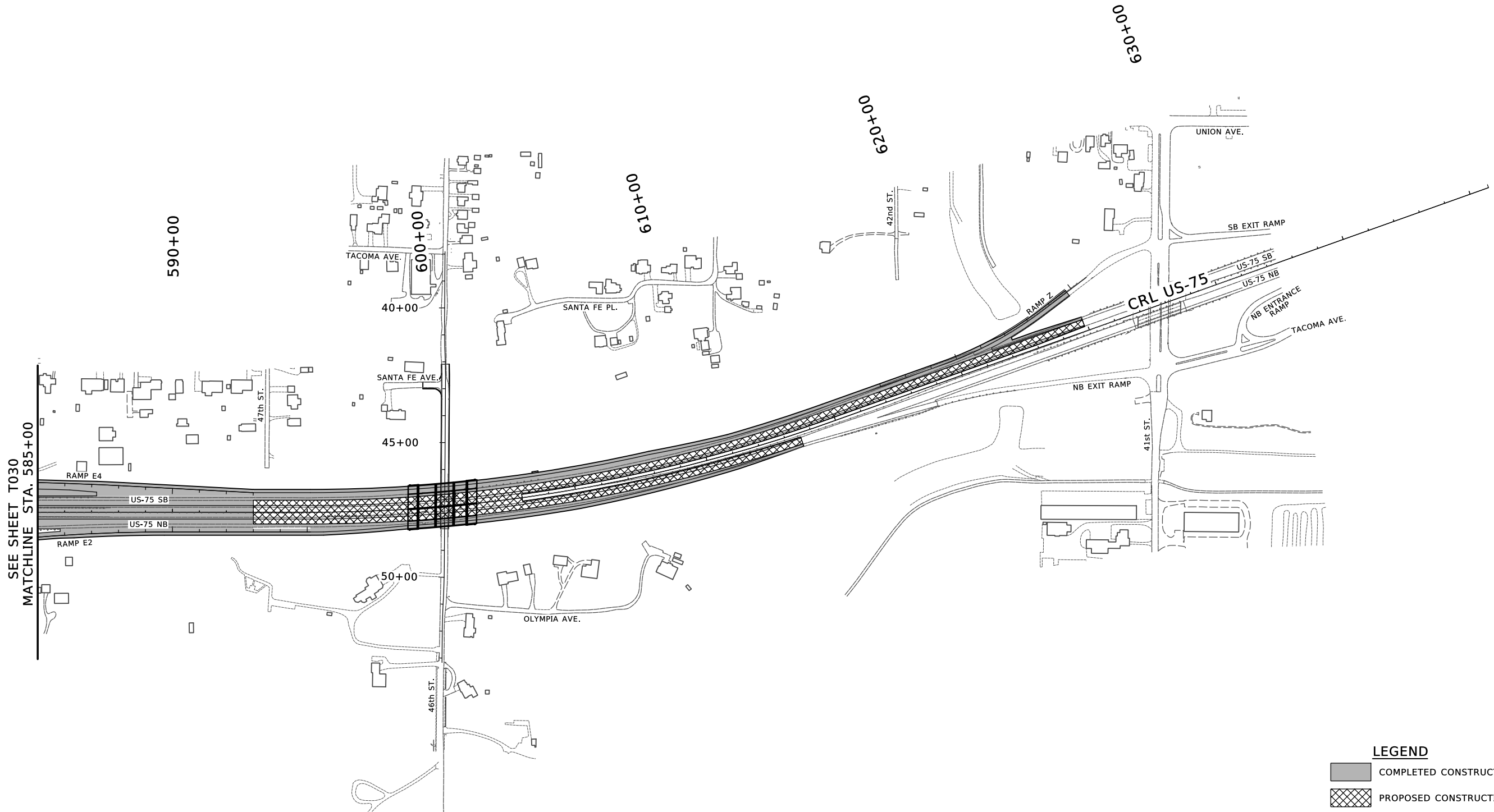
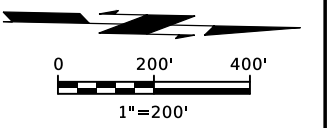

	COMPLETED CONSTRUCTION
	PROPOSED CONSTRUCTION
	TEMPORARY CONSTRUCTION
	WP 2 COMPLETED CONSTRUCTION

PHASE 6		OKLAHOMA DEPARTMENT OF TRANSPORTATION
DESIGN		SUGGESTED CONSTRUCTION SEQUENCE (11)
DRAWN		
CHECKED		
APPROVED		
SQUAD		
COUNTY - TULSA		HIGHWAY US-75 STATE JOB NO. 33788(11) SHEET NO. T030



SEE SHEET T030
MATCHLINE STA. 585+00

LEGEND

	COMPLETED CONSTRUCTION
	PROPOSED CONSTRUCTION
	TEMPORARY CONSTRUCTION
	WP 2 COMPLETED CONSTRUCTION

PHASE 6

DESIGN		OKLAHOMA DEPARTMENT OF TRANSPORTATION
DRAWN		
CHECKED		
APPROVED		
SQUAD		
SUGGESTED CONSTRUCTION SEQUENCE (12)		
COUNTY	TULSA	HIGHWAY US-75 STATE JOB NO. 33788(11) SHEET NO. T031

SEE SHEET T033
MATCHLINE STA. 585+00

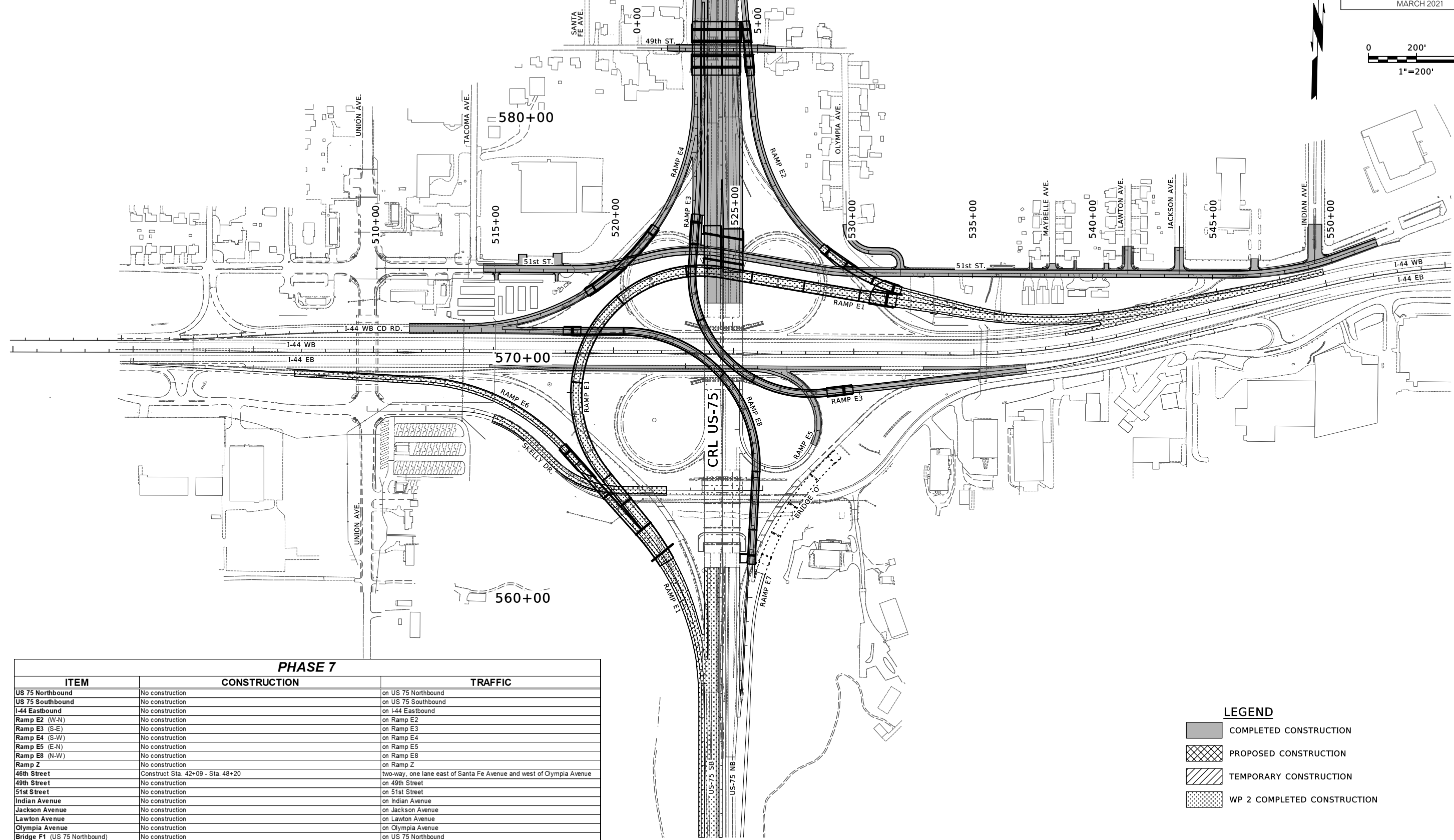
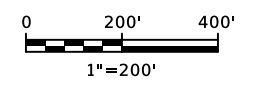

PHASE 7		
ITEM	CONSTRUCTION	TRAFFIC
US 75 Northbound	No construction	on US 75 Northbound
US 75 Southbound	No construction	on US 75 Southbound
I-44 Eastbound	No construction	on I-44 Eastbound
Ramp E2 (W-N)	No construction	on Ramp E2
Ramp E3 (S-E)	No construction	on Ramp E3
Ramp E4 (S-W)	No construction	on Ramp E4
Ramp E5 (E-N)	No construction	on Ramp E5
Ramp E8 (N-W)	No construction	on Ramp E8
Ramp Z	No construction	on Ramp Z
46th Street	Construct Sta. 42+09 - Sta. 48+20	two-way, one lane east of Santa Fe Avenue and west of Olympia Avenue
49th Street	No construction	on 49th Street
51st Street	No construction	on 51st Street
Indian Avenue	No construction	on Indian Avenue
Jackson Avenue	No construction	on Jackson Avenue
Lawton Avenue	No construction	on Lawton Avenue
Olympia Avenue	No construction	on Olympia Avenue
Bridge F1 (US 75 Northbound)	No construction	on US 75 Northbound
Bridge F2 (US 75 Southbound)	No construction	on US 75 Southbound
Bridge G1 (US 75 Northbound)	No construction	on US 75 Northbound
Bridge G2 (US 75 Southbound)	No construction	on US 75 Southbound
Bridge J1 (US 75 Northbound)	No construction	on US 75 Northbound
Bridge J2 (US 75 SB & Ramp E4 / E3)	No construction	on US 75 Southbound
Bridge J3 (Ramp E2)	No construction	on Ramp E2
Bridge L (Ramp E3)	No construction	on Ramp E3
Bridge M (Ramp E4)	No construction	on Ramp E4
Bridge P (Ramp E8)	No construction	on Ramp E8

LEGEND

	COMPLETED CONSTRUCTION
	PROPOSED CONSTRUCTION
	TEMPORARY CONSTRUCTION
	WP 2 COMPLETED CONSTRUCTION



PHASE 7		OKLAHOMA DEPARTMENT OF TRANSPORTATION
DESIGN		
DRAWN		
CHECKED		
APPROVED		
SQUAD		
SUGGESTED CONSTRUCTION SEQUENCE (13)		
COUNTY - TULSA	HIGHWAY US-75	STATE JOB NO. 33788(11) SHEET NO. T032

R/W UTILITY MEETING

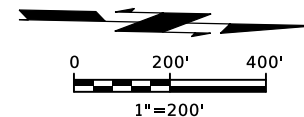
MARCH 2021

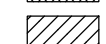
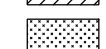

LEGEND

-  COMPLETED CONSTRUCTION
-  PROPOSED CONSTRUCTION
-  TEMPORARY CONSTRUCTION
-  WP 2 COMPLETED CONSTRUCTION

PHASE 7

DESIGN		OKLAHOMA DEPARTMENT OF TRANSPORTATION SUGGESTED CONSTRUCTION SEQUENCE (14)
DRAWN		
CHECKED		
APPROVED		
SQUAD		
COUNTY - TULSA		HIGHWAY US-75 STATE JOB NO. 33788(11) SHEET NO. T033

R/W UTILITY MEETING

MARCH 2021

3/4/2021

END AREAS (SF)

VOLUMES (CY)

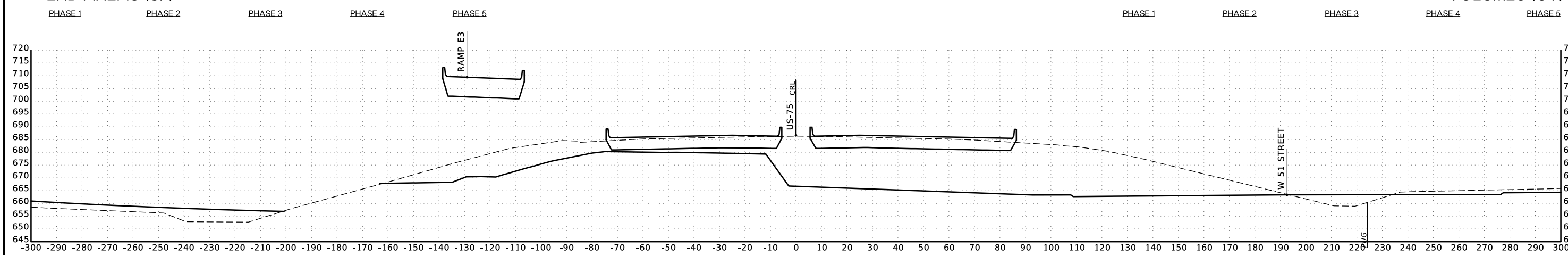

STA. 574+02.24 - BEGIN BRIDGE 'F2'

574+00

STA. 573+93.76 - BEGIN BRIDGE 'F1'



573+00

STA. 572+25 - BEGIN PROJECT

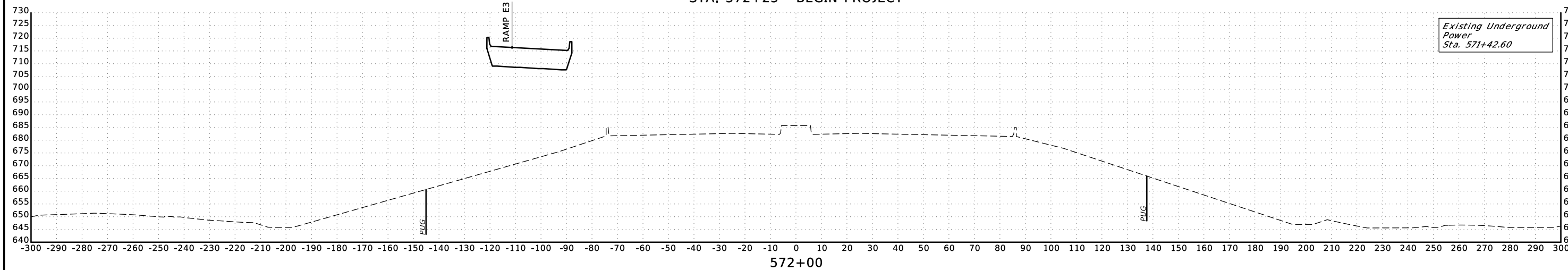

572+00

US-75 STA. 572+00 TO STA. 574+00

P:\FDB\1650-TUL\CIV\40035_000T_EC2123A_US75_Design-Working\CIV\MicroStation\33788II-WP5\33788II-CrossSections.dgn

SCALE: 1"= 20'

3/4/2021

END AREAS (SF)

VOLUMES (CY)

PHASE 1 PHASE 2 PHASE 3 PHASE 4 PHASE 5 PHASE 1 PHASE 2 PHASE 3 PHASE 4 PHASE 5

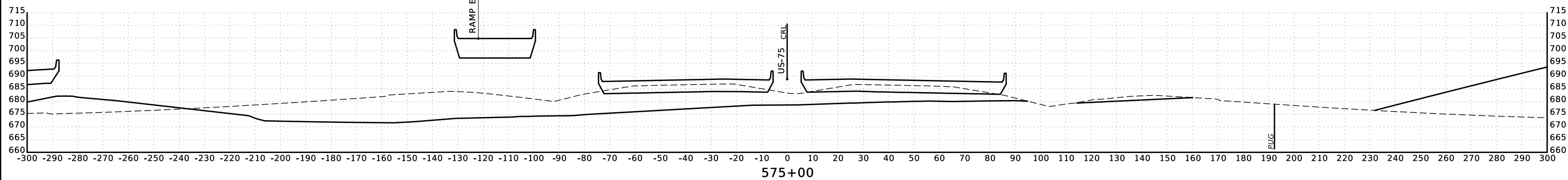
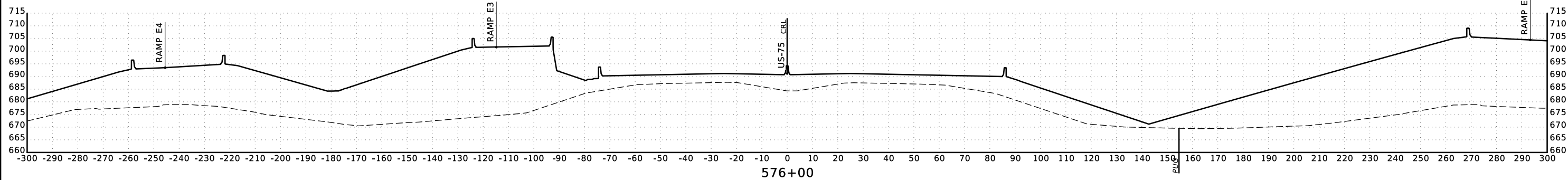
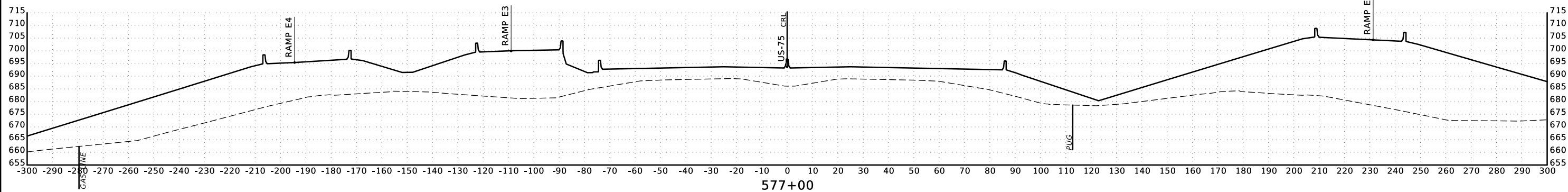
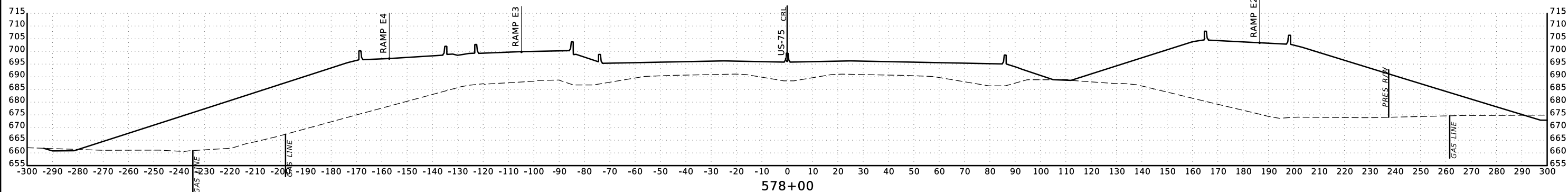

STA. 575+09.24 - END BRIDGE 'F2'

STA. 575+00.76 - END BRIDGE 'F1'

US-75 STA. 575+00 TO STA. 578+00

SCALE: 1" = 20'

P:\FDB\1650-TUL\CIV\400315_000T_EC2123A_US75_Design-Working\CIV\MicroStation\3378811-CrossSections.dgn

R/W UTILITY MEETING

MARCH 2021

3/4/2021

END AREAS (SF)

VOLUMES (CY)

PHASE 1 PHASE 2 PHASE 3 PHASE 4 PHASE 5 PHASE 1 PHASE 2 PHASE 3 PHASE 4 PHASE 5

STA. 582+04.12 - BEGIN BRIDGE 'J2'

STA. 582+04.12 - BEGIN BRIDGE 'J1'

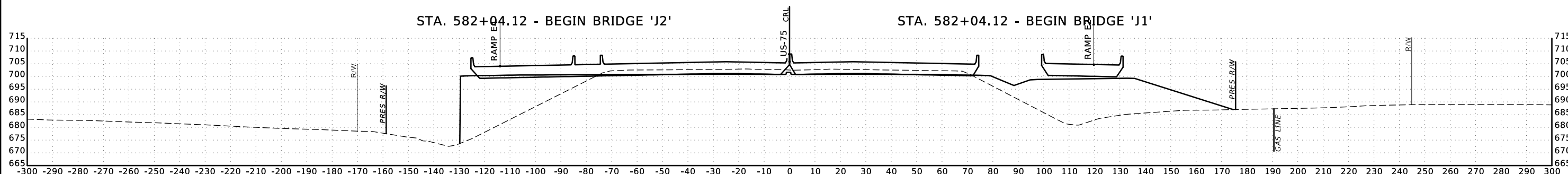

582+00

Existing Gas Line Sta. 581+16.27

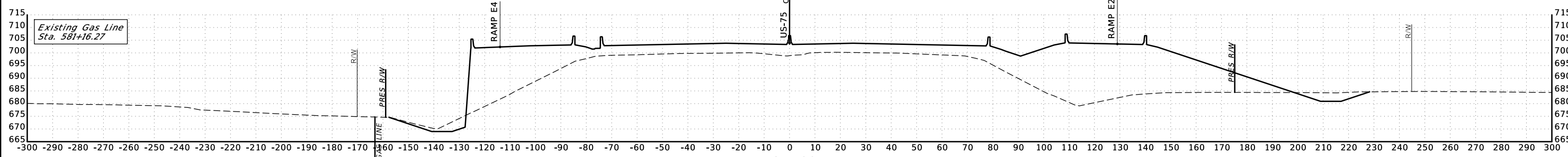

581+00

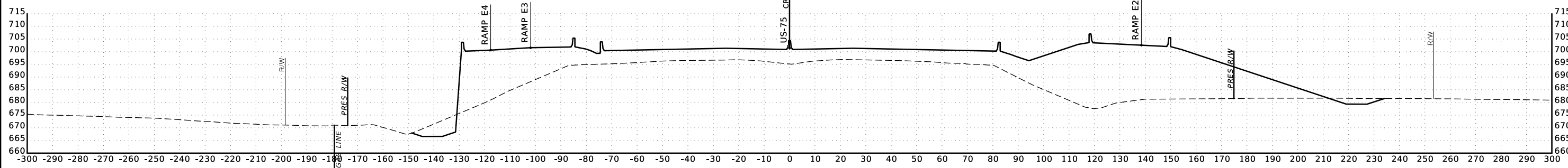

580+00

Existing Gas Line Sta. 578+59.78

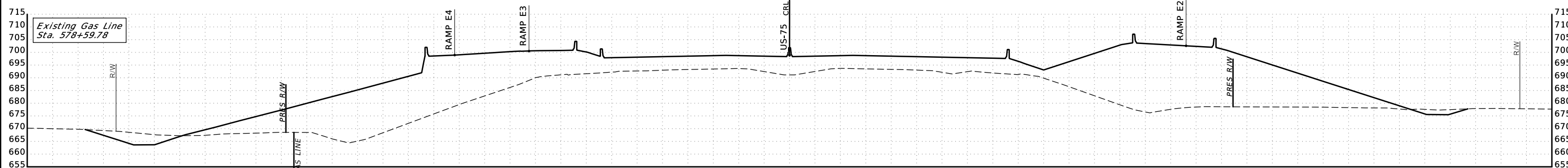

579+00

US-75 STA. 579+00 TO STA. 582+00

P:\FDB\1650-TUL\CIV\400315_000T_EC2123A_US75_Design-Working\CIV\MicroStation\3378811-WP5\3378811-CrossSections.dgn

SCALE: 1"= 20'

3/4/2021

END AREAS (SF)

VOLUMES (CY)

PHASE 1 PHASE 2 PHASE 3 PHASE 4 PHASE 5 PHASE 1 PHASE 2 PHASE 3 PHASE 4 PHASE 5

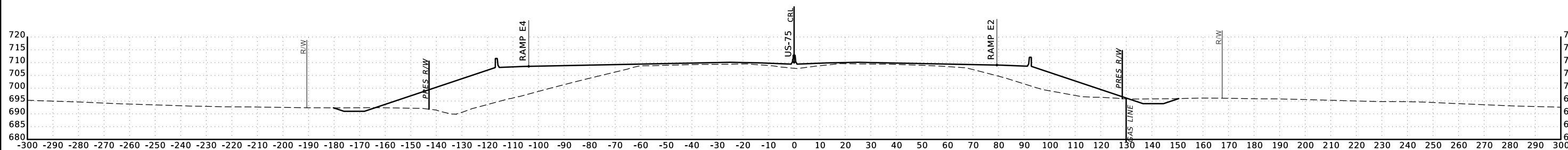

587+00

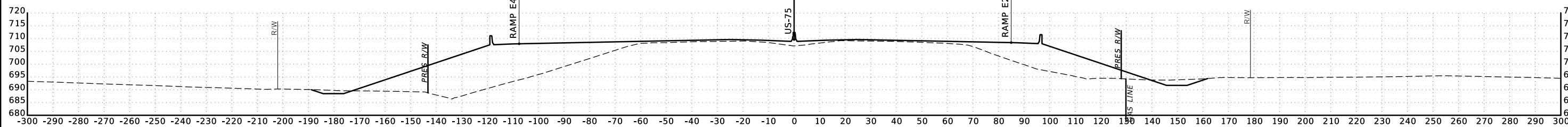

586+00

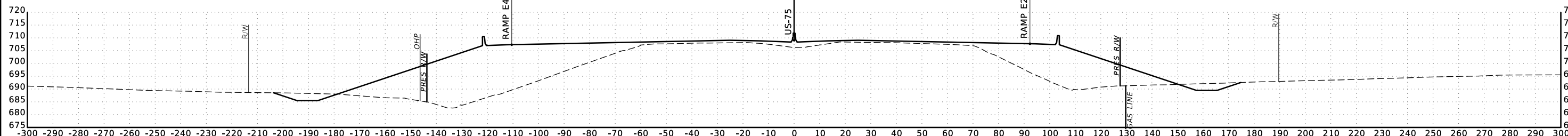

585+00

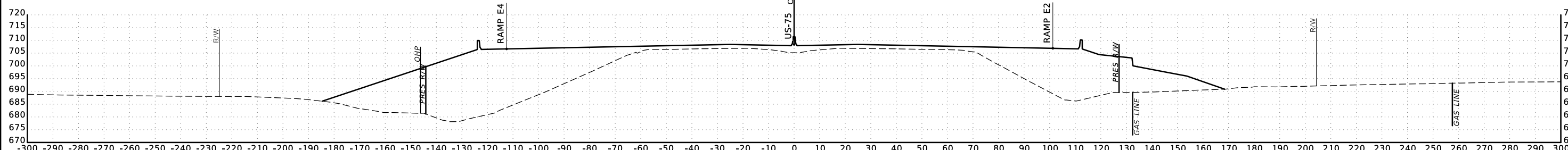

584+00

STA. 583+67.12 - END BRIDGE 'J2'

STA. 583+67.12 - END BRIDGE 'J1'

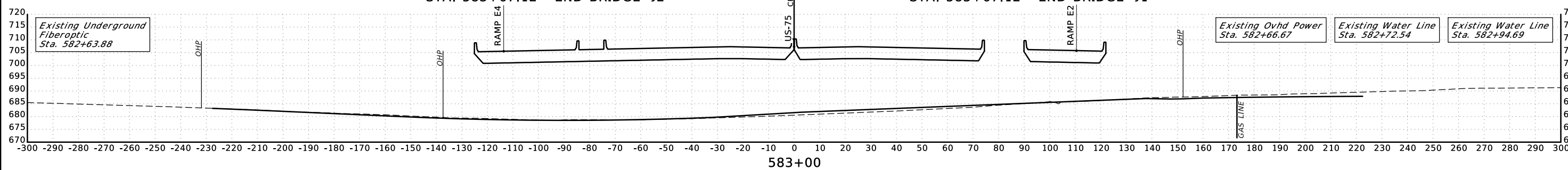

583+00

Existing Underground
Fiberoptic
Sta. 582+63.88

Existing Ovhd Power
Sta. 582+66.67

Existing Water Line
Sta. 582+72.54

Existing Water Line
Sta. 582+94.69

US-75 STA. 583+00 TO STA. 587+00

P:\FDB\1650-TUL\CIV\400315_ODOT_EC2123A_US75\Design-Working\CIV\MicroStation\3378811-CrossSections.dgn

SCALE: 1"= 20'

3/4/2021

END AREAS (SF)

VOLUMES (CY)

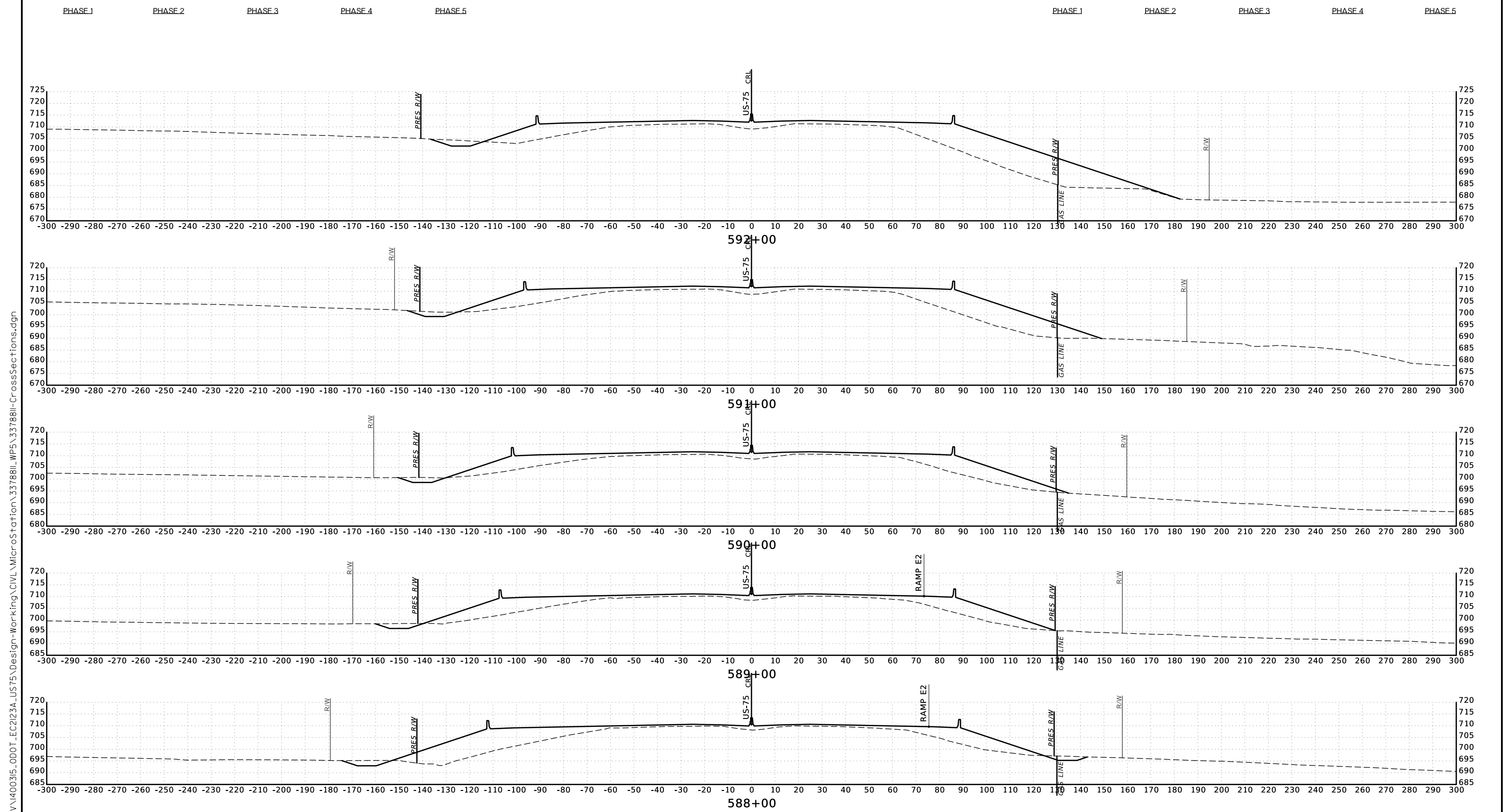

P:\FDB\1650-TUL\CIV\400315_ODOT_EC2123A_US75\Design-Working\CIV\MicroStation\3378811-WP5\3378811-CrossSections.dgn

US-75 STA. 588+00 TO STA. 592+00

SCALE: 1" = 20'

R/W UTILITY MEETING

MARCH 2021

3/4/2021

END AREAS (SF)

VOLUMES (CY)

PHASE 1 PHASE 2 PHASE 3 PHASE 4 PHASE 5 PHASE 1 PHASE 2 PHASE 3 PHASE 4 PHASE 5

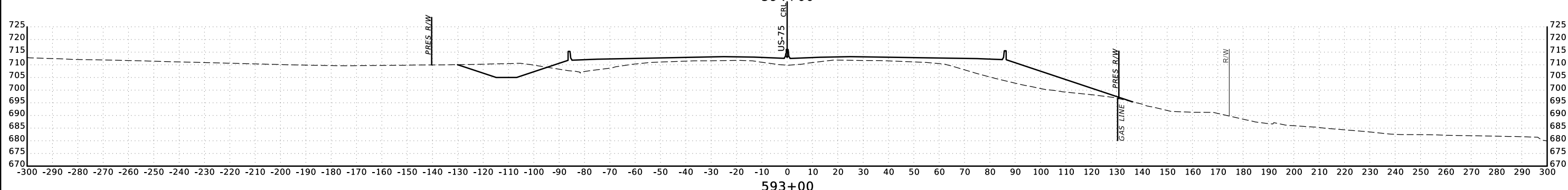
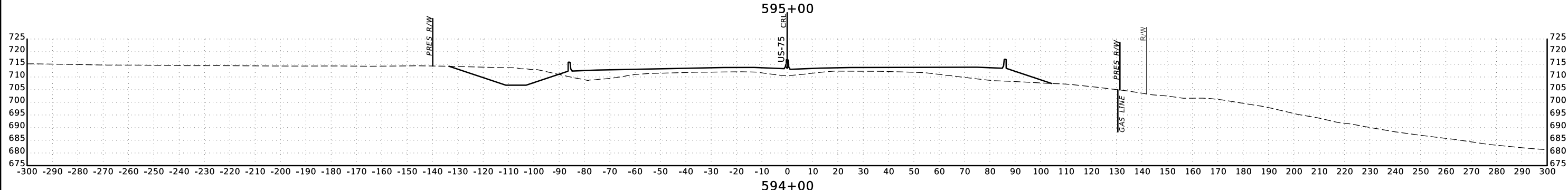
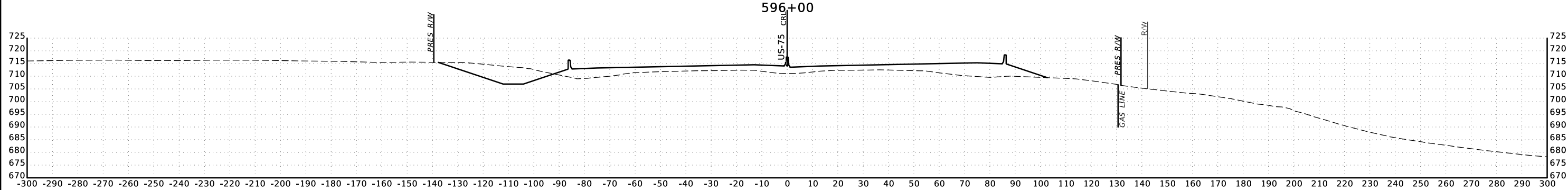
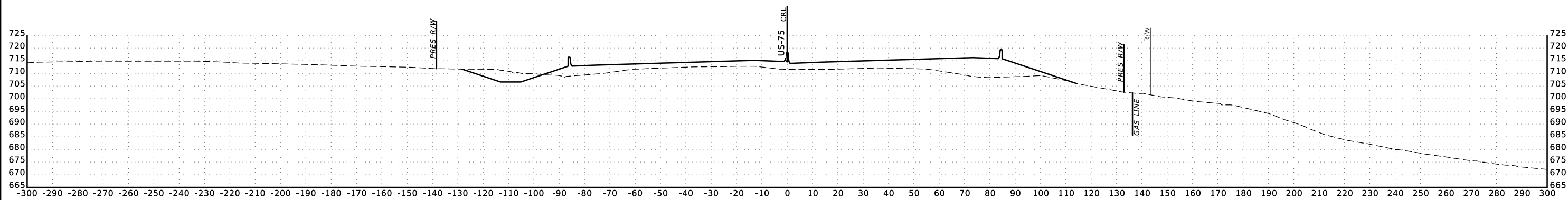

US-75 STA. 593+00 TO STA. 596+00

P:\FDB\1650-TUL\CIV\1400315_000T_EC2123A_US75_Design-Working\CIV\MicroStation\3378811-CrossSections.dgn

SCALE: 1" = 20'

3/4/2021

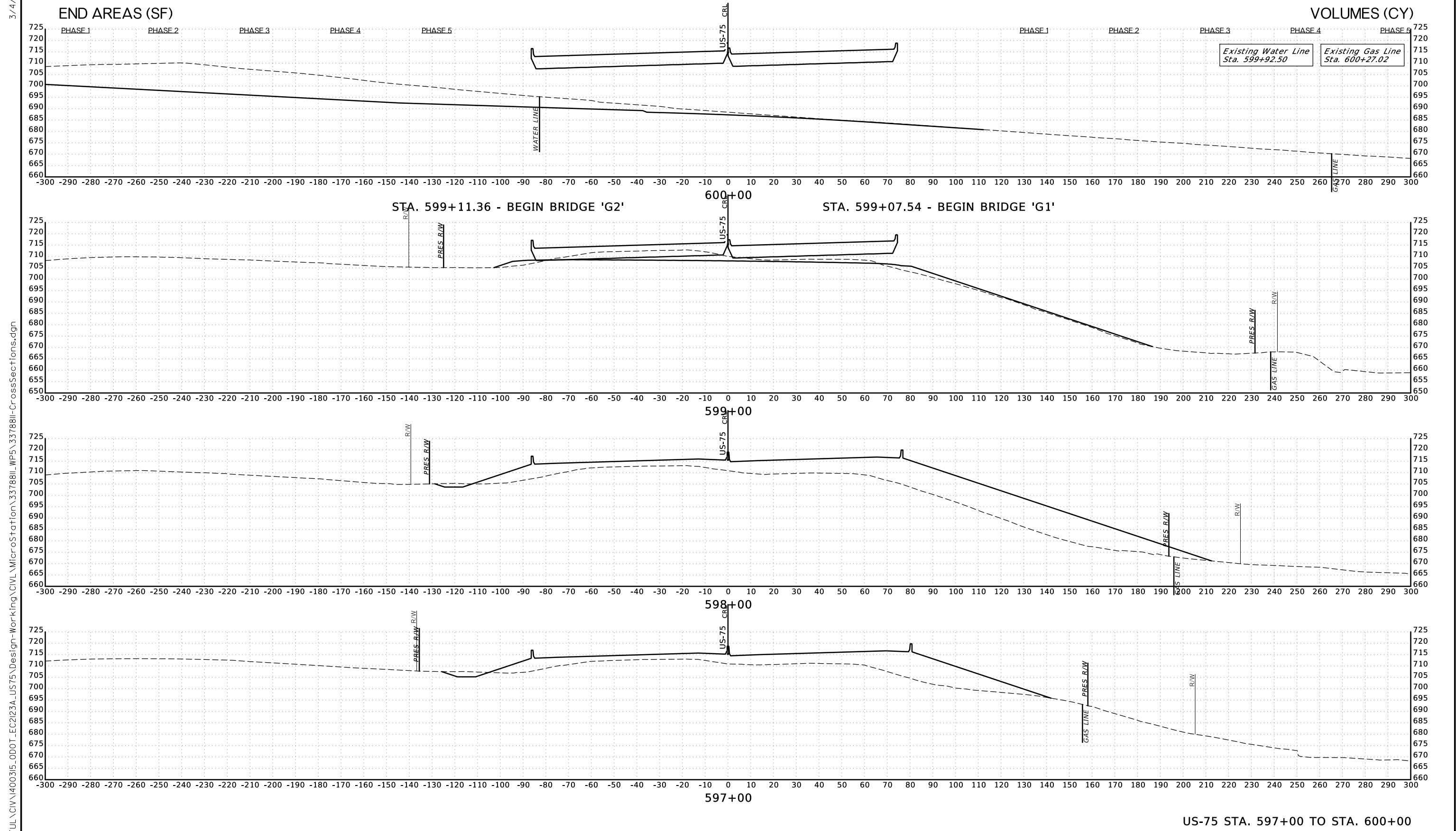

P:\FDB\1650-TUL\CIV\400315_000T_EC2123A_US75_Design-Working\CIV\MicroStation\3378811-WP5\3378811-CrossSections.dgn

3/4/2021
 P:\FDB\1650-TUL\CIV\40035_000T_EC2123A_US75_Design-Working\CIV\MicroStation\33788II-CrossSections.dgn

END AREAS (SF)

VOLUMES (CY)

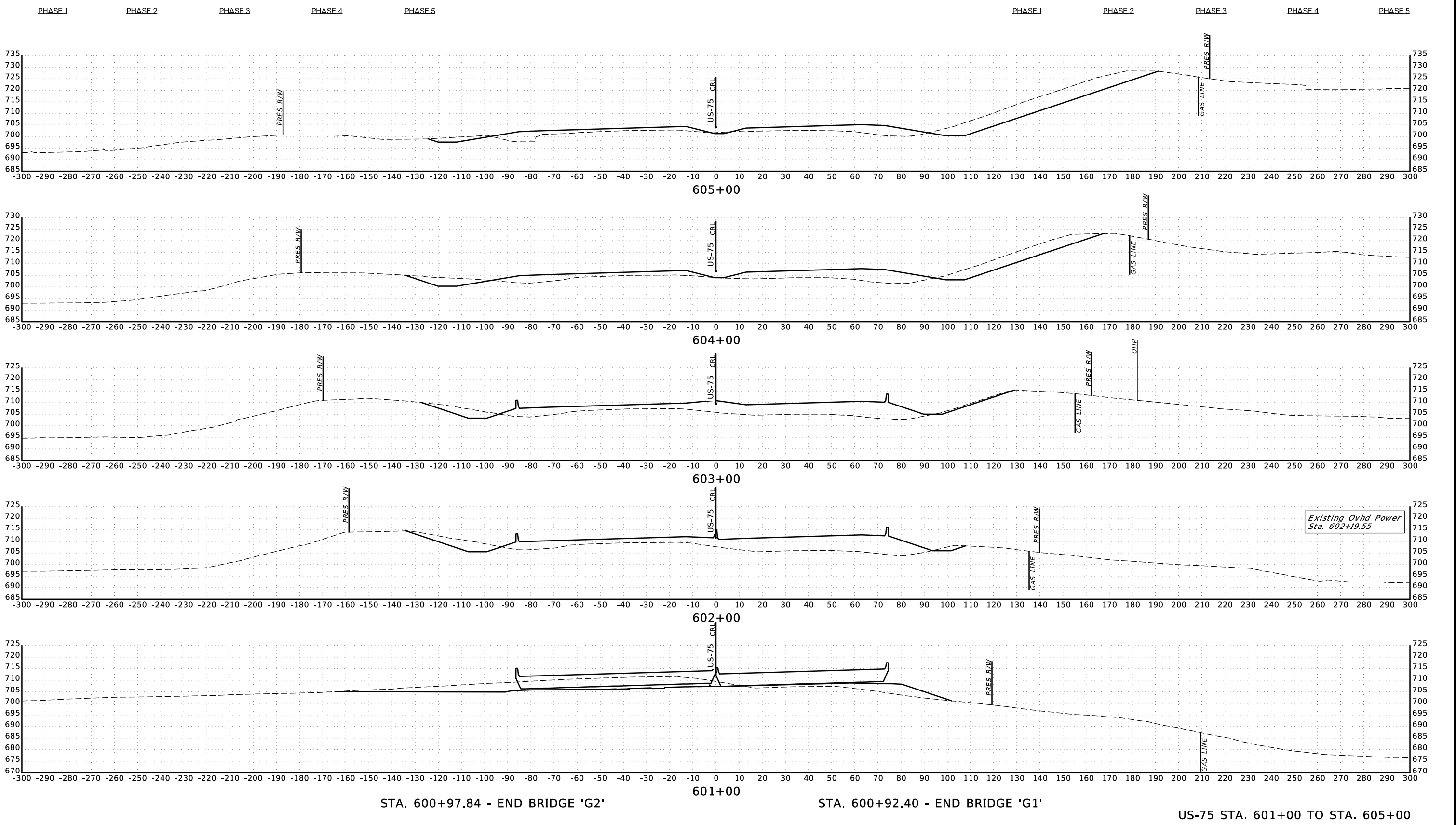

3/4/2021

P:\FDB\1650-TUL\CIV\400315_000T_EC2123A_US75_Design-Working\CIV\MicroStation\3378811-WP5\3378811-CrossSections.dgn

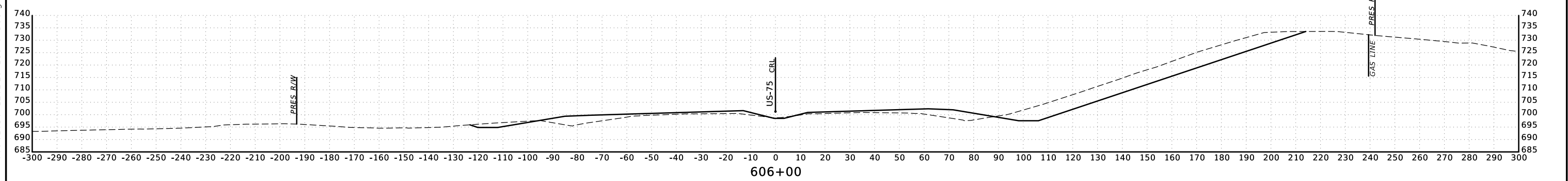
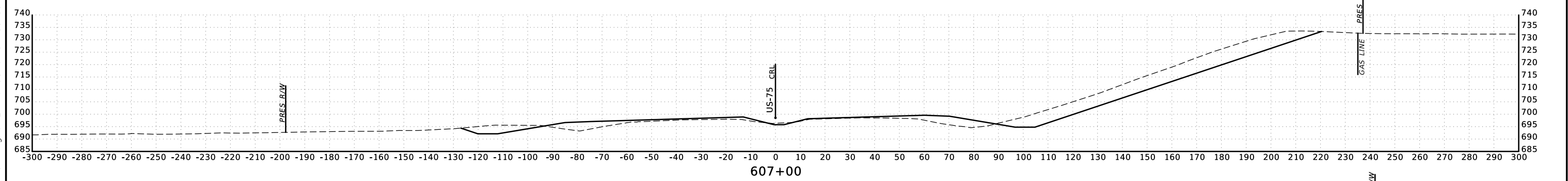
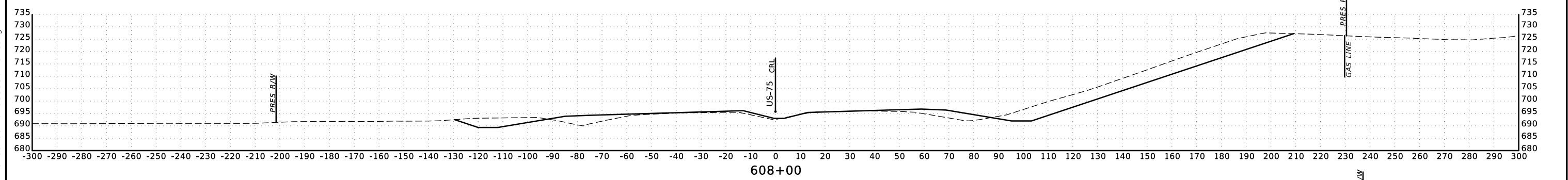
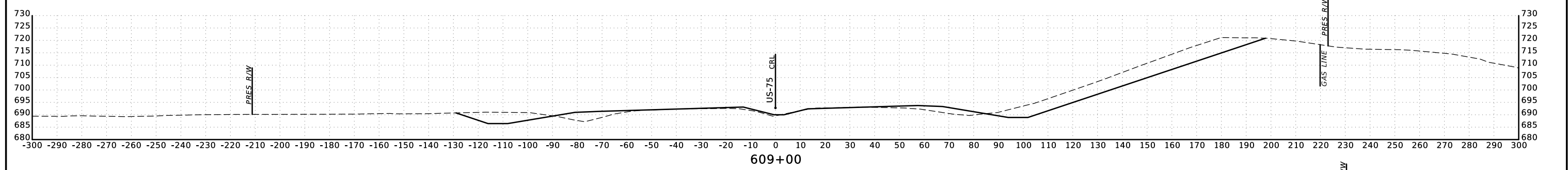
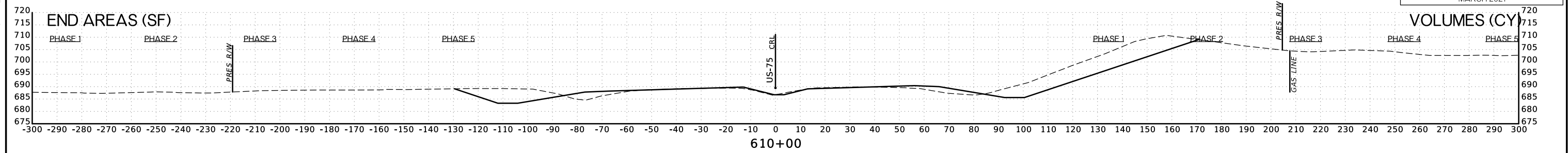

US-75 STA. 606+00 TO STA. 610+00

SCALE: 1" = 20'

3/4/2021

END AREAS (SF)

VOLUMES (CY)

PHASE 1 PHASE 2 PHASE 3 PHASE 4 PHASE 5 PHASE 1 PHASE 2 PHASE 3 PHASE 4 PHASE 5

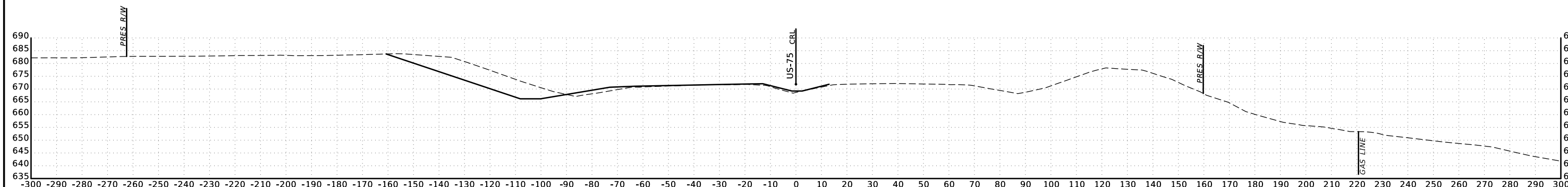

615+00

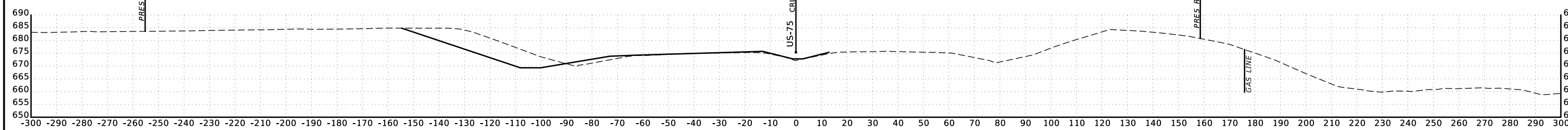

614+00

STA. 613+57.84 - END US-75 NB

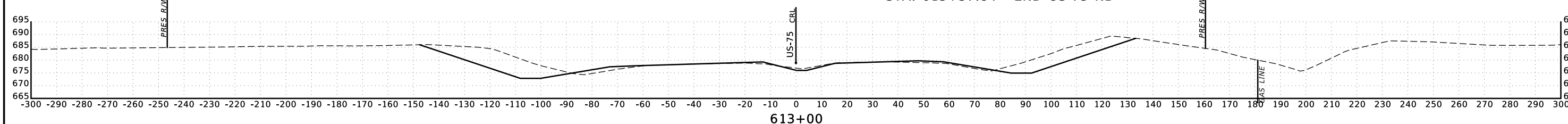

613+00

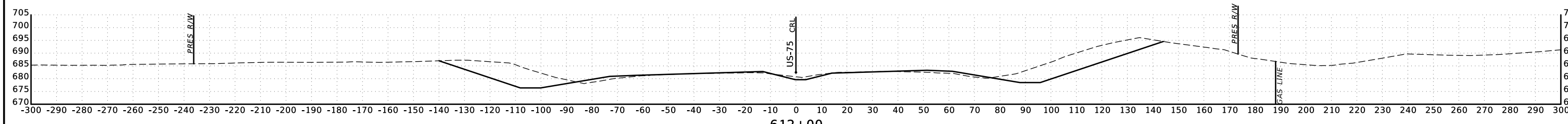

612+00

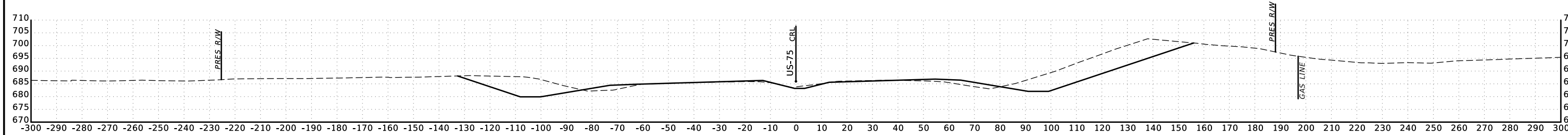

611+00

US-75 STA. 611+00 TO STA. 615+00

P:\FDB\1650-TUL\CIV\400315_000T_EC2123A_US75\Design-Working\CIV\MicroStation\3378811-WP5\3378811-CrossSections.dgn

SCALE: 1"= 20'

R/W UTILITY MEETING

MARCH 2021

3/4/2021

END AREAS (SF)

VOLUMES (CY)

PHASE 1 PHASE 2 PHASE 3 PHASE 4 PHASE 5 PHASE 1 PHASE 2 PHASE 3 PHASE 4 PHASE 5

P:\FDB\1650-TUL\CIV\400315_ODOT_EC2123A_US75_Design-Working\CIV\MicroStation\3378811-WP5\3378811-CrossSections.dgn

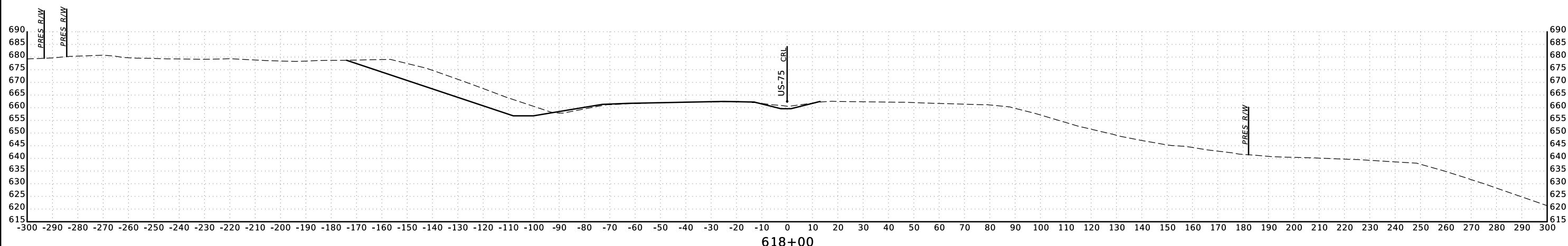

618+00

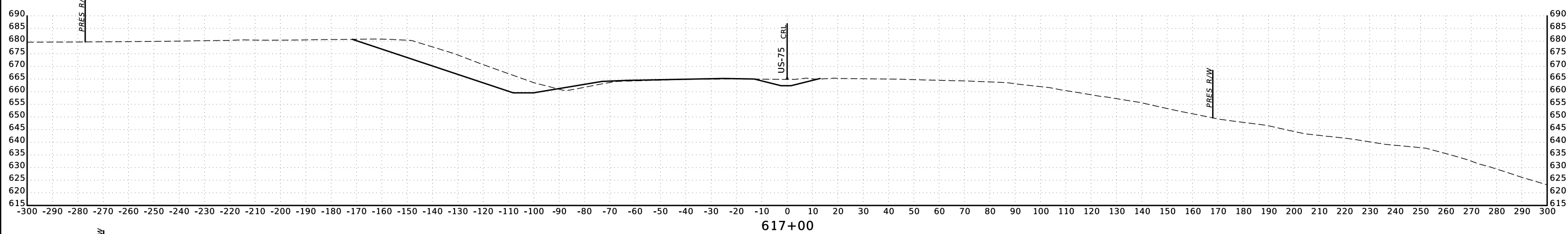

617+00

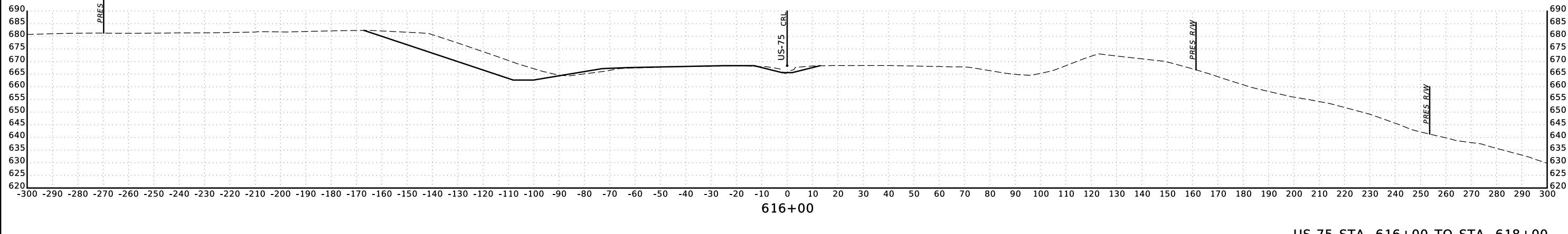

616+00

US-75 STA. 616+00 TO STA. 618+00

SCALE: 1"= 20'

3/4/2021

P:\FDB\1650-TUL\CIV\40035_ODOT_EC2123A_US75_Design-Working\CIV\MicroStation\33788II-WP5\33788II-CrossSections.dgn

END AREAS (SF)

VOLUMES (CY)

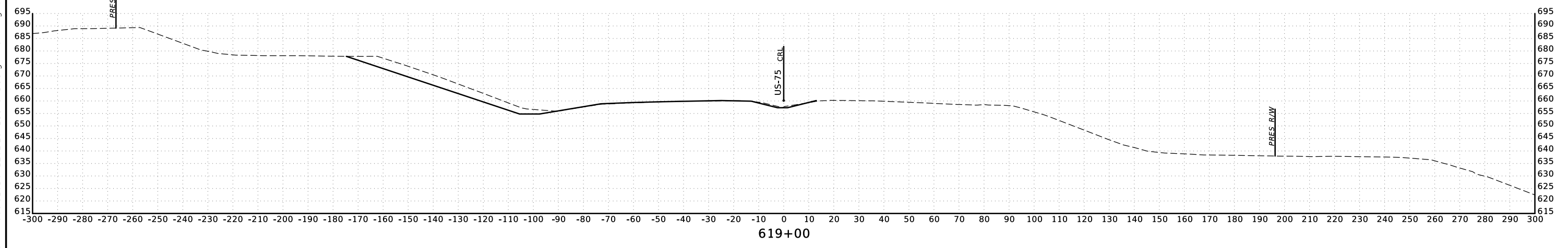
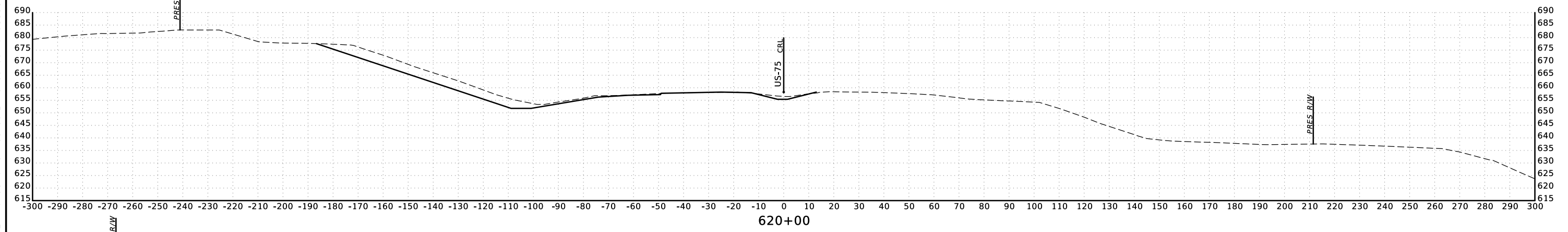
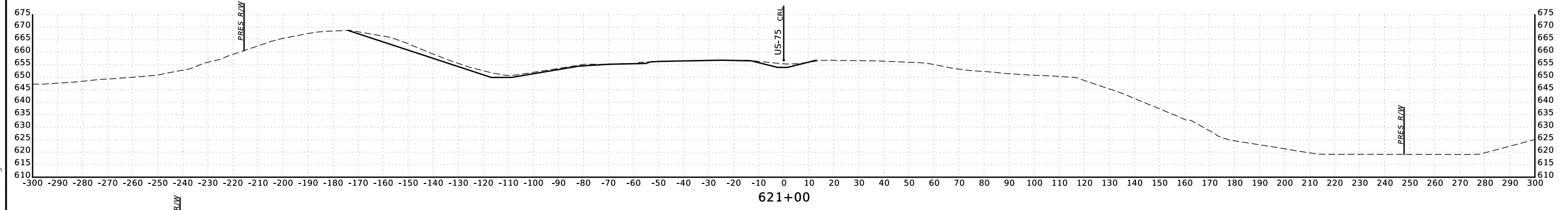
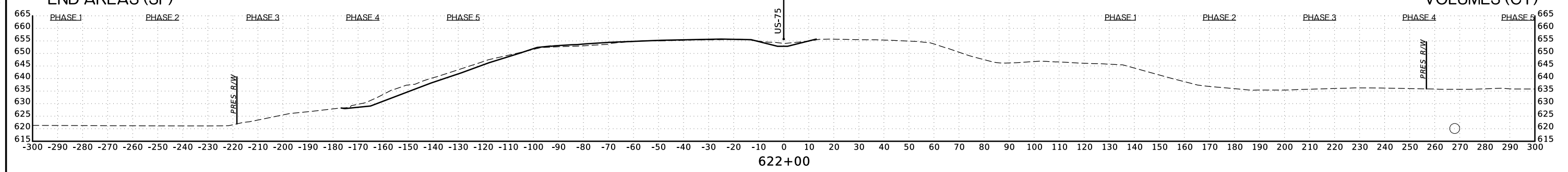

US-75 STA. 619+00 TO STA. 622+00

SCALE: 1" = 20'

3/4/2021

END AREAS (SF)

PHASE 1 PHASE 2 PHASE 3 PHASE 4 PHASE 5

VOLUMES (CY)

PHASE 1 PHASE 2 PHASE 3 PHASE 4 PHASE 5

P:\FDB\1650-TUL\CIV\400315_000T_EC2123A_US75\Design-Working\CIV\MicroStation\3378811-WP5\3378811-CrossSections.dgn

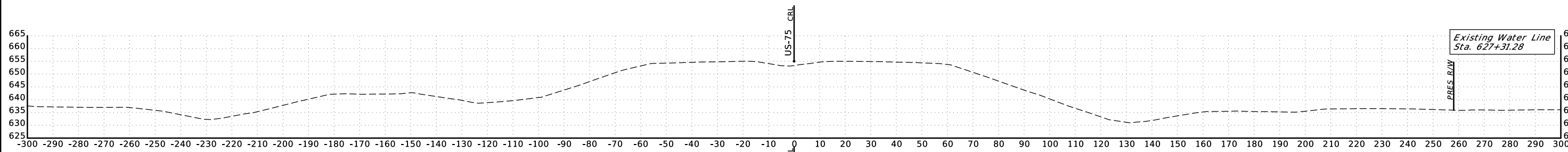

STA. 624+87.84 - END PROJECT

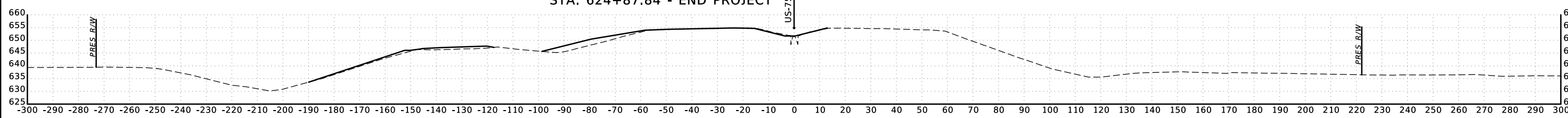

623+00

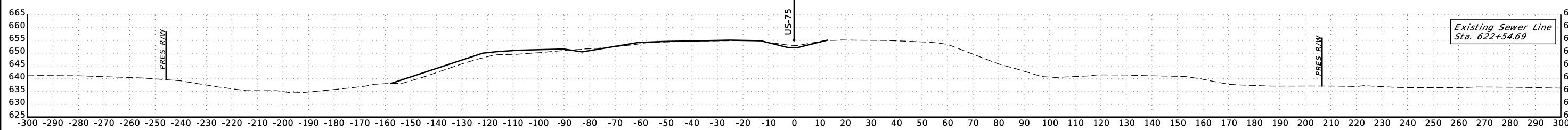

Existing Sewer Line
Sta. 622+54.69

623+00

US-75 STA. 623+00 TO STA. 625+00

SCALE: 1"= 20'

END AREAS (SF)

PHASE 1 PHASE 2 PHASE 3 PHASE 4 PHASE 5

VOLUMES (CY)

PHASE 1 PHASE 2 PHASE 3 PHASE 4 PHASE 5

STA. 73+78.50 - BEGIN RAMP E2

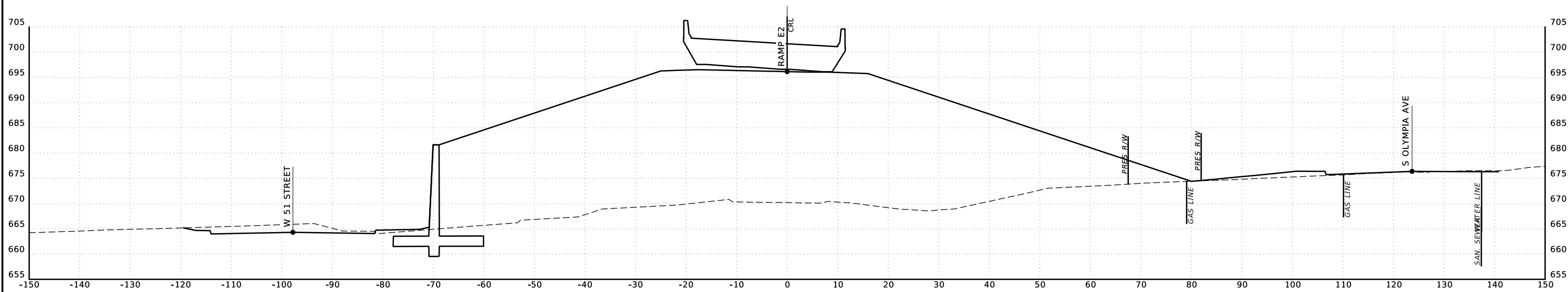

73+50

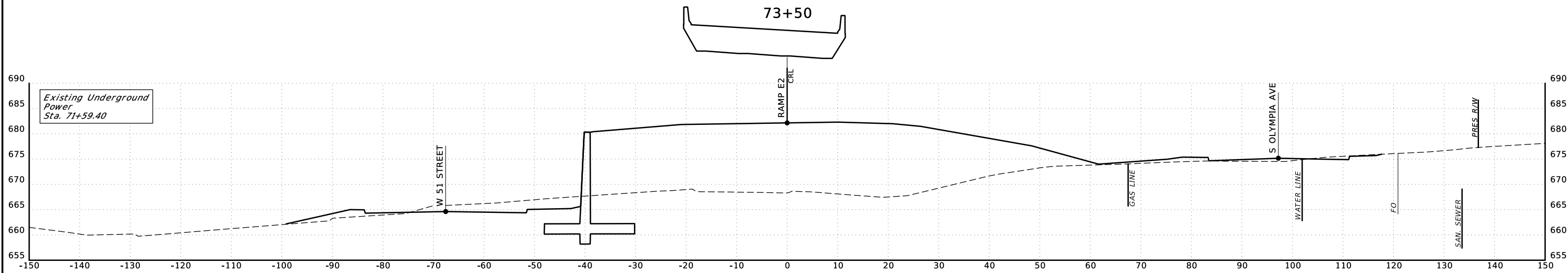

Existing Underground Power Sta. 71+59.40

73+00

RAMP E2 STA. 73+00 TO STA. 73+50

P:\FDB\1650-TUL\CIV\400315_000T_EC2123A_US75_Design-Working\CIV\MicroStation\3378811-CrossSections.dgn

3/4/2021

SCALE: 1"=10'

END AREAS (SF)

PHASE 1 PHASE 2 PHASE 3 PHASE 4 PHASE 5

VOLUMES (CY)

PHASE 1 PHASE 2 PHASE 3 PHASE 4 PHASE 5

P:\FDB\1650-TUL\CIV\400315_000T_EC2123A_US75_Design-Working\CIV\MicroStation\3378811-WP5\3378811-CrossSections.dgn

3/4/2021

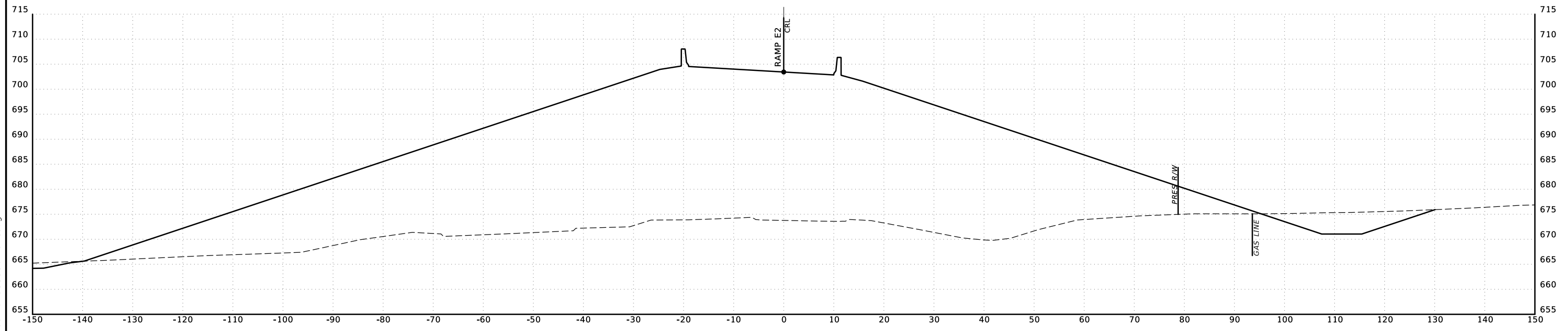

74+50

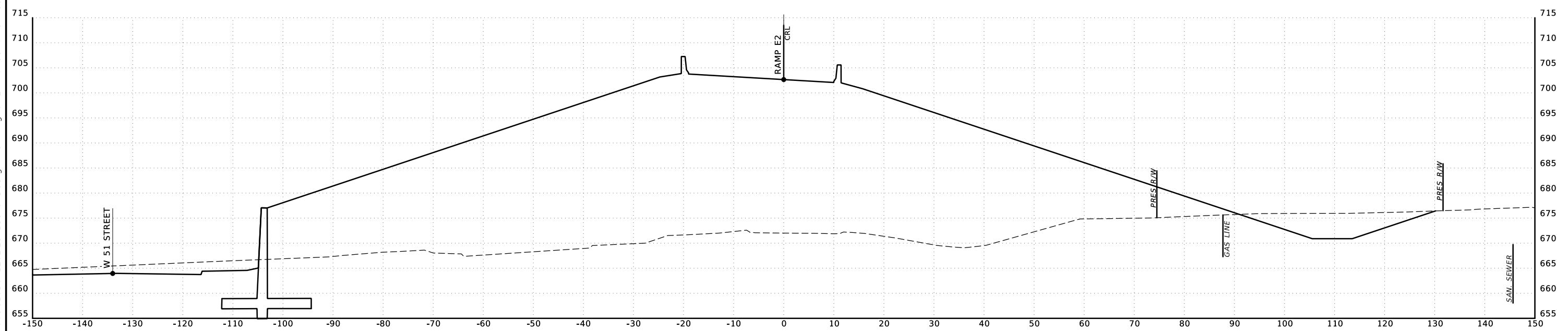

74+00

RAMP E2 STA. 74+00 TO STA. 74+50

SCALE: 1"=10'

END AREAS (SF)

VOLUMES (CY)

PHASE 1

PHASE 2

PHASE 3

PHASE 4

PHASE 5

PHASE 1

PHASE 2

PHASE 3

PHASE 4

PHASE 5

3/4/2021

P:\FDB\1650-TUL\CIV\1400315_000T_EC2123A_US75_Design-Working\CIV\MicroStation\3378811-CrossSections.dgn

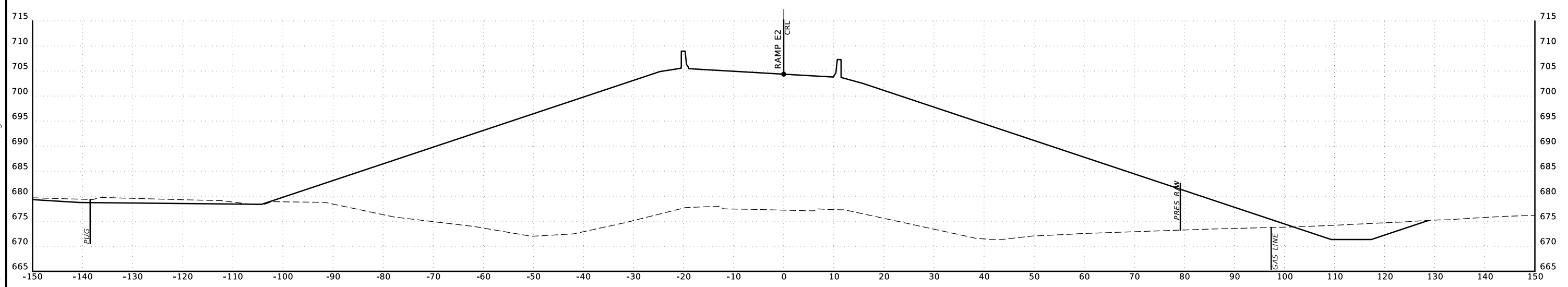

75+50

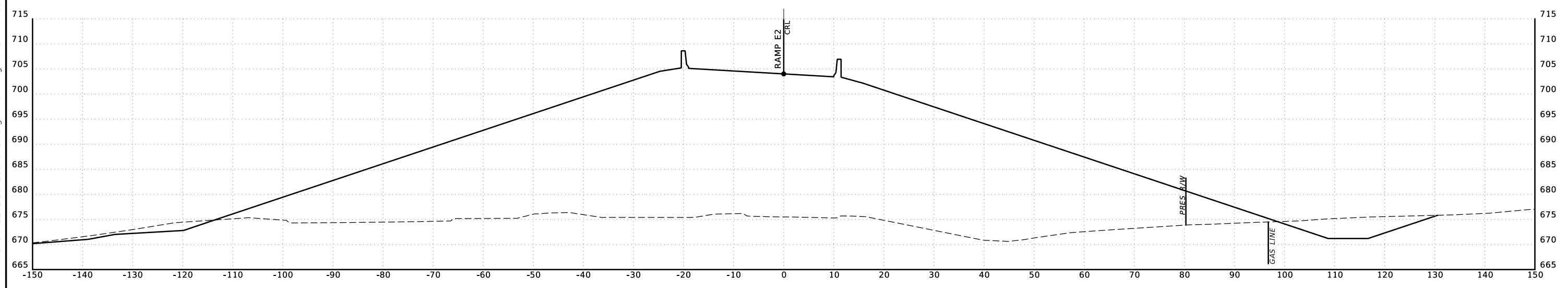

75+00

RAMP E2 STA. 75+00 TO STA. 75+50

SCALE: 1"=10'

END AREAS (SF)

PHASE 1 PHASE 2 PHASE 3 PHASE 4 PHASE 5

VOLUMES (CY)

PHASE 1 PHASE 2 PHASE 3 PHASE 4 PHASE 5

P:\FDB\1650-TUL\CIV\1400315_ODOT_EC2123A_US75_Design-Working\CIV\MicroStation\3378811-CrossSections.dgn

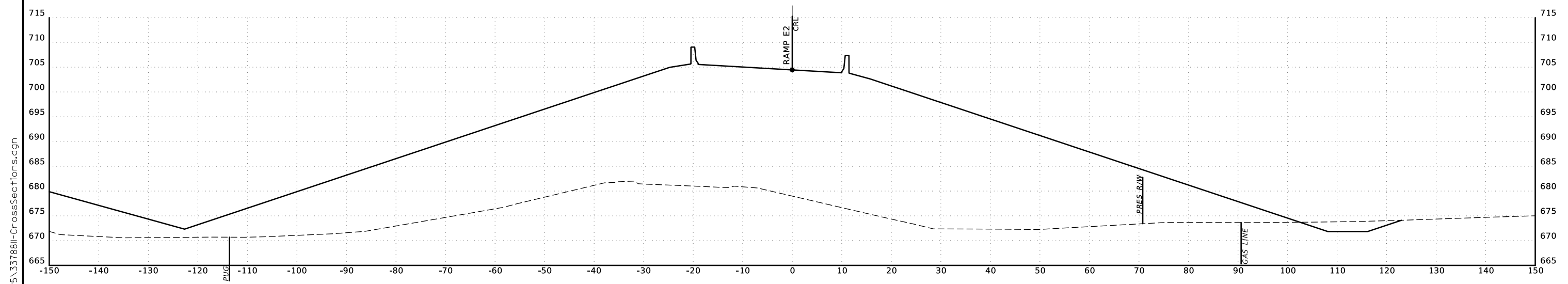

76+50

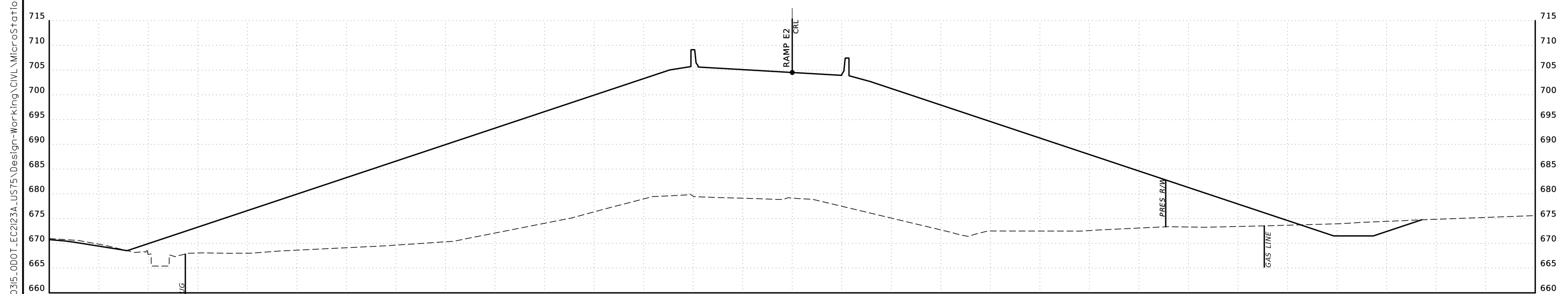

76+00

RAMP E2 STA. 76+00 TO STA. 76+50

SCALE: 1"=10'

END AREAS (SF)

PHASE 1 PHASE 2 PHASE 3 PHASE 4 PHASE 5

VOLUMES (CY)

PHASE 1 PHASE 2 PHASE 3 PHASE 4 PHASE 5

P:\FDB\1650-TUL\CIV\1400315_000T_EC2123A_US75_Design-Working\CIV\MicroStation\3378811-CrossSections.dgn

3/4/2021

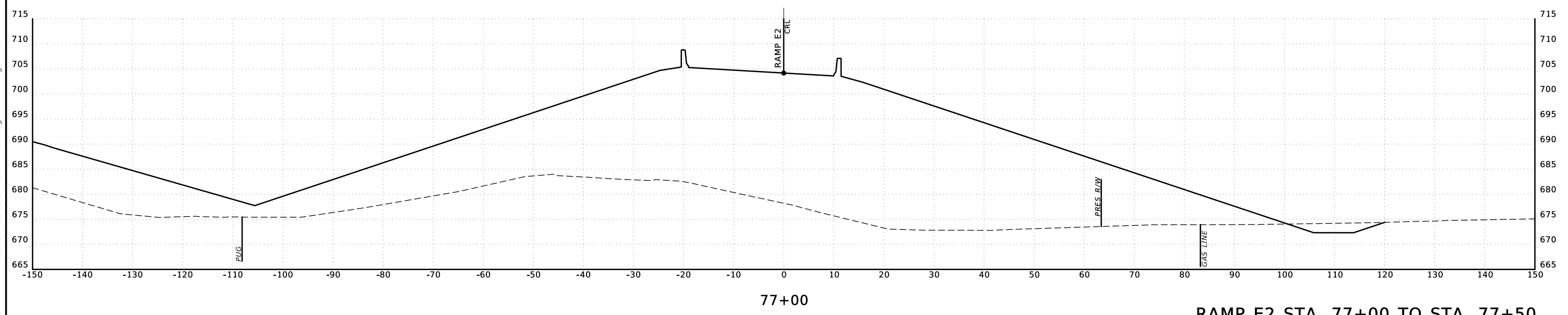
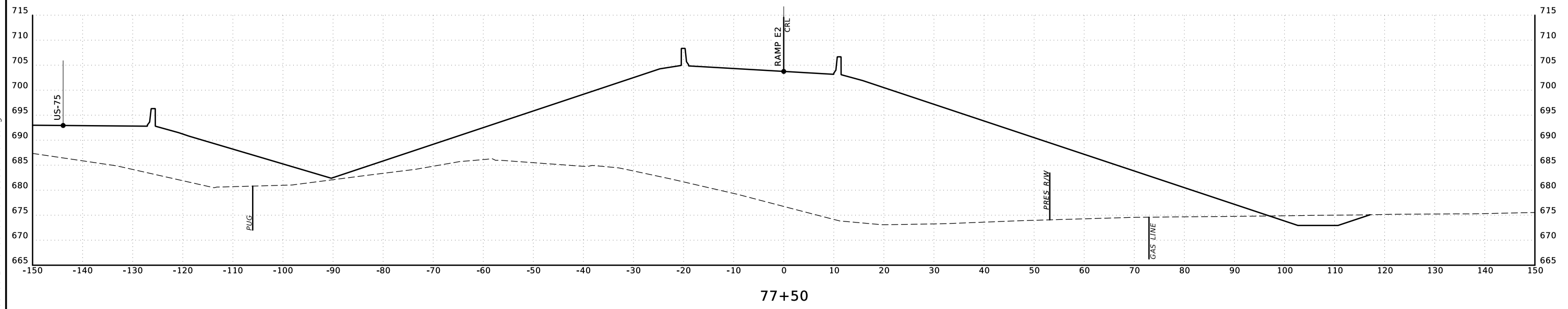

RAMP E2 STA. 77+00 TO STA. 77+50

SCALE: 1"=10'

END AREAS (SF)

VOLUMES (CY)

PHASE 1

PHASE 2

PHASE 3

PHASE 4

PHASE 5

PHASE 1

PHASE 2

PHASE 3

PHASE 4

PHASE 5

3/4/2021

P:\FDB\1650-TUL\CIV\1400315_000T_EC2123A_US75_Design-Working\CIV\MicroStation\3378811-CrossSections.dgn

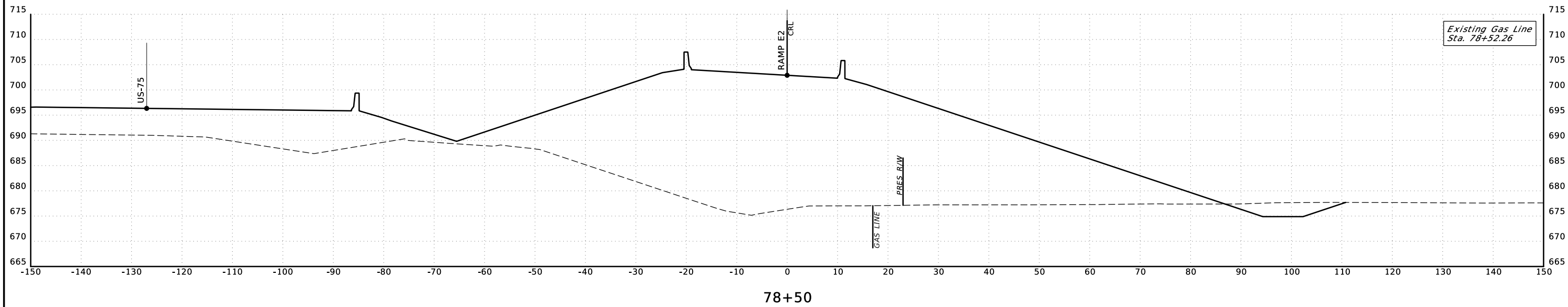

78+50

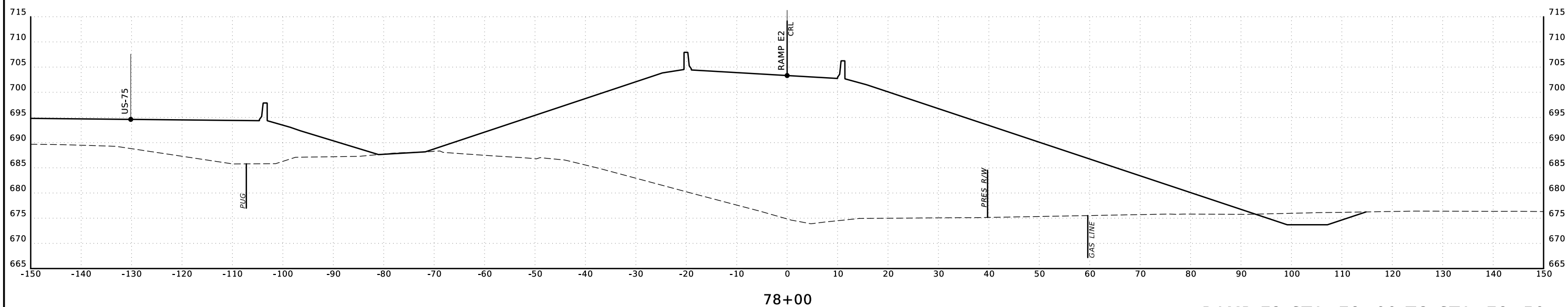

78+00

RAMP E2 STA. 78+00 TO STA. 78+50

SCALE: 1"=10'

END AREAS (SF)

PHASE 1 PHASE 2 PHASE 3 PHASE 4 PHASE 5

VOLUMES (CY)

PHASE 1 PHASE 2 PHASE 3 PHASE 4 PHASE 5

P:\FDB\1650-TUL\CIV\1400315-TUL\CIV\EC2123A_US75\Design-Working\CIV\MicroStation\33788II-CrossSections.dgn

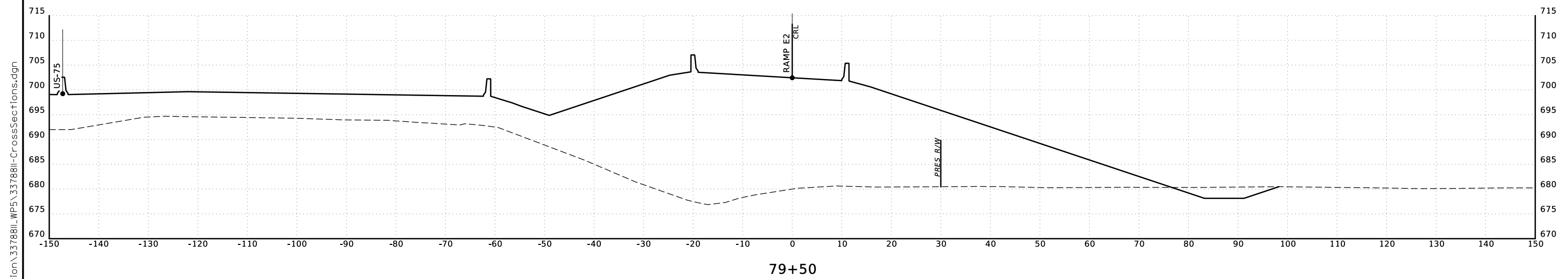

79+50

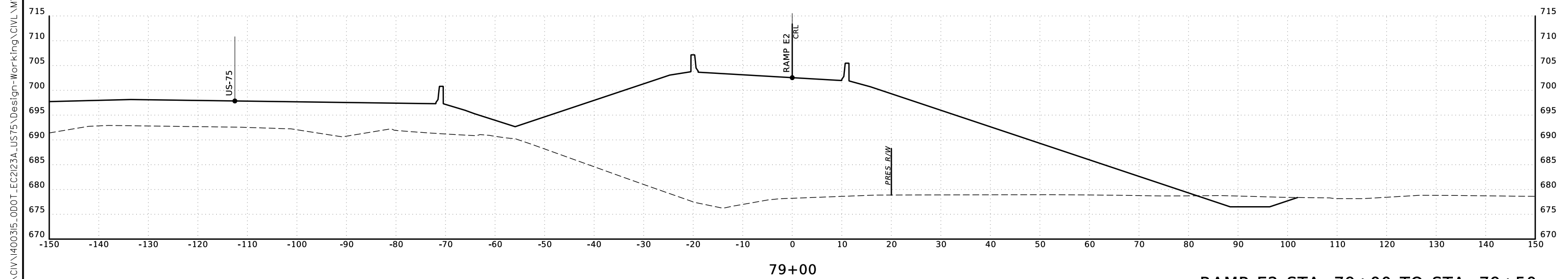

79+00

RAMP E2 STA. 79+00 TO STA. 79+50

SCALE: 1"=10'

3/4/2021

P:\FDB\1650-TUL\CIV\1400315_000T_EC2123A_US75_Design-Working\CIV\MicroStation\3378811-CrossSections.dgn

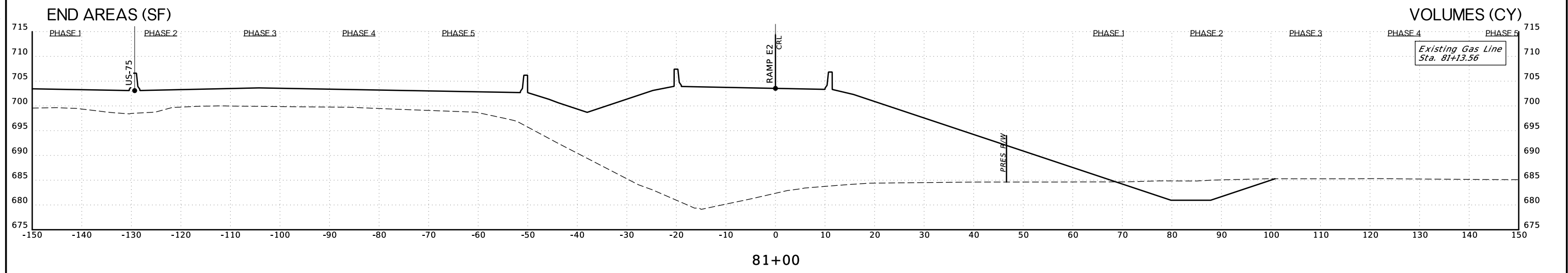

81+00

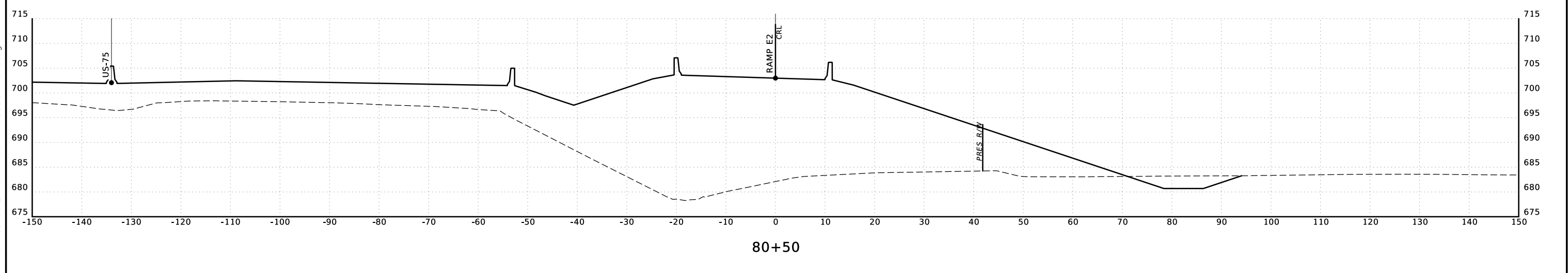

80+50

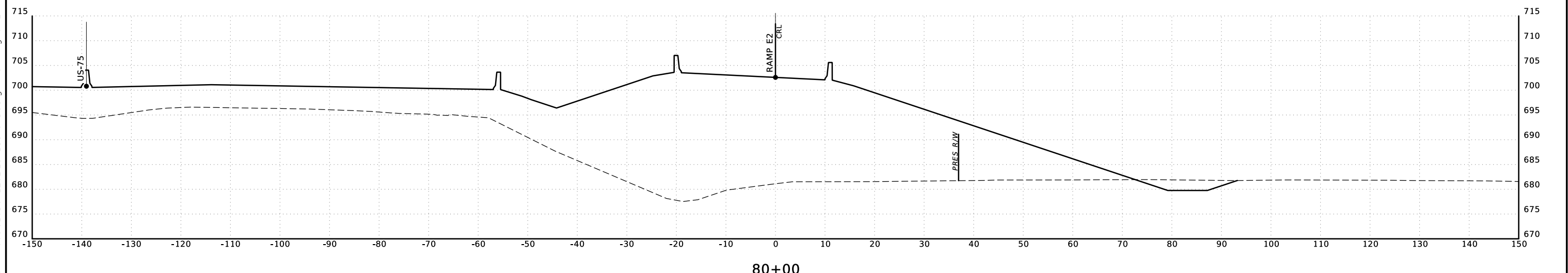

80+00

RAMP E2 STA. 80+00 TO STA. 81+00

END AREAS (SF)

PHASE 1 PHASE 2 PHASE 3 PHASE 4 PHASE 5

VOLUMES (CY)

PHASE 1 PHASE 2 PHASE 3 PHASE 4 PHASE 5

STA. 83+66.05 - END BRIDGE 'J3'
STA. 82+02.35 - BEGIN BRIDGE 'J3'

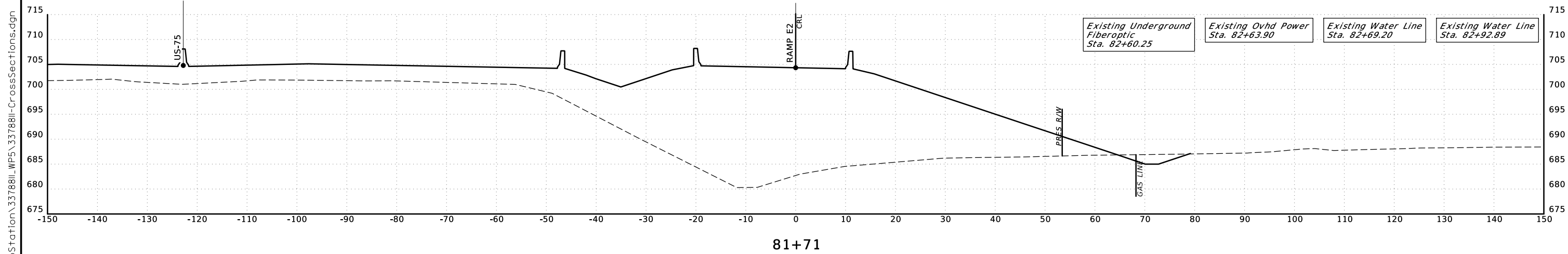

81+71

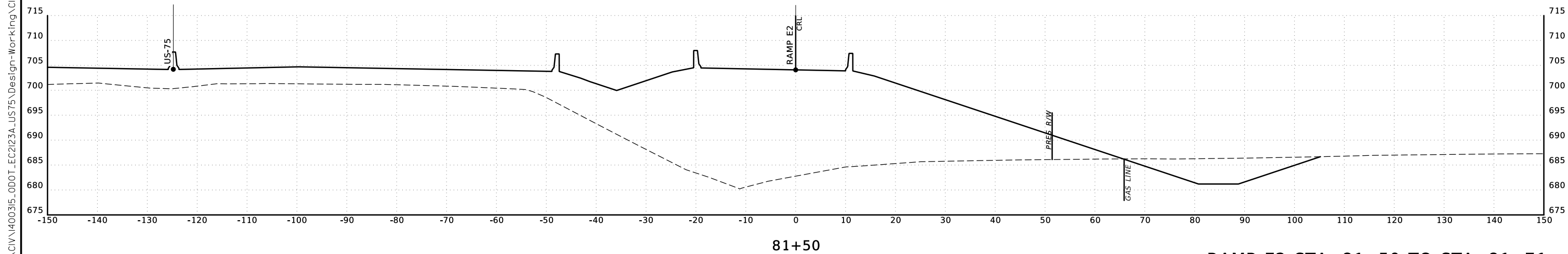

81+50

RAMP E2 STA. 81+50 TO STA. 81+71

SCALE: 1"=10'

P:\FDB\1650-TUL\CIV\400315_000T_EC2123A_US75_Design-Working\CIV\MicroStation\3378811-WP5\3378811-CrossSections.dgn

3/4/2021

END AREAS (SF)

PHASE1 PHASE2 PHASE3 PHASE4 PHASE5

VOLUMES (CY)

PHASE1 PHASE2 PHASE3 PHASE4 PHASE5

STA. 89+75.14 - END BRIDGE 'L'

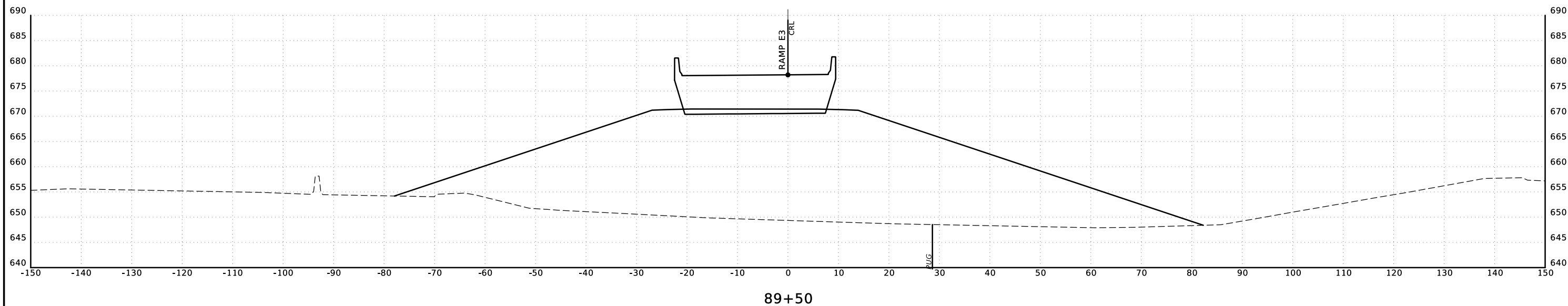

89+50

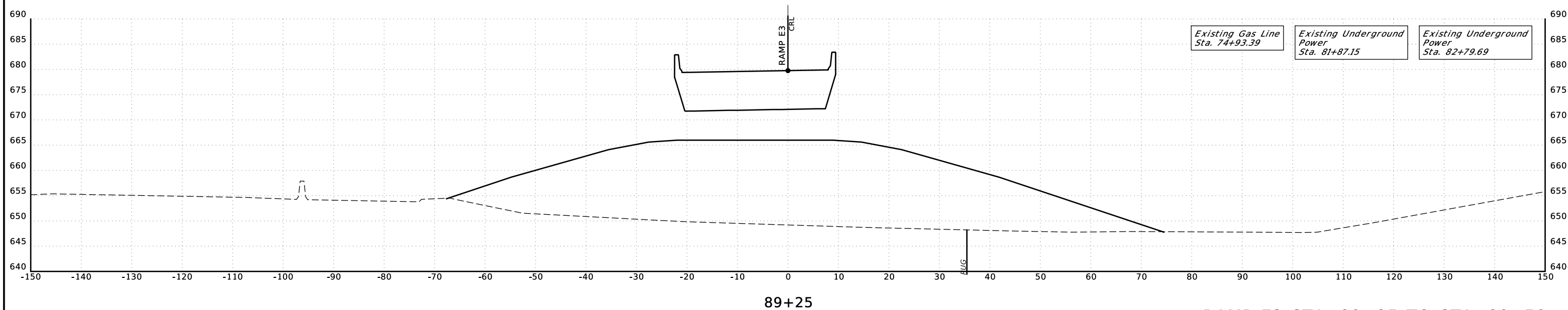

89+25

Existing Gas Line Sta. 74+93.39	Existing Underground Power Sta. 81+87.15	Existing Underground Power Sta. 82+79.69
------------------------------------	--	--

RAMP E3 STA. 89+25 TO STA. 89+50

3/4/2021

P:\FDB\1650-TUL\CIV\1400315_000T_EC2123A_US75_Design-Working\CIV\MicroStation\3378811-CrossSections.dgn

SCALE: 1"=10'

3/4/2021

END AREAS (SF)

PHASE 1 PHASE 2 PHASE 3 PHASE 4 PHASE 5

VOLUMES (CY)

PHASE 1 PHASE 2 PHASE 3 PHASE 4 PHASE 5

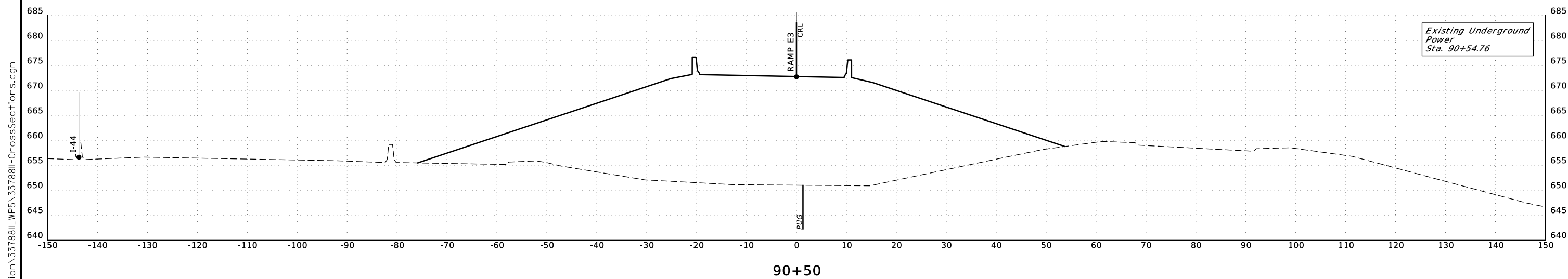

90+50

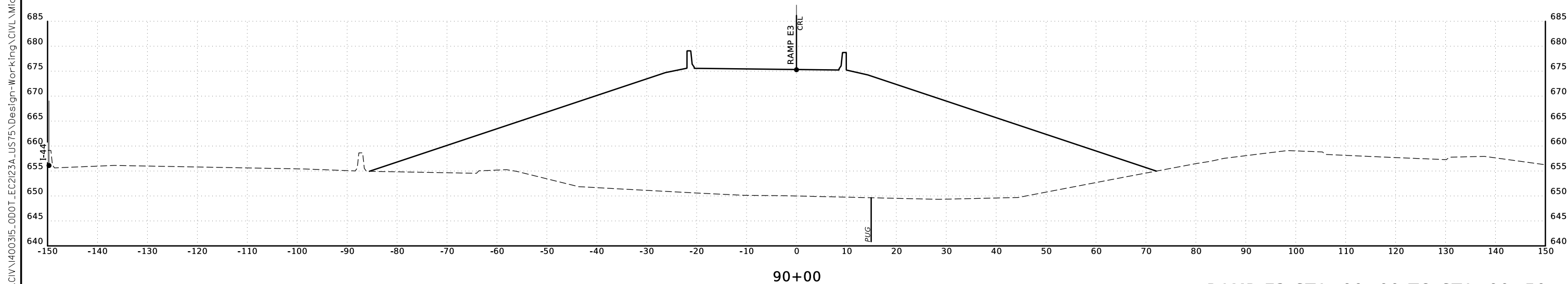

90+00

RAMP E3 STA. 90+00 TO STA. 90+50

P:\FDB\1650-TUL\CIV\1400315_000T_EC2123A_US75_Design-Working\CIV\MicroStation\3378811-CrossSections.dgn

SCALE: 1"=10'

3/4/2021

END AREAS (SF)

PHASE 1 PHASE 2 PHASE 3 PHASE 4 PHASE 5

VOLUMES (CY)

PHASE 1 PHASE 2 PHASE 3 PHASE 4 PHASE 5

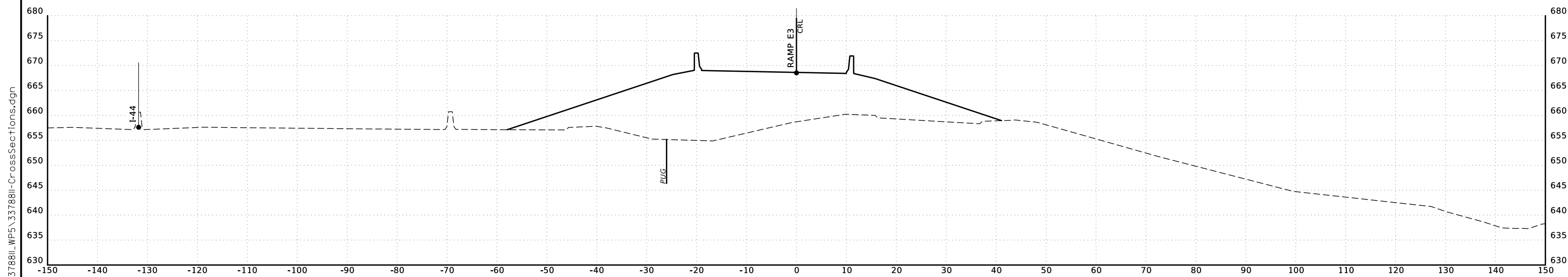

91+50

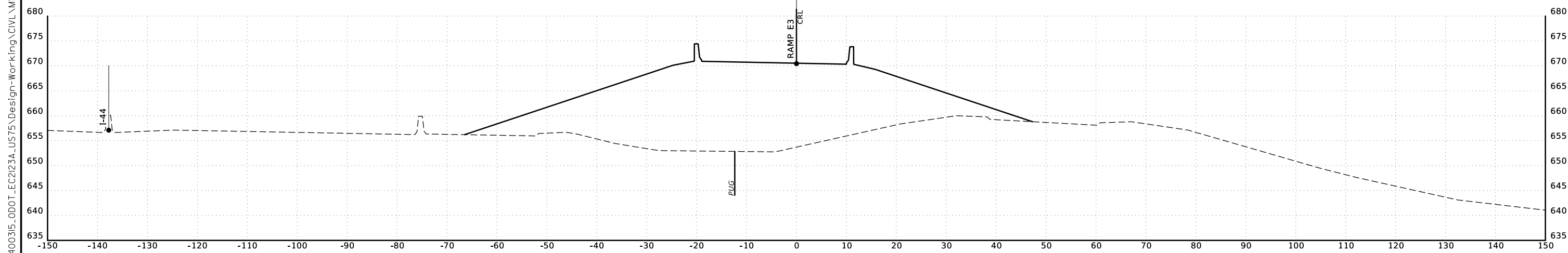

91+00

RAMP E3 STA. 91+00 TO STA. 91+50

P:\FDB\1650-TUL\CIV\1400315_000T_EC2123A_US75_Design-Working\CIV\MicroStation\33788II-CrossSections.dgn

SCALE: 1"=10'

3/4/2021

P:\FDB\1650-TUL\CIV\400315_000T_EC2123A_US75_Design-Working\CIV\MicroStation\3378811-CrossSections.dgn

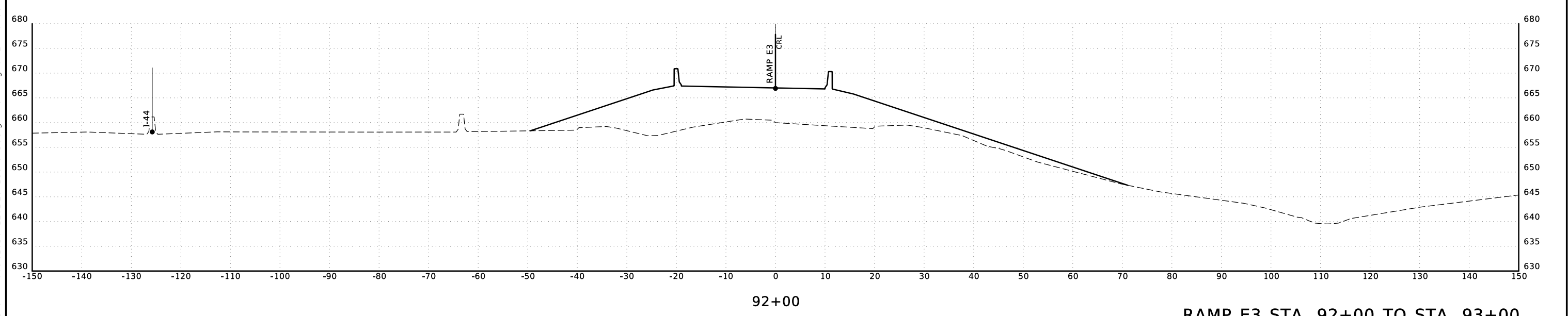
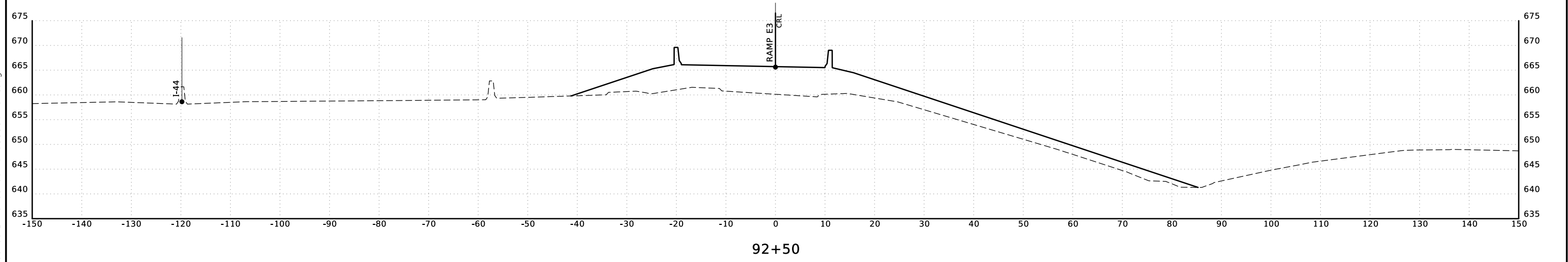
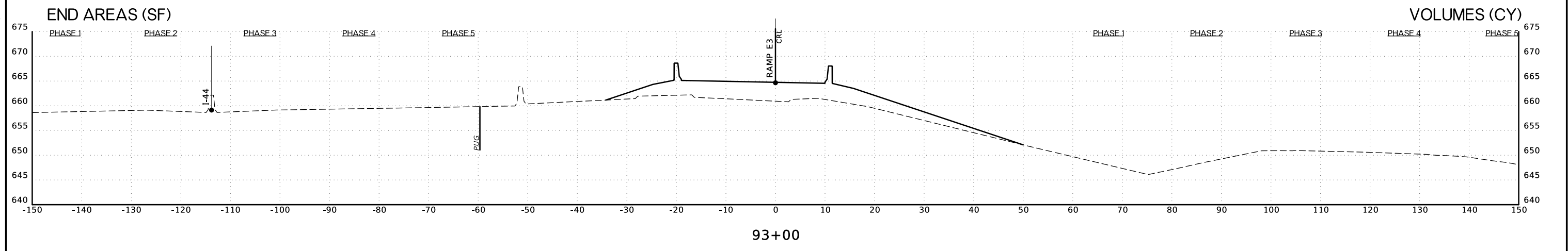

RAMP E3 STA. 92+00 TO STA. 93+00

SCALE: 1"=10'

3/4/2021

END AREAS (SF)

PHASE 1 PHASE 2 PHASE 3 PHASE 4 PHASE 5

VOLUMES (CY)

PHASE 1 PHASE 2 PHASE 3 PHASE 4 PHASE 5

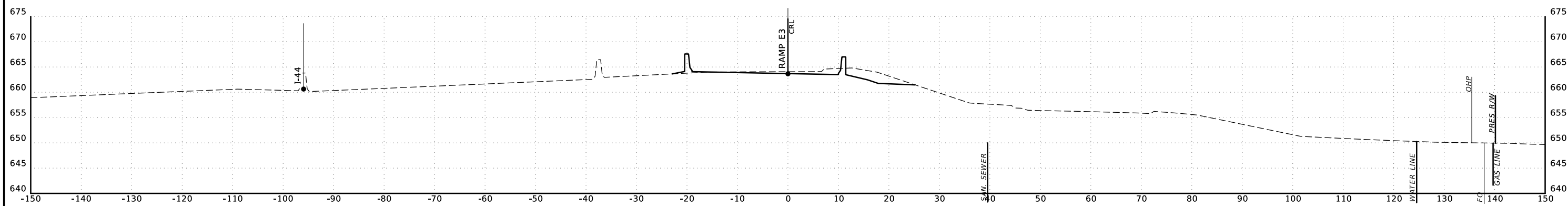

94+50

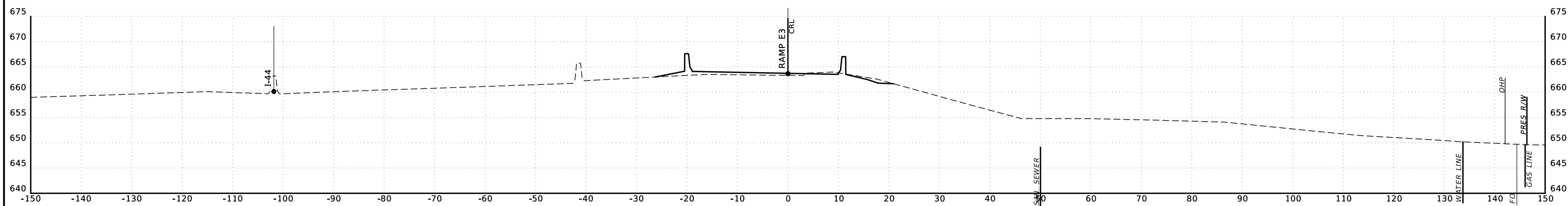

94+00

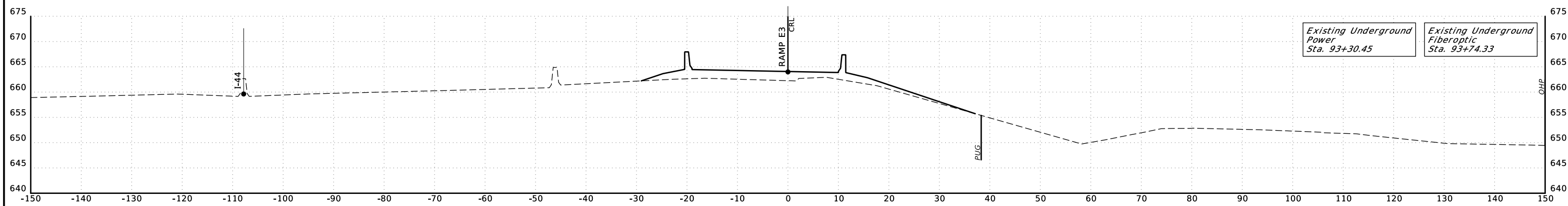

93+50

RAMP E3 STA. 93+50 TO STA. 94+50

P:\FDB\1650-TUL\CIV\1400315_000T_EC2123A_US75_Design-Working\CIV\MicroStation\3378811-WP5\3378811-CrossSections.dgn

SCALE: 1"=10'

3/4/2021

END AREAS (SF)

PHASE 1 PHASE 2 PHASE 3 PHASE 4 PHASE 5

VOLUMES (CY)

PHASE 1 PHASE 2 PHASE 3 PHASE 4 PHASE 5

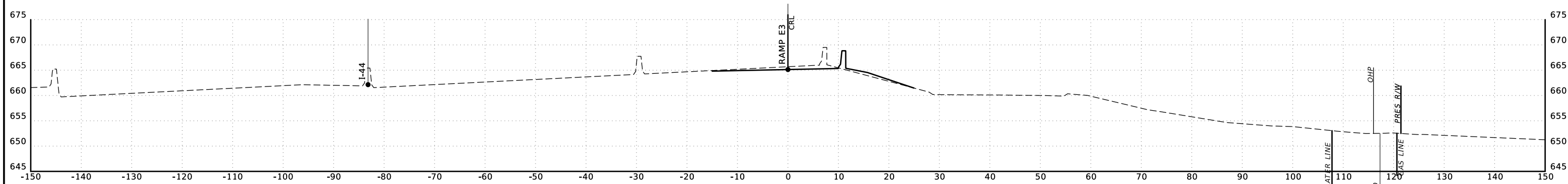

96+00

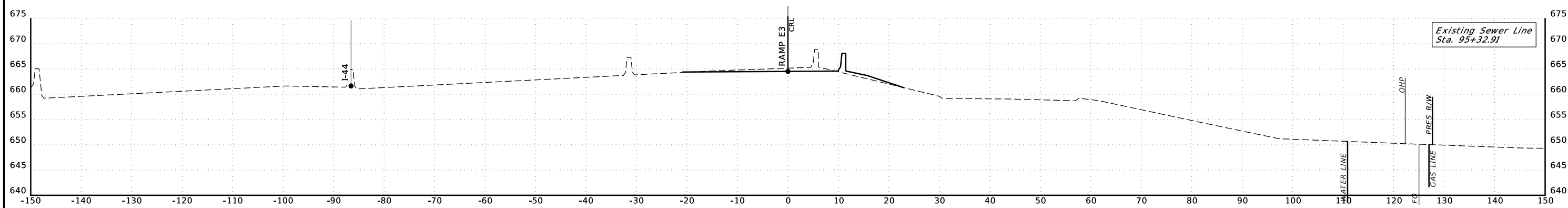

95+50

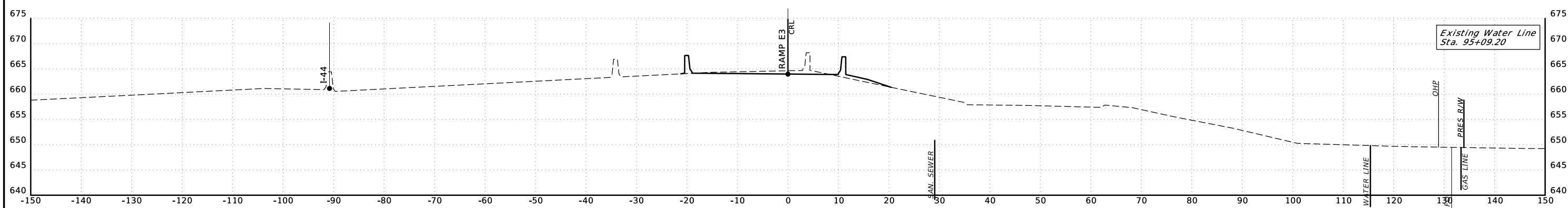

95+00

RAMP E3 STA. 95+00 TO STA. 96+00

P:\FDB\1650-TUL\CIV\1400315_000T_EC2123A_US75_Design-Working\CIV\MicroStation\3378811-WP5\3378811-CrossSections.dgn

SCALE: 1"=10'

3/4/2021

END AREAS (SF)

VOLUMES (CY)

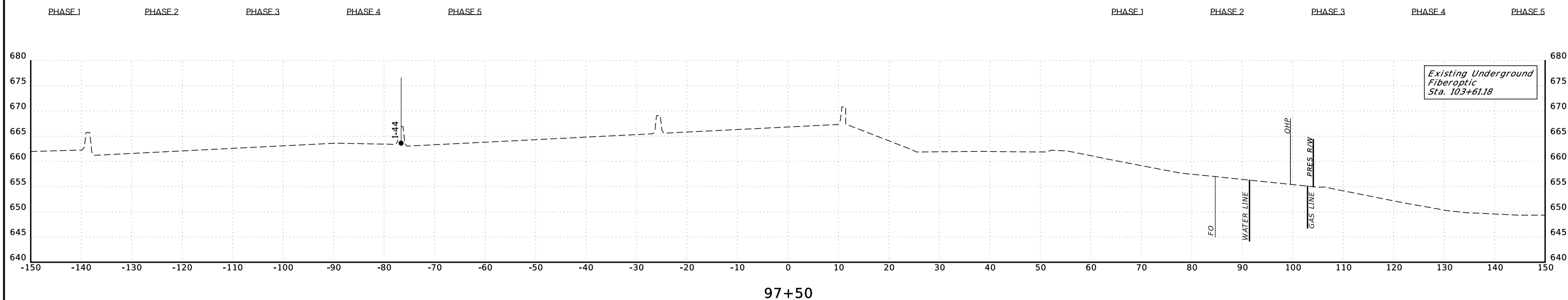

STA. 97+00.18 - END RAMP E3

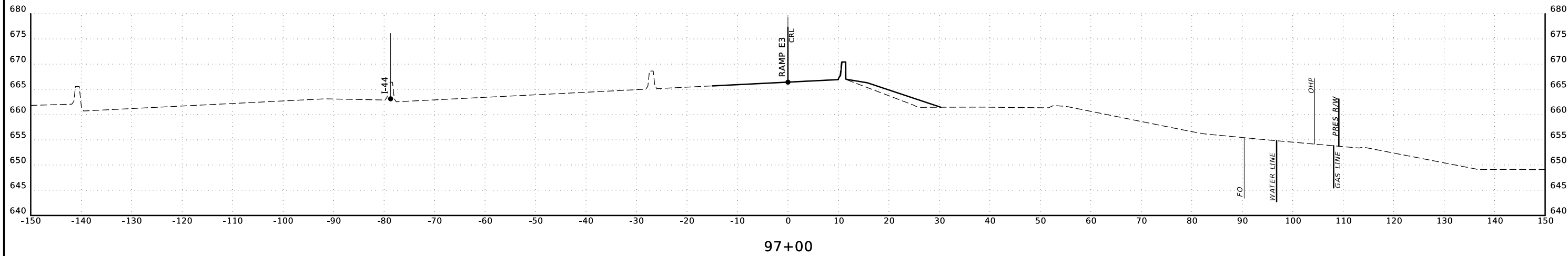

96+50

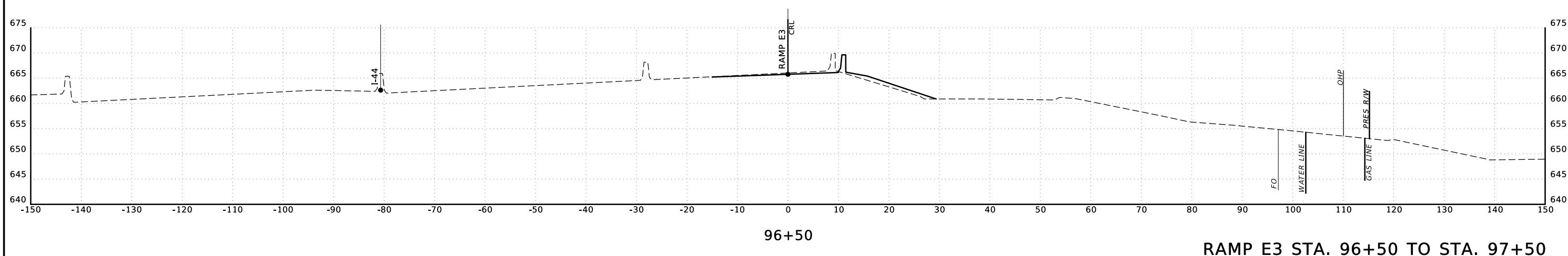

RAMP E3 STA. 96+50 TO STA. 97+50

P:\FDB\1650-TUL\CIV\400315_000T_EC2123A_US75_Design-Working\CIV\MicroStation\3378811-WP5\3378811-CrossSections.dgn

SCALE: 1"=10'

3/4/2021

END AREAS (SF)

PHASE 1 PHASE 2 PHASE 3 PHASE 4 PHASE 5

VOLUMES (CY)

PHASE 1 PHASE 2 PHASE 3 PHASE 4 PHASE 5

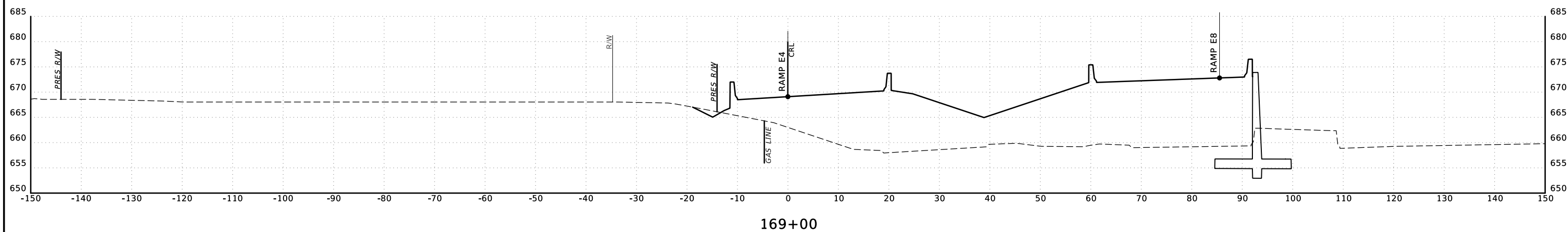

169+00

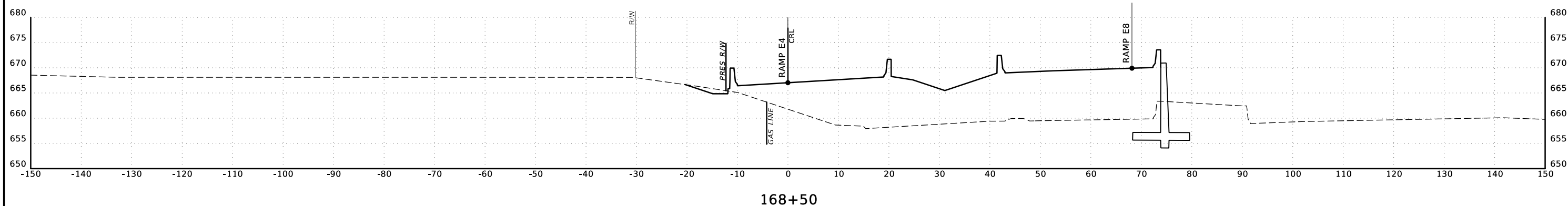

168+50

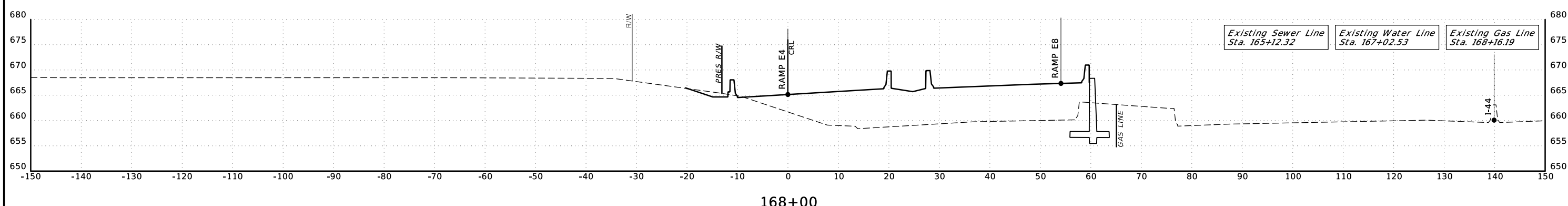

168+00

STA. 167+95.08 - BEGIN RAMP E4

RAMP E4 STA. 168+00 TO STA. 169+00

P:\FDB\1650-TUL\CIV\400315_000T_EC2123A_US75_Design-Working\CIV\MicroStation\3378811-WP5\3378811-CrossSections.dgn

END AREAS (SF)

PHASE 1 PHASE 2 PHASE 3 PHASE 4 PHASE 5

VOLUMES (CY)

PHASE 1 PHASE 2 PHASE 3 PHASE 4 PHASE 5

3/4/2021

P:\FDB\1650-TUL\CIV\1400315_000T_EC2123A_US75_Design-Working\CIVL\MicroStation\3378811-CrossSections.dgn

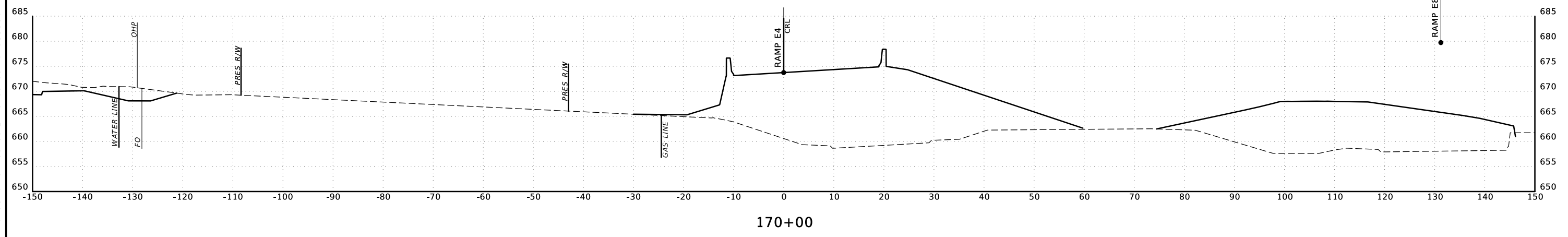

170+00

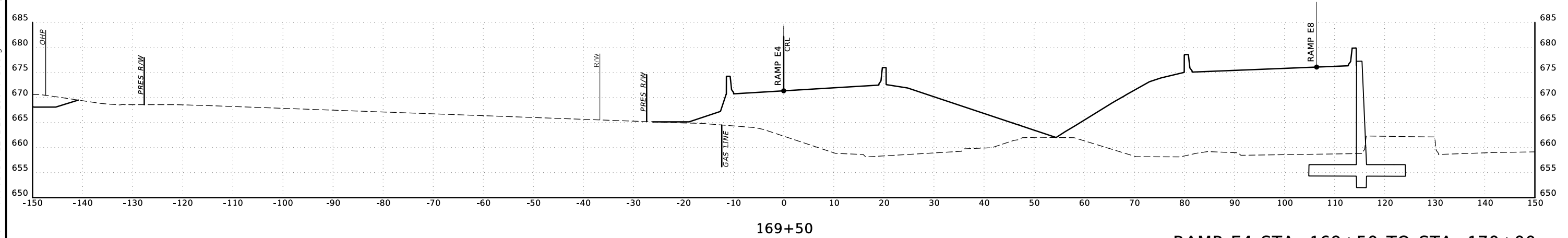

169+50

RAMP E4 STA. 169+50 TO STA. 170+00

SCALE: 1"=10'

END AREAS (SF)

PHASE 1 PHASE 2 PHASE 3 PHASE 4 PHASE 5

VOLUMES (CY)

PHASE 1 PHASE 2 PHASE 3 PHASE 4 PHASE 5

3/4/2021

P:\FDB\1650-TUL\CIV\1400315_000T_EC2123A_US75_Design-Working\CIVL\MicroStation\3378811-WP5\3378811-CrossSections.dgn

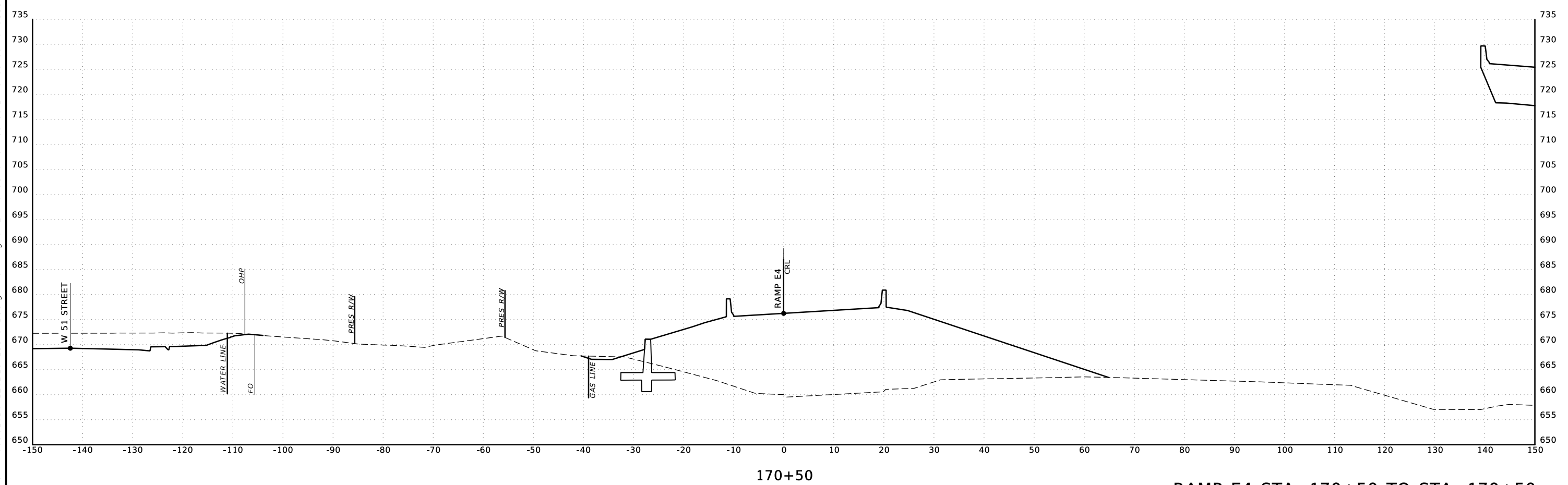

170+50

RAMP E4 STA. 170+50 TO STA. 170+50

SCALE: 1"=10'

3/4/2021

END AREAS (SF)

PHASE 1 PHASE 2 PHASE 3 PHASE 4 PHASE 5

VOLUMES (CY)

PHASE 1 PHASE 2 PHASE 3 PHASE 4 PHASE 5

STA. 171+47.00 - BEGIN BRIDGE 'M'

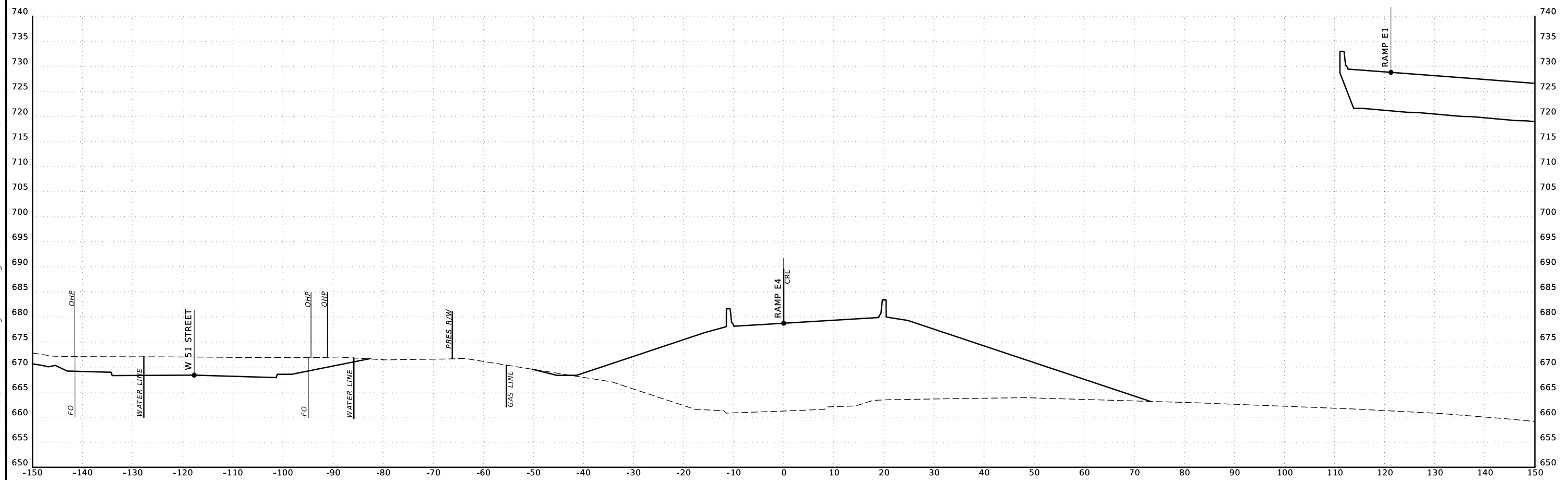

171+00

RAMP E4 STA. 171+00 TO STA. 171+00

P:\FDB\1650-TUL\CIV\1400315_000T_EC2123A_US75_Design-Working\CIV\MicroStation\3378811-WP5\3378811-CrossSections.dgn

SCALE: 1"=10'

END AREAS (SF)

PHASE 1 PHASE 2 PHASE 3 PHASE 4 PHASE 5

VOLUMES (CY)

PHASE 1 PHASE 2 PHASE 3 PHASE 4 PHASE 5

3/4/2021

P:\FDB\1650-TUL\CIV\1400315_000T_EC2123A_US75_Design-Working\CIVL\MicroStation\3378811-WP5\3378811-CrossSections.dgn

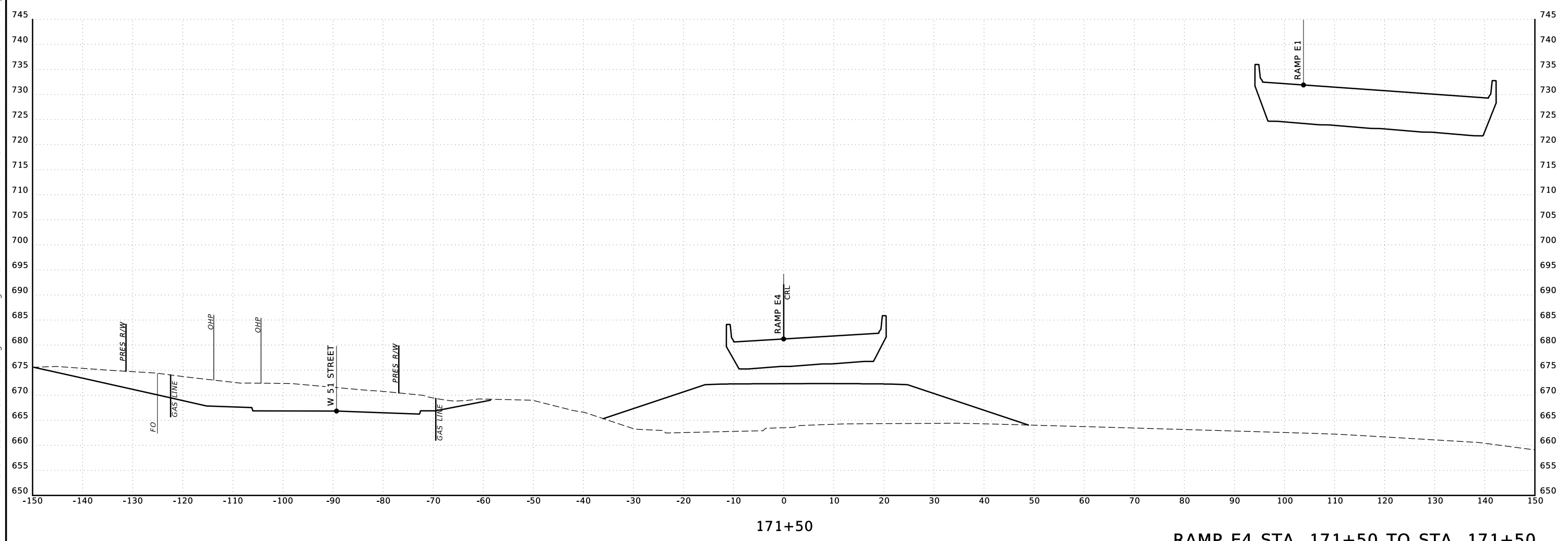

RAMP E4 STA. 171+50 TO STA. 171+50

SCALE: 1"=10'

END AREAS (SF)

PHASE 1 PHASE 2 PHASE 3 PHASE 4 PHASE 5

VOLUMES (CY)

PHASE 1 PHASE 2 PHASE 3 PHASE 4 PHASE 5

3/4/2021

P:\FDB\1650-TUL\CIV\1400315_000T_EC2123A_US75_Design-Working\CIV\MicroStation\3378811-WP5\3378811-CrossSections.dgn

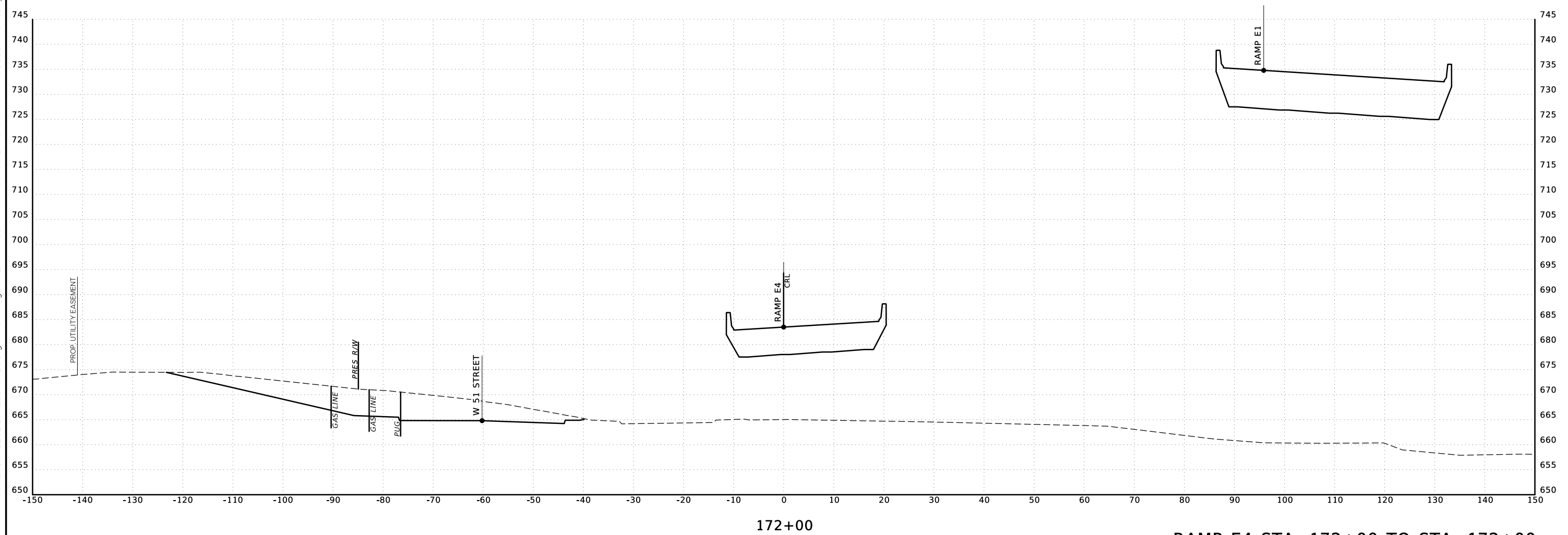

172+00

RAMP E4 STA. 172+00 TO STA. 172+00

SCALE: 1"=10'

END AREAS (SF)

PHASE 1 PHASE 2 PHASE 3 PHASE 4 PHASE 5

VOLUMES (CY)

PHASE 1 PHASE 2 PHASE 3 PHASE 4 PHASE 5

3/4/2021

P:\FDB\1650-TUL\CIV\1400315_000T_EC2123A_US75_Design-Working\CIV\MicroStation\3378811-WP5\3378811-CrossSections.dgn

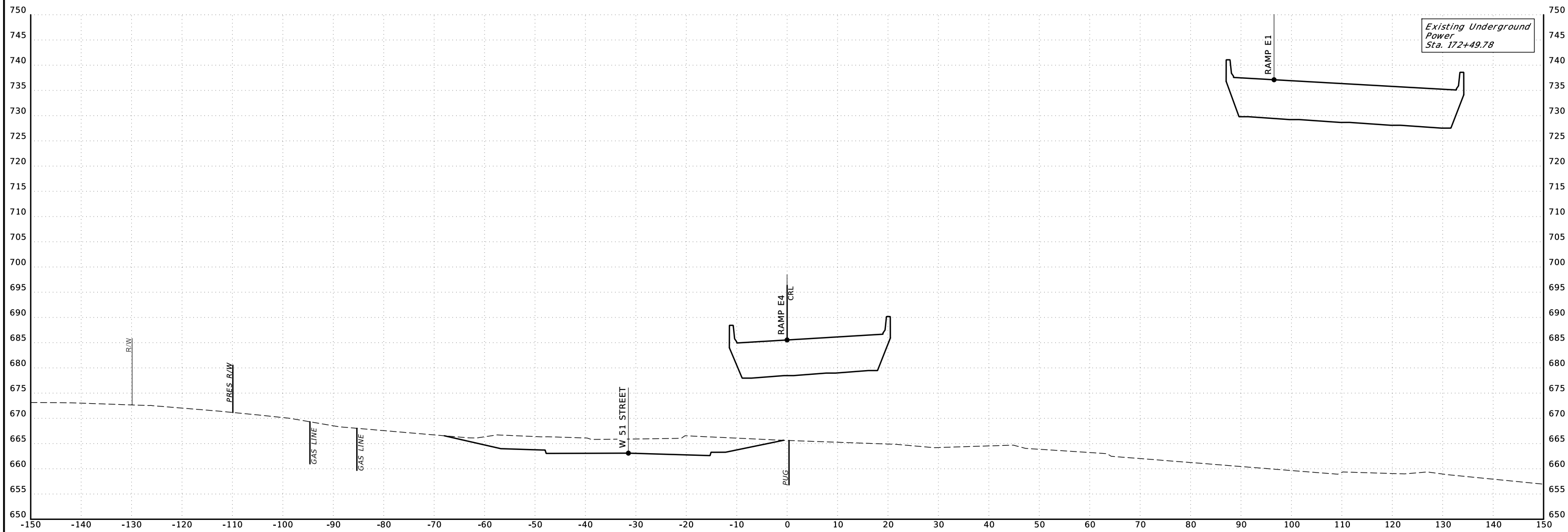

172+50

RAMP E4 STA. 172+50 TO STA. 172+50

SCALE: 1"=10'

R/W UTILITY MEETING

MARCH 2021

END AREAS (SF)

PHASE 1 PHASE 2 PHASE 3 PHASE 4 PHASE 5

VOLUMES (CY)

PHASE 1 PHASE 2 PHASE 3 PHASE 4 PHASE 5

3/4/2021

P:\FDB\1650-TUL\CIV\1400315_US75_Design-Working\CIV\MicroStation\3378811-WP5\3378811-CrossSections.dgn

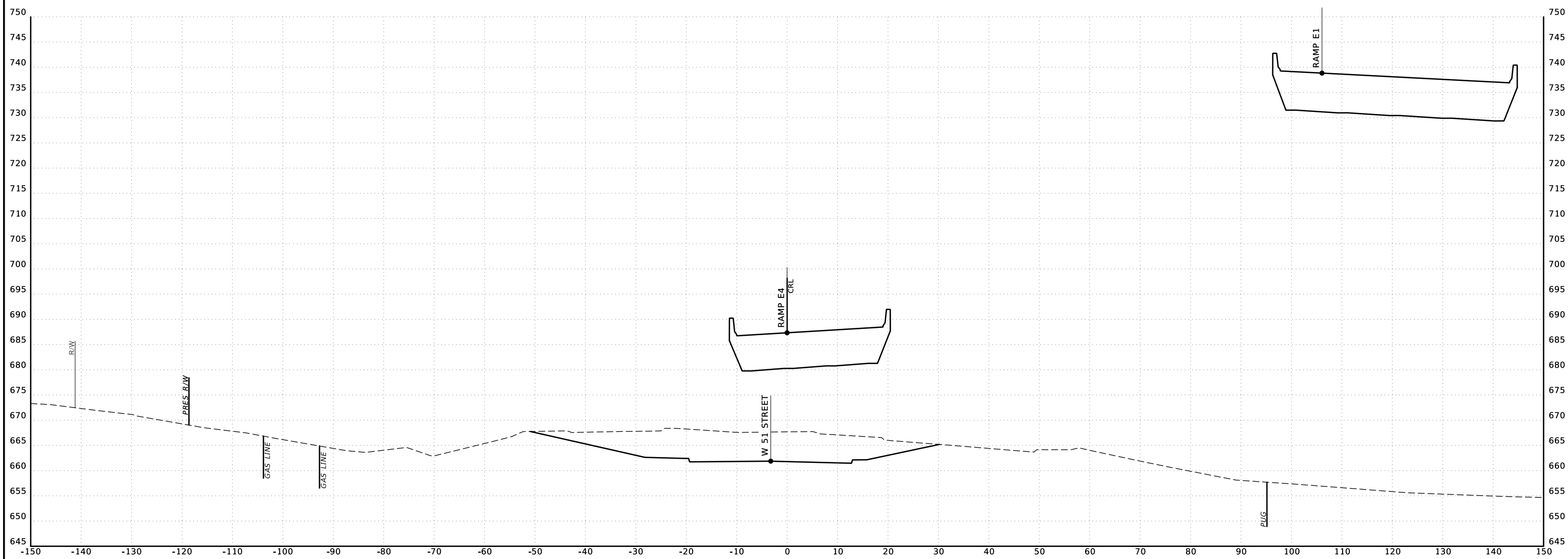

173+00

RAMP E4 STA. 173+00 TO STA. 173+00

SCALE: 1"=10'

END AREAS (SF)

PHASE 1 PHASE 2 PHASE 3 PHASE 4 PHASE 5

VOLUMES (CY)

PHASE 1 PHASE 2 PHASE 3 PHASE 4 PHASE 5

3/4/2021

P:\FDB\1650-TUL\CIV\1400315_000T_EC2123A_US75_Design-Working\CIV\MicroStation\3378811-WP5\3378811-CrossSections.dgn

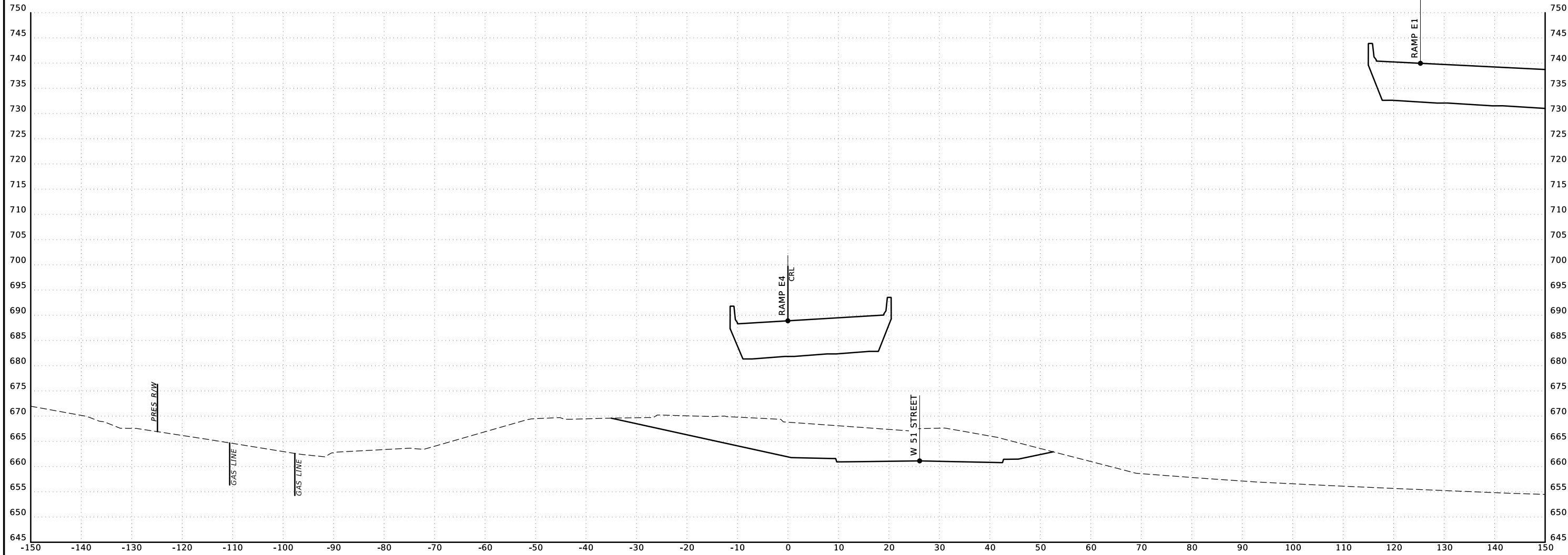

173+50

RAMP E4 STA. 173+50 TO STA. 173+50

SCALE: 1"=10'

3/4/2021

END AREAS (SF)

PHASE 1 PHASE 2 PHASE 3 PHASE 4 PHASE 5

VOLUMES (CY)

PHASE 1 PHASE 2 PHASE 3 PHASE 4 PHASE 5

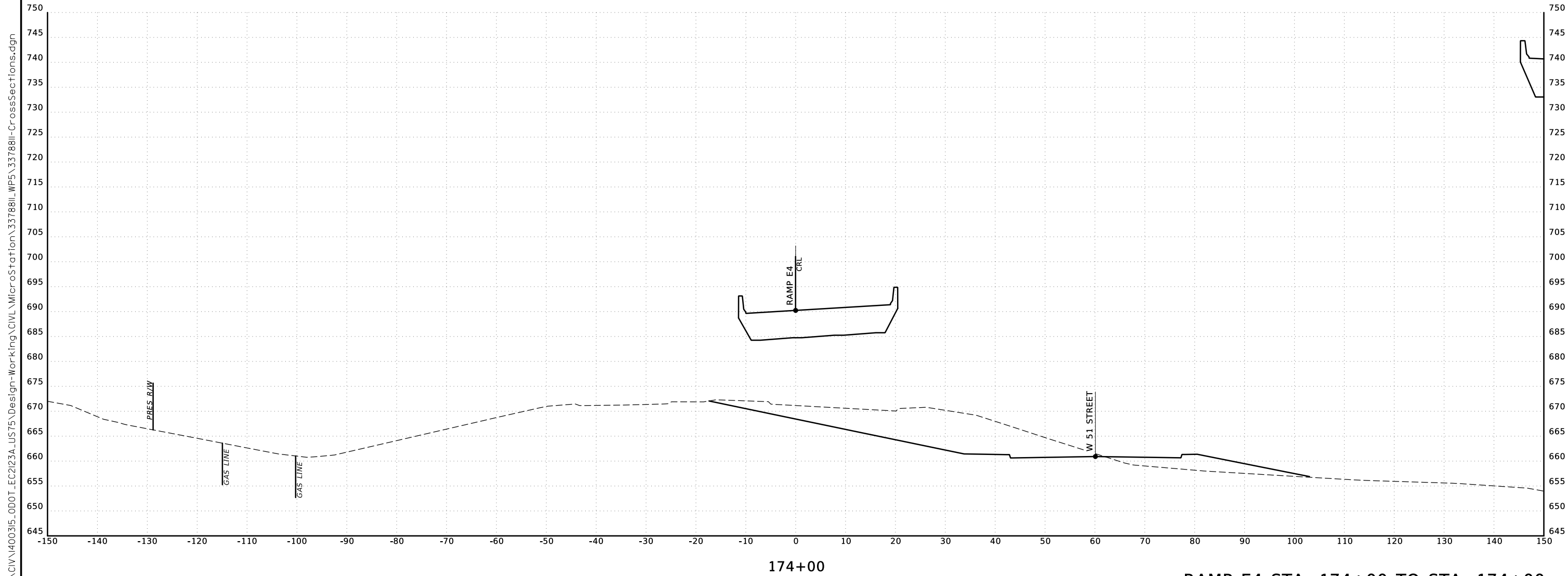

RAMP E4 STA. 174+00 TO STA. 174+00

P:\FDB\1650-TUL\CIV\1400315_000T_EC2123A_US75_Design-Working\CIV\MicroStation\3378811-WP5\3378811-CrossSections.dgn

SCALE: 1"=10'

END AREAS (SF)

PHASE 1 PHASE 2 PHASE 3 PHASE 4 PHASE 5

VOLUMES (CY)

PHASE 1 PHASE 2 PHASE 3 PHASE 4 PHASE 5

STA. 175+11.43 - END BRIDGE 'M'

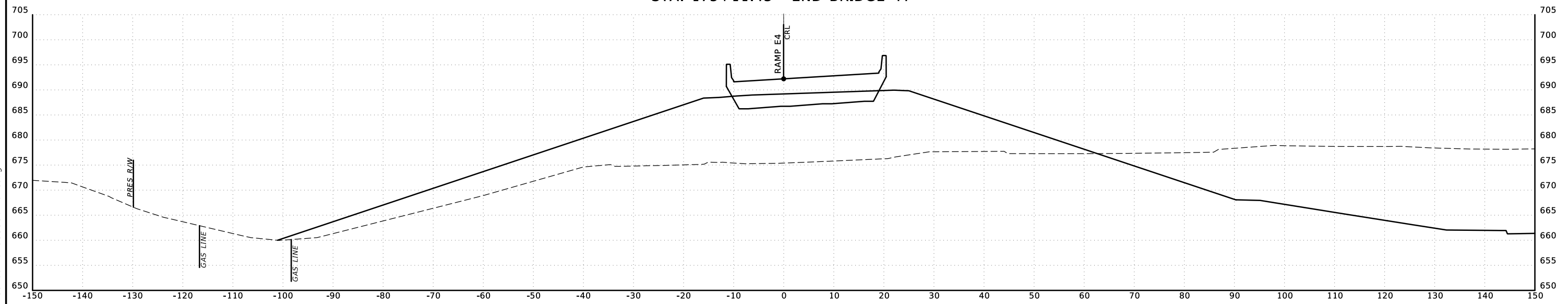

175+00

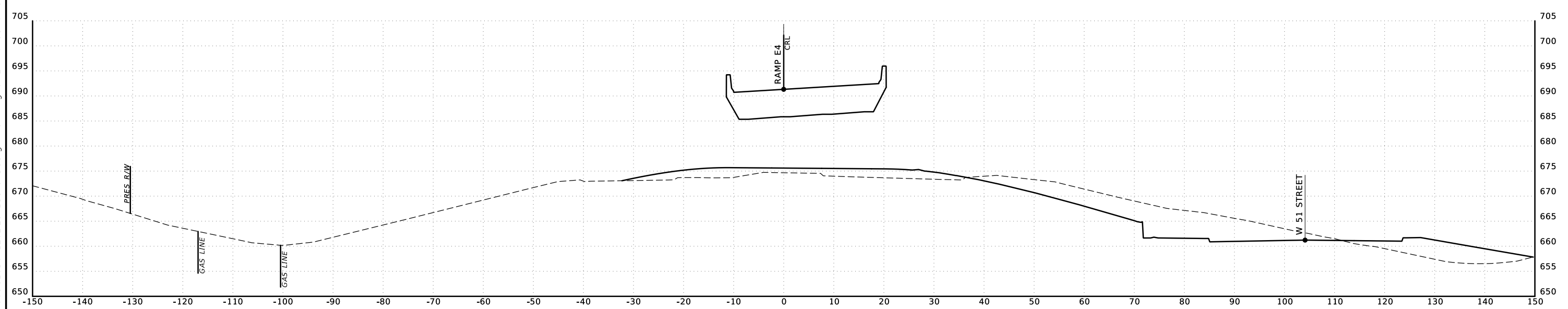

174+50

RAMP E4 STA. 174+50 TO STA. 175+00

P:\FDB\1650-TUL\CIV\1400315_000T_EC2123A_US75_Design-Working\CIV\MicroStation\3378811-CrossSections.dgn

3/4/2021

SCALE: 1"=10'

3/4/2021

END AREAS (SF)

PHASE 1 PHASE 2 PHASE 3 PHASE 4 PHASE 5

VOLUMES (CY)

PHASE 1 PHASE 2 PHASE 3 PHASE 4 PHASE 5

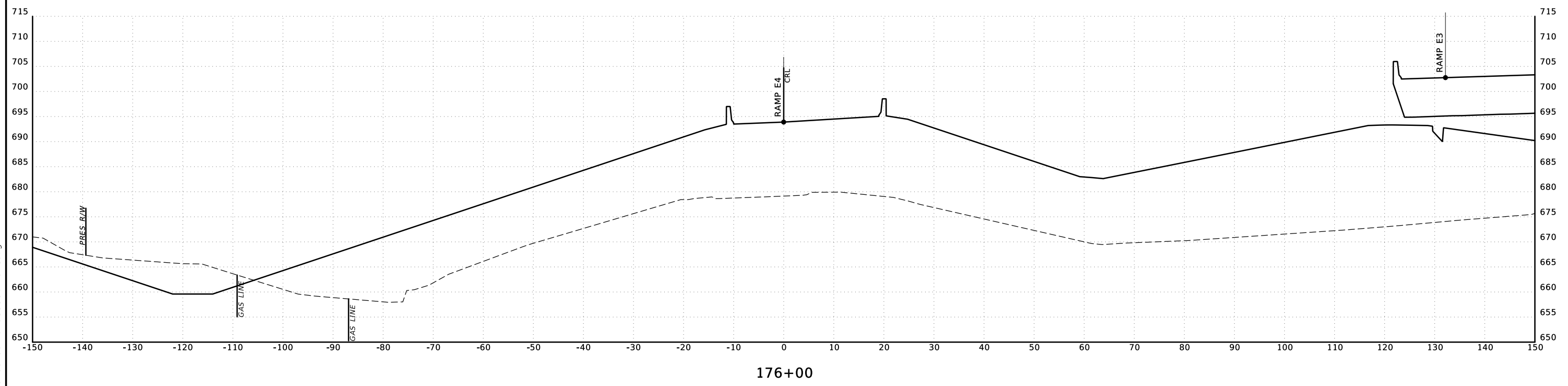

176+00

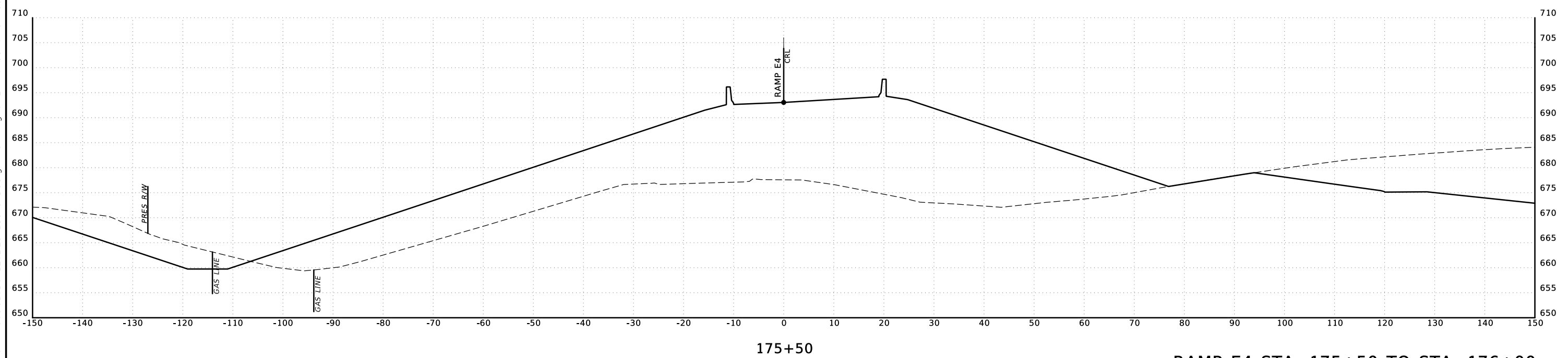

175+50

RAMP E4 STA. 175+50 TO STA. 176+00

P:\FDB\1650-TUL\CIV\1400315_000T_EC2123A_US75_Design-Working\CIV\MicroStation\3378811-WP5\3378811-CrossSections.dgn

SCALE: 1"=10'

P:\FDB\1650-TUL\CIV\1400315_000T_EC2123A_US75_Design-Working\CIV\MicroStation\3378811-WP5\3378811-CrossSections.dgn

END AREAS (SF)

PHASE 1 PHASE 2 PHASE 3 PHASE 4 PHASE 5

VOLUMES (CY)

PHASE 1 PHASE 2 PHASE 3 PHASE 4 PHASE 5

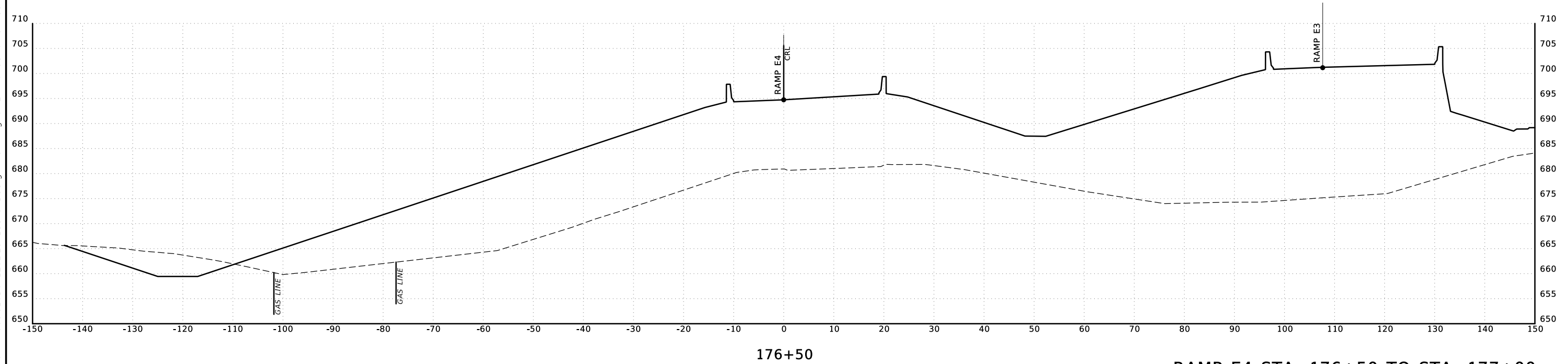
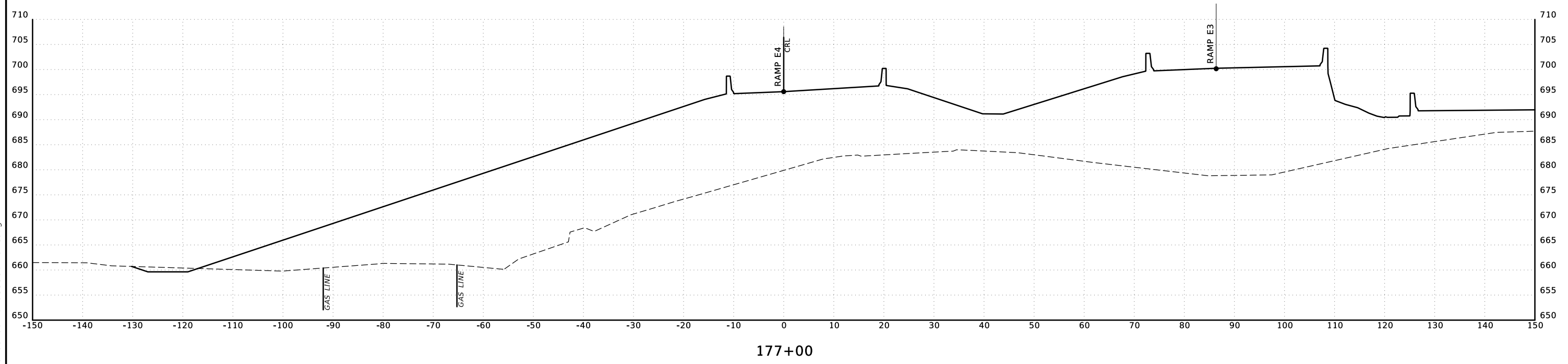

RAMP E4 STA. 176+50 TO STA. 177+00

SCALE: 1"=10'

3/4/2021

END AREAS (SF)

VOLUMES (CY)

PHASE 1 PHASE 2 PHASE 3 PHASE 4 PHASE 5 PHASE 1 PHASE 2 PHASE 3 PHASE 4 PHASE 5

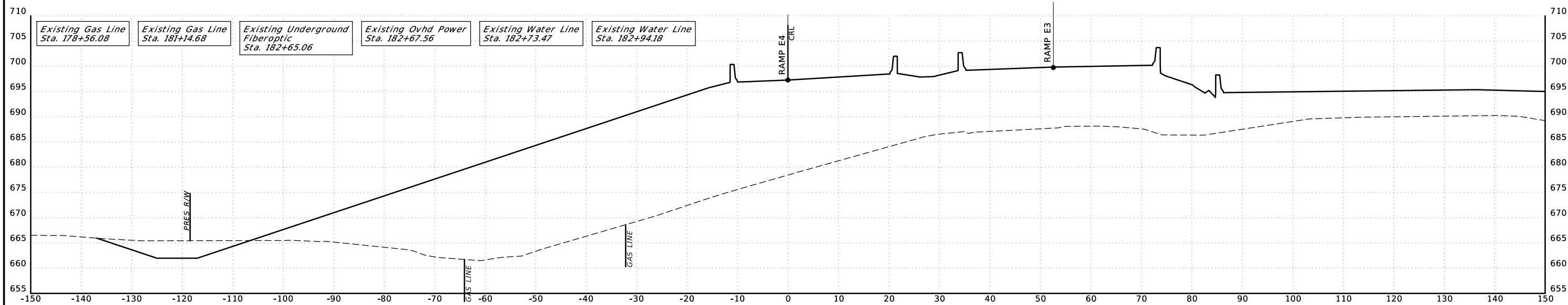

178+00

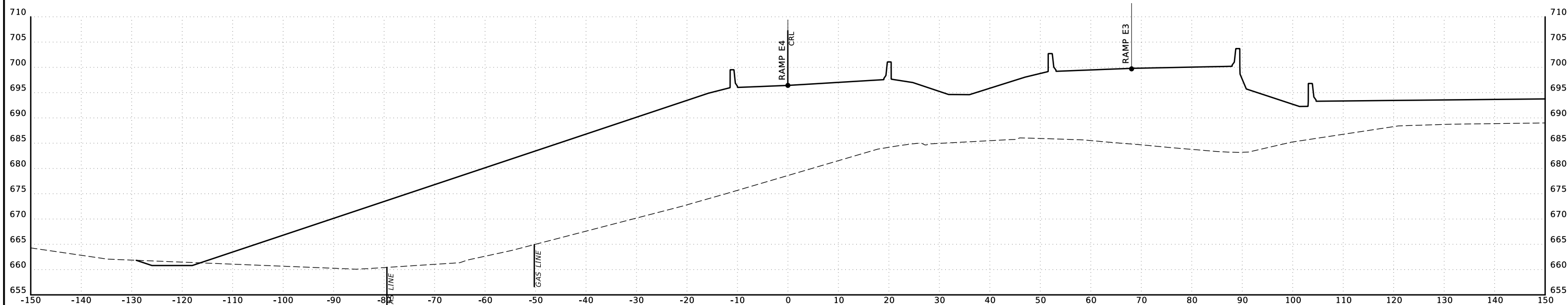

177+50

RAMP E4 STA. 177+50 TO STA. 178+00

P:\FDB\1650-TUL\CIV\400315_000T_EC2123A_US75_Design-Working\CIV\MicroStation\3378811-CrossSections.dgn

SCALE: 1"=10'

R/W UTILITY MEETING

MARCH 2021

3/4/2021

P:\FDB\1650-TUL\CIV\1400315_000T_EC2123A_US75\Design-Working\CIV\MicroStation\3378811-WP5\3378811-CrossSections.dgn

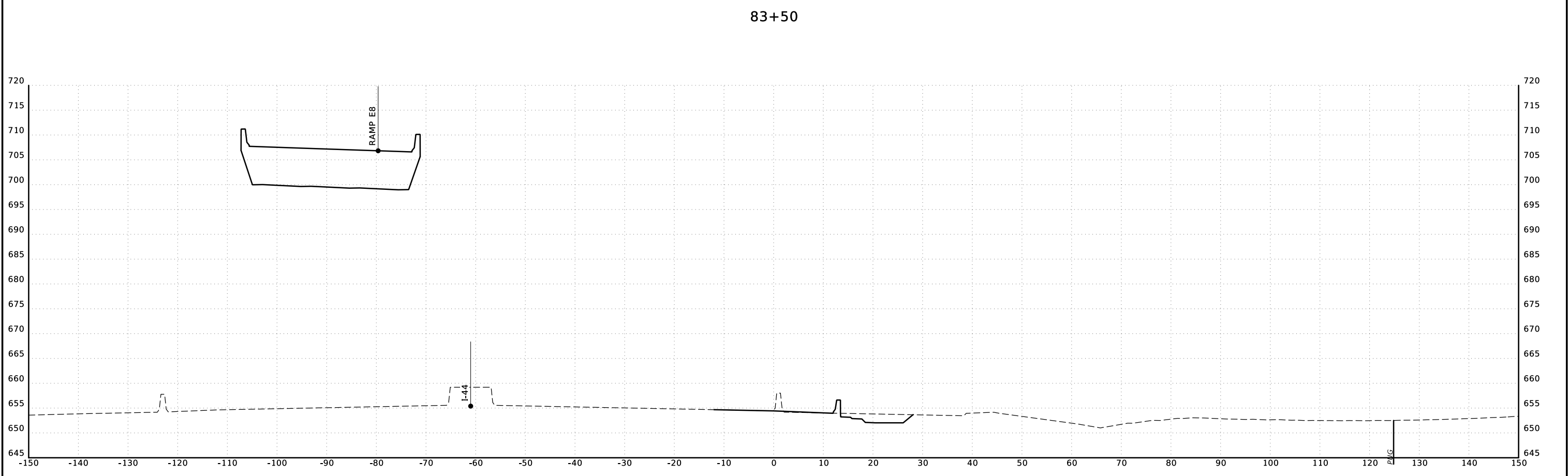
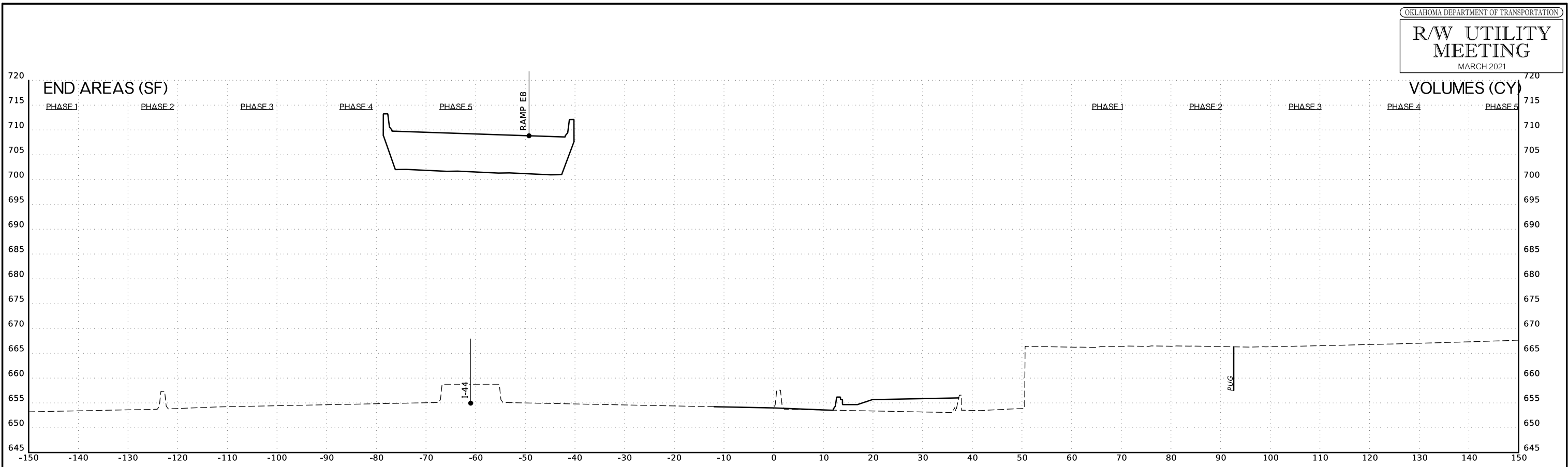

RAMP E5 STA. 83+00 TO STA. 83+50

SCALE: 1"=10'

END AREAS (SF)

PHASE1 PHASE2 PHASE3 PHASE4 PHASE5

VOLUMES (CY)

PHASE1 PHASE2 PHASE3 PHASE4 PHASE5

3/4/2021

P:\FDB\1650-TUL\CIV\1400315-000T_EC2123A_US75_Design-Working\CIV\MicroStation\3378811-WP5\3378811-CrossSections.dgn

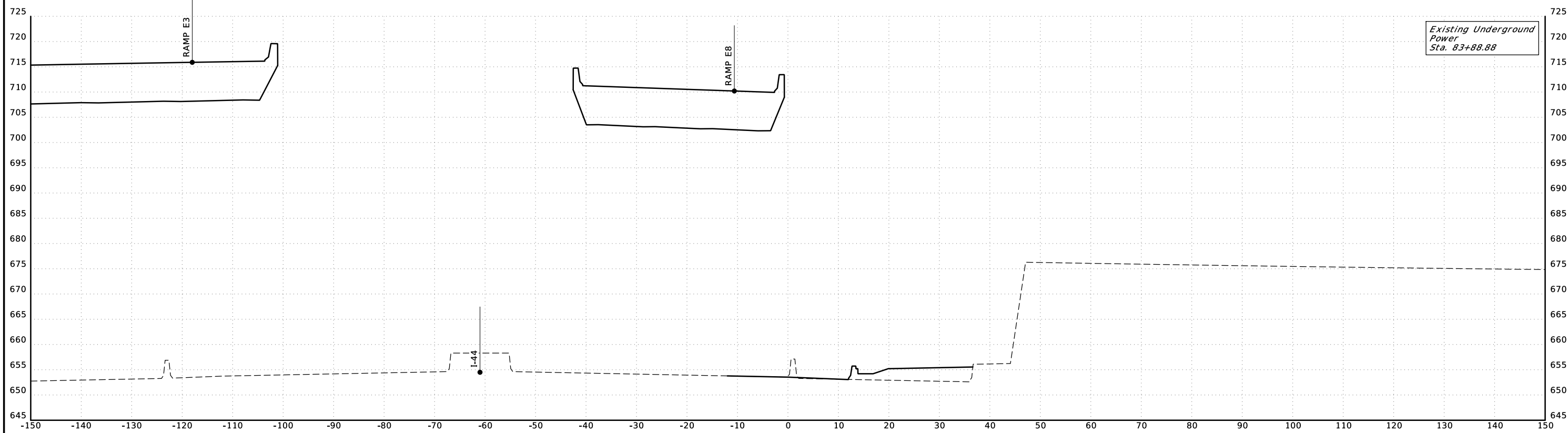

84+00

RAMP E5 STA. 84+00 TO STA. 84+00

SCALE: 1"=10'

END AREAS (SF)

PHASE 1 PHASE 2 PHASE 3 PHASE 4 PHASE 5

VOLUMES (CY)

PHASE 1 PHASE 2 PHASE 3 PHASE 4 PHASE 5

3/4/2021

P:\FDB\1650-TUL\CIV\1400315-000T_EC2123A_US75\Design-Working\CIV\MicroStation\3378811-WP5\3378811-CrossSections.dgn

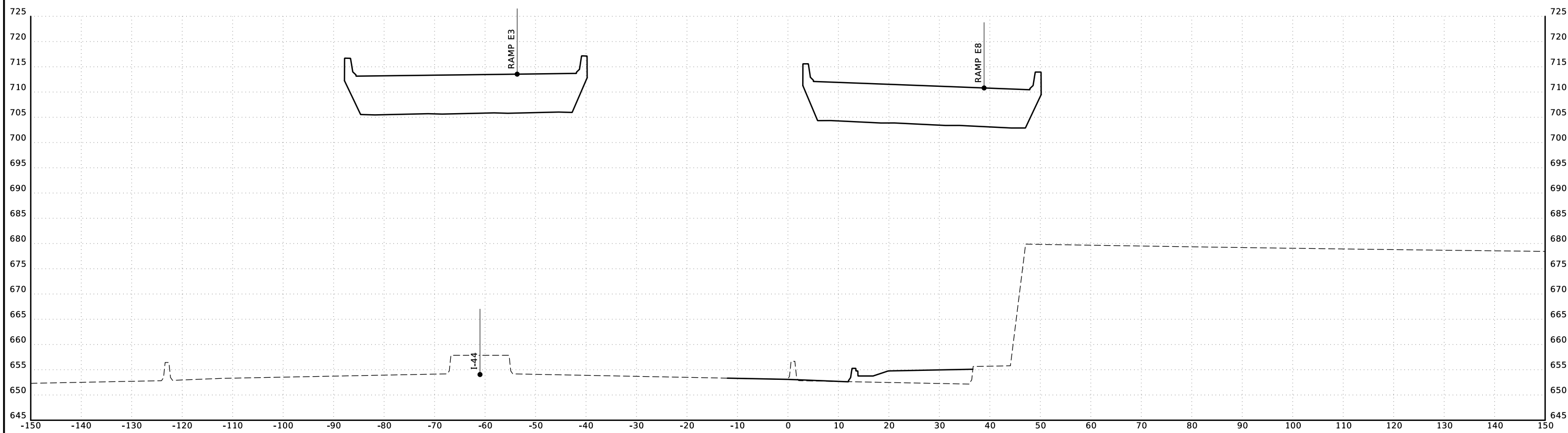

84+50

RAMP E5 STA. 84+50 TO STA. 84+50

SCALE: 1"=10'

3/4/2021

END AREAS (SF)

PHASE 1 PHASE 2 PHASE 3 PHASE 4 PHASE 5

VOLUMES (CY)

PHASE 1 PHASE 2 PHASE 3 PHASE 4 PHASE 5

P:\FDB\1650-TUL\CIV\1400315_000T_EC2123A_US75\Design-Working\CIV\MicroStation\3378811-WP5\3378811-CrossSections.dgn

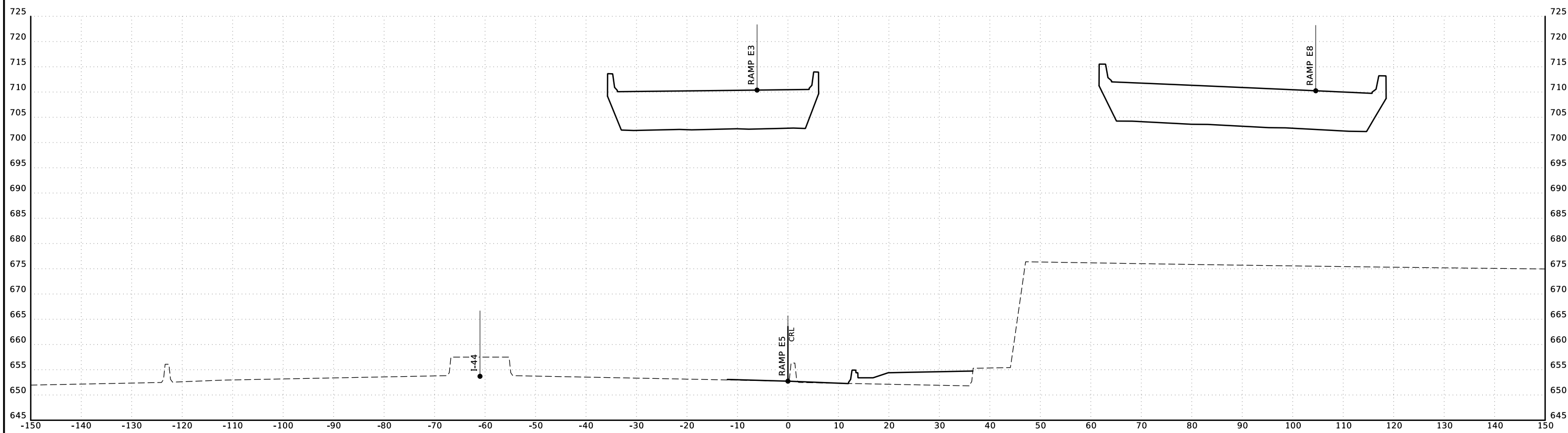

85+00

RAMP E5 STA. 85+00 TO STA. 85+00

SCALE: 1"=10'

3/4/2021

P:\FDB\1650-TUL\CIV\1400315_000T_EC2123A_US75\Design-Working\CIV\MicroStation\3378811-WP5\3378811-CrossSections.dgn

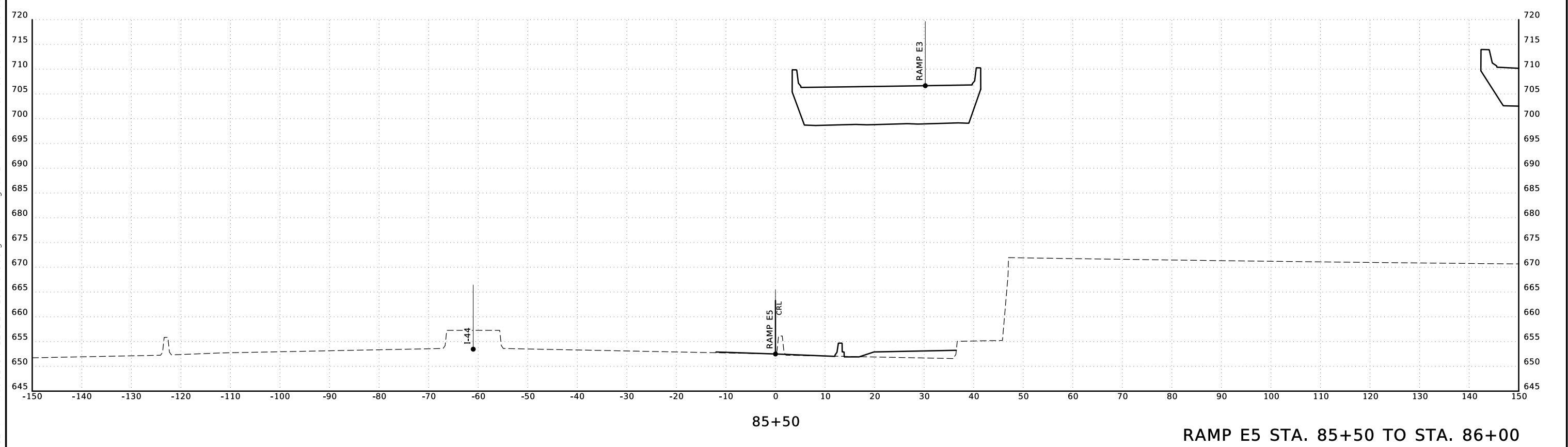
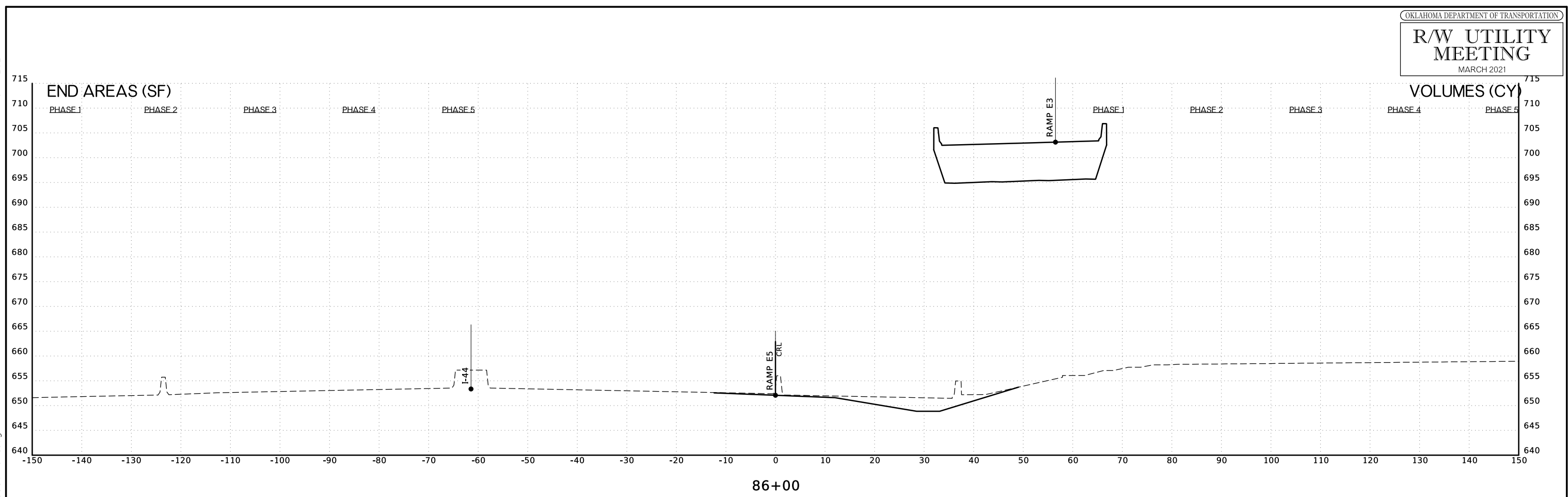

RAMP E5 STA. 85+50 TO STA. 86+00

SCALE: 1"=10'

3/4/2021

P:\FDB\1650-TUL\CIV\1400315_000T_EC2123A_US75_Design-Working\CIV\MicroStation\3378811-WP5\3378811-CrossSections.dgn

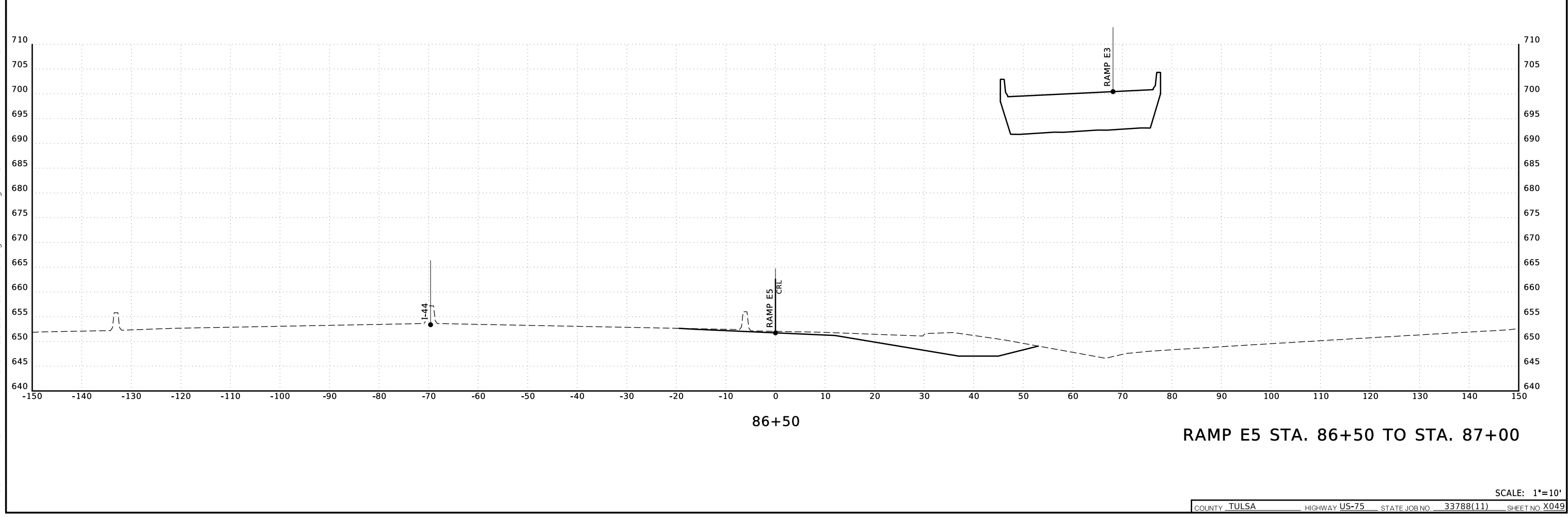
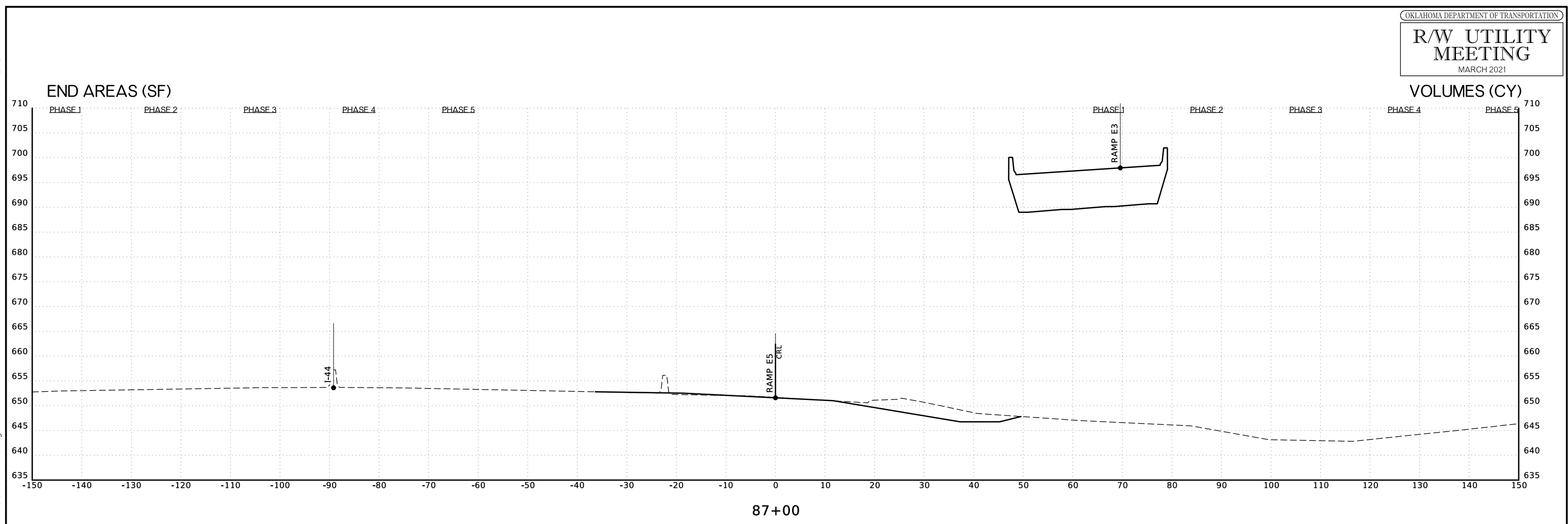

RAMP E5 STA. 86+50 TO STA. 87+00

SCALE: 1"=10'

3/4/2021

END AREAS (SF)

VOLUMES (CY)

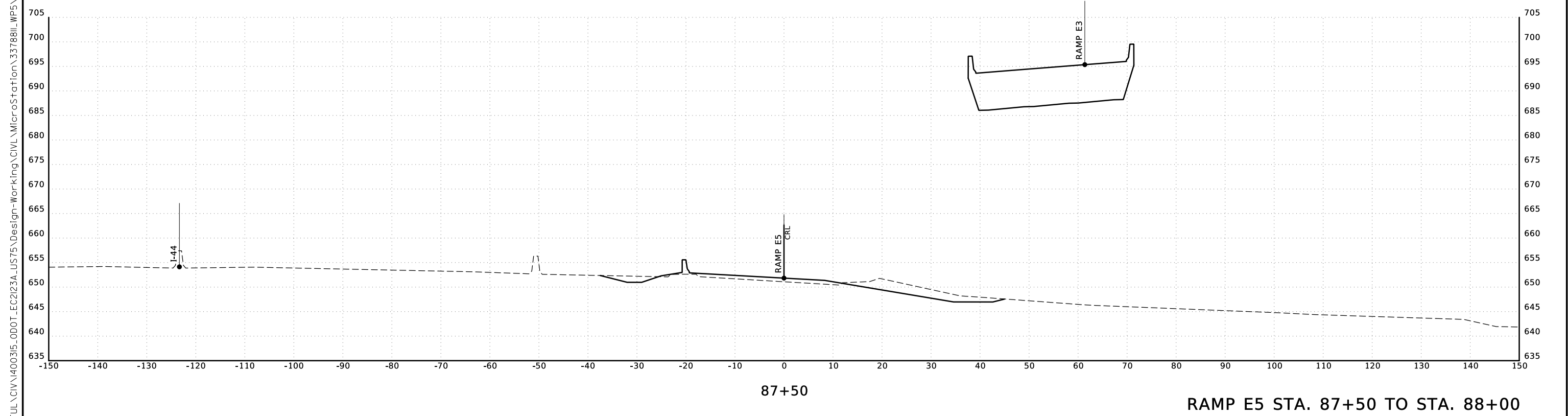
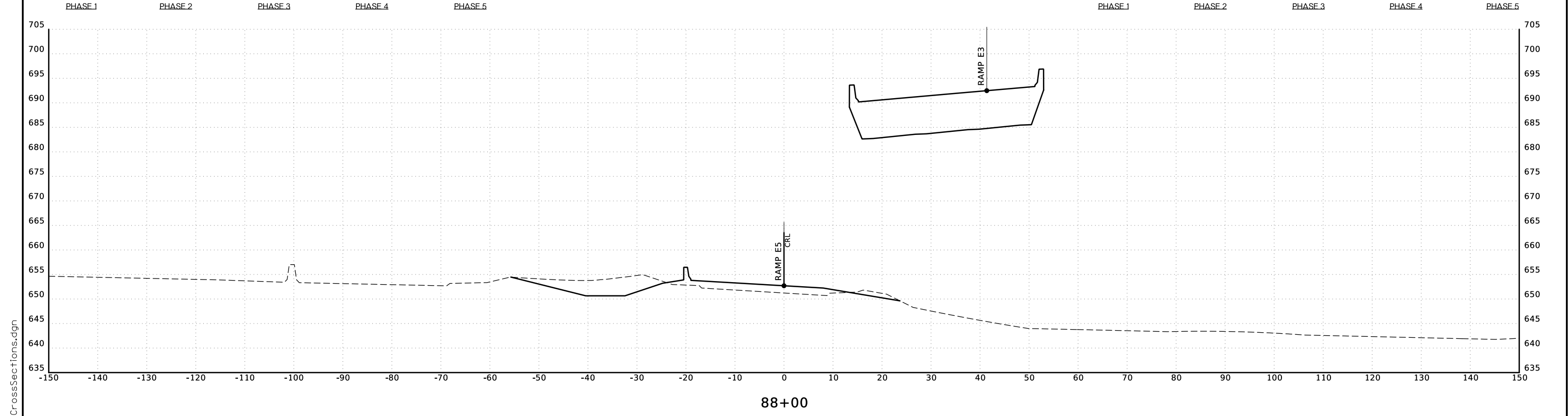

RAMP E5 STA. 87+50 TO STA. 88+00

P:\FDB\1650-TUL\CIV\1400315_000T_EC2123A_US75_Design-Working\CIV\MicroStation\3378811-WP5\3378811-CrossSections.dgn

SCALE: 1"=10'

3/4/2021

END AREAS (SF)

VOLUMES (CY)

PHASE 1 PHASE 2 PHASE 3 PHASE 4 PHASE 5

PHASE 1 PHASE 2 PHASE 3 PHASE 4 PHASE 5

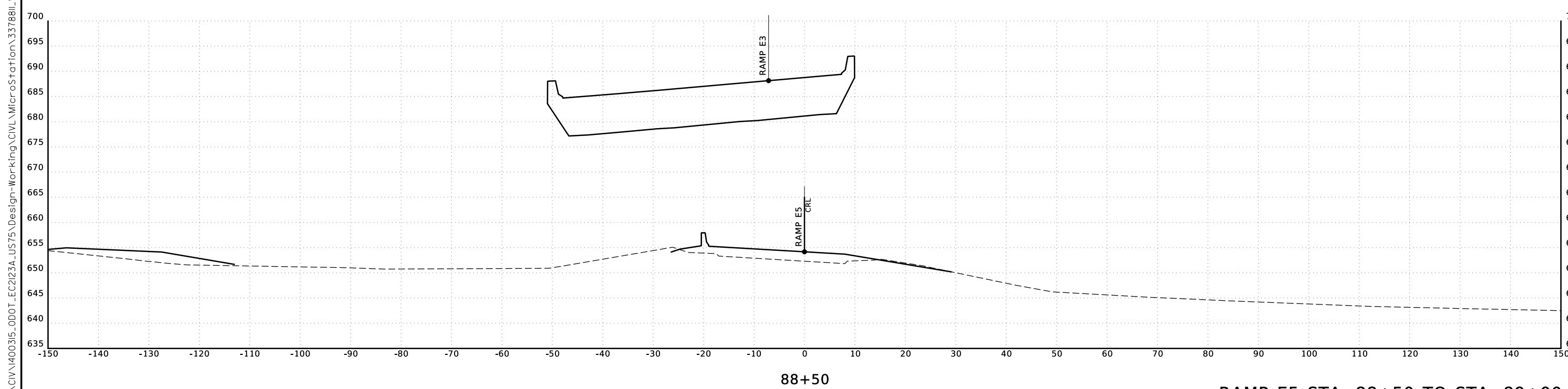
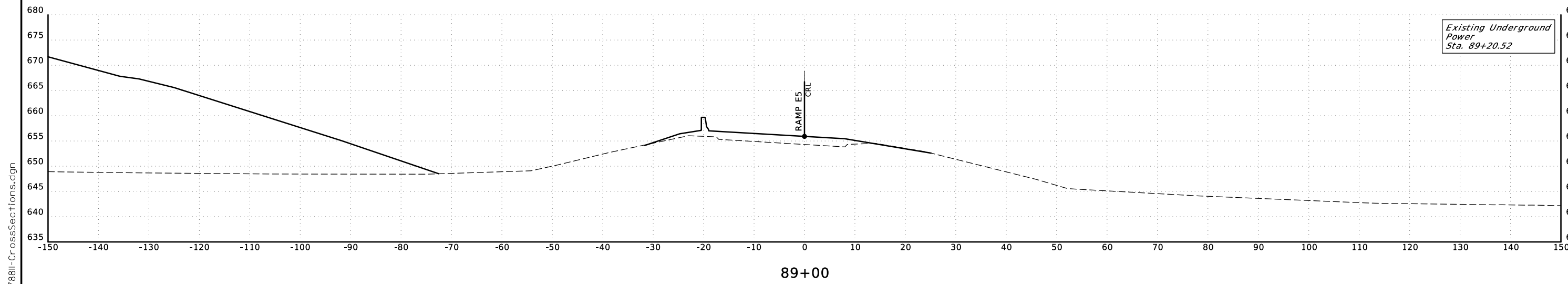

RAMP E5 STA. 88+50 TO STA. 89+00

P:\FDB\1650-TUL\CIV\1400315_000T_EC2123A_US75_Design-Working\CIV\MicroStation\3378811-WP5\3378811-CrossSections.dgn

SCALE: 1"=10'

END AREAS (SF)

VOLUMES (CY)

PHASE 1 PHASE 2 PHASE 3 PHASE 4 PHASE 5 PHASE 1 PHASE 2 PHASE 3 PHASE 4 PHASE 5

STA. 90+59.79 - END RAMP E5

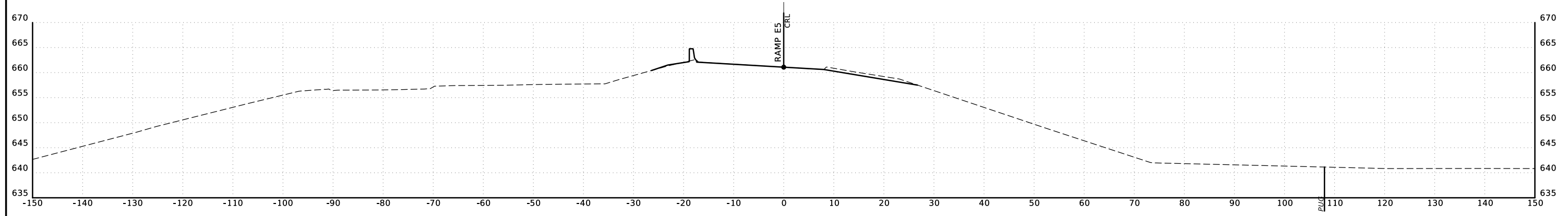

90+50

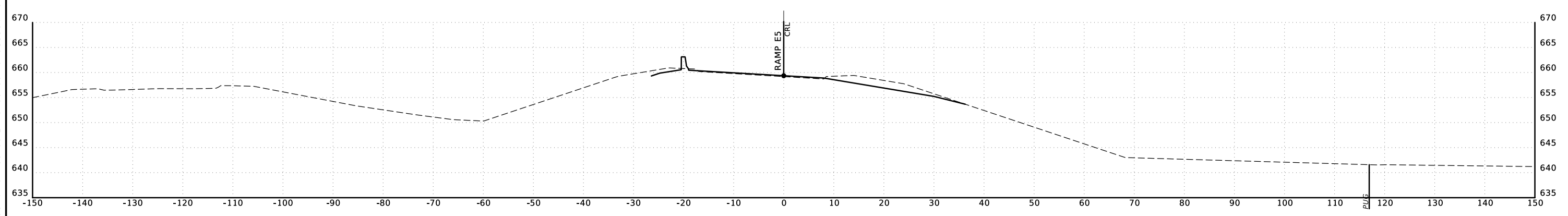

90+00

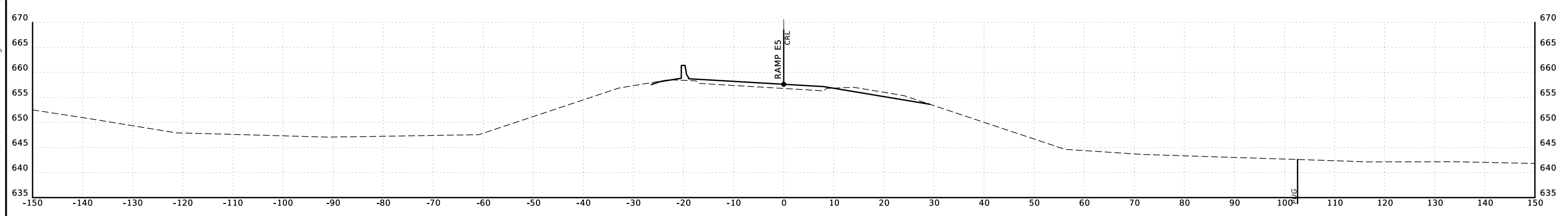

89+50

RAMP E5 STA. 89+50 TO STA. 90+50

3/4/2021

P:\FDB\1650-TUL\CIV\1400315_000T_EC2123A_US75_Design-Working\CIV\MicroStation\3378811-WP5\3378811-CrossSections.dgn

SCALE: 1"=10'

3/4/2021

END AREAS (SF)

PHASE 1

PHASE 2

PHASE 3

PHASE 4

PHASE 5

VOLUMES (CY)

PHASE 1

PHASE 2

PHASE 3

PHASE 4

PHASE 5

P:\FDB\1650-TUL\CIV\1400315-000T_EC2123A_US75_Design-Working\CIV\MicroStation\3378811-WP5\3378811-CrossSections.dgn

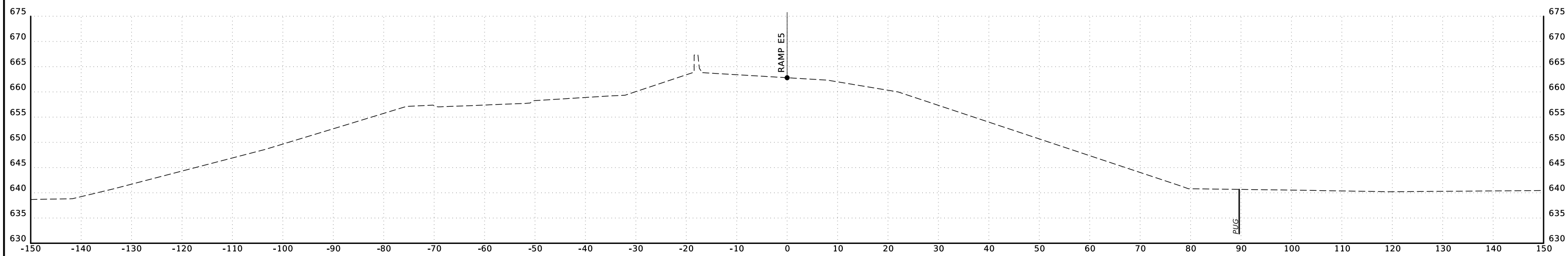

91+00

RAMP E5 STA. 91+00 TO STA. 91+00

SCALE: 1"=10'

END AREAS (SF)

VOLUMES (CY)

PHASE 1

PHASE 2

PHASE 3

PHASE 4

PHASE 5

PHASE 1

PHASE 2

PHASE 3

PHASE 4

PHASE 5

STA. 61+73.53 - BEGIN BRIDGE 'P'

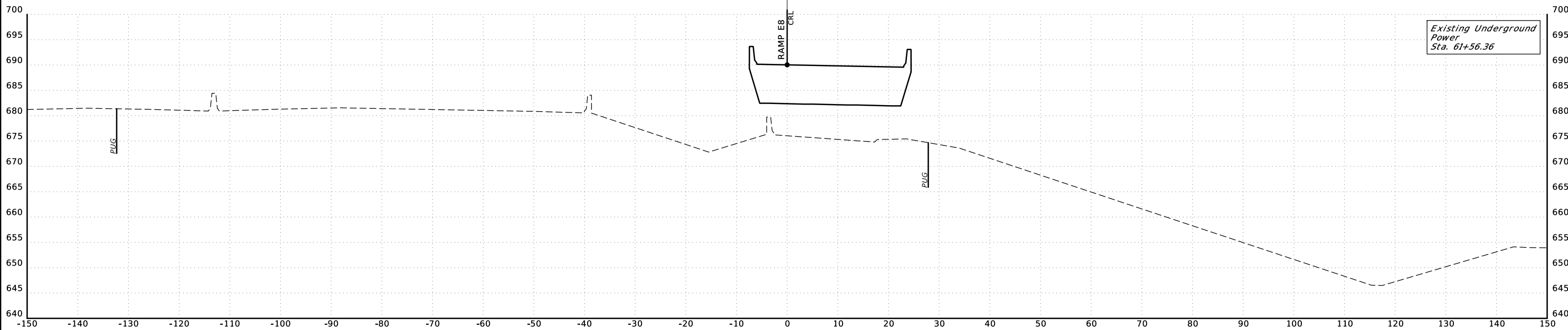

61+50

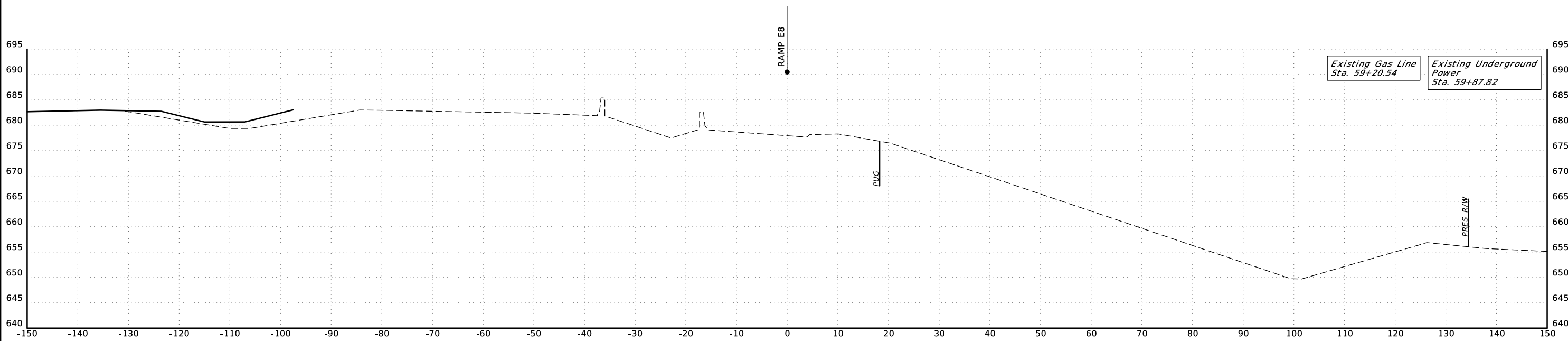

61+00

RAMP E8 STA. 61+00 TO STA. 61+50

3/4/2021

P:\FDB\1650-TUL\CIV\1400315_000T_EC2123A_US75_Design-Working\CIV\MicroStation\3378811-CrossSections.dgn

SCALE: 1"=10'

R/W UTILITY MEETING

MARCH 2021

3/4/2021

END AREAS (SF)

PHASE 1 PHASE 2 PHASE 3 PHASE 4 PHASE 5

VOLUMES (CY)

PHASE 1 PHASE 2 PHASE 3 PHASE 4 PHASE 5

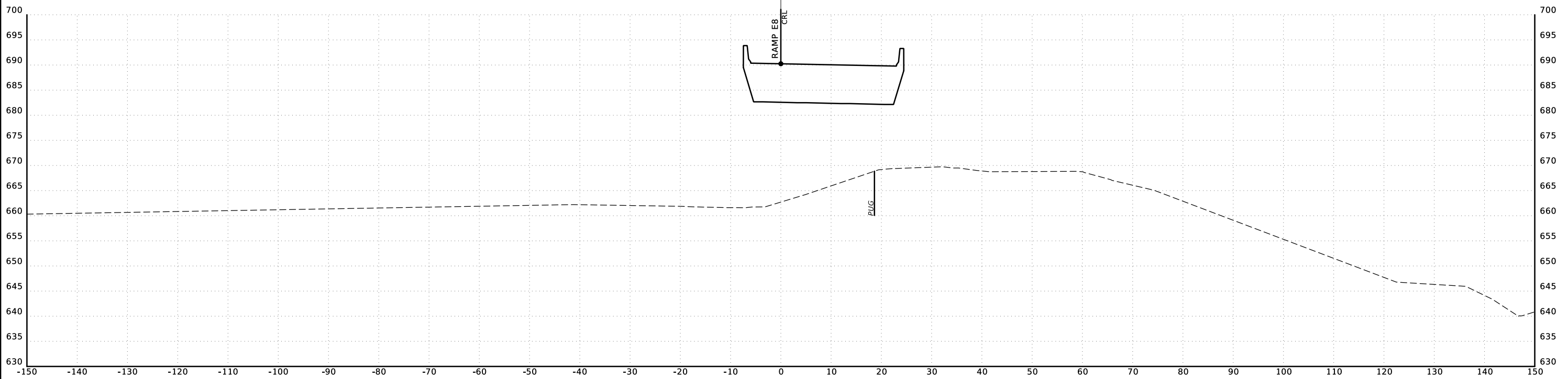

62+50

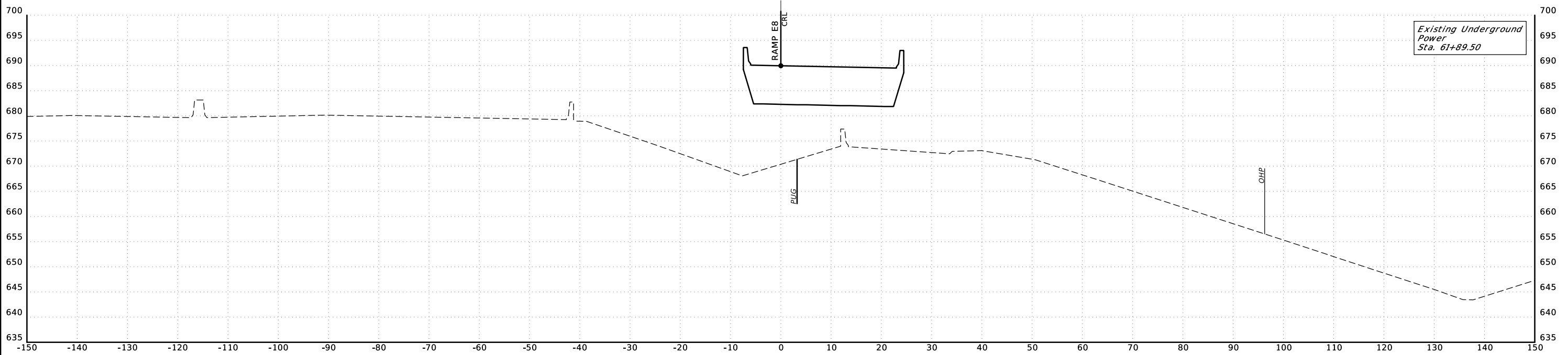

62+00

RAMP E8 STA. 62+00 TO STA. 62+50

P:\FDB\1650-TUL\CIV\1400315_000T_EC2123A_US75\Design-Working\CIV\MicroStation\3378811_WP5\3378811-CrossSections.dgn

SCALE: 1"=10'

R/W UTILITY MEETING

MARCH 2021

END AREAS (SF)

PHASE 1

PHASE 2

PHASE 3

PHASE 4

PHASE 5

VOLUMES (CY)

PHASE 1

PHASE 2

PHASE 3

PHASE 4

PHASE 5

3/4/2021

P:\FDB\1650-TUL\CIV\1400315_000T_EC2123A_US75_Design-Working\CIV\MicroStation\3378811-WP5\3378811-CrossSections.dgn

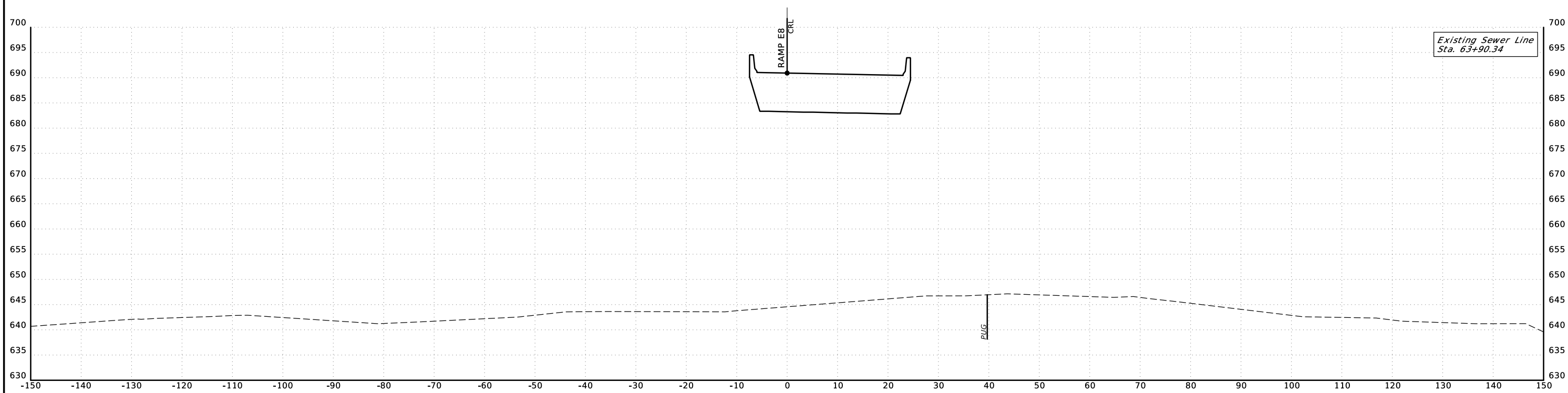

63+00

RAMP E8 STA. 63+00 TO STA. 63+00

SCALE: 1"=10'

END AREAS (SF)

PHASE 1 PHASE 2 PHASE 3 PHASE 4 PHASE 5

VOLUMES (CY)

PHASE 1 PHASE 2 PHASE 3 PHASE 4 PHASE 5

3/4/2021

P:\FDB\1650-TUL\CIV\1400315_000T_EC2123A_US75\Design-Working\CIV\MicroStation\3378811-WP5\3378811-CrossSections.dgn

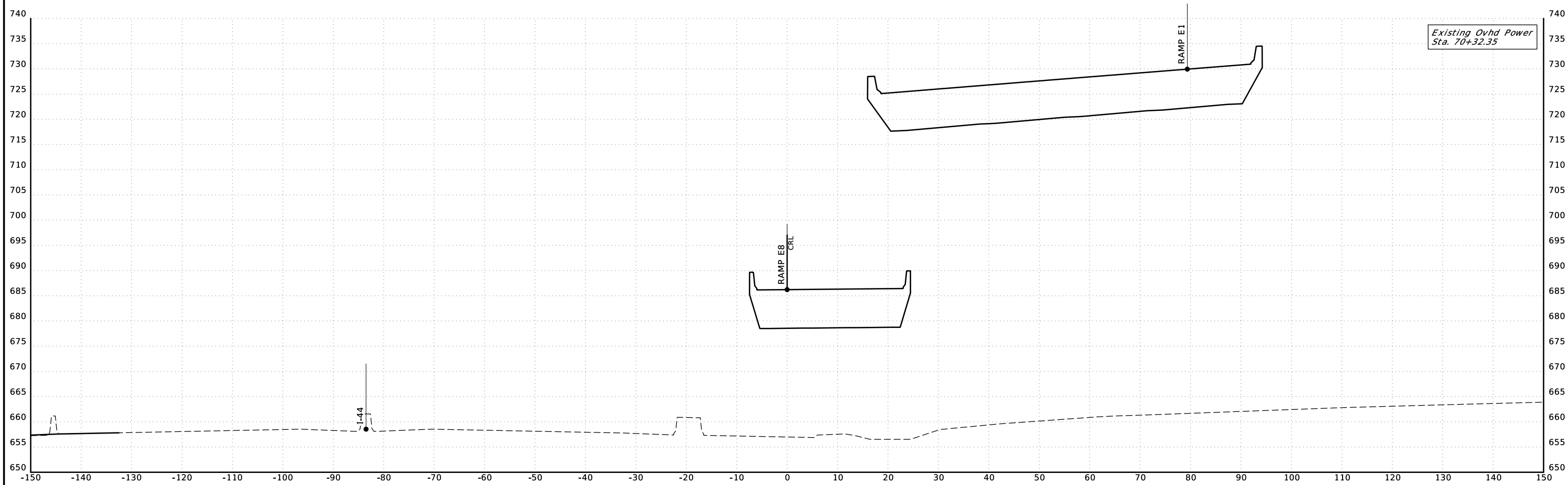

RAMP E8 STA. 75+00 TO STA. 75+00

SCALE: 1"=10'

END AREAS (SF)

PHASE 1 PHASE 2 PHASE 3 PHASE 4 PHASE 5

VOLUMES (CY)

PHASE 1 PHASE 2 PHASE 3 PHASE 4 PHASE 5

3/4/2021

P:\FDB\1650-TUL\CIV\1400315_000T_EC2123A_US75_Design-Working\CIV\MicroStation\3378811-WP5\3378811-CrossSections.dgn

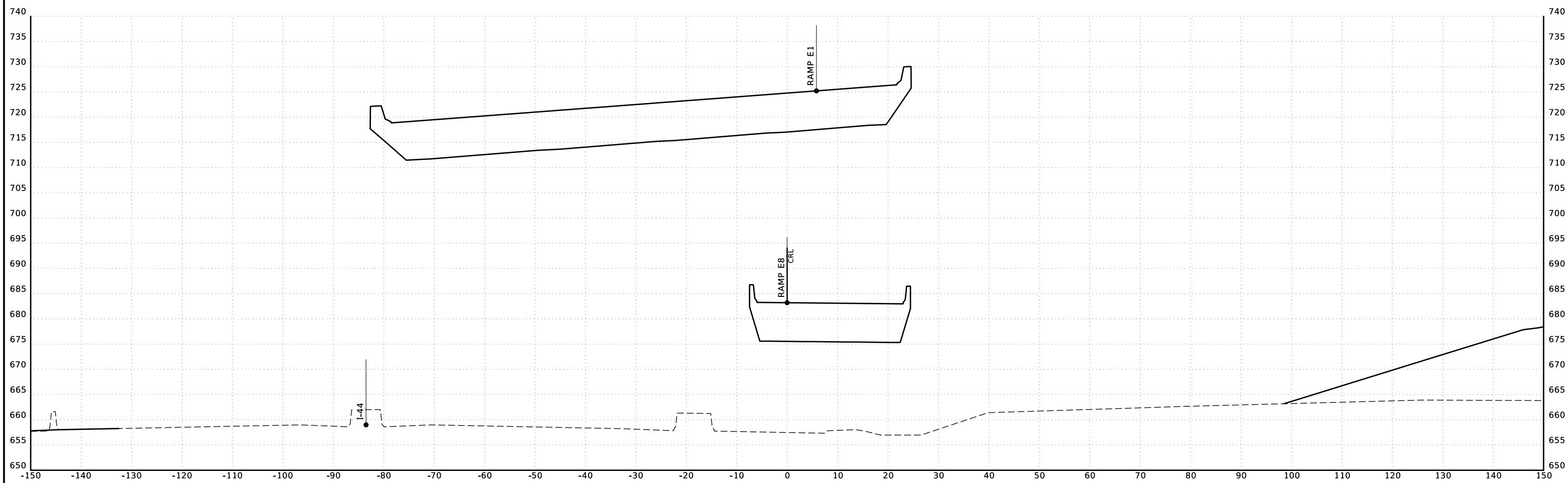

75+50

RAMP E8 STA. 75+50 TO STA. 75+50

SCALE: 1"=10'

3/4/2021

END AREAS (SF)

PHASE 1 PHASE 2 PHASE 3 PHASE 4 PHASE 5

VOLUMES (CY)

PHASE 1 PHASE 2 PHASE 3 PHASE 4 PHASE 5

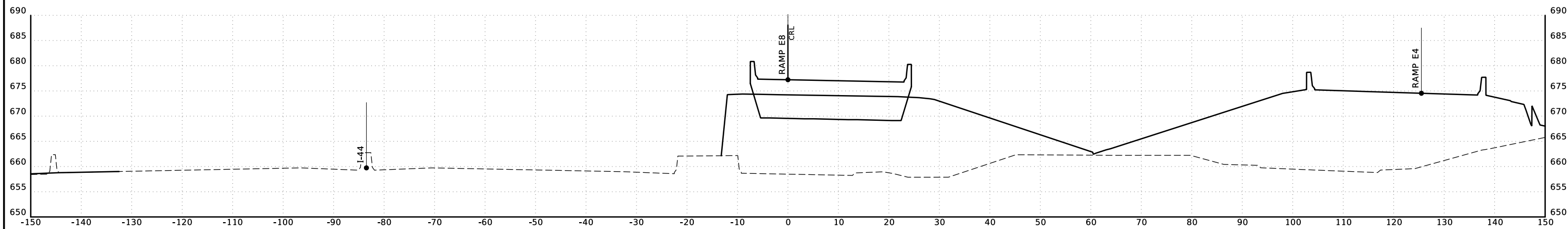

76+50
STA. 76+25.31 - END BRIDGE 'P'

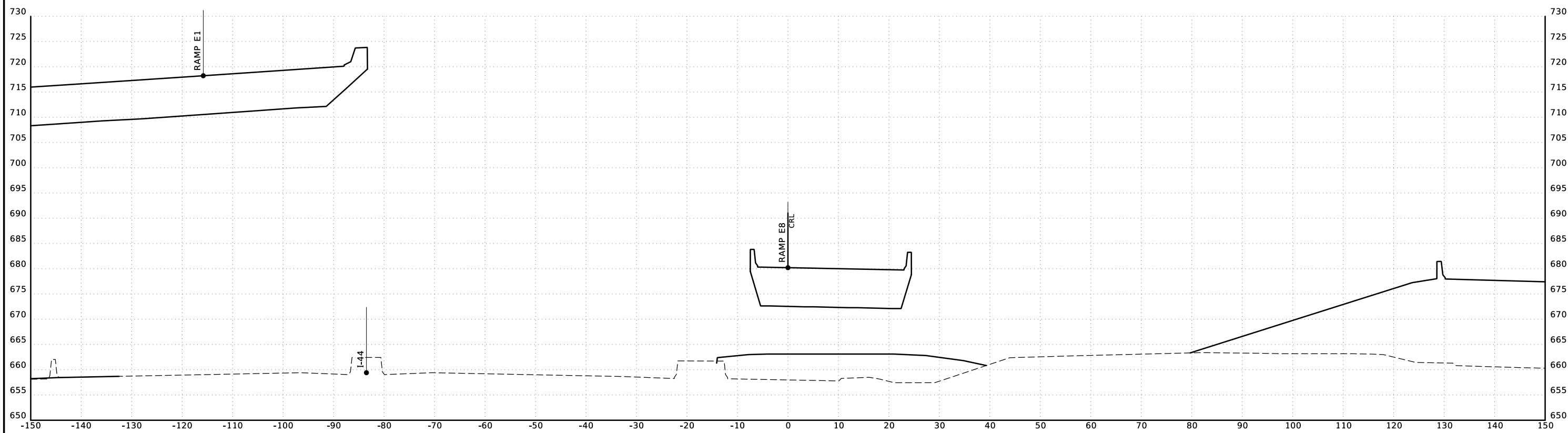

76+00

RAMP E8 STA. 76+00 TO STA. 76+50

P:\FDB\1650-TUL\CIV\1400315_000T_EC2123A_US75\Design-Working\CIV\MicroStation\3378811-WP5\3378811-CrossSections.dgn

END AREAS (SF)

VOLUMES (CY)

PHASE 1 PHASE 2 PHASE 3 PHASE 4 PHASE 5 PHASE 1 PHASE 2 PHASE 3 PHASE 4 PHASE 5

3/4/2021

P:\FDB\1650-TUL\CIV\400315_000T_EC2123A_US75_Design-Working\CIV\MicroStation\3378811-WP5\3378811-CrossSections.dgn

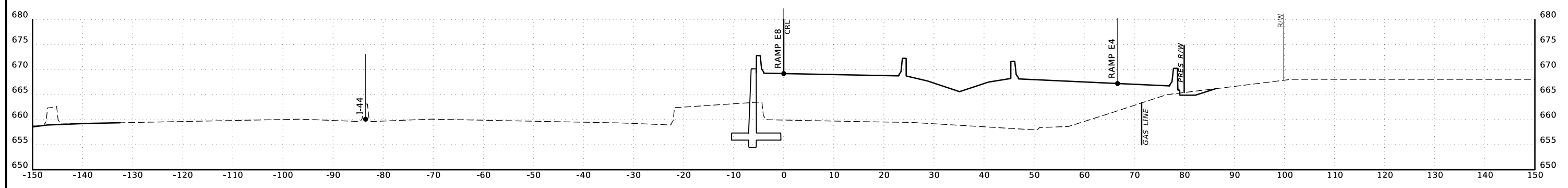

78+00

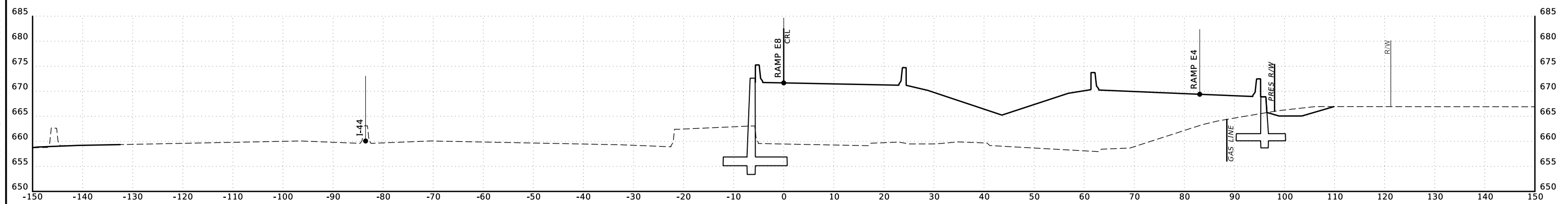

77+50

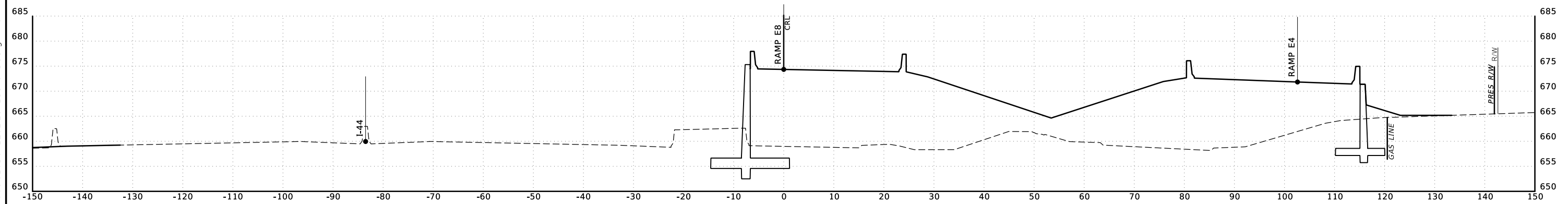

77+00

RAMP E8 STA. 77+00 TO STA. 78+00

SCALE: 1"=10'

3/4/2021
 P:\FDB\1650-TUL\CIV\400315_000T_EC2123A_US75\Design-Working\CIV\MicroStation\3378811-WP5\3378811-CrossSections.dgn

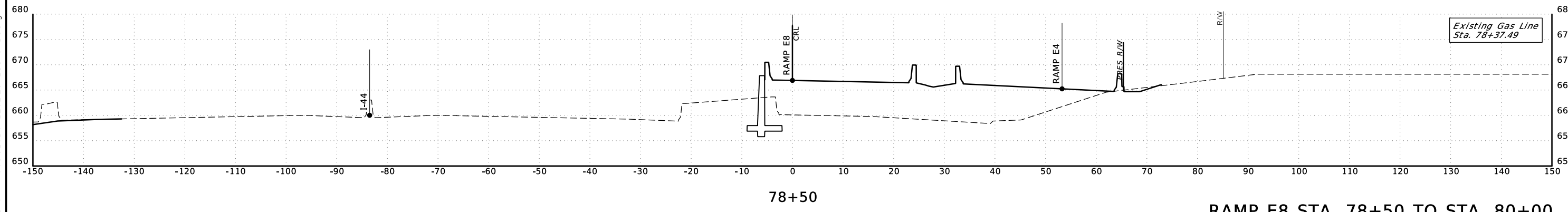
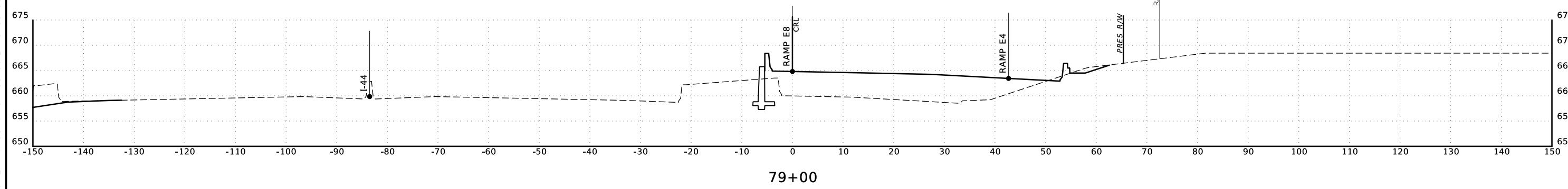
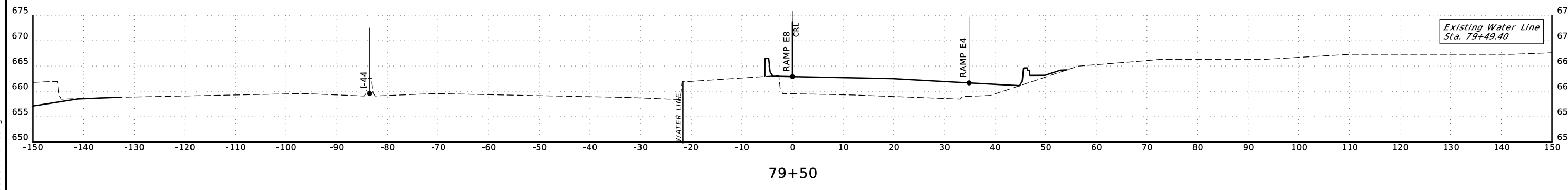
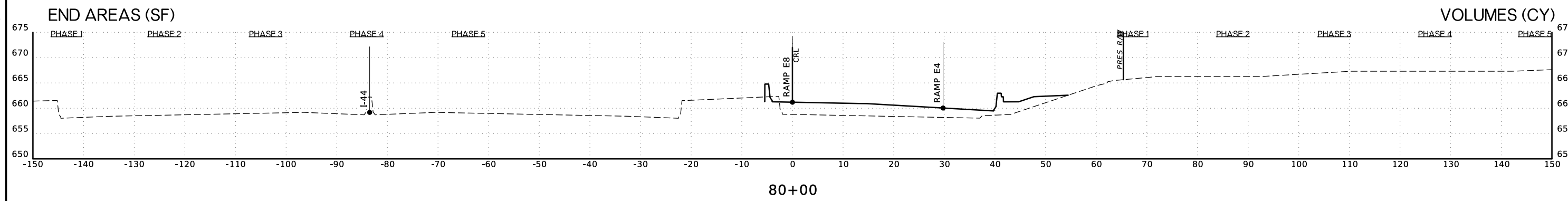

RAMP E8 STA. 78+50 TO STA. 80+00

END AREAS (SF)

PHASE 1 PHASE 2 PHASE 3 PHASE 4 PHASE 5

VOLUMES (CY)

PHASE 1 PHASE 2 PHASE 3 PHASE 4 PHASE 5

P:\FDB\1650-TUL\CIV\1400315_000T_EC2123A_US75\Design-Working\CIV\MicroStation\3378811-WP5\3378811-CrossSections.dgn

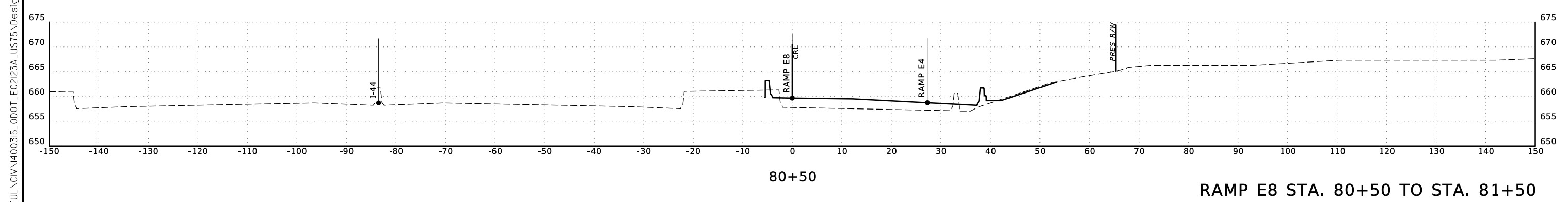
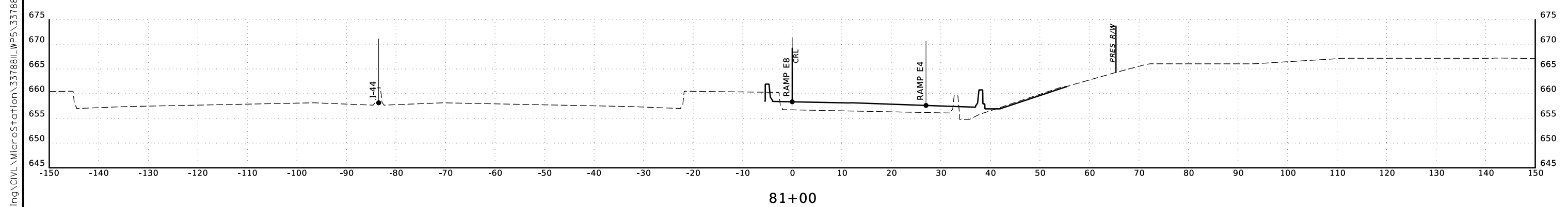
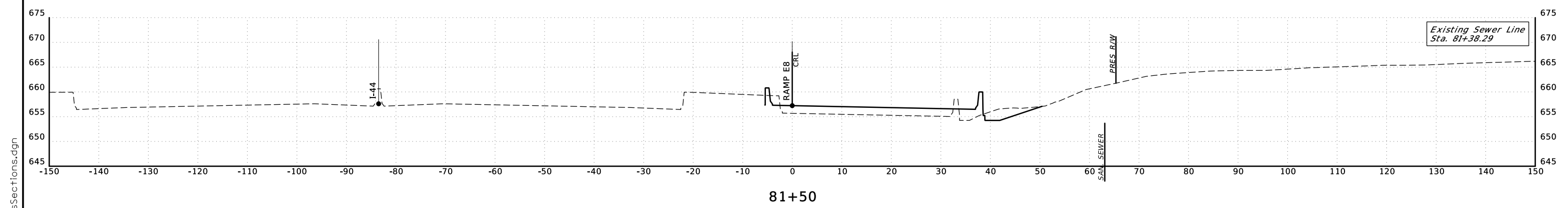

RAMP E8 STA. 80+50 TO STA. 81+50

SCALE: 1"=10'

P:\FDB\1650-TUL\CIV\400315_000T_EC2123A_US75_Design-Working\CIV\MicroStation\3378811-WP5\3378811-CrossSections.dgn

END AREAS (SF)

PHASE 1 PHASE 2 PHASE 3 PHASE 4 PHASE 5

VOLUMES (CY)

PHASE 1 PHASE 2 PHASE 3 PHASE 4 PHASE 5

STA. 83+00.00 - END RAMP E8

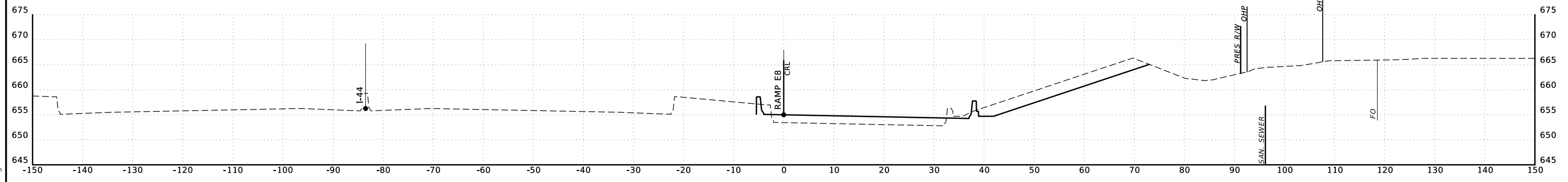

83+00

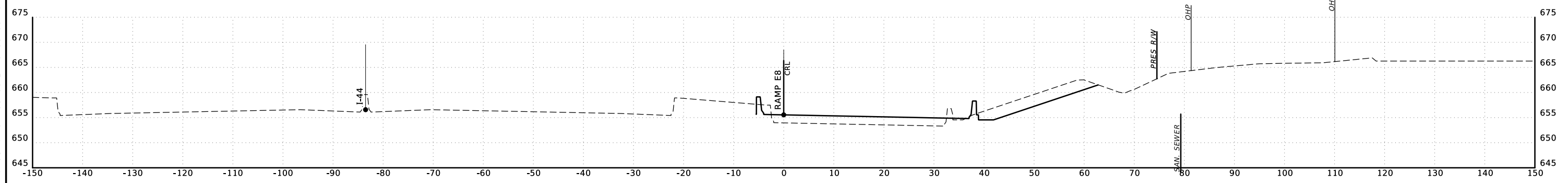

82+50

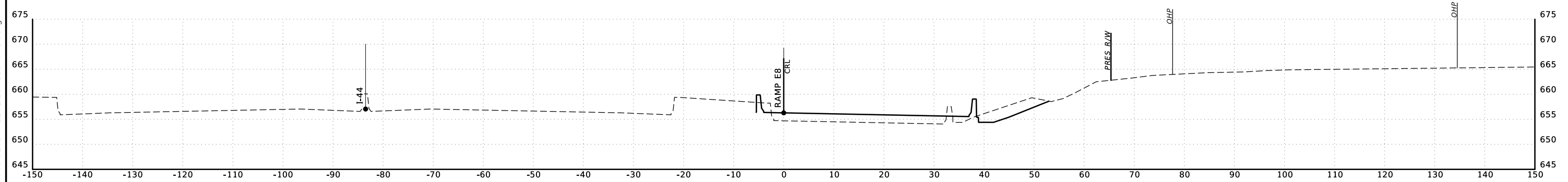

82+00

RAMP E8 STA. 82+00 TO STA. 83+00

SCALE: 1"=10'

END AREAS (SF)

PHASE 1 PHASE 2 PHASE 3 PHASE 4 PHASE 5

VOLUMES (CY)

PHASE 1 PHASE 2 PHASE 3 PHASE 4 PHASE 5

3/4/2021

P:\FDB\1650-TUL\CIV\400315_000T_EC2123A_US75_Design-Working\CIV\MicroStation\3378811-WP5\3378811-CrossSections.dgn

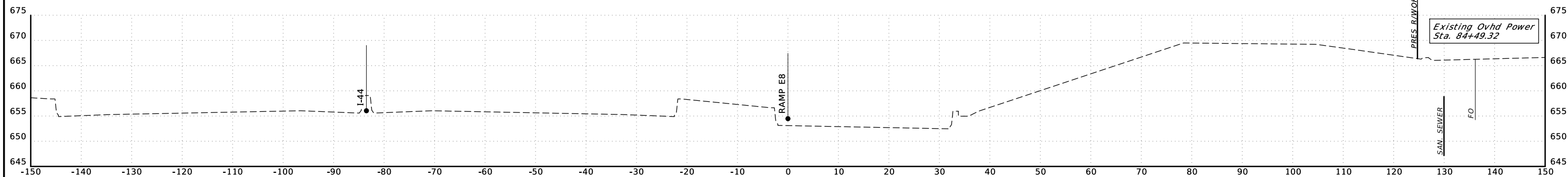

84+00

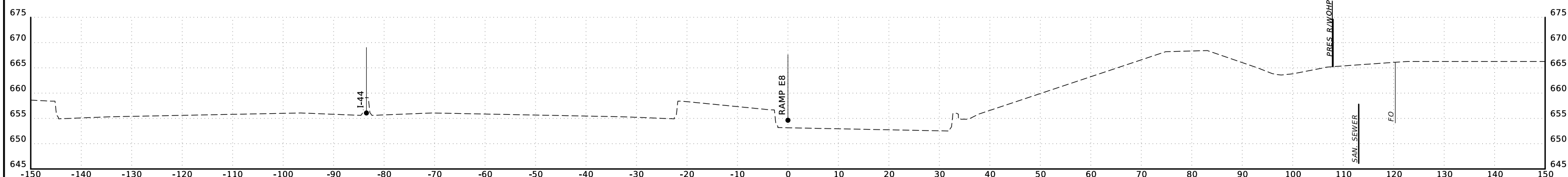

83+50

RAMP E8 STA. 83+50 TO STA. 84+00

SCALE: 1"=10'

3/4/2021

END AREAS (SF)

VOLUMES (CY)

PHASE 1 PHASE 2 PHASE 3 PHASE 4 PHASE 5 PHASE 1 PHASE 2 PHASE 3 PHASE 4 PHASE 5

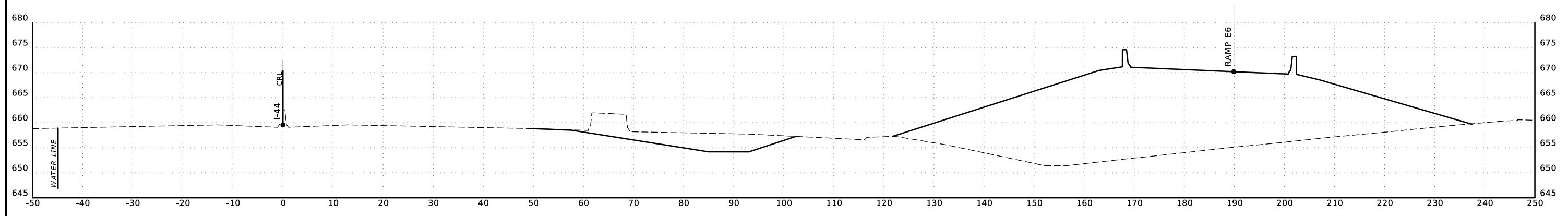

275+00

STA. 274+84.88 - BEGIN I-44 EB WIDENING

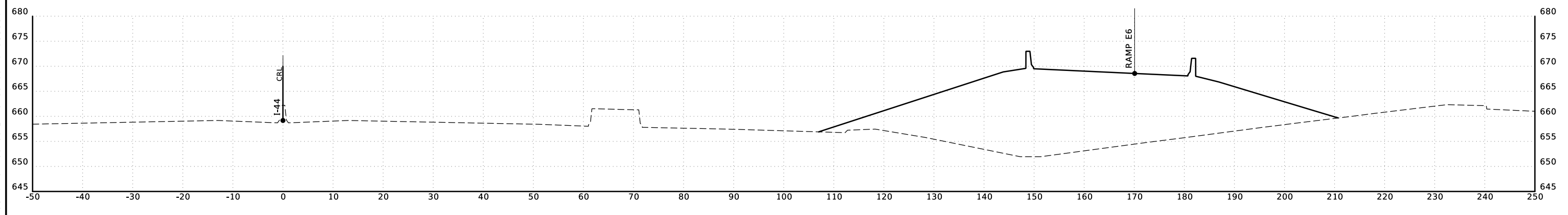

274+50

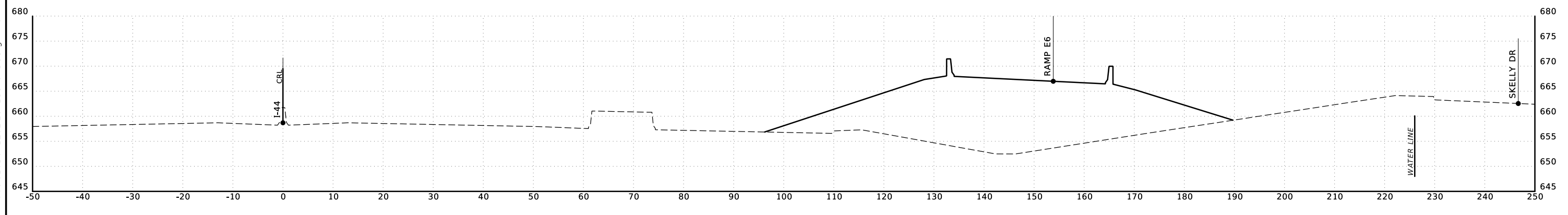

274+00

I-44 STA. 274+00 TO STA. 275+00

P:\FDB\1650-TUL\CIV\400315_000T_EC2123A_US75_Design-Working\CIV\MicroStation\3378811-WP5\3378811-CrossSections.dgn

SCALE: 1"=10'

3/4/2021

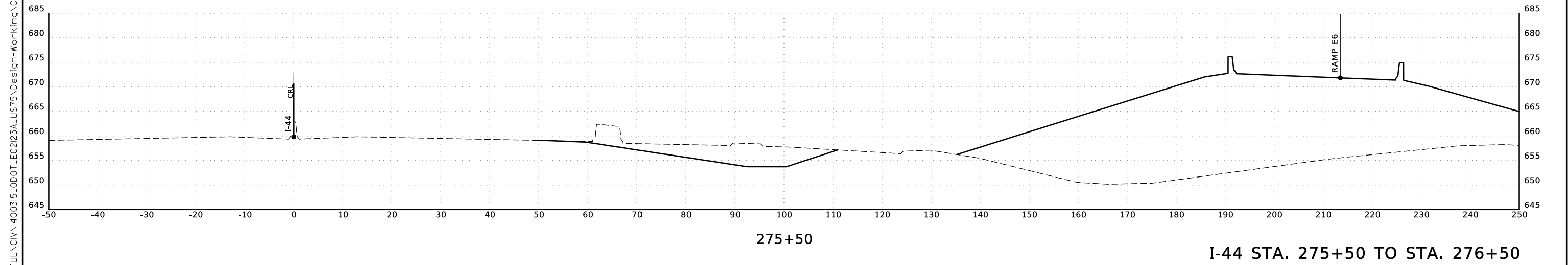
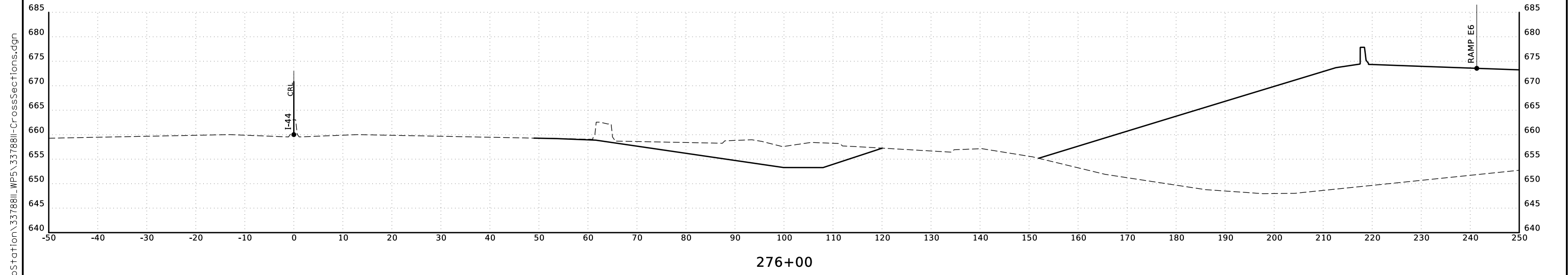
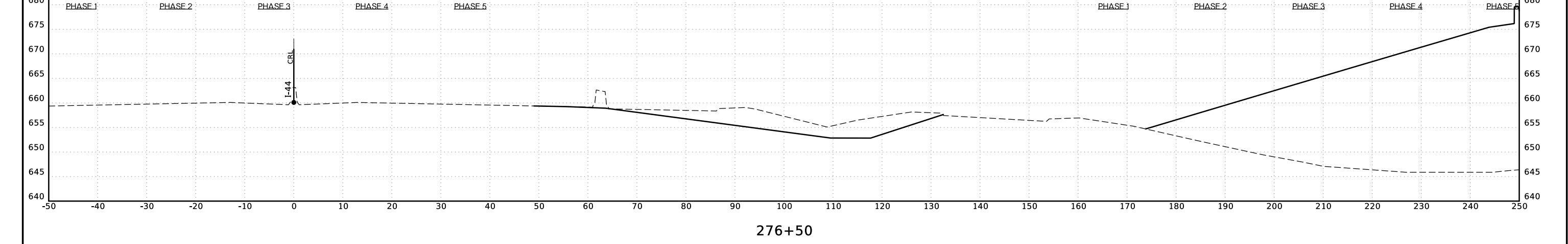

I-44 STA. 275+50 TO STA. 276+50

P:\FDB\1650-TUL\CIV\1400315_000T_EC2123A_US75_Design-Working\CIV\MicroStation\3378811-WP5\3378811-CrossSections.dgn

SCALE: 1"=10'

3/4/2021

END AREAS (SF)

VOLUMES (CY)

PHASE 1

PHASE 2

PHASE 3

PHASE 4

PHASE 5

PHASE 1

PHASE 2

PHASE 3

PHASE 4

PHASE 5

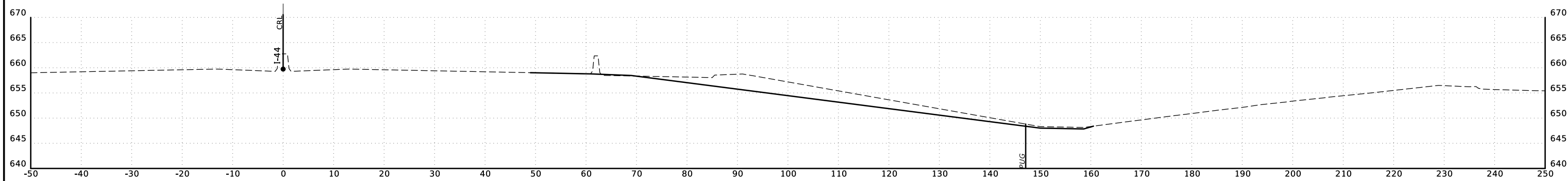

278+00

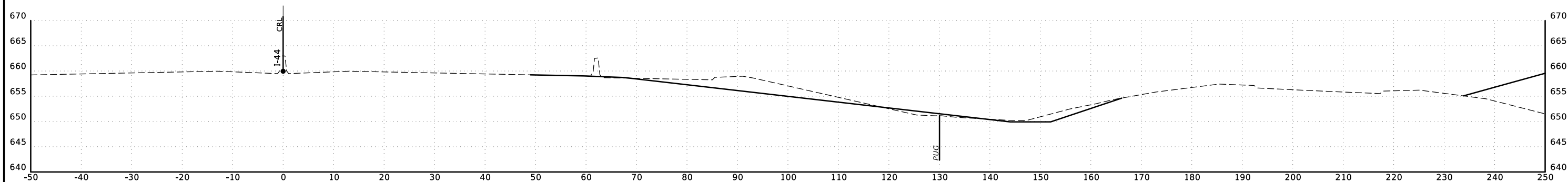

277+50

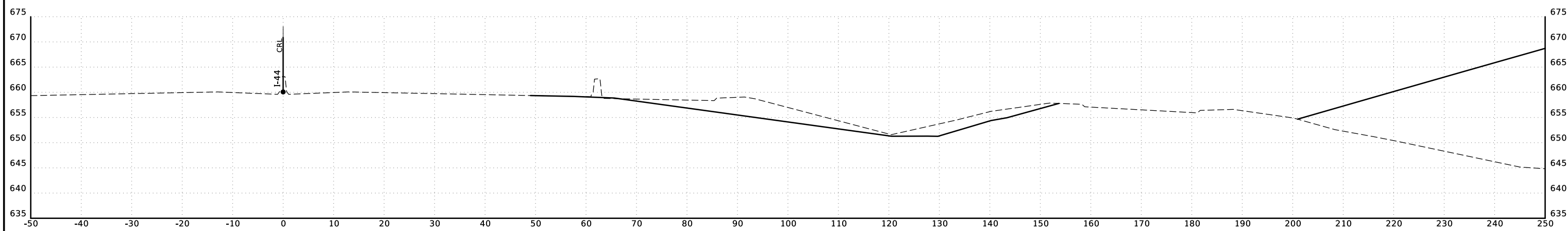

277+00

I-44 STA. 277+00 TO STA. 278+00

P:\FDB\1650-TUL\CIV\400315_000T_EC2123A_US75_Design-Working\CIV\MicroStation\3378811-WP5\3378811-CrossSections.dgn

SCALE: 1"=10'

END AREAS (SF)

PHASE 1 PHASE 2 PHASE 3 PHASE 4 PHASE 5

VOLUMES (CY)

PHASE 1 PHASE 2 PHASE 3 PHASE 4 PHASE 5

3/4/2021

P:\FDB\1650-TUL\CIV\1400315_000T_EC2123A_US75_Design-Working\CIV\MicroStation\3378811-WP5\3378811-CrossSections.dgn

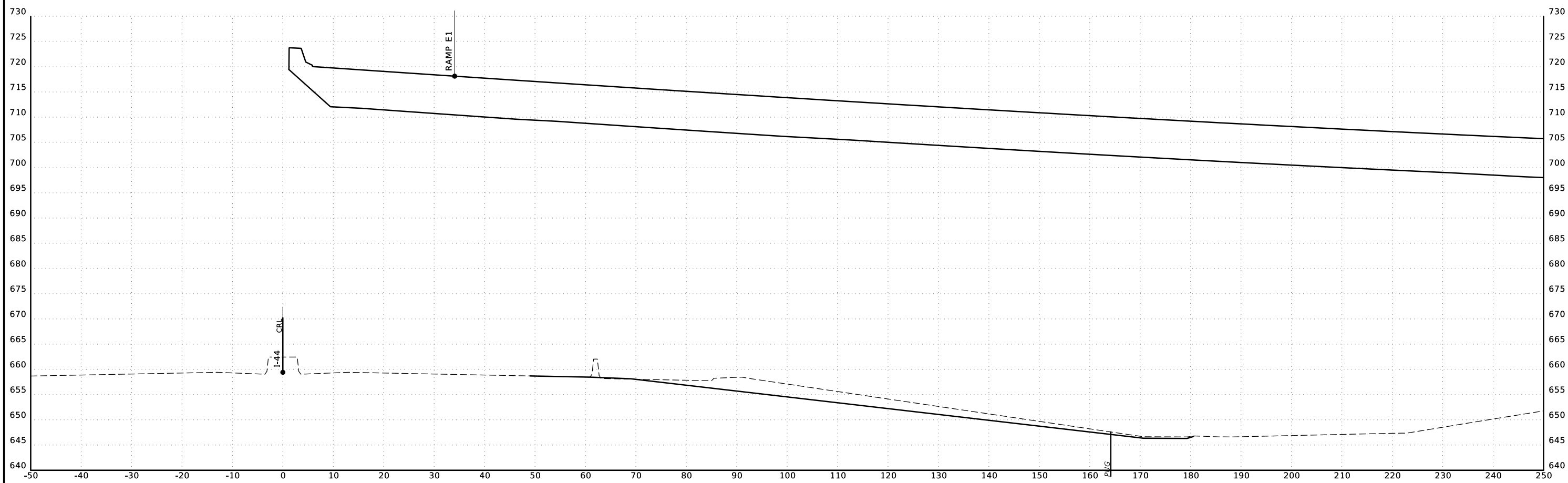

278+50

I-44 STA. 278+50 TO STA. 278+50

SCALE: 1"=10'

R/W UTILITY MEETING

MARCH 2021

3/4/2021

END AREAS (SF)

VOLUMES (CY)

PHASE 1

PHASE 2

PHASE 3

PHASE 4

PHASE 5

PHASE 1

PHASE 2

PHASE 3

PHASE 4

PHASE 5

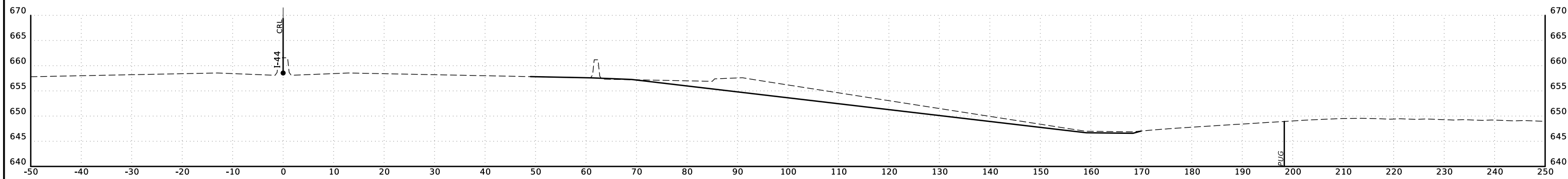

279+50

P:\FDB\1650-TUL\CIV\400315_000T_EC2123A_US75_Design-Working\CIV\MicroStation\3378811-WP5\3378811-CrossSections.dgn

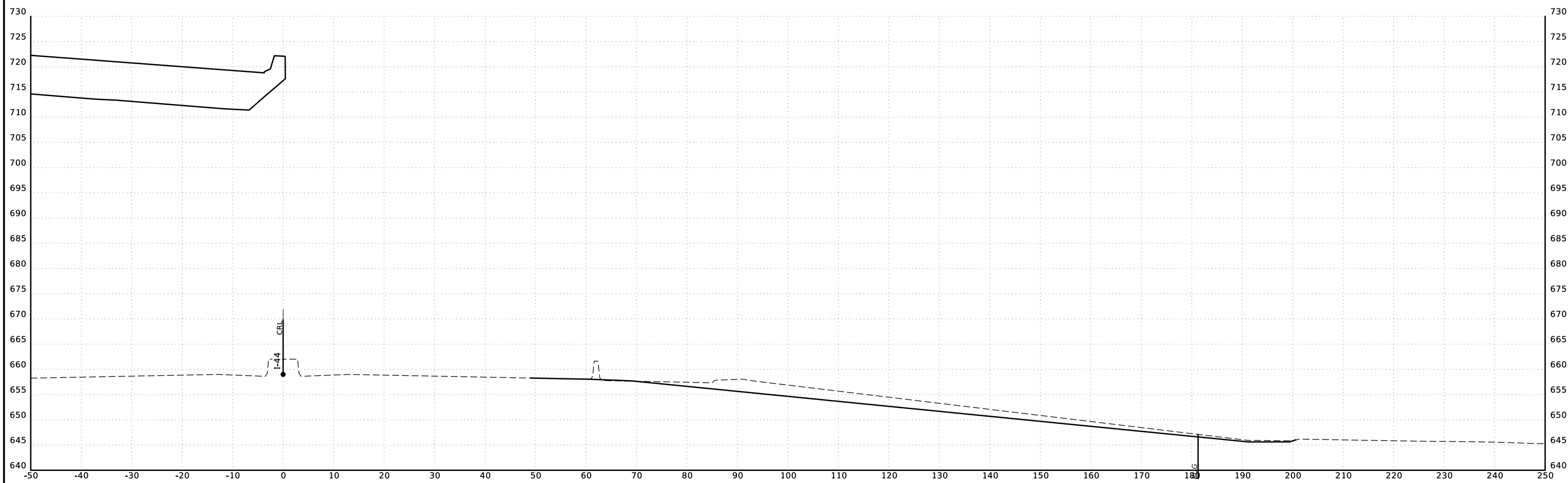

279+00

I-44 STA. 279+00 TO STA. 279+50

SCALE: 1"=10'

R/W UTILITY MEETING

MARCH 2021

3/4/2021

END AREAS (SF)

VOLUMES (CY)

PHASE 1

PHASE 2

PHASE 3

PHASE 4

PHASE 5

PHASE 1

PHASE 2

PHASE 3

PHASE 4

PHASE 5

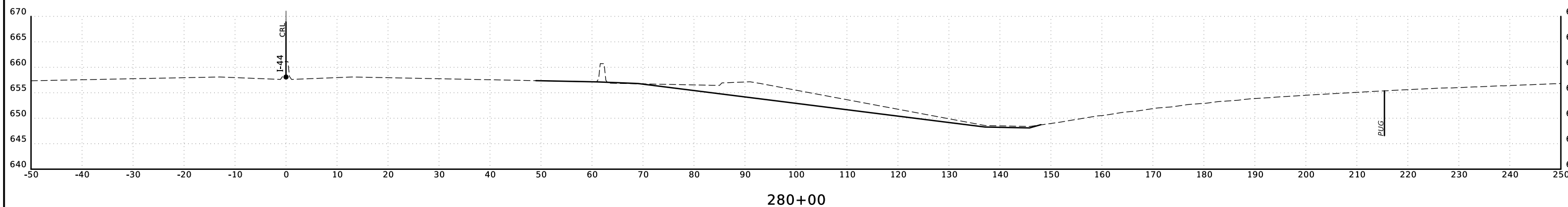
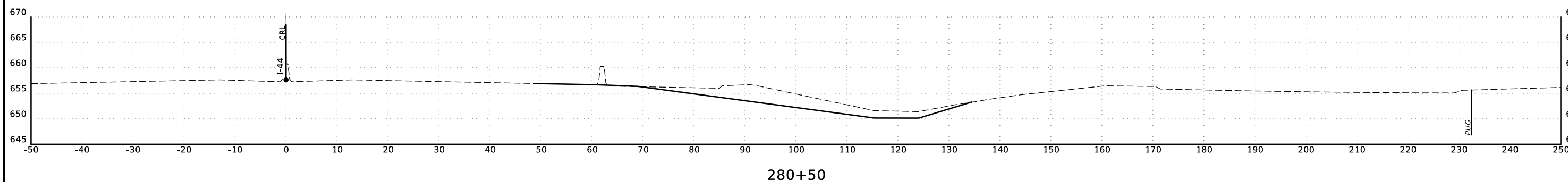
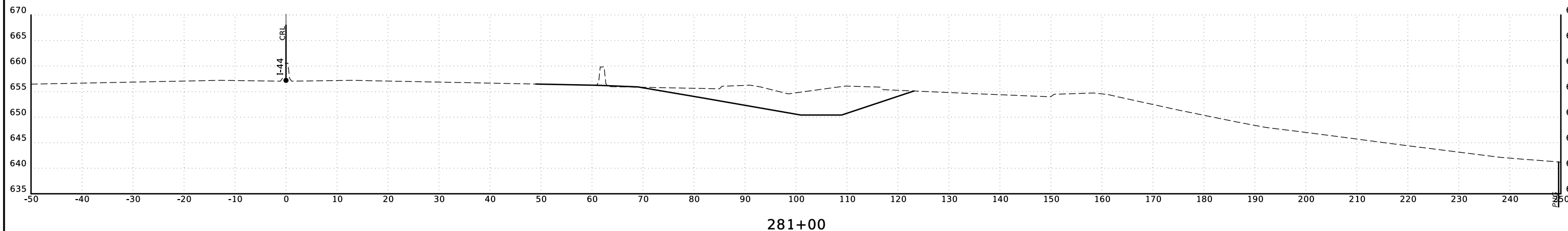

I-44 STA. 280+00 TO STA. 281+00

P:\FDB\1650-TUL\CIV\400315_000T_EC2123A_US75_Design-Working\CIV\MicroStation\3378811-WP5\3378811-CrossSections.dgn

SCALE: 1"=10'

END AREAS (SF)

PHASE 1 PHASE 2 PHASE 3 PHASE 4 PHASE 5

VOLUMES (CY)

PHASE 1 PHASE 2 PHASE 3 PHASE 4 PHASE 5

3/4/2021

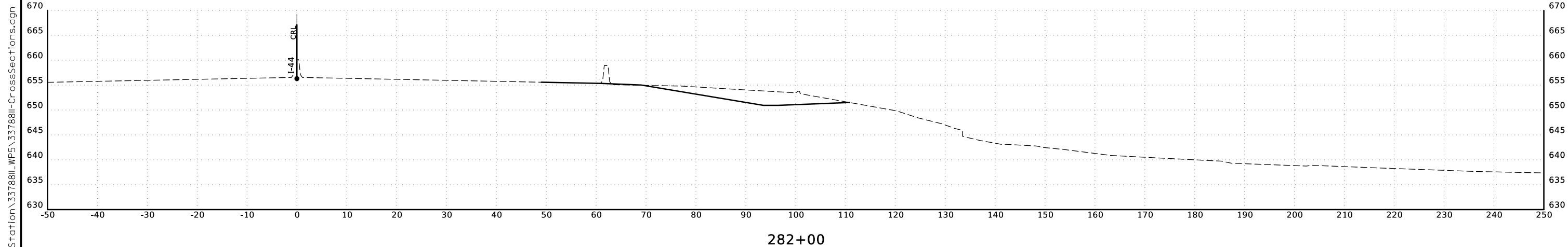

282+00

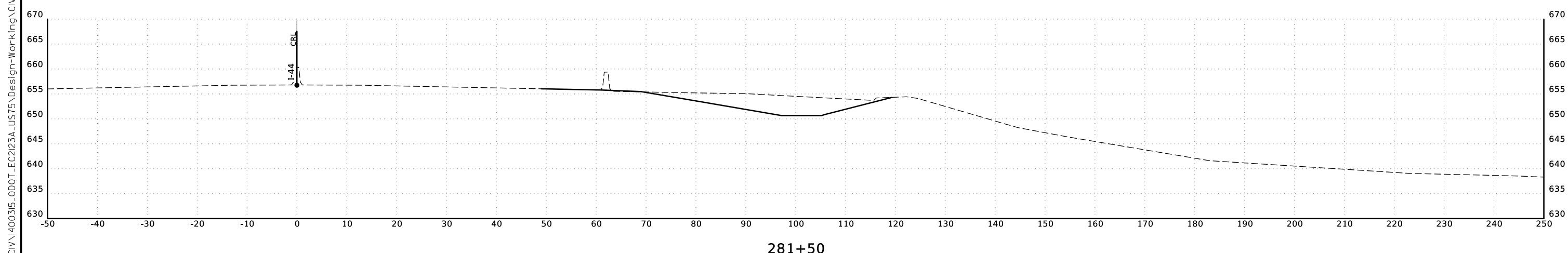

281+50

I-44 STA. 281+50 TO STA. 282+00

P:\FDB\1650-TUL\CIV\400315_000T_EC2123A_US75_Design-Working\CIV\MicroStation\33788II-CrossSections.dgn

SCALE: 1"=10'

END AREAS (SF)

PHASE 1 PHASE 2 PHASE 3 PHASE 4 PHASE 5

VOLUMES (CY)

PHASE 1 PHASE 2 PHASE 3 PHASE 4 PHASE 5

3/4/2021

P:\FDB\1650-TUL\CIV\400315_000T_EC2123A_US75_Design-Working\CIV\MicroStation\3378811-WP5\3378811-CrossSections.dgn

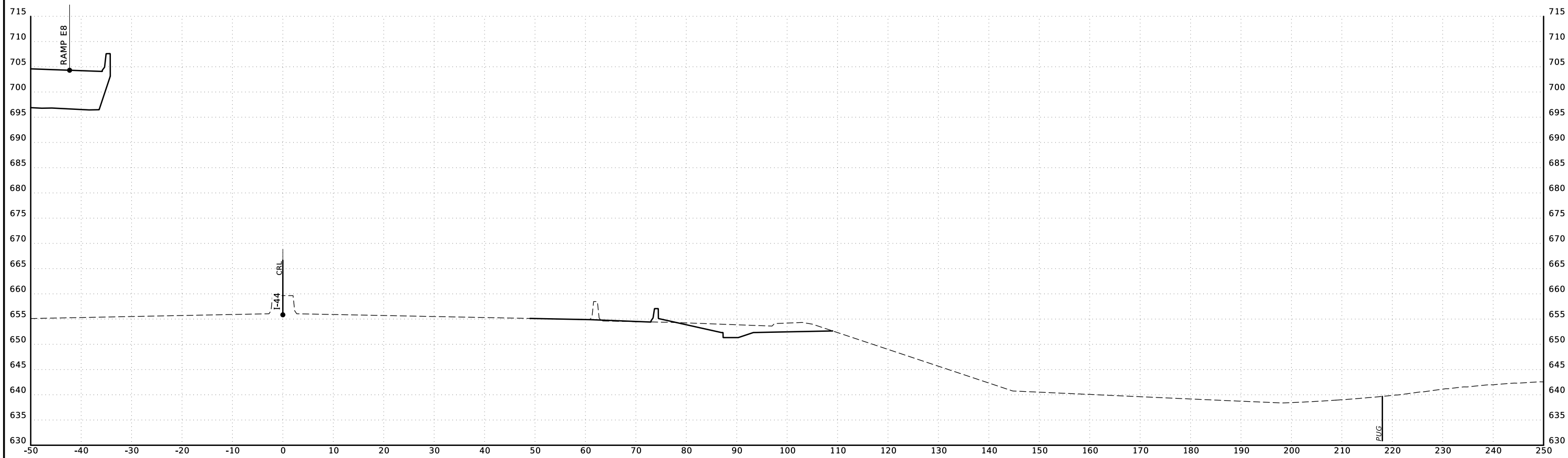

282+50

I-44 STA. 282+50 TO STA. 282+50

SCALE: 1"=10'

R/W UTILITY MEETING

MARCH 2021

END AREAS (SF)

PHASE 1 PHASE 2 PHASE 3 PHASE 4 PHASE 5

VOLUMES (CY)

PHASE 1 PHASE 2 PHASE 3 PHASE 4 PHASE 5

3/4/2021

P:\FDB\1650-TUL\CIV\400315_000T_EC2123A_US75_Design-Working\CIV\MicroStation\3378811-WP5\3378811-CrossSections.dgn

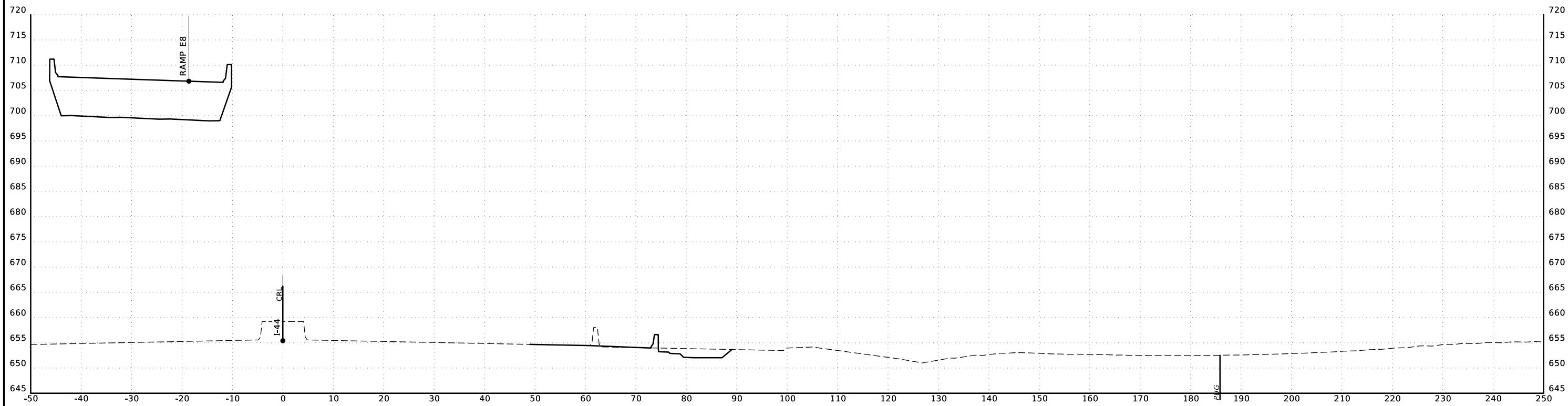

283+00

I-44 STA. 283+00 TO STA. 283+00

SCALE: 1"=10'

PHASE 1 PHASE 2 PHASE 3 PHASE 4 PHASE 5 PHASE 1 PHASE 2 PHASE 3 PHASE 4 PHASE 5

3/4/2021

P:\FDB\1650-TUL\CIV\400315_0001_EC2123A_US75\Design-Working\CIV\MicroStation\3378811-CrossSections.dgn

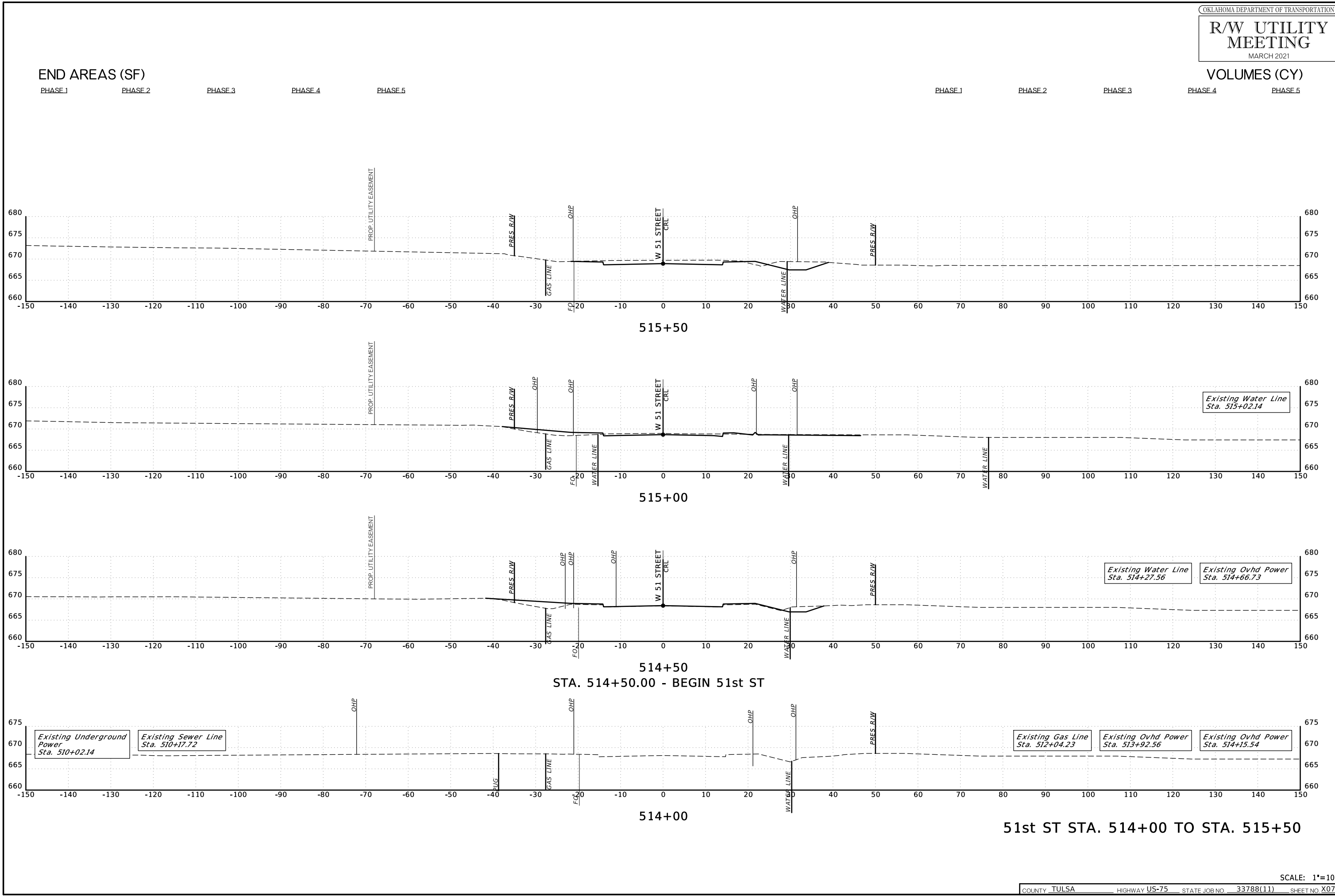

51st ST STA. 514+00 TO STA. 515+50

SCALE: 1"=10'

P:\FDB\1650-TUL\CIV\400315_000T_EC2123A_US75\Design-Working\CIV\MicroStation\337881-WP5\337881-CrossSections.dgn

END AREAS (SF)

VOLUMES (CY)

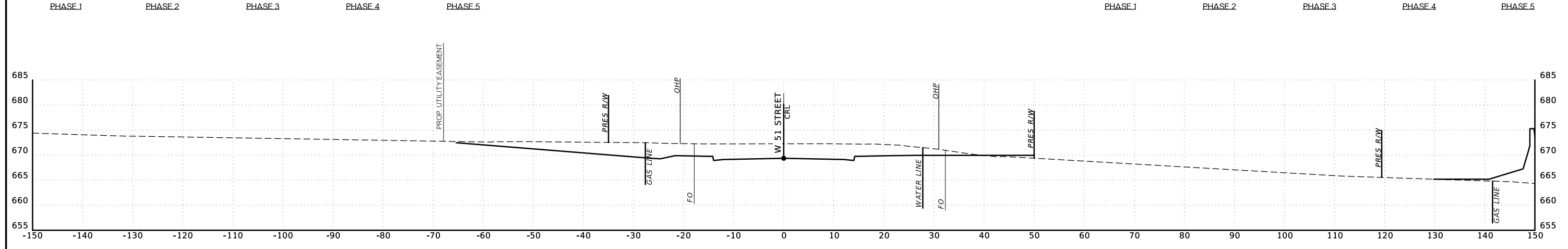

517+50

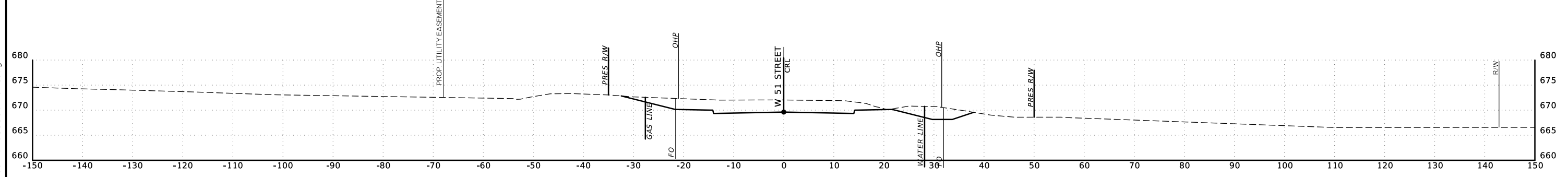

517+00

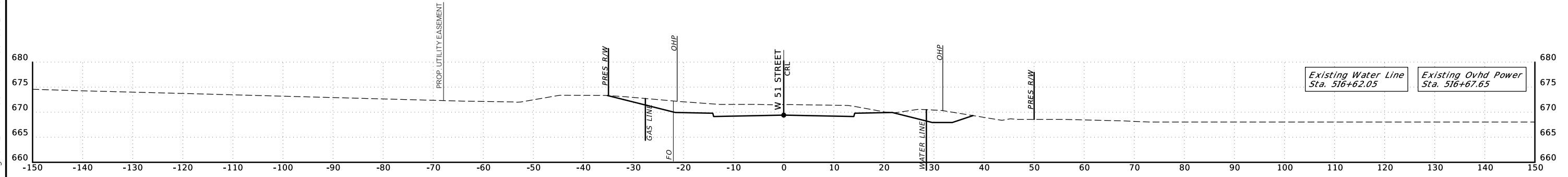

516+50

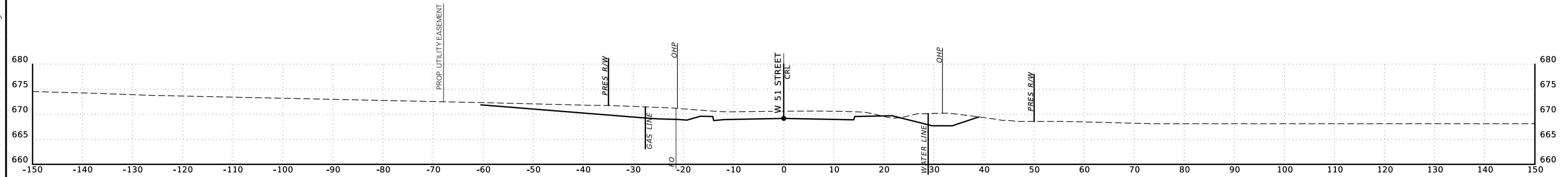

516+00

51st ST STA. 516+00 TO STA. 517+50

SCALE: 1"=10'

3/4/2021

END AREAS (SF)

VOLUMES (CY)

PHASE 1

PHASE 2

PHASE 3

PHASE 4

PHASE 5

PHASE 1

PHASE 2

PHASE 3

PHASE 4

PHASE 5

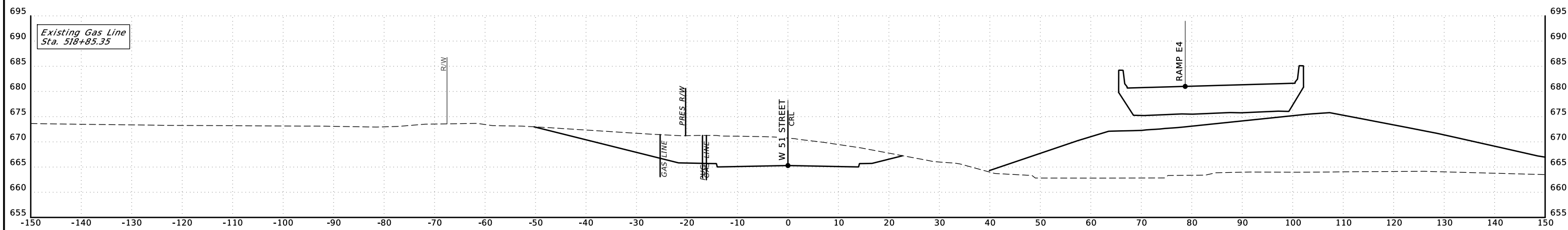

519+00

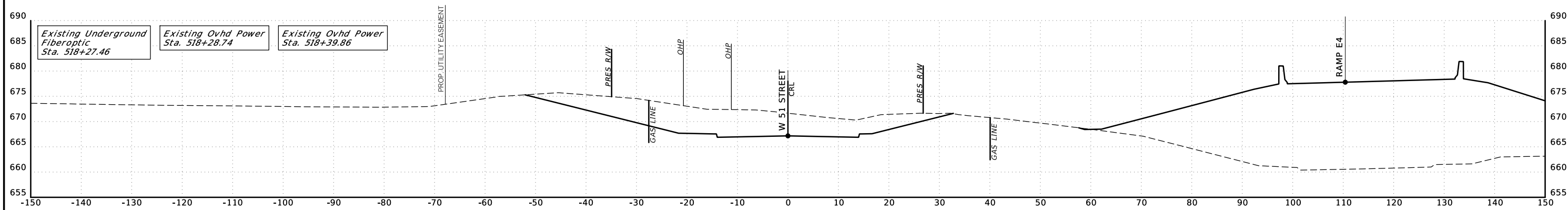

518+50

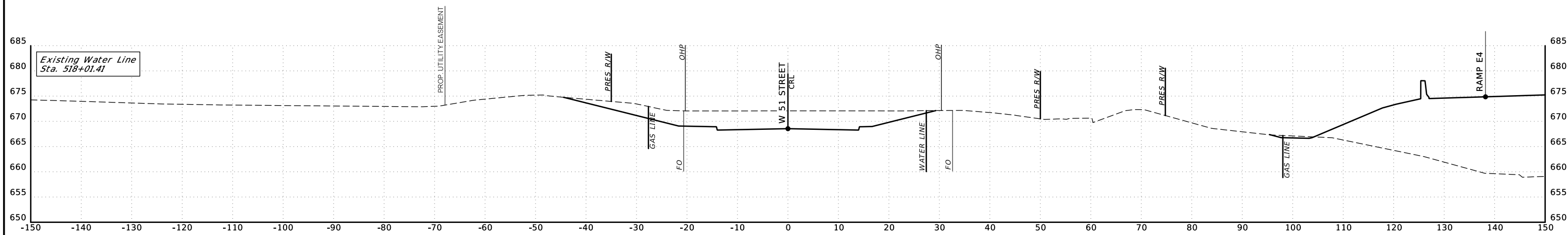

518+00

51st ST STA. 518+00 TO STA. 519+00

P:\FDB\1650-TUL\CIV\400315_ODOT_EC2123A_US75_Design-Working\CIV\MicroStation\3378811-WP5\3378811-CrossSections.dgn

R/W UTILITY MEETING

MARCH 2021

3/4/2021

END AREAS (SF)

VOLUMES (CY)

PHASE 1

PHASE 2

PHASE 3

PHASE 4

PHASE 5

PHASE 1

PHASE 2

PHASE 3

PHASE 4

PHASE 5

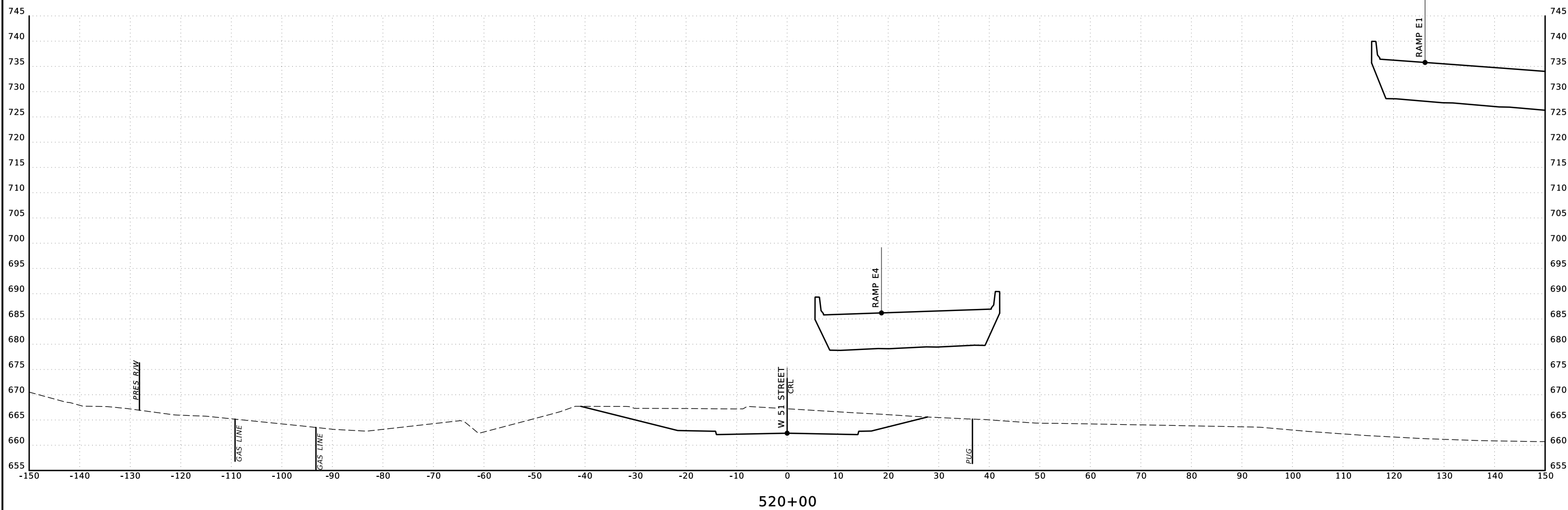

520+00

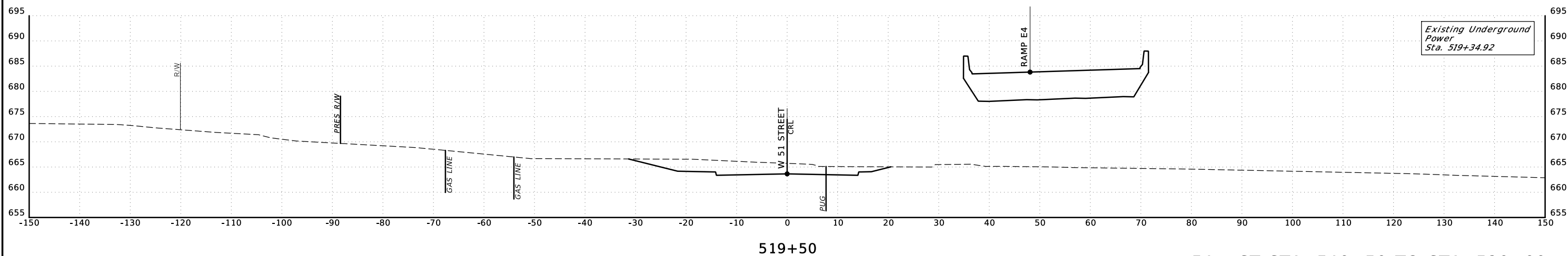

519+50

Existing Underground Power Sta. 519+34.92

51st ST STA. 519+50 TO STA. 520+00

P:\FDB\1650-TUL\CIV\400315_000T_EC2123A_US75_Design-Working\CIV\MicroStation\3378811-CrossSections.dgn

SCALE: 1"=10'

END AREAS (SF)

PHASE 1 PHASE 2 PHASE 3 PHASE 4 PHASE 5

VOLUMES (CY)

PHASE 1 PHASE 2 PHASE 3 PHASE 4 PHASE 5

3/4/2021

P:\FDB\1650-TUL\CIV\400315_000T_EC2123A_US75_Design-Working\CIV\MicroStation\3378811-WP5\3378811-CrossSections.dgn

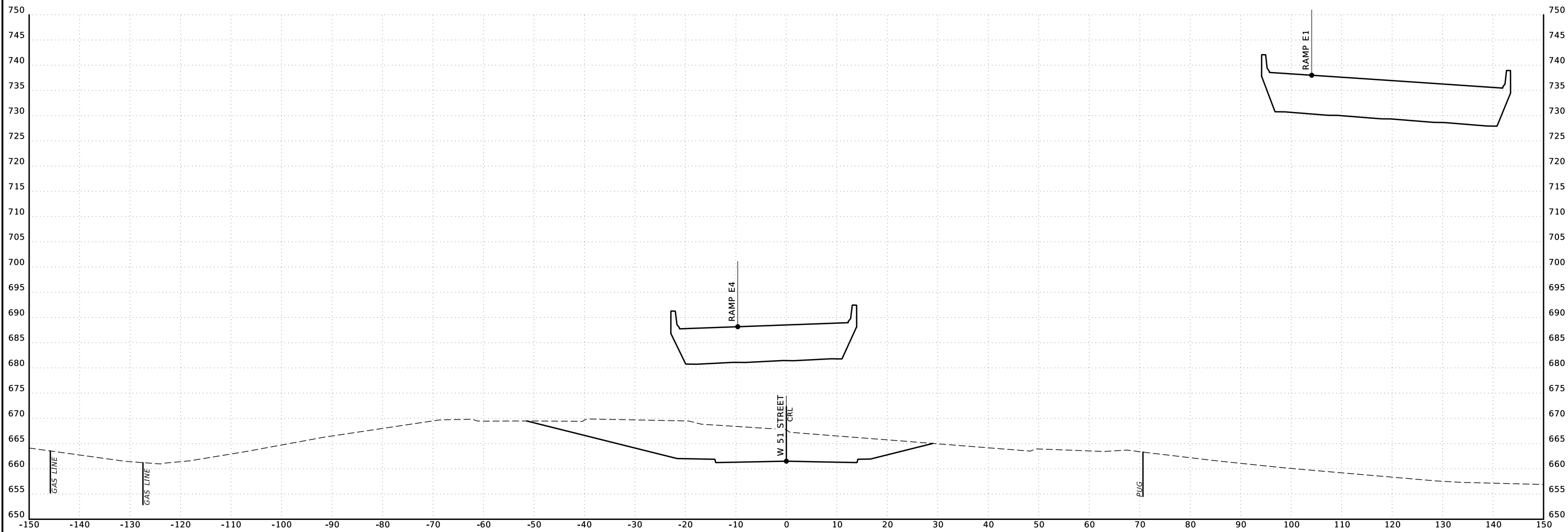

520+50

51st ST STA. 520+50 TO STA. 520+50

SCALE: 1"=10'

R/W UTILITY MEETING

MARCH 2021

END AREAS (SF)

PHASE 1 PHASE 2 PHASE 3 PHASE 4 PHASE 5

VOLUMES (CY)

PHASE 1 PHASE 2 PHASE 3 PHASE 4 PHASE 5

3/4/2021

P:\FDB\1650-TUL\CIV\400315_000T_EC2123A_US75_Design-Working\CIV\MicroStation\3378811-WP5\3378811-CrossSections.dgn

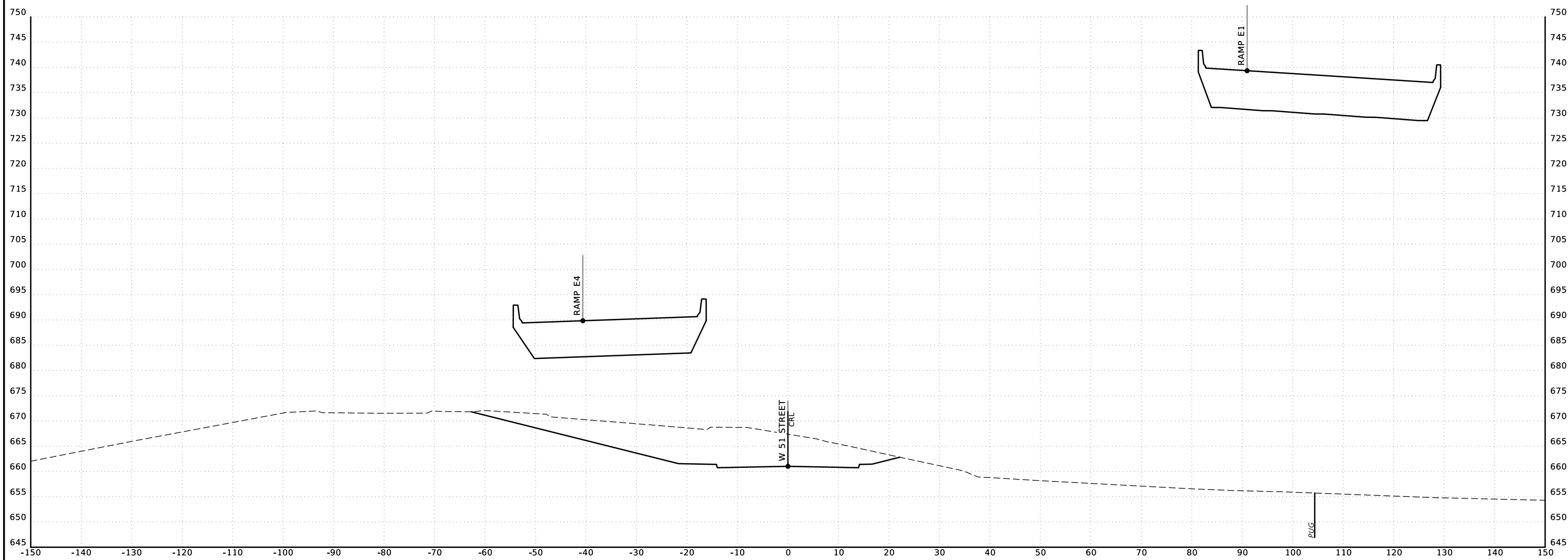

51st ST STA. 521+00 TO STA. 521+00

SCALE: 1"=10'

3/4/2021

R/W UTILITY MEETING

MARCH 2021

END AREAS (SF)

PHASE 1 PHASE 2 PHASE 3 PHASE 4 PHASE 5

VOLUMES (CY)

PHASE 1 PHASE 2 PHASE 3 PHASE 4 PHASE 5

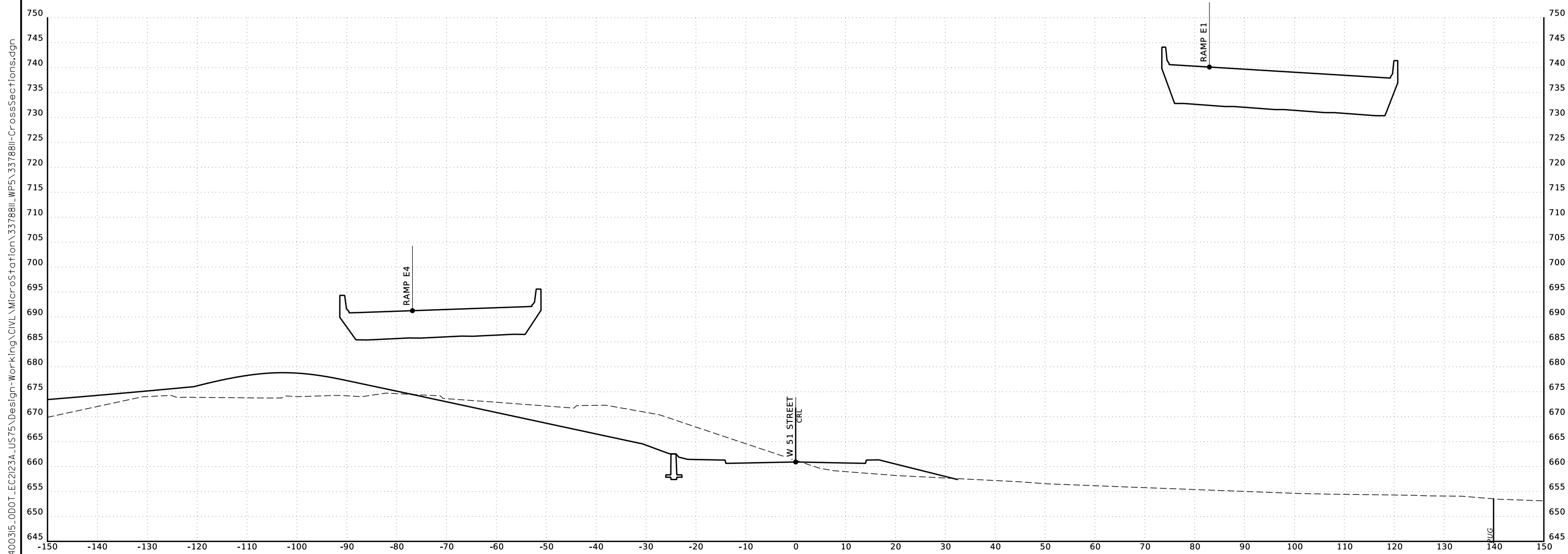

521+50

51st ST STA. 521+50 TO STA. 521+50

P:\FDB\1650-TUL\CIV\400315_000T_EC2123A_US75_Design-Working\CIV\MicroStation\3378811-WP5\3378811-CrossSections.dgn

SCALE: 1"=10'

3/4/2021

R/W UTILITY MEETING

MARCH 2021

END AREAS (SF)

PHASE 1 PHASE 2 PHASE 3 PHASE 4 PHASE 5

VOLUMES (CY)

PHASE 1 PHASE 2 PHASE 3 PHASE 4 PHASE 5

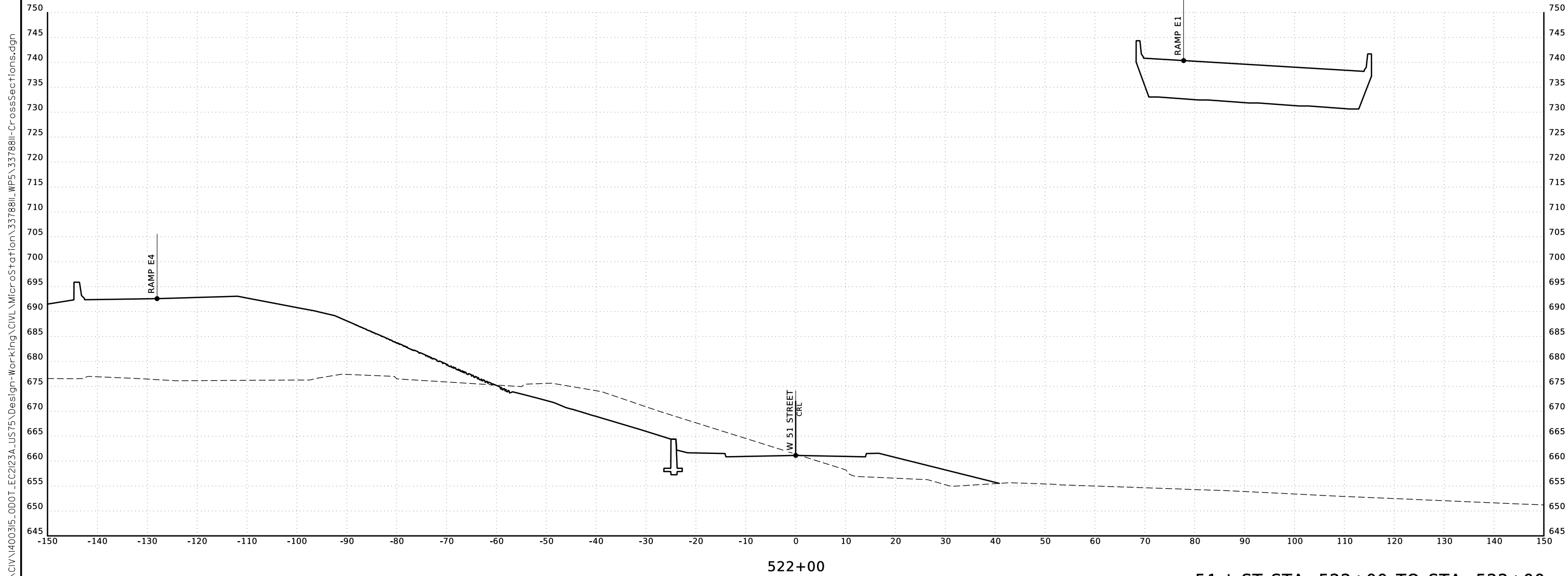

51st ST STA. 522+00 TO STA. 522+00

P:\FDB\1650-TUL\CIV\400315_000T_EC2123A_US75_Design-Working\CIV\MicroStation\3378811-WP5\3378811-CrossSections.dgn

SCALE: 1"=10'

END AREAS (SF)

PHASE 1 PHASE 2 PHASE 3 PHASE 4 PHASE 5

VOLUMES (CY)

PHASE 1 PHASE 2 PHASE 3 PHASE 4 PHASE 5

3/4/2021

P:\FDB\1650-TUL\CIV\400315_000T_EC2123A_US75_Design-Working\CIV\MicroStation\3378811-WP5\3378811-CrossSections.dgn

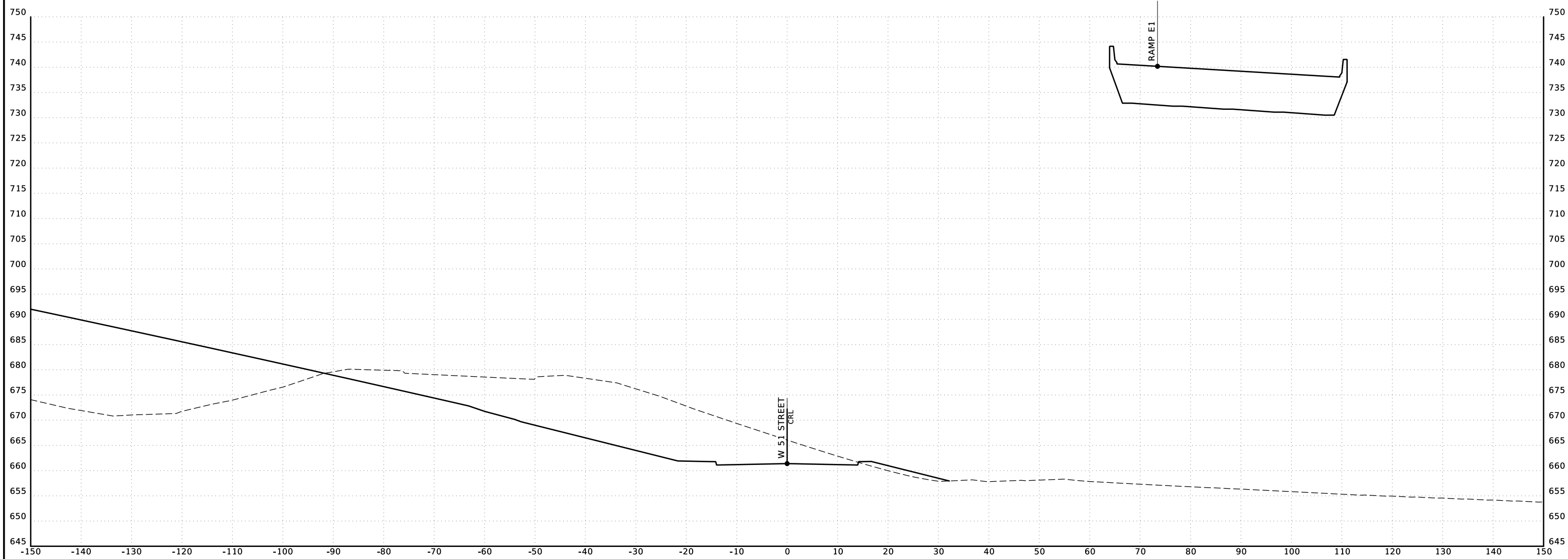

522+50

51st ST STA. 522+50 TO STA. 522+50

SCALE: 1"=10'

R/W UTILITY MEETING

MARCH 2021

END AREAS (SF)

PHASE 1 PHASE 2 PHASE 3 PHASE 4 PHASE 5

VOLUMES (CY)

PHASE 1 PHASE 2 PHASE 3 PHASE 4 PHASE 5

3/4/2021

P:\FDB\1650-TUL\CIV\400315_000T_EC2123A_US75_Design-Working\CIV\MicroStation\3378811-WP5\3378811-CrossSections.dgn

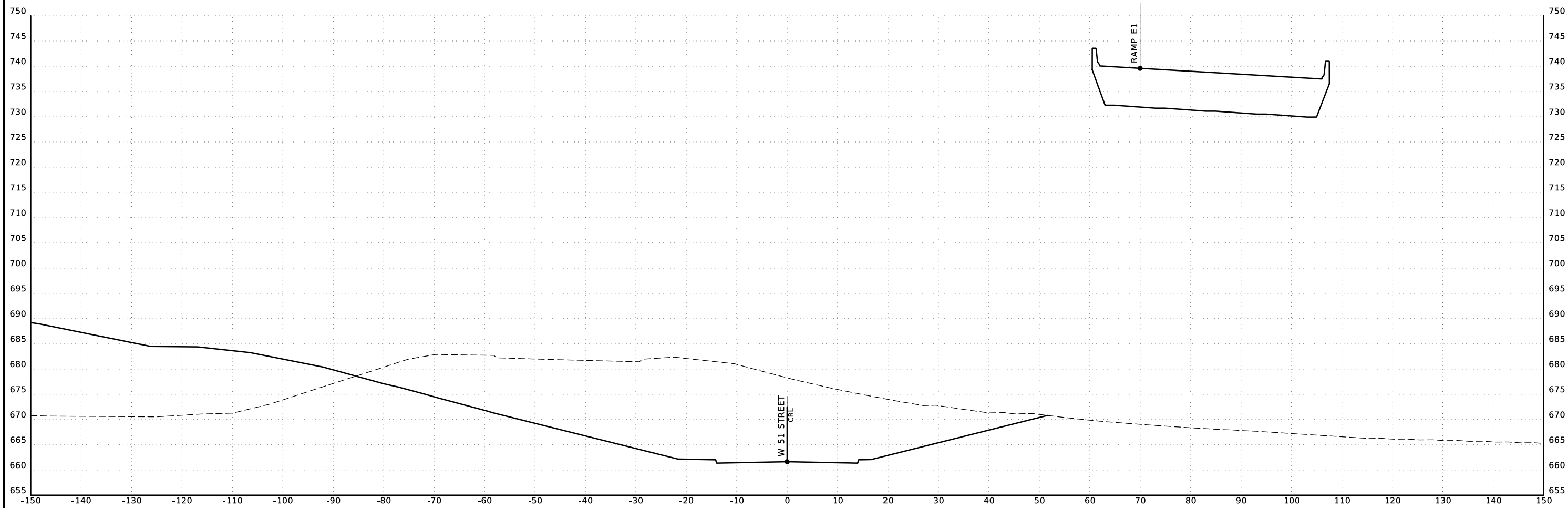

523+00

51st ST STA. 523+00 TO STA. 523+00

SCALE: 1"=10'

END AREAS (SF)

PHASE 1 PHASE 2 PHASE 3 PHASE 4 PHASE 5

VOLUMES (CY)

PHASE 1 PHASE 2 PHASE 3 PHASE 4 PHASE 5

3/4/2021

P:\FDB\1650-TUL\CIV\400315_000T_EC2123A_US75_Design-Working\CIV\MicroStation\3378811-WP5\3378811-CrossSections.dgn

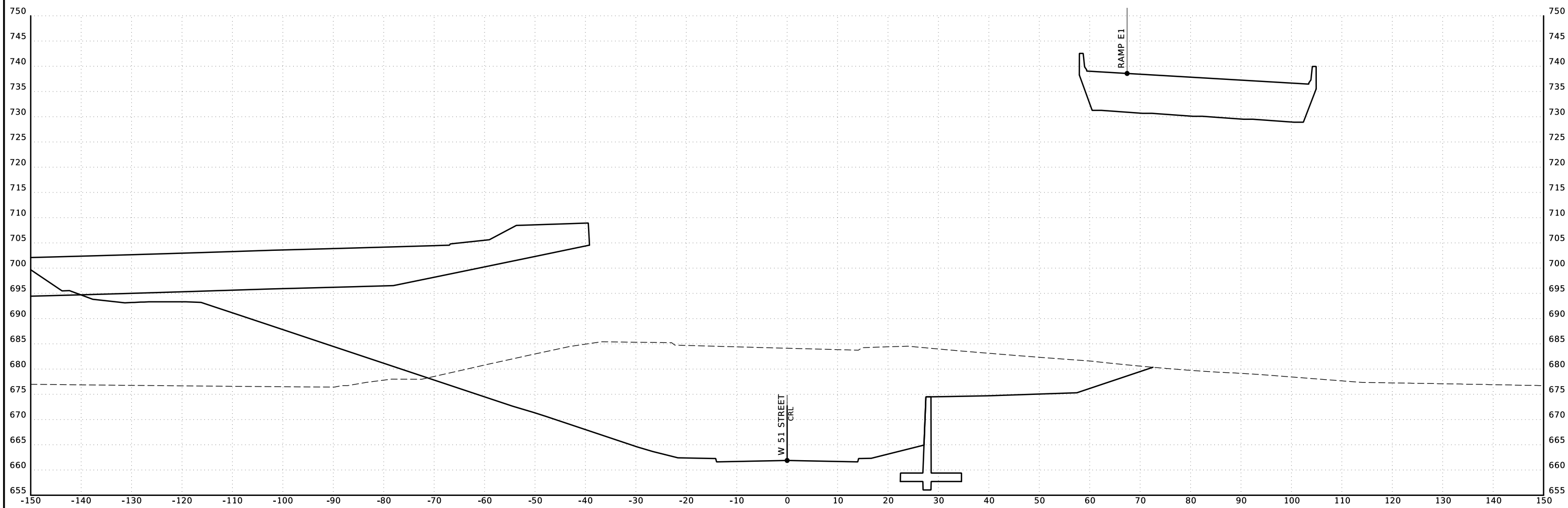

523+50

51st ST STA. 523+50 TO STA. 523+50

SCALE: 1"=10'

END AREAS (SF)

PHASE 1 PHASE 2 PHASE 3 PHASE 4 PHASE 5

VOLUMES (CY)

PHASE 1 PHASE 2 PHASE 3 PHASE 4 PHASE 5

3/4/2021

P:\FDB\1650-TUL\CIV\400315_000T_EC2123A_US75_Design-Working\CIV\MicroStation\3378811-WP5\3378811-CrossSections.dgn

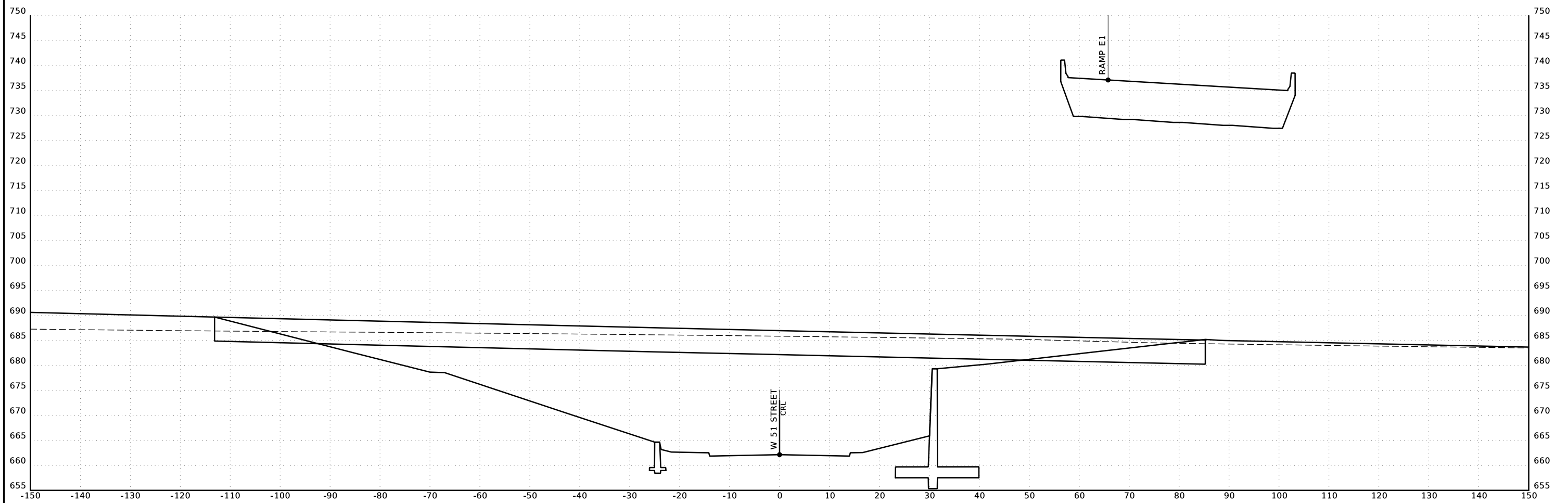

524+00

51st ST STA. 524+00 TO STA. 524+00

SCALE: 1"=10'

END AREAS (SF)

PHASE 1 PHASE 2 PHASE 3 PHASE 4 PHASE 5

VOLUMES (CY)

PHASE 1 PHASE 2 PHASE 3 PHASE 4 PHASE 5

3/4/2021

P:\FDB\1650-TUL\CIV\400315_000T_EC2123A_US75_Design-Working\CIV\MicroStation\3378811-WP5\3378811-CrossSections.dgn

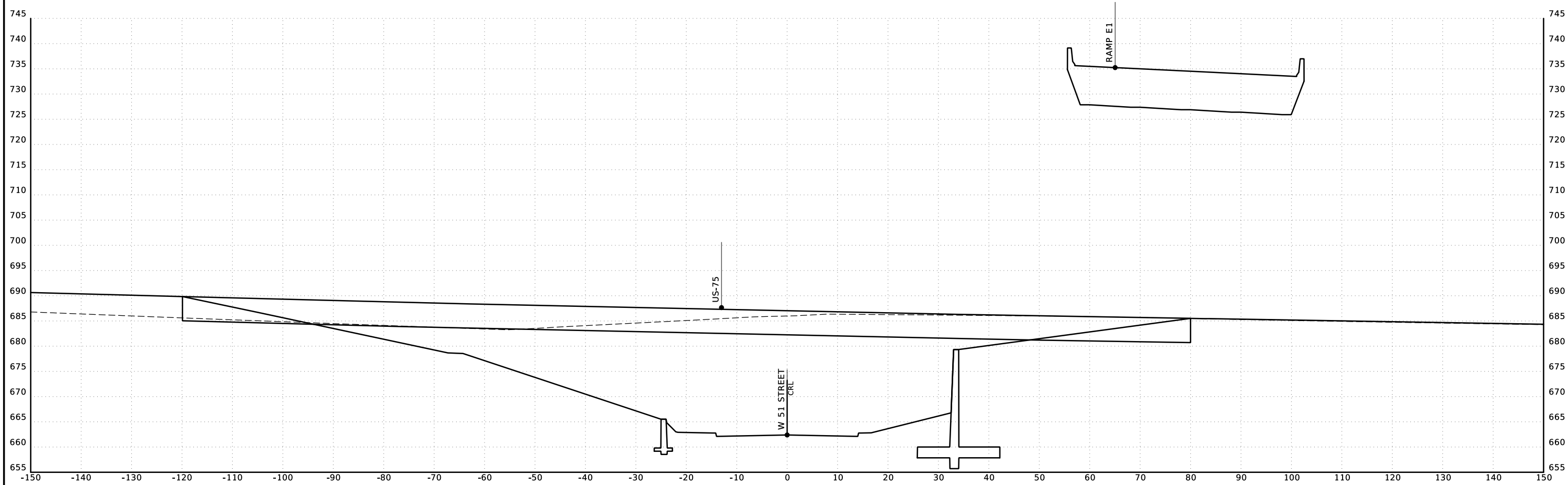

524+50

51st ST STA. 524+50 TO STA. 524+50

SCALE: 1"=10'

END AREAS (SF)

PHASE 1 PHASE 2 PHASE 3 PHASE 4 PHASE 5

VOLUMES (CY)

PHASE 1 PHASE 2 PHASE 3 PHASE 4 PHASE 5

3/4/2021

P:\FDB\1650-TUL\CIV\1400315_000T_EC2123A_US75_Design-Working\CIV\MicroStation\3378811-WP5\3378811-CrossSections.dgn

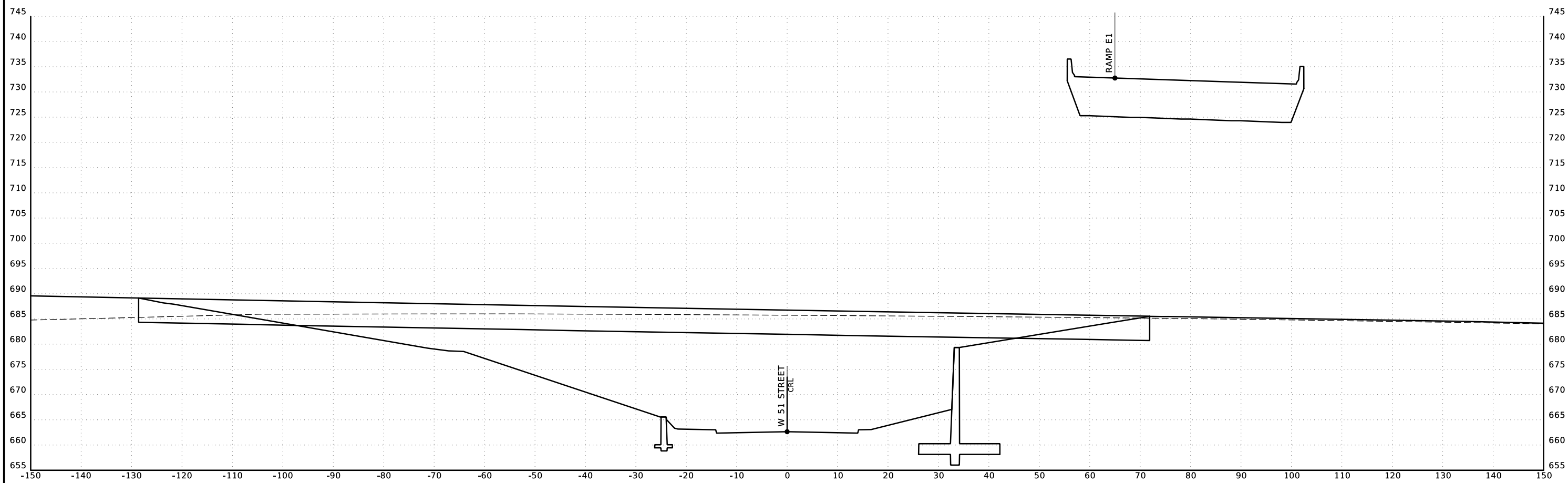

525+00

51st ST STA. 525+00 TO STA. 525+00

SCALE: 1"=10'

R/W UTILITY MEETING

MARCH 2021

END AREAS (SF)

PHASE 1 PHASE 2 PHASE 3 PHASE 4 PHASE 5

VOLUMES (CY)

PHASE 1 PHASE 2 PHASE 3 PHASE 4 PHASE 5

3/4/2021

P:\FDB\1650-TUL\CIV\1400315_000T_EC2123A_US75_Design-Working\CIV\MicroStation\3378811-WP5\3378811-CrossSections.dgn

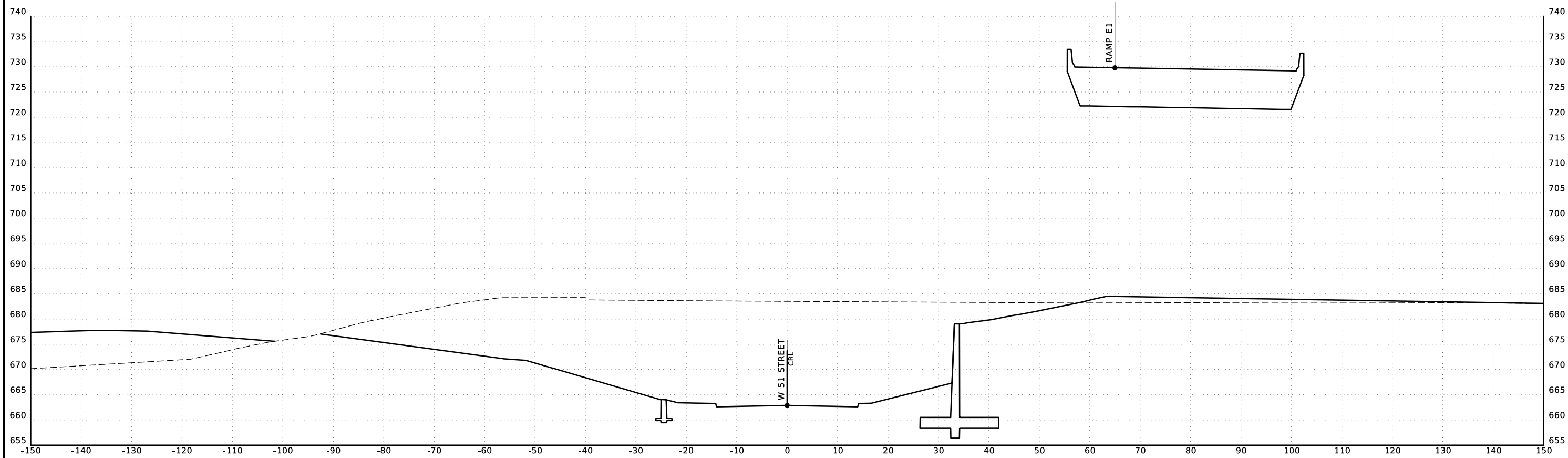

525+50

51st ST STA. 525+50 TO STA. 525+50

SCALE: 1"=10'

END AREAS (SF)

PHASE 1 PHASE 2 PHASE 3 PHASE 4 PHASE 5

VOLUMES (CY)

PHASE 1 PHASE 2 PHASE 3 PHASE 4 PHASE 5

3/4/2021

P:\FDB\1650-TUL\CIV\400315_000T_EC2123A_US75_Design-Working\CIV\MicroStation\3378811-WP5\3378811-CrossSections.dgn

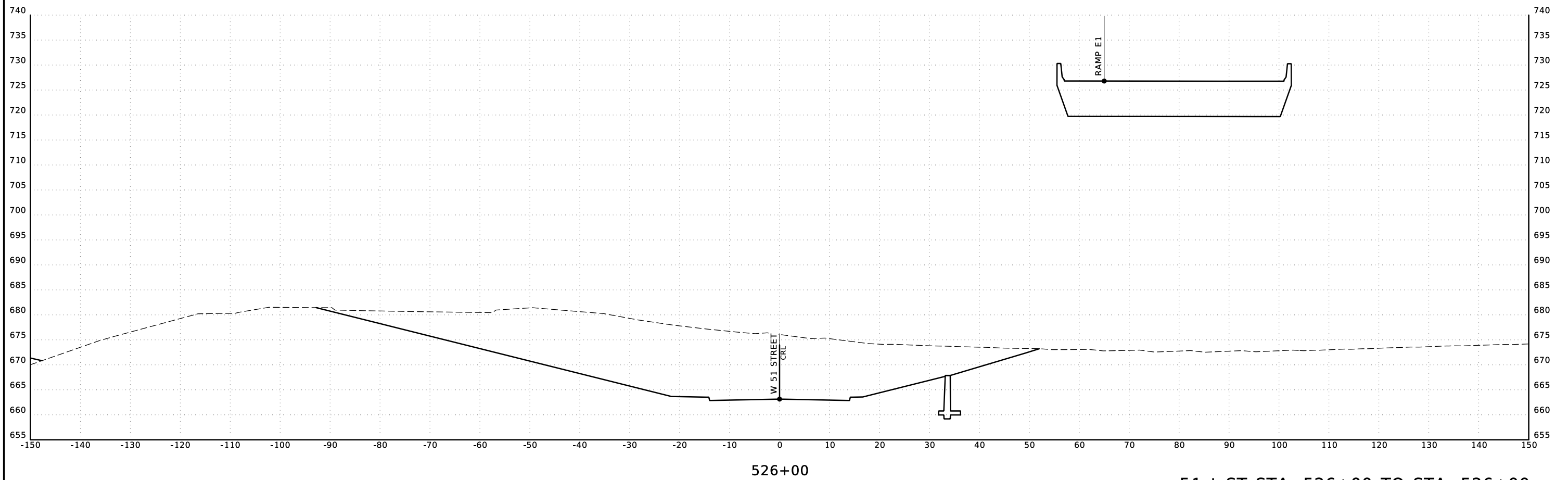

51st ST STA. 526+00 TO STA. 526+00

SCALE: 1"=10'

END AREAS (SF)

PHASE 1 PHASE 2 PHASE 3 PHASE 4 PHASE 5

VOLUMES (CY)

PHASE 1 PHASE 2 PHASE 3 PHASE 4 PHASE 5

3/4/2021

P:\FDB\1650-TUL\CIV\1400315_000T_EC2123A_US75_Design-Working\CIV\MicroStation\3378811-WP5\3378811-CrossSections.dgn

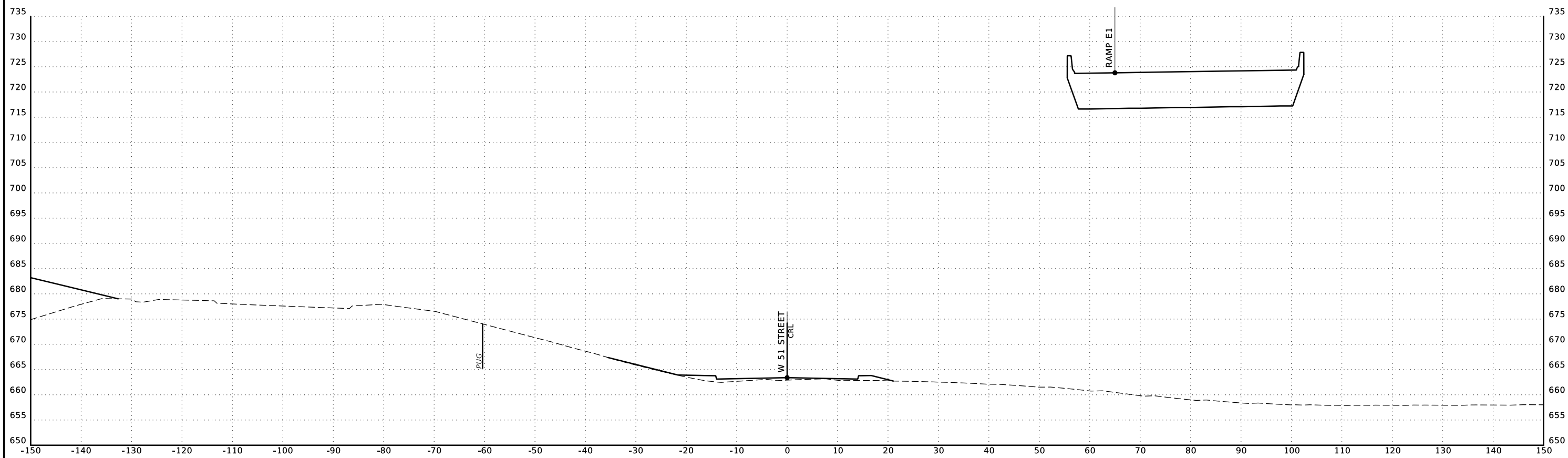

526+50

51st ST STA. 526+50 TO STA. 526+50

SCALE: 1"=10'

3/4/2021

P:\FDB\1650-TUL\CIV\400315_000T_EC2123A_US75_Design-Working\CIV\MicroStation\3378811-WP5\3378811-CrossSections.dgn

R/W UTILITY MEETING

MARCH 2021

END AREAS (SF)

PHASE 1 PHASE 2 PHASE 3 PHASE 4 PHASE 5

VOLUMES (CY)

PHASE 1 PHASE 2 PHASE 3 PHASE 4 PHASE 5

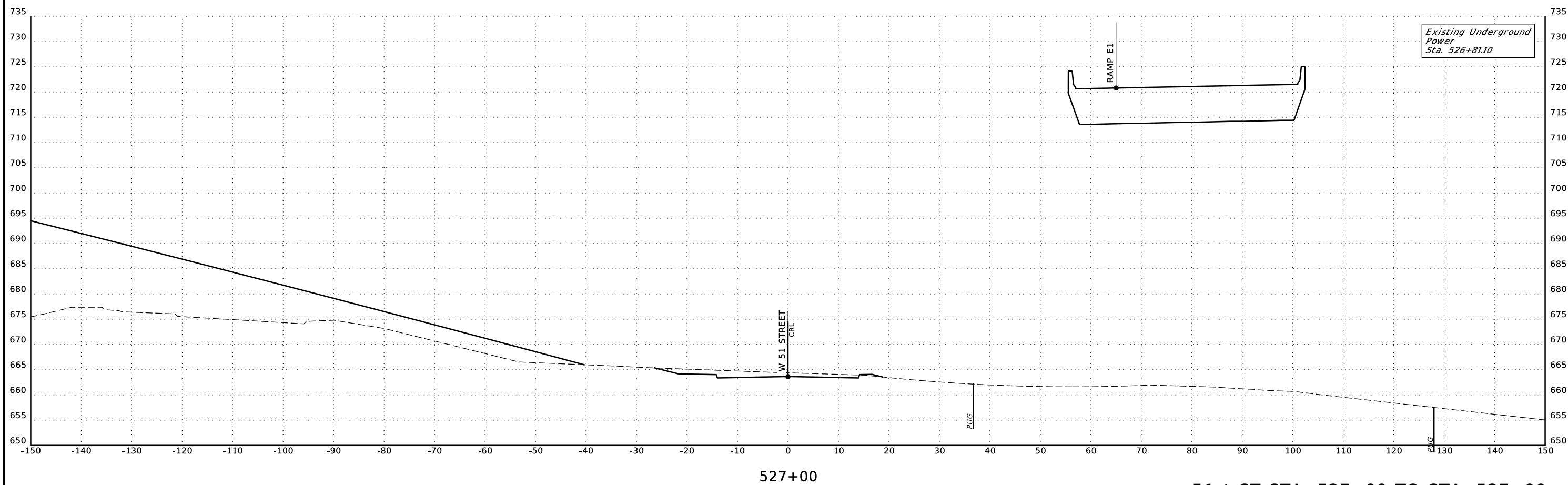

51st ST STA. 527+00 TO STA. 527+00

SCALE: 1"=10'

END AREAS (SF)

PHASE 1 PHASE 2 PHASE 3 PHASE 4 PHASE 5

VOLUMES (CY)

PHASE 1 PHASE 2 PHASE 3 PHASE 4 PHASE 5

3/4/2021

P:\FDB\1650-TUL\CIV\400315_000T_EC2123A_US75_Design-Working\CIV\MicroStation\3378811-WP5\3378811-CrossSections.dgn

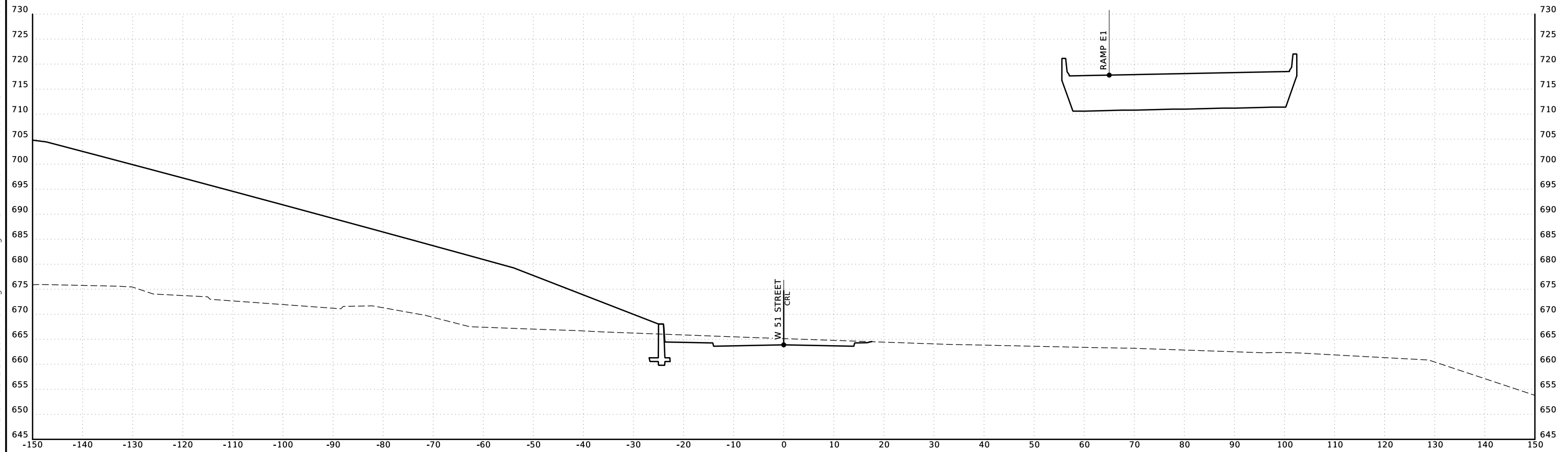

527+50

51st ST STA. 527+50 TO STA. 527+50

SCALE: 1"=10'

3/4/2021

P:\FDB\1650-TUL\CIV\400315_000T_EC2123A_US75_Design-Working\CIV\MicroStation\3378811-WP5\3378811-CrossSections.dgn

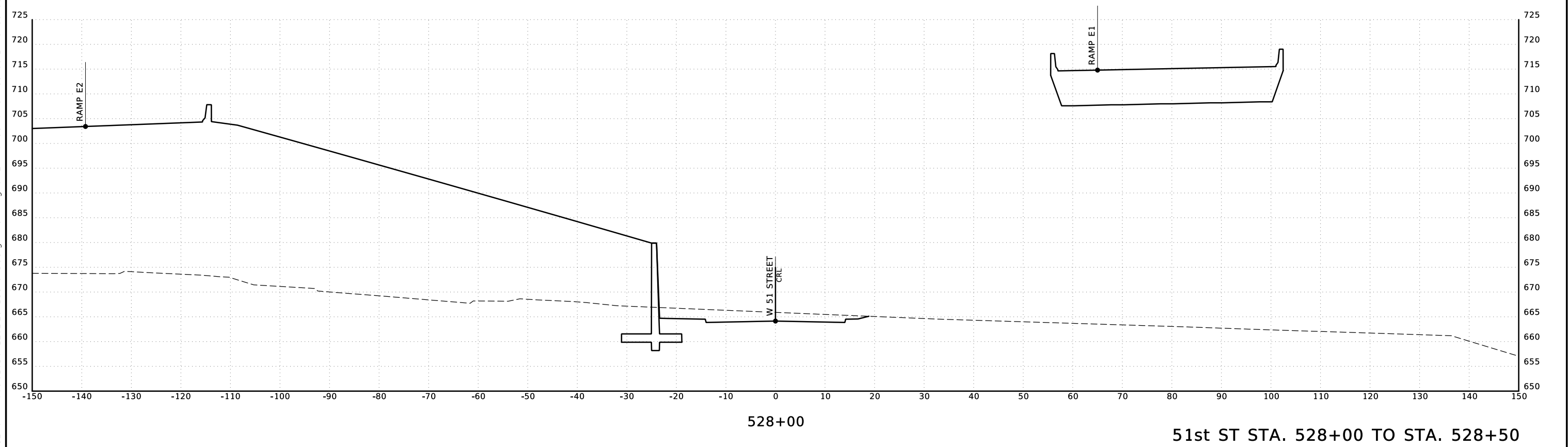
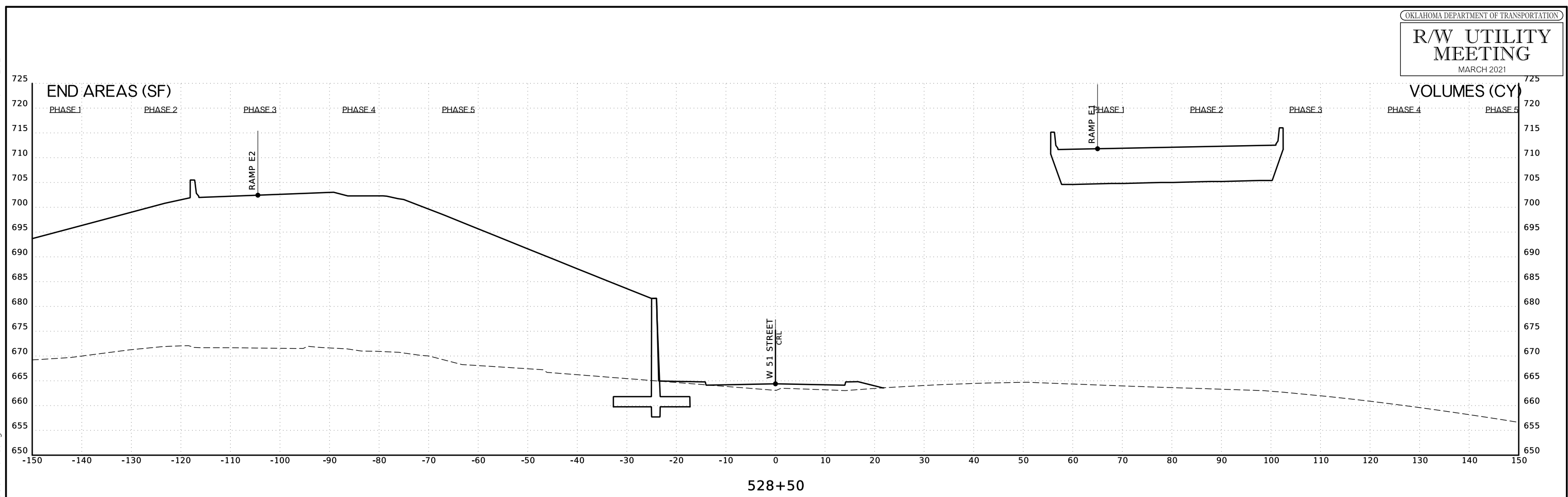

51st ST STA. 528+00 TO STA. 528+50

SCALE: 1"=10'

P:\FDB\1650-TUL\CIV\400315_000T_EC2123A_US75_Design-Working\CIV\MicroStation\3378811-WP5\3378811-CrossSections.dgn

END AREAS (SF)

PHASE 1 PHASE 2 PHASE 3 PHASE 4 PHASE 5

VOLUMES (CY)

PHASE 1 PHASE 2 PHASE 3 PHASE 4 PHASE 5

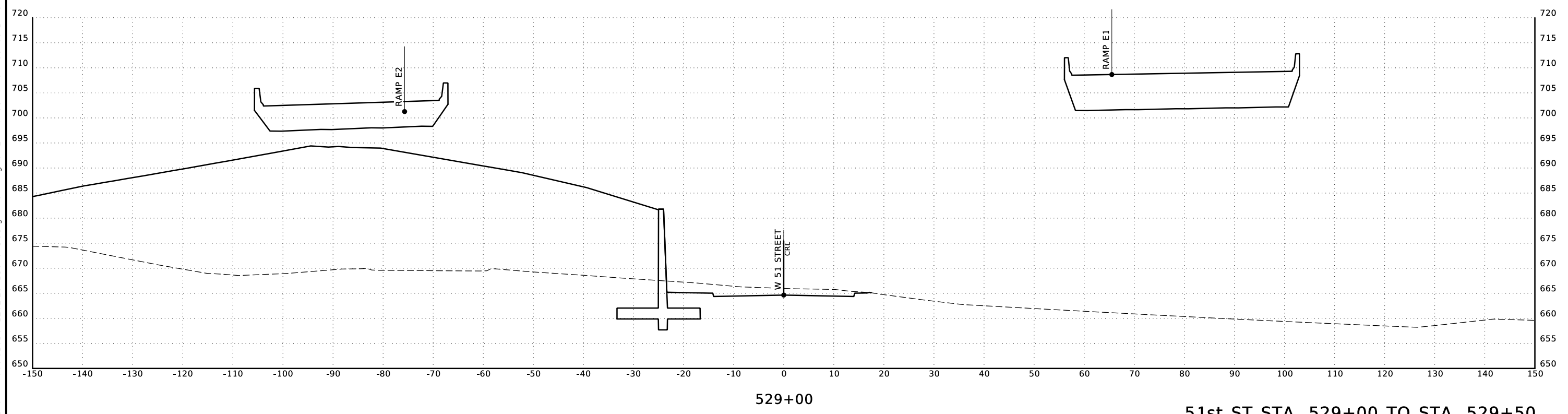
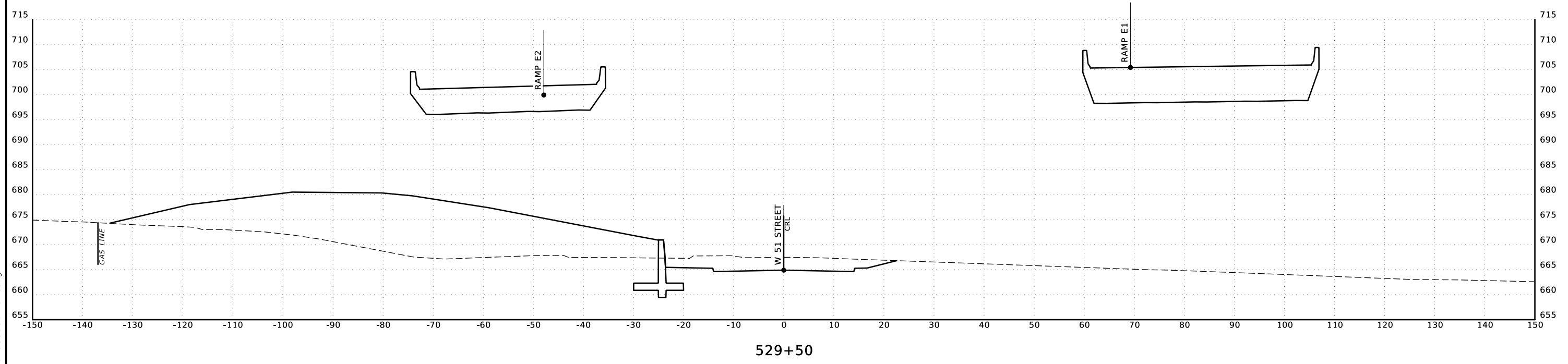

51st ST STA. 529+00 TO STA. 529+50

SCALE: 1"=10'

END AREAS (SF)

PHASE 1 PHASE 2 PHASE 3 PHASE 4 PHASE 5

VOLUMES (CY)

PHASE 1 PHASE 2 PHASE 3 PHASE 4 PHASE 5

P:\FDB\1650-TUL\CIV\400315_000T_EC2123A_US75_Design-Working\CIV\MicroStation\3378811-WP5\3378811-CrossSections.dgn

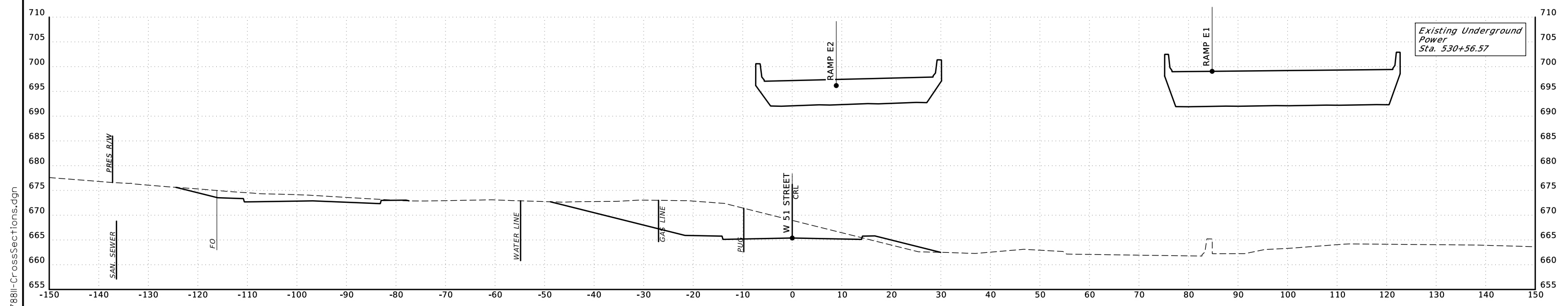

530+50

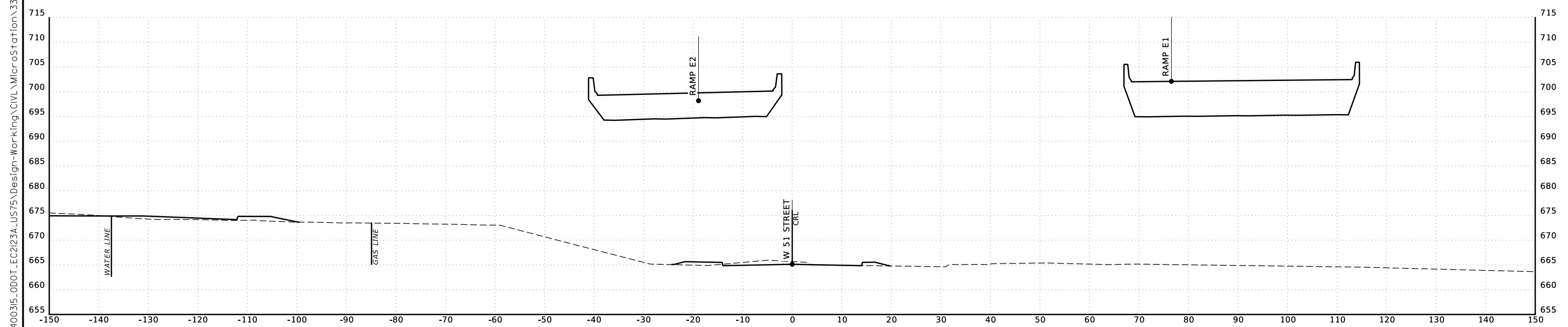

530+00

51st ST STA. 530+00 TO STA. 530+50

SCALE: 1"=10'

END AREAS (SF)

PHASE 1 PHASE 2 PHASE 3 PHASE 4 PHASE 5

VOLUMES (CY)

PHASE 1 PHASE 2 PHASE 3 PHASE 4 PHASE 5

P:\FDB\1650-TUL\CIV\400315-000T_EC2123A_US75\Design-Working\CIV\MicroStation\337881I-CrossSections.dgn

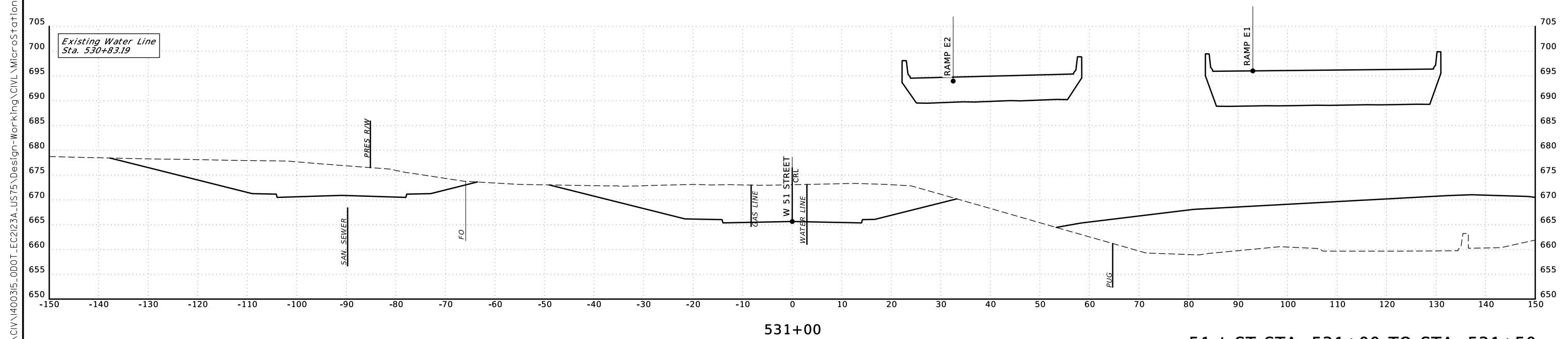
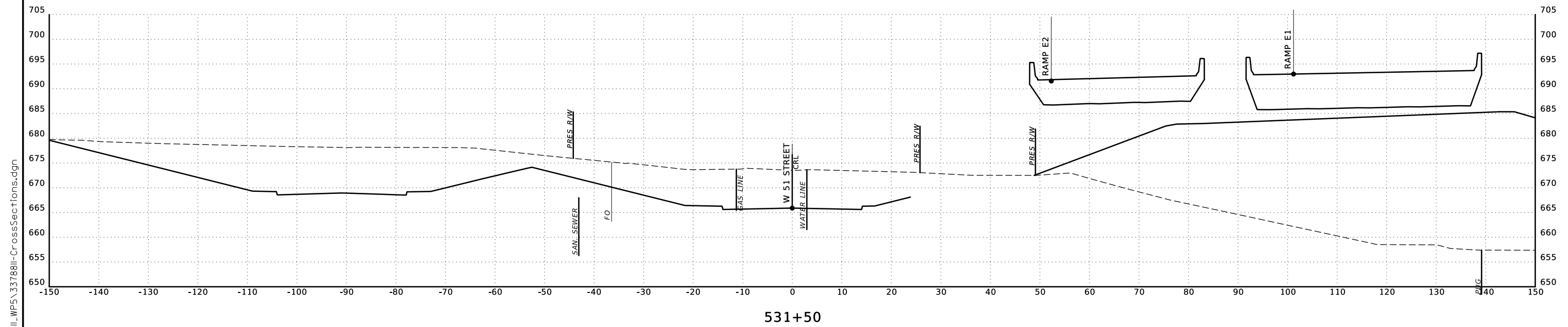

51st ST STA. 531+00 TO STA. 531+50

SCALE: 1"=10'

P:\FDB\1650-TUL\CIV\1400315_000T_EC2123A_US75_Design-Working\CIV\MicroStation\3378811-WP5\3378811-CrossSections.dgn

END AREAS (SF)

VOLUMES (CY)

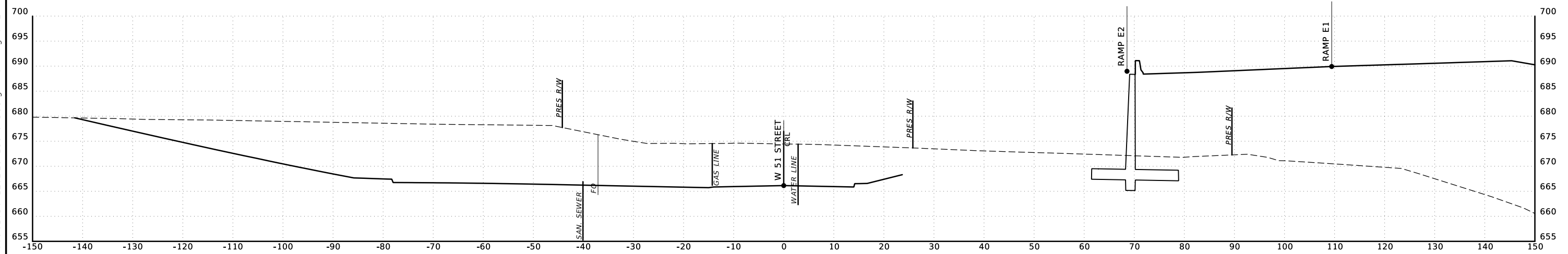
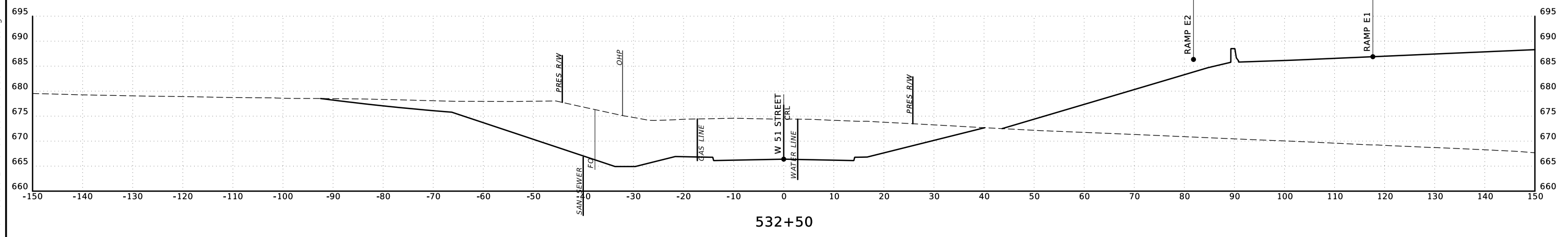
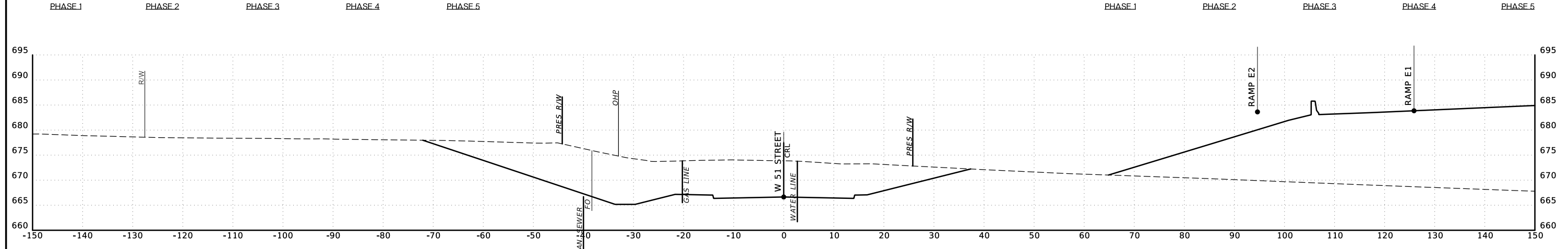

51st ST STA. 532+00 TO STA. 533+00

SCALE: 1"=10'

3/4/2021

P:\FDB\1650-TUL\CIV\400315_000T_EC2123A_US75_Design-Working\CIV\MicroStation\33788II-CrossSections.dgn

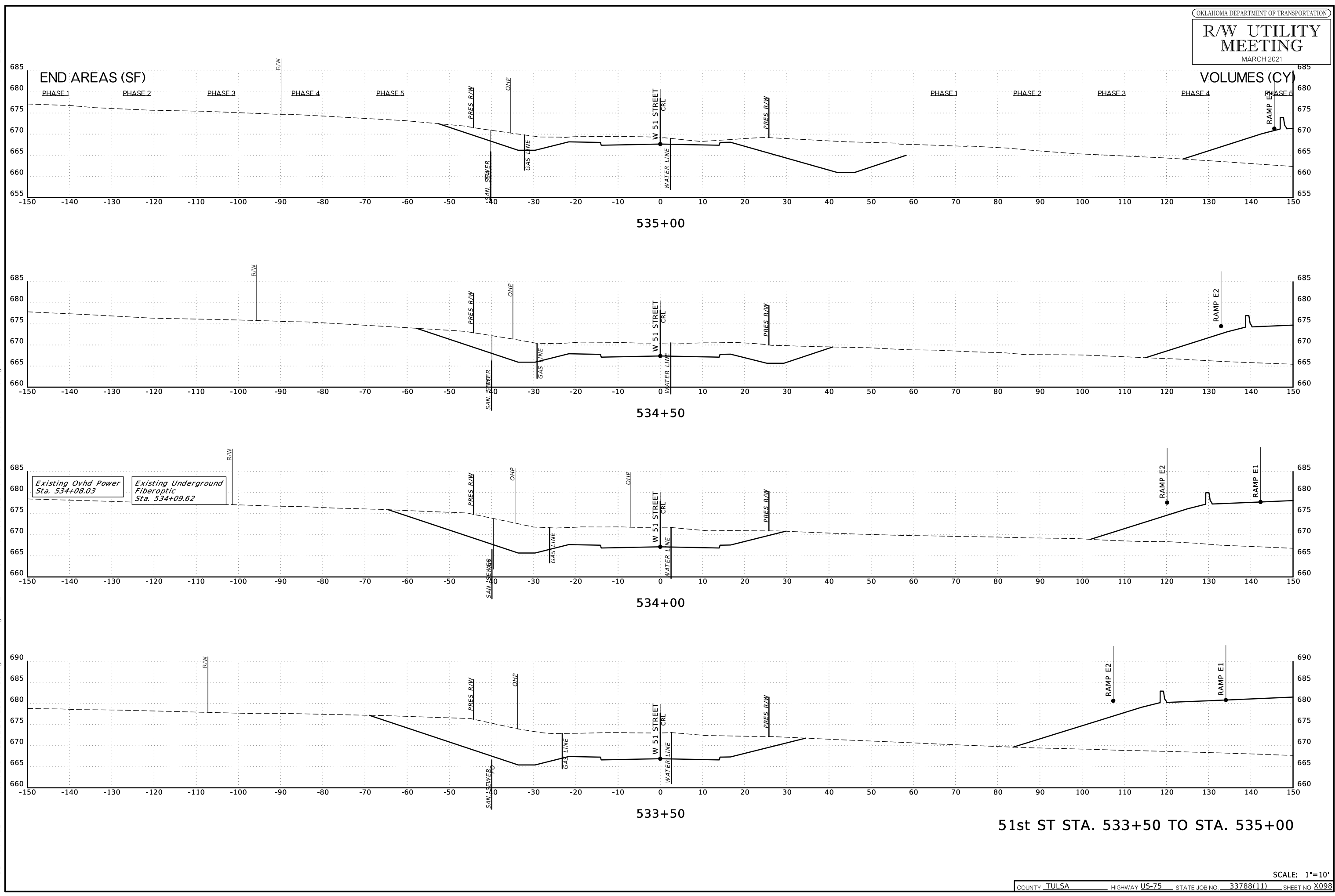

51st ST STA. 533+50 TO STA. 535+00

SCALE: 1"=10'

END AREAS (SF)

VOLUMES (CY)

PHASE 1

PHASE 2

PHASE 3

PHASE 4

PHASE 5

PHASE 1

PHASE 2

PHASE 3

PHASE 4

PHASE 5

3/4/2021

P:\FDB\1650-TUL\CIV\400315_000T_EC2123A_US75_Design-Working\CIV\MicroStation\3378811-WP5\3378811-CrossSections.dgn

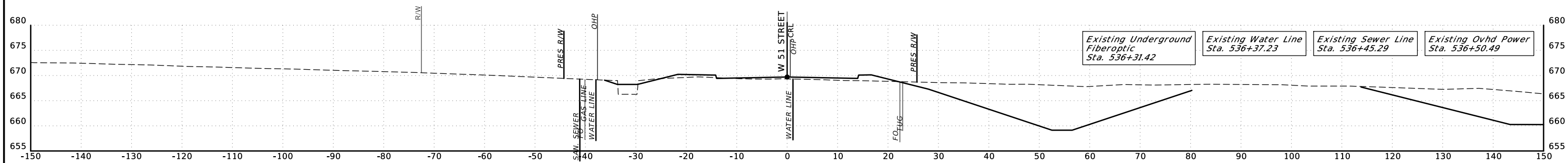

536+50

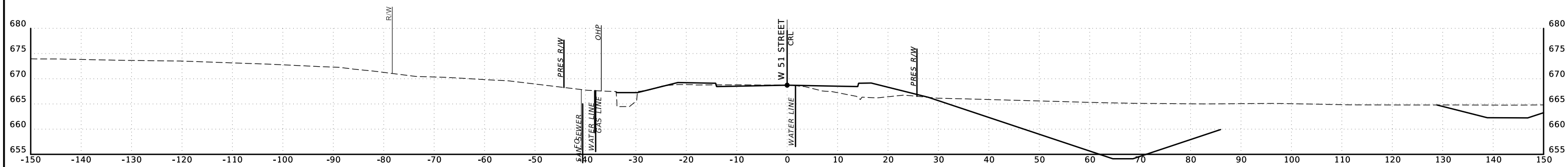

536+00

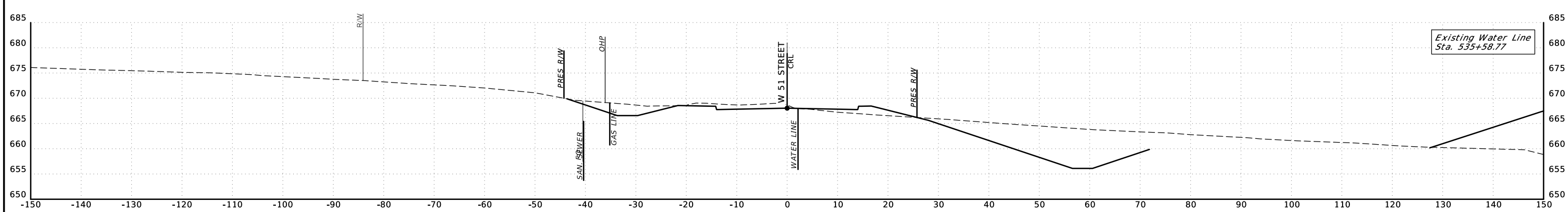

535+50

51st ST STA. 535+50 TO STA. 536+50

SCALE: 1"=10'

R/W UTILITY MEETING

MARCH 2021

END AREAS (SF)

VOLUMES (CY)

PHASE 1 PHASE 2 PHASE 3 PHASE 4 PHASE 5 PHASE 1 PHASE 2 PHASE 3 PHASE 4 PHASE 5

3/4/2021

P:\FDB\1650-TUL\CIV\400315_000T_EC2123A_US75_Design-Working\CIV\MicroStation\3378811-WP5\3378811-CrossSections.dgn

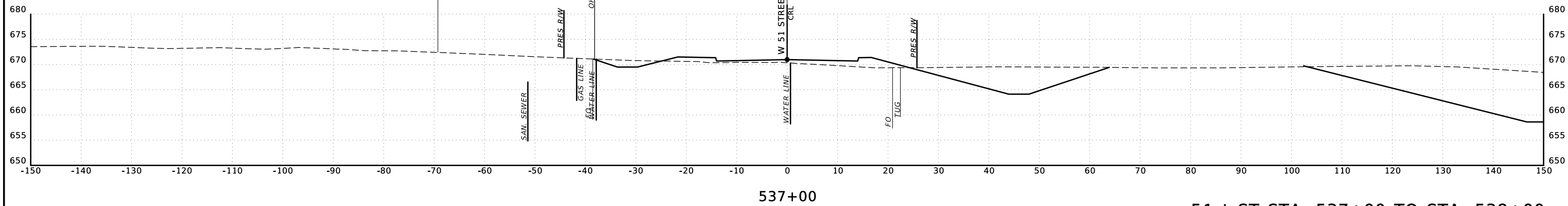
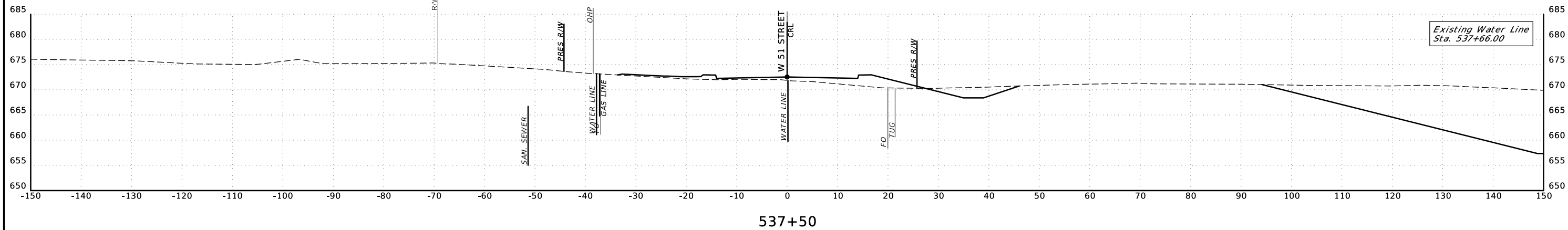
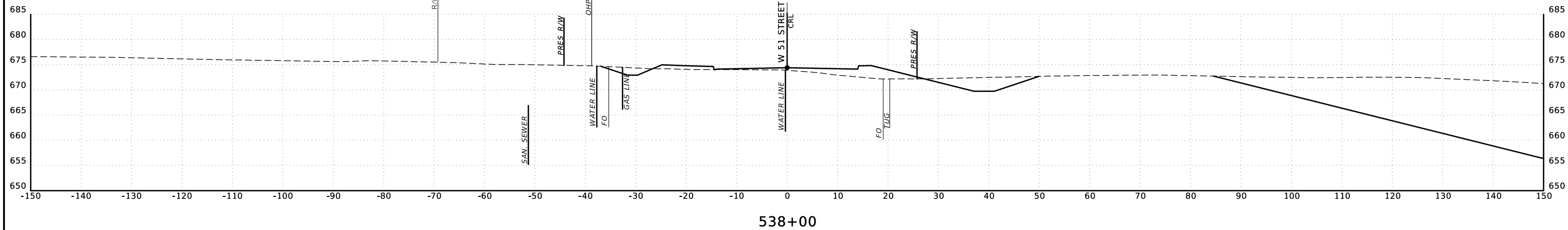

51st ST STA. 537+00 TO STA. 538+00

SCALE: 1"=10'

3/4/2021

END AREAS (SF)

VOLUMES (CY)

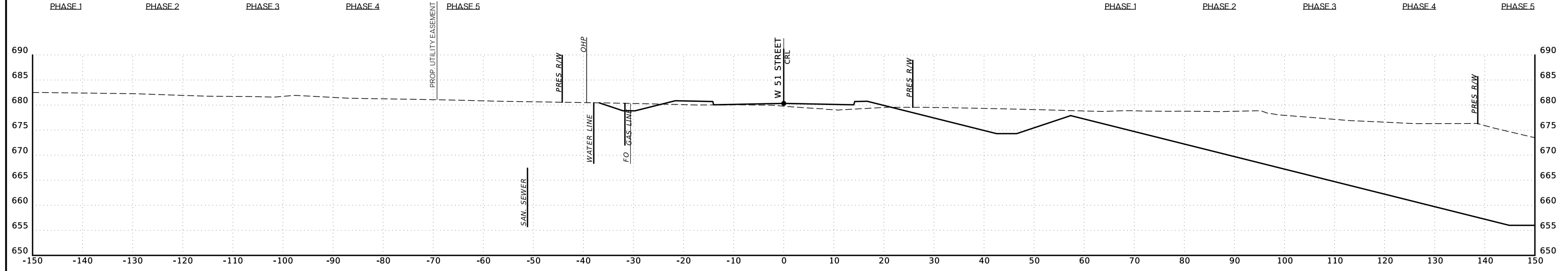

539+50

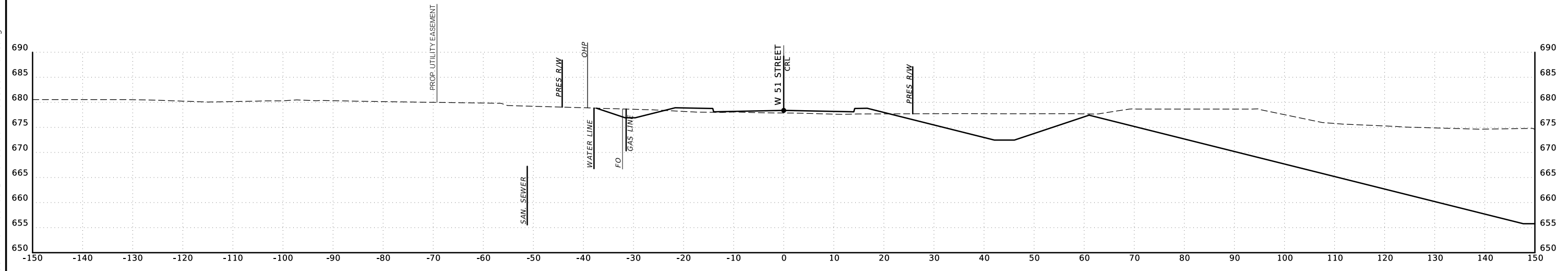

539+00

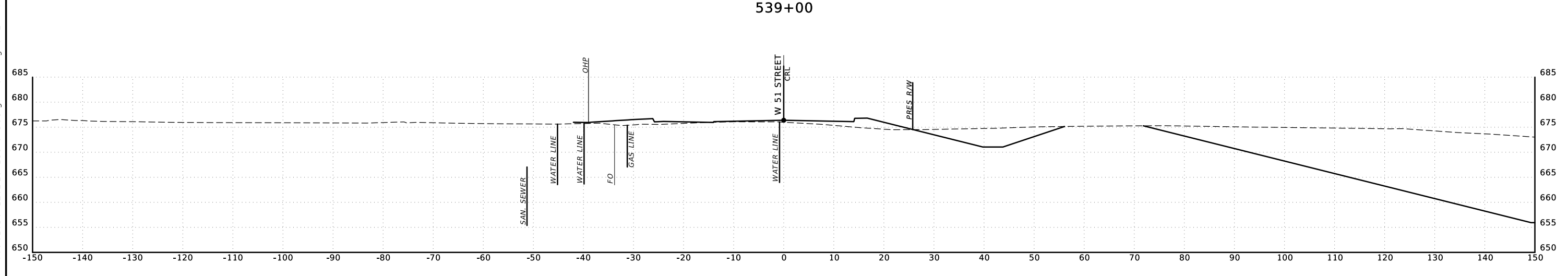

538+50

51st ST STA. 538+50 TO STA. 539+50

P:\FDB\1650-TUL\CIV\400315_000T_EC2123A_US75_Design-Working\CIV\MicroStation\3378811-WP5\3378811-CrossSections.dgn

SCALE: 1"=10'

3/4/2021

P:\FDB\1650-TUL\CIV\1400315_000T_EC2123A_US75_Design-Working\CIV\MicroStation\3378811-WP5\3378811-CrossSections.dgn

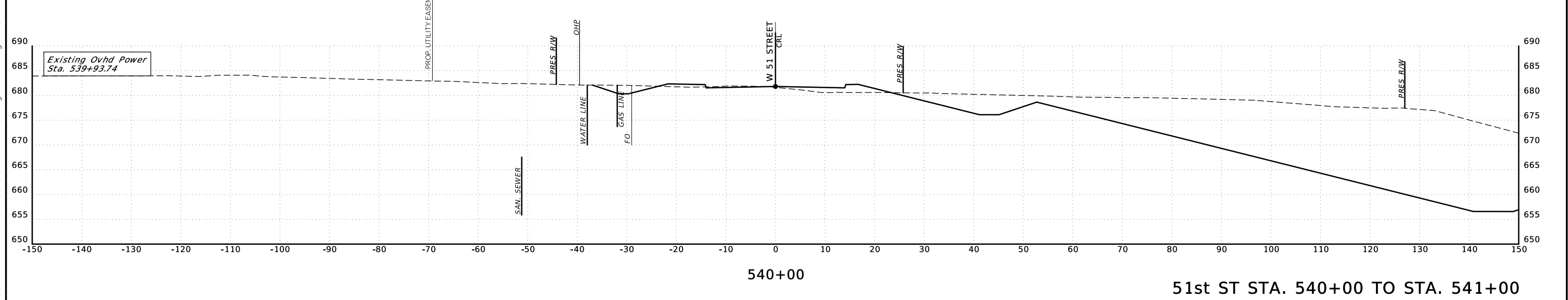
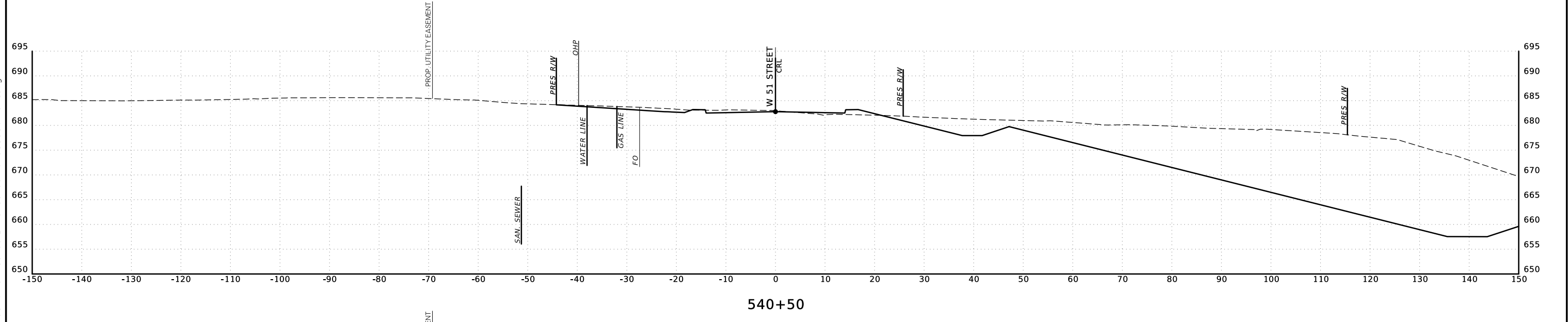
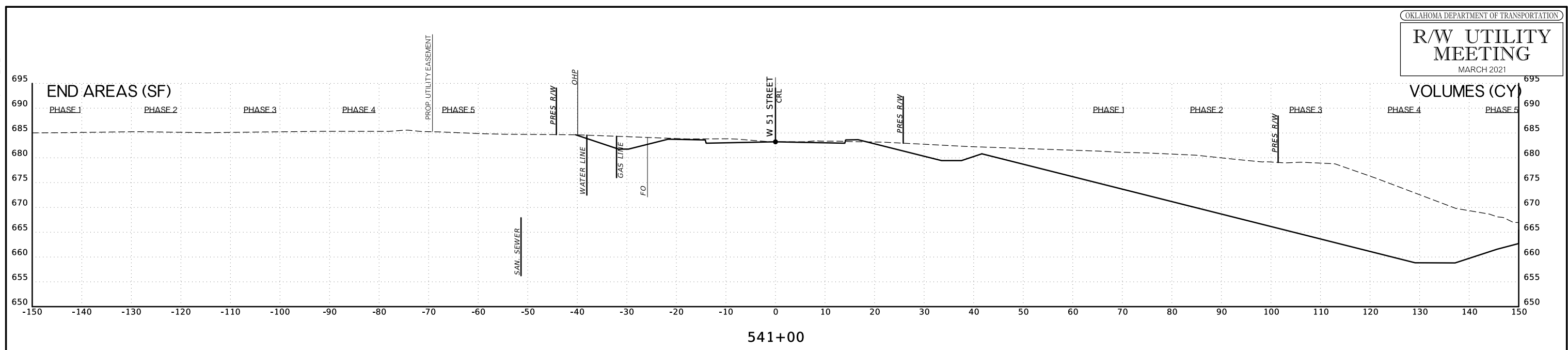

51st ST STA. 540+00 TO STA. 541+00

SCALE: 1"=10'

R/W UTILITY MEETING

MARCH 2021

3/4/2021

END AREAS (SF)

VOLUMES (CY)

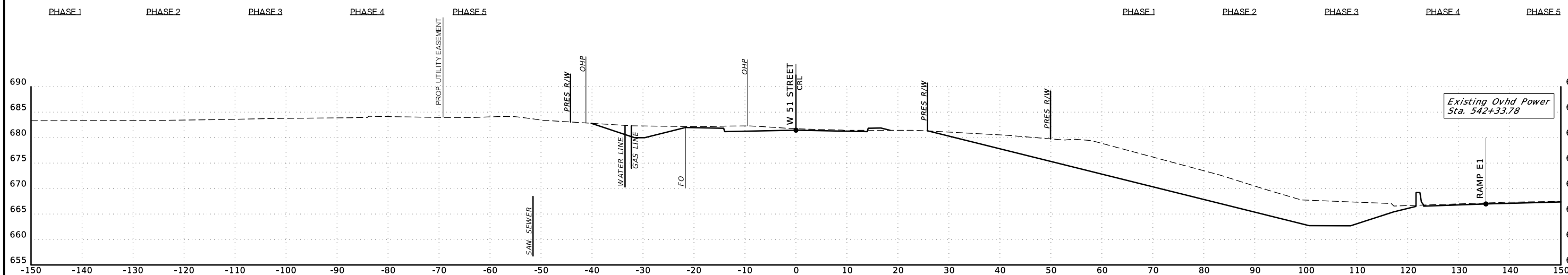

542+50

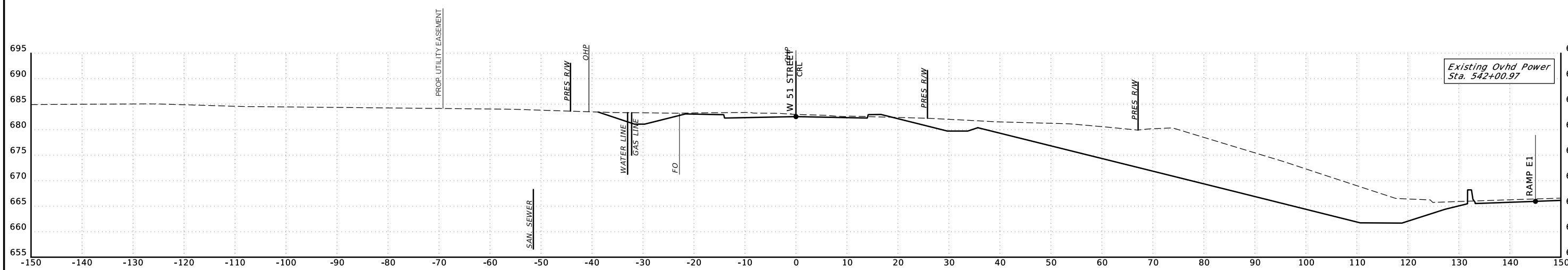

542+00

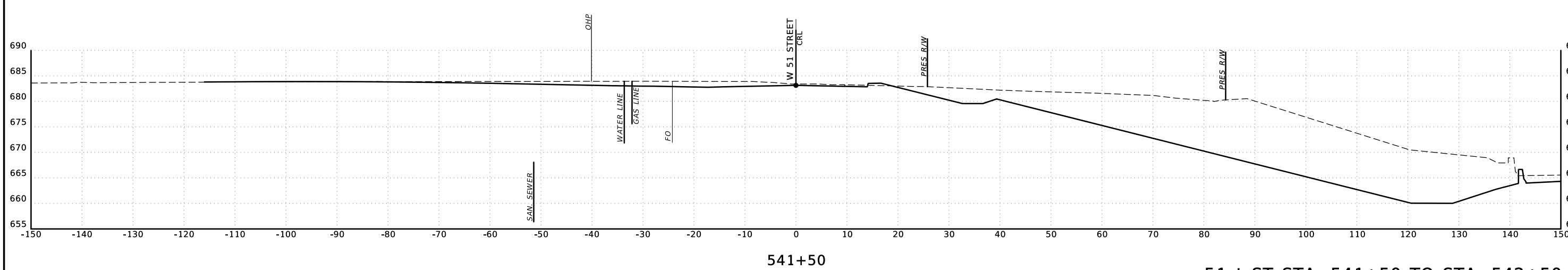

541+50

51st ST STA. 541+50 TO STA. 542+50

P:\FDB\1650-TUL\CIV\400315_000T_EC2123A_US75_Design-Working\CIV\MicroStation\3378811-WP5\3378811-CrossSections.dgn

SCALE: 1"=10'

3/4/2021

END AREAS (SF)

VOLUMES (CY)

PHASE 1

PHASE 2

PHASE 3

PHASE 4

PHASE 5

PHASE 1

PHASE 2

PHASE 3

PHASE 4

PHASE 5

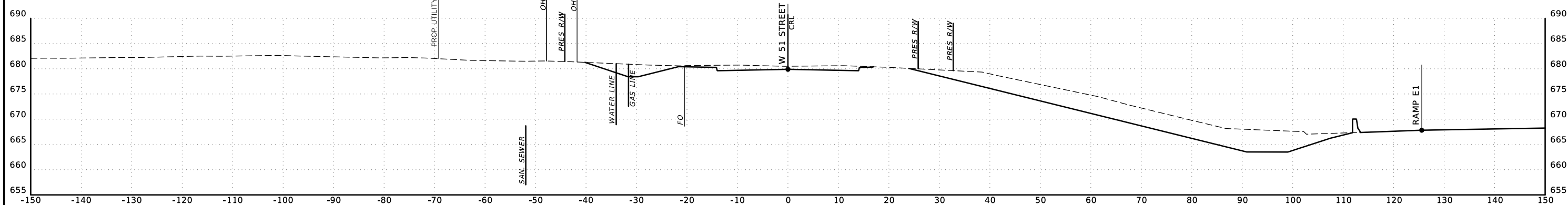
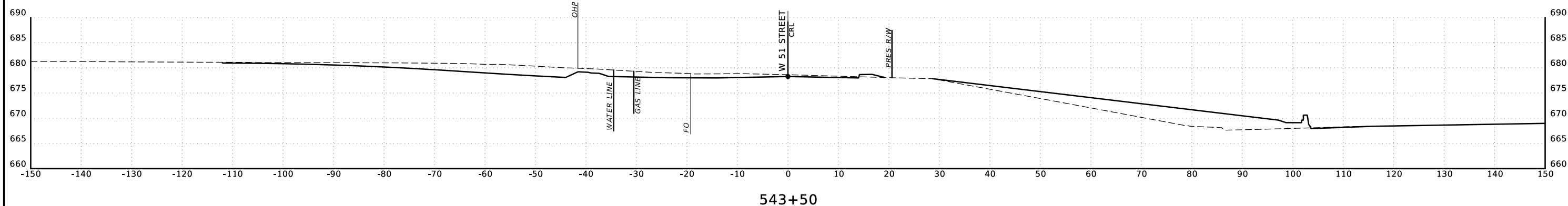
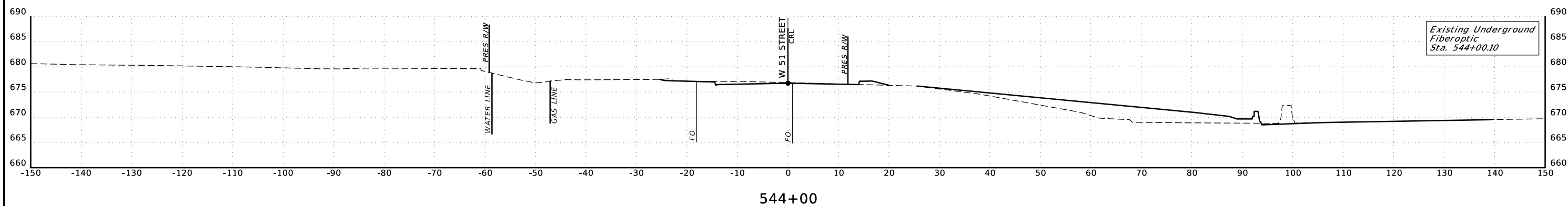

51st ST STA. 543+00 TO STA. 544+00

P:\FDB\1650-TUL\CIV\400315_000T_EC2123A_US75_Design-Working\CIV\MicroStation\3378811-WP5\3378811-CrossSections.dgn

3/4/2021

END AREAS (SF)

VOLUMES (CY)

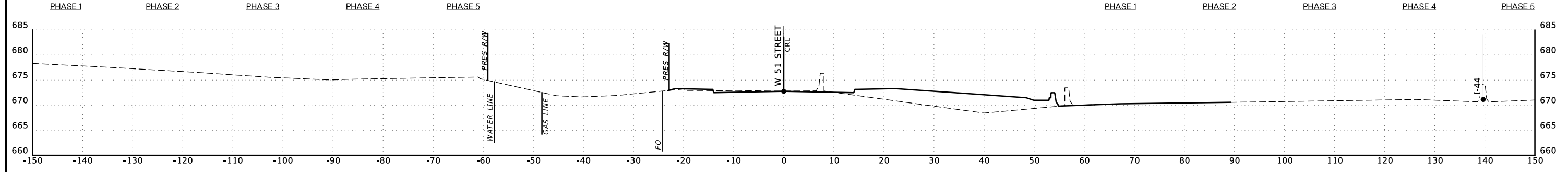

546+00

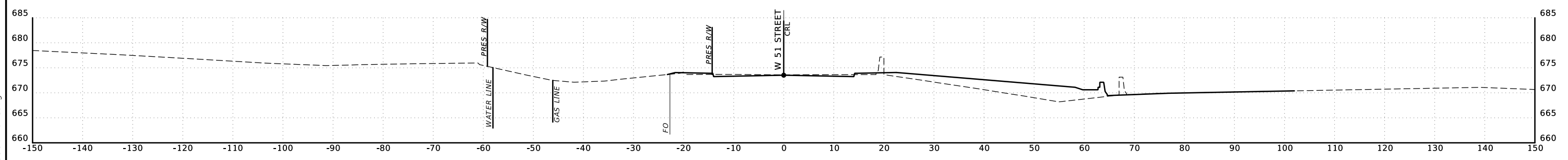

545+50

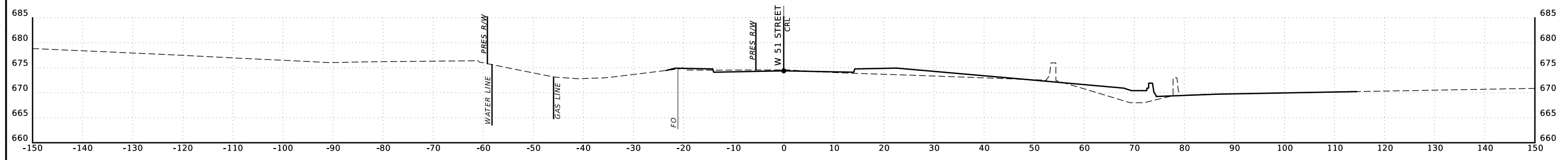

545+00

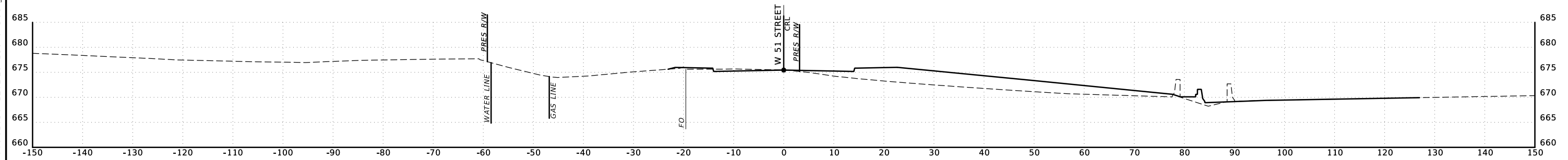

544+50

51st ST STA. 544+50 TO STA. 546+00

P:\FDB\1650-TUL\CIV\1400315_000T_EC2123A_US75\Design-Working\CIV\MicroStation\3378811-WP5\3378811-CrossSections.dgn

SCALE: 1"=10'

3/4/2021

END AREAS (SF)

VOLUMES (CY)

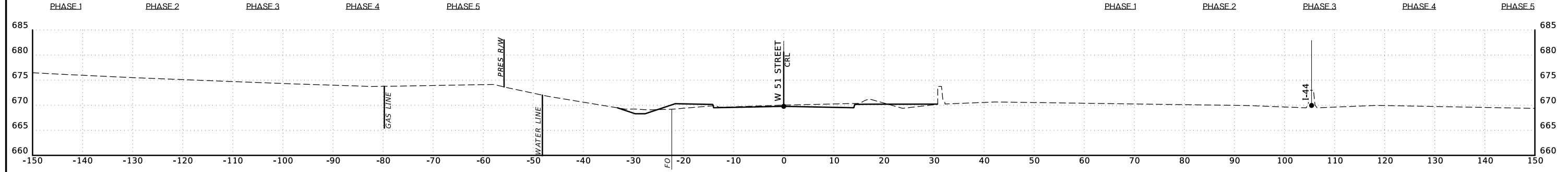

548+00

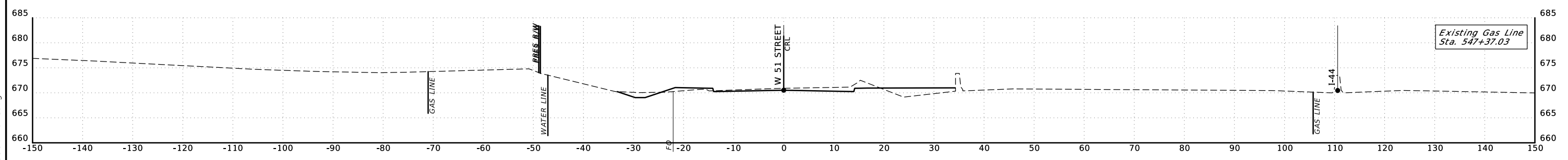

547+50

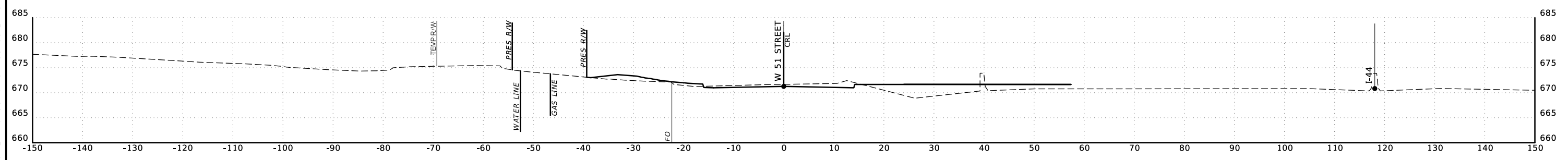

547+00

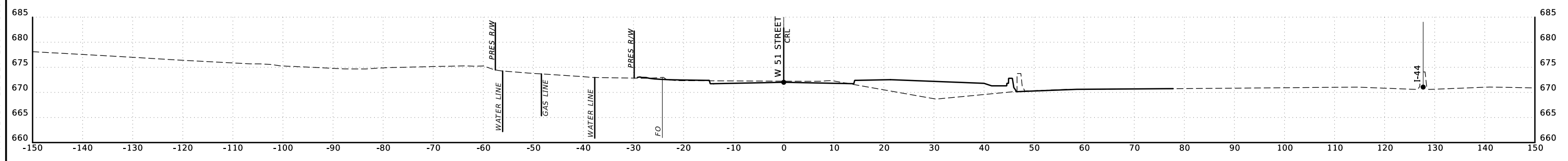

546+50

51st ST STA. 546+50 TO STA. 548+00

P:\FDB\1650-TUL\CIV\400315_000T_EC2123A_US75\Design-Working\CIV\MicroStation\3378811-WP5\3378811-CrossSections.dgn

SCALE: 1"=10'

3/4/2021

P:\FDB\1650-TUL\CIV\400315_000T_EC2123A_US75\Design-Working\CIV\MicroStation\33788II-WP5\33788II-CrossSections.dgn

END AREAS (SF)

VOLUMES (CY)

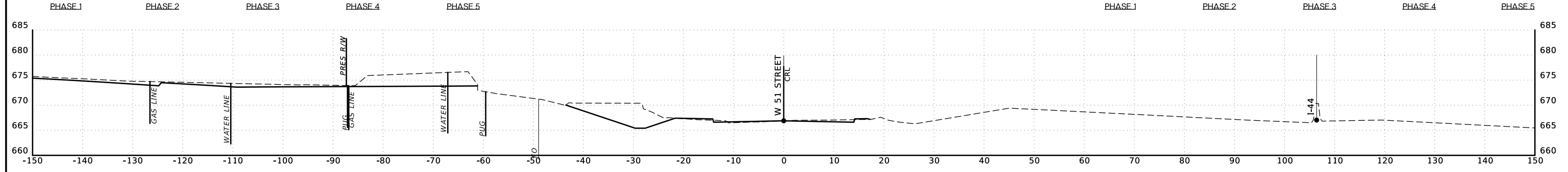

550+00

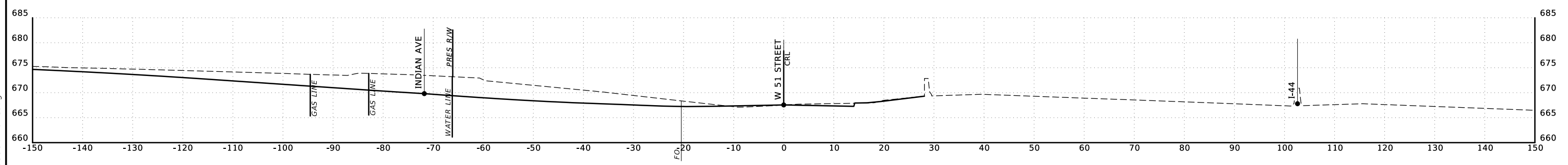

549+50

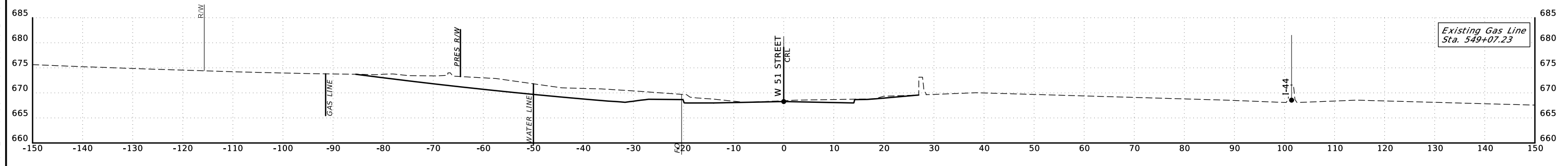

549+00

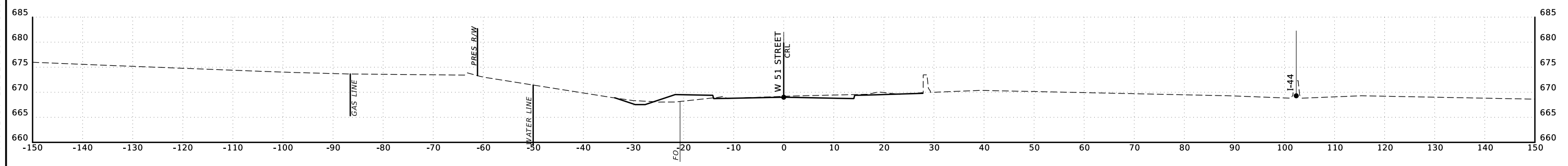

548+50

51st ST STA. 548+50 TO STA. 550+00

SCALE: 1"=10'

3/4/2021

END AREAS (SF)

VOLUMES (CY)

STA. 552+01.56 - END 51st ST

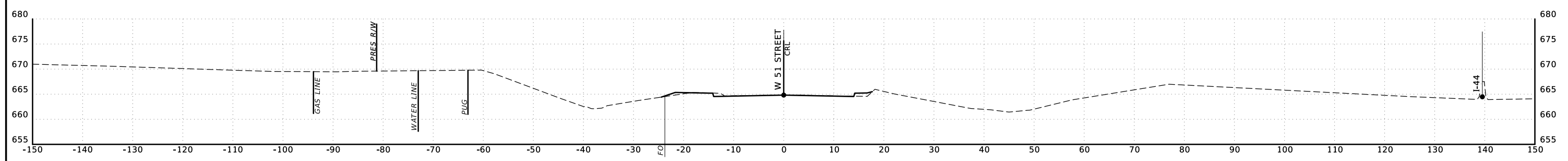

552+00

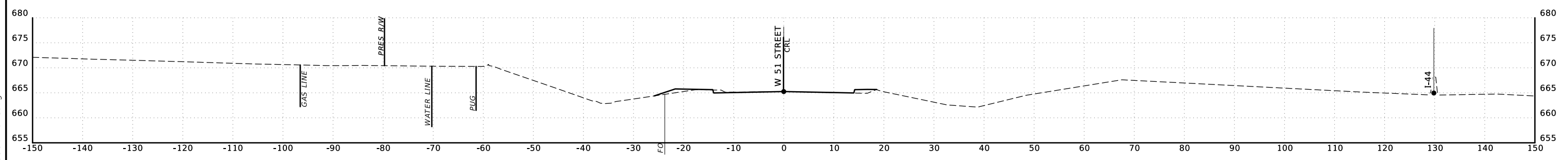

551+50

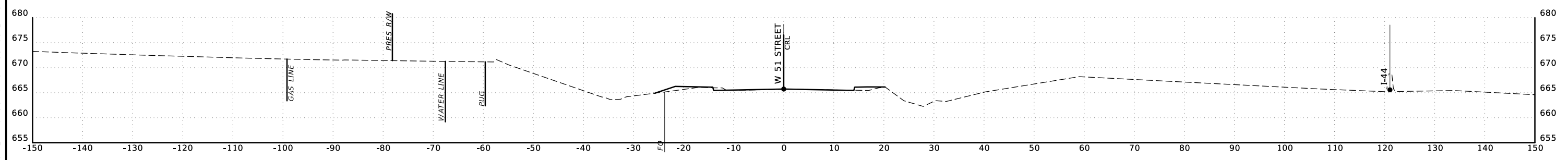

551+00

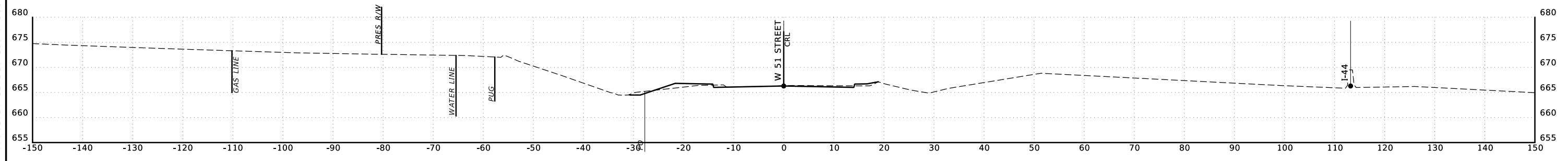

550+50

51st ST STA. 550+50 TO STA. 552+00

P:\FDB\1650-TUL\CIV\400315_000T_EC2123A_US75\Design-Working\CIV\MicroStation\3378811-WP5\3378811-CrossSections.dgn

SCALE: 1"=10'

3/4/2021

END AREAS (SF)

VOLUMES (CY)

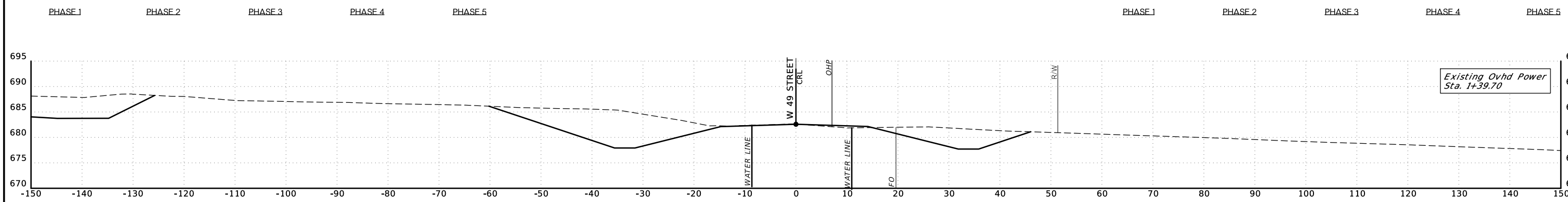

1+50
STA. 1+25.00 - BEGIN 49th ST

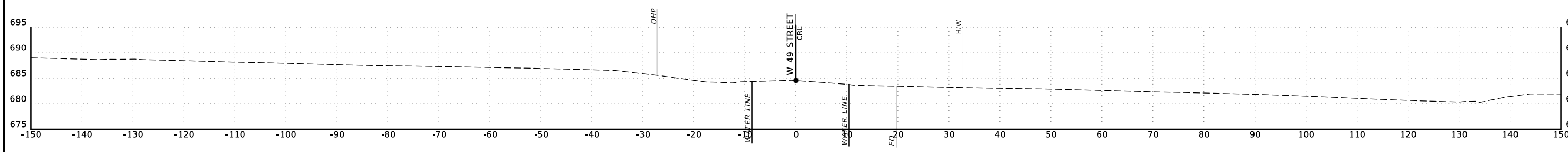

1+00

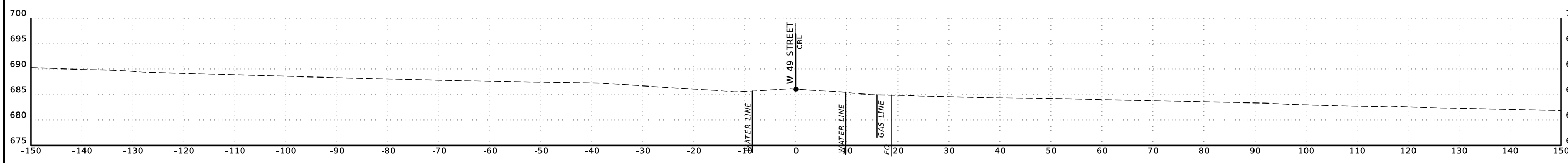

0+50

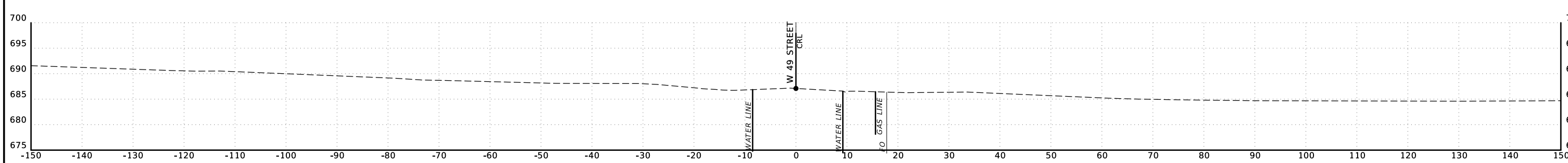

0+00

49th ST STA. 0+00 TO STA. 1+50

P:\FDB\1650-TUL\CIV\1400315_000T_EC2123A_US75\Design-Working\CIV\MicroStation\3378811-WP5\3378811-CrossSections.dgn

3/4/2021

P:\FDB\1650-TUL\CIV\1400315_000T_EC2123A_US75_Design-Working\CIV\MicroStation\3378811-WP5\3378811-CrossSections.dgn

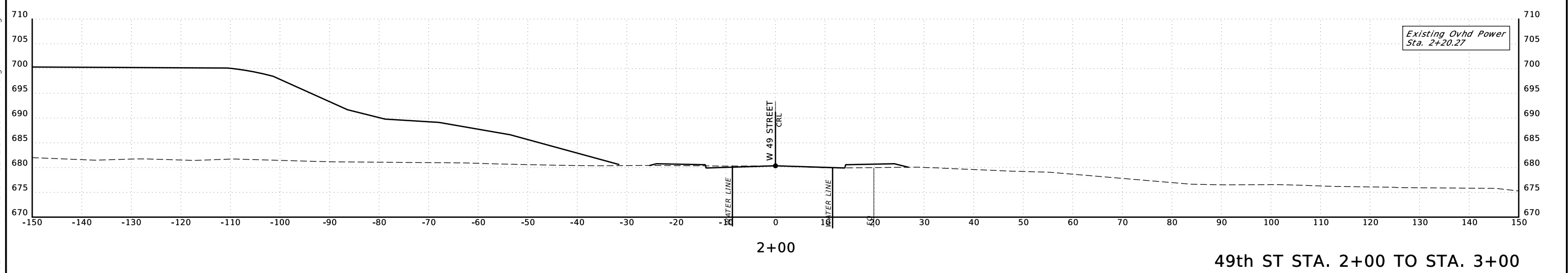
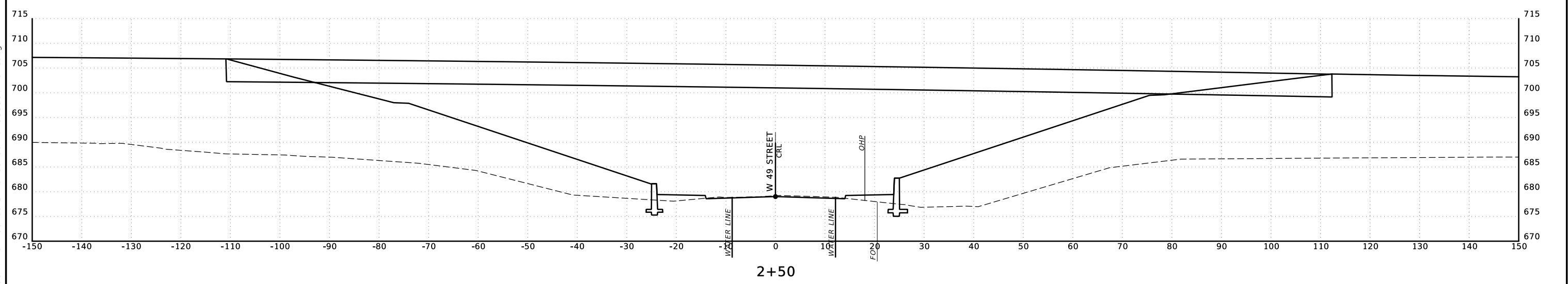
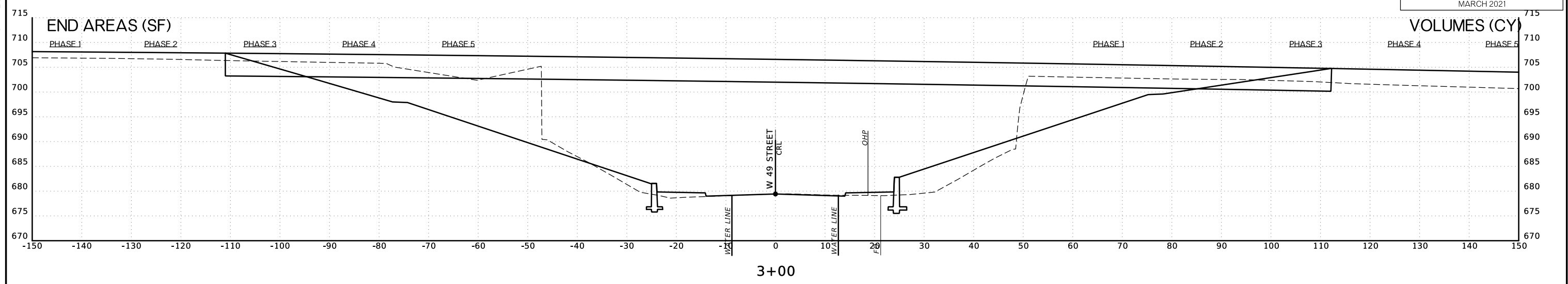

49th ST STA. 2+00 TO STA. 3+00

SCALE: 1"=10'

3/4/2021

P:\FDB\1650-TUL\CIV\1400315_000T_EC2123A_US75_Design-Working\CIV\MicroStation\33788II-CrossSections.dgn

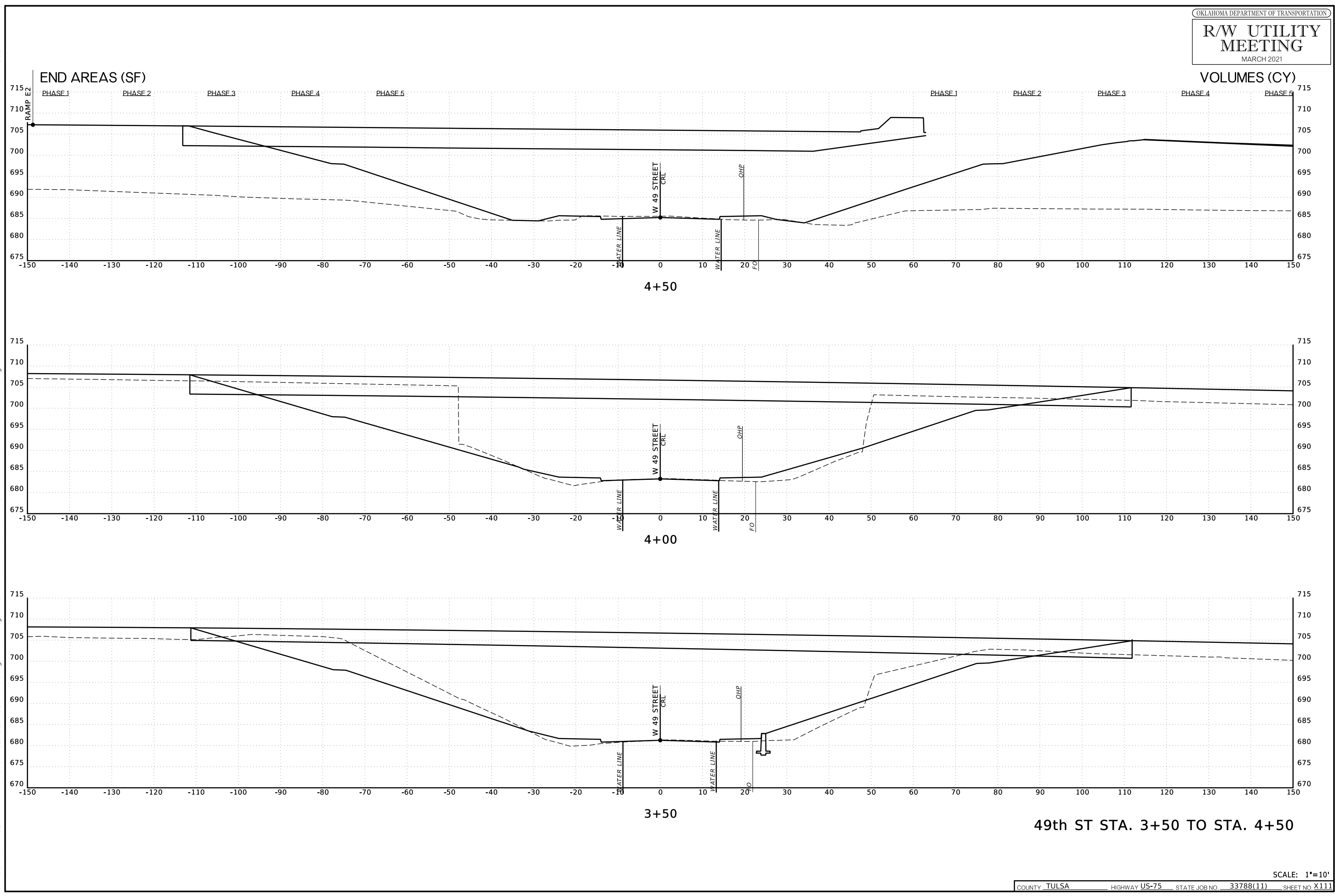

END AREAS (SF)

VOLUMES (CY)

PHASE 1 PHASE 2 PHASE 3 PHASE 4 PHASE 5 PHASE 1 PHASE 2 PHASE 3 PHASE 4 PHASE 5

3/4/2021

P:\FDB\1650-TUL\CIV\1400315_000T_EC2123A_US75_Design-Working\CIV\MicroStation\3378811-WP5\3378811-CrossSections.dgn

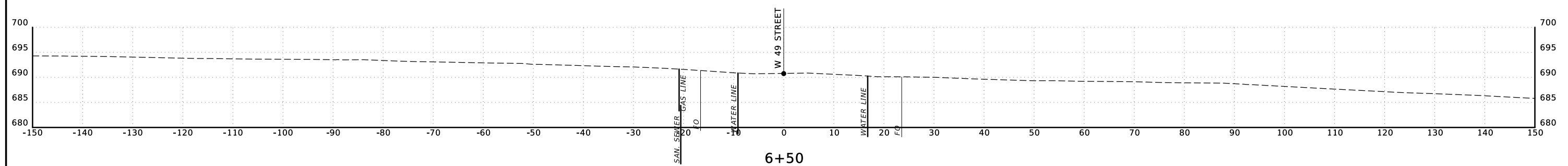

6+50

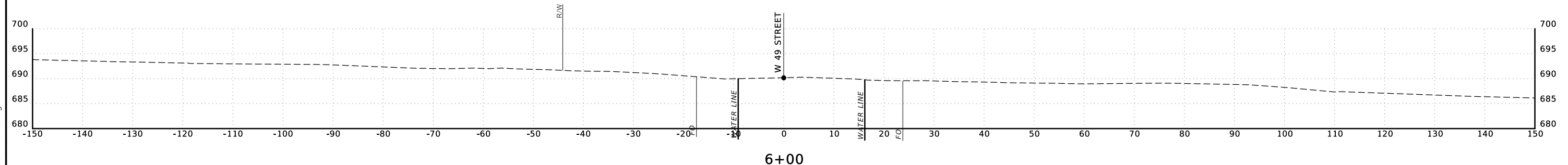

6+00

STA. 5+75.00 - END 49th ST

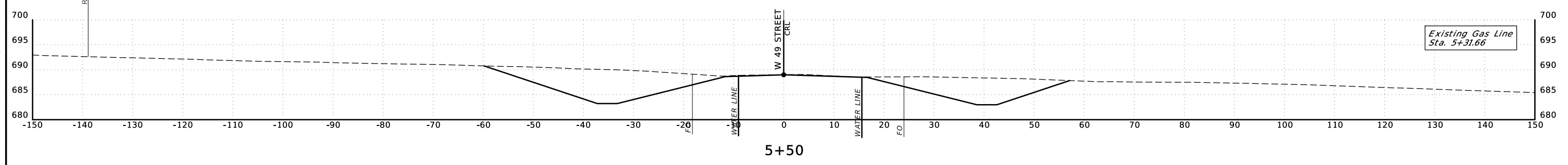

5+50

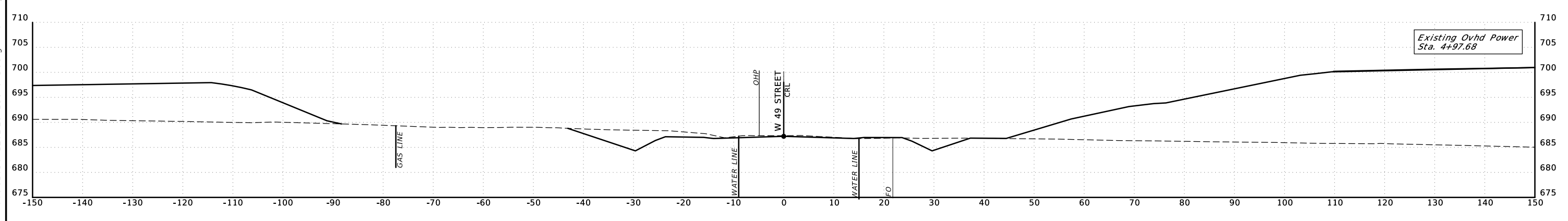

5+00

49th ST STA. 5+00 TO STA. 6+50

SCALE: 1"=10'

R/W UTILITY MEETING

MARCH 2021

3/4/2021

END AREAS (SF)

PHASE 1 PHASE 2 PHASE 3 PHASE 4 PHASE 5

VOLUMES (CY)

PHASE 1 PHASE 2 PHASE 3 PHASE 4 PHASE 5

P:\FDB\1650-TUL\CIV\1400315_000T_EC2123A_US75\Design-Working\CIV\MicroStation\3378811-WP5\3378811-CrossSections.dgn

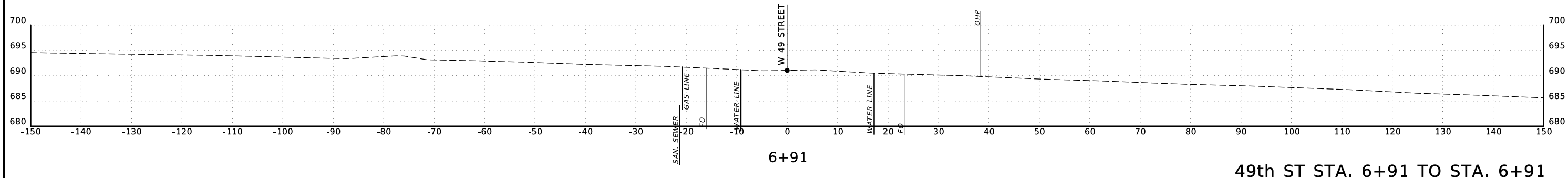

49th ST STA. 6+91 TO STA. 6+91

SCALE: 1"=10'

END AREAS (SF)

VOLUMES (CY)

PHASE 1 PHASE 2 PHASE 3 PHASE 4 PHASE 5 PHASE 1 PHASE 2 PHASE 3 PHASE 4 PHASE 5

P:\FDB\1650-TUL\CIV\1400315_000T_EC2123A_US75_Design-Working\CIV\MicroStation\3378811-WP5\3378811-CrossSections.dgn 3/4/2021

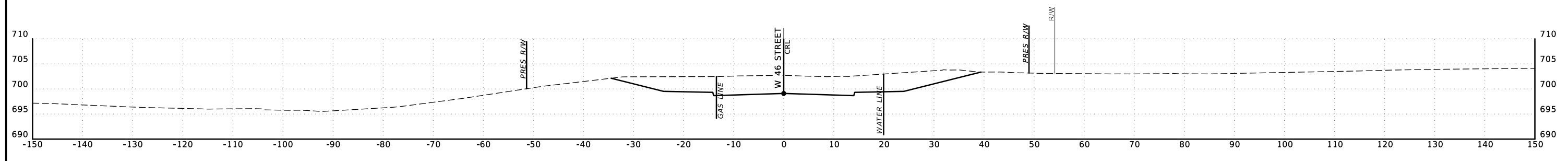

43+50

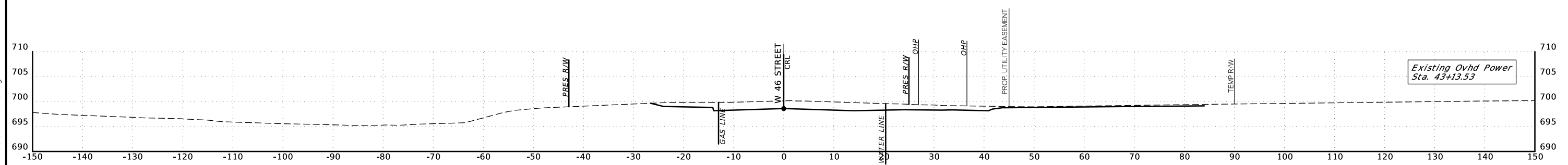

43+00

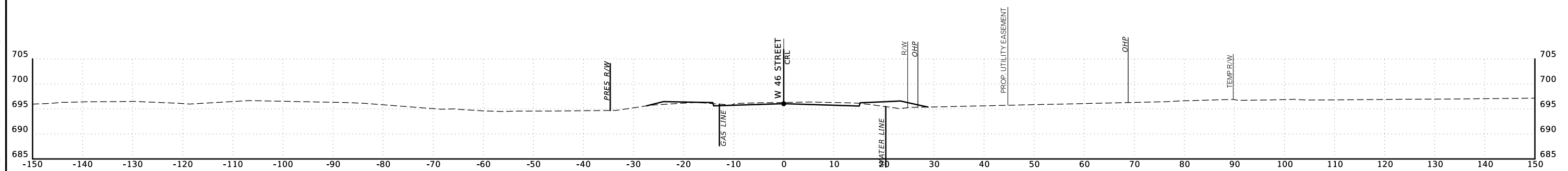

42+50

STA. 42+09.00 - BEGIN 46th ST

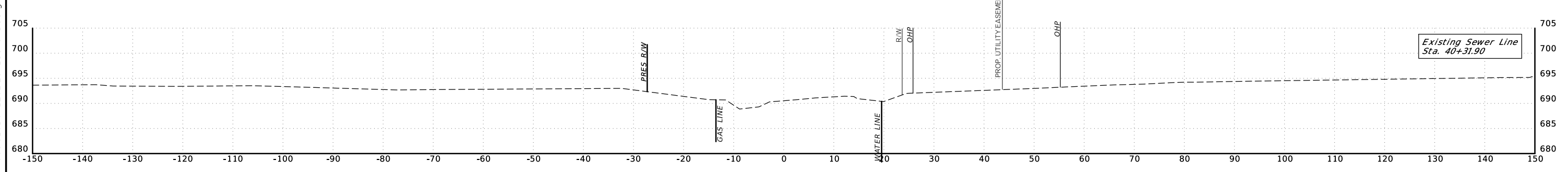

42+00

46th ST STA. 42+00 TO STA. 43+50

SCALE: 1"=10'

END AREAS (SF)

VOLUMES (CY)

PHASE 1

PHASE 2

PHASE 3

PHASE 4

PHASE 5

PHASE 1

PHASE 2

PHASE 3

PHASE 4

PHASE 5

3/4/2021

P:\FDB\1650-TUL\CIV\400315_000T_EC2123A_US75\Design-Working\CIV\MicroStation\3378811-WP5\3378811-CrossSections.dgn

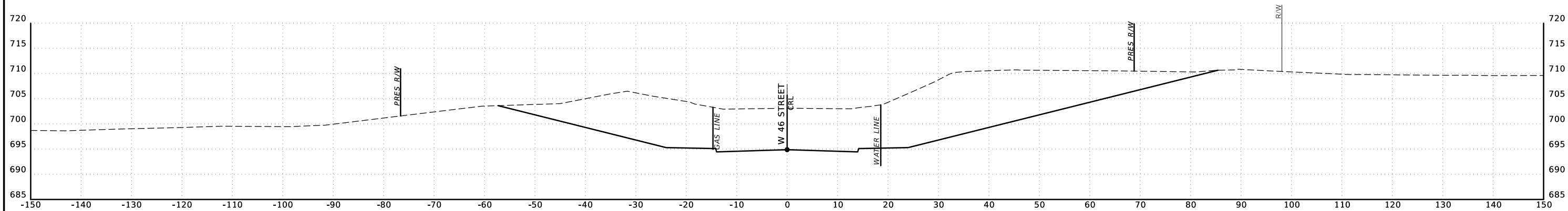

45+00

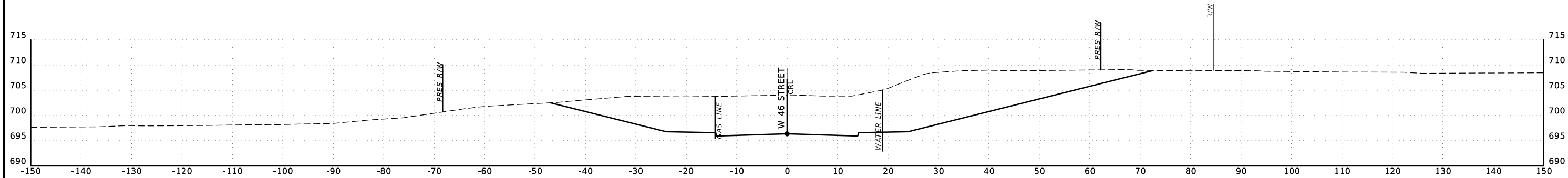

44+50

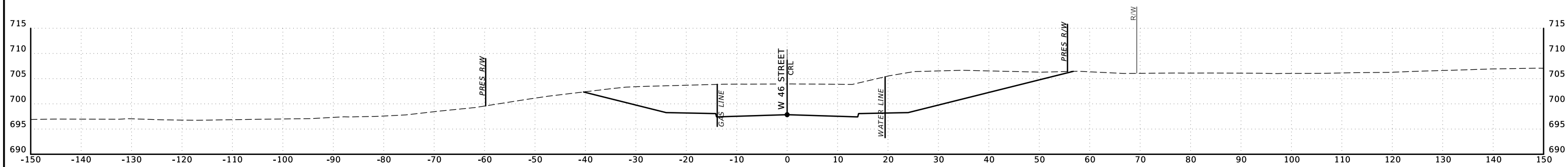

44+00

46th ST STA. 44+00 TO STA. 45+00

SCALE: 1"=10'

3/4/2021

END AREAS (SF)

VOLUMES (CY)

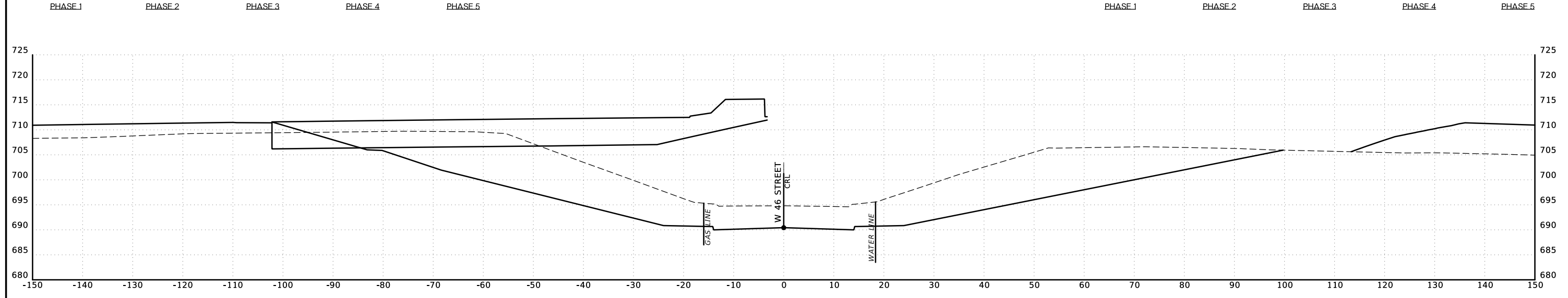

46+50

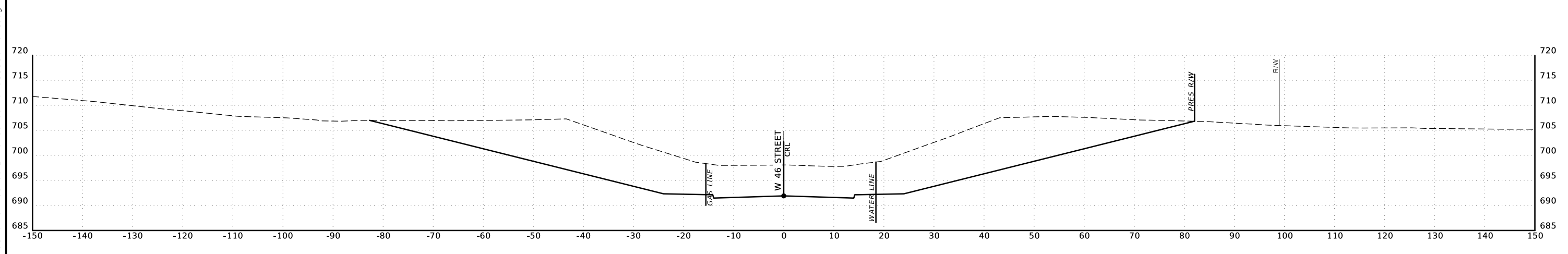

46+00

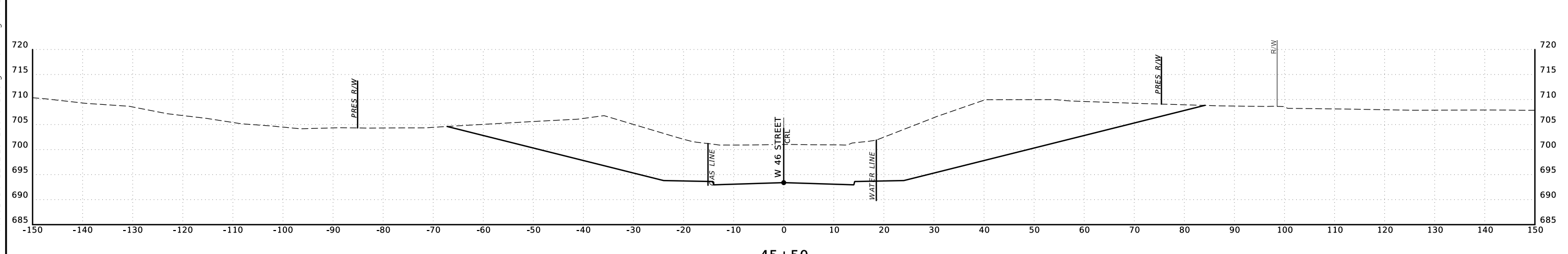

45+50

46th ST STA. 45+50 TO STA. 46+50

P:\FDB\1650-TUL\CIV\1400315_000T_EC2123A_US75_Design-Working\CIV\MicroStation\3378811-WP5\3378811-CrossSections.dgn

SCALE: 1"=10'

R/W UTILITY MEETING

MARCH 2021

END AREAS (SF)

PHASE 1 PHASE 2 PHASE 3 PHASE 4 PHASE 5

VOLUMES (CY)

PHASE 1 PHASE 2 PHASE 3 PHASE 4 PHASE 5

3/4/2021

P:\FDB\1650-TUL\CIV\400315_000T_EC2123A_US75_Design-Working\CIV\MicroStation\3378811-CrossSections.dgn

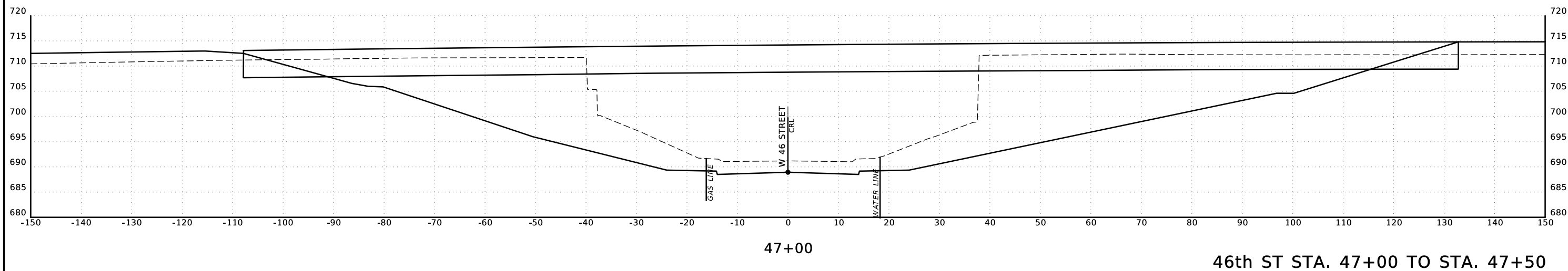
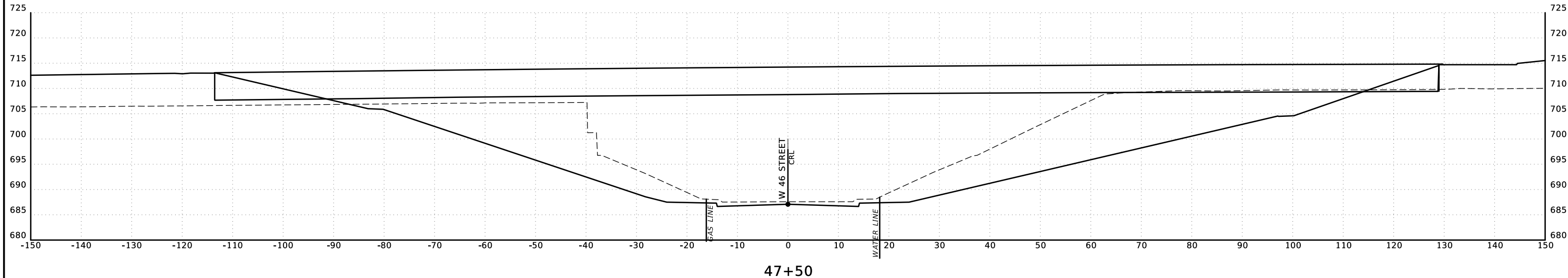

46th ST STA. 47+00 TO STA. 47+50

SCALE: 1"=10'

END AREAS (SF)

PHASE 1 PHASE 2 PHASE 3 PHASE 4 PHASE 5

VOLUMES (CY)

PHASE 1 PHASE 2 PHASE 3 PHASE 4 PHASE 5

3/4/2021

P:\FDB\1650-TUL\CIV\400315_000T_EC2123A_US75_Design-Working\CIV\MicroStation\3378811-CrossSections.dgn

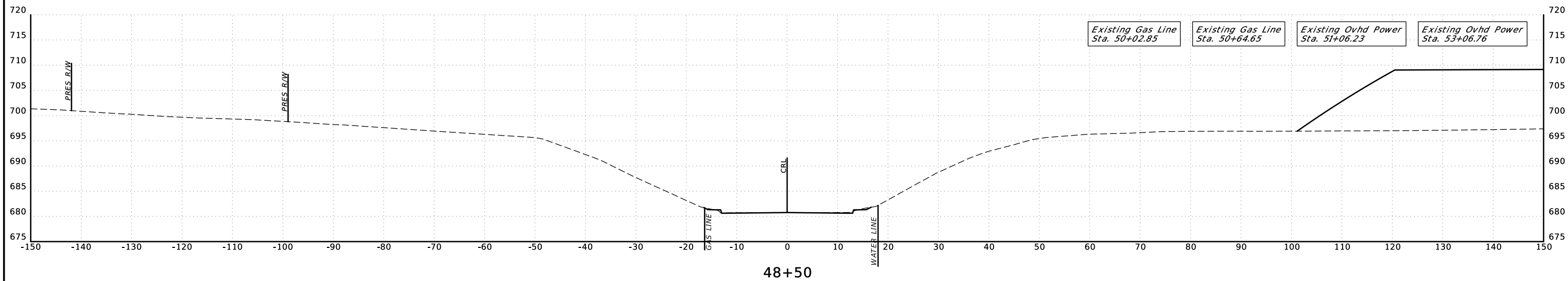

STA. 48+20.00 - END 46th ST

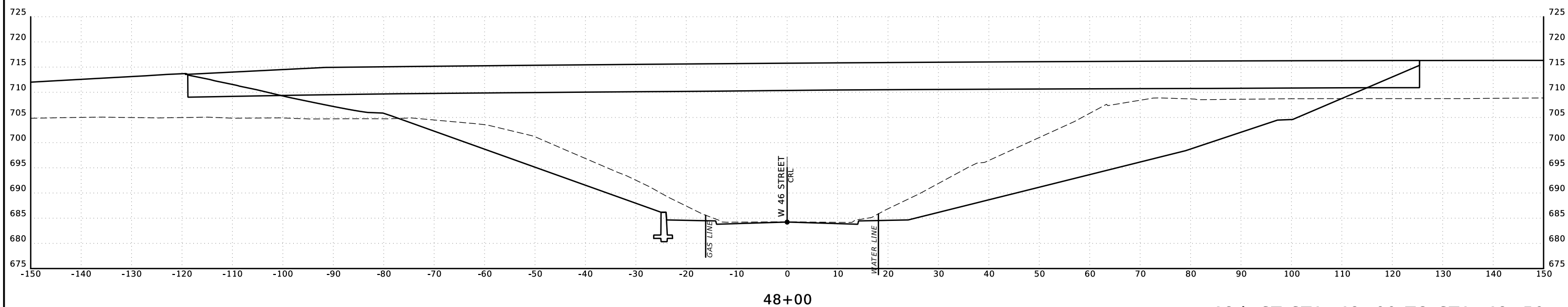

46th ST STA. 48+00 TO STA. 48+50

SCALE: 1"=10'