

**INTERSTATE 40 BRIDGE  
(EXISTING)  
OVER THE ARKANSAS RIVER  
MUSKOGEE & SEQUOYAH COUNTIES, OKLAHOMA**

**VESSEL COLLISION RISK ASSESSMENT  
2022 UPDATE**



For

**STATE OF OKLAHOMA  
DEPARTMENT OF TRANSPORTATION**

By

**Modjeski and Masters, Inc.  
as Subconsultant to EST, Inc.**

## I-40 BRIDGE (EXISTING)

### TABLE OF CONTENTS

|   |           |
|---|-----------|
| <b>1. INTRODUCTION.....</b>   | <b>3</b>  |
| 1.1 Authority .....   | 3         |
| 1.2 Scope of Work .....   | 3         |
| 1.3 Approach.....   | 3         |
| <b>2. BRIDGE CHARACTERISTICS.....</b>   | <b>3</b>  |
| 2.1 Location, Type, Size and Geometry .....   | 3         |
| 2.2 Design Criteria.....  | 6         |
| 2.3 Piers, Footing Depth, and Soil Information.....                                 | 6         |
| 2.4 Existing Protection.....  | 9         |
| 2.5 Upstream and Downstream Locks and Dams.....                                     | 10        |
| <b>3. RISK FACTORS AND HISTORICAL ACCIDENT DATA.....</b>                            | <b>11</b> |
| 3.1 General.....  | 11        |
| 3.2 Update of Historical Marine Incidents on the Arkansas and Verdigris Rivers..... | 12        |
| 3.3 Marine Accidents at the Bridge Site .....                                       | 15        |
| 3.4 Marine Accidents due to Barge Breakaways.....                                   | 16        |
| <b>4. WATERWAY CHARACTERISTICS AND ENVIRONMENTAL<br/>CONDITIONS.....</b>            | <b>18</b> |
| 4.1 General.....  | 18        |
| 4.2 Channel Layout and Geometry .....   | 18        |
| 4.3 Water Depth and Fluctuations .....  | 19        |
| 4.4 Current Direction and Velocities .....  | 21        |
| 4.5 Conclusions.....  | 22        |
| <b>5. UPDATE OF VESSEL TRAFFIC CHARACTERISTICS .....</b>                            | <b>23</b> |
| 5.1 Sources of Traffic Data.....  | 23        |
| 5.2 Vessel Types .....  | 23        |
| 5.3 Historical Traffic Data .....   | 26        |

|   |           |
|---|-----------|
| 5.4 Present Traffic Data .....  | 37        |
| 5.5 Projection of Future Traffic .....                                | 41        |
| 5.6 Evaluation Vessel Groups .....                                    | 41        |
| 5.7 Navigation Conditions and Regulations .....                       | 44        |
| <b>6. MARINE TERMINALS, WHARVES AND DOCKS .....</b>                   | <b>46</b> |
| 6.1 General .....   | 46        |
| 6.2 Facilities Near the I-40 Bridge Crossing .....                    | 46        |
| <b>7. VESSEL COLLISION ANALYSIS .....</b>                             | <b>49</b> |
| 7.1 Methodology .....   | 49        |
| 7.2 Evaluation Vessels and Vessel Access to Bridge Piers .....        | 49        |
| 7.3 Probability of Aberrancy .....                                    | 50        |
| 7.4 Geometric Probability .....                                       | 54        |
| 7.5 Vessel Impact Speed and Collision Force .....                     | 54        |
| 7.6 Substructure Capacities .....                                     | 55        |
| 7.7 Design Water Elevation .....                                      | 56        |
| 7.8 Probability of Collapse .....                                     | 56        |
| 7.9 Annual Frequencies of Collapse .....                              | 57        |
| 7.10 Bridge Classification Criteria .....                             | 57        |
| 7.11 Analysis Results for the Existing Bridge – Previous Study .....  | 59        |
| 7.12 Analysis Results for the Existing Bridge - Current Study .....   | 60        |
| 7.13 Substructure Capacities Recommendations for the New Bridge ..... | 62        |
| <b>8. PREVENTION AND PROTECTION MEASURES .....</b>                    | <b>67</b> |
| 8.1 General .....   | 67        |
| 8.2 Prevention Measures .....   | 67        |
| 8.3 Physical Protection .....   | 68        |
| 8.4 Motorist Warning Systems .....                                    | 68        |
| <b>9. SUMMARY OF FINDINGS AND CONCLUSIONS .....</b>                   | <b>70</b> |
| <b>10. REFERENCES .....</b>   | <b>72</b> |

## **1. INTRODUCTION**

### **1.1 Authority**

This vessel collision study is part of the Oklahoma Department of Transportation (ODOT) State Job No. 34334(04) whose primary purpose is to replace the I-40 Bridge over Arkansas River, Muskogee and Sequoyah Counties. It was authorized by Contract Identification No. 2324 Preliminary Engineering Project No. NHPPI-4000(153)EC Job Piece No. 34334(07) Muskogee County between ODOT and EST, Inc. dated 10/05/2021.

### **1.2 Scope of Work**

The required scope of work for the vessel collision study includes collection and review of existing bridge and waterway information, vessel traffic characteristics, risk factors and historical accident data, and vulnerability analysis followed by recommendations for protection and collision prevention. The vessel collision study is prepared for the proposed bridge based on the requirements of AASHTO LRFD Bridge Design Specifications, 9th Edition.

### **1.3 Approach**

The approach used in this vessel collision study included several phases. The first phase focused on updating the 2005 vessel collision study performed by Modjeski and Masters, Inc. by accounting for changes in the vessel traffic characteristics, waterway and navigation conditions, frequency and nature of vessel related accidents and changes in the AASHTO specifications. The second phase included the development of an updated risk model for the I-40 Bridge crossing, and the third phase involves the application of the model to the proposed bridge design.

The collection of vessel traffic, waterway, navigation, and vessel related incidents used various sources of information including federal and state agencies, organizations, individuals, and several publications including USACE and NTSB reports. Data on the existing bridge characteristics was obtained from the previous study.

## **2. BRIDGE CHARACTERISTICS**

### **2.1 Location, Type, Size and Geometry**

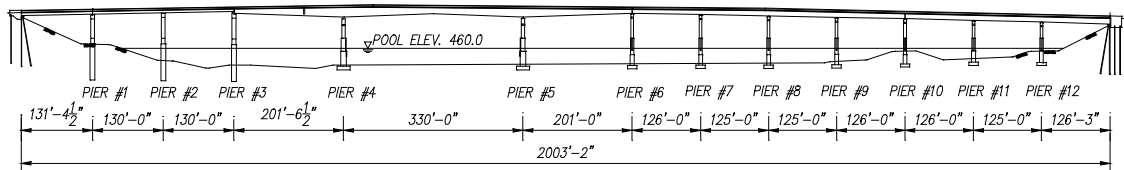
The Interstate 40 Bridge is located in Muskogee and Sequoyah Counties, near Webbers Falls, Oklahoma, as shown in Figure 2.1-1. It crosses the McClellan-Kerr Arkansas River Navigation System (MKARNS), at river mile 360.3, between the Webbers Falls Lock & Dam (upstream) and the Robert S. Kerr Lock & Dam (downstream), within the Kerr Lake Conservation Pool. The navigation distance from the bridge to the Webbers Falls Lock & Dam is 6.3 river miles, and the distance to the

Robert S. Kerr Lock & Dam is 24.1 river miles. The SH-100 Bridge is located 2.8 miles upstream from the I-40 Bridge.

The bridge is 2,003.16 feet long and consists of 10 composite steel plate girder spans and 3 prestressed concrete bulb tee girder spans on concrete piers (see Figure 2.1-2). The main span is 330 feet long over the navigation channel. The construction of the bridge was completed in 1968.

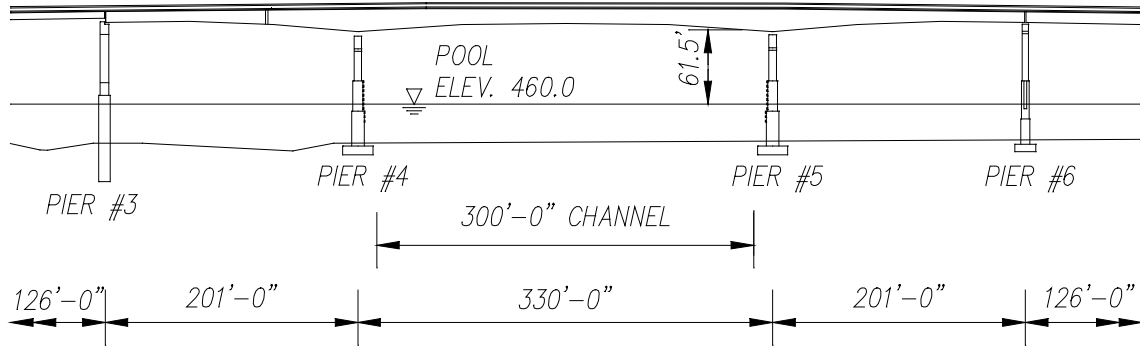


**Figure 2.1-1: Bridge Location**



**Figure 2.1-2: Bridge Elevation**

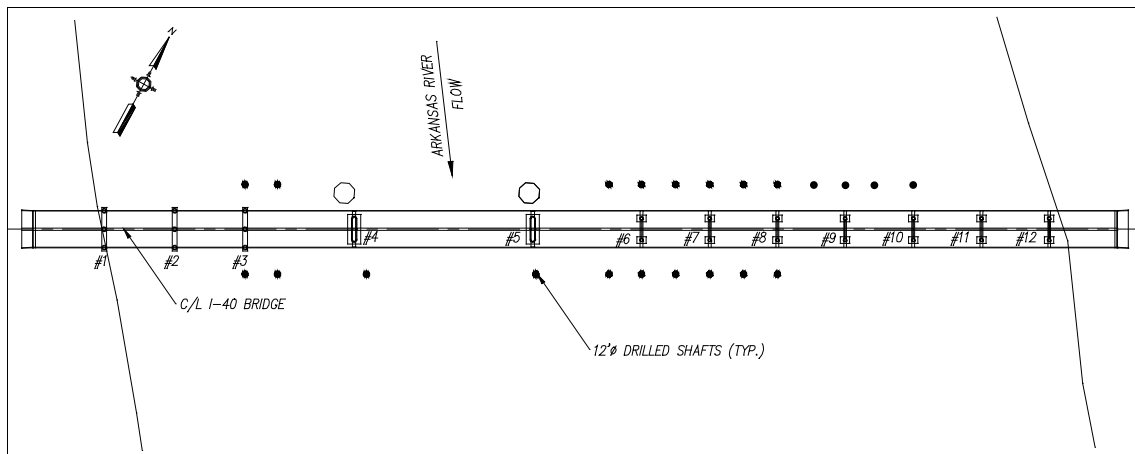
A vertical clearance of 50.25 feet from the 2% flowline elevation (EL. +469.5) and 61.5 foot from the pool elevation (EL. +460.0) is provided in the 300-foot-wide navigation channel. Figure 2.1-3 shows an elevation view of the channel span with the available navigation clearances. Additional site and bridge information is included in the previous study report.



**Figure 2.1-3: Elevation View of the Navigation Channel of the Bridge**

Following the barge collision with Pier 3 on May 26, 2002, several modifications were made to the bridge as part of the emergency repair plans. Spans 1, 2, and 3 were replaced with prestressed concrete beams. A section of span 4 was also replaced, with new plate girders spliced onto the remaining existing ones. Also, Piers 1, 2 and 3 were replaced with bents consisting of three 108-inch diameter drilled shafts with a web wall. Abutment 1 and the west approach slab were also replaced.

The emergency repairs were later followed by the construction of additional pier protection consisting of 12-foot diameter drilled shafts placed at selected locations upstream and downstream of the bridge as shown in Figure 2.1-4.



**Figure 2.1-4: Bridge Plan View Showing Additional 12-Foot Diameter Drilled Shafts Protection**

## 2.2 Design Criteria

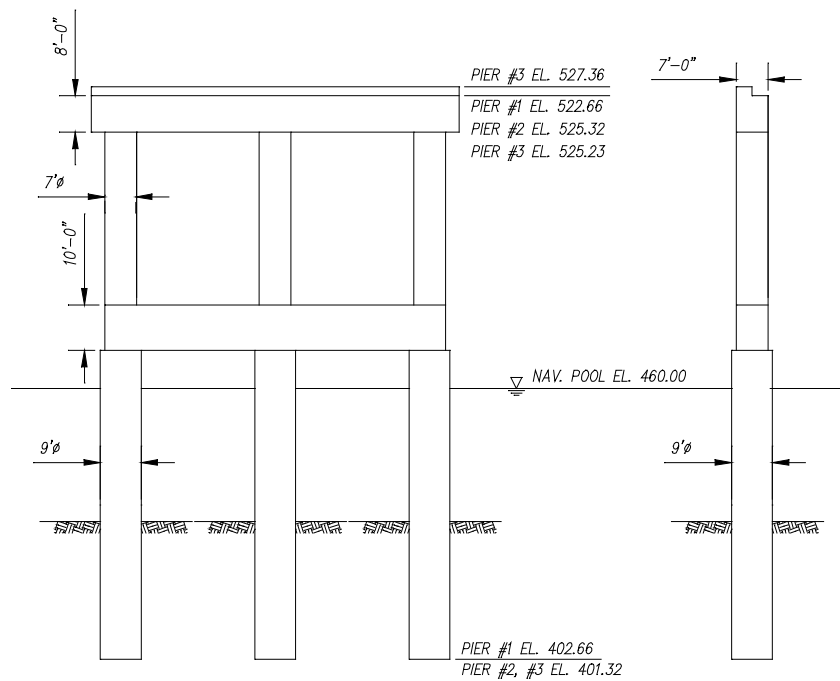
The original bridge design was completed in 1965 prior to the development of criteria for vessel collision design. Two dolphins on the upstream side of the bridge were provided in 1983 to protect the piers adjacent to the navigation channel.

The additional pier protection was designed for an impact load of 2,400 kips from a 3 barge long loaded hopper barge tow traveling at 6 mph (5.2 knots), or from larger barge tows through plastic deformations.

The vessel collision risk assessment update follows the current American Association of State Highway and Transportation Officials (AASHTO) LRFD, 9<sup>th</sup> 2020 Ed (2009) and the AASHTO Guide Specifications and Commentary for Vessel Collision Design of Highway Bridges, 2nd Ed. with 2010 Interim Revisions.

## 2.3 Piers, Footing Depth and Soil Information

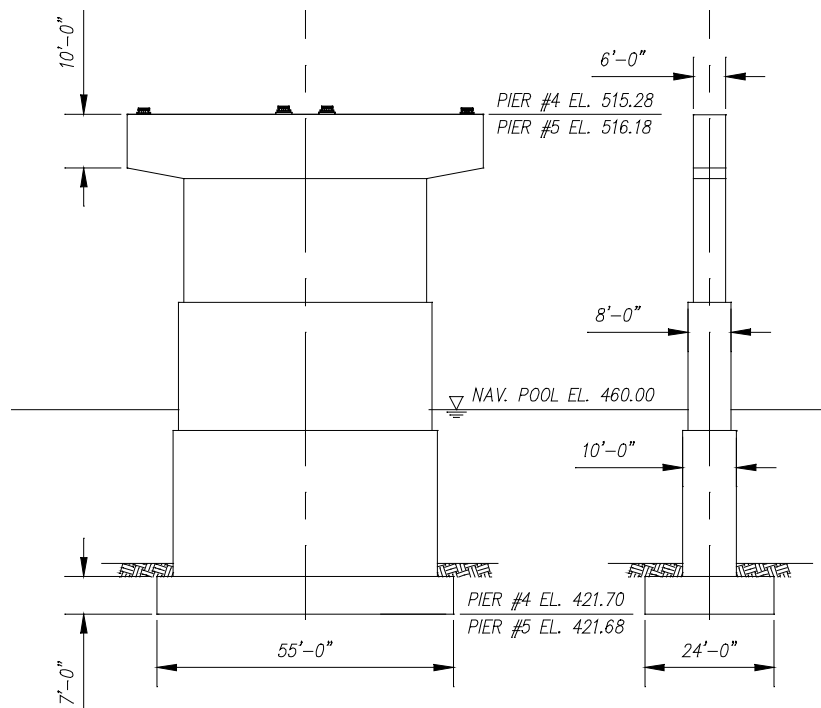
The piers exposed to vessel access include Piers 2 through 9. Piers 1 thru 3 are three column concrete piers with a concrete web wall, as shown in Figure 2.3-1. The upper portion of the pier consists of three 7-foot diameter columns and an 8-foot-deep pier cap. The columns, which are connected by a 7-foot-thick web wall in between, rest on 9-foot diameter drilled shafts. The drilled shafts are typically founded around Elevation 401, 27 feet within a layer of hard shale.



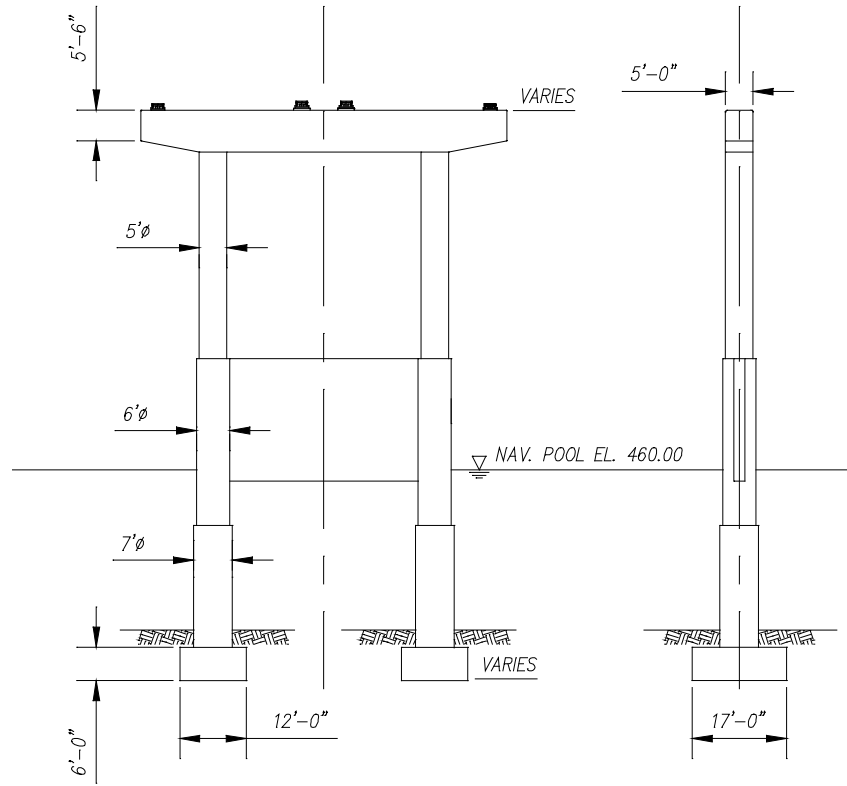
**Figure 2.3-1: Pier 3 Shown, Piers 1 & 2 Similar**

Piers 4 and 5, which are adjacent to the navigation channel, are solid concrete piers, resting on spread footings, as shown in Figure 2.3-2. The spread footings, which are 55 feet long, 24 feet wide and 7 feet deep, are founded at Elevation 421.7 within a layer of hard shale.

Piers 6 thru 12 are two column concrete piers with a concrete web wall, as shown in Figure 2.3-3. The upper portion of the pier consists of two 5-foot diameter columns and a 7-and-a-half-foot deep pier cap. The middle portion of the pier has two 6-foot diameter columns with a 2-foot-thick web wall in between, followed by two 7-foot diameter columns. The 7-foot diameter columns rest on spread footings which are 17 feet long, 12 feet wide and 6 feet deep. The spread footings are typically founded between Elevation 420 and 430 within a layer of hard shale.



**Figure 2.3-2: Piers 4 and 5**



**Figure 2.3-3: Piers 6 thru 13**

## 2.4 Existing Protection

The original bridge protection that included two 40-foot diameter steel sheet pile dolphins located directly upstream from the channel piers (Piers 4 and 5) is shown in Figure 2.4-1 and some of the additional 12-foot drilled shaft protection can be seen in Figure 2.4-2.



**Figure 2.4-1: Sheet Pile Dolphins Upstream of Piers 4 and 5**



**Figure 2.4-2: View of the 12-Foot Drilled Shaft Protection on the Downstream Side of the Bridge**

## 2.5 Upstream and Downstream Lock and Dams

Figures 2.4-3 and 2.4-4 include views of the Webbers Falls Lock and Dam located 6.3 miles upstream from the bridge and the Robert S. Kerr Lock and Dam located 24.1 miles downstream from the bridge. These locks control the river conditions at the site and the access of drifting and out of control vessels to the bridge. They are also a good source of information on the vessel traffic passing the bridge.



**Figure 2.4-3: View Webbers Falls Lock and Dam 16 Located 6.3 miles Upstream from the Bridge**



**Figure 2.4-4: View Robert S. Kerr Lock and Dam 15 Located 24.1 miles Downstream from the Bridge**

### 3. RISK FACTORS AND HISTORICAL ACCIDENT DATA

#### 3.1 General

The risk of vessel collision with a bridge reflects both the likelihood of a collision and its consequences. The factors involved are related to the following events: 1) an approaching vessel becomes aberrant and strays off course in the vicinity of a bridge, 2) the aberrant vessel is on a collision course with one of the bridge piers, and 3) the pier impact results in serious bridge damage or collapse. These factors are affected by the waterway and navigation conditions, the vessel characteristics, and the bridge location, geometry and strength characteristics.

Data on the history of marine accidents in a given waterway region can provide information on how likely it is for a vessel to lose control while approaching a bridge crossing and potentially strike it. In addition, it can help identify collision prevention measures. Loss of vessel control can result in groundings, collisions with other vessels or collisions with fixed structures. Note that in the maritime industry the term collision is only used to refer to impact between two vessels, while the term allision (or ramming) is used for impact of a vessel with a fixed structure (e.g. a ship with a bridge pier, lock or docked vessel).

The main causes of marine accidents can generally be grouped into mechanical/electrical failure, human error and environmental conditions categories. The role of the environmental conditions in an accident is somewhat subjective since in many cases adverse environmental conditions can be regarded as merely influencing factors to the human error category. Other influencing factors include waterway conditions, bridge characteristics, and vessel traffic and navigation conditions.

The majority of the bridge collision accidents reported occurred on only a few of the waterways and mainly at certain locations, which usually have little margin of navigation error. The most common bridge collisions involved a bridge near a bend during high water periods, a movable bridge with a narrow span opening or several bridge crossings next to each other. At most locations the accidents were frequent, and the damage was not significant.

However, a review of only the more serious and rare accidents indicates that they have mainly occurred at unexpected locations and that the general findings based on the statistics of all reported incidents are not always representative. The May 26, 2002 barge tow collision with the I-40 Bridge fits this pattern. The barge tow involved veered off course as it was approaching the bridge because of the captain of the towboat becoming incapacitated.

### 3.2 Update of Historical Marine Incidents on the Arkansas and Verdigris River

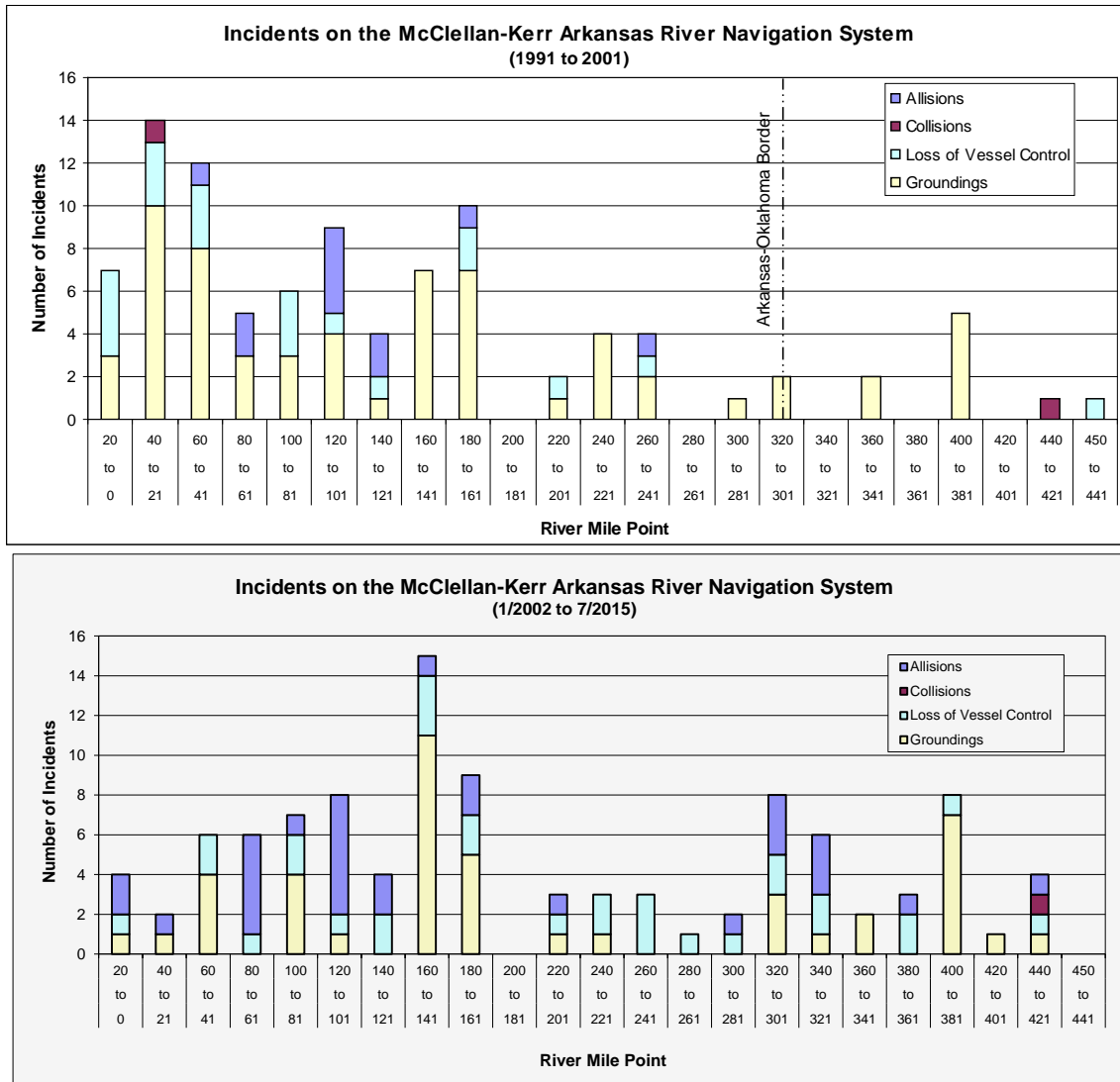
In order to assess the likelihood of vessel aberrancy on the McClellan-Kerr Arkansas River Navigation System in Oklahoma, a special search and analysis of vessel incidents involving collisions, allisions, loss of vessel control and groundings in the Verdigris and Arkansas rivers from 1991 through 2001 was conducted as part of the 2005 study. An updated search and analysis of vessel incident data after 2001 was conducted as part of this study to evaluate any changes in the pattern and frequency of incidents.

The vessel incident information prior to 2005 was obtained primarily from the available volumes of the *United States Waterway Data* CDs. These CDs, which are published annually by the U.S. Army Corps of Engineers, contain files that are a compilation of U.S. waterway data from multiple sources, including the Navigation Data Center, the Bureau of the Census, and the U.S. Coast Guard. One section of data that is available on the CD is the U.S. Coast Guard Marine Casualty and Pollution Investigations. The data in these files are extracted from the Marine Safety Information System (MSIS) database, which is a database of marine casualty and pollution investigation reports conducted by U.S. Coast Guard investigators. The data was supplemented by a query made in the U.S. Department of Transportation, Bureau of Transportation Statistics database, TranStats. Because the TranStats reports do not include the location of the incident on the river or river mile, a special request was made to the U.S. Coast Guard, under the Freedom of Information Act, to search their main database and retrieve the river mile points for the incomplete records.

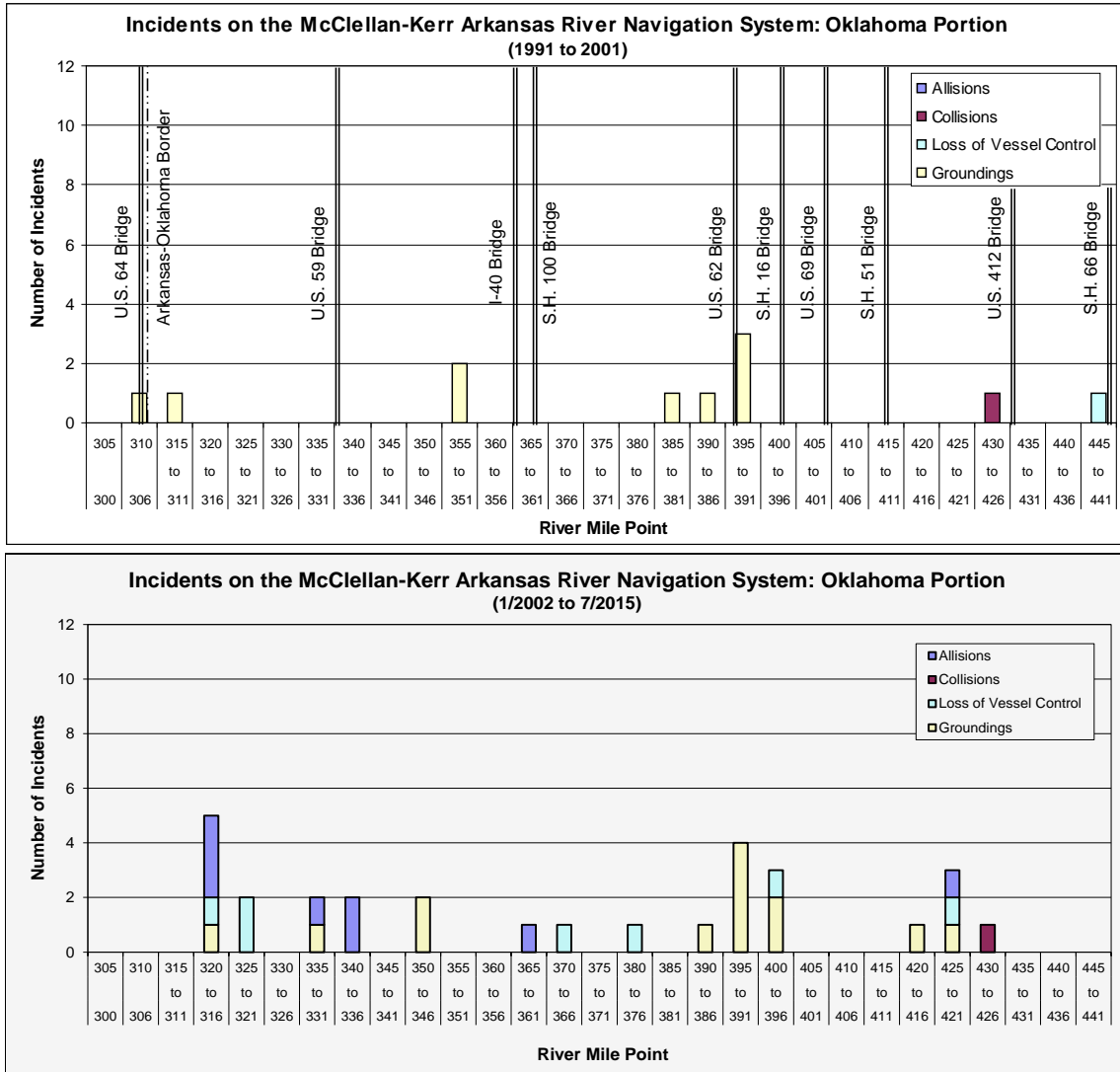
Information on marine incidents on the McClellan-Kerr Arkansas River Navigation System after 2001 was obtained from databases and reports available from USACE, USCG and NTSB (National Transportation Safety Board), internet searches and bridge owner inquiries. The USCG marine incident data available to download from [Marine Casualty and Pollution Data for Researchers \(uscg.mil\)](http://www.uscg.mil) contains marine casualty and pollution data investigated by Coast Guard Offices throughout the United States including data from January 2002 through July 2015. The files available contain a variety of factors including vessel or facility type, injuries, fatalities, pollutant details, location, and date for each incident. More detailed information on each incident was obtained from the USCG incident investigation report search database using the corresponding incident activity number ID ([CGMIX IIR Search Page \(uscg.mil\)](http://www.uscg.mil)).

Figures 3.2-1 and 3.2-2 show the number, type and location of reported incidents before 2001 (top plots) and after 2001 (bottom plots) by river mile. Figure 3.2-1 contains incident data for the entire system, with a line representing the Arkansas-Oklahoma border that has been added to differentiate the two sections. It shows a significant decrease in the number of incidents that occurred in Oklahoma compared to Arkansas. The bottom plot in Figure 3.2-1 shows a larger relative number of incidents in the Oklahoma portion of the waterway relative to the previous time period, but the general trend of more incidents occurring in the Arkansas portion remains.

Figure 3.2-2 concentrates on the Oklahoma portion of the waterway, with additional lines symbolizing bridge locations. It shows that most of the incidents were groundings occurring away from bridge locations. The bottom plot in Figure 3.2-2 shows a wider mix of incident types along the waterway with most of the allisions and groundings occurring near or at locks, still away from bridge locations.



**Figure 3.2-1: USCG Accident Analysis (1991 to 2001 top and 1/2002 to 7/2015 bottom): Incidents on the McClellan-Kerr Arkansas River Navigation System by River Mile Range**



**Figure 3.2-2: USCG Accident Analysis (1991 to 2001 top and 1/2002 to 7/2015 bottom): Incidents on the McClellan-Kerr Arkansas River Navigation System by River Mile Range: Oklahoma Portion**

The total number of incidents by type and state is summarized in Tables 3.2.1 for both the time period before 2001 (top table) and after 2001 (bottom table). The data shows that for both time periods groundings are the most prevalent accident type, both for the entire system and for each state individually. Collisions are the least frequent, with only one incident in each state for both time periods review. Also, the data shows that there were very few collisions with bridges on the Oklahoma portion of the waterway and most of the allisions in both states involved locks.

**Table 3.2-1: USCG Accident Analysis (1991 to 2001 top and 1/2002 to 7/2015 bottom): Accident Type by State for the McClellan-Kerr Arkansas River Navigation System**

| <b>Accident Type (1991 to 2001)</b> |                             |                               |                  |                  |                                   |              |
|-------------------------------------|-----------------------------|-------------------------------|------------------|------------------|-----------------------------------|--------------|
| <b>State</b>                        | <b>Allision w/<br/>Lock</b> | <b>Allision w/<br/>Bridge</b> | <b>Grounding</b> | <b>Collision</b> | <b>Loss of Vessel<br/>Control</b> | <b>Total</b> |
| Arkansas                            | 7                           | 4                             | 55               | 1                | 19                                | 86           |
| Oklahoma                            | 0                           | 0                             | 8                | 1                | 1                                 | 10           |
| Total System                        | 7                           | 4                             | 63               | 2                | 20                                | 96           |

| <b>Accident Type (1/2002 to 7/2015)</b> |                             |                               |                  |                  |                                   |              |
|---|-----------------------------|-------------------------------|------------------|------------------|-----------------------------------|--------------|
| <b>State</b>                            | <b>Allision w/<br/>Lock</b> | <b>Allision w/<br/>Bridge</b> | <b>Grounding</b> | <b>Collision</b> | <b>Loss of Vessel<br/>Control</b> | <b>Total</b> |
| Arkansas                                | 17                          | 5                             | 31               | 0                | 23                                | 76           |
| Oklahoma                                | 7                           | 1                             | 13               | 1                | 7                                 | 29           |
| Total System                            | 24                          | 6                             | 44               | 1                | 30                                | 105          |

Both the previous and the updated accident data on the Verdigris and the Arkansas River generally confirms the tendency for accidents to cluster at certain locations along the waterway, as found in previous studies. Many of the accidents occurred at lock & dam structures, which are not representative of the conditions at bridge crossings.

Given that the more recent data covers a longer period of time than the previous time period, it can be concluded that there has not been an increasing trend in the frequency of marine accidents and as stated in the previous report, relative to other waterways, the frequency of marine incidents on the McClellan-Kerr Arkansas River Navigation System is quite low and even lower in the Oklahoma portion.

### **3.3 Marine Accidents at the Bridge Site**

From 1991 through 2001, which is the previous review period of vessel incidents on the Verdigris and Arkansas rivers, there were no accidents reported within a ten-mile range of the I-40 Bridge.

On May 26, 2002, the M/V Robert Y. Love was traveling upstream on the Arkansas River, pushing two tank barges. The barge tow began to veer to the left while approaching the I-40 Bridge site traveling out of the channel toward the west bank, and it struck the south column of Pier 3. The estimated speed of the barge tow was 6.7 mph (9.8 ft/sec) and the river current estimate was about 2 mph (3 ft/sec). The impact caused the collapse of Spans 1, 2, and 3 and a section of Span 4. The cause of the collision was attributed to the captain of the towboat becoming incapacitated.

Prior to the May 2002 accident, there was only one previous reported bridge collision case of a barge hitting one of the channel piers of the I-40 Bridge before 1983. In this accident, one of the channel piers was hit by a barge tow traveling downstream. The pier experienced some cracking but resisted the impact load.

### 3.4 Marine Accidents due to Barge Breakaways

Barge breakaways can occur during high water periods when barges can break loose from their moorings at docks, and also as a result of other incidents such as collisions, allisions and groundings.

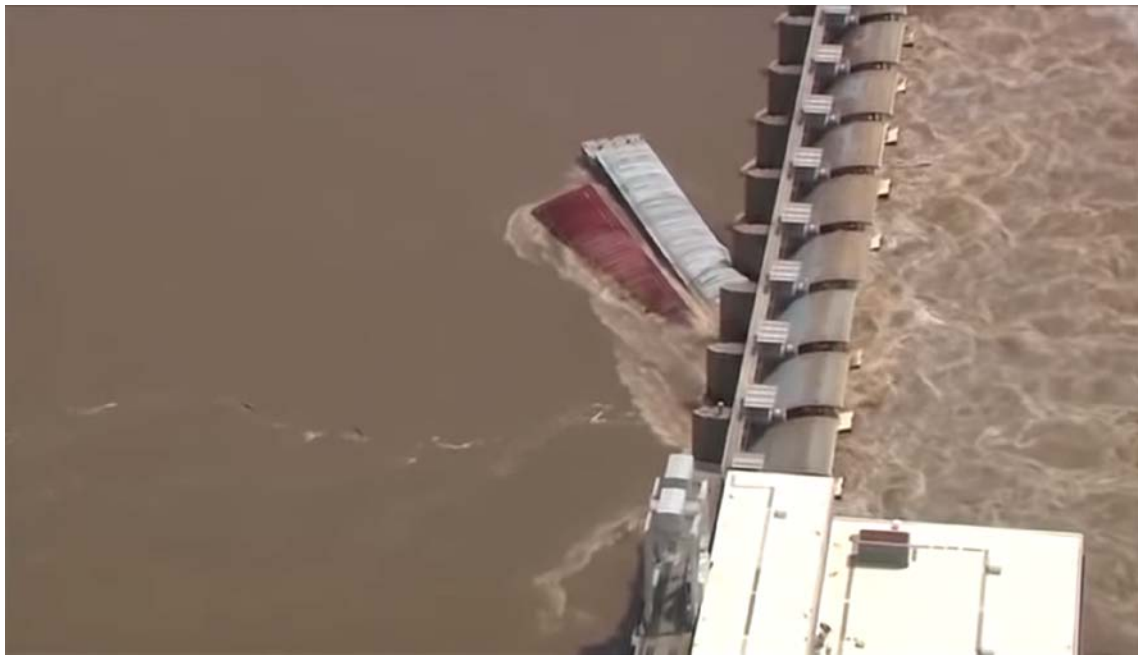
AASHTO addresses barge breakaways by specifying a minimum impact load due to an empty hopper barge travelling at a speed equal to the yearly mean current for the waterway location. However, a review of past accidents due to barge breakaways shows that a more conservative approach that accounts for loaded barge breakaways and higher barge speeds that reflect the actual current speeds during high water events is needed.

An example of a barge breakaway near the I-40 bridge involved barge MST-720 B, which broke free from the Consolidated Grain & Barge facility in Webbers Falls, Oklahoma on July 13, 2004, and drifted downstream. It was caught by M/V Fayville only about 3/4 of a mile from the I-40 Bridge. Barges broke free at this facility during the May 2019 flood as well (see Figure 3.2-1).



**Figure 3.2-1: View of Barges that Broke Free from the Consolidated Grain & Barge Facility During the 2019 Flood**

The May 2019 flood caused another barge breakaway that resulted in an allision at the Webbers Falls Lock & Dam, when two loaded barges, MTC 7256 and LTD 11140, struck the Webbers Falls Dam. The barges broke away from a fleeting area on the Grand River in Muskogee, Oklahoma, during high flood waters and high river current. The river current velocity at Muskogee was about 5 ft/sec. There was no damage to the dam, but the two barges were a total loss, as shown in Figure 3.4-2.



**Figure 3.2-2: Runaway Barges MTC 7256 and LTD 1140 Shortly Before and After Striking Webbers Falls Dam.**

## 4. WATERWAY CHARACTERISTICS AND ENVIRONMENTAL CONDITIONS

### 4.1 General

Adverse waterway characteristics and environmental conditions have a direct influence on the navigation conditions and the probability of vessel aberrancy. Accident statistics indicate that adverse waterway and environmental conditions such as awkward channel alignment, poor visibility conditions (fog or rainstorms), strong currents, and wind squalls are common influencing factors in vessel collision accidents.

This section provides an update of the waterway characteristics presented in the 2005 vessel collision study report.

### 4.2 Channel Layout and Geometry

The McClellan-Kerr Arkansas River Navigation System (MCKARNS) is maintained as a 9-foot-deep draft navigation channel. The river at the I-40 Bridge is approximately 1,400 feet wide, and the navigation channel is 300 feet wide.

The I-40 Bridge is located on the Arkansas River section of the McClellan-Kerr Arkansas River Navigation System, at river mile 360.3. There are bends in the channel on both the upstream and downstream sides of the bridge. A 31° bend is located approximately 1,375 feet on the upstream side of the bridge, and a 24° bend is located approximately 3,240 feet on the downstream side of the bridge. Also, there are several intersecting waterways on both sides of the channel. The bridge is aligned slightly skewed relative to the channel as shown in Figures 4.2-1.

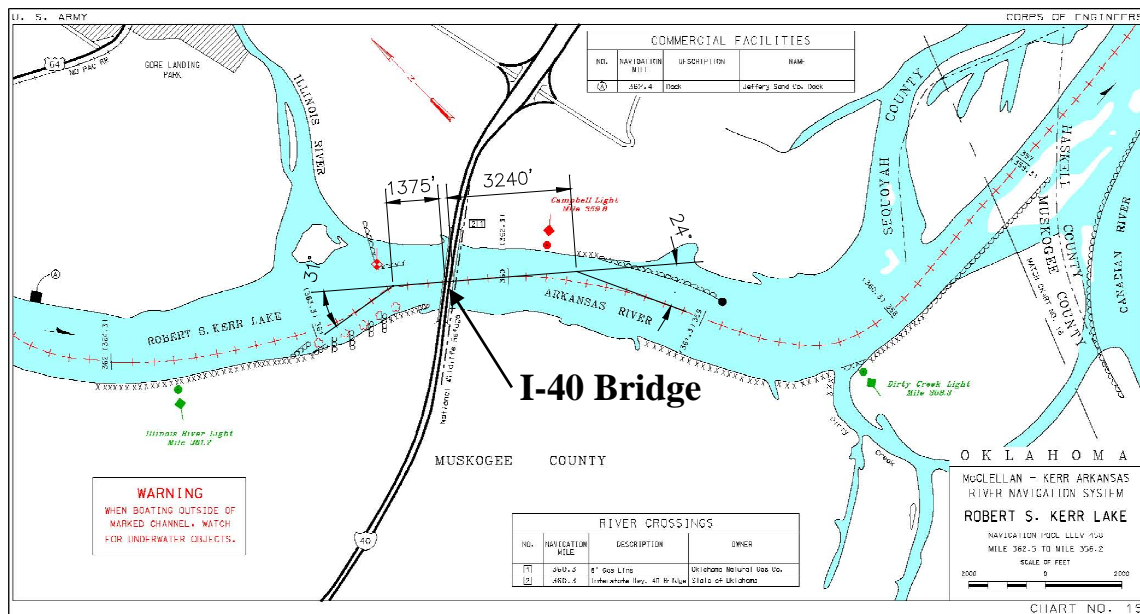
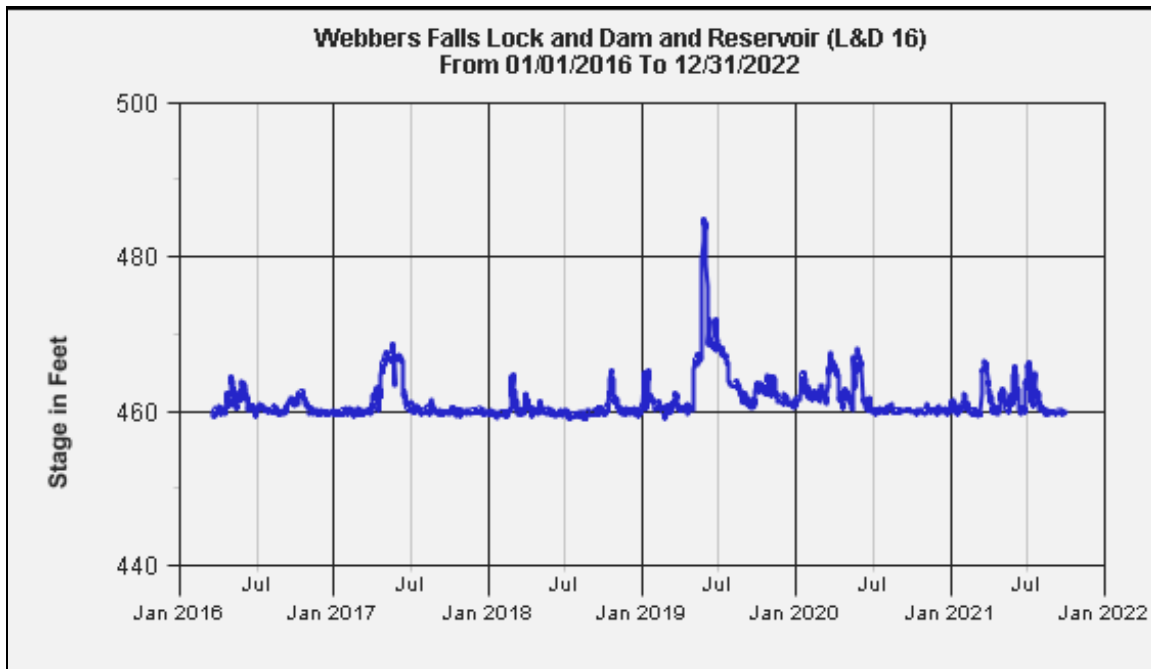


Figure 4.2-1: Navigation Chart Showing Channel Bends (USACE)

### 4.3 Water Depth and Fluctuations

As noted in the 2005 Report, except for extreme events, water levels on the McClellan-Kerr Arkansas River Navigation System vary little since they are controlled by the 17 lock and dam structures. A comparison of the waterway data before and after the previous study report confirmed that during normal times water levels do not vary much, but it also showed a higher frequency of high-water events during the more recent time period. As a result an increased water level variability is apparent. This is shown in Figure 4.3-1, which is a representative hydrograph of the pool elevation readings at the Webbers Falls Lock and Dam. The pool flood stage at the Lock and Dam is 490.5.



**Figure 4.3-1: Updated Pool Elevations at the Webbers Falls Lock and Dam from 1/1/2016 to 3/22/2022**

As a flood event occurs, the flow is constricted at the dam, and this causes the river profile to rise upstream of the dam as the water “backs up”. When a flood does occur, the navigation system is closed in advance of the water levels reaching the lock machinery. The last flood event that forced a closure of the locks and dams on the system occurred in 2019 and the previous one in 1990.

The United States Geological Survey (USGS) operates a stream gaging station upstream from the bridge site, near Muskogee, Oklahoma and downstream of the bridge at Ft. Smith, Arkansas with comprehensive river data monitoring. Figure 4.3-2 shows historical daily discharge readings for these stations for the last 20 years or so. It shows the increased frequency of extreme events during the more recent times.

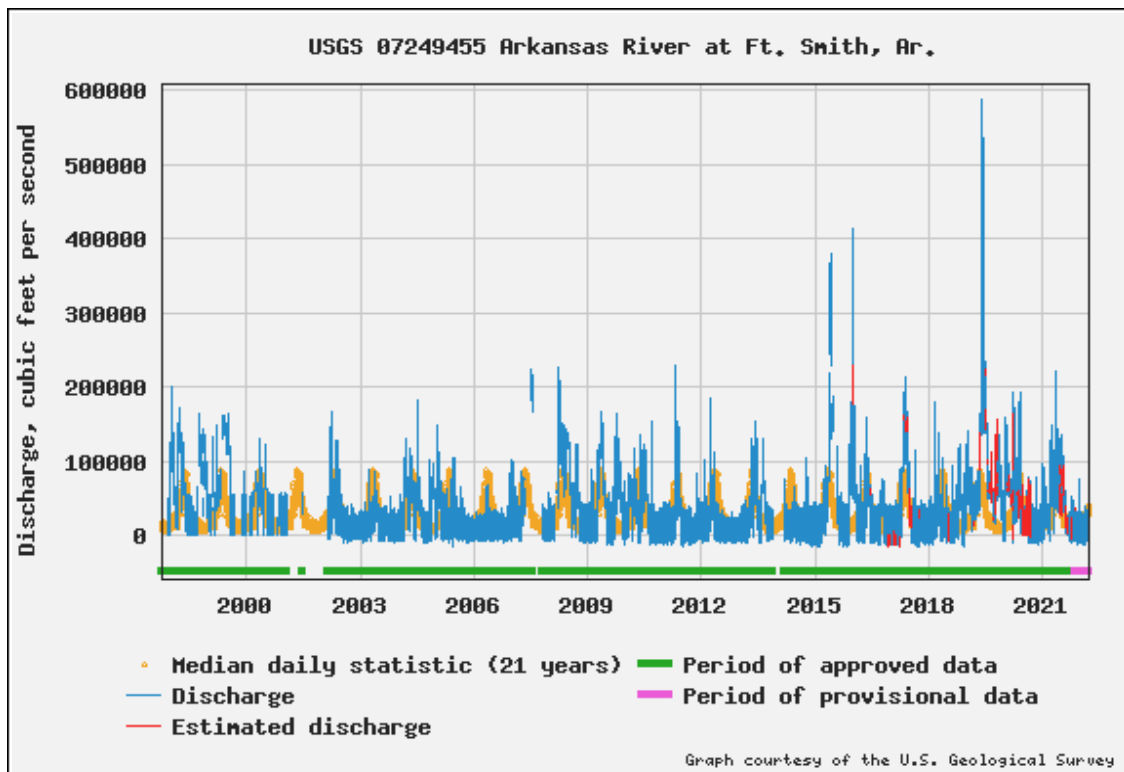
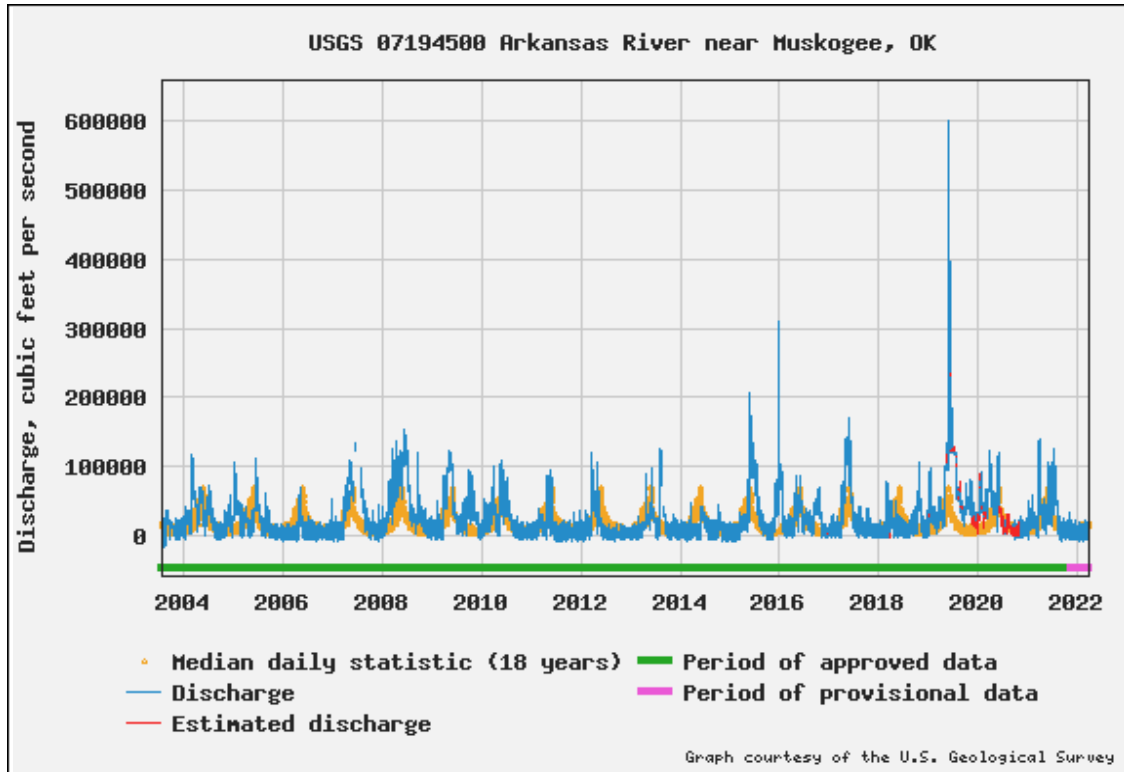
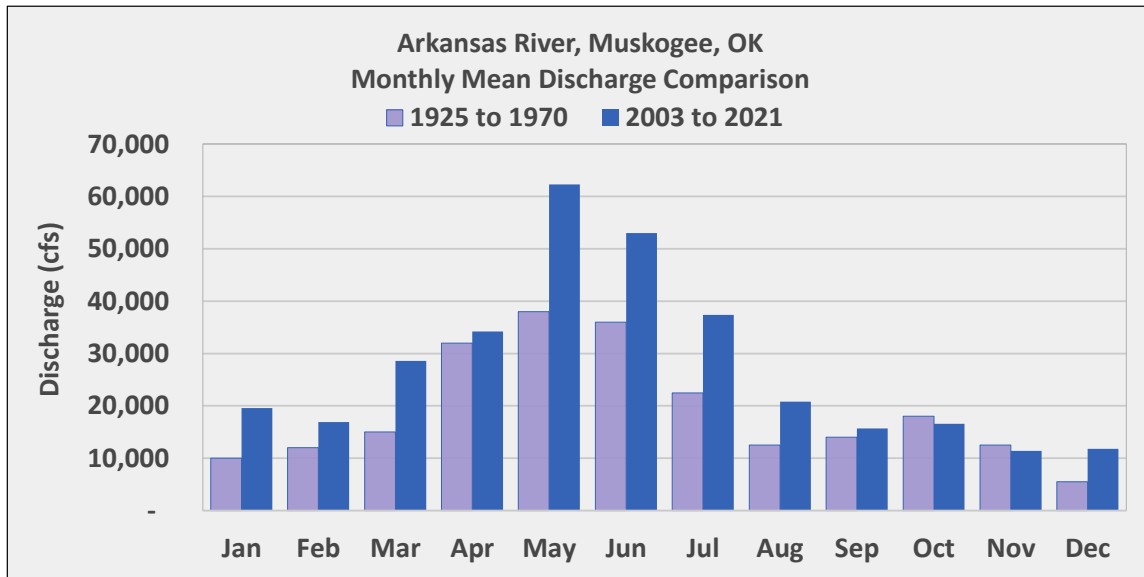


Figure 4.3-2: Historical Daily Discharges at Muskogee, OK (top plot) and Ft. Smith, AR (bottom plot)

A comparison of the monthly mean discharge data before 1970 and after 2003 is shown in Figure 4.3-3. A significant increase in discharge can be noted during the high discharge months of May, June and July.



**Figure 4.3-3: Comparison of Mean Monthly Discharge Readings at Muskogee, OK Between Time Periods 1925 to 1970 and 2003 to 2021**

#### 4.4 Current Direction and Velocities

The channel geometry at the site is illustrated in Figures 4.2-1 and 4.2-2. As noted in the previous report the river flow is slightly skewed relative to the bridge and no significant cross currents are apparent. The current velocity varies from very low to as high as 6 feet per second during high-water events, but the average velocity remains below about 3 feet per second when taking the Ft. Smith data into account.

Updated river current velocity data statistics are shown in Figures 4.4-1 and 4.4-2. Figure 4.4-1 includes a histogram generated from the daily current velocity data available between 2016 and 2022. It shows that the most frequent current velocities at Muskogee are below about 2.5 feet per second and that the current velocities at Ft. Smith are higher and more frequent. The probability distribution of the current velocity is included in Figure 4.4-2. For example, Figure 4.4-2 shows that the probability of exceeding a current velocity of 3 feet per second is about 10% at Muskogee and about 40% at Ft. Smith. Based on the current velocity data statistics, the use of 6 feet per second for design purposes for a high-water event seems to be reasonable.

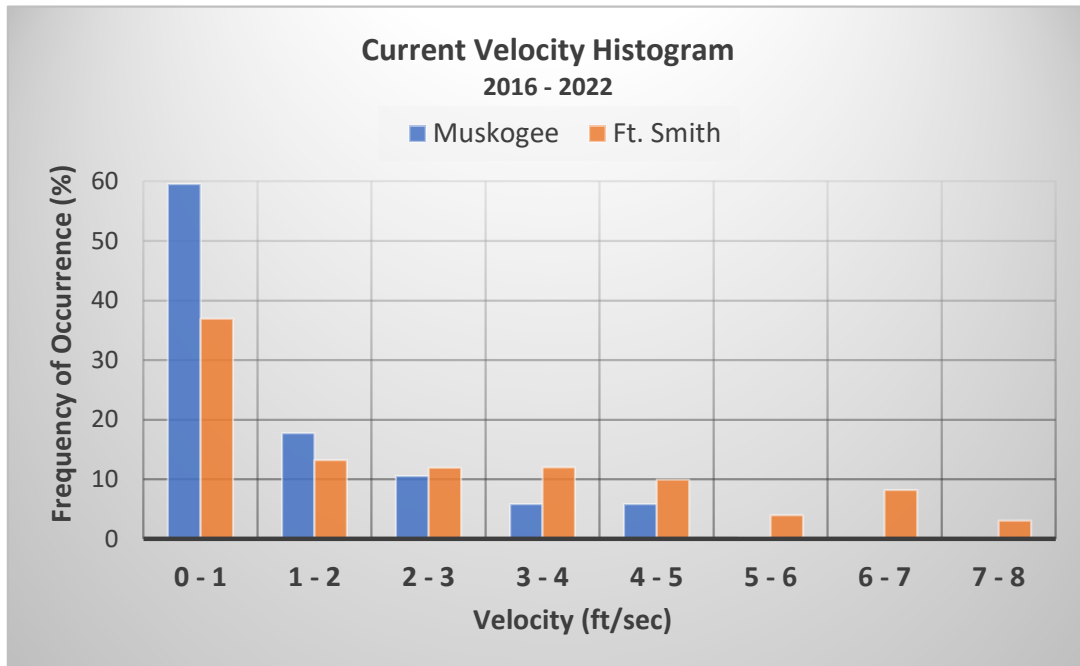


Figure 4.4-1 Current Velocity Histogram at Muskogee and Ft. Smith

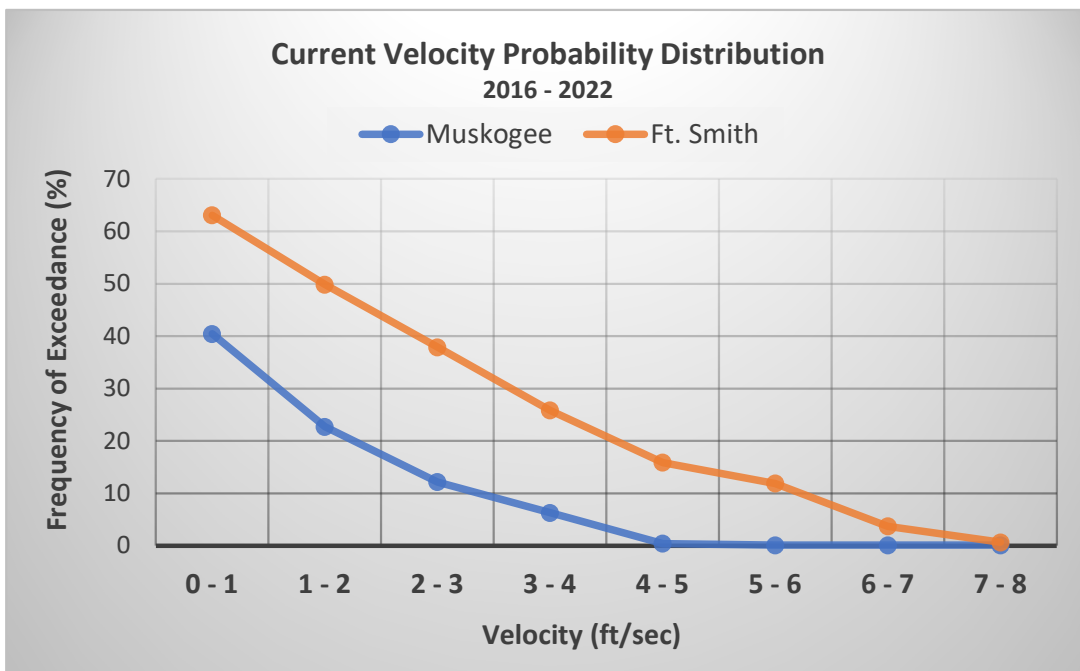


Figure 4.4-2 Current Velocity Probability Distribution at Muskogee and Ft. Smith

### 4.5 Conclusions

The updated waterway data suggests an increase in the frequency of high-water events during which barges can break loose from moorings. This further supports the recommendation made in Section 3.4 that a more conservative approach that accounts for loaded barge breakaways during high water and higher drifting barge speeds is needed.

## 5. UPDATE OF VESSEL AND TRAFFIC CHARACTERISTICS

### 5.1 Sources of Information

The update of the vessel traffic through the bridge was determined based on information from several sources including:

- U.S. Army Corps of Engineers (USACE) publications "Waterborne Commerce of the United States" (WCUS)
- LPMS Lock Statistic Summary Reports
- Special analysis conducted by the U.S. Army Corps of Engineers Navigation Center Lock Performance Monitoring System (LPMS) at our request
- Past-the-point analysis conducted by the U.S. Army Corps of Engineers Waterborne Commerce Statistics Center (WCSC)
- Ports of Muskogee and Oakley's Port 33
- Interview with Webbers Lock and Dam Personnel
- Oklahoma Department of Transportation Waterways Branch
- USACE McClellan-Kerr Arkansas River Navigation Systems Operations

### 5.2 Vessel Types

The vessel types on the McClellan-Kerr Arkansas River navigation system include mainly hopper and tanker barge tows. A view of a typical hopper barge tow in transit is shown in Figure 5.2-1, and a view of a typical tanker barge tow in a lock chamber is shown in Figure 5.2-2.



**Figure 5.2-2: Typical Hopper Barge Tow in Transit**

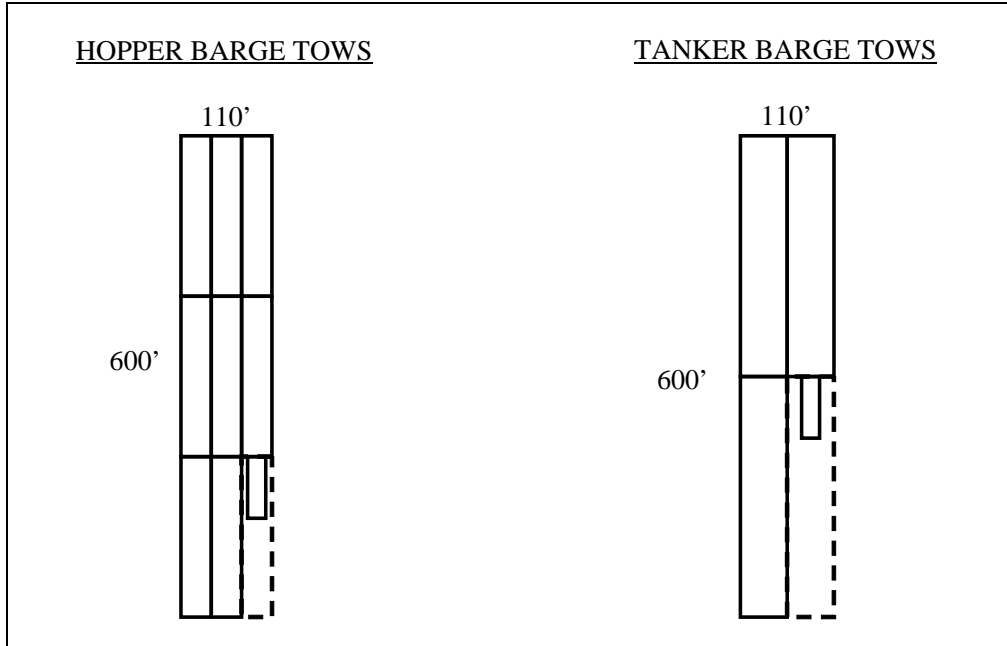


**Figure 5.2-3: Typical Tanker Barge Tow in Lock Chamber (Tow Entering the Choteau Lock (USACE))**

Hopper barges are typically 35 feet wide, 195 feet long and 12 feet deep and have a cargo capacity of about 1,700 tons. Large tanker barges are commonly 53 feet wide, 290 feet long and 12 feet deep, and have a dead weight of approximately 500 to 600 tons and a cargo capacity of up to about 3,700 tons. Thus, a typical tanker barge can carry over twice the tonnage of a hopper barge. The draft of both barge types can vary from 2 to 9 feet depending on their loading condition.

The size of the barge tows on the McClellan-Kerr Arkansas River navigation system is affected by the size of the locks in the system. All lock chambers are 110 feet wide and 600 feet long and can accommodate only 8 hopper barges or 3 tanker barges in one lockage, as illustrated in Figure 5.2-4.

It is not uncommon, however, for large tows to use a double lockage in which the tow is broken apart before the lockage and then assembled again. In general, the hopper barge tows include 4 to 6 barges and the tanker barge tows include 2 to 4 barges per tow. The largest hopper tows can include as many as 12 barges and the largest tanker tows can include as many as 6 barges per tow.



**Figure 5.2-4: Limit of Hopper and Tanker Barge Tows in One Lockage**

Figure 5.2-5 shows a 12-barge hopper barge tow broken in two to fit the Robert S Kerr Lock limits, and Figure 5.2-6 shows a tanker barge tow broken to fit the Webbers Falls Lock limits.



**Figure 5.2-5: Hopper Barge Tow at Robert S Kerr Lock and Dam 15**

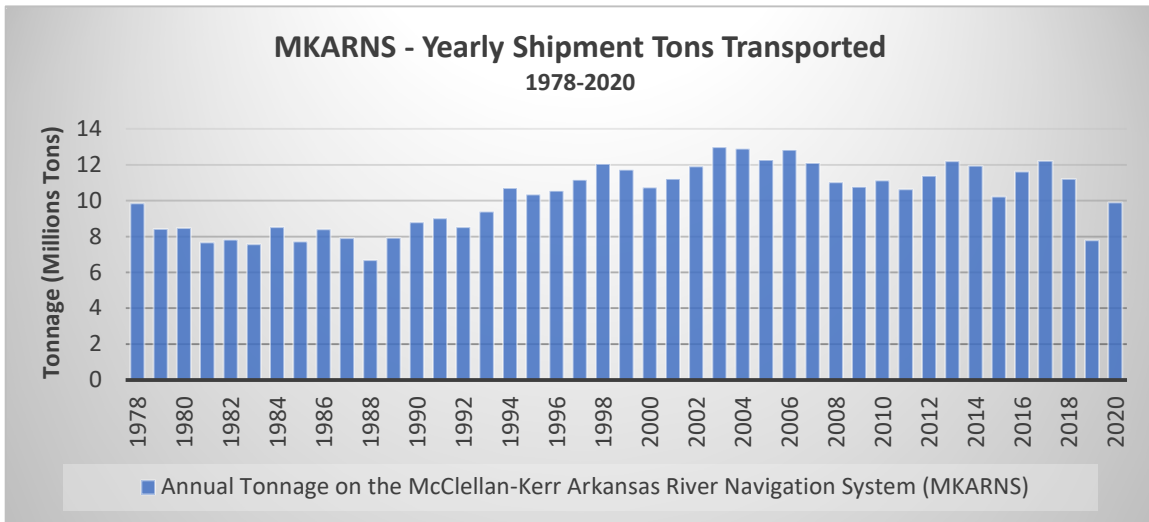


**Figure 5.2-6: Tanker Barge Tow at Webbers Falls Lock and Dam 16**

### 5.3 Historical Traffic Data

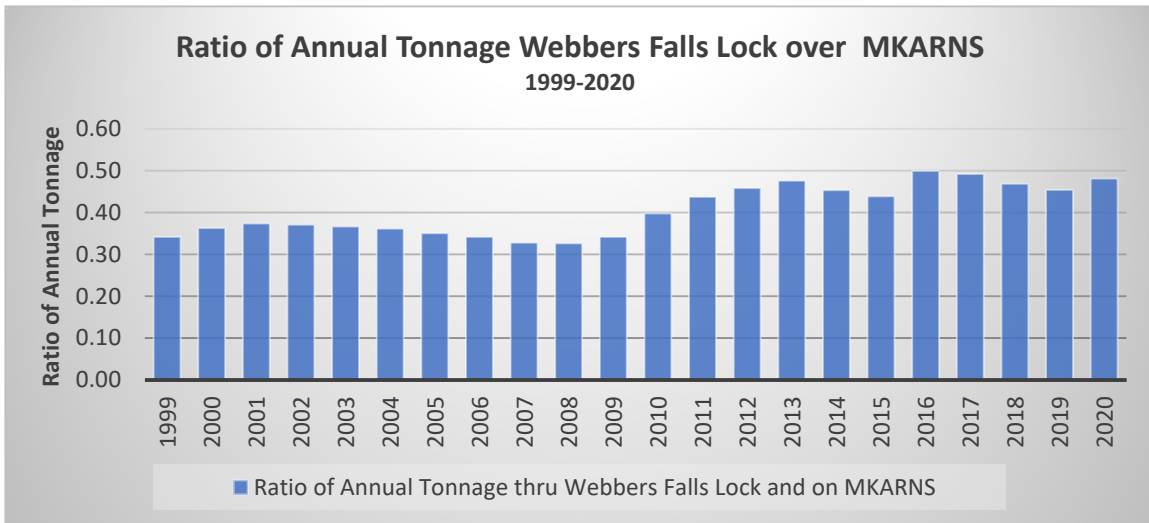
#### 5.3.1 Tonnage and Commodity Data

The historical information for updating the total volume of traffic on the McClellan-Kerr Arkansas River navigation system and locally at the I-40 Bridge was obtained from the USACE WCUS publications and the Webbers Falls Lock and Dam databases. Figure 5.3-1 includes the updated yearly tonnage of shipments transported on the McClellan-Kerr Arkansas navigation system since 1978. It shows that after the steady increase in traffic until about 1978, the traffic leveled off and except for some variations it remained relatively constant until 2018. A drop in traffic occurred in 2019 due to the significant flooding that occurred that year, and in 2020 due to the impact of COVID-19. Therefore, 2018 seems to be a more representative year for vessel traffic analysis.



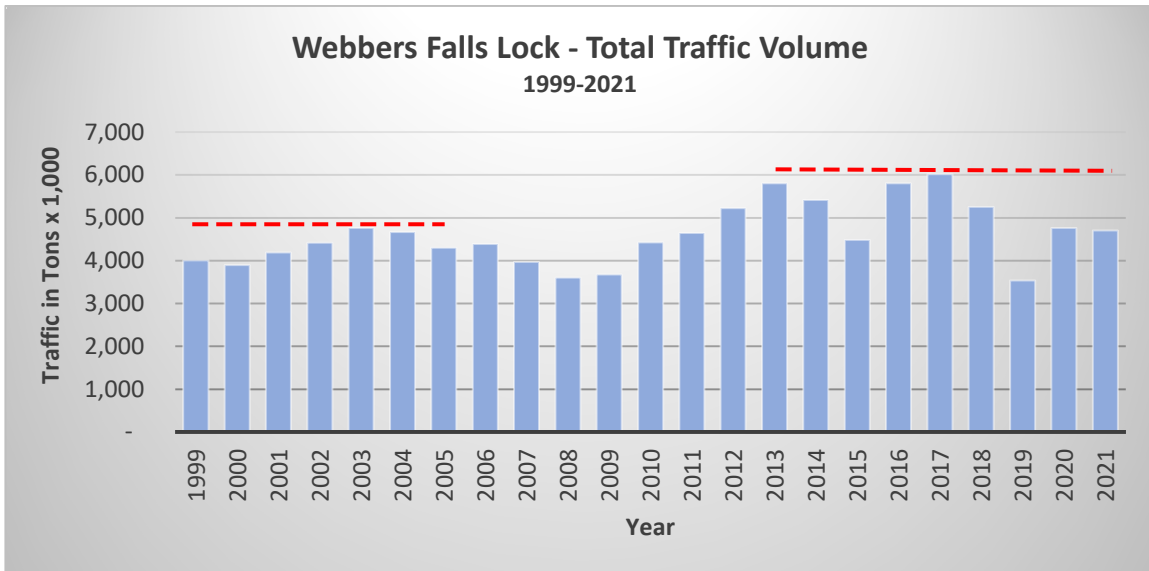
**Figure 5.3-1: Updated Yearly Tonnage Transported on the McClellan-Kerr Arkansas River Navigation System Traffic**

Only a portion of the total traffic passes the bridge site, and the traffic going through the Webbers Falls Lock is a good approximation of it. A plot of the ratios between the annual tonnage going through the Webbers Falls Lock and over the McClellan-Kerr Arkansas River Navigation System (MKARNS) since 1999 is included in Figure 5.3-2. It shows that the relative tonnage through the Webbers Falls Lock has increased since about 2010 reaching a relatively uniform percentage of close to 50% of the total tonnage transported on MKARNS.



**Figure 5.3-2: Ratio Between the Annual Tonnage through Webbers Falls Lock and Over the McClellan-Kerr Arkansas River Navigation System**

Figure 5.3-3 includes yearly vessel traffic tonnage that went through the Webbers Falls Lock since 1999. It shows that in average the volume of traffic over the recent time period since 2013 has increased from a maximum of about 5 million tons during the 6-year period prior to 2005 when the previous vessel collision study was performed, to a maximum of about 6 million tons.



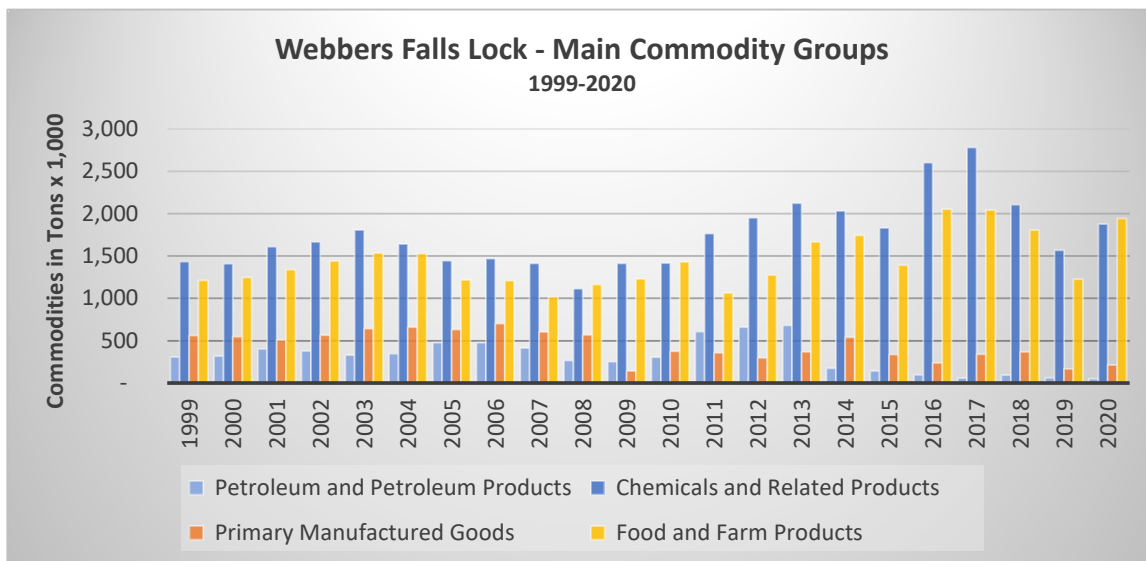
**Figure 5.3-3 Historical Marine Traffic Volume through Webbers Falls Lock (1999-2021)**

The volume of traffic is broken down into the following commodity groups:

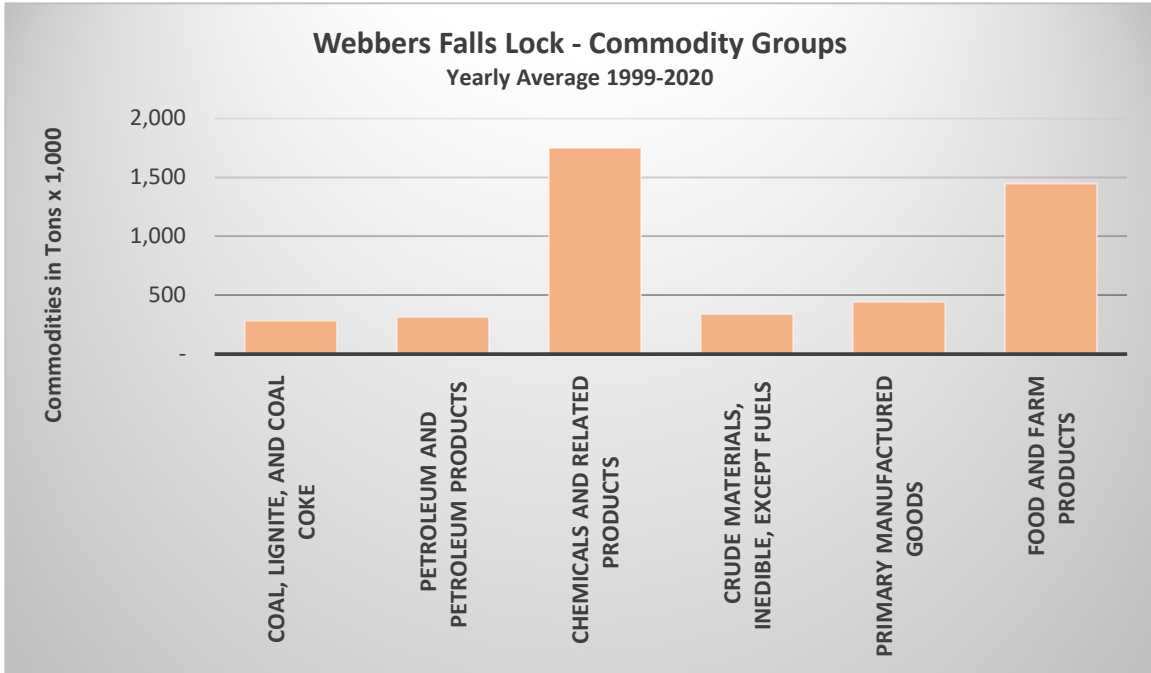
- Coal, Lignite, and Coal Coke
- Petroleum and Petroleum Products

- Chemicals and Related Products
- Crude Materials, Inedible, Except Fuels
- Primary Manufactured Goods
- Food and Farm Products
- Manufactured Equipment & Machinery
- Waste Material
- Unknown or Not Elsewhere Classified

The changes in the main commodity group tonnages between 1999 and 2020 are shown in Figure 5.3-4, and the changes in the traffic tonnages by commodity group averaged over the 1999-2020 time period are shown in Figure 5.3-5. These figures show that chemical and related products and food and farm products, which are the main shipments, have increased relative to the previous study period.

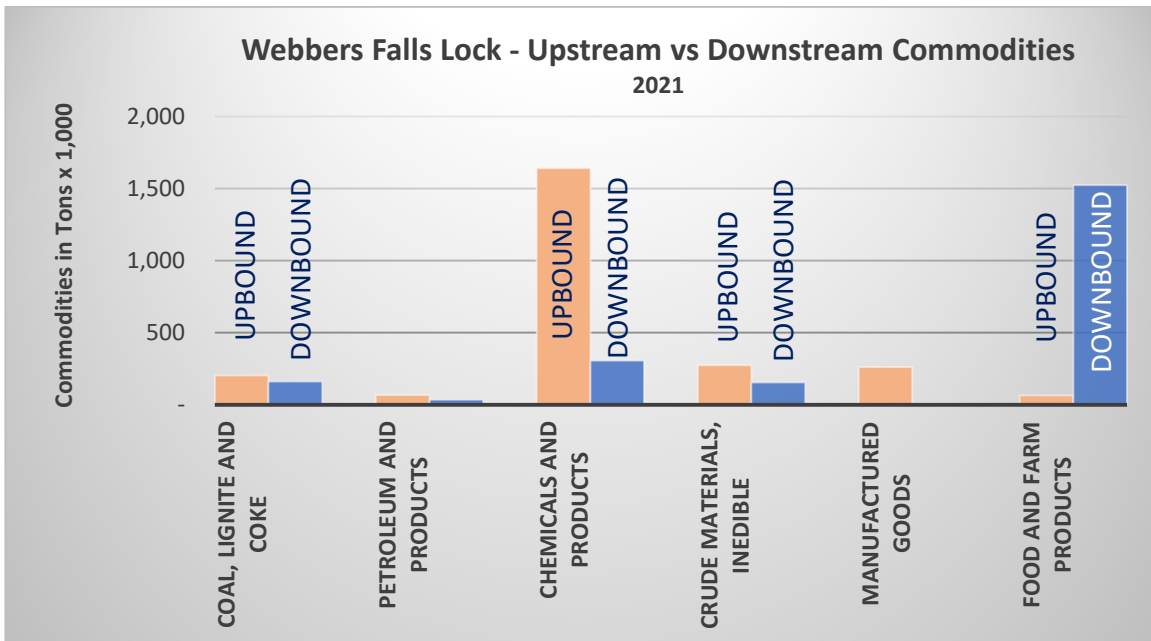


**Figure 5.3-4 Main Commodity Group Tonnages between 1999 and 2020**



**Figure 5.3-5 Marine Traffic Volume by Commodity Group (1999-2020)**

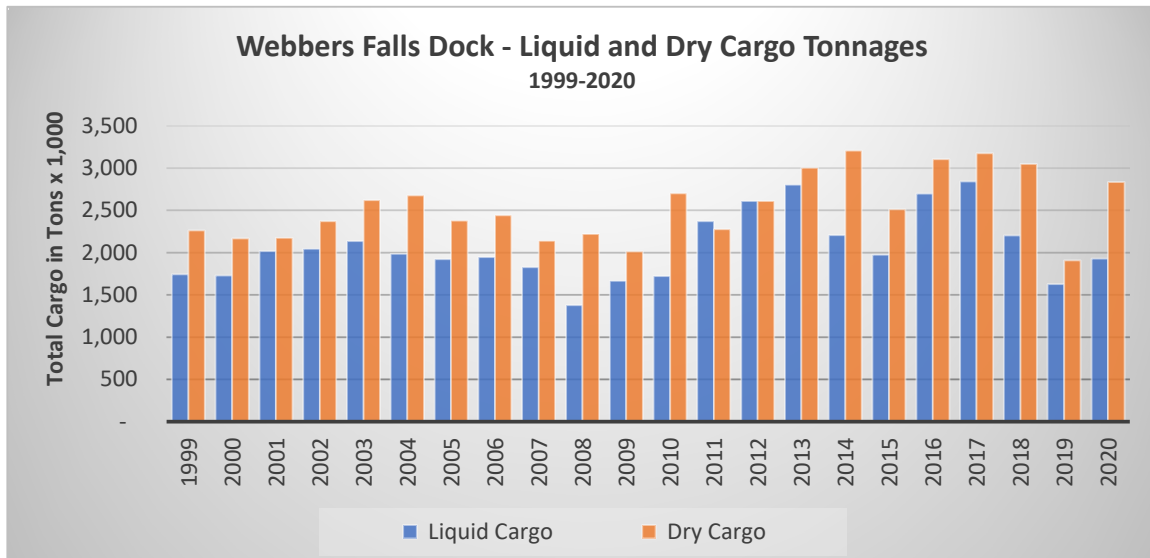
Figure 5.3-6 separates the commodity tonnages by direction of traffic and shows that the shipments of chemicals and related products are mainly upbound and the shipments and food and farm products are downbound.



**Figure 5.3-6 Marine Traffic Volume by Commodity Group and Direction of Traffic**

Figure 5.3-7 separates the changes in commodity tonnages by Liquid Cargo and Dry Cargo for vessel collision analysis purposes since the Liquid Cargo is carried in

Tanker Barge Tows and the Dry Cargo in Hopper Barge Tows, each having their unique vessel collision related characteristics.



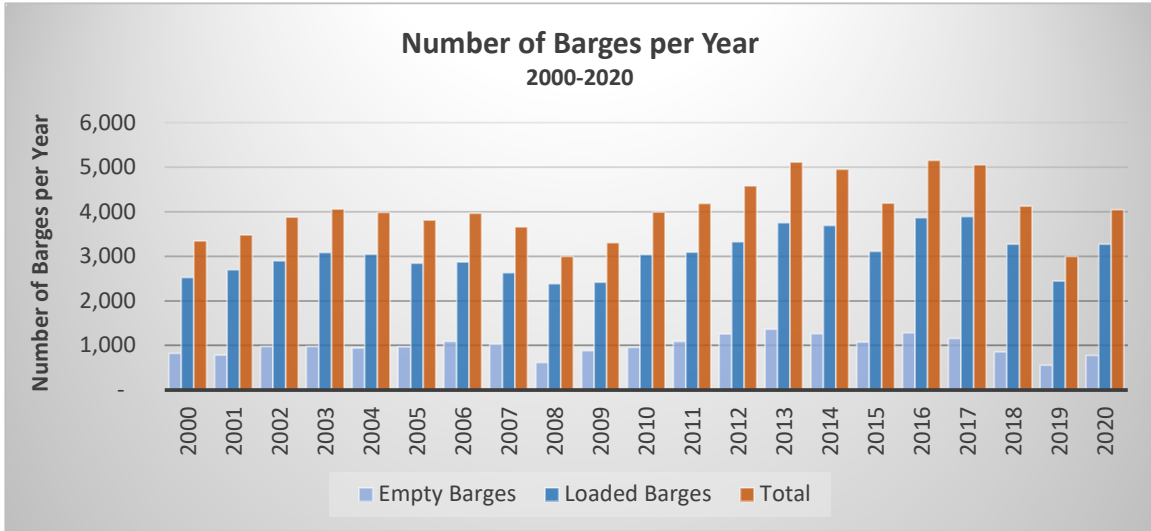
**Figure 5.3-7 Liquid and Dry Cargo Commodity Tonnages Between 1999 and 2020**

### 5.3.2 Vessel Trip Data

The vessel type classification used by USACE in their lock performance monitoring database includes the following vessels and conditions:

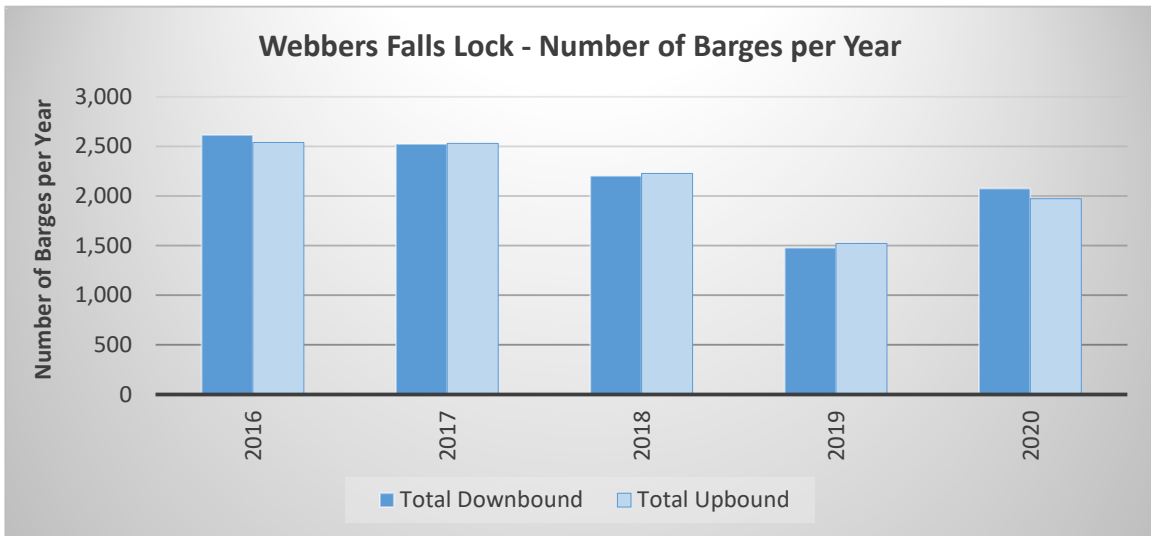
- Barges Empty (#)
- Barges Loaded (#)
- Commercial Vessels (#)
- Commercial Flotillas (#)
- Commercial Lockages/Cuts (#)
- Non-Vessel Lockages (#)
- Non-Commercial Vessels (#)
- Non-Commercial Flotillas (#)
- Non-Commercial Lockages/Cuts (#)
- Percent Vessels Delayed (%)
- Recreational Vessels (#)
- Recreational Lockages (#)
- Total Vessels (#)
- Total Lockages/Cuts (#)

The data recorded includes information on the number of barge tows and barges per tow and loading condition but does not differentiate between the type of barges. Figure 5.3-8 shows the number of empty, loaded and total barges during the period of time from 2000 through 2020, indicating a general increase in the number of barges in the period of time from 2010 and 2020 relative to the previous time period.



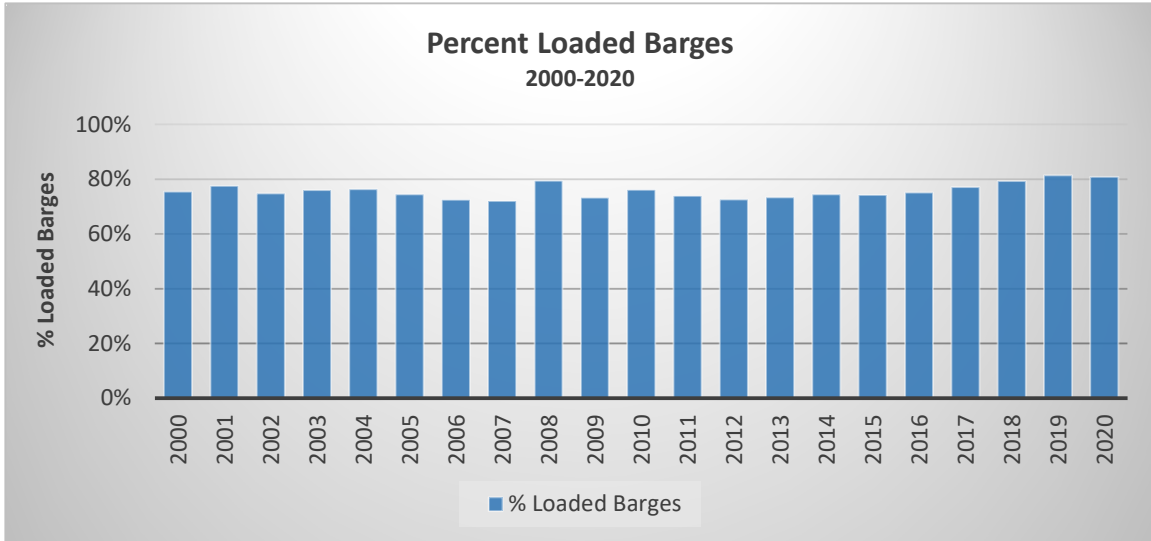
**Figure 5.3-8 Number of Barges (Empty, Loaded and Total) Going Through the Webbers Falls Lock**

Figure 5.3-9 separates the yearly number of barge trips by direction of traffic for the years 2016 through 2020. It shows that the distribution of total barge trips per direction of traffic is fairly uniform.

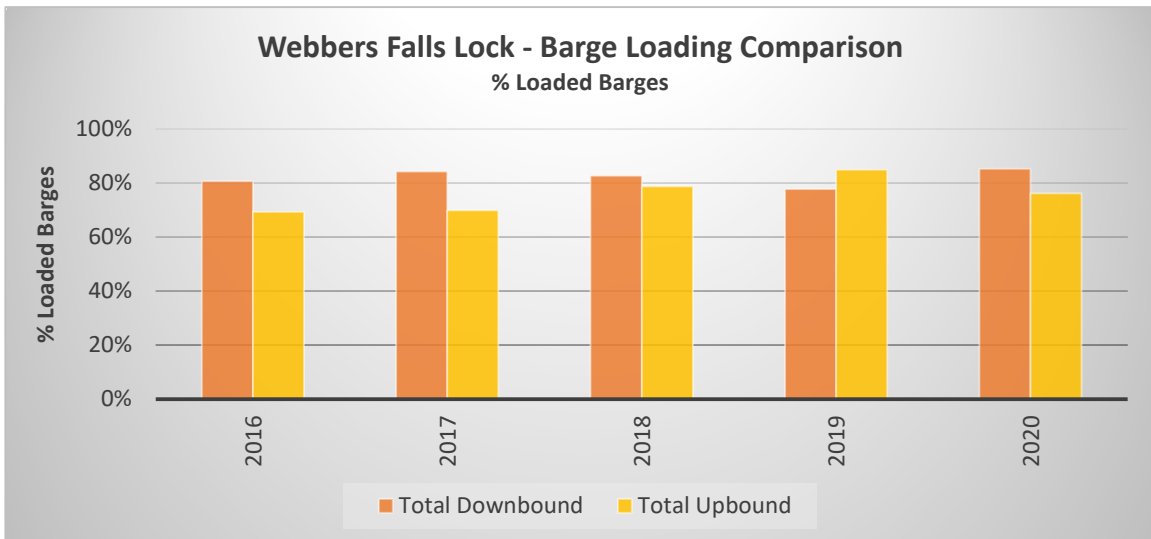


**Figure 5.3-9 Number of Barges per Year Going Through the Webbers Falls Lock Separated by Direction of Traffic**

The percent of loaded barges has remained relatively constant and around 75%, as shown in Figure 5.3-10. Figure 5.3-11 shows the percent of loaded barges separated by direction of traffic for the years 2016 through 2020.

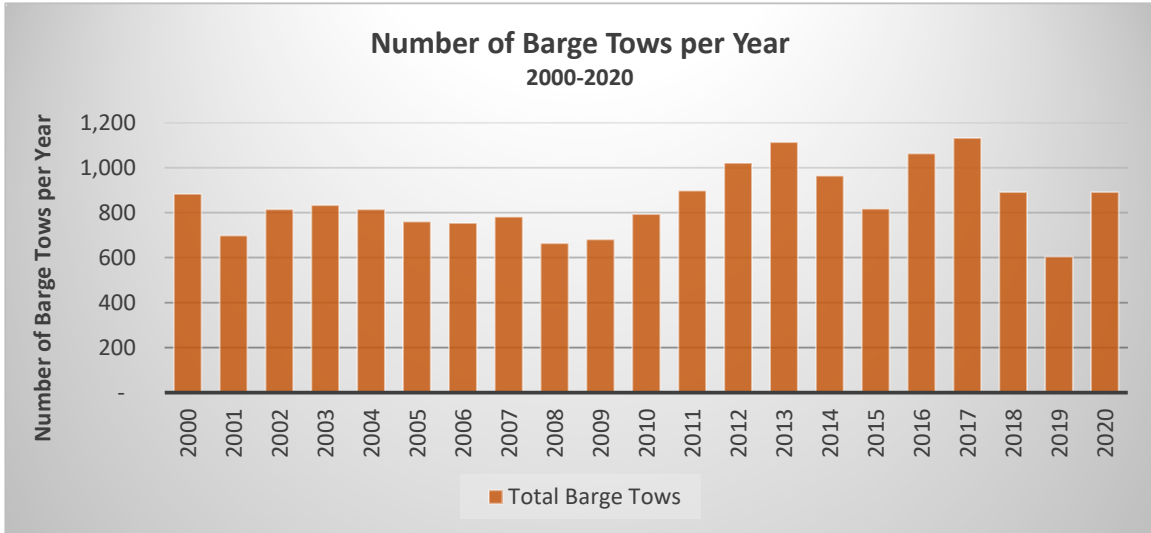


**Figure 5.3-10 Percent of Loaded Barges**



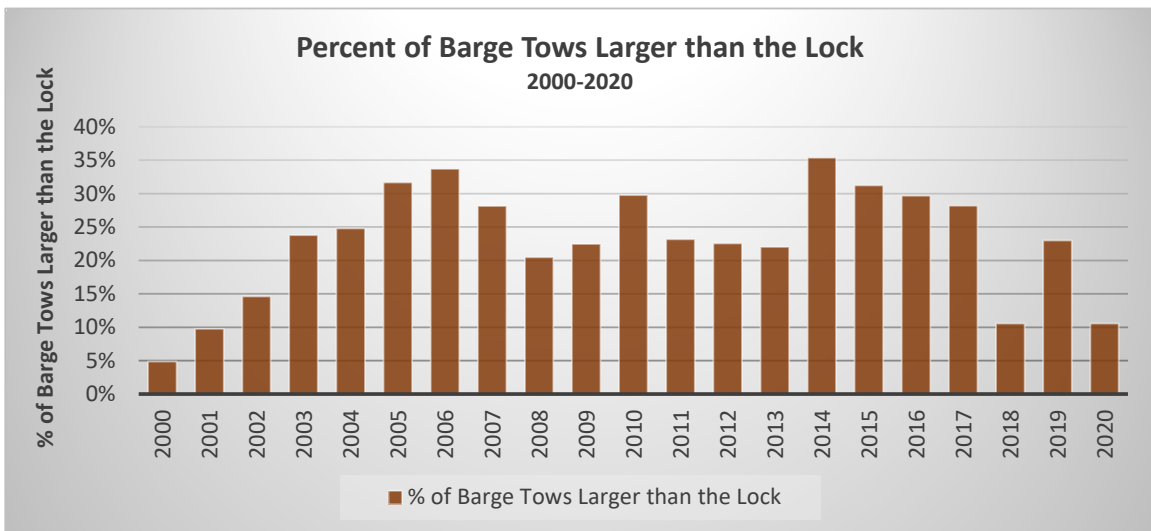
**Figure 5.3-11 Percent of Loaded Barges Separated by Direction of Traffic**

Figure 5.3-12 shows the changes in the number of barge tows per year that went through the Webbers Falls Lock between 2000 and 2020. It indicates that the use of 1,000 annual barge tow passages would be a reasonable present time estimate.



**Figure 5.3-12 Total Number of Barge Tows per Year**

A comparison between the number of barge tows and the number of commercial lockages shows that the number of commercial lockages are larger than the number of barge tows, which confirms that a number of the barge tows required more than one lockage. This is an important aspect because it provides information on the tow sizes on MKARNS. Figure 5.3-13 shows that the likely number of barge tows that were larger than the lock and required more than one lockage between 2000 and 2020 was as high as 30%. The size of the lock limits the number of dry care barges that can fit in to 9, which suggests that as many as 30% of the barge tows had more than 9 barges per tow.

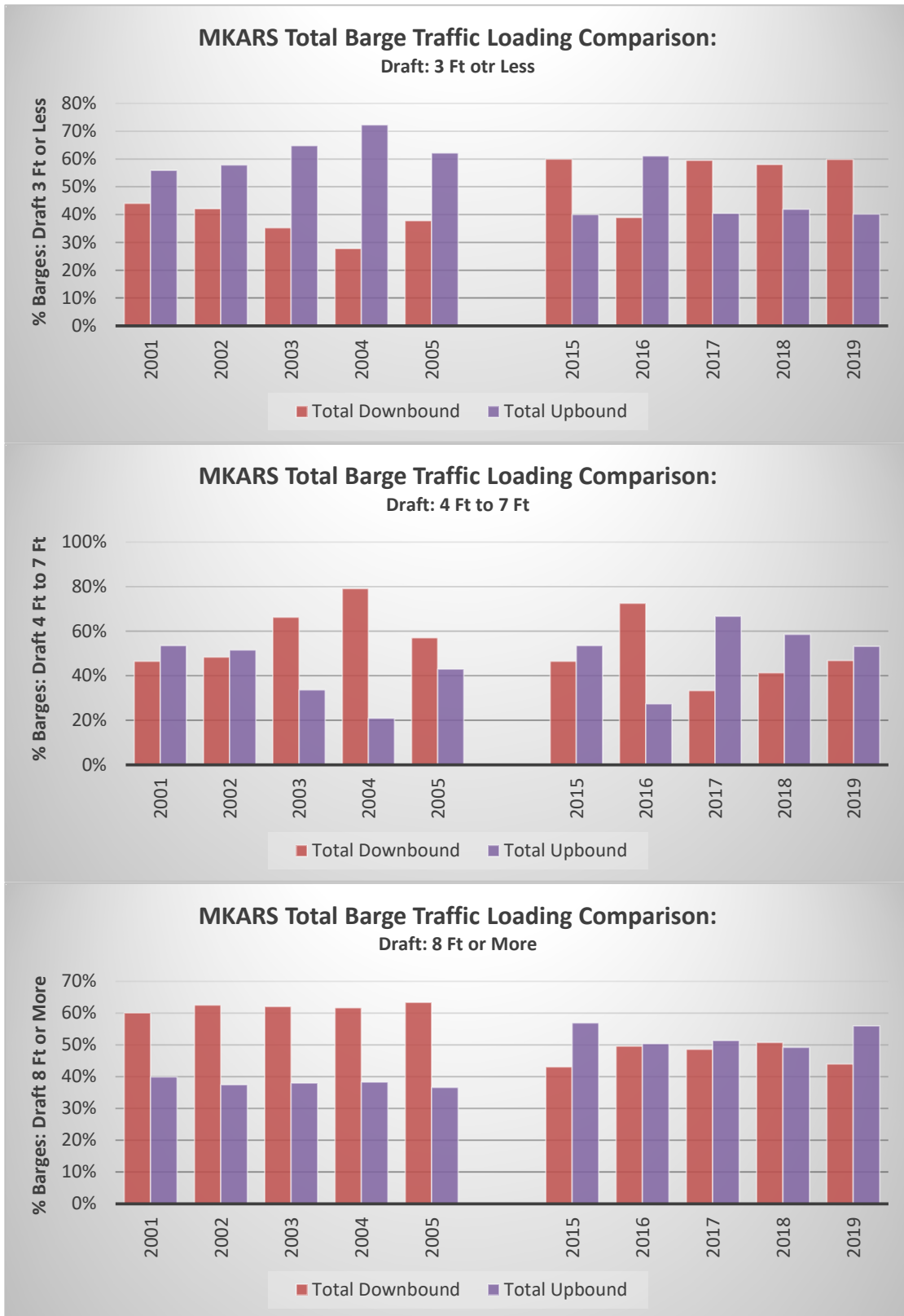


**Figure 5.3-13 Percent Barge Tows Larger than the Webbers Falls Lock Chamber**

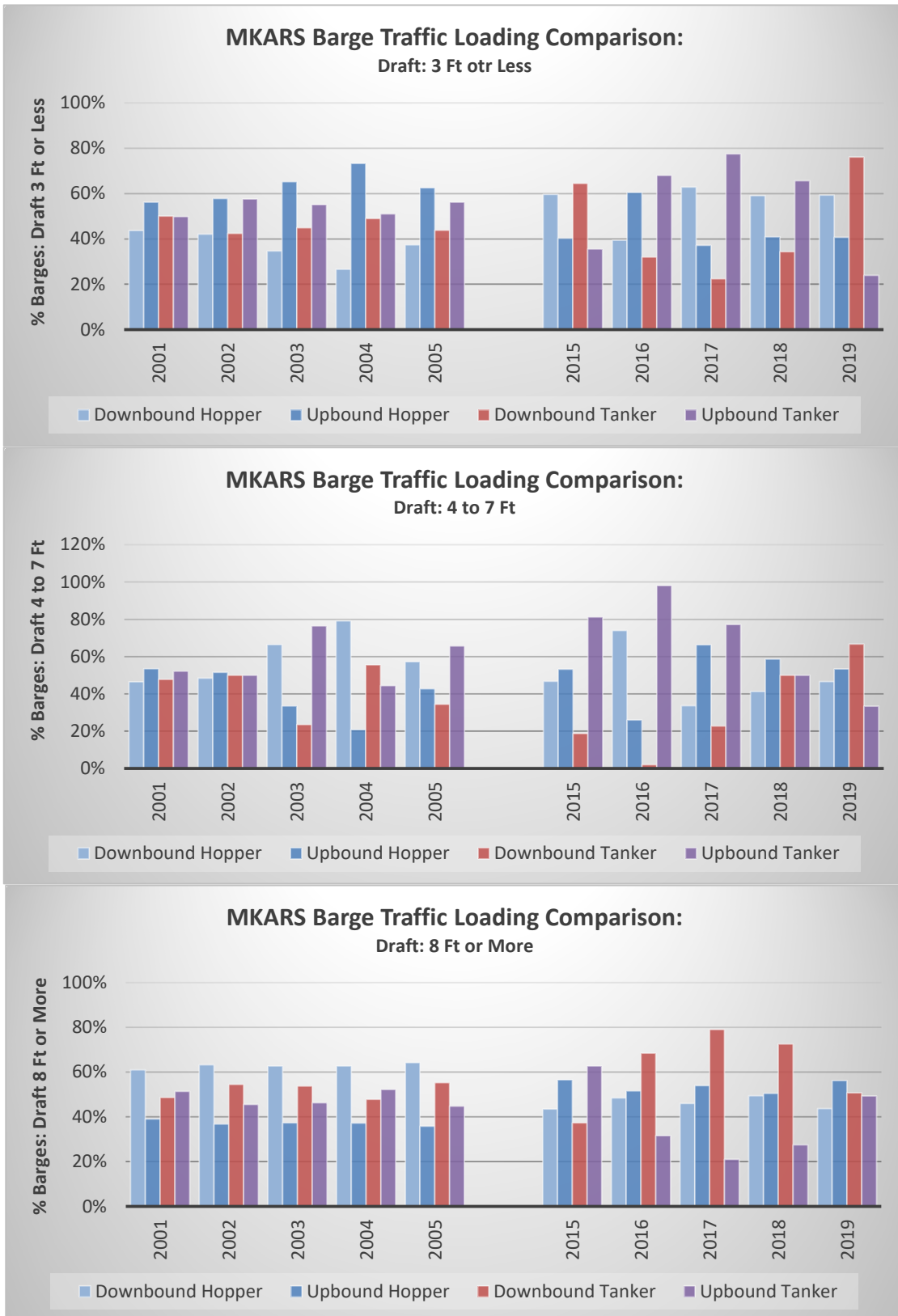
### ***5.3.3 Vessel Draft Data***

Updated historical data on the actual draft of barges was obtained from the U.S. Army Corps of Engineers Waterborne Commerce of the United States (WCUS) publications. For comparison purposes barge draft distributions were evaluated for the following time periods: 2001 to 2005 and 2015 to 2019.

Figures 5.3-14 and 5.3-15 show the percent of barges with drafts in the following categories: 3 Ft or Less, 4 Ft to 7 Ft, and 8 Ft or More for the Clellan-Kerr Arkansas River Navigation System. Figure 5.3-14 separates the data by direction of traffic and Figure 5.3-15 further separates the data by barge type. There have been changes in the distribution of barge drafts between the two time periods but without much consistency except for the trend of a more balanced distribution between the loaded barge category of 8 Ft or More of the upbound and downbound barges shown in Figure 5.3-14.



**Figure 5.3-14: Historical Comparisons of Barges Draft Distributions per Direction of Traffic**



**Figure 5.3-14: Historical Comparisons of Barges Draft Distributions per Direction of Traffic and Barge Type**

## 5.4 Present Traffic Data

### 5.4.1 General

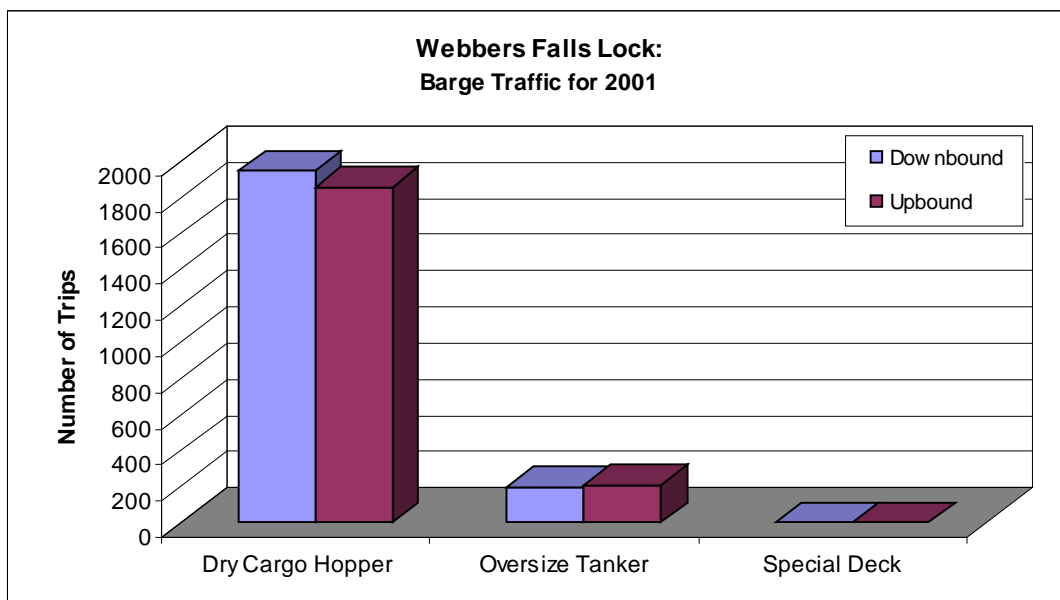
Most of the information on the present vessel traffic passing through the bridge was generated from the results of analyses conducted by the Lock Performance Monitoring System (LPMS) and by the Waterborne Commerce Statistics Center (WCSC). Additional information on the vessel characteristics was obtained from interviews with port and lock and dam personnel. The barge tow characteristics data generated from the LPMS data analysis included number of barges by type, loading condition and direction of traffic and number of barge tows by type, number of barges per tow and direction of traffic.

### 5.4.2 Barge and Tow Type Distributions

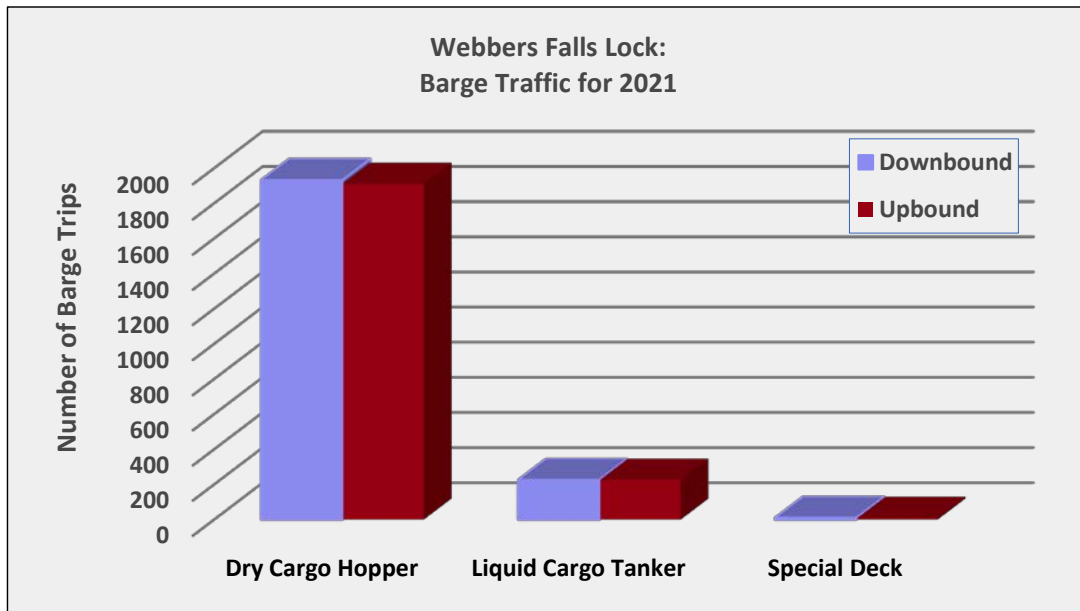
The barge categories used to analyze the data are:

|                              |                             |
|------------------------------|-----------------------------|
| Dry Cargo/Standard Hopper    | breadth < 42 feet           |
| Liquid Cargo/Oversize Tanker | 42 feet ≤ breadth ≤ 53 feet |
| Other/Special Deck           | breadth > 53 feet           |

The barge type distribution determined for the Webbers Falls Lock in the previous study is illustrated in Figure 5.4-1. The majority of barges are hopper barges, and there were no records of large special deck barge passages. Figure 5.4-2 includes the barge type distribution separated by direction of traffic based on the current traffic using 2021 as a representative year. It shows that there have not been any marked changes in the barge distribution by type and direction of traffic.

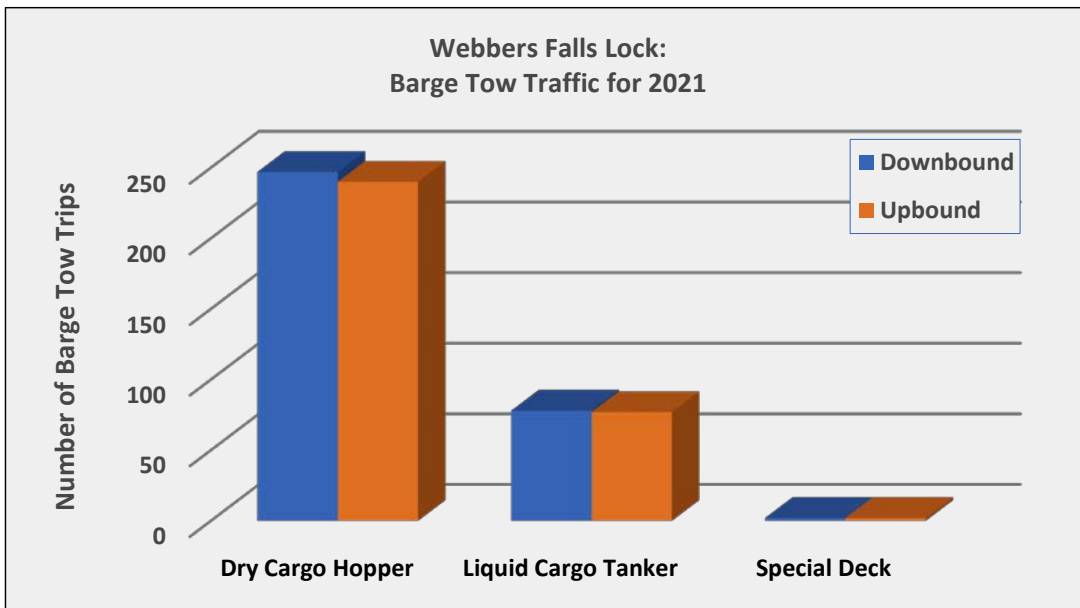


**Figure 5.4-1: Barge Type Distribution at Webbers Falls Lock from Previous Study**



**Figure 5.4-2: Barge Type Distribution at Webbers Falls Lock in 2021**

The barge tow distribution separated by type and direction of traffic based on the 2021 traffic is included in Figure 5.4-3.

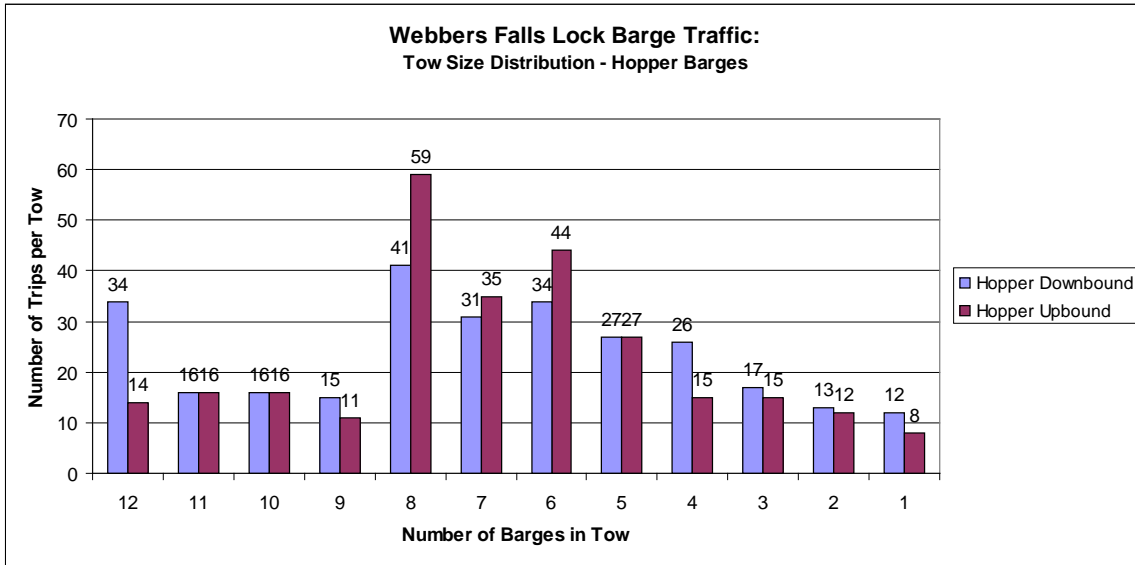


**Figure 5.4-3: Barge Tow Type Distribution at Webbers Falls Lock in 2021**

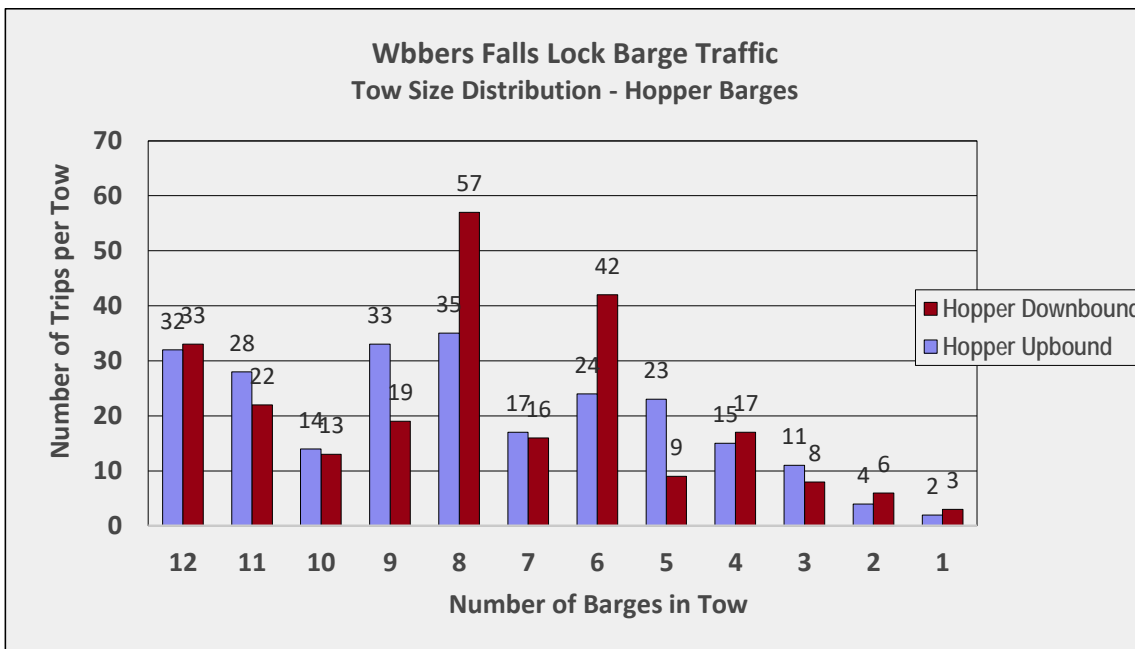
**5.4.3 Tow Size Distributions**

Figure 5.4-4 shows the tow size distribution for the hopper barge tows in each direction of traffic as determined in the previous study. The previous study found that the

hopper barge tows range in size from one to twelve barges per tow, with a six to eight barge tows being the most common. An updated plot of the tow size distribution for the hopper barge tows that reflects the present traffic is included in Figure 5.4-5. A comparison between the previous and the current data seems to indicate a trend towards larger hopper barge tows in the range of 8 to 12 barges per tow.

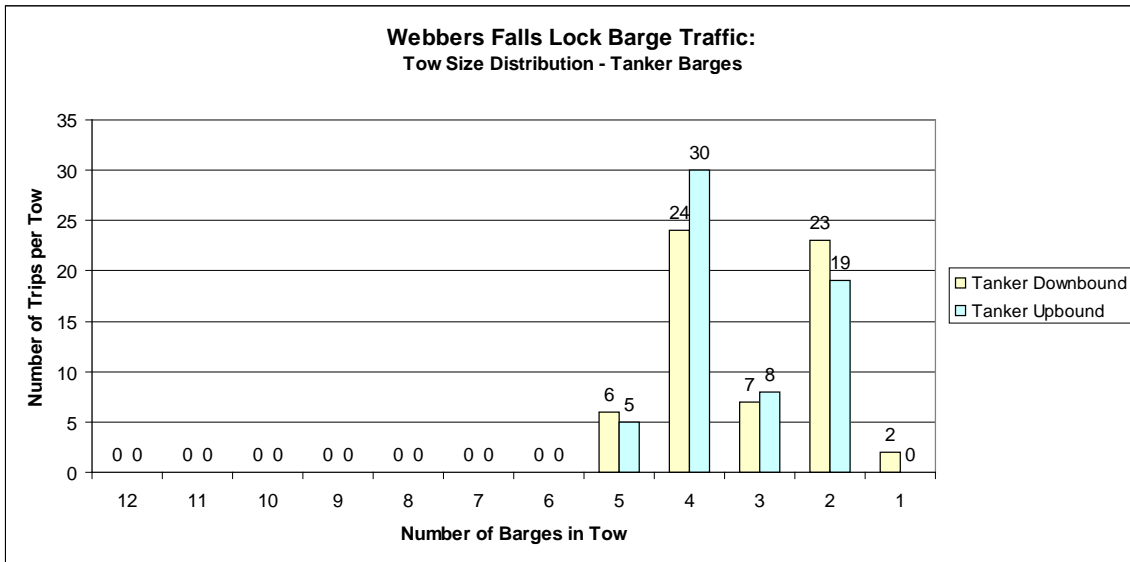


**Figure 5.4-4: Tow Size Distribution for Hopper Barge Tows at Webbers Falls Lock for 2001**

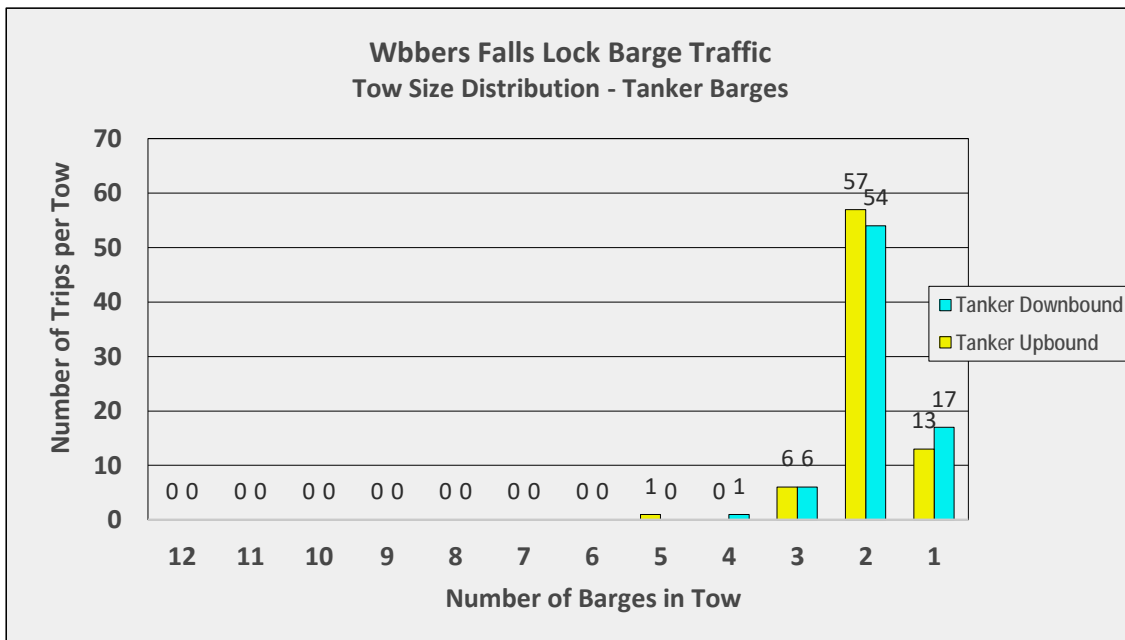


**Figure 5.4-5: Tow Size Distribution for Hopper Barge Tows at Webbers Falls Lock for 2021**

Figure 5.4-6 shows the tow size distribution for the tanker barge tows as determined in the previous study. The previous study found that the tanker barge tows range in size from one to five barges per tow, with a two or four barge tows being the most common. An updated plot of the tow size distribution for the tanker barge tows that reflects the present traffic is included in Figure 5.4-5. A comparison between the previous and the current data seems to indicate a trend towards fewer barges per tanker barge tows, mainly in the range of 1 to 3 barges per tow.



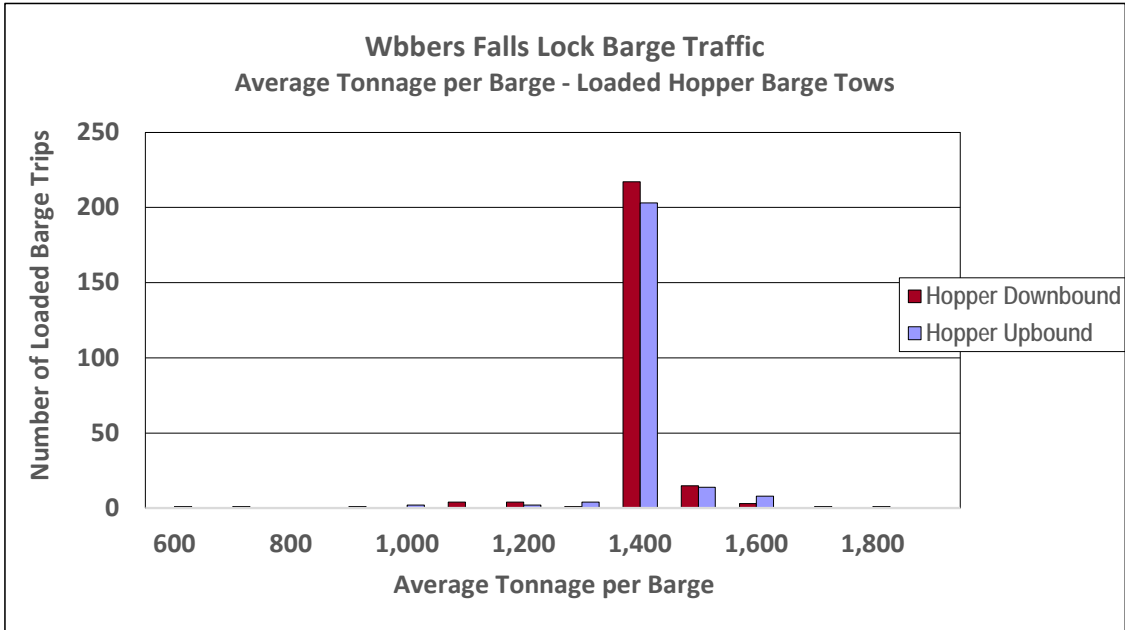
**Figure 5.4-6: Tow Size Distribution for Tanker Barge Tows at Webbers Falls Lock for 2001**



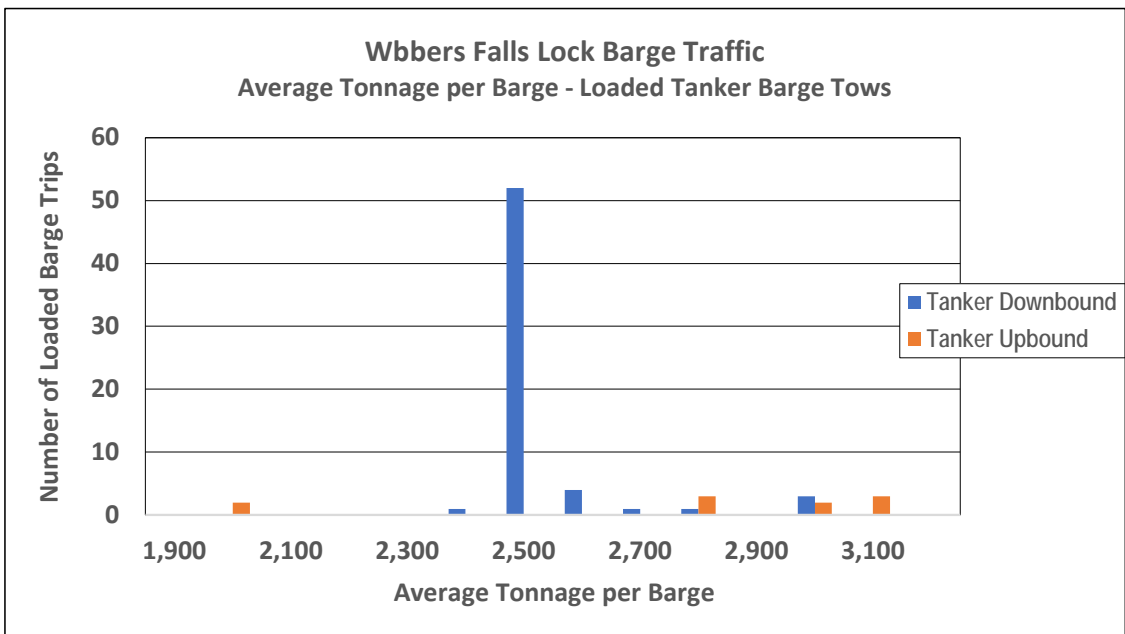
**Figure 5.4-7: Tow Size Distribution for Tanker Barge Tows at Webbers Falls Lock for 2021**

**5.4.4 Barge Loading Conditions**

Information on the tonnage carried by barges in loaded hopper and tanker barge tows is included in Figures 5.4-8 and 5.4-9 for the year 2021.



**Figure 5.4-8: Average Tonnage per Barge in Loaded Hopper Barge Tows at Webbers Falls Lock for 2021**



**Figure 5.4-9: Average Tonnage per Barge in Loaded Tanker Barge Tows at Webbers Falls Lock for 2021**

Figure 5.4-8 shows that the loading of the hopper barge tows is relatively constant and around 1,400 tons, which is about 500 tons less than what a standard hopper barge can carry.

The loading of tanker barges in the loaded tanker barge tows included in Figure 5.4-9 shows some variations in the range of 2,000 to 3,100 tons, with a definite peak at 2,500 tons in the downbound direction. This loading is about 1,200 tons less than what an oversize tank barge can carry.

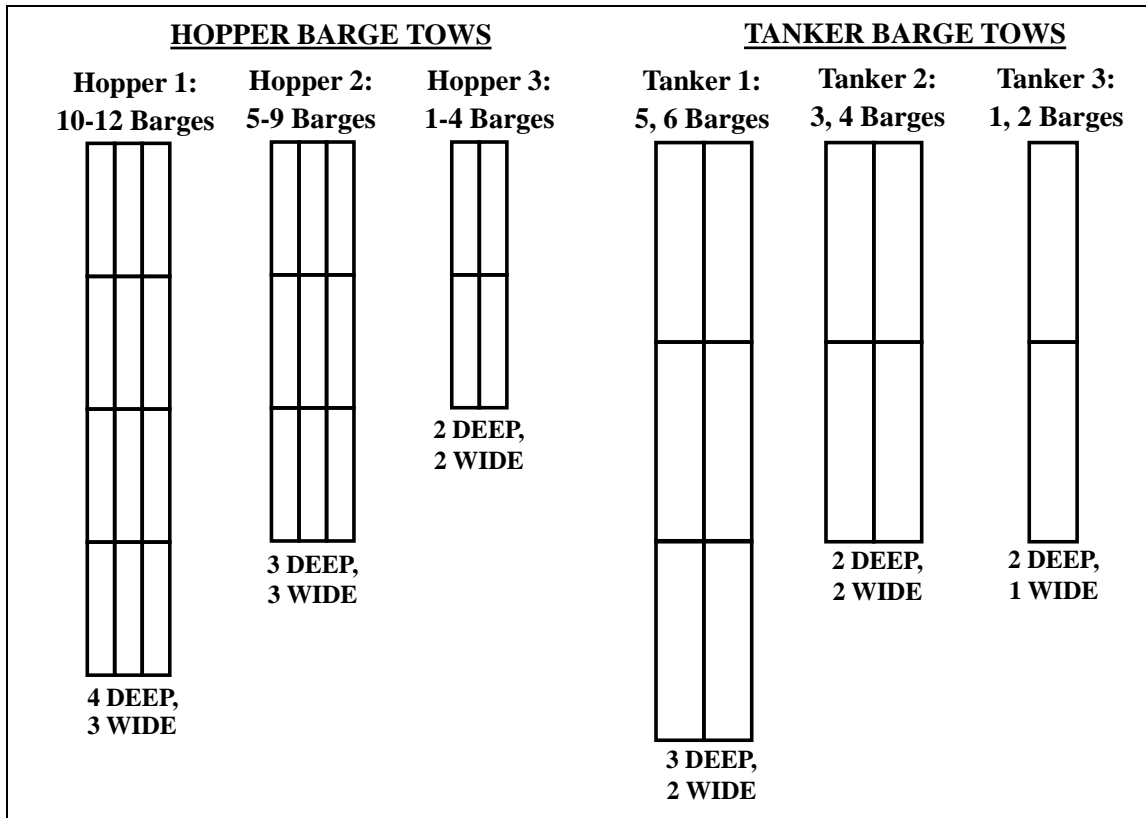
## 5.5 Projection of Future Traffic

The previous study projection was that the increasing trend in the volume of traffic between 1980 and 2001 will also continue during the next 20 years, and that the type and makeup of traffic will remain relatively constant. Since from 1980 to 2001 the total tonnage has increased by 32%, a 30% increase in the number of barge tow trips was also projected for the year 2020.

The volume of traffic in the peak years of 2003 and 2017 included in Figure 5.3-3 shows an increase of about 20% between these years, which is about 30% when extrapolated over a 20-year period. This is consistent with the projection made in the previous study. Although the traffic has dropped in recent years, the expectation is that overall, it will continue to increase and using the mid-life of the new bridge as a target for a future traffic projection year, the use of a 50% increase in the current traffic through 2060 is recommended.

## 5.6 Evaluation Vessel Groups

The vessel traffic data update did not find differences in the traffic make-up that would require changes in the previously established vessel groups shown in Figure 5.6-1. These groups include the following categories: Hopper 1, Hopper 2, Hopper 3, Tanker 1, Tanker 2, and Tanker 3. Figure 5.6-1 illustrates the tow size for each of the barge groups and the number of barges per tow that they represent.



**Figure 5.6-1: Evaluation Vessel Groups**

The tow characteristics used in the previous study are shown in Table 5.6-1. They are based on the typical barge characteristics listed in the AASHTO Guide Specification for each barge type and are applicable to the present study as well. A 90-foot-long towboat with an estimated displacement of 300 tonnes was selected.

**Table 5.6-1: Representative Barge Tows**

| Barge    | Length (Feet) | Width (Feet) | Loaded Draft (Feet) | Light Draft (Feet) | Max. Capacity (tons) | Length of Towboat (Feet) |
|----------|---------------|--------------|---------------------|--------------------|----------------------|--------------------------|
| Hopper 1 | 4 x 195       | 3 x 35       | 9                   | 2                  | 20,400               | 90                       |
| Hopper 2 | 3 x 195       | 3 x 35       | 9                   | 2                  | 15,300               | 90                       |
| Hopper 3 | 2 x 195       | 3 x 35       | 9                   | 2                  | 6,800                | 90                       |
| Tanker 1 | 3 x 290       | 2 x 53       | 9                   | 2                  | 18,500               | 90                       |
| Tanker 2 | 2 x 290       | 2 x 53       | 9                   | 2                  | 14,800               | 90                       |
| Tanker 3 | 2 x 290       | 1 x 53       | 9                   | 2                  | 7,400                | 90                       |

Table 5.6-2 shows the evaluation vessel group trip distributions determined in the previous study. It includes the number of trips assigned to each tow type and size considered. The updated number of trips based on the present traffic for each evaluation vessel group is shown in Table 5.6-3. Where the number of vessel trips based on the current traffic data was less than the previous number of trips the previous number of trips was considered and used as appropriate.

**Table 5.6-2: Evaluation Vessel Group Trip Distribution (Previous Study Traffic)**

| Barge Tow | Total Trips |         | Loaded    |         | Empty     |         |
|-----------|-------------|---------|-----------|---------|-----------|---------|
|           | Downbound   | Upbound | Downbound | Upbound | Downbound | Upbound |
| Hopper 1  | 66          | 46      | 45        | 39      | 21        | 7       |
| Hopper 2  | 148         | 176     | 101       | 150     | 47        | 26      |
| Hopper 3  | 68          | 50      | 46        | 43      | 22        | 7       |
| Tanker 1  | 6           | 5       | 5         | 1       | 1         | 4       |
| Tanker 2  | 31          | 38      | 27        | 10      | 4         | 28      |
| Tanker 3  | 25          | 19      | 22        | 5       | 3         | 14      |

**Table 5.6-2: Evaluation Vessel Group Trip Distribution (Present Traffic)**

| Barge Tow | Total Trips |         | Loaded    |         | Empty     |         |
|-----------|-------------|---------|-----------|---------|-----------|---------|
|           | Downbound   | Upbound | Downbound | Upbound | Downbound | Upbound |
| Hopper 1  | 95          | 80      | 75        | 70      | 20        | 10      |
| Hopper 2  | 180         | 175     | 130       | 150     | 50        | 25      |
| Hopper 3  | 65          | 55      | 45        | 45      | 20        | 10      |
| Tanker 1  | 15          | 15      | 10        | 5       | 5         | 10      |
| Tanker 2  | 35          | 40      | 30        | 10      | 5         | 30      |
| Tanker 3  | 75          | 70      | 70        | 55      | 5         | 15      |

## 5.7 Navigation Conditions and Regulations

The vessel navigation through the bridge could be affected by the turns in the channel on both sides of the bridge and the skew of the bridge relative to the channel, but overall, the I-40 Bridge is not a difficult navigation site. The 2002 vessel collision was caused by the towboat captain becoming incapacitated and was not related to the site conditions. The navigation on the McClellan-Kerr Arkansas River Navigation System is well managed and there are regulations in place to ensure safety.

The navigation regulations on the McClellan-Kerr Arkansas River Navigation System are included in 33 Code of Federal Regulations 162.9 *White River, Arkansas Post Canal, Arkansas River, and Verdigris River between Mississippi River, Ark., and Catoosa, Okla.; use, administration, and navigation*. The regulations apply to the waterways, bridges, wharves and other structures listed in this section, and to vessels and rafts. The following regulations in 33 CFR 162.9 are specific to vessels passing through a bridge:

- (3) (ii) When approaching and passing through a bridge, all vessels and rafts, regardless of size, shall control their speed so as to insure that no damage will be done to the bridge or its fenders.

- (3) (iii) Within the last mile of approach to unattended, normally open automatic, movable span bridge, the factor of river flow velocity, of vessel (and tow) velocity, and of vessel power and crew capability are never to be permitted to result in a condition whereby the movement of vessel (and tow) cannot be completely halted or reversed within a 3-minute period.

## 6. MARINE TERMINALS, WHARVES, AND DOCKS

### 6.1 General

Facilities located in the vicinity of the bridge can affect vessel navigation by increasing the local traffic density and decreasing the width of the river available for navigation. Vessel operations at these facilities may interfere with the main river traffic increasing the likelihood of incidents. In addition, vessels can break loose from their moorings and drift towards bridge crossing and other facilities.

### 6.2 Facilities Near the I-40 Bridge Crossing

The closest facilities to the bridge site include Jeffrey Sand Co Sand Plant No 5 Dock and Consolidated Grain and Barge Co Webbers Falls Dock (see Figure 6.2-1). They are both located upstream of the bridge and downstream of the Webbers Falls Lock and Dam.



Figure 6.2-1: Location of Facilities Near the Bridge Site

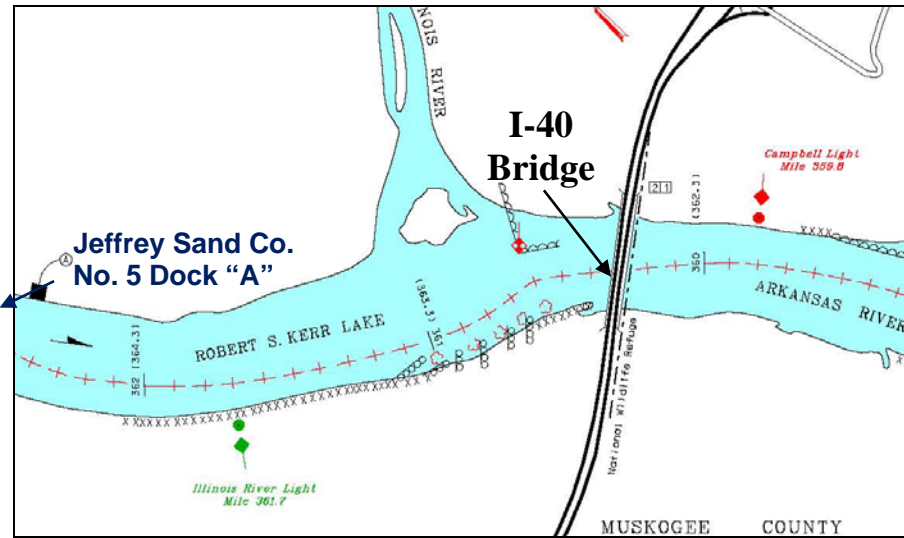
Included below is information on each facility.

#### **A. Jeffrey Sand Co Sand Plant No 5 Dock**

The Jeffrey Sand Co Sand Plant No 5 Dock is located at Mile 362.4, left bank, Arkansas River, Gore, approximately 0.6 mile below U.S. Highway 64 Bridge. The current owner is Jeffrey Sand Co., Inc. Phone: 501/945-4161. The commodities handled include Fertilizers, Sand, Gravel, Stone, Rock, Limestone, Soil and Dredged Material. It is not always operational. Figure 6.2-2 shows several barges using the facility in 2018 and Figure 6.2-3 includes a navigation chart showing the location of the facility relative to the bridge.



**Figure 6.2-2: View of Barges using the Jeffrey Sand Co Sand Plant No 5 Dock (Google)**



**Figure 6.1-3: Navigation Chart Showing the Location of the Jeffrey Sand Co Sand Plant No 5 Dock Relative to the Bridge the Bridge Site (USACE)**

### **B. Consolidated Grain and Barge Co Webbers Falls Dock**

The Consolidated Grain and Barge Co Webbers Falls Dock is located at Mile 363.2, right bank, Arkansas River, Webbers Falls, above Oklahoma State Highway 64 Bridge. The current owner and operator is Consolidated Grain and Barge Co. Phone: 918/464-2296. The main commodities received include fertilizers and feed ingredients and the shipments are grain. The facility has a grain elevator consisting of four steel tanks. Its slip is 120 feet wide, with capacity for mooring six barges. An aerial view of the facility is included in Figure 6.2-4



**Figure 6.2-4: View of the Consolidated Grain and Barge Co Webbers Falls Dock**

## **7. VESSEL COLLISION ANALYSIS**

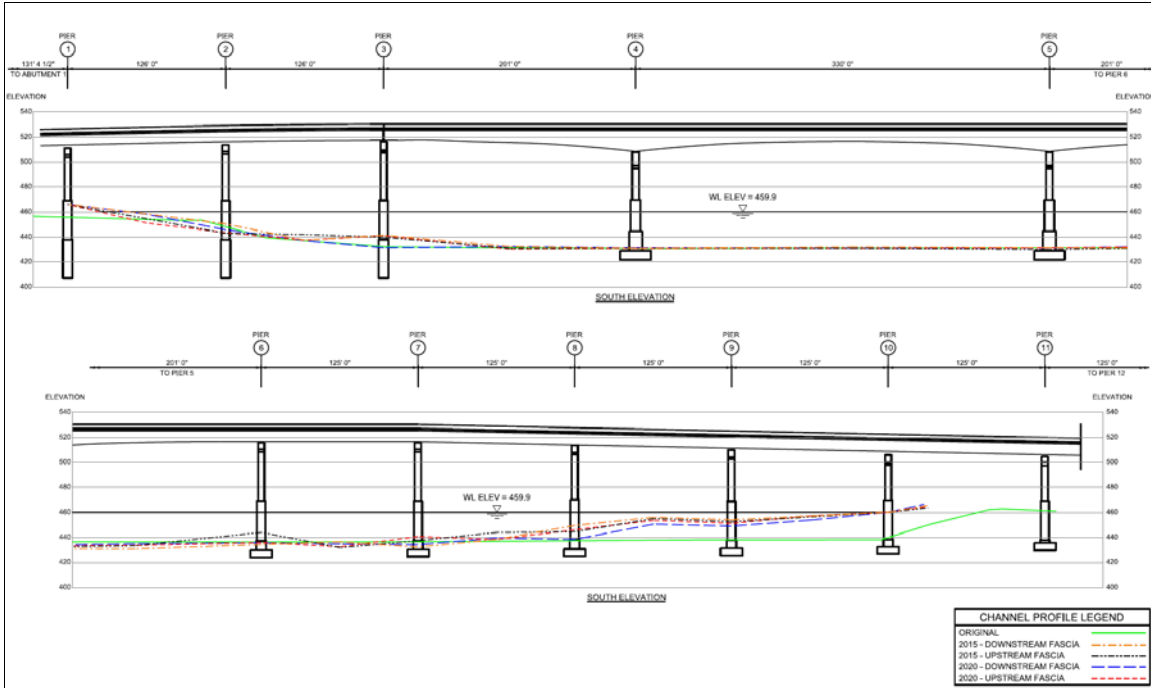
### **7.1 Methodology**

The bridge substructure vessel collision analysis procedure follows AASHTO LRFD and Method II of the “AASHTO Guide Specifications and Commentary for Vessel Collision Design of Highway Bridges.” Method II is a probability based, risk-based analysis procedure. An idealized mathematical model describing the bridge and the vessel traffic transiting through the bridge is used to estimate the probability of substructure collapse. Vessel, bridge, and waterway characteristics data are used to determine the probability of vessel aberrancy, geometric probability, and probability of collapse. These probabilities lead to the computation of annual frequencies of collapse, which are related to acceptable values for the bridge classification considered. Substructure risk evaluations are made for both the present traffic and a future traffic projection year so that changes in the projection year and the future traffic growth can be readily assessed.

### **7.2 Evaluation Vessels and Vessel Access to Bridge Piers**

Several representative barge tow categories are used as evaluation vessel groups. They include three hopper and three tanker barge tow categories (see Section 5.6). Geometric probabilities and probabilities of collapse are calculated for each barge tow category for both the upstream and the downstream directions. The direction of traffic is separated in analysis because of the different channel, barge loading and pier access conditions.

The piers exposed to vessel access during high water events include piers 2 through 12. The rest of the piers are on land, and they are not likely to be hit by barges. Average riverbed elevations are based on information obtained from the previous study and from the more recent Oklahoma Department of Transportation I-40 Bridge Underwater Inspection Report performed by CONSOR Engineers, LLC, dated July 2020 (see Figure 7.2-1).



**Figure 7.2-1: Bridge Elevation and Riverbed Data (CONSOR 2020)**

For each pier, the number of trips considered is reduced based on the access of a given evaluation vessel group to the pier. Two types of vessel traffic reduction factors are used for each direction of traffic (upstream or downstream) and direction of impact (longitudinal or transverse to channel). They include water depth access factors and pier protection access factors. The water depth access factors take into account the actual vessel draft in relation to the water depth, and the pier protection access factors take into account the existence of pier protection or other barriers that limit vessel access to the piers.

### 7.3 Probability of Aberrancy

#### 7.3.1 General

The probability of aberrancy (PA) is a value related to the statistical probability that a vessel will stray off course and threaten the bridge. Vessel aberrancy is usually a result of pilot error, adverse environmental conditions, or mechanical failure. The AASHTO Guide (AASHTO 2009) recommends two methods of determining PA. As stated in Section 4.8.3.2, “the most accurate method of determining PA for a particular bridge site is based on historical data on vessel collisions, rammings, and groundings in the waterway, and the number of vessels transiting the waterway during the period of accident reporting.” In lieu of this method, PA can be estimated based on the AASHTO Guide, formula 4.8.3.2-1. Review of the updated historical vessel incidents and accident data found that the PA’s that were determined in the previous study based on both the AASHTO formula and the historical accident data methods remain applicable.

### ***7.3.2 Probability of Aberrancy Based on AASHTO Formula***

According to the AASHTO Guide formula, the probability of aberrancy is determined by taking a base rate probability (BR) and multiplying it by a series of correction factors that account for bridge location ( $R_B$ ), water current ( $R_C$ ), cross-currents ( $R_{XC}$ ), and vessel traffic density ( $R_D$ ). Thus, PA is calculated as follows:

$$PA = (BR)(R_B)(R_C)(R_{XC})(R_D)$$

The aberrancy base rate, BR, recommended for barge tows is  $1.2 \times 10^{-4}$ , and the guidelines for calculating the correction factors are given in the AASHTO Guide, Section 4.8.3.2.

The I-40 Bridge is located on the Arkansas River section of the MCKARNS, at river mile 360.3. There are bends in the channel on both the upstream and downstream sides of the bridge. A  $31^\circ$  bend is located approximately 1,375 feet on the upstream side of the bridge, and a  $24^\circ$  bend is located approximately 3,240 feet on the downstream side of the bridge. The river flow is slightly skewed relative to the bridge. Although the current flow is usually controlled, the current velocity can vary from very low to as high as 3 knots (5 ft/sec) during a high-water event. A yearly mean current velocity of 1.5 knots (2.5 ft/sec) is assumed for the downstream direction at this location (see AASHTO Guide, Section 3.7), and a current velocity of 2.5 knots (4.2 ft/sec) is assumed to be representative of the current component parallel to an aberrant vessel path (see AASHTO Guide, Section 4.8.3.2). No cross currents were observed at the site during the previous study, and a cross-current velocity of 0 knots was used for both directions. Since barge tows rarely meet or pass each other under the bridge, a low vessel traffic density factor is used in the analysis.

The above information on the local influencing conditions is used to calculate the series of correction factors that account for bridge location ( $R_B$ ), water current ( $R_C$ ), cross-currents ( $R_{XC}$ ), and vessel traffic density ( $R_D$ ).

### ***7.3.3 Probability of Aberrancy Based on Historical Accident Data***

Historical accident data was obtained from a special search and analysis of vessel incidents involving collisions, allisions, loss of vessel control and groundings in the Verdigris and Arkansas rivers from 1991 through 2001, as discussed in the previous study. This analysis was updated based on vessel incidents on the Verdigris and Arkansas rivers from 1/2002 through 7/2015 (see Section 3.2).

Because of their distinct characteristics, the data was analyzed separately for the Oklahoma and Arkansas portions of the waterway.

The approach used to estimate the probability of aberrancy assumed the existence of a general, constant probability that a vessel will stray off course because of human errors and/or mechanical conditions under favorable conditions. This probability is

referred to as the causation probability (A) in Larsen (1983), the basic aberrance probability (BAP) in INCOM (2001) and the base rate probability (BR) in AASHTO (2009). When combined with the probability of local influencing factors, this basic probability can be modified to reflect the local probability of aberrancy.

In the previous study the base rate of the probability of aberrancy was determined by summing up the individual base rate,  $BR_{\text{accident type}}$ , for each of the incident types, using the following expressions:

$$BR = \sum BR_{\text{accident type}}$$

$$BR_{\text{accident type}} = \frac{N_{\text{incidents}}}{N_{\text{years}} L_{\text{waterway}} T} \frac{L_{\text{vicinity}}}{F_{PG}}$$

where

|                             |  |
|-----------------------------|--|
| $BR_{\text{accident type}}$ | = Base rate of probability of aberrancy for each type of incident  |
| $N_{\text{incidents}}$      | = Number of recorded incidents by type in a known period   |
| $N_{\text{years}}$          | = Number of years of record for incidents  |
| $L_{\text{waterway}}$       | = Total length of waterway over which incidents were recorded  |
| $T$                         | = Average number of trips made by the vessels types under consideration in the waterway annually   |
| $L_{\text{vicinity}}$       | = Influencing length of waterway to be considered as within the vicinity of the bridge   |
| $F_{PG}$                    | = Adjustment factor due to the geometric probability of a collision between an aberrant vessel and a bridge pier or span or another vessel |

Since the reported information spanned from 1991 to 2001,  $N_{\text{years}}$  equals 11.  $L_{\text{waterway}}$  is 136.2 miles for the Oklahoma portion and 308.6 miles for the Arkansas portion.  $L_{\text{vicinity}}$  was conservatively taken as 2.0 miles for both the Oklahoma portion and the Arkansas portion. The  $L_{\text{vicinity}}$  values used in INCOM (2001) range from 1 to 1.3 miles.

The average number of trips made by the vessel types under consideration in the waterway annually,  $T$ , was obtained from detailed database files that contain the U.S. Army Corps of Engineers Monthly Summary Statistics collected within the Lock Performance Monitoring System. The only vessels considered were the barge tows. The locks used to obtain the barge tow trip data include the Newt Graham Lock, the James W. Trimble Lock, and the Norrell Lock. For the Oklahoma portion, the annual number of barge tows was averaged using tow data from the Newt Graham Lock and the James W. Trimble Lock statistics for 1995 and 1999. For the Arkansas portion, the annual number of barge tows was averaged using tow data from the James W. Trimble Lock and the Norrell Lock statistics for 1995 and 1999. Thus,  $T_{\text{Oklahoma}}$  was estimated as 784 barge tows annually, and  $T_{\text{Arkansas}}$  as 1,225 barge tows annually.

The number of vessel trips that is often used to estimate the frequency of incidents is based on the U.S. Army Corps of Engineers Waterborne Commerce Statistics data. This data includes the number of individual trips within a waterway or a section of a waterway, which is generally larger than the actual number of vessel passages at a given location. The vessel trip data based on the Lock Performance Monitoring System that was used is closer to the actual number of trips at a given location.

The adjustment factor due to the geometric probability,  $F_{PG}$ , varies depending on the local conditions and the accident type. As discussed in INCOM (2001), it may be assumed that, on average, one out of three loss of vessel control events can result in an allision, and one out of five loss of vessel control events can result in a collision. Subsequently, we may use  $F_{PG \text{ allisions}}$  equals 0.33,  $F_{PG \text{ collisions}}$  equals 0.2, and  $F_{PG \text{ Loss of Vessel Control}}$  equals 1. For groundings, the grounding model developed by Kristiansen (1983) was used. Based on this model, the geometric probability of grounding over a distance,  $L$ , along the waterway can be calculated as follows:

$$PG_{\text{groundings}} = 1 - \frac{2W}{\pi L}$$

where

|                          |  |
|--------------------------|--|
| $PG_{\text{groundings}}$ | = Geometric probability of grounding over a distance, $L$ , along the waterway |
| $W$                      | = Width of the waterway  |
| $L$                      | = Length of waterway considered  |

Two allisions were conservatively added to the accident period considered (1991-2001) to account for three allisions that are known to have occurred in Oklahoma between 1983 and 2004. In 1983, maintenance records for the I-40 Bridge indicate that an unknown vessel struck a channel pier. In 2002, the I-40 Bridge collapsed as the result of an allision, and one unknown allision was reported at a nearby bridge. The rate of allisions was calculated by counting 3 allisions from 1983 to 2004 (21 years) and adjusting for the study period of 11 years. This resulted in about 2 additional allisions.

The contributions of the various accident types to the historical probability of aberrancy base rates are shown in Table 7.3.3.1 for the Oklahoma portion and in Table 7.3.3.2 for the Arkansas portion of the waterway. The historical probability of aberrancy base rate was found to be  $3.8 \times 10^{-5}$  for Oklahoma and  $5.1 \times 10^{-5}$  for Arkansas. These rates are smaller than the BR value of  $1.2 \times 10^{-4}$  calculated based on the AASHTO formula by about 3.2 times for Oklahoma and 2.4 times for Arkansas. Given that the nature and frequency of incidents did not change much during the more recent time period investigated, the above noted conclusions remain applicable.

**Table 7.3.3.1: Historical Base Rate of Probability of Aberrancy for the Oklahoma Portion of the McClellan-Kerr Arkansas River Navigation System**

| Accident Type                | $N_{incidents}$ | $F_{PG}$ | $BR_{accident\ type}$                  |
|------------------------------|-----------------|----------|--|
| Allisions                    | 2               | 0.3      | $1.0 \times 10^{-5}$                   |
| Groundings                   | 8               | 0.8      | $1.7 \times 10^{-5}$                   |
| Collisions                   | 1               | 0.2      | $8.5 \times 10^{-6}$                   |
| Loss of Vessel Control       | 1               | 1.0      | $1.7 \times 10^{-6}$                   |
| $\Sigma BR_{accident\ type}$ |                 |          | <b><math>3.8 \times 10^{-5}</math></b> |

**Table 7.3.3.2: Historical Base Rate of Probability of Aberrancy for the Arkansas Portion of the McClellan-Kerr Arkansas River Navigation System**

| Accident Type                | $N_{incidents}$ | $F_{PG}$ | $BR_{accident\ type}$                  |
|------------------------------|-----------------|----------|--|
| Allisions                    | 4               | 0.3      | $5.8 \times 10^{-6}$                   |
| Groundings                   | 55              | 0.8      | $3.4 \times 10^{-5}$                   |
| Collisions                   | 1               | 0.2      | $2.4 \times 10^{-6}$                   |
| Loss of Vessel Control       | 19              | 1.0      | $9.1 \times 10^{-6}$                   |
| $\Sigma BR_{accident\ type}$ |                 |          | <b><math>5.1 \times 10^{-5}</math></b> |

To obtain the probability of aberrancy,  $PA$ , the historical base rate probability may be multiplied by a series of correction factors that account for bridge location ( $R_B$ ), water current ( $R_C$ ), cross-currents ( $R_{XC}$ ), and vessel traffic density ( $R_D$ ), in the same manner as in the AASHTO formula method. Using similar local influencing factors as described in Section 7.3.2, the barge tow probability of aberrancy was computed as  $8.0 \times 10^{-5}$  for the downstream traffic and  $5.0 \times 10^{-5}$  for the upstream traffic.

## 7.4 Geometric Probability

The geometric probability (PG) is defined as the conditional probability that a vessel will hit a bridge pier given that it has lost control (it is aberrant) in the vicinity of the bridge. The geometric probability is calculated statistically using a normal distribution for the location of the aberrant vessel across the waterway. The PG represents the area in the normal distribution within the zone of impact. One standard deviation of the distribution is assumed as the length overall (LOA) of the evaluation vessel group. The geometric probability depends on the size of the pier, the skew of the pier relative to the channel and the width of the barge tow. Wider tows have a higher likelihood of contacting part of the substructure. It also depends on the location of the shoreline relative to a given pier, which could prevent some barge tows from reaching the pier. Different geometric probabilities are calculated for each barge tow category.

## 7.5 Vessel Impact Speed and Collision Forces

The vessel collision forces were computed in the previous study using an operating speed of 12.5 ft/sec for the downstream traffic and 9.5 ft/sec for the upstream traffic. This current study found that a lower vessel speed in the range of 8 ft/sec to 11

ft/sec could be used. The operating speed reflects typical vessel transit speeds within the navigable channel limits in the vicinity of the bridge under normal environmental circumstances.

Vessel impact loads were calculated for each barge tow category for both the longitudinal and the transverse directions and for the actual loading condition, according to the current AASHTO Guide. For impacts applied in a direction parallel to the alignment of the centerline of the navigable channel, 100% of the impact force is used. For perpendicular impacts, 50 % of the impact force is used.

For reference, Figures 7.5-1 and 7.5-2 include upper bound and lower bound barge tow sizes collision loads calculated as a function of vessel speed.

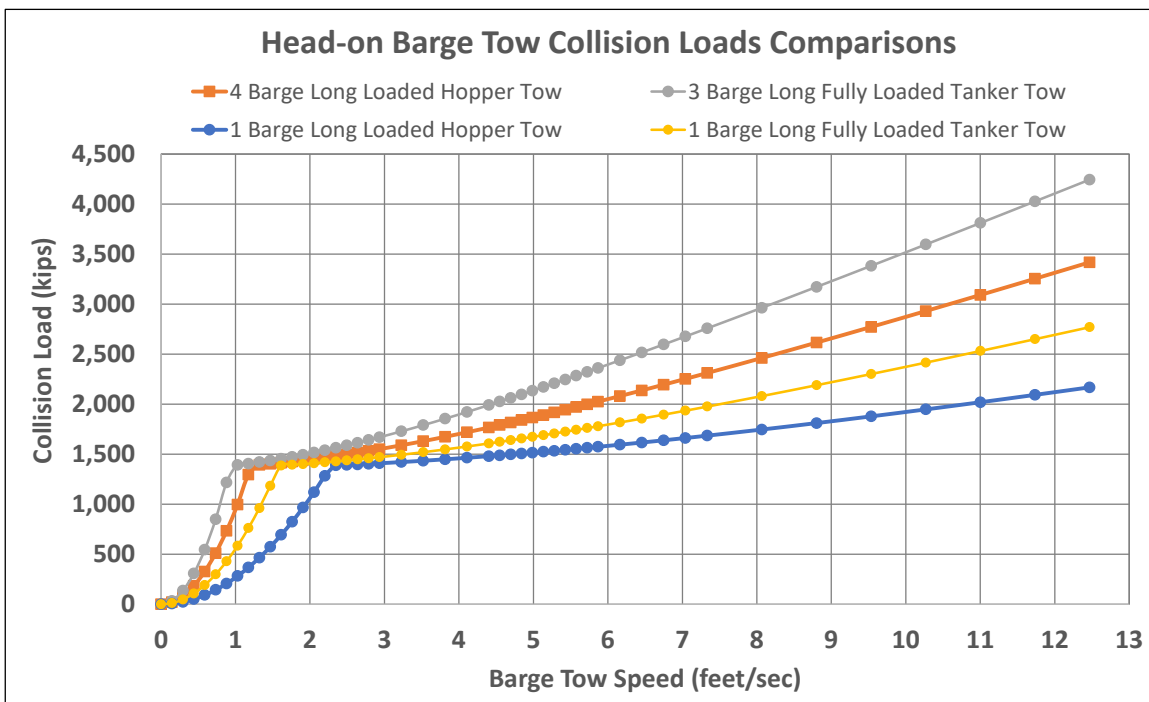


Figure 7.5-1: Barge Collision Loads as a Function of Vessel Speed

## 7.6 Substructure Capacities

### 7.6.1 General

Since vessel collisions with bridges are extreme events with a low probability of occurrence, the capacity limit states used in bridge design are generally based on structural survival criteria (AASHTO 2020). Damage or local collapse of substructure and superstructure elements is permitted to occur provided that the structure maintains its integrity, hazards to traffic are minimized and repairs can be made in a relatively short period of time. Therefore, the evaluation of the bridge member capacities can be based on

the AASHTO (2020) ultimate state design criteria with resistance coefficients equal to 1.0.

### 7.6.2 Existing Bridge Capacities

The existing bridge substructure capacities as determined in the previous study are represented by a lower and upper-level capacities based on upper and lower bound assumptions of the foundation stiffness. The global, nominal pier capacities obtained are presented in Table 7.6-1, in terms of controlling maximum longitudinal and transverse concentrated forces applied at the 2% flowline. The longitudinal direction refers to loading parallel to the channel, while the transverse direction refers to loading perpendicular to the channel.

**Table 7.6-1: Nominal Substructure Capacities (kips)**

| Pier | Parallel to Channel |             | Perpendicular to Channel |             |
|------|---------------------|-------------|--------------------------|-------------|
|      | Lower Level         | Upper Level | Lower Level              | Upper Level |
| 2    | 2,685               | 3,825       | 1,880                    | 2,670       |
| 3    | 2,280               | 3,400       | 1,420                    | 1,530       |
| 4    | 8,175               | 10,410      | 1,670                    | 1,710       |
| 5    | 8,125               | 10,430      | 1,670                    | 1,700       |
| 6    | 765                 | 1,000       | 655                      | 670         |
| 7    | 857                 | 1,100       | 690                      | 720         |
| 8    | 825                 | 1,080       | 690                      | 700         |
| 9    | 880                 | 1,095       | 720                      | 740         |
| 10   | 805                 | 1,060       | 675                      | 680         |
| 11   | 949                 | 1,345       | 760                      | 785         |
| 12   | 965                 | 1,375       | 770                      | 770         |

### 7.7 Design Water Elevation

The water level along with the loading condition of a vessel influence the location of the vessel impact loads, the accessibility of vessels to piers outside the navigation channel, and the susceptibility of the superstructure to vessel hits. The design impact force is applied as a concentrated force on the substructure at the mean high water level (or the 2% flowline) for overall capacity checks, and as a vertical line load distributed along the ship's bow depth with the ship in relation to the mean high water level for localized collision forces.

The 2% flowline established for the bridge site is relatively conservative for vessels in transit. It is about 10 feet higher than the pool elevation.

### 7.8 Probability of Collapse

The probability of collapse (PC) once a bridge substructure element has been struck by an aberrant vessel is a function of many variables, including vessel size, type, forepeak ballast and shape, speed, direction of impact, and mass. It is also dependent on the ultimate lateral strength of the pier, span, or element to resist collision impact loads.

The PC is determined based on the ratio of the structural capacity (H) to the static impact force (P).

## 7.9 Annual Frequencies of Collapse

Annual frequencies of collapse (AF) were determined for each bridge substructure element exposed to vessel impact in both the parallel and perpendicular directions for different barge tow types and configurations. The general expression used is as follows:

$$AF=(N)(PA)(PG)(PC)(PF)$$

where

$N$  = annual number of vessels classified by type, size, and loading condition which can strike the bridge element

$PF$  = adjustment factors for water depth, pier protection and other barriers potential protection

Water depth access factors and pier protection and other barriers potential protection factors are determined and used to adjust the AF calculated for each pier.

The summation of all substructure element frequencies of collapse in the controlling impact direction for both upstream and downstream traffic represents the annual frequency of collapse for the entire substructure.

## 7.10 Bridge Classification Criteria

The classification of a bridge with respect to vessel collision is made by the bridge owner. Based on the *AASHTO Guide Specification and Commentary for Vessel Collision Design of Highway Bridges*, the main factors that need to be considered when determining the classification of a bridge with respect to vessel collision include:

- *Need for civil defense, police, fire department, or public health agencies to respond to an emergency, which might exist on the opposite side of the waterway. Bridges that provide the only continuous transportation route for such emergency situations should be classified as critical.*
- *Social/Survival importance in an emergency or disaster situation.*
- *Role as an important link in the defense highway network. Bridges that are part of the Security/Defense roadway network should be classified as critical.*
- *Availability of alternate detour routes.*
- *Average annual daily traffic.*

Although the SH-100 Bridge crossing can serve as an alternate route, the role of the bridge as an important link in the defense highway network would point towards a critical/essential bridge classification.

The acceptable annual frequency of collapse for design is 0.001 for “typical” bridges and 0.0001 for “critical/essential” bridges.

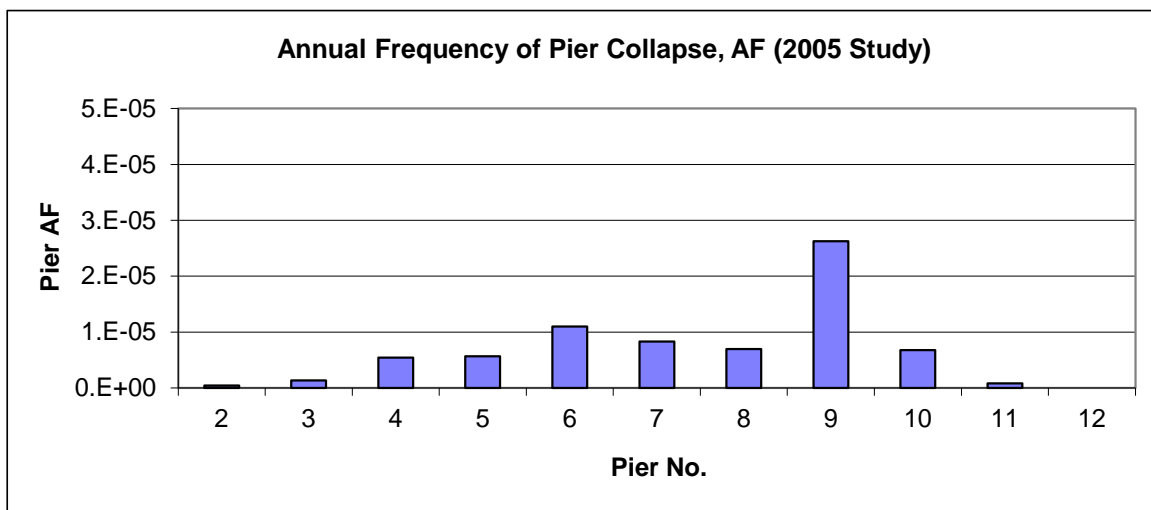
**7.11 Analysis Results for the Existing Bridge – Previous Study**

The annual frequencies of collapse for the substructure from the previous study are summarized in Table 7.11-1 and shown Figure 7.11-1. These results are based on upper limit bridge substructure capacities and site-specific probability of vessel aberrancy. Figure 7.11-1 shows that most of the contribution to the annual frequency of collapse comes from Pier 9, which is exposed to upbound vessels.

The annual frequency of collapse (AF) for the entire substructure based on the previous study vessel traffic was computed as 0.00007 and the projected annual frequency of collapse for the year 2020 was estimated to be 0.00009.

**Table 7.11-1: Annual Frequency of Substructure Collapse – Previous Study**

| Pier          | Controlling    | Controlling    |
|---------------|----------------|----------------|
|               | Case (2005)    | Case (2020)    |
| 2             | 0.00000        | 0.00000        |
| 3             | 0.00000        | 0.00000        |
| 4             | 0.00001        | 0.00001        |
| 5             | 0.00001        | 0.00001        |
| 6             | 0.00001        | 0.00001        |
| 7             | 0.00001        | 0.00001        |
| 8             | 0.00001        | 0.00001        |
| 9             | 0.00003        | 0.00003        |
| 10            | 0.00001        | 0.00001        |
| 11            | 0.00000        | 0.00000        |
| 12            | 0.00000        | 0.00000        |
| <b>Total:</b> | <b>0.00007</b> | <b>0.00009</b> |



**Figure 7.11-1: Annual Frequency of Collapse by Pier - Previous Study**

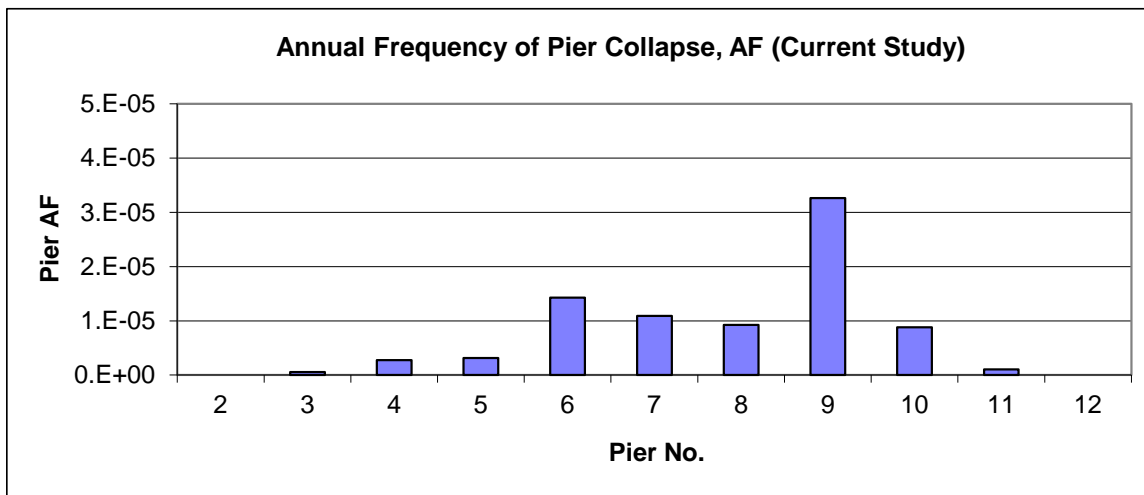
**7.12 Analysis Results for the Existing Bridge – Current Study**

The annual frequencies of collapse for the substructure based on the updated vessel collision analysis are summarized in Table 7.12-1 and shown Figure 7.12-1. Figure 7.11-1 shows that most of the contribution to the annual frequency of collapse comes from Pier 9, which is exposed to upbound vessels.

The annual frequency of collapse (AF) for the entire substructure based on the current study vessel traffic is computed as 0.00008, and the projected annual frequency of collapse for the year 2060 is estimated to be 0.00013.

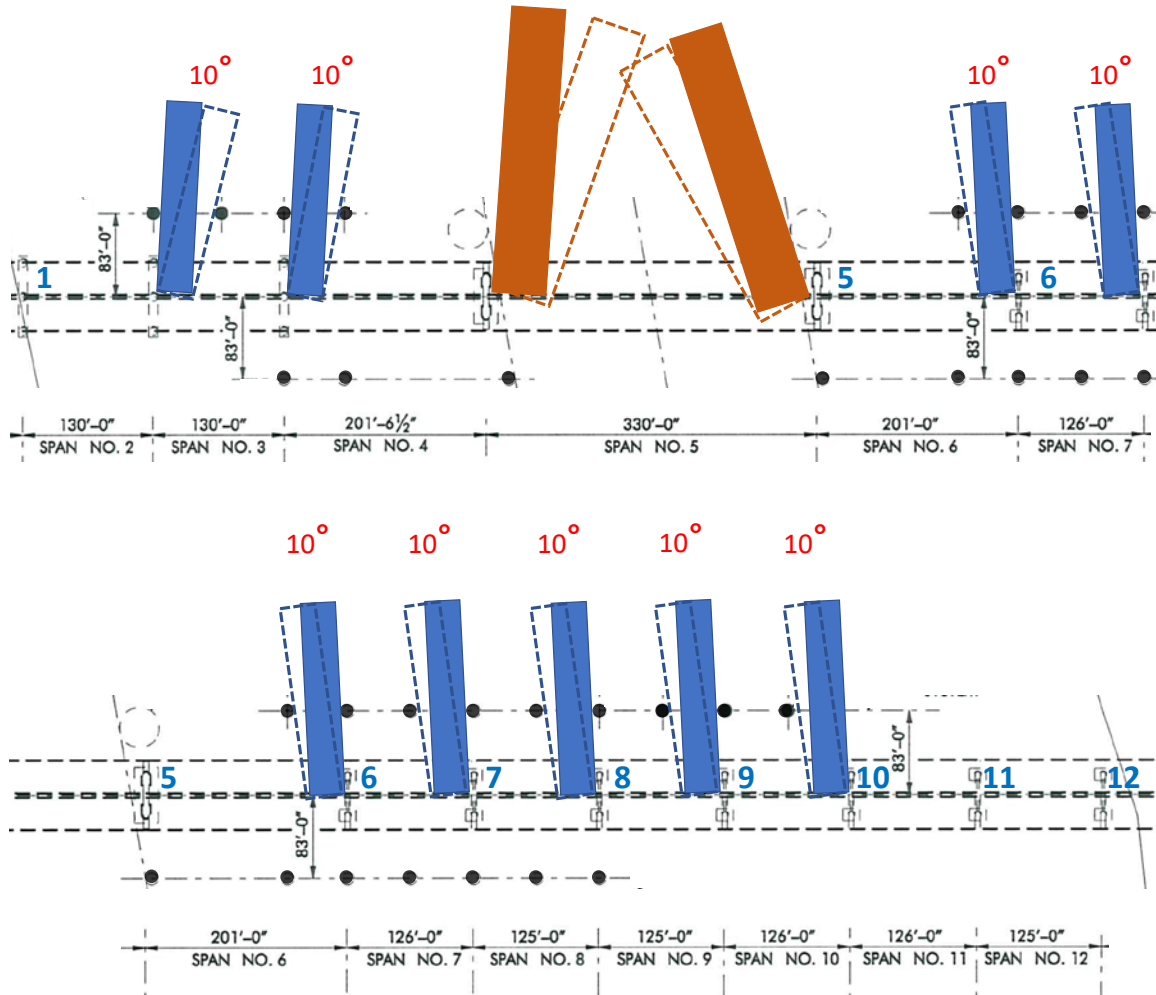
**Table 7.12-1: Annual Frequency of Substructure Collapse – Current Study**

| Pier          | Controlling    | Controlling    |
|---------------|----------------|----------------|
|               | Case (2022)    | Case (2060)    |
| 2             | 0.00000        | 0.00000        |
| 3             | 0.00000        | 0.00000        |
| 4             | 0.00000        | 0.00000        |
| 5             | 0.00001        | 0.00002        |
| 6             | 0.00001        | 0.00002        |
| 7             | 0.00001        | 0.00002        |
| 8             | 0.00001        | 0.00001        |
| 9             | 0.00003        | 0.00005        |
| 10            | 0.00001        | 0.00001        |
| 11            | 0.00000        | 0.00000        |
| 12            | 0.00000        | 0.00000        |
| <b>Total:</b> | <b>0.00008</b> | <b>0.00013</b> |

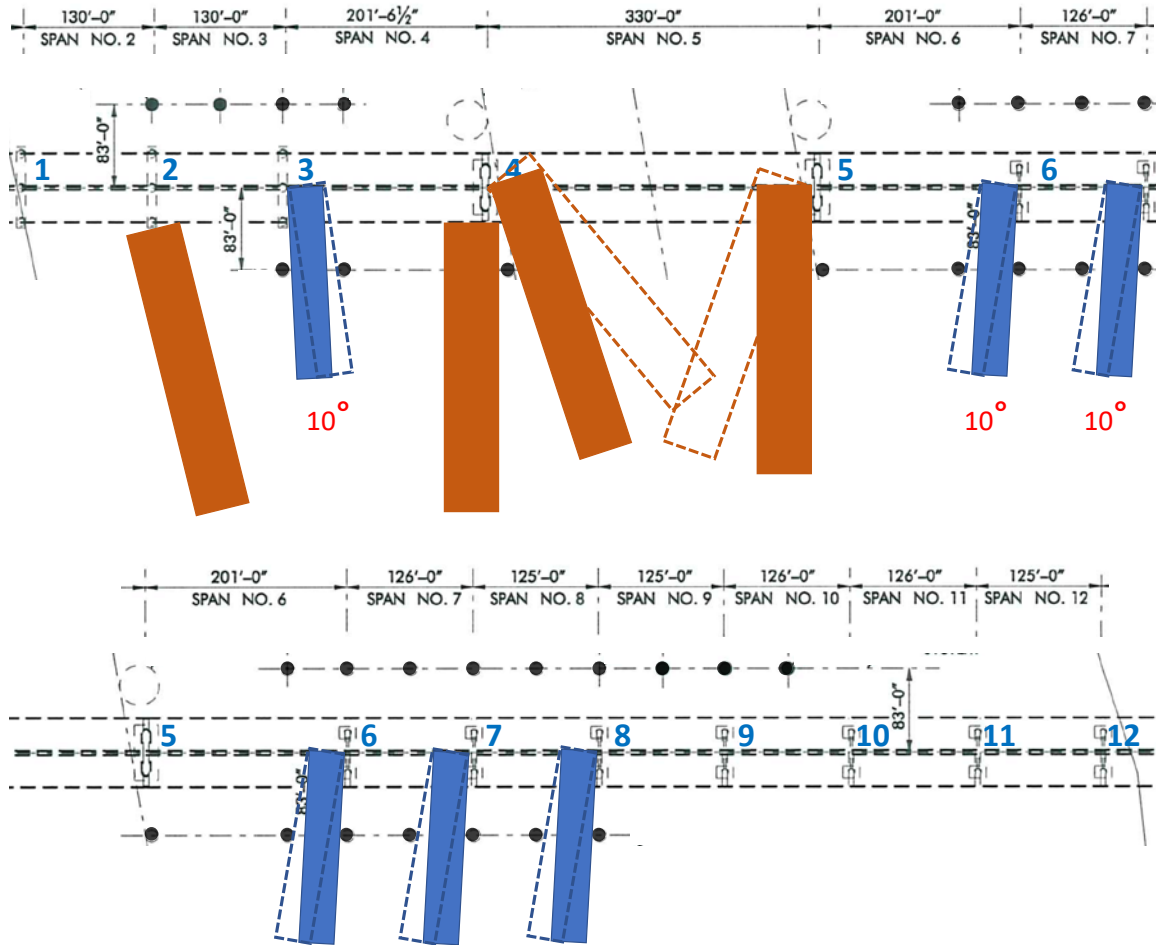


**Figure 7.12-1: Annual Frequency of Collapse by Pier - Current Study**

Figures 7.12-2 and 7.12-3 illustrate the accessibility of hopper and tanker barges to the existing piers for downstream and upstream traffic directions.



**Figure 7.12-2: Accessibility of Hopper and Tanker Barges to the Existing Piers for Downstream Traffic Direction**



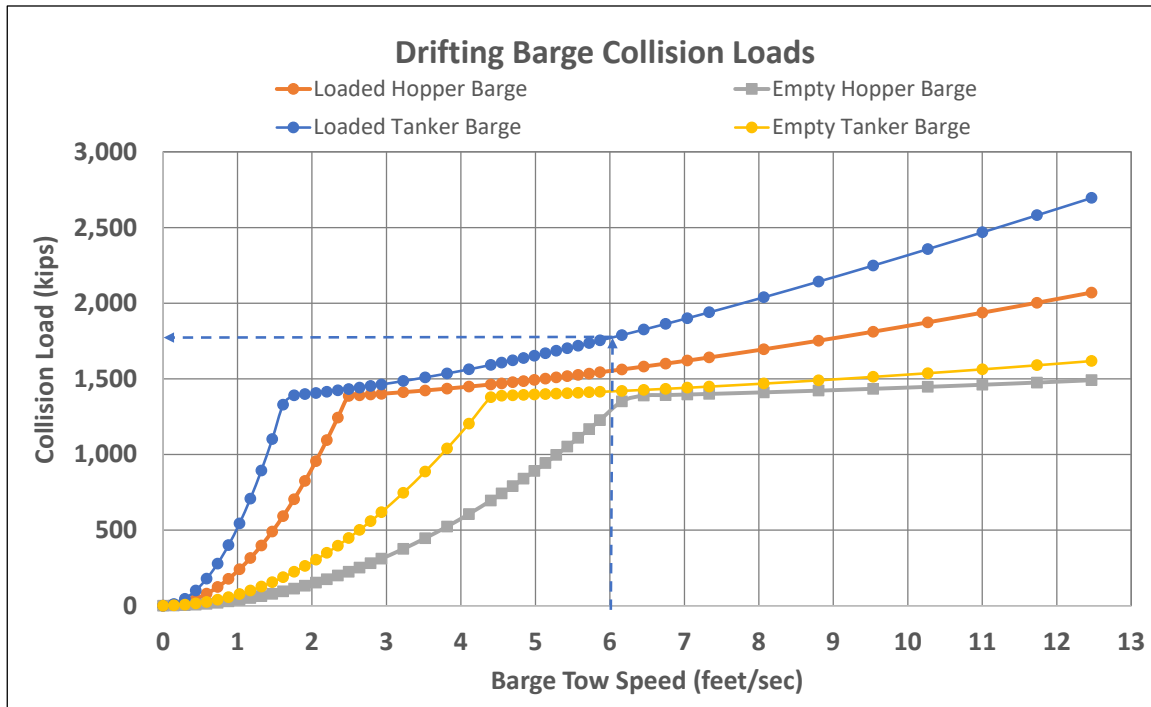
**Figure 7.12-3: Accessibility of Hopper and Tanker Barges to the Existing Piers for Upstream Traffic Direction**

### 7.13 Substructure Capacity Recommendations for the New Bridge

#### 7.13.1 Minimum Impact Load

Although AASHTO allows the use of an empty hopper barge drifting at a speed equal to the yearly mean current for determining the minimum impact load, based on a review of the history of accidents, the use of loaded tanker barge drifting at a speed representative of high-water conditions is recommended.

Figure 7.13-1 includes single empty and loaded hopper and tanker barge collision loads as a function of barge speed. It shows that for vessel speed of 6 ft/sec, representative of high-water conditions, the head-on collision load of a loaded tanker barge is about 1,800 kips.



**Figure 7.13-1: Drifting Single Barge Collision Loads as a Function of Vessel Speed**

**7.13.2 Analysis Results with New Minimum Impact Load Included**

The annual frequencies of collapse when exiting substructure capacities are adjusted for a minimum capacity level of 1,800 kips as shown in Table 7.13-1, are summarized in Table 7.13-2 and shown Figure 7.13-2. Figure 7.13-2 shows that the contribution to the annual frequency of collapse among the piers is more uniformly distributed.

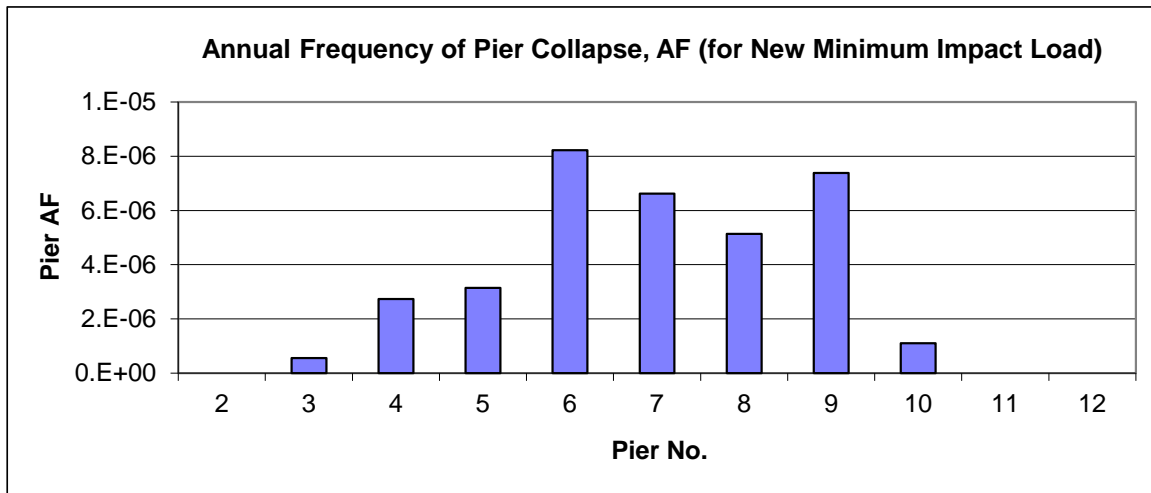
**Table 7.13-1: Adjusted Substructure Capacities for New Minimum Impact Load**

| Pier | Parallel to Channel |          | Perpendicular to Channel |          |
|------|---------------------|----------|--------------------------|----------|
|      | Original            | Modified | Original                 | Modified |
| 2    | 3,825               | 3,825    | 2,670                    | 2,670    |
| 3    | 3,400               | 3,400    | 1,530                    | 1,530    |
| 4    | 10,410              | 10,410   | 1,710                    | 1,710    |
| 5    | 10,430              | 10,430   | 1,700                    | 1,700    |
| 6    | 1,000               | 1,800    | 670                      | 900      |
| 7    | 1,100               | 1,800    | 720                      | 900      |
| 8    | 1,080               | 1,800    | 700                      | 900      |
| 9    | 1,095               | 1,800    | 740                      | 900      |
| 10   | 1,060               | 1,800    | 680                      | 900      |
| 11   | 1,345               | 1,800    | 785                      | 900      |
| 12   | 1,375               | 1,800    | 770                      | 900      |

The annual frequency of collapse (AF) for the entire substructure based on the current study vessel traffic is computed as 0.000035, and the projected annual frequency of collapse for the year 2060 is estimated to be 0.000052.

**Table 7.13-2: Annual Frequency of Substructure Collapse for New Minimum Impact Load**

| Pier          | Controlling     | Controlling     |
|---------------|-----------------|-----------------|
|               | Case (2022)     | Case (2060)     |
| 2             | 0.000000        | 0.000000        |
| 3             | 0.000001        | 0.000001        |
| 4             | 0.000003        | 0.000004        |
| 5             | 0.000003        | 0.000005        |
| 6             | 0.000008        | 0.000012        |
| 7             | 0.000007        | 0.000010        |
| 8             | 0.000005        | 0.000008        |
| 9             | 0.000007        | 0.000011        |
| 10            | 0.000001        | 0.000002        |
| 11            | 0.000000        | 0.000000        |
| 12            | 0.000000        | 0.000000        |
| <b>Total:</b> | <b>0.000035</b> | <b>0.000052</b> |



**Figure 7.13-2: Annual Frequency of Collapse by Pier for New Minimum Impact Load**

*7.13.3 Analysis Results for a No Protection Case*

The annual frequencies of collapse for increased substructure capacities that do not need to rely on independent pier protection (see Table 7.13-3 for recommended capacities) are summarized in Table 7.13-4 and Figure 7.13-3.

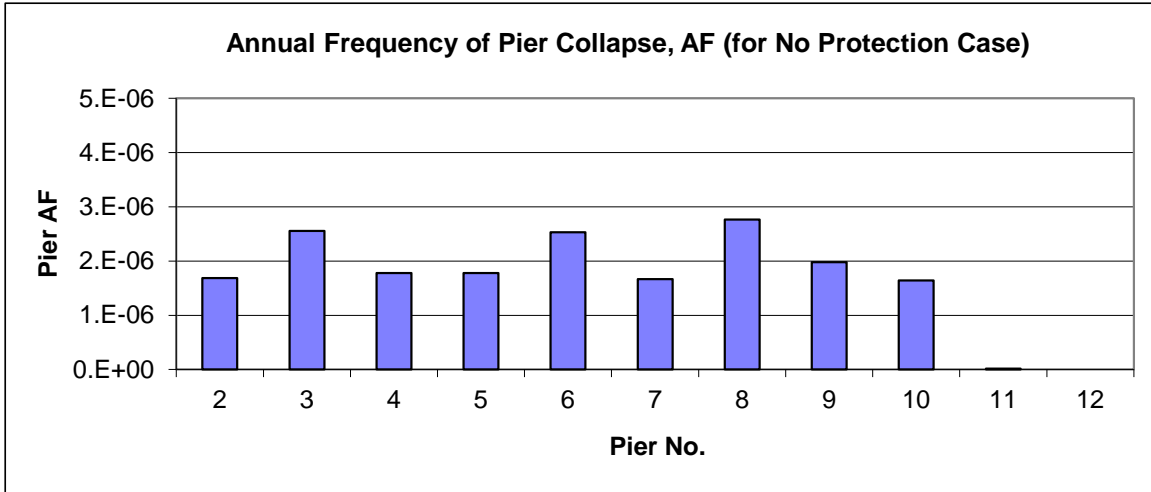
**Table 7.13-3: Adjusted Substructure Capacities for the No Protection Case**

| Pier | Parallel to Channel |                    | Perpendicular to Channel |                    |
|------|---------------------|--------------------|--------------------------|--------------------|
|      | Original            | No Protection Case | Original                 | No Protection Case |
| 2    | 3,825               | <b>3,100</b>       | 2,670                    | <b>1,550</b>       |
| 3    | 3,400               | <b>3,200</b>       | 1,530                    | <b>1,600</b>       |
| 4    | 10,410              | <b>3,500</b>       | 1,710                    | <b>1,750</b>       |
| 5    | 10,430              | <b>3,500</b>       | 1,700                    | <b>1,750</b>       |
| 6    | 1,000               | <b>3,200</b>       | 670                      | <b>1,600</b>       |
| 7    | 1,100               | <b>3,100</b>       | 720                      | <b>1,550</b>       |
| 8    | 1,080               | <b>2,900</b>       | 700                      | <b>1,450</b>       |
| 9    | 1,095               | <b>2,800</b>       | 740                      | <b>1,400</b>       |
| 10   | 1,060               | <b>2,400</b>       | 680                      | <b>1,200</b>       |
| 11   | 1,345               | <b>1,800</b>       | 785                      | <b>900</b>         |
| 12   | 1,375               | <b>1,800</b>       | 770                      | <b>900</b>         |

Table 7.13-4 and Figure 7.13-2 show that the recommended pier capacities result in a relatively uniform distribution of the contribution of the piers to the annual frequency of collapse.

**Table 7.13-4: Annual Frequency of Substructure Collapse for the No Protection Case with the Recommended Substructure Capacities**

| Pier          | Controlling Case (2022) | Controlling Case (2060) |
|---------------|-------------------------|-------------------------|
|               | 2                       | 0.000002                |
| 3             | 0.000002                | 0.000004                |
| 4             | 0.000002                | 0.000003                |
| 5             | 0.000002                | 0.000003                |
| 6             | 0.000003                | 0.000004                |
| 7             | 0.000002                | 0.000003                |
| 8             | 0.000003                | 0.000004                |
| 9             | 0.000002                | 0.000003                |
| 10            | 0.000002                | 0.000002                |
| 11            | 0.000000                | 0.000000                |
| 12            | 0.000000                | 0.000000                |
| <b>Total:</b> | <b>0.000018</b>         | <b>0.000028</b>         |



**Figure 7.13-3: Annual Frequency of Collapse by Pier for the No Protection Case with the Recommended Substructure Capacities**

***7.13.4 Initial Substructure Capacity Recommendation for the New Bridge***

Based on the existing bridge analyses described above, for an initial estimate of an order of magnitude substructure capacity demands, Table 7.13-3 may be used as a guide.

## 8. PREVENTION AND PROTECTION MEASURES

### 8.1 General

Vessel collision with a bridge involves a sequence of events (vessel becomes aberrant, aberrant vessel actually strikes a bridge element and the bridge element hit actually fails). Measures that can reduce the likelihood of vessel aberrancy and the likelihood that an aberrant vessel reaches a vulnerable bridge element can be used to prevent collisions, and bridge protection and motorist warning measures can be used to mitigate the consequences of a collision if it occurs.

Additional measures related to docking operations, mooring and securing of barges to the shore facilities can be used to minimize the likelihood of barge breakaways.

### 8.2 Prevention Measures

#### *8.2.1 Causes of Accidents*

Studies of bridge collision accidents found that the majority of the causes of accidents are related to human performance. However, while the contributing factors to the more frequent accidents at difficult navigation sites are generally consistent with those in the entire maritime industry, the causes of the rare accidents at normal navigation sites were found to center around two main cases; cases in which the vessel operator was not aware that he was out of the navigation channel and cases in which the vessel operator fell asleep or was incapacitated.

#### *8.2.2 Collision Prevention Measures*

Measures for preventing human error in the maritime industry in general and during bridge transits have been identified by various agencies including the U.S. Coast Guard, National Transportation Safety Board and the American Waterway Operators, and many of them have been or are in the process of being implemented. They include

- Development of navigation best practices for transiting bridges vulnerable to collision.
- Training of operators in the application of navigation best practices.
- Requiring route familiarization, posting, or check-ride before an operator is permitted to navigate under a vulnerable bridge.
- Improving Coast Guard-industry information sharing on near misses.
- Requiring the implementation of Crew Endurance Management Systems (CEMS) throughout the towing industry as a means of improving decision making fitness.

Site specific measures that have been used or recommended in the past to reduce the likelihood of collisions at locations that have experienced frequent accidents or at locations where a bridge analysis has shown high risk levels include:

- Adding aids to navigation (33 CFR 118.100-118.140)

- Establishing a Regulated Navigation Area (RNA)
- Passing State legislature to regulate navigational safety in a specific area
- USCG notices to mariners and other publications
- Navigation related warnings published in navigation charts

Navigation regulations on the McClellan-Kerr Arkansas River Navigation System are included in Section 162.9, Title 33 of the Code of Federal Regulations (CFR) *White River, Arkansas Post Canal, Arkansas River, and Verdigris River between Mississippi River, Ark., and Catoosa, Okla.; use, administration, and navigation.*

### **8.3 Physical Protection**

#### ***8.3.1 General***

The main objective of bridge protection measures is to minimize consequences of bridge collision. Bridge protection measures that may be considered at existing bridges that were determined to be at risk of vessel collision include pier strengthening, pier mounted protection or independent pier protection.

Since it is often impossible to provide 100% protection to an existing bridge, cost benefit criteria is an important aspect in the selection of the protection system. Factors that need to be considered include the bridge type and size, the vessel types, the pier capacity and the governing failure modes. It may be economically feasible to strengthen a pier if the local capacity of a slender element above water governs, but much more difficult to strengthen a pier if the overall foundation capacity of a pier in deep water controls.

For a new bridge design, the design of the pier for vessel collision without relying on physical protection to keep the annual frequency of collapse below acceptable levels is often the most cost-effective alternative.

#### ***8.3.2 Site Specific Protection***

The existing pier protection at the I-40 Bridge is described in Sections 2.1, 2.2 and 2.4. It can be used as an integral part of the design of the new bridge or as an added level of protection.

### **8.4 Motorist Warning Systems**

Bridge user warning systems include collision hazard detection measures and bridge traffic control measures. The collision hazard detection options may include vessel impact vibration detectors, continuity circuits or VHF radio link. Bridge traffic control measures may include variable message signs, flashing beacons or movable gates.

It should be noted, however, that many of these systems tend to be complex and of uncertain reliability for infrequent operation over long periods of time. In addition, there

is a need for further investments and development, and for the establishment of a track record. So far, the use of bridge user warning systems has been limited.

## 9. SUMMARY OF FINDINGS AND CONCLUSIONS

The vessel types on the McClellan-Kerr Arkansas River navigation system include mainly hopper and tanker barge tows. The vessel traffic update found an increased volume of traffic consistent with the 30% projection made in the previous study. Although the traffic has dropped in recent years, the expectation is that overall, it will continue to increase and using the mid-life of the new bridge as a target for a future traffic projection year, the use of a 50% increase in the current traffic through 2060 is recommended. The vessel traffic update also found some differences in the distributions of the number of barges per tow and their loading conditions, but overall the updated traffic data was found to fit well the previously used evaluation vessel groups.

The update of the historical marine incidents on the Arkansas and the Verdigris River found a wider mix of incident types along the waterway but no significant changes in the nature and frequency of incidents. Both the previous and the updated accident data on the Verdigris and the Arkansas River generally confirm the tendency for accidents to cluster at certain locations along the waterway, with many of the accidents occurred at lock & dam structures, which are not representative of the conditions at bridge crossings. There have been only two vessel collisions with the I-40 Bridge, one prior to 1983 when a barge tow hit and caused some cracking in one of the channel piers and one in May of 2002 caused the collapse of Spans 1, 2 and 3 and a section of Span 4. The cause of the 2002 collision was attributed to the captain of the towboat becoming incapacitated and was not related to the bridge characteristics or the navigation conditions at the bridge site.

Overall, the frequency of accidents on the McClellan-Kerr Arkansas River Navigation System River is quite low relative to other waterways, especially in the Oklahoma portion. The historical probability of vessel aberrancy base rate was found to be  $3.8 \times 10^{-5}$  for the Oklahoma portion of the McClellan-Kerr Arkansas River Navigation System, which is about 3.2 times lower than the probability of aberrancy base rate value of  $1.2 \times 10^{-4}$  obtained using the AASHTO recommendation when historical accident data is not available.

The history of accidents shows that the threat of barge breakaways to the safety of bridges and other structures has been underestimated in the past. This has further been reinforced by the barge breakaways that occurred during the 2019 flood, one of them resulting in a collision with the Webbers Falls Lock and Dam. Locations where barges can break loose and drift towards the I-40 Bridge included Webbers Falls Lock, the Consolidated Grain and Barge Co Webbers Falls Dock and the Jeffrey Sand Co Sand Plant No 5 Dock. AASHTO addresses barge breakaways by specifying a minimum impact load due to an empty hopper barge travelling at a speed equal to the yearly mean current for the waterway location. However, the review of past accidents due to barge breakaways shows that a more conservative approach that accounts for loaded barge breakaways and higher barge speeds that reflect the actual current speeds during high water events is needed.

The updated waterway data suggests an increase in the frequency of high-water events during which barges can break loose from moorings. This further supports the recommendation previously made that a more conservative approach that accounts for loaded barge breakaways during high water and higher drifting barge speeds is needed. Updated river current velocity data statistics support the previously used averages and the use of 6 feet per second for design purposes for a high-water event.

Vessel collision analysis results are included for a variety of cases in order to get an initial range of substructure capacities for the design of the new bridge.

## 10. REFERENCES

AASHTO (2009 with 2010 Revisions). “Guide Specification and Commentary for Vessel Collision Design of Highway Bridges”, American Association of State Highway and Transportation Officials, Washington, D.C.

AASHTO (2020, 9<sup>th</sup> Ed). “LRFD Specifications for Highway Bridge Design and Commentary”, American Association of State Highway and Transportation Officials, Washington, D.C.

Committee on Ship-Bridge Collisions (1983). “Ship Collisions with Bridges – The Nature of the Accidents, Their Prevention and Mitigation”, Marine Board, Commission on Engineering and Technical Systems, National Research Council, National Academic Press, Washington, D.C., 1983.

Dayton, R.B. (1976). “Analysis of Bridge Collision Accidents”, Vol. I and II, CG-D-77-76 and CG-D-118-76, NTIS AD-A029 034 and AD-AO36 732. U.S. Department of Transportation. May 1976, Washington, D.C.

ENR (1964). “Pontchartrain Bridge Repaired Rapidly”, Engineering News Record, June 25, 1964, pp. 21.

ENR (1974). “Barges Hit Pontchartrain Spans Again”, Engineering News Record, August 8, 1974, pp. 20.

GCMA (2002). “Towboats and Bridges: a Dangerous Mix”, Gulf Coast Mariners Association, Report R-293, June 2002.

INCOM (2001). “Ship Collisions due to Presence of Bridges”, Report of Working Group 19 of the Inland Navigation Commission, International Navigation Association, PIANC General Secretariat, Brussels, Belgium, 2001.

Kristiansen, S. (1983). “Platform Collision Risk on the Norwegian Continental Shelf”, IABSE Colloquium, Preliminary Report, pp. 163-172, 1983.

Paramore, B., Dayton, R. B.; Porricelli, J. D.; Willis, R. M., (1979). “Human and Physical Factors Affecting Collisions, Rammings and Groundings on Western Rivers and Gulf Intracoastal Waterways”, U.S. Coast Guard Report CG-D-80-78, NTIS ADA 074290, January (1979).

U.S. Army Corps of Engineers, Navigation Charts, McClellan Kerr Arkansas River Navigation System.

U.S. Coast Guard (1980). “Program Planning Briefing”, U.S. Coast Guard Headquarters (G-WAN), September 1980.

U.S. Coast Guard (1993). "Review of Marine Safety Issues Related to Uninspected Towing Vessels", December 1993.

U.S. Coast Guard (1995). "Prevention Through People: Quality Action Team Report. Washington, DC.

U.S. Coast Guard-American Waterway Operators, (2003). "Bridge Allision Work Group Report", May 2003.

U.S. Coast Guard (2003). Light List, Volume V, Sections 2 and 3, Arkansas Waterway, U.S. Government Printing Office, Washington, DC.

Waters, J.K., Kriebel, D.L and Mayer, R.H. (1999). "Analysis of U.S. Coast Guard Accident Data", prepared for U.S. Army Corps of Engineers, Institute for Water Resources, Alexandria, VA