

STATE OF OKLAHOMA
DEPARTMENT OF TRANSPORTATION

OKLAHOMA DEPARTMENT OF TRANSPORTATION

PROPOSED
R/W
12/17/2021

PLAN OF PROPOSED
STATE HIGHWAY

FEDERAL AID PROJECT NO. XXX-XXXX(XXX)

INTERCHANGE

I-35 AND SH-74

McCLAIN COUNTY

I-35 CONTROL SECTION NO. 35-44-05

SH-74 CONTROL SECTION NO. 74-44-38

STATE JOB NO. 32802(04)

BRIDGE 'A' - LOCATION NO. 4438 0175X - NBI NO. XXXXX (EXISTING NBI NO. 11034)

BRIDGE 'B' - LOCATION NO. 4405 1252WX - NBI NO. XXXXX (EXISTING NBI NO. 16941)

BRIDGE 'C' - LOCATION NO. 4405 1252EX - NBI NO. XXXXX (EXISTING NBI NO. 16940)

SHEET NO.	INDEX OF SHEETS
	SHEET DESCRIPTION
0001	TITLE
0002-0015	TYPICAL SECTIONS
0016,0017	RIGHT OF WAY DETAILS
0018-0022	PLAN AND PROFILE
0023-0026	SURVEY DATA SHEET
0027-0030	CROSS SECTIONS

ROADWAY	REQUIRED STANDARD DRAWINGS	TRAFFIC
	BRIDGE	

SURVEY DATA
SEE SURVEY DATA ON SHEET NOS. S001 THROUGH S021 FOR COMPLETE INFORMATION.

I-35 DESIGN DATA

AADT 2025 = 31475
AADT 2045 = 40086
DHV (TWO WAY) = 4009
K (DHV/AADT-TWO WAY) = 10%
D (DIRECTIONAL DIST.) = 56%
T (% OF DHV) = 37%
T (% OF AADT) = 37%
T₃ (% OF AADT) = 34%
V = 70 MPH
20 YEAR FLEX. ESALS = 68.02M

SH-74 DESIGN DATA

AADT 2025 = 3734
AADT 2045 = 6934
DHV (TWO WAY) = 763
K (DHV/AADT-TWO WAY) = 11%
D (DIRECTIONAL DIST.) = 54%
T (% OF DHV) = 2%
T (% OF AADT) = 2%
T₃ (% OF AADT) = 1%
V = 45 MPH
20 YEAR FLEX. ESALS = 0.48M

SCALES

PLAN 1" = 50'
PROFILE HORIZONTAL 1" = 50'
PROFILE VERTICAL 1" = 5'
LAYOUT MAP 1" = 2,640'

CONVENTIONAL SYMBOLS

- PROPOSED ROAD
- RAILROADS
- TOWNSHIP AND RANGE
- SECTION LINES
- QUARTER SECTION LINES
- FENCES
- GROUND LINE
- EXISTING ROADS
- BASE LINE
- GRADE LINES
- TELEPHONE AND TELEGRAPH
- POWER LINES
- BUILDINGS
- OIL WELL
- DRAINAGE STRUCTURES - IN PLACE
- DRAINAGE STRUCTURES - NEW
- RIGHT-OF-WAY LINES - EXISTING
- RIGHT-OF-WAY LINES - NEW
- CONTROLLED ACCESS
- RIGHT-OF-WAY FENCE

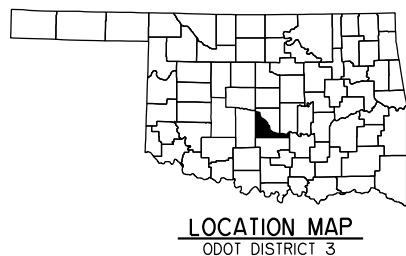
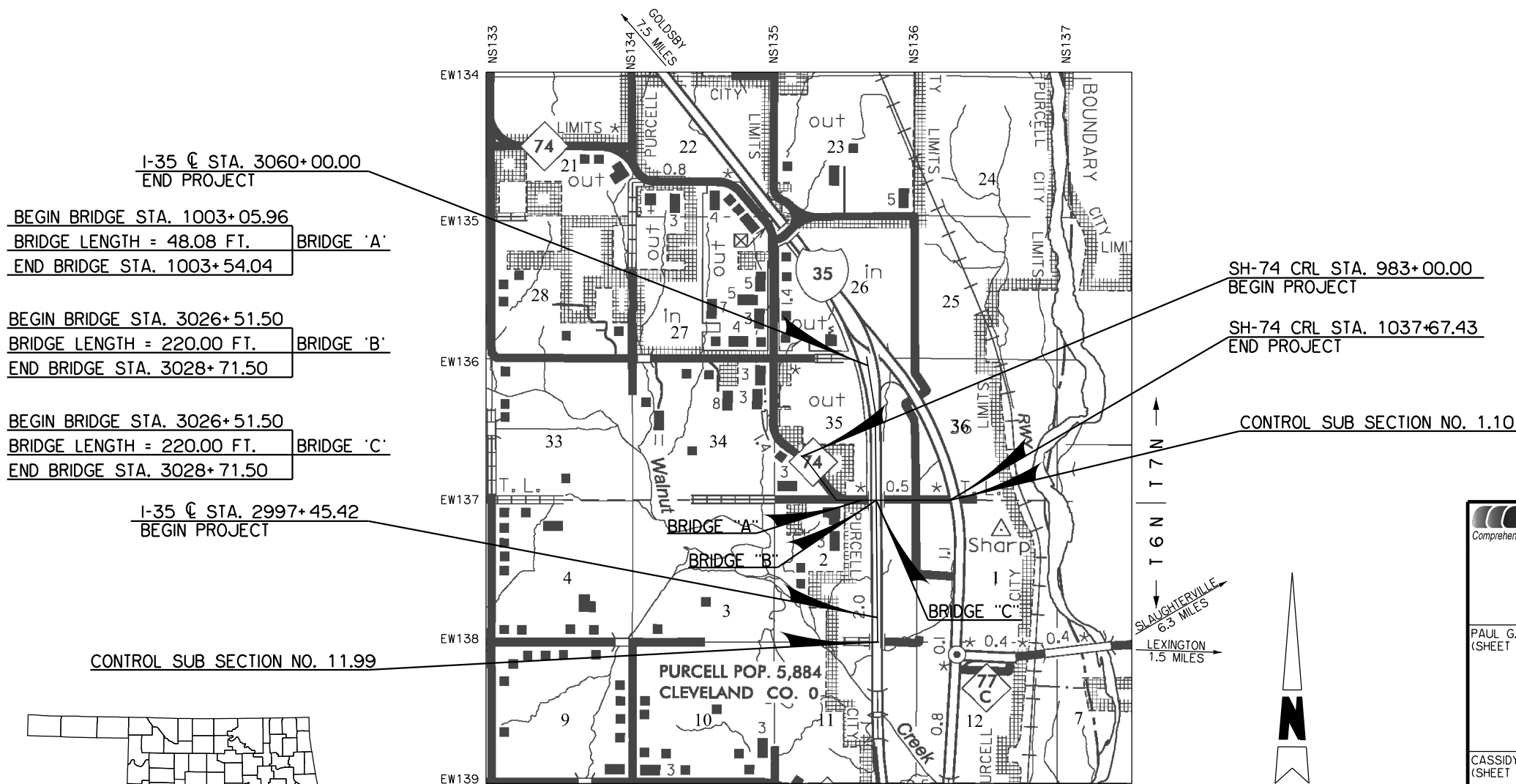

PROJECT LENGTH BASED ON I-35 CENTERLINE SURVEY

ROADWAY LENGTH 6,454.58 FT. 1.222 MILES
BRIDGE LENGTH 440.00 FT. 0.083 MILES
PROJECT LENGTH 6,894.58 FT. 1.305 MILES
EQUATIONS: NONE
EXCEPTIONS: NONE

PROJECT LENGTH BASED ON SH-74 CONSTRUCTION REFERENCE LINE

ROADWAY LENGTH 5,467.43 FT. 1.035 MILES
BRIDGE LENGTH 48.08 FT. 0.009 MILES
PROJECT LENGTH 5,515.51 FT. 1.044 MILES
EQUATIONS: NONE
EXCEPTIONS: NONE

WEST Comprehensive Engineering Services		PREPARED BY: EST, INC. C.A. NO. 3639	615 N. HUDSON, STE. 300 OKLAHOMA CITY, OK 73102 (405) 815-3600
PAUL G. POYNTER, OKLA. REG NO. 19103 (SHEET NOS. 0001, B001-B006)		DATE	THIS DOCUMENT IS PRELIMINARY IN NATURE AND IS NOT A FINAL, SIGNED AND SEALED DOCUMENT.
CASSIDY DOESCHER, OKLA. REG NO. 22540 (SHEET NOS. 0001-0015, R001-R022, X001-X269)		DATE	
OKLAHOMA DEPARTMENT OF TRANSPORTATION		DEPARTMENT OF TRANSPORTATION FEDERAL HIGHWAY ADMINISTRATION	
DATE APPROVED:		DATE APPROVED:	
BY: CHIEF ENGINEER		BY: DIVISION ADMINISTRATOR	
SWO 5398(1) PROJECT NO. 32802(04)		SHEET NO. 0001	

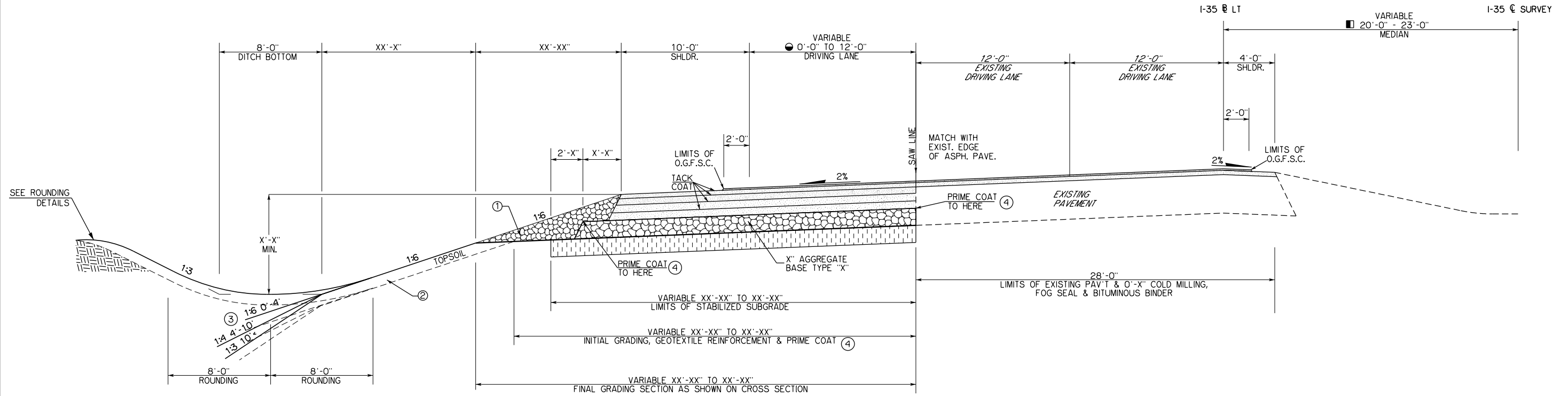

SEE ROUNDING
DETAILS

● 0'-0" TO 11'-1" STA. 2997+45.42 TO STA. 3004+59.20
10'-8" TO 0'-0" STA. 3053+37.20 TO STA. 3060+00.00

PAVEMENT REQUIREMENT		
PAVT. STRUCTURE	0'-0" TO 12'-0" VAR. DRIVING LANES	10'-0" & 4'-0" SHOULDERS
SURFACE COURSE	O.G.F.S.C 2" ON SHOULDERS COVERING ALL DRIVING LANES	
BASE COURSE	X" SUPERPAVE TYPE S4 (PG 76-28 OK)	X" SUPERPAVE TYPE S4 (PG 64-22 OK)
	X" SUPERPAVE TYPE S3 (PG 76-28 OK)	X" SUPERPAVE TYPE S3 (PG 64-22 OK)
	X" SUPERPAVE TYPE S3 (PG 64-22 OK)	X" SUPERPAVE TYPE S3 (PG 64-22 OK)
	X" SUPERPAVE TYPE S3 (PG 64-22 OK)	X" SUPERPAVE TYPE S3 (PG 64-22 OK)

SHIFT EXISTING CROWN TO I-35 @ LT

■ 20'-0" TO 23'-0" STA. 2997+45.42 TO STA. 2999+00.00
23'-0" TO 20'-0" STA. 3059+00.00 TO STA. 3060+00.00

TYPICAL SECTION NO. 1
1-35 @ LT (WIDEN & OVERLAY)

STA. 2997+45.42 TO STA. 3004+59.20
STA. 3053+37.20 TO STA. 3060+00.00

① BACKFILL NOTE:
TO BE BACKFILLED AND COMPACTED AS PART OF THE FINISHING OPERATIONS. QUANTITY IS MEASURED AS TBSC.

② TOPSOIL NOTE:
THE CONTRACTOR SHALL STRIP ALL OF THE AVAILABLE TOPSOIL, STOCKPILE IT, AND PLACE IT BACK ON THE SECTION IN ACCORDANCE WITH SECTION 205 OF THE STANDARD SPECIFICATIONS. RESERVED TOPSOIL SHALL BE SPREAD FIRST ON THE COMPLETED SLOPES OF THE CUT SECTIONS AND THE REMAINDER ON THE COMPLETED FILL SLOPES OR OTHER PRIORITY AREAS LOCATED BY THE ENGINEER. ALL ADDITIONAL COSTS ASSOCIATED WITH OPERATIONS SHALL BE INCLUDED IN THE PAY ITEM SALVAGED TOPSOIL, LUMP SUM.

THE GRADING LINE AS SHOWN ON THE TYPICAL AND CROSS SECTIONS IS TO THE TOP OF THE TOPSOIL. EARTHWORK QUANTITIES WERE NOT ADJUSTED FOR SALVAGE AND THE TOPSOIL QUANTITY IS INCLUDED IN THE MASSLINE BALANCE.

③ DISTANCE MEASURED VERTICALLY FROM THE EDGE OF FINISHED GRADE SHOULDER.

④ PRIME COAT ESTIMATED AT 0.35 GAL. PER SQ. YD. ON TOP OF COMPLETED SUBGRADE, AND 0.25 GAL. PER SQ. YD. ON TOP OF AGGREGATE BASE.

ROUNDING DETAIL

● INTERSECTION OF CUT AND/OR FILL SLOPES WITH GROUND LINE TO BE ROUNDED AS PART OF FINISHING OPERATIONS. ROUNDED SHALL BE 5' MINIMUM FOR SMALLER CUTS AND FILLS TO 15' MAXIMUM FOR LARGER CUTS AND FILLS OR AS DESIGNATED BY THE ENGINEER. COST OF ROUNDING TO BE INCLUDED IN PRICE BID FOR OTHER ITEMS OF WORK.

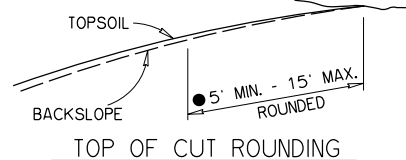
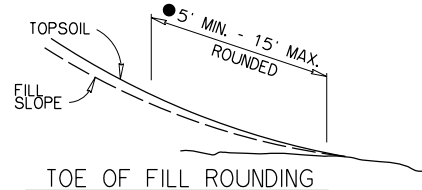

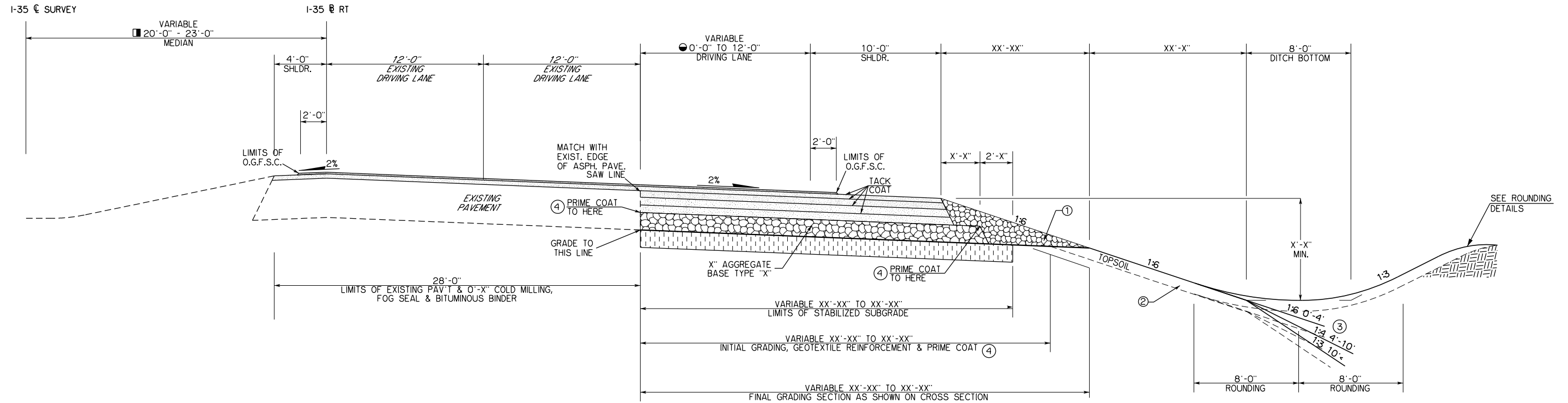

● 0'-0" TO 10'-0" STA. 2997+45.42 TO STA. 3004+59.20
10'-2" TO 0'-0" STA. 3053+37.20 TO STA. 3060+00.00

■ SHIFT EXISTING CROWN TO I-35 @ RT
20'-0" TO 23'-0" STA. 2997+45.42 TO STA. 2999+00.00
23'-0" TO 20'-0" STA. 3059+00.00 TO STA. 3060+00.00

PAVEMENT REQUIREMENT		
PAVT. STRUCTURE	0'-0" TO 12'-0" VAR. DRIVING LANE	10'-0" & 4'-0" SHOULDERS
SURFACE COURSE	O.G.F.S.C 2" ON SHOULDERS COVERING ALL DRIVING LANES	
BASE COURSE	X" SUPERPAVE TYPE S4 (PG 76-28 OK)	X" SUPERPAVE TYPE S4 (PG 64-22 OK)
	X" SUPERPAVE TYPE S3 (PG 76-28 OK)	X" SUPERPAVE TYPE S3 (PG 64-22 OK)
	X" SUPERPAVE TYPE S3 (PG 64-22 OK)	X" SUPERPAVE TYPE S3 (PG 64-22 OK)
	X" SUPERPAVE TYPE S3 (PG 64-22 OK)	X" SUPERPAVE TYPE S3 (PG 64-22 OK)

TYPICAL SECTION NO. 2
I-35 @ RT (WIDEN & OVERLAY)
STA. 2997+45.42 TO STA. 3004+59.20
STA. 3053+37.20 TO STA. 3059+69.40

- ① BACKFILL NOTE:
TO BE BACKFILLED AND COMPACTED AS PART OF THE FINISHING OPERATIONS. QUANTITY IS MEASURED AS TBSC.
- ② TOPSOIL NOTE:
THE CONTRACTOR SHALL STRIP ALL OF THE AVAILABLE TOPSOIL, STOCKPILE IT, AND PLACE IT BACK ON THE SECTION IN ACCORDANCE WITH SECTION 205 OF THE STANDARD SPECIFICATIONS. RESERVED TOPSOIL SHALL BE SPREAD FIRST ON THE COMPLETED SLOPES OF THE CUT SECTIONS AND THE REMAINDER ON THE COMPLETED FILL SLOPES OR OTHER PRIORITY AREAS LOCATED BY THE ENGINEER. ALL ADDITIONAL COSTS ASSOCIATED WITH OPERATIONS SHALL BE INCLUDED IN THE PAY ITEM SALVAGED TOPSOIL, LUMP SUM.

THE GRADING LINE AS SHOWN ON THE TYPICAL AND CROSS SECTIONS IS TO THE TOP OF THE TOPSOIL. EARTHWORK QUANTITIES WERE NOT ADJUSTED FOR SALVAGE AND THE TOPSOIL QUANTITY IS INCLUDED IN THE MASSLINE BALANCE.
- ③ DISTANCE MEASURED VERTICALLY FROM THE EDGE OF FINISHED GRADE SHOULDER.
- ④ PRIME COAT ESTIMATED AT 0.35 GAL. PER SQ. YD. ON TOP OF COMPLETED SUBGRADE, AND 0.25 GAL. PER SQ. YD. ON TOP OF AGGREGATE BASE.

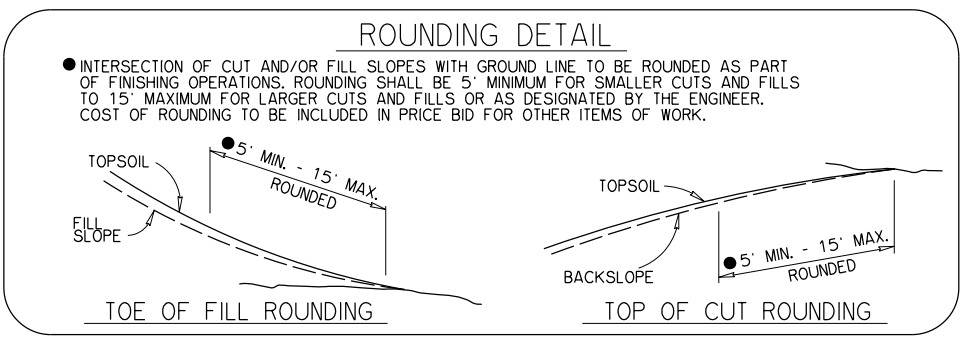

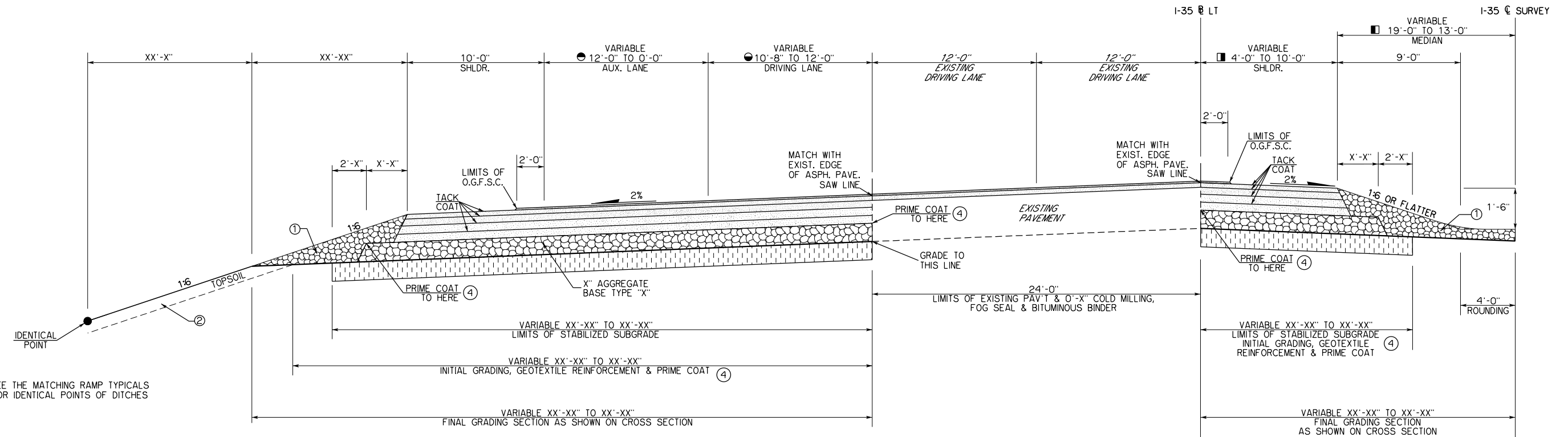

● SEE THE MATCHING RAMP TYPICALS FOR IDENTICAL POINTS OF DITCHES

PAVEMENT REQUIREMENT		
PAVT. STRUCTURE	12'-0" TO 0'-0" VAR. AUX. & DRIVING LANES	10'-0" TO 4'-0" VAR. SHOULDERS
SURFACE COURSE	O.G.F.S.C 2" ON SHOULDERS COVERING ALL DRIVING LANES	
BASE COURSE	X" SUPERPAVE TYPE S4 (PG 76-28 OK)	X" SUPERPAVE TYPE S4 (PG 64-22 OK)
	X" SUPERPAVE TYPE S3 (PG 76-28 OK)	X" SUPERPAVE TYPE S3 (PG 64-22 OK)
	X" SUPERPAVE TYPE S3 (PG 64-22 OK)	X" SUPERPAVE TYPE S3 (PG 64-22 OK)
	X" SUPERPAVE TYPE S3 (PG 64-22 OK)	X" SUPERPAVE TYPE S3 (PG 64-22 OK)

TYPICAL SECTION NO. 3
1-35 & LT (WIDEN & OVERLAY)
STA. 3004+59.20 TO STA. 3013+00.00
STA. 3047+00.00 TO STA. 3053+37.20

- 11'-1" TO 12'-0" STA. 3004+59.20 TO STA. 3007+40.00
- 12'-0" TO 12'-0" STA. 3007+40.00 TO STA. 3013+00.00
- 12'-0" TO 12'-0" STA. 3047+00.00 TO STA. 3050+01.56
- 12'-0" TO 10'-8" STA. 3050+01.56 TO STA. 3053+37.20
- 0'-0" TO 0'-0" STA. 3004+59.20 TO STA. 3010+00.00
- 0'-0" TO 12'-0" STA. 3010+00.00 TO STA. 3013+00.00
- 12'-0" TO 12'-0" STA. 3047+00.00 TO STA. 3047+04.35
- 12'-0" TO 0'-0" STA. 3047+04.35 TO STA. 3050+01.56
- 0'-0" TO 0'-0" STA. 3050+01.56 TO STA. 3053+37.20

- 4'-0" TO 10'-0" STA. 3004+59.20 TO STA. 3007+40.00
- 10'-0" TO 10'-0" STA. 3007+40.00 TO STA. 3013+00.00
- 10'-0" TO 10'-0" STA. 3047+00.00 TO STA. 3050+55.00
- 10'-0" TO 4'-0" STA. 3050+55.00 TO STA. 3053+37.20
- 19'-0" TO 13'-0" STA. 3004+59.20 TO STA. 3007+40.00
- 13'-0" TO 13'-0" STA. 3007+40.00 TO STA. 3013+00.00
- 13'-0" TO 13'-0" STA. 3047+00.00 TO STA. 3050+01.56
- 13'-0" TO 19'-0" STA. 3050+01.56 TO STA. 3053+37.20

- ① BACKFILL NOTE:
TO BE BACKFILLED AND COMPACTED AS PART OF THE FINISHING OPERATIONS. QUANTITY IS MEASURED AS TBSC.
- ② TOPSOIL NOTE:
THE CONTRACTOR SHALL STRIP ALL OF THE AVAILABLE TOPSOIL, STOCKPILE IT, AND PLACE IT BACK ON THE SECTION IN ACCORDANCE WITH SECTION 205 OF THE STANDARD SPECIFICATIONS. RESERVED TOPSOIL SHALL BE SPREAD FIRST ON THE COMPLETED SLOPES OF THE CUT SECTIONS AND THE REMAINDER ON THE COMPLETED FILL SLOPES OR OTHER PRIORITY AREAS LOCATED BY THE ENGINEER. ALL ADDITIONAL COSTS ASSOCIATED WITH OPERATIONS SHALL BE INCLUDED IN THE PAY ITEM SALVAGED TOPSOIL, LUMP SUM.

THE GRADING LINE AS SHOWN ON THE TYPICAL AND CROSS SECTIONS IS TO THE TOP OF THE TOPSOIL. EARTHWORK QUANTITIES WERE NOT ADJUSTED FOR SALVAGE AND THE TOPSOIL QUANTITY IS INCLUDED IN THE MASSLINE BALANCE.
- ③ DISTANCE MEASURED VERTICALLY FROM THE EDGE OF FINISHED GRADE SHOULDER.
- ④ PRIME COAT ESTIMATED AT 0.35 GAL. PER SQ. YD. ON TOP OF COMPLETED SUBGRADE, AND 0.25 GAL. PER SQ. YD. ON TOP OF AGGREGATE BASE.

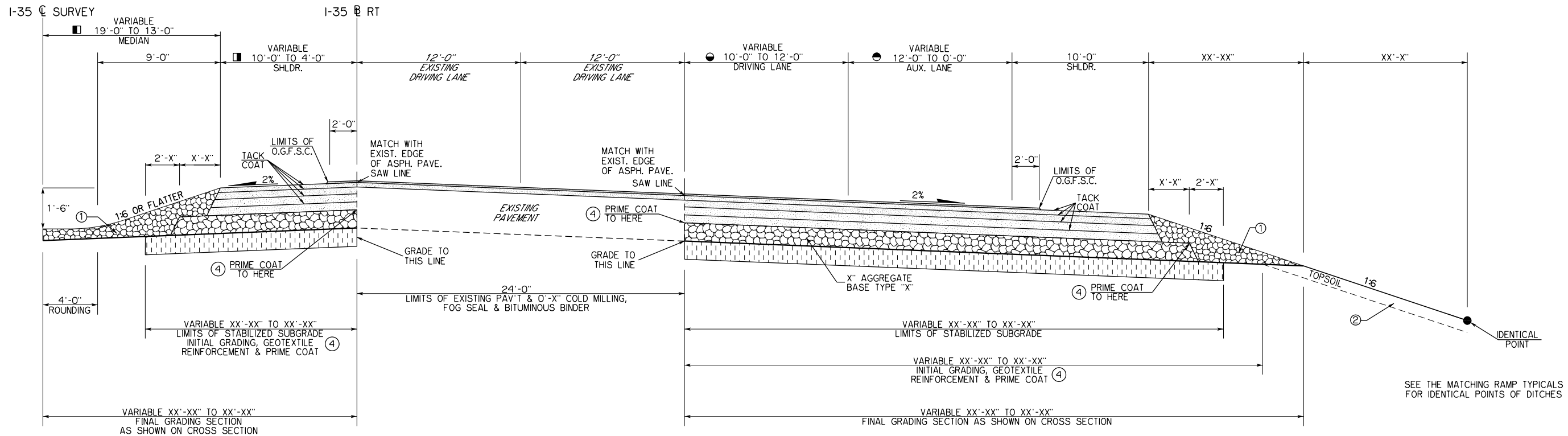

■	4'-0" TO 10'-0"	STA. 3004+59.20 TO STA. 3007+40.00
	10'-0" TO 10'-0"	STA. 3007+40.00 TO STA. 3011+00.00
■	10'-0" TO 10'-0"	STA. 3042+00.00 TO STA. 3050+01.56
	10'-0" TO 4'-0"	STA. 3050+01.56 TO STA. 3053+37.20
■	19'-0" TO 13'-0"	STA. 3004+59.20 TO STA. 3007+40.00
	13'-0" TO 13'-0"	STA. 3007+40.00 TO STA. 3011+00.00
■	13'-0" TO 13'-0"	STA. 3042+00.00 TO STA. 3050+01.56
	13'-0" TO 19'-0"	STA. 3050+01.56 TO STA. 3053+37.20

PAVEMENT REQUIREMENT		
PAVT. STRUCTURE	12'-0" TO 0'-0" VAR. AUX. & DRIVING LANES	10'-0" TO 4'-0" VAR. SHOULDERS
SURFACE COURSE	O.G.F.S.C 2" ON SHOULDERS COVERING ALL DRIVING LANES	
BASE COURSE	X" SUPERPAVE TYPE S4 (PG 76-28 OK)	X" SUPERPAVE TYPE S4 (PG 64-22 OK)
	X" SUPERPAVE TYPE S3 (PG 76-28 OK)	X" SUPERPAVE TYPE S3 (PG 64-22 OK)
	X" SUPERPAVE TYPE S3 (PG 64-22 OK)	X" SUPERPAVE TYPE S3 (PG 64-22 OK)
	X" SUPERPAVE TYPE S3 (PG 64-22 OK)	X" SUPERPAVE TYPE S3 (PG 64-22 OK)

TYPICAL SECTION NO. 4
1-35 B RT (WIDEN & OVERLAY)
STA. 3004+59.20 TO STA. 3011+00.00
STA. 3042+00.00 TO STA. 3053+37.20

●	10'-0" TO 12'-0"	STA. 3004+59.20 TO STA. 3007+40.00
●	12'-0" TO 12'-0"	STA. 3007+40.00 TO STA. 3011+00.00
●	12'-0" TO 12'-0"	STA. 3047+04.35 TO STA. 3050+01.56
●	12'-0" TO 10'-2"	STA. 3050+01.56 TO STA. 3053+37.20
●	0'-0" TO 0'-0"	STA. 3004+59.20 TO STA. 3008+00.00
●	0'-0" TO 12'-0"	STA. 3008+00.00 TO STA. 3011+00.00
●	12'-0" TO 0'-0"	STA. 3042+00.00 TO STA. 3045+00.00
●	0'-0" TO 0'-0"	STA. 3045+00.00 TO STA. 3053+37.20

- ① BACKFILL NOTE:
TO BE BACKFILLED AND COMPACTED AS PART OF THE FINISHING OPERATIONS. QUANTITY IS MEASURED AS TBSC.
- ② TOPSOIL NOTE:
THE CONTRACTOR SHALL STRIP ALL OF THE AVAILABLE TOPSOIL, STOCKPILE IT, AND PLACE IT BACK ON THE SECTION IN ACCORDANCE WITH SECTION 205 OF THE STANDARD SPECIFICATIONS. RESERVED TOPSOIL SHALL BE SPREAD FIRST ON THE COMPLETED SLOPES OF THE CUT SECTIONS AND THE REMAINDER ON THE COMPLETED FILL SLOPES OR OTHER PRIORITY AREAS LOCATED BY THE ENGINEER. ALL ADDITIONAL COSTS ASSOCIATED WITH OPERATIONS SHALL BE INCLUDED IN THE PAY ITEM SALVAGED TOPSOIL, LUMP SUM.

THE GRADING LINE AS SHOWN ON THE TYPICAL AND CROSS SECTIONS IS TO THE TOP OF THE TOPSOIL. EARTHWORK QUANTITIES WERE NOT ADJUSTED FOR SALVAGE AND THE TOPSOIL QUANTITY IS INCLUDED IN THE MASSLINE BALANCE.
- ③ PRIME COAT ESTIMATED AT 0.35 GAL. PER SQ. YD. ON TOP OF COMPLETED SUBGRADE, AND 0.25 GAL. PER SQ. YD. ON TOP OF AGGREGATE BASE.

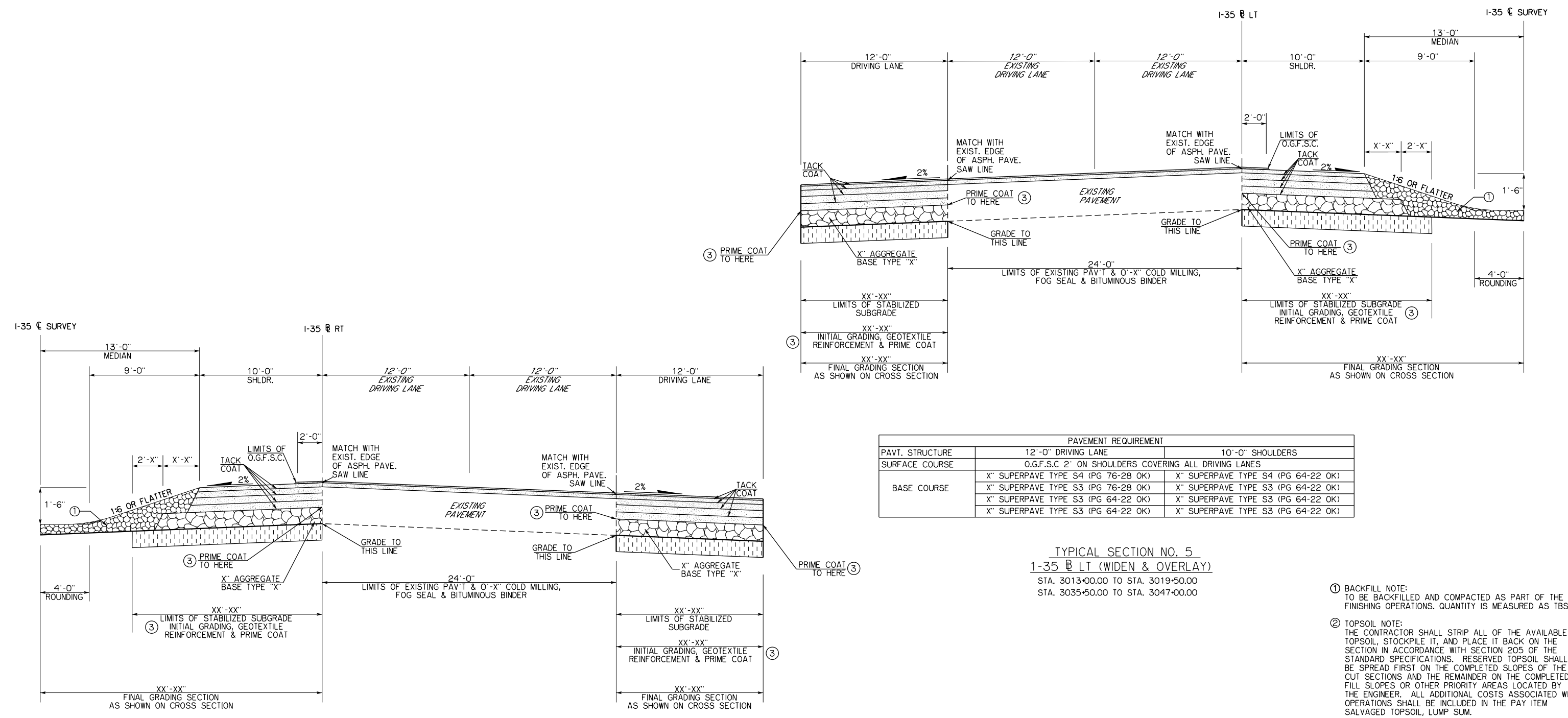

PAVEMENT REQUIREMENT		
PAVT. STRUCTURE	12'-0" DRIVING LANE	10'-0" SHOULDERS
SURFACE COURSE	O.G.F.S.C 2" ON SHOULDERS COVERING ALL DRIVING LANES	
BASE COURSE	X" SUPERPAVE TYPE S4 (PG 76-28 OK)	X" SUPERPAVE TYPE S4 (PG 64-22 OK)
	X" SUPERPAVE TYPE S3 (PG 76-28 OK)	X" SUPERPAVE TYPE S3 (PG 64-22 OK)
	X" SUPERPAVE TYPE S3 (PG 64-22 OK)	X" SUPERPAVE TYPE S3 (PG 64-22 OK)
	X" SUPERPAVE TYPE S3 (PG 64-22 OK)	X" SUPERPAVE TYPE S3 (PG 64-22 OK)

TYPICAL SECTION NO. 5
1-35 LT (WIDEN & OVERLAY)
 STA. 3013+00.00 TO STA. 3019+50.00
 STA. 3035+50.00 TO STA. 3047+00.00

PAVEMENT REQUIREMENT		
PAVT. STRUCTURE	12'-0" DRIVING LANE	10'-0" SHOULDERS
SURFACE COURSE	O.G.F.S.C 2" ON SHOULDERS COVERING ALL DRIVING LANES	
BASE COURSE	X" SUPERPAVE TYPE S4 (PG 76-28 OK)	X" SUPERPAVE TYPE S4 (PG 64-22 OK)
	X" SUPERPAVE TYPE S3 (PG 76-28 OK)	X" SUPERPAVE TYPE S3 (PG 64-22 OK)
	X" SUPERPAVE TYPE S3 (PG 64-22 OK)	X" SUPERPAVE TYPE S3 (PG 64-22 OK)
	X" SUPERPAVE TYPE S3 (PG 64-22 OK)	X" SUPERPAVE TYPE S3 (PG 64-22 OK)

TYPICAL SECTION NO. 6
1-35 RT (WIDEN & OVERLAY)
 STA. 3011+00.00 TO STA. 3019+50.00
 STA. 3035+50.00 TO STA. 3042+00.00

- ① BACKFILL NOTE:
TO BE BACKFILLED AND COMPACTED AS PART OF THE FINISHING OPERATIONS. QUANTITY IS MEASURED AS TBSC.
- ② TOPSOIL NOTE:
THE CONTRACTOR SHALL STRIP ALL OF THE AVAILABLE TOPSOIL, STOCKPILE IT, AND PLACE IT BACK ON THE SECTION IN ACCORDANCE WITH SECTION 205 OF THE STANDARD SPECIFICATIONS. RESERVED TOPSOIL SHALL BE SPREAD FIRST ON THE COMPLETED SLOPES OF THE CUT SECTIONS AND THE REMAINDER ON THE COMPLETED FILL SLOPES OR OTHER PRIORITY AREAS LOCATED BY THE ENGINEER. ALL ADDITIONAL COSTS ASSOCIATED WITH OPERATIONS SHALL BE INCLUDED IN THE PAY ITEM SALVAGED TOPSOIL, LUMP SUM.

THE GRADING LINE AS SHOWN ON THE TYPICAL AND CROSS SECTIONS IS TO THE TOP OF THE TOPSOIL. EARTHWORK QUANTITIES WERE NOT ADJUSTED FOR SALVAGE AND THE TOPSOIL QUANTITY IS INCLUDED IN THE MASSLINE BALANCE.
- ③ PRIME COAT ESTIMATED AT 0.35 GAL. PER SQ. YD. ON TOP OF COMPLETED SUBGRADE, AND 0.25 GAL. PER SQ. YD. ON TOP OF AGGREGATE BASE.

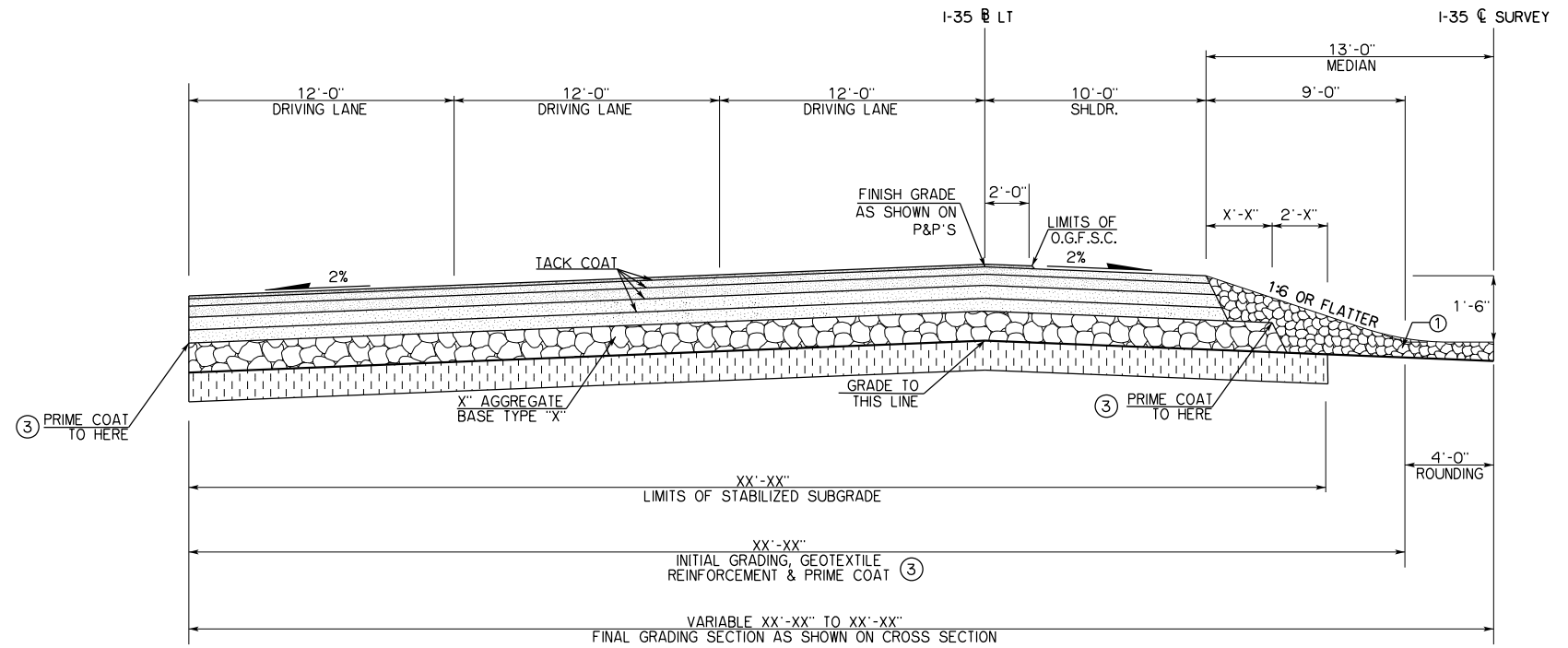

PAVT. STRUCTURE	PAVEMENT REQUIREMENT	
	12'-0" DRIVING LANES	10'-0" SHOULDERS
SURFACE COURSE	O.G.F.S.C 2" ON SHOULDERS COVERING ALL DRIVING LANES	
BASE COURSE	X" SUPERPAVE TYPE S4 (PG 76-28 OK)	X" SUPERPAVE TYPE S4 (PG 64-22 OK)
	X" SUPERPAVE TYPE S3 (PG 76-28 OK)	X" SUPERPAVE TYPE S3 (PG 64-22 OK)
	X" SUPERPAVE TYPE S3 (PG 64-22 OK)	X" SUPERPAVE TYPE S3 (PG 64-22 OK)
	X" SUPERPAVE TYPE S3 (PG 64-22 OK)	X" SUPERPAVE TYPE S3 (PG 64-22 OK)

TYPICAL SECTION NO. 7
1-35 @ LT
STA. 3019+50.00 TO STA. 3020+15.19

- ① BACKFILL NOTE:
TO BE BACKFILLED AND COMPACTED AS PART OF THE FINISHING OPERATIONS. QUANTITY IS MEASURED AS TBSC.
- ② TOPSOIL NOTE:
THE CONTRACTOR SHALL STRIP ALL OF THE AVAILABLE TOPSOIL, STOCKPILE IT, AND PLACE IT BACK ON THE SECTION IN ACCORDANCE WITH SECTION 205 OF THE STANDARD SPECIFICATIONS. RESERVED TOPSOIL SHALL BE SPREAD FIRST ON THE COMPLETED SLOPES OF THE CUT SECTIONS AND THE REMAINDER ON THE COMPLETED FILL SLOPES OR OTHER PRIORITY AREAS LOCATED BY THE ENGINEER. ALL ADDITIONAL COSTS ASSOCIATED WITH OPERATIONS SHALL BE INCLUDED IN THE PAY ITEM SALVAGED TOPSOIL, LUMP SUM.
- ③ PRIME COAT ESTIMATED AT 0.35 GAL. PER SQ. YD. ON TOP OF COMPLETED SUBGRADE, AND 0.25 GAL. PER SQ. YD. ON TOP OF AGGREGATE BASE.

THE GRADING LINE AS SHOWN ON THE TYPICAL AND CROSS SECTIONS IS TO THE TOP OF THE TOPSOIL. EARTHWORK QUANTITIES WERE NOT ADJUSTED FOR SALVAGE AND THE TOPSOIL QUANTITY IS INCLUDED IN THE MASSLINE BALANCE.

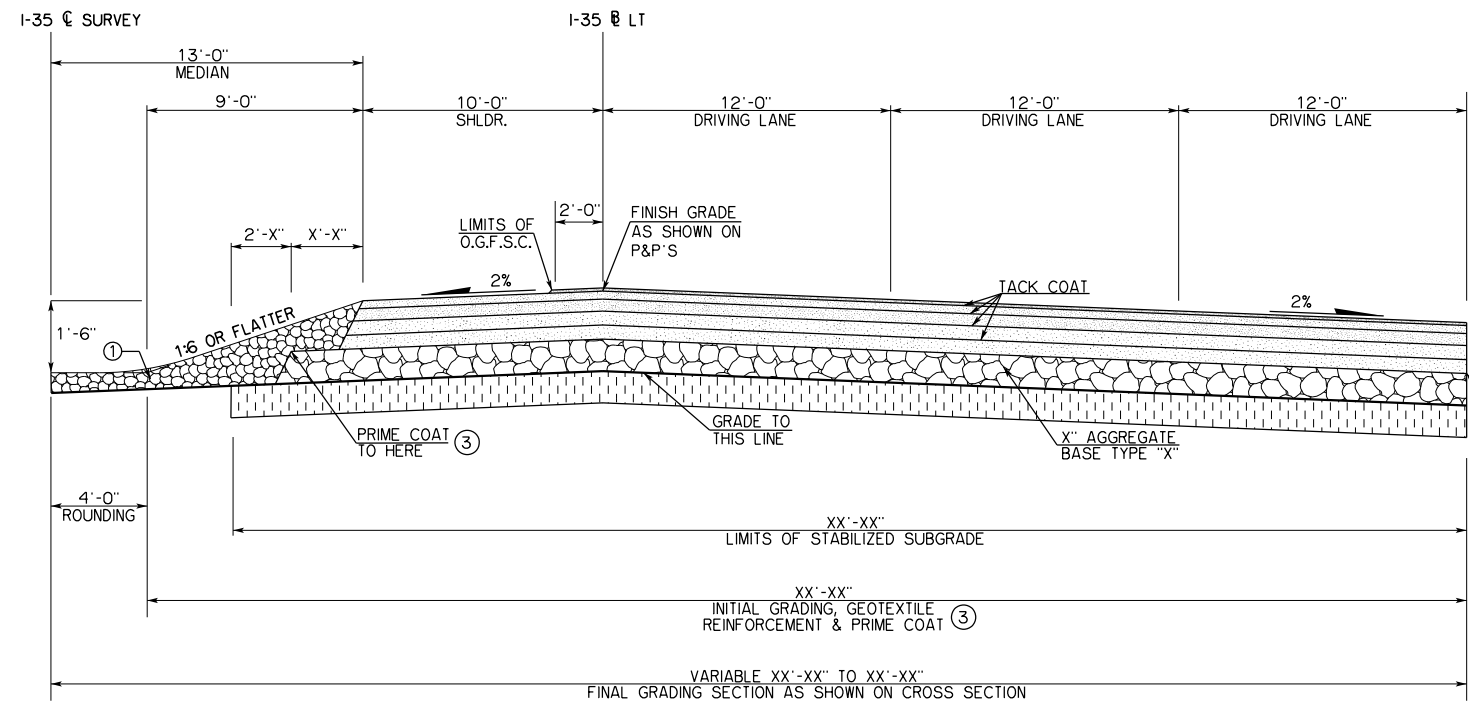

PAVT. STRUCTURE	PAVEMENT REQUIREMENT	
	12'-0" DRIVING LANES	10'-0" SHOULDERS
SURFACE COURSE	O.G.F.S.C 2" ON SHOULDERS COVERING ALL DRIVING LANES	
BASE COURSE	X" SUPERPAVE TYPE S4 (PG 76-28 OK)	X" SUPERPAVE TYPE S4 (PG 64-22 OK)
	X" SUPERPAVE TYPE S3 (PG 76-28 OK)	X" SUPERPAVE TYPE S3 (PG 64-22 OK)
	X" SUPERPAVE TYPE S3 (PG 64-22 OK)	X" SUPERPAVE TYPE S3 (PG 64-22 OK)
	X" SUPERPAVE TYPE S3 (PG 64-22 OK)	X" SUPERPAVE TYPE S3 (PG 64-22 OK)

TYPICAL SECTION NO. 8
1-35 @ RT
STA. 3019+50.00 TO STA. 3022+17.54
STA. 3034+65.34 TO STA. 3035+50.00

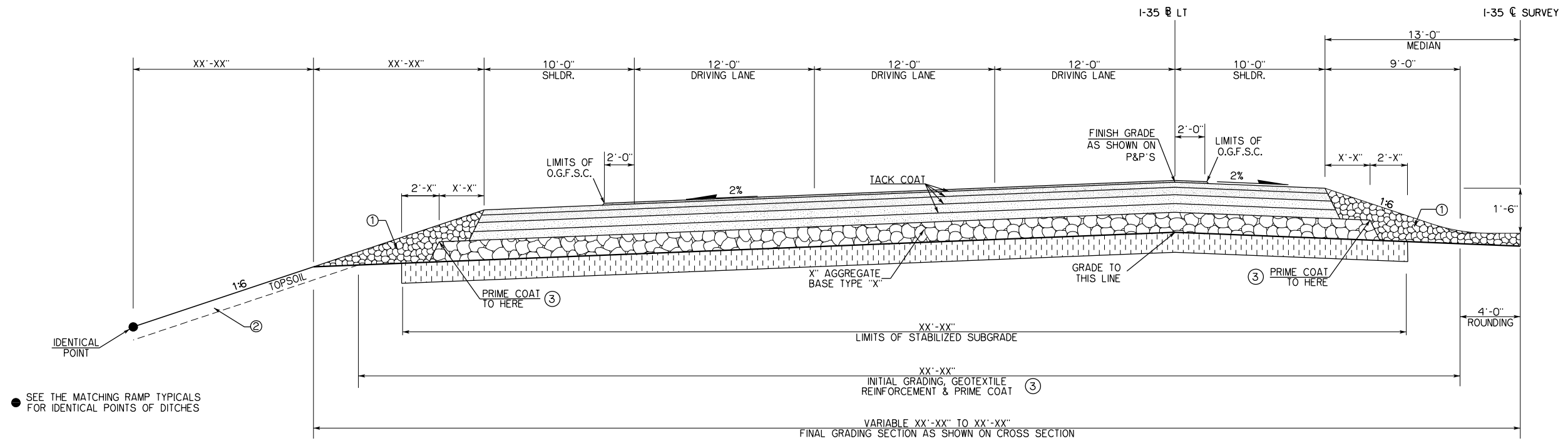

● SEE THE MATCHING RAMP TYPICALS FOR IDENTICAL POINTS OF DITCHES

PAVT. STRUCTURE	PAVEMENT REQUIREMENT	
	12'-0" DRIVING LANES	10'-0" SHOULDERS
SURFACE COURSE	O.G.F.S.C 2" ON SHOULDERS COVERING ALL DRIVING LANES	
BASE COURSE	X" SUPERPAVE TYPE S4 (PG 76-28 OK)	X" SUPERPAVE TYPE S4 (PG 64-22 OK)
	X" SUPERPAVE TYPE S3 (PG 76-28 OK)	X" SUPERPAVE TYPE S3 (PG 64-22 OK)
	X" SUPERPAVE TYPE S3 (PG 64-22 OK)	X" SUPERPAVE TYPE S3 (PG 64-22 OK)
	X" SUPERPAVE TYPE S3 (PG 64-22 OK)	X" SUPERPAVE TYPE S3 (PG 64-22 OK)

TYPICAL SECTION NO. 9
1-35 @ LT
STA. 3020+15.19 TO STA. 3026+21.50
STA. 3029+01.50 TO STA. 3035+50.00

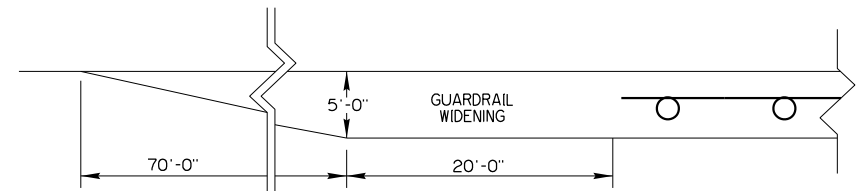

GUARDRAIL WIDENING TYPICAL
15'-0" TO 15'-0" STA. 3029+01.50 TO STA. 3031+74.63 LT. & RT.
15'-0" TO 10'-0" STA. 3031+74.63 TO STA. 3032+43.79 LT. & RT.

USE STANDARD GHW1-1 CURRENT VERSION DETAIL OF "SHOULDER WIDENING FOR STANDARD GUARDRAIL" FOR MORE INFORMATION

- ① BACKFILL NOTE:
TO BE BACKFILLED AND COMPACTED AS PART OF THE FINISHING OPERATIONS. QUANTITY IS MEASURED AS TBSC.
- ② TOPSOIL NOTE:
THE CONTRACTOR SHALL STRIP ALL OF THE AVAILABLE TOPSOIL, STOCKPILE IT, AND PLACE IT BACK ON THE SECTION IN ACCORDANCE WITH SECTION 205 OF THE STANDARD SPECIFICATIONS. RESERVED TOPSOIL SHALL BE SPREAD FIRST ON THE COMPLETED SLOPES OF THE CUT SECTIONS AND THE REMAINDER ON THE COMPLETED FILL SLOPES OR OTHER PRIORITY AREAS LOCATED BY THE ENGINEER. ALL ADDITIONAL COSTS ASSOCIATED WITH OPERATIONS SHALL BE INCLUDED IN THE PAY ITEM SALVAGED TOPSOIL, LUMP SUM.

THE GRADING LINE AS SHOWN ON THE TYPICAL AND CROSS SECTIONS IS TO THE TOP OF THE TOPSOIL. EARTHWORK QUANTITIES WERE NOT ADJUSTED FOR SALVAGE AND THE TOPSOIL QUANTITY IS INCLUDED IN THE MASSLINE BALANCE.
- ③ PRIME COAT ESTIMATED AT 0.35 GAL. PER SQ. YD. ON TOP OF COMPLETED SUBGRADE, AND 0.25 GAL. PER SQ. YD. ON TOP OF AGGREGATE BASE.

I-35 & US-74 INTERCHANGE McCLAIN COUNTY

TYPICAL SECTION
(SHEET 7 OF 14)

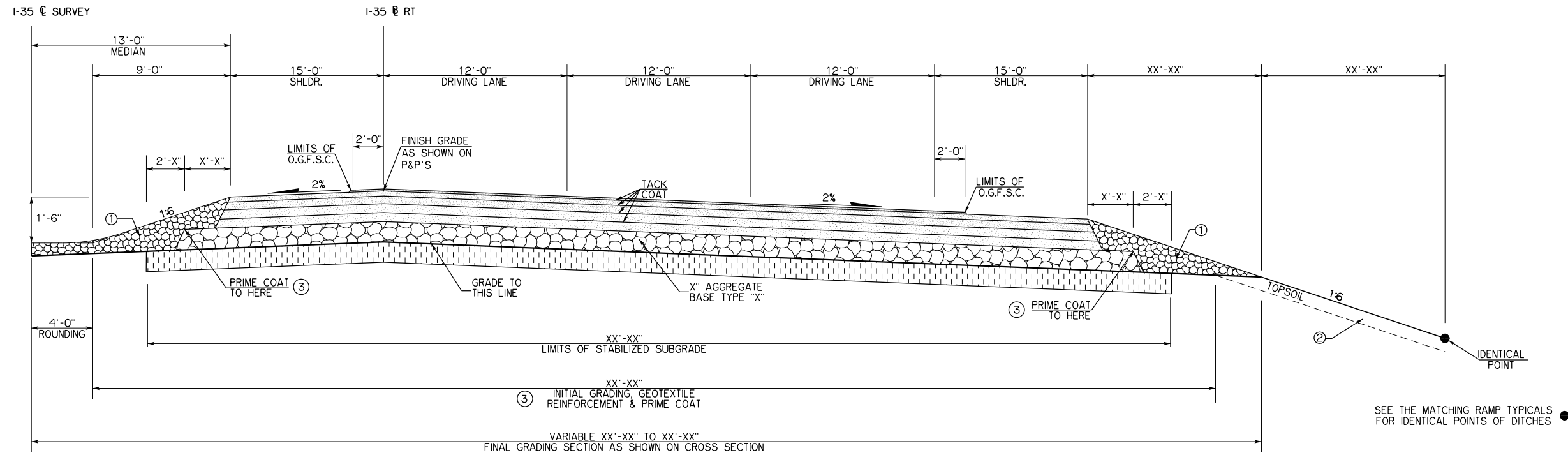

SEE THE MATCHING RAMP TYPICALS FOR IDENTICAL POINTS OF DITCHES

PAVEMENT REQUIREMENT		
PAVT. STRUCTURE	12'-0" DRIVING LANES	10'-0" SHOULDERS
SURFACE COURSE	O.G.F.S.C 2" ON SHOULDERS COVERING ALL DRIVING LANES	
BASE COURSE	X" SUPERPAVE TYPE S4 (PG 76-28 OK)	X" SUPERPAVE TYPE S4 (PG 64-22 OK)
	X" SUPERPAVE TYPE S3 (PG 76-28 OK)	X" SUPERPAVE TYPE S3 (PG 64-22 OK)
	X" SUPERPAVE TYPE S3 (PG 64-22 OK)	X" SUPERPAVE TYPE S3 (PG 64-22 OK)
	X" SUPERPAVE TYPE S3 (PG 64-22 OK)	X" SUPERPAVE TYPE S3 (PG 64-22 OK)

TYPICAL SECTION NO. 10
1-35 B RT
STA. 3020+15.19 TO STA. 3026+21.50
STA. 3029+01.50 TO STA. 3035+50.00

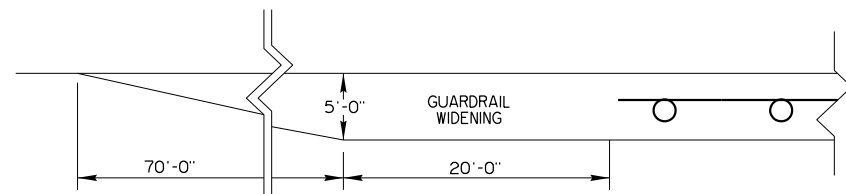

GUARDRAIL WIDENING TYPICAL

10'-0" TO 15'-0"	STA. 3022+88.38 TO STA. 3023+58.38 LT. & RT.
15'-0" TO 15'-0"	STA. 3023+58.38 TO STA. 3026+21.50 LT. & RT.
15'-0" TO 15'-0"	STA. 3029+01.50 TO STA. 3031+20.00 RT.
15'-0" TO 10'-0"	STA. 3031+20.00 TO STA. 3031+90.00 RT.

USE STANDARD GHW1-1 CURRENT VERSION DETAIL OF "SHOULDER WIDENING FOR STANDARD GUARDRAIL" FOR MORE INFORMATION

- ① BACKFILL NOTE:
TO BE BACKFILLED AND COMPACTED AS PART OF THE FINISHING OPERATIONS. QUANTITY IS MEASURED AS TBSC.
- ② TOPSOIL NOTE:
THE CONTRACTOR SHALL STRIP ALL OF THE AVAILABLE TOPSOIL, STOCKPILE IT, AND PLACE IT BACK ON THE SECTION IN ACCORDANCE WITH SECTION 205 OF THE STANDARD SPECIFICATIONS. RESERVED TOPSOIL SHALL BE SPREAD FIRST ON THE COMPLETED SLOPES OF THE CUT SECTIONS AND THE REMAINDER ON THE COMPLETED FILL SLOPES OR OTHER PRIORITY AREAS LOCATED BY THE ENGINEER. ALL ADDITIONAL COSTS ASSOCIATED WITH OPERATIONS SHALL BE INCLUDED IN THE PAY ITEM SALVAGED TOPSOIL, LUMP SUM.

THE GRADING LINE AS SHOWN ON THE TYPICAL AND CROSS SECTIONS IS TO THE TOP OF THE TOPSOIL. EARTHWORK QUANTITIES WERE NOT ADJUSTED FOR SALVAGE AND THE TOPSOIL QUANTITY IS INCLUDED IN THE MASSLINE BALANCE.
- ③ PRIME COAT ESTIMATED AT 0.35 GAL. PER SQ. YD. ON TOP OF COMPLETED SUBGRADE, AND 0.25 GAL. PER SQ. YD. ON TOP OF AGGREGATE BASE.

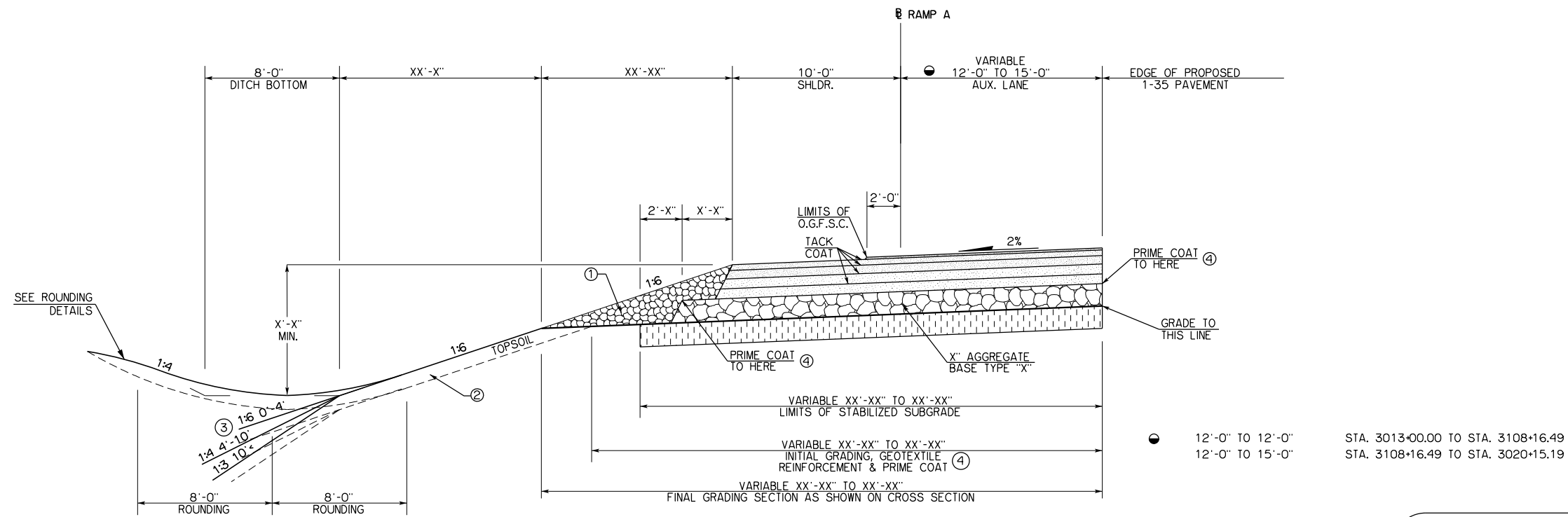

PAVEMENT REQUIREMENT		
PAVT. STRUCTURE	12'-0" TO 15'-0" VAR. DRIVING LANE	10'-0" SHOULDER
SURFACE COURSE	O.G.F.S.C 2" ON SHOULDERS COVERING ALL DRIVING LANES	
BASE COURSE	X" SUPERPAVE TYPE S4 (PG 76-28 OK)	X" SUPERPAVE TYPE S4 (PG 76-28 OK)
	X" SUPERPAVE TYPE S3 (PG 76-28 OK)	X" SUPERPAVE TYPE S3 (PG 76-28 OK)
	X" SUPERPAVE TYPE S3 (PG 64-22 OK)	X" SUPERPAVE TYPE S3 (PG 64-22 OK)
	X" SUPERPAVE TYPE S3 (PG 64-22 OK)	X" SUPERPAVE TYPE S3 (PG 64-22 OK)

TYPICAL SECTION NO. 11
RAMP A

STA. 3013+00.00 TO STA. 3020+15.19

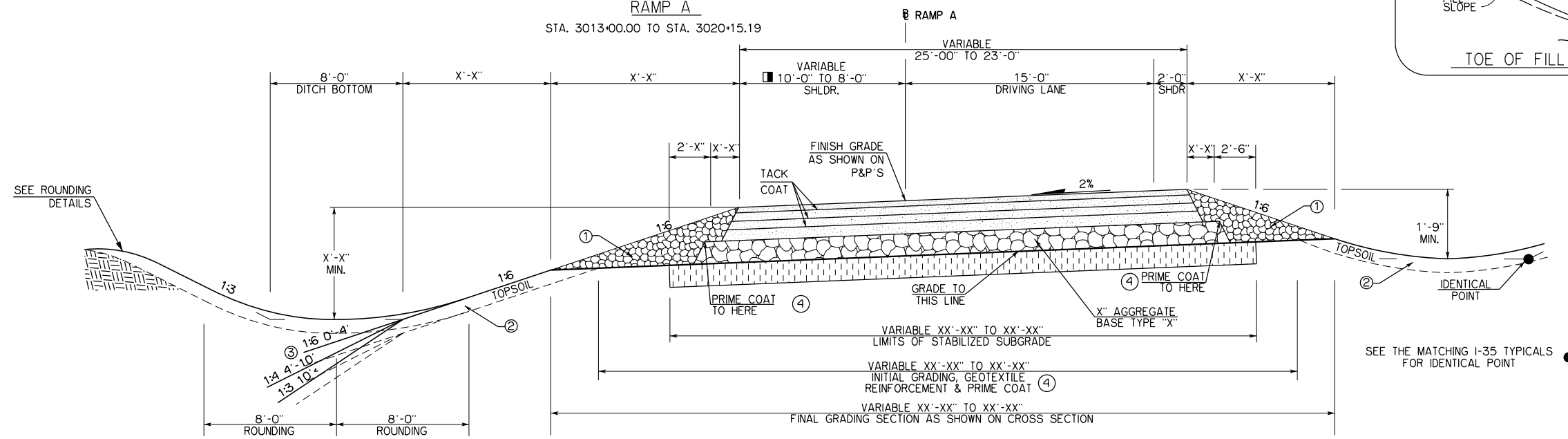

■ 10'-0" TO 8'-0" STA. 3020+15.19 TO STA. 3020+63.93
8'-0" TO 8'-0" STA. 3020+63.93 TO STA. 3027+67.90

PAVEMENT REQUIREMENT		
PAVT. STRUCTURE	15'-0" DRIVING LANE	10'-0" TO 8'-0" VAR & 2'-0" SHOULDER
SURFACE COURSE	X" SUPERPAVE TYPE S4 (PG 76-28 OK)	X" SUPERPAVE TYPE S4 (PG 76-28 OK)
BASE COURSE	X" SUPERPAVE TYPE S3 (PG 76-28 OK)	X" SUPERPAVE TYPE S3 (PG 76-28 OK)
	X" SUPERPAVE TYPE S3 (PG 64-22 OK)	X" SUPERPAVE TYPE S3 (PG 64-22 OK)
	X" SUPERPAVE TYPE S3 (PG 64-22 OK)	X" SUPERPAVE TYPE S3 (PG 64-22 OK)

TYPICAL SECTION NO. 12
RAMP A

STA. 3020+15.19 TO STA. 3027+67.90

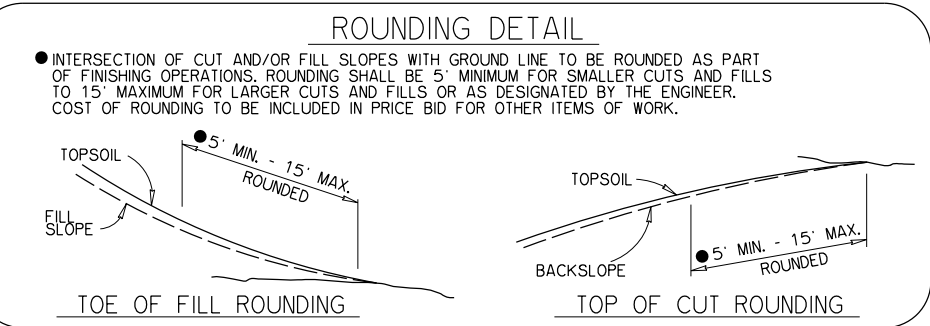

- ① BACKFILL NOTE:
TO BE BACKFILLED AND COMPACTED AS PART OF THE FINISHING OPERATIONS. QUANTITY IS MEASURED AS TBSC.
- ② TOPSOIL NOTE:
THE CONTRACTOR SHALL STRIP ALL OF THE AVAILABLE TOPSOIL, STOCKPILE IT, AND PLACE IT BACK ON THE SECTION IN ACCORDANCE WITH SECTION 205 OF THE STANDARD SPECIFICATIONS. RESERVED TOPSOIL SHALL BE SPREAD FIRST ON THE COMPLETED SLOPES OF THE CUT SECTIONS AND THE REMAINDER ON THE COMPLETED FILL SLOPES OR OTHER PRIORITY AREAS LOCATED BY THE ENGINEER. ALL ADDITIONAL COSTS ASSOCIATED WITH OPERATIONS SHALL BE INCLUDED IN THE PAY ITEM SALVAGED TOPSOIL, LUMP SUM.
- THE GRADING LINE AS SHOWN ON THE TYPICAL AND CROSS SECTIONS IS TO THE TOP OF THE TOPSOIL. EARTHWORK QUANTITIES WERE NOT ADJUSTED FOR SALVAGE AND THE TOPSOIL QUANTITY IS INCLUDED IN THE MASSLINE BALANCE.
- ③ DISTANCE MEASURED VERTICALLY FROM THE EDGE OF FINISHED GRADE SHOULDER.
- ④ PRIME COAT ESTIMATED AT 0.35 GAL. PER SQ. YD. ON TOP OF COMPLETED SUBGRADE, AND 0.25 GAL. PER SQ. YD. ON TOP OF AGGREGATE BASE.

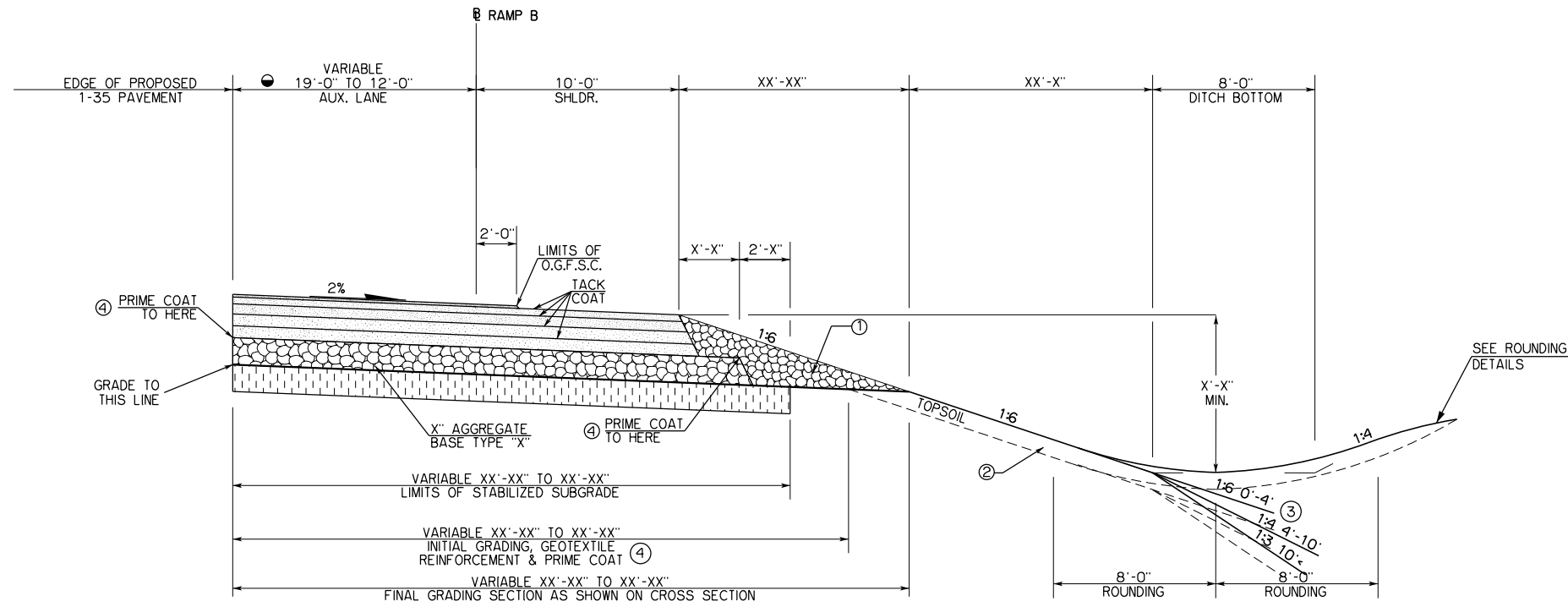

PAVEMENT REQUIREMENT		
PAVT. STRUCTURE	12'-0" TO 19'-0" VAR. DRIVING LANE	10'-0" SHOULDER
SURFACE COURSE	O.G.F.S.C 2" ON SHOULDERS COVERING ALL DRIVING LANES	
BASE COURSE	X" SUPERPAVE TYPE S4 (PG 76-28 OK)	X" SUPERPAVE TYPE S4 (PG 76-28 OK)
	X" SUPERPAVE TYPE S3 (PG 76-28 OK)	X" SUPERPAVE TYPE S3 (PG 76-28 OK)
	X" SUPERPAVE TYPE S3 (PG 64-22 OK)	X" SUPERPAVE TYPE S3 (PG 64-22 OK)
	X" SUPERPAVE TYPE S3 (PG 64-22 OK)	X" SUPERPAVE TYPE S3 (PG 64-22 OK)

TYPICAL SECTION NO. 13

RAMP B

STA. 3009+00.00 TO STA. 3021+59.29

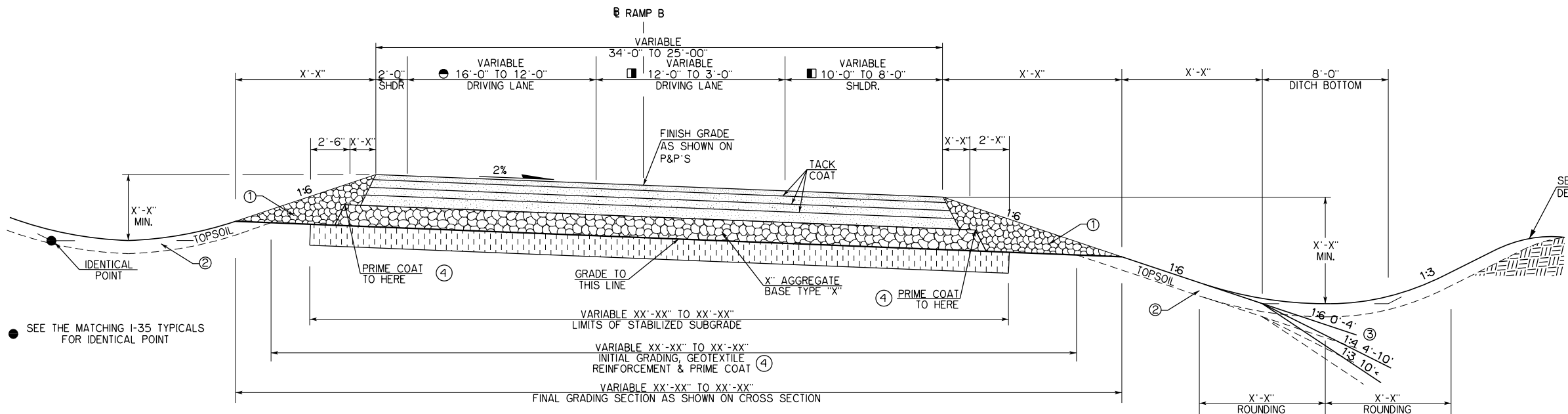

PAVEMENT REQUIREMENT		
PAVT. STRUCTURE	12'-0" TO 15'-0" VAR. DRIVING LANES	10'-0" TO 8'-0" VAR & 2'-0" SHOULDER
SURFACE COURSE	X" SUPERPAVE TYPE S4 (PG 76-28 OK)	X" SUPERPAVE TYPE S4 (PG 76-28 OK)
BASE COURSE	X" SUPERPAVE TYPE S3 (PG 76-28 OK)	X" SUPERPAVE TYPE S3 (PG 76-28 OK)
	X" SUPERPAVE TYPE S3 (PG 64-22 OK)	X" SUPERPAVE TYPE S3 (PG 64-22 OK)
	X" SUPERPAVE TYPE S3 (PG 64-22 OK)	X" SUPERPAVE TYPE S3 (PG 64-22 OK)

TYPICAL SECTION NO. 14

RAMP B

STA. 3021+59.29 TO STA. 3027+48.40

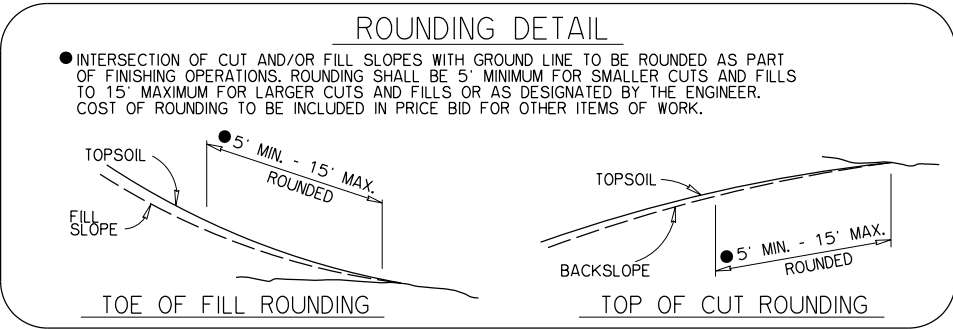

① BACKFILL NOTE:
TO BE BACKFILLED AND COMPACTED AS PART OF THE FINISHING OPERATIONS. QUANTITY IS MEASURED AS TBSC.

② TOPSOIL NOTE:
THE CONTRACTOR SHALL STRIP ALL OF THE AVAILABLE TOPSOIL, STOCKPILE IT, AND PLACE IT BACK ON THE SECTION IN ACCORDANCE WITH SECTION 205 OF THE STANDARD SPECIFICATIONS. RESERVED TOPSOIL SHALL BE SPREAD FIRST ON THE COMPLETED SLOPES OF THE CUT SECTIONS AND THE REMAINDER ON THE COMPLETED FILL SLOPES OR OTHER PRIORITY AREAS LOCATED BY THE ENGINEER. ALL ADDITIONAL COSTS ASSOCIATED WITH OPERATIONS SHALL BE INCLUDED IN THE PAY ITEM SALVAGED TOPSOIL, LUMP SUM.

THE GRADING LINE AS SHOWN ON THE TYPICAL AND CROSS SECTIONS IS TO THE TOP OF THE TOPSOIL. EARTHWORK QUANTITIES WERE NOT ADJUSTED FOR SALVAGE AND THE TOPSOIL QUANTITY IS INCLUDED IN THE MASSLINE BALANCE.

③ DISTANCE MEASURED VERTICALLY FROM THE EDGE OF FINISHED GRADE SHOULDER.

④ PRIME COAT ESTIMATED AT 0.35 GAL. PER SQ. YD. ON TOP OF COMPLETED SUBGRADE, AND 0.25 GAL. PER SQ. YD. ON TOP OF AGGREGATE BASE.

● 16'-0" TO 12'-0" STA. 3022+17.54 TO STA. 3023+58.38
12'-0" TO 12'-0" STA. 3023+58.38 TO STA. 3027+50.06

■ 3'-0" TO 3'-0" STA. 3022+17.54 TO STA. 3023+74.22
3'-0" TO 12'-0" STA. 3023+74.22 TO STA. 3025+09.48
12'-0" TO 12'-0" STA. 3029+09.48 TO STA. 3027+50.06

■ 10'-0" TO 8'-0" STA. 3022+17.54 TO STA. 3023+15.69
8'-0" TO 8'-0" STA. 3023+15.69 TO STA. 3027+50.06

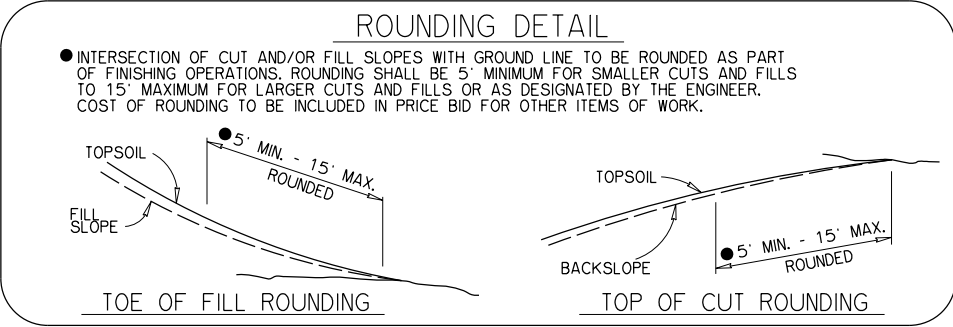
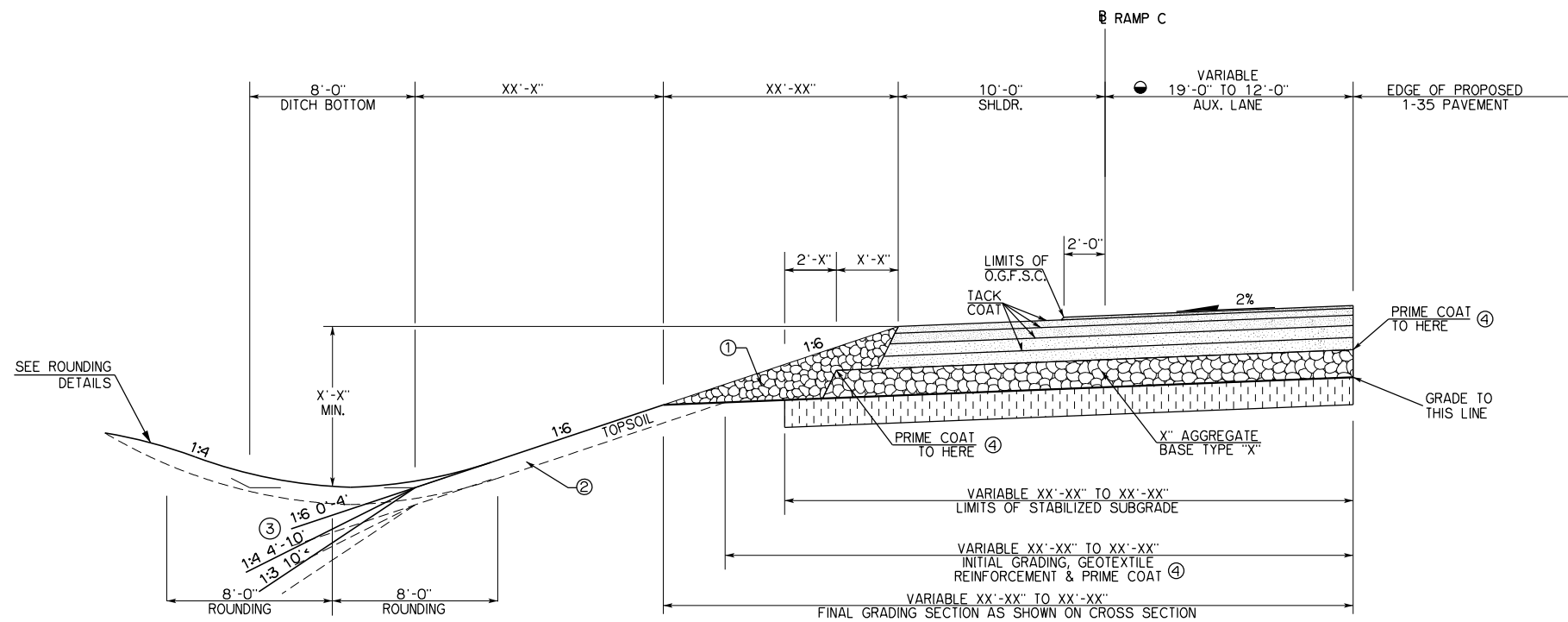

PAVEMENT REQUIREMENT		
PAVT. STRUCTURE	12'-0" TO 19'-0" VAR. DRIVING LANE	10'-0" SHOULDER
SURFACE COURSE	O.G.F.S.C 2" ON SHOULDERS COVERING ALL DRIVING LANES	
BASE COURSE	X" SUPERPAVE TYPE S4 (PG 76-28 OK)	X" SUPERPAVE TYPE S4 (PG 76-28 OK)
	X" SUPERPAVE TYPE S3 (PG 76-28 OK)	X" SUPERPAVE TYPE S3 (PG 76-28 OK)
	X" SUPERPAVE TYPE S3 (PG 64-22 OK)	X" SUPERPAVE TYPE S3 (PG 64-22 OK)
	X" SUPERPAVE TYPE S3 (PG 64-22 OK)	X" SUPERPAVE TYPE S3 (PG 64-22 OK)

● 19'-0" TO 12'-0" STA. 3036+10.20 TO STA. 3038+62.83
 ● 12'-0" TO 12'-0" STA. 3038+62.83 TO STA. 3047+00.00

TYPICAL SECTION NO. 15
RAMP C

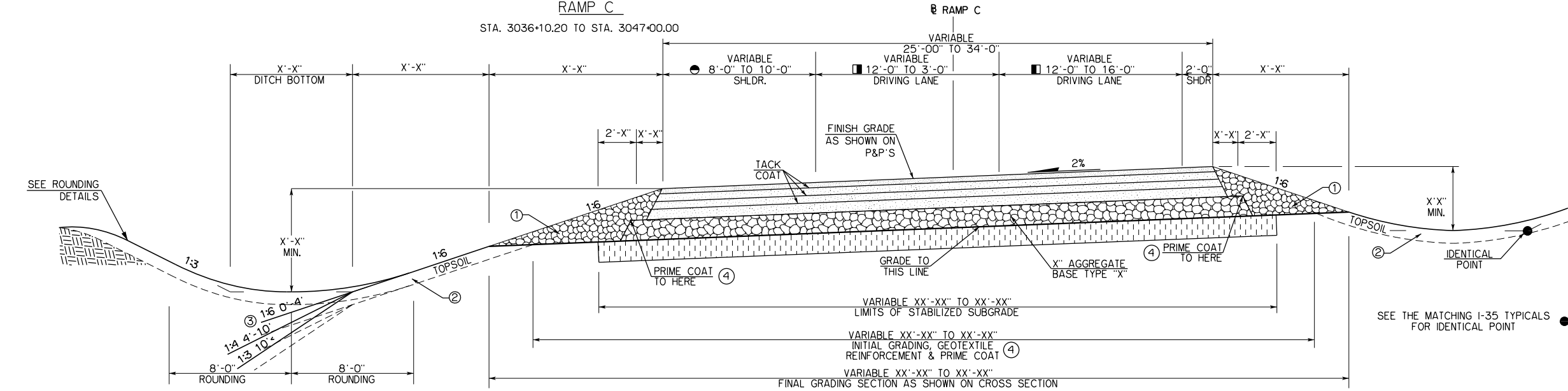

PAVEMENT REQUIREMENT		
PAVT. STRUCTURE	3'-0" TO 16'-0" VAR. DRIVING LANES	10'-0" TO 8'-0" VAR & 2'-0" SHOULDER
SURFACE COURSE	X" SUPERPAVE TYPE S4 (PG 76-28 OK)	
BASE COURSE	X" SUPERPAVE TYPE S4 (PG 76-28 OK)	X" SUPERPAVE TYPE S4 (PG 76-28 OK)
	X" SUPERPAVE TYPE S3 (PG 76-28 OK)	X" SUPERPAVE TYPE S3 (PG 76-28 OK)
	X" SUPERPAVE TYPE S3 (PG 64-22 OK)	X" SUPERPAVE TYPE S3 (PG 64-22 OK)
	X" SUPERPAVE TYPE S3 (PG 64-22 OK)	X" SUPERPAVE TYPE S3 (PG 64-22 OK)

● 8'-0" TO 8'-0" STA. 3027+58.16 TO STA. 3035+12.13
 ● 8'-0" TO 10'-0" STA. 3035+12.13 TO STA. 3036+10.20

■ 12'-0" TO 12'-0" STA. 3027+58.16 TO STA. 3031+55.55
 ■ 12'-0" TO 3'-0" STA. 3031+55.55 TO STA. 3032+90.55
 ■ 3'-0" TO 3'-0" STA. 3032+90.55 TO STA. 3036+10.20

■ 12'-0" TO 12'-0" STA. 3027+58.16 TO STA. 3035+12.23
 ■ 12'-0" TO 16'-0" STA. 3035+12.23 TO STA. 3036+10.20

- ① BACKFILL NOTE: TO BE BACKFILLED AND COMPACTED AS PART OF THE FINISHING OPERATIONS. QUANTITY IS MEASURED AS TBSC.
- ② TOPSOIL NOTE: THE CONTRACTOR SHALL STRIP ALL OF THE AVAILABLE TOPSOIL, STOCKPILE IT, AND PLACE IT BACK ON THE SECTION IN ACCORDANCE WITH SECTION 205 OF THE STANDARD SPECIFICATIONS. RESERVED TOPSOIL SHALL BE SPREAD FIRST ON THE COMPLETED SLOPES OF THE CUT SECTIONS AND THE REMAINDER ON THE COMPLETED FILL SLOPES OR OTHER PRIORITY AREAS LOCATED BY THE ENGINEER. ALL ADDITIONAL COSTS ASSOCIATED WITH OPERATIONS SHALL BE INCLUDED IN THE PAY ITEM SALVAGED TOPSOIL, LUMP SUM.
- ③ DISTANCE MEASURED VERTICALLY FROM THE EDGE OF FINISHED GRADE SHOULDER.
- ④ PRIME COAT ESTIMATED AT 0.35 GAL. PER SQ. YD. ON TOP OF COMPLETED SUBGRADE, AND 0.25 GAL. PER SQ. YD. ON TOP OF AGGREGATE BASE.

TYPICAL SECTION NO. 16
RAMP C

STA. 3027+58.16 TO STA. 3036+10.20

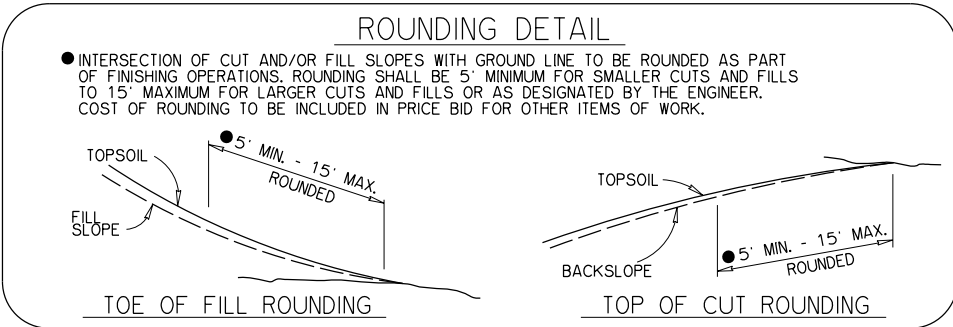
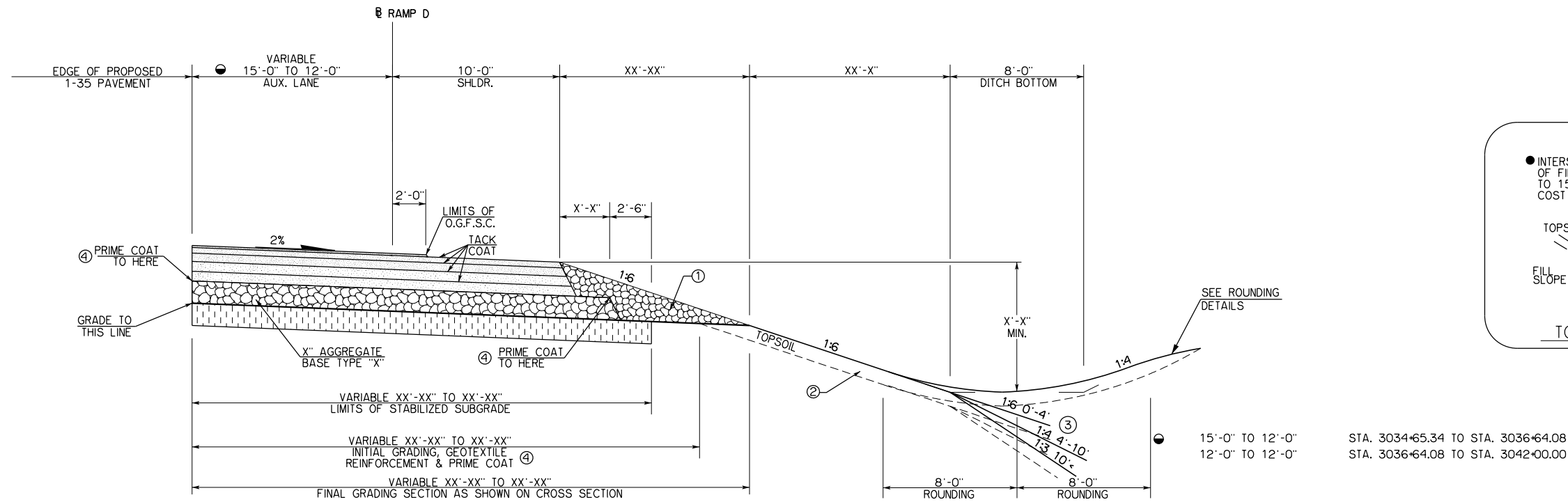

PAVEMENT REQUIREMENT		
PAVT. STRUCTURE	12'-0" TO 15'-0" VAR. DRIVING LANE	10'-0" SHOULDER
SURFACE COURSE	O.G.F.S.C 2' ON SHOULDERS COVERING ALL DRIVING LANES	
BASE COURSE	X" SUPERPAVE TYPE S4 (PG 76-28 OK)	X" SUPERPAVE TYPE S4 (PG 76-28 OK)
	X" SUPERPAVE TYPE S3 (PG 76-28 OK)	X" SUPERPAVE TYPE S3 (PG 76-28 OK)
	X" SUPERPAVE TYPE S3 (PG 64-22 OK)	X" SUPERPAVE TYPE S3 (PG 64-22 OK)
	X" SUPERPAVE TYPE S3 (PG 64-22 OK)	X" SUPERPAVE TYPE S3 (PG 64-22 OK)

TYPICAL SECTION NO. 17

RAMP D

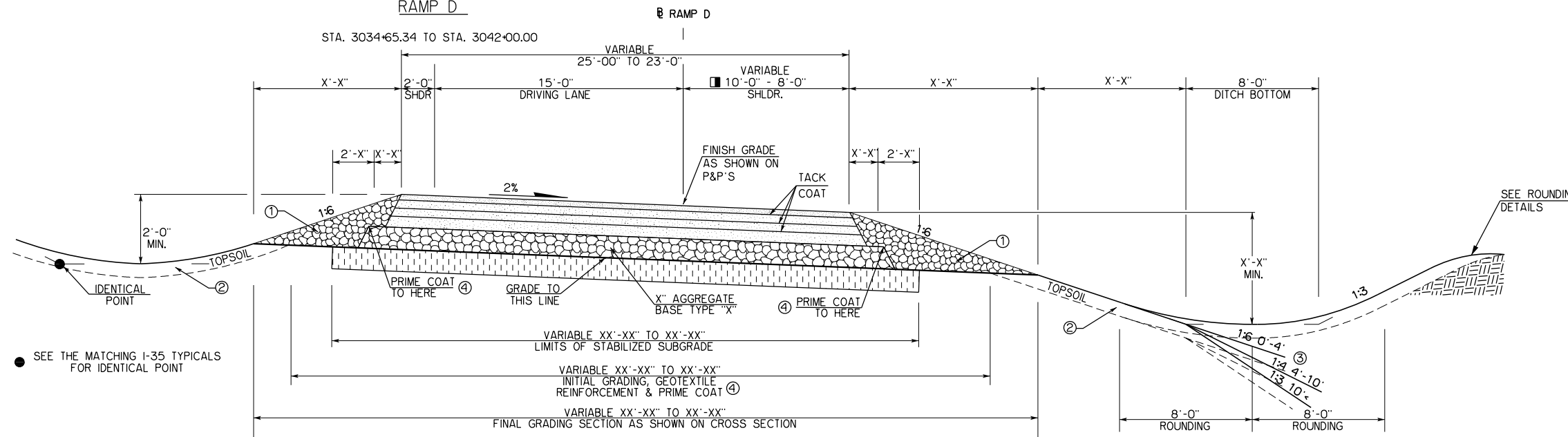

■ 8'-0" TO 8'-0" STA. 3027+72.20 TO STA. 3034+16.17
8'-0" TO 10'-0" STA. 3034+16.17 TO STA. 3034+65.34

PAVEMENT REQUIREMENT		
PAVT. STRUCTURE	15'-0" VAR. DRIVING LANE	10'-0" TO 8'-0" VAR & 2'-0" SHOULDER
SURFACE COURSE	X" SUPERPAVE TYPE S4 (PG 76-28 OK)	X" SUPERPAVE TYPE S4 (PG 76-28 OK)
BASE COURSE	X" SUPERPAVE TYPE S3 (PG 76-28 OK)	X" SUPERPAVE TYPE S3 (PG 76-28 OK)
	X" SUPERPAVE TYPE S3 (PG 64-22 OK)	X" SUPERPAVE TYPE S3 (PG 64-22 OK)
	X" SUPERPAVE TYPE S3 (PG 64-22 OK)	X" SUPERPAVE TYPE S3 (PG 64-22 OK)

TYPICAL SECTION NO. 18
RAMP D

STA. 3027+72.20 TO STA. 3034+65.34

- ① BACKFILL NOTE:
TO BE BACKFILLED AND COMPACTED AS PART OF THE FINISHING OPERATIONS. QUANTITY IS MEASURED AS TBSC.
- ② TOPSOIL NOTE:
THE CONTRACTOR SHALL STRIP ALL OF THE AVAILABLE TOPSOIL, STOCKPILE IT, AND PLACE IT BACK ON THE SECTION IN ACCORDANCE WITH SECTION 205 OF THE STANDARD SPECIFICATIONS. RESERVED TOPSOIL SHALL BE SPREAD FIRST ON THE COMPLETED SLOPES OF THE CUT SECTIONS AND THE REMAINDER ON THE COMPLETED FILL SLOPES OR OTHER PRIORITY AREAS LOCATED BY THE ENGINEER. ALL ADDITIONAL COSTS ASSOCIATED WITH OPERATIONS SHALL BE INCLUDED IN THE PAY ITEM SALVAGED TOPSOIL, LUMP SUM.
- ③ DISTANCE MEASURED VERTICALLY FROM THE EDGE OF FINISHED GRADE SHOULDER.
- ④ PRIME COAT ESTIMATED AT 0.35 GAL. PER SQ. YD. ON TOP OF COMPLETED SUBGRADE, AND 0.25 GAL. PER SQ. YD. ON TOP OF AGGREGATE BASE.

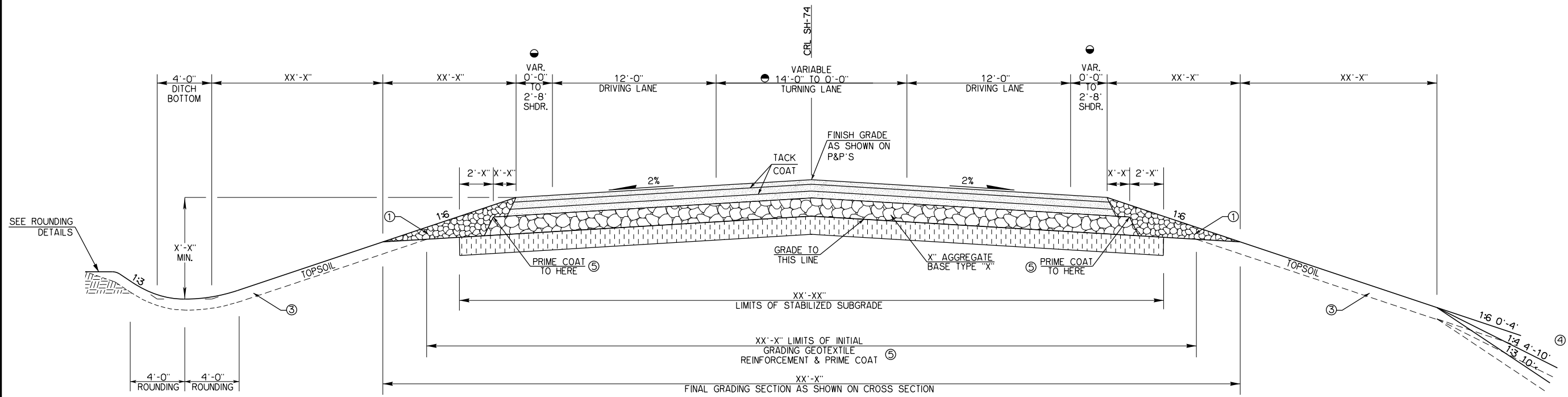

X" PAVT. STRUCTURE	PAVEMENT REQUIREMENT		
	14'-0" TURNING LANES	12'-0" DRIVING LANES	0'-0" TO 2'-8" VAR. SHOULDERS
SURFACE COURSE	X" SUPERPAVE TYPE S4 (PG 64-22 OK)	X" SUPERPAVE TYPE S4 (PG 64-22 OK)	X" SUPERPAVE TYPE S4 (PG 64-22 OK)
BASE COURSE	X" SUPERPAVE TYPE S3 (PG 64-22 OK)	X" SUPERPAVE TYPE S3 (PG 64-22 OK)	X" SUPERPAVE TYPE S3 (PG 64-22 OK)

TYPICAL NO. 19
SH-74
STA. 983+00.00 TO STA. 986+15.00

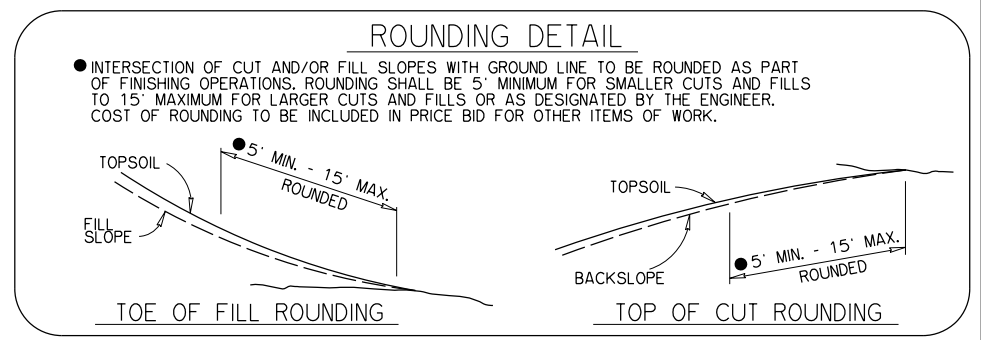

● INTERSECTION OF CUT AND/OR FILL SLOPES WITH GROUND LINE TO BE ROUNDED AS PART OF FINISHING OPERATIONS. ROUNDED SHALL BE 5' MINIMUM FOR SMALLER CUTS AND FILLS TO 15' MAXIMUM FOR LARGER CUTS AND FILLS OR AS DESIGNATED BY THE ENGINEER. COST OF ROUNDED TO BE INCLUDED IN PRICE BID FOR OTHER ITEMS OF WORK.

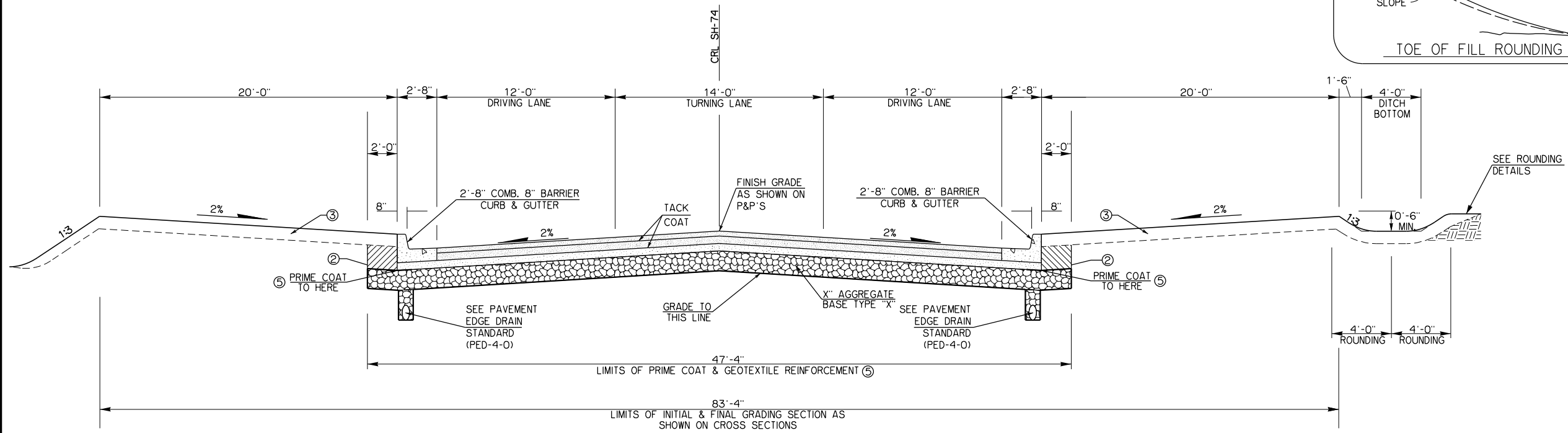

X" PAVT. STRUCTURE	PAVEMENT REQUIREMENT	
	12'-0" DRIVING LANES	14'-0" TURNING LANE
SURFACE COURSE	X" SUPERPAVE TYPE S4 (PG 64-22 OK)	X" SUPERPAVE TYPE S4 (PG 64-22 OK)
BASE COURSE	X" SUPERPAVE TYPE S3 (PG 64-22 OK)	X" SUPERPAVE TYPE S3 (PG 64-22 OK)

TYPICAL NO. 20
SH-74
STA. 986+15.00 TO STA. 1037+67.43

- ① BACKFILL NOTES:
TO BE BACKFILLED AND COMPACTED AS PART OF THE FINISHING OPERATIONS. QUANTITY IS MEASURED AS TBSC.
- ② TO BE BACKFILLED AND COMPACTED AS PART OF THE FINISHING OPERATIONS. QUANTITY IS MEASURED IN UNCLASSIFIED BORROW.
- ③ TOPSOIL NOTE:
THE CONTRACTOR SHALL STRIP ALL OF THE AVAILABLE TOPSOIL, STOCKPILE IT, AND PLACE IT BACK ON THE SECTION IN ACCORDANCE WITH SECTION 205 OF THE STANDARD SPECIFICATIONS. RESERVED TOPSOIL SHALL BE SPREAD FIRST ON THE COMPLETED SLOPES OF THE CUT SECTIONS AND THE REMAINDER ON THE COMPLETED FILL SLOPES OR OTHER PRIORITY AREAS LOCATED BY THE ENGINEER. ALL ADDITIONAL COSTS ASSOCIATED WITH OPERATIONS SHALL BE INCLUDED IN THE PAY ITEM SALVAGED TOPSOIL, LUMP SUM.

THE GRADING LINE AS SHOWN ON THE TYPICAL AND CROSS SECTIONS IS TO THE TOP OF THE TOPSOIL. EARTHWORK QUANTITIES WERE NOT ADJUSTED FOR SALVAGE AND THE TOPSOIL QUANTITY IS INCLUDED IN THE MASSLINE BALANCE.
- ④ DISTANCE MEASURED VERTICALLY FROM THE EDGE OF FINISHED GRADE SHOULDER.
- ⑤ PRIME COAT ESTIMATED AT 0.35 GAL. PER SQ. YD. ON TOP OF COMPLETED SUBGRADE, AND 0.25 GAL. PER SQ. YD. ON TOP OF AGGREGATE BASE.

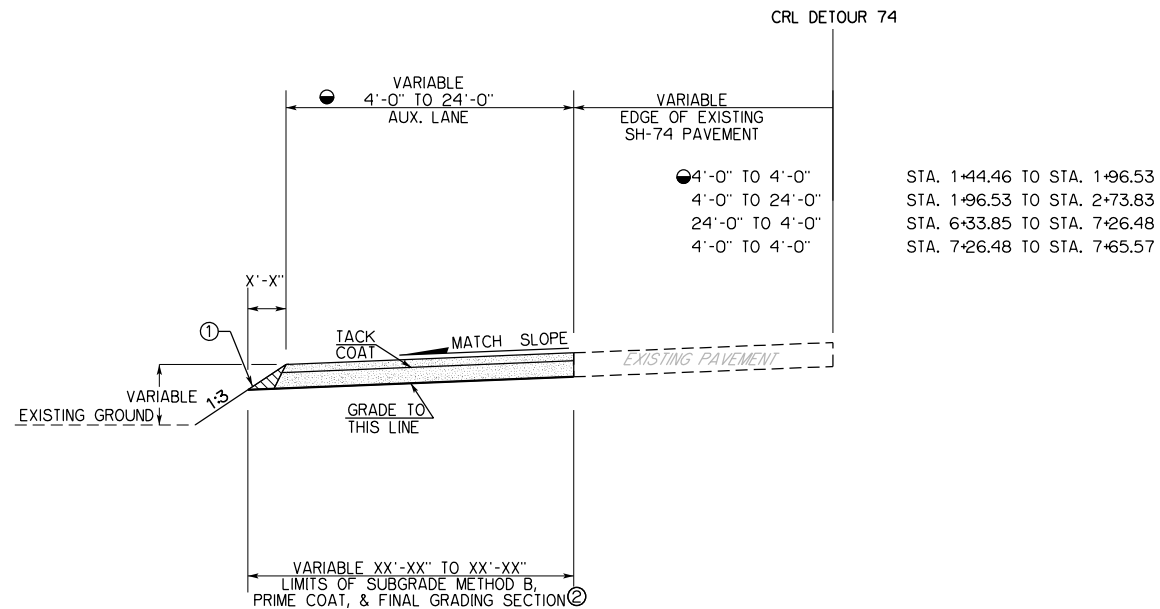

PAVEMENT REQUIREMENT	
PAVT. STRUCTURE	4'-0" TO 24'-0" VAR. DRIVING LANE
SURFACE COURSE	X" SUPERPAVE TYPE S4 (PG 64-22 OK)
BASE COURSE	X" SUPERPAVE TYPE S3 (PG 64-22 OK)

TYPICAL SECTION NO. 21
74 DETOUR

STA. X+XX.XX TO STA. X+XX.XX
STA. X+XX.XX TO STA. X+XX.XX

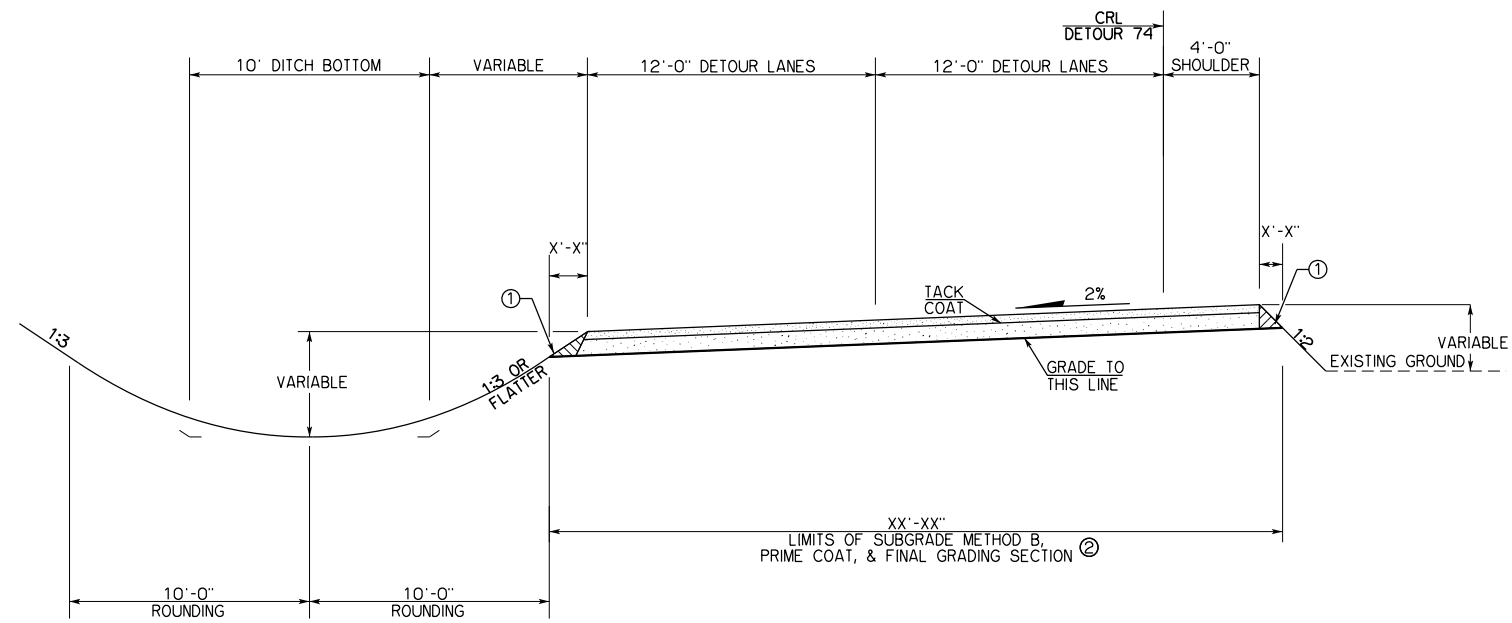

PAVEMENT REQUIREMENT		
PAVT. STRUCTURE	24'-0" DRIVING LANE	4'-0" SHOULDER
SURFACE COURSE	X" SUPERPAVE TYPE S4 (PG 64-22 OK)	X" SUPERPAVE TYPE S4 (PG 64-22 OK)
BASE COURSE	X" SUPERPAVE TYPE S3 (PG 64-22 OK)	X" SUPERPAVE TYPE S3 (PG 64-22 OK)

TYPICAL SECTION NO. 22
74 DETOUR

STA. X+XX.XX TO STA. X+XX.XX

① TO BE BACKFILLED AND COMPACTED AS PART OF THE FINISHING OPERATIONS. QUANTITY IS MEASURED IN UNCLASSIFIED BORROW.

② PRIME COAT THE LIMITS OF THE SUBGRADE AT A RATE OF 0.35 GAL. PER SQ. YD. THE ACTUAL CUTBACK PRIME COAT REQUIRED FOR PLACEMENT OPERATIONS WILL BE DETERMINED BY THE CONTRACTOR.

SEC 2
T-6-N, R-2-W

SEC 35
T-7-N, R-2-W

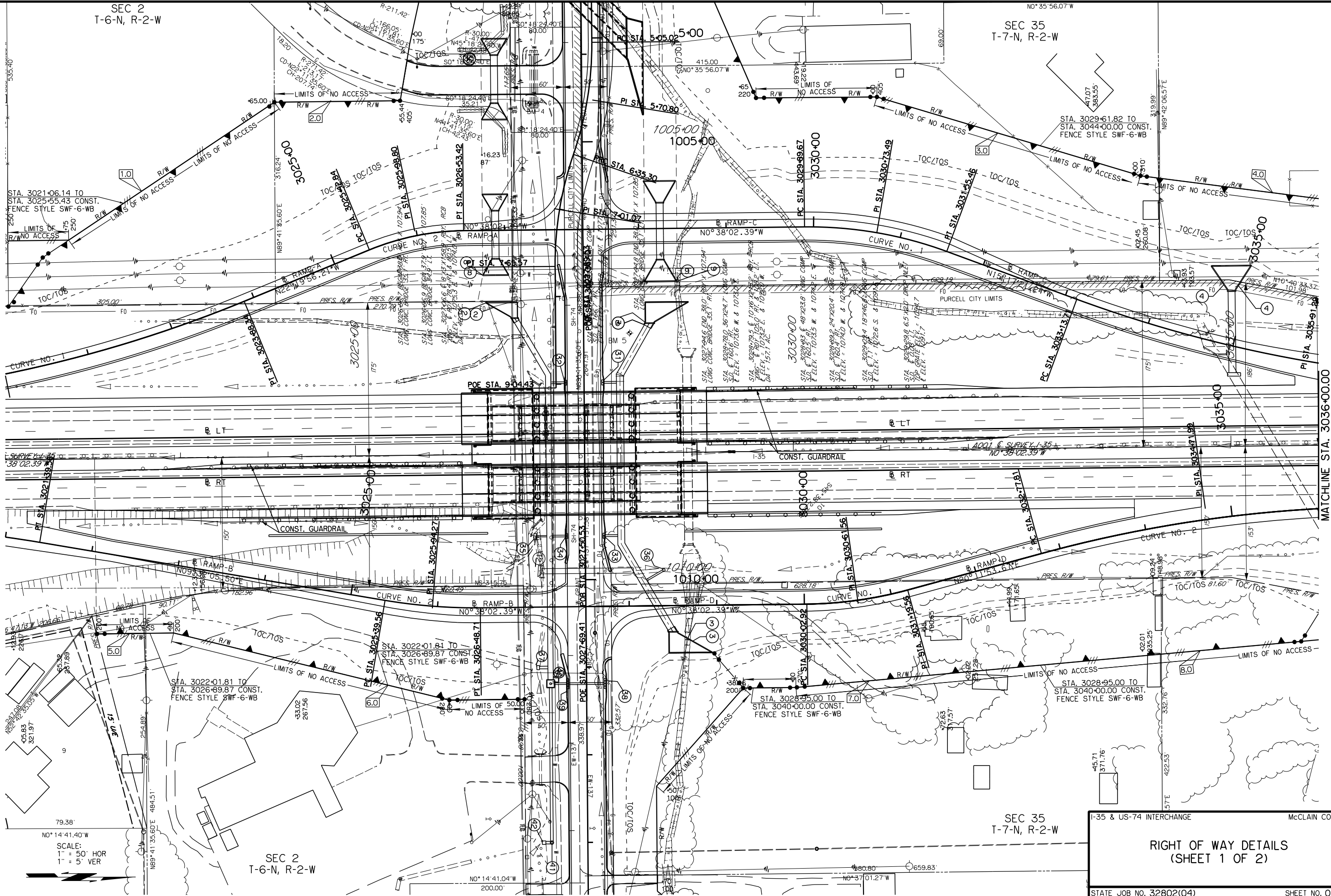

79.38
 N0°14'41.40"W
 SCALE:
 1" = 50' HOR
 1" = 5' VER

SEC 2
T-6-N, R-2-W

SEC 35
T-7-N, R-2-W

I-35 & US-74 INTERCHANGE
 MCCLAIN COUNTY
RIGHT OF WAY DETAILS
 (SHEET 1 OF 2)
 STATE JOB NO. 32802(04) SHEET NO. 0016

SEC 35
T-7-N, R-2-W

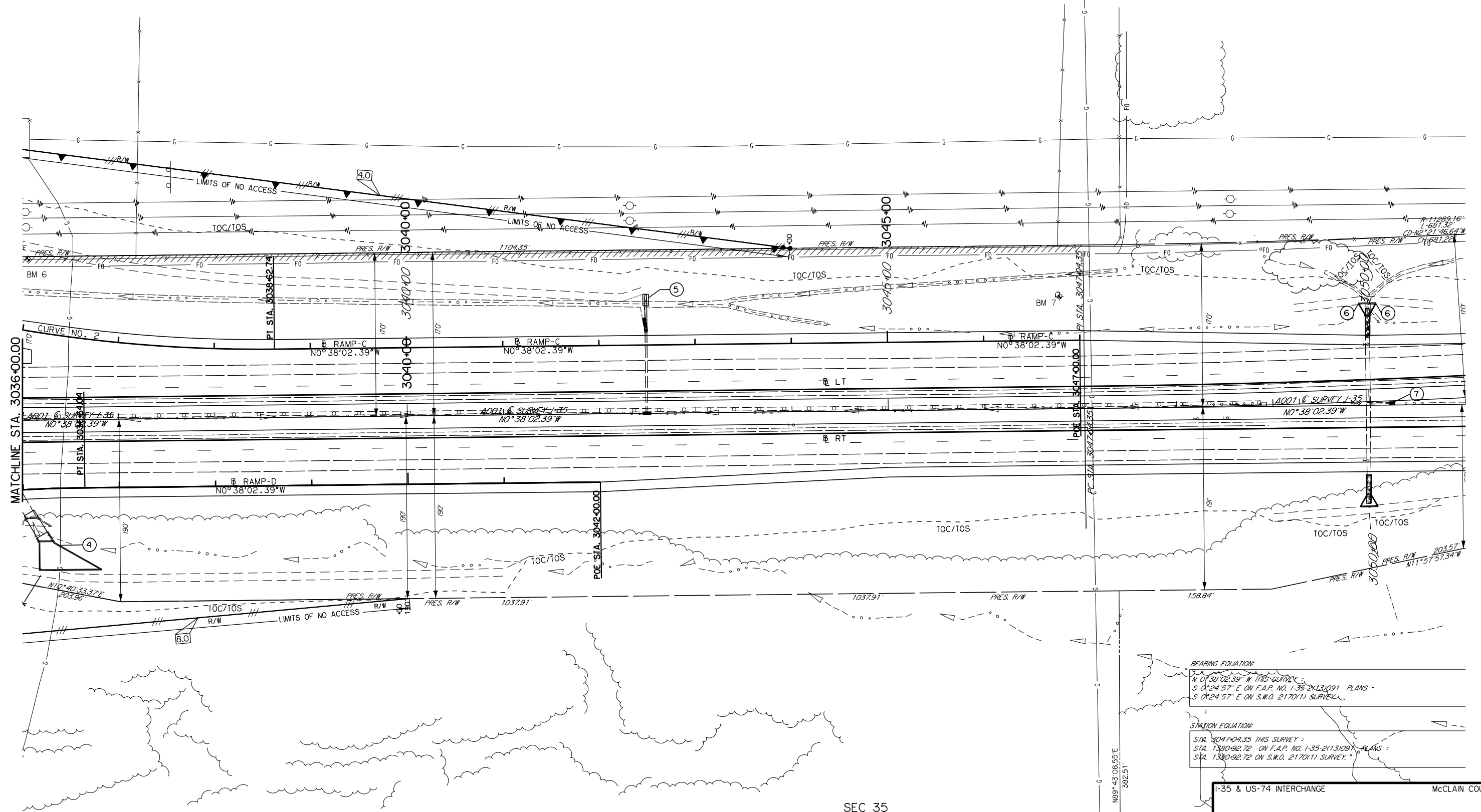

MATCHLINE STA. 3036+00.00

PT STA. 3038+62.74

POE STA. 3042+00.00

PT STA. 3047+00.00

PC STA. 3047+00.00

SCALE:
1" = 50' HOR
1" = 5' VER



BEARING EQUATION:
 N 0° 38' 02.39" W THIS SURVEY =
 S 0° 24' 57" E ON F.A.P. NO. 1-35-2413/091 PLANS =
 S 0° 24' 57" E ON S.W.O. 2170(1) SURVEY.

STATION EQUATION:
 STA. 3047+04.35 THIS SURVEY =
 STA. 1380+92.72 ON F.A.P. NO. 1-35-2113/091 PLANS =
 STA. 1380+92.72 ON S.W.O. 2170(1) SURVEY.

SEC 35
T-7-N, R-2-W

I-35 & US-74 INTERCHANGE McClain County

RIGHT OF WAY DETAILS
(SHEET 2 OF 2)

SECTION 2
T-6-N, R-2-W

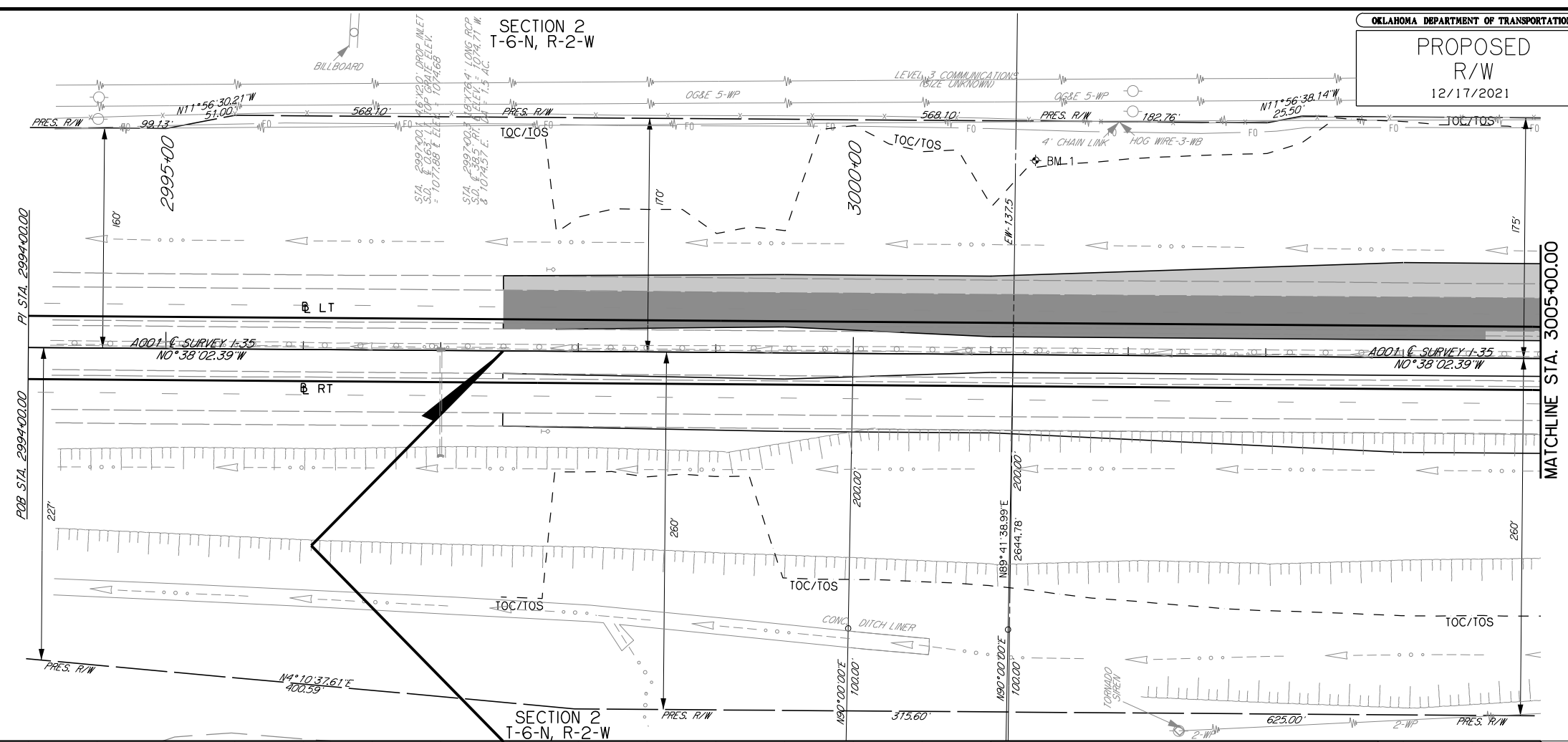

- KEY**
- FULL DEPTH
 - MILL & OVERLAY

SCALE:
1" = 50' HOR
1" = 5' VER

UTILITIES	
COMMUNICATION LINES:	
WINDSTREAM COMM.	405-228-2530
C.T.S.I.	800-927-2027
TRACE FIBER INC.	855-899-8686
COMM. BROOMFIELD CO.	877-453-8353
ELECTRIC LINES:	
OG&E	405-553-5785
CITY OF PURCELL	405-527-6561
SANITARY SEWER:	
CITY OF PURCELL	405-527-6561
WATERLINES:	
CITY OF PURCELL	405-527-6561
PIPELINES:	
ONG OK WEST	405-556-6401

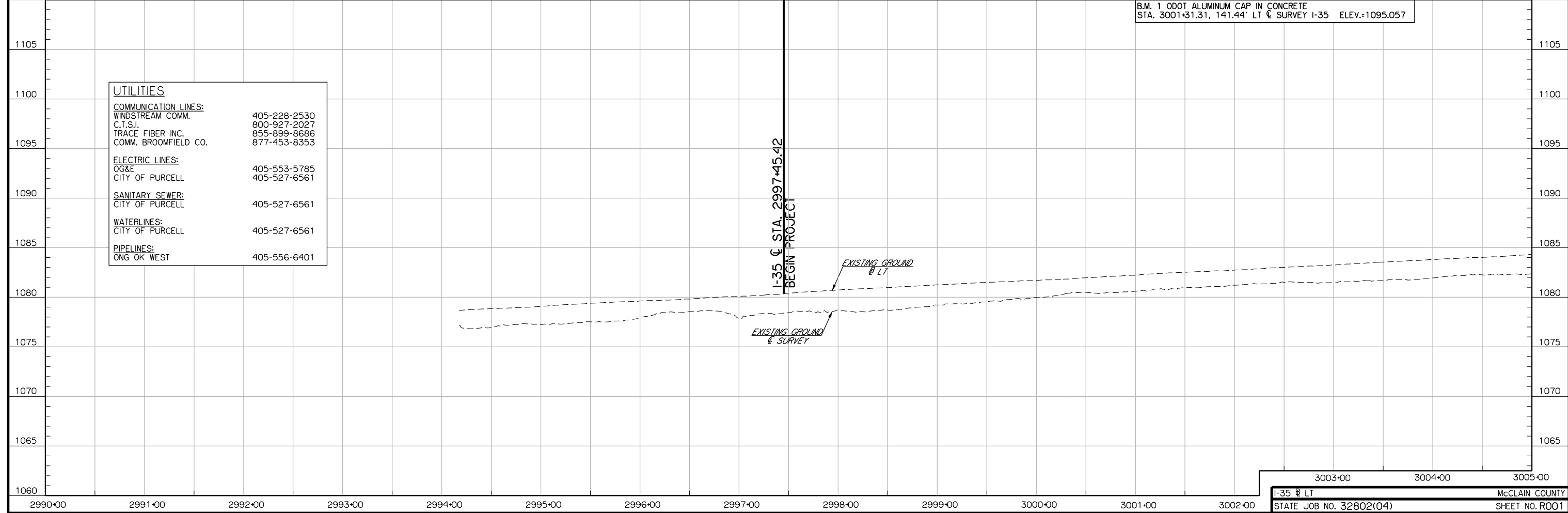

SECTION 2
T-6-N, R-2-W

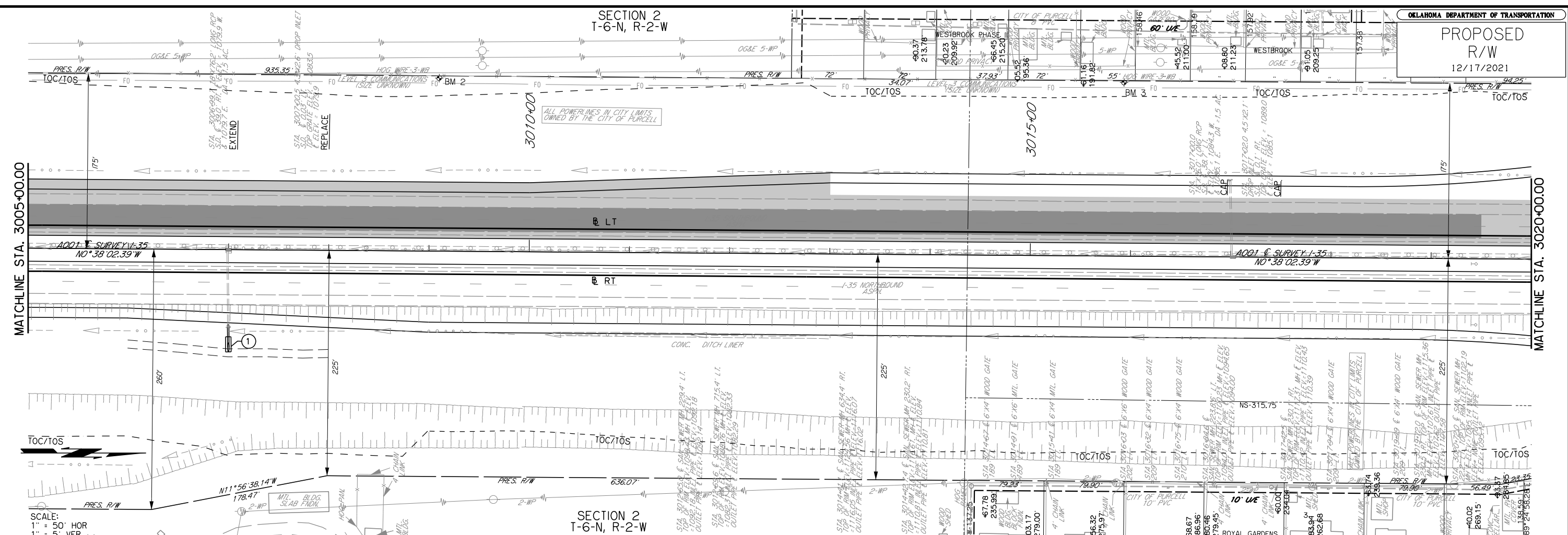

SCALE:
1" = 50' HOR
1" = 5' VER

B.M. 2 TOP OF DELINEATOR POST
STA. 3009+09.89, 173.13' LT \angle SURVEY I-35 ELEV.=1096.009

B.M. 3 RAILROAD SPIKE IN 6" BRACE POST
STA. 3015+91.02, 173.48' LT \angle SURVEY I-35 ELEV.=1103.059

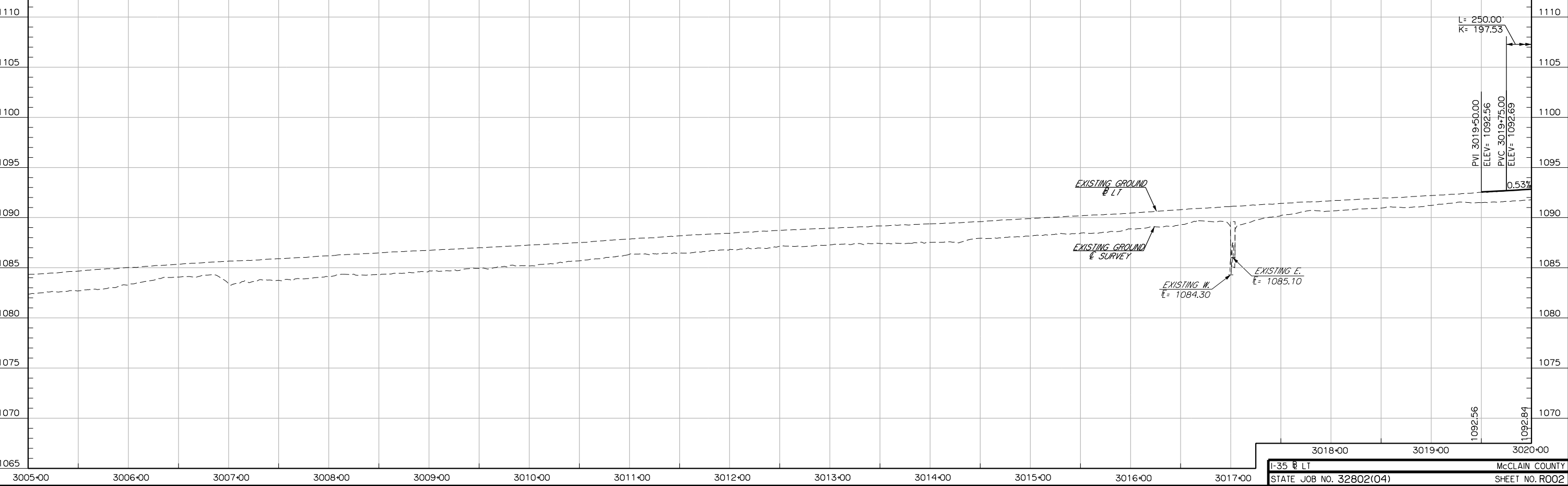

SECTION 35
T-7-N, R-2-W

SECTION 2
T-6-N, R-2-W

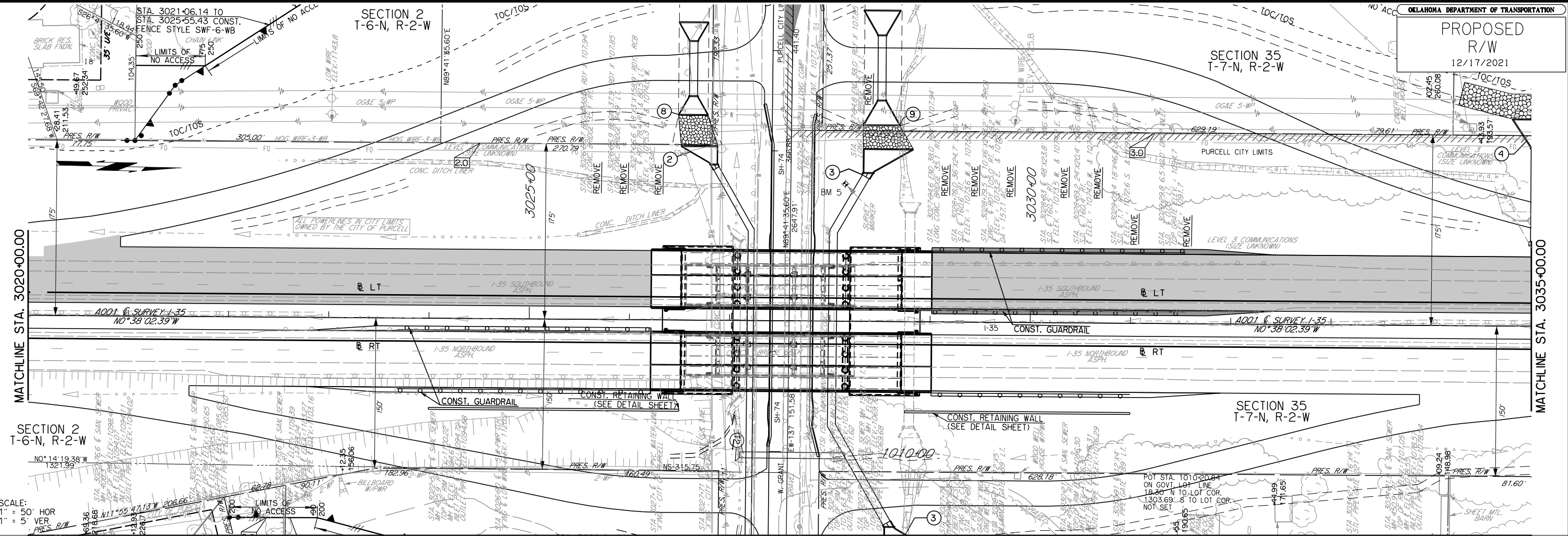

SCALE:
1" = 50' HOR
1" = 5' VER

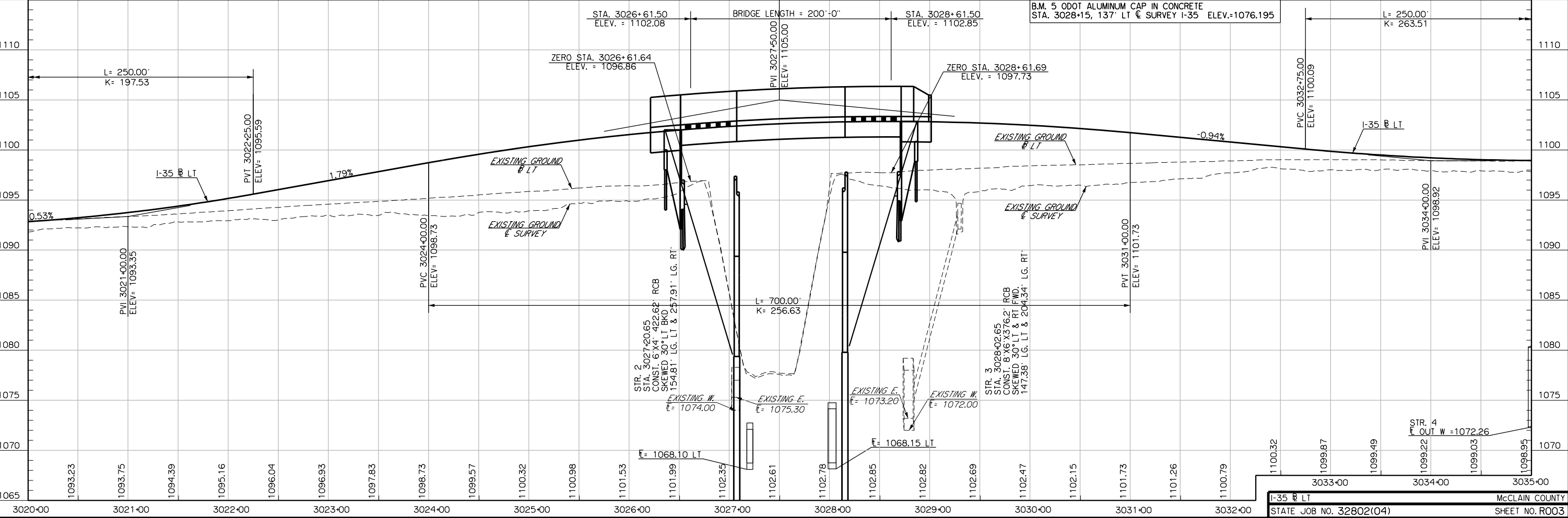

SECTION 35
T-7-N, R-2-W

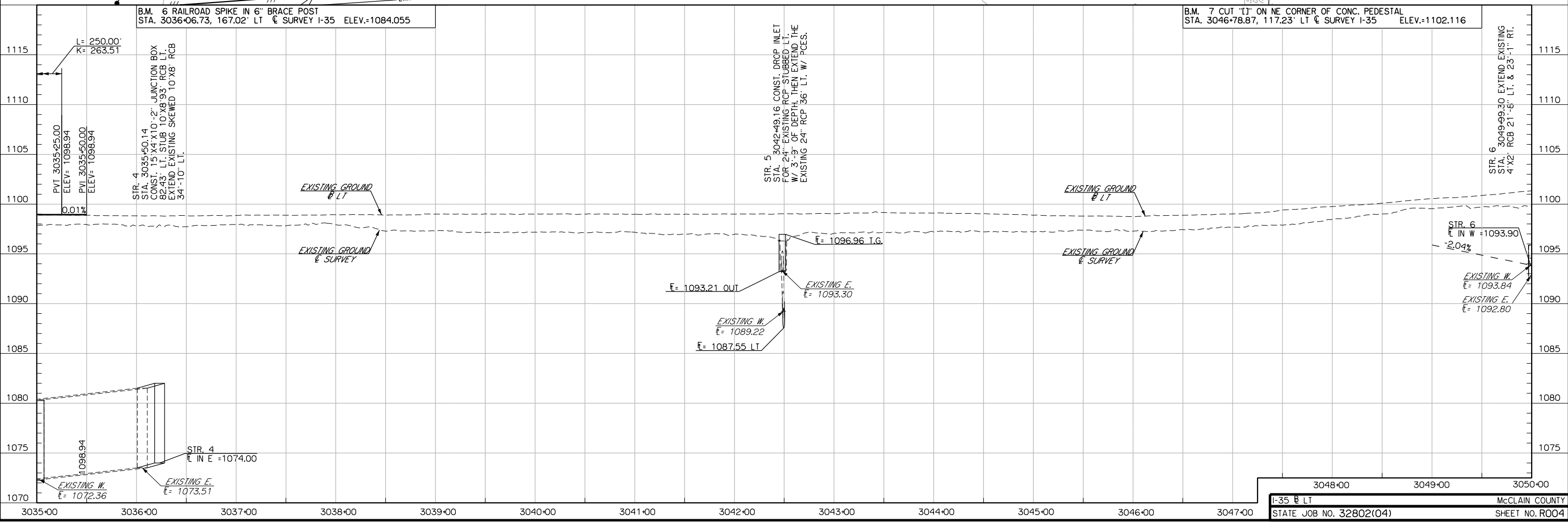
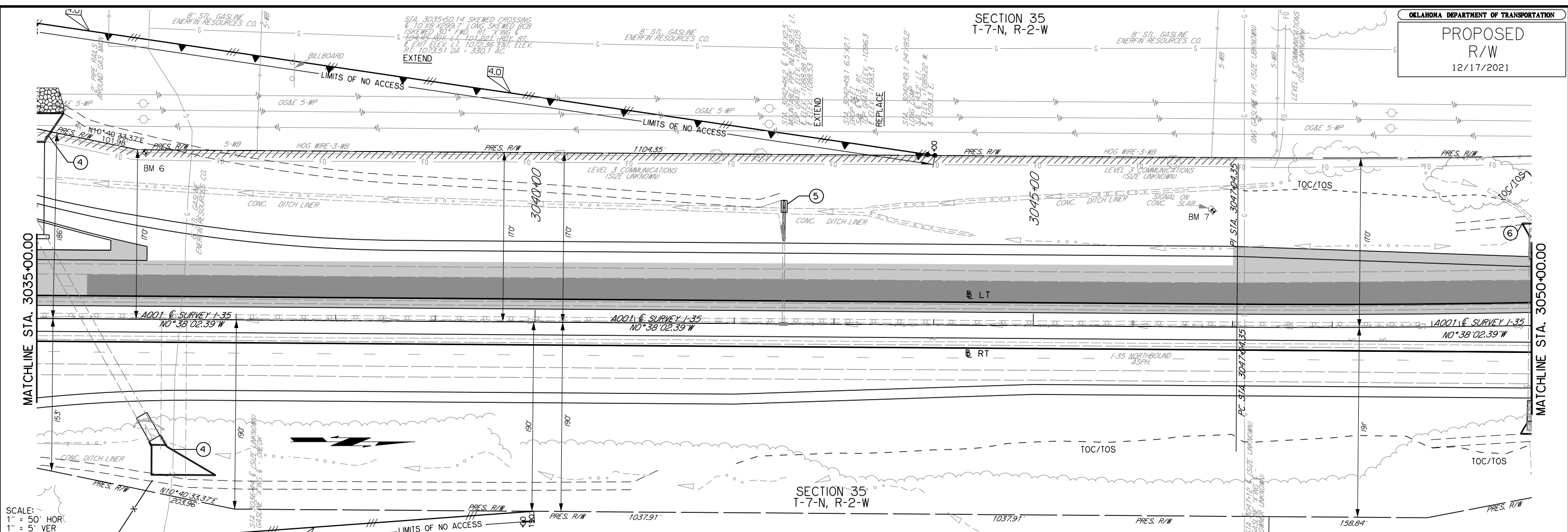

SECTION 35 T-7-N, R-2-W

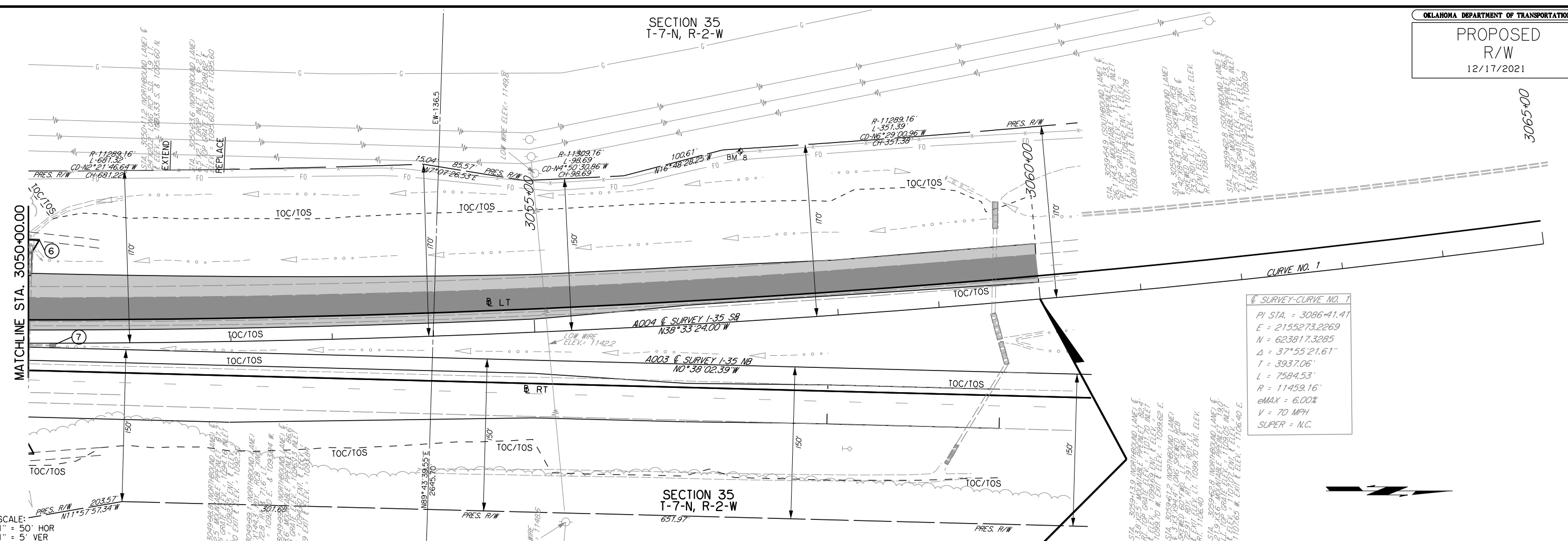

@ SURVEY-CURVE NO. 1
 PI STA. = 3086+41.41
 E = 2155273.2269
 N = 623817.3285
 Δ = 37°55'21.61"
 T = 3937.06'
 L = 7584.53'
 R = 11459.16'
 eMAX = 6.00%
 V = 70 MPH
 SUPER = N.C.



B.M. 6 RAILROAD SPIKE IN 6" BRACE POST
 STA. 3036+06.73, 167.02' LT @ SURVEY I-35 ELEV.=1084.055

B.M. 7 CUT "I" ON NE CORNER OF CONC. PEDESTAL
 STA. 3046+78.87, 117.23' LT @ SURVEY I-35 ELEV.=1102.116

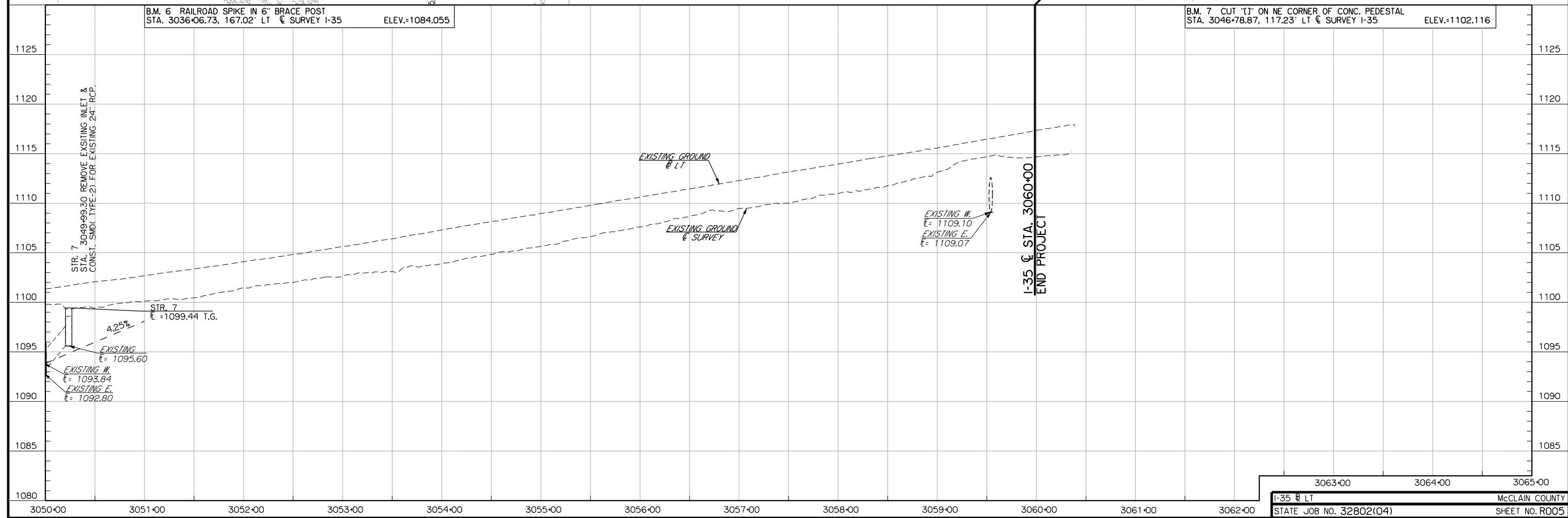

SECTION 2
T-6-N, R-2-W

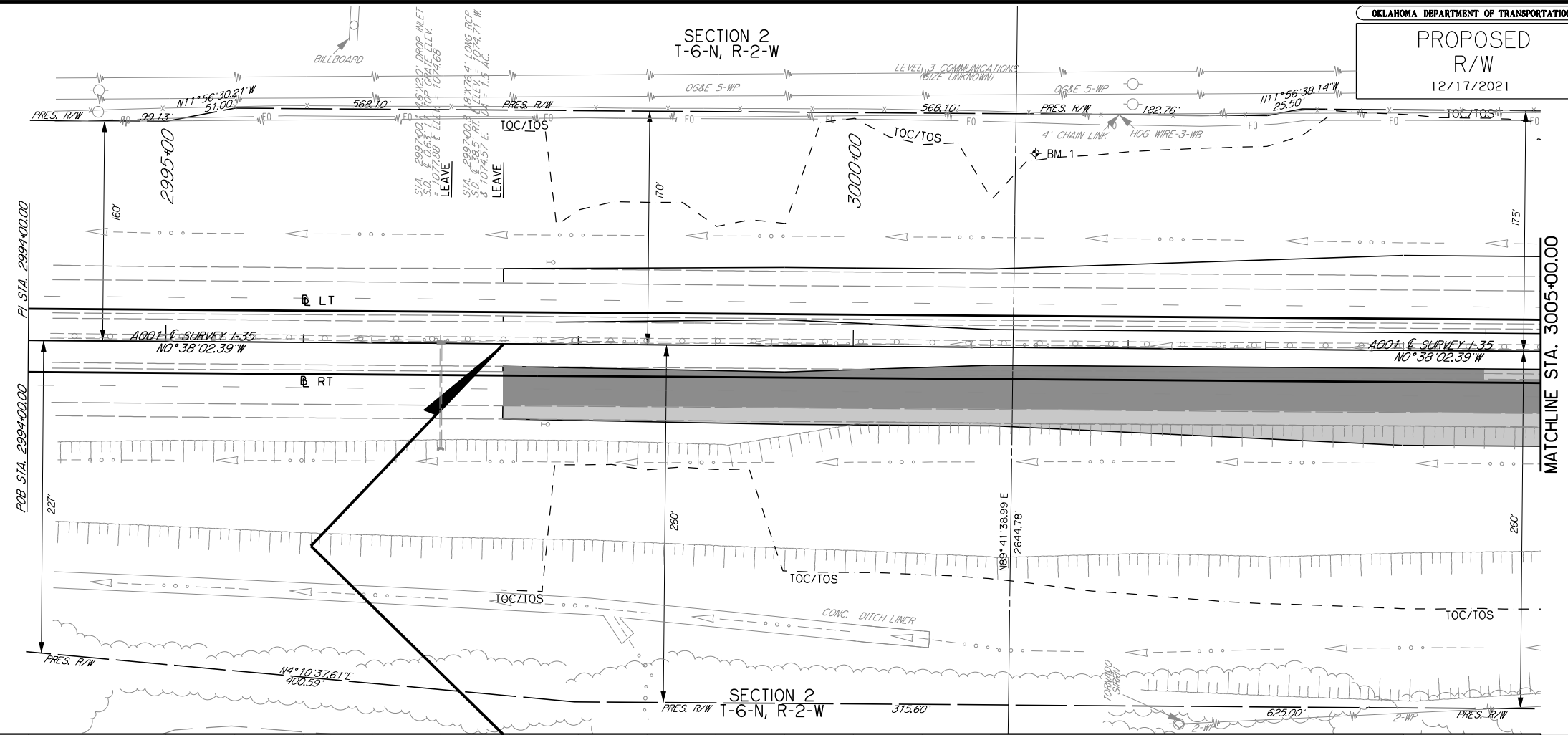

- KEY**
- FULL DEPTH
 - MILL & OVERLAY

SCALE:
 1" = 50' HOR
 1" = 5' VER

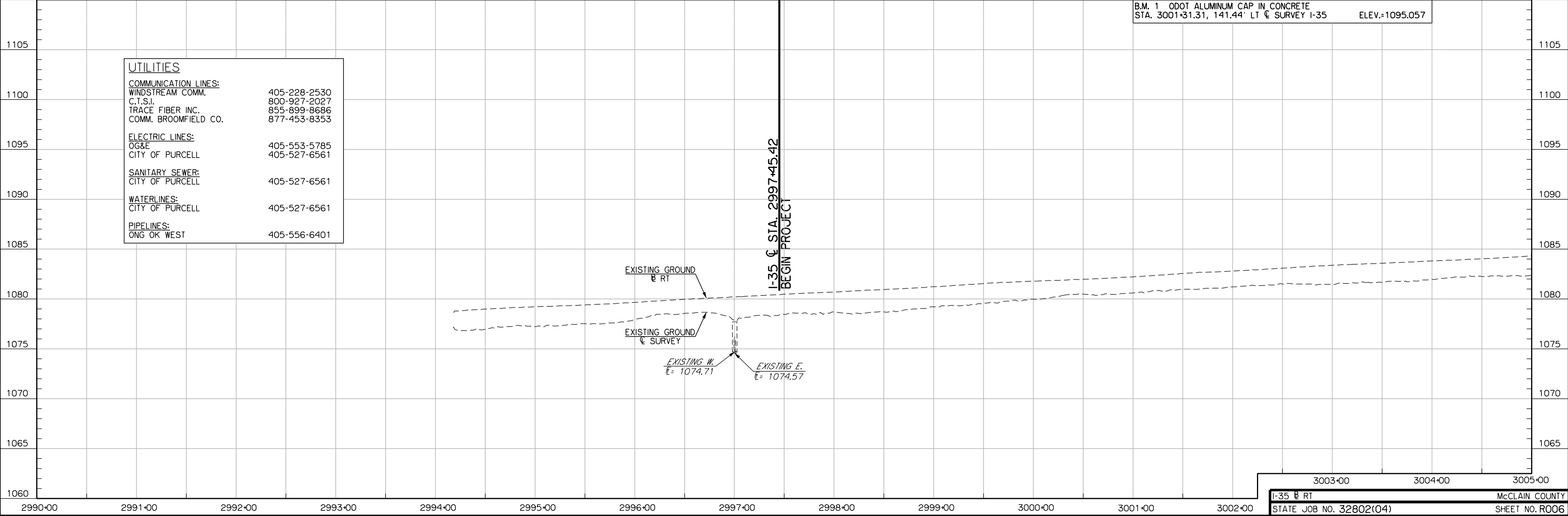

UTILITIES	
COMMUNICATION LINES:	
WINDSTREAM COMM.	405-228-2530
C.T.S.I.	800-927-2027
TRACE FIBER INC.	855-899-8686
COMM. BROOMFIELD CO.	877-453-8353
ELECTRIC LINES:	
OG&E	405-553-5785
CITY OF PURCELL	405-527-6561
SANITARY SEWER:	
CITY OF PURCELL	405-527-6561
WATERLINES:	
CITY OF PURCELL	405-527-6561
PIPELINES:	
ONG OK WEST	405-556-6401

B.M. 1 ODOT ALUMINUM CAP IN CONCRETE
 STA. 3001+31.31, 141.44' LT CL SURVEY I-35 ELEV.=1095.057

SECTION 2
T-6-N, R-2-W

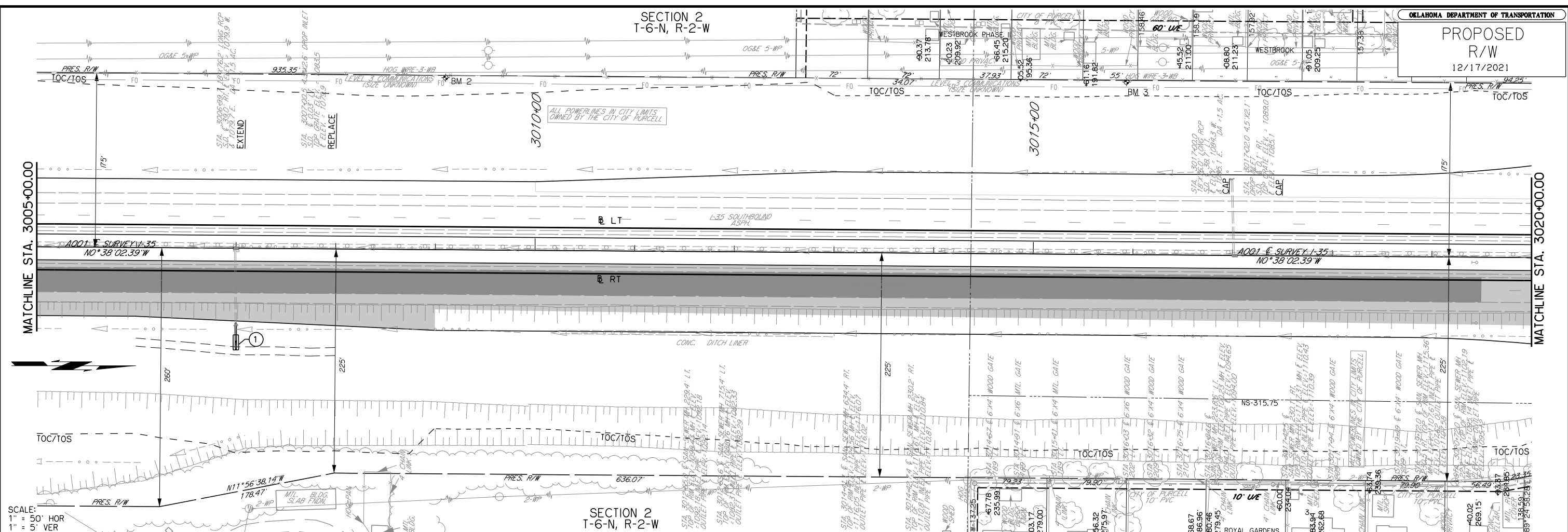

SCALE:
 1" = 50' HOR
 1" = 5' VER

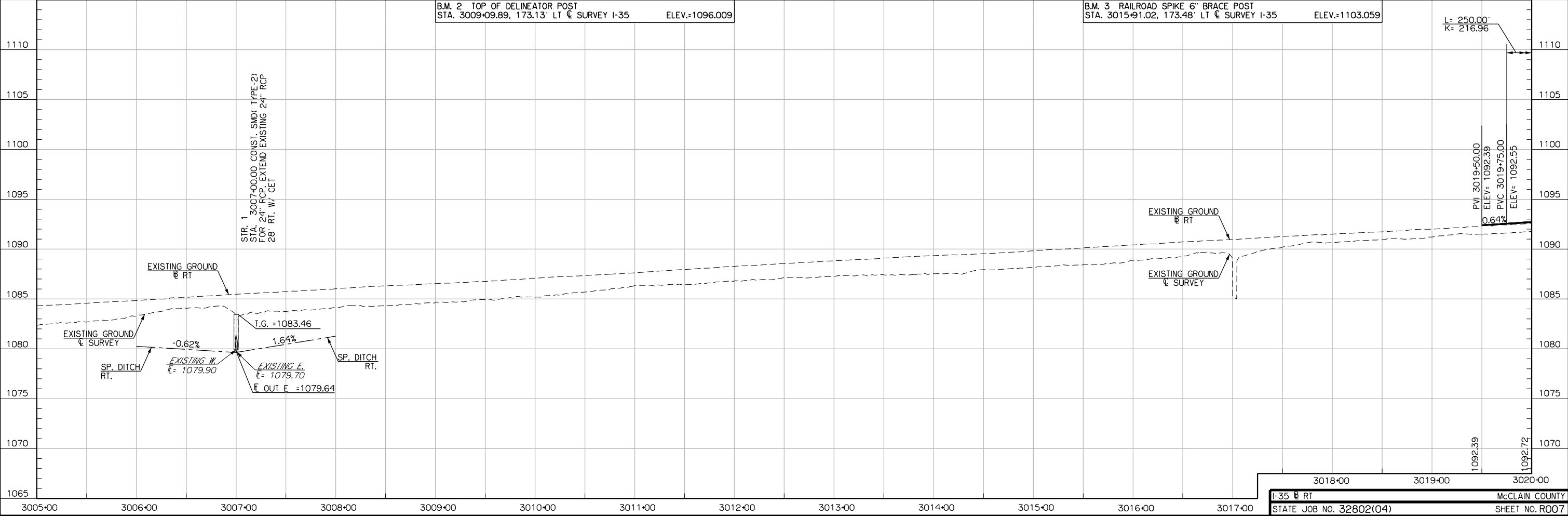

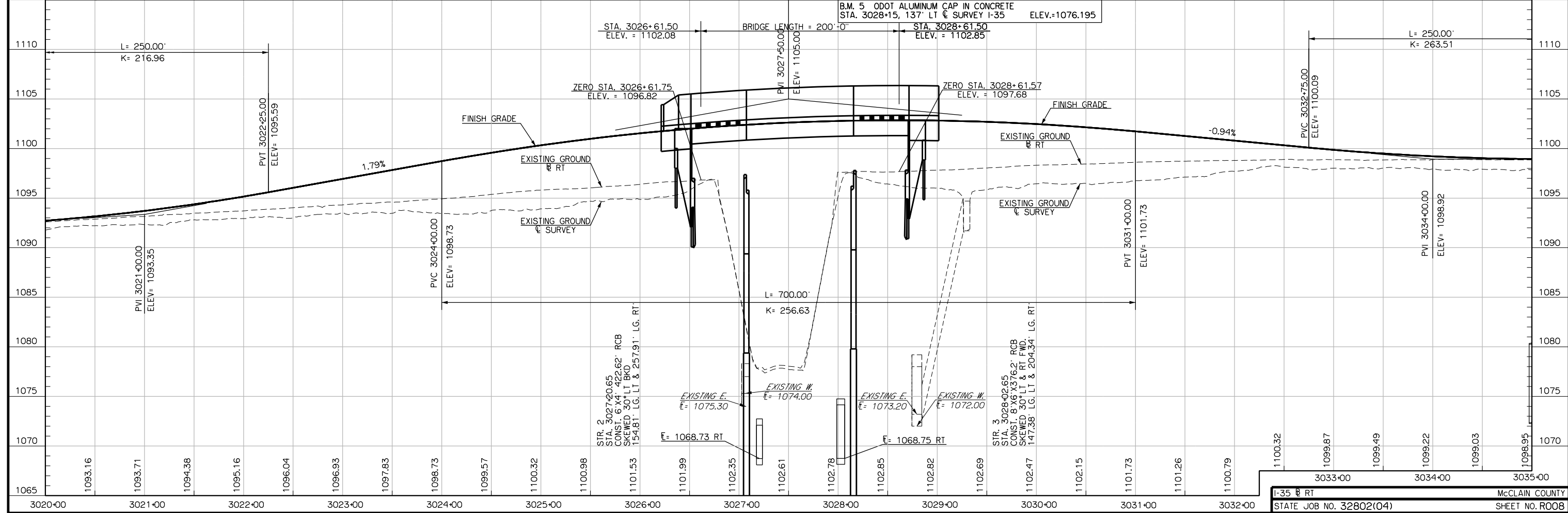
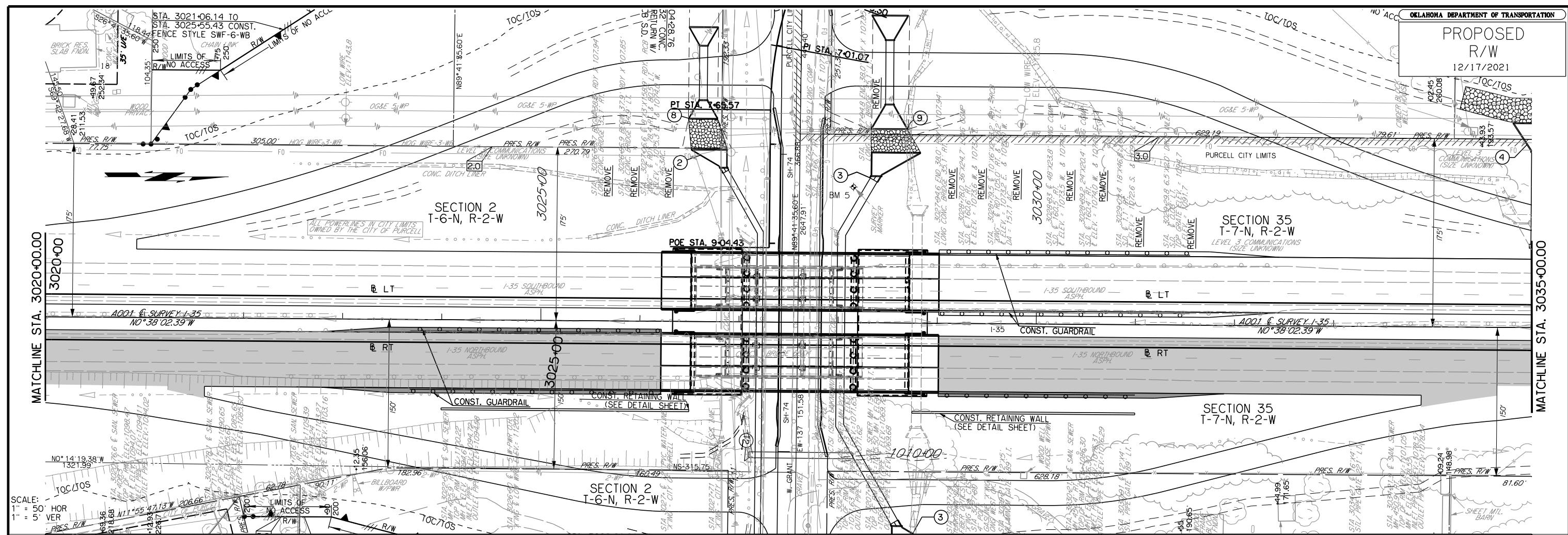

SECTION 35
T-7-N, R-2-W

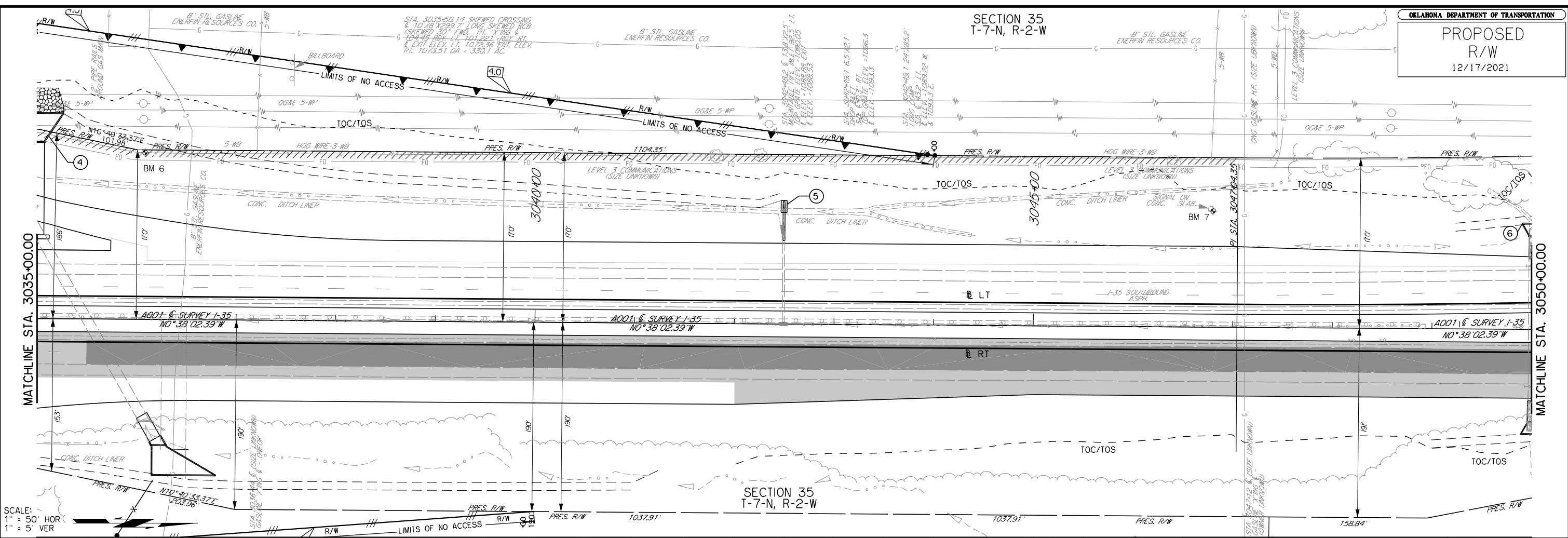

SCALE:
1" = 50' HOR
1" = 5' VER

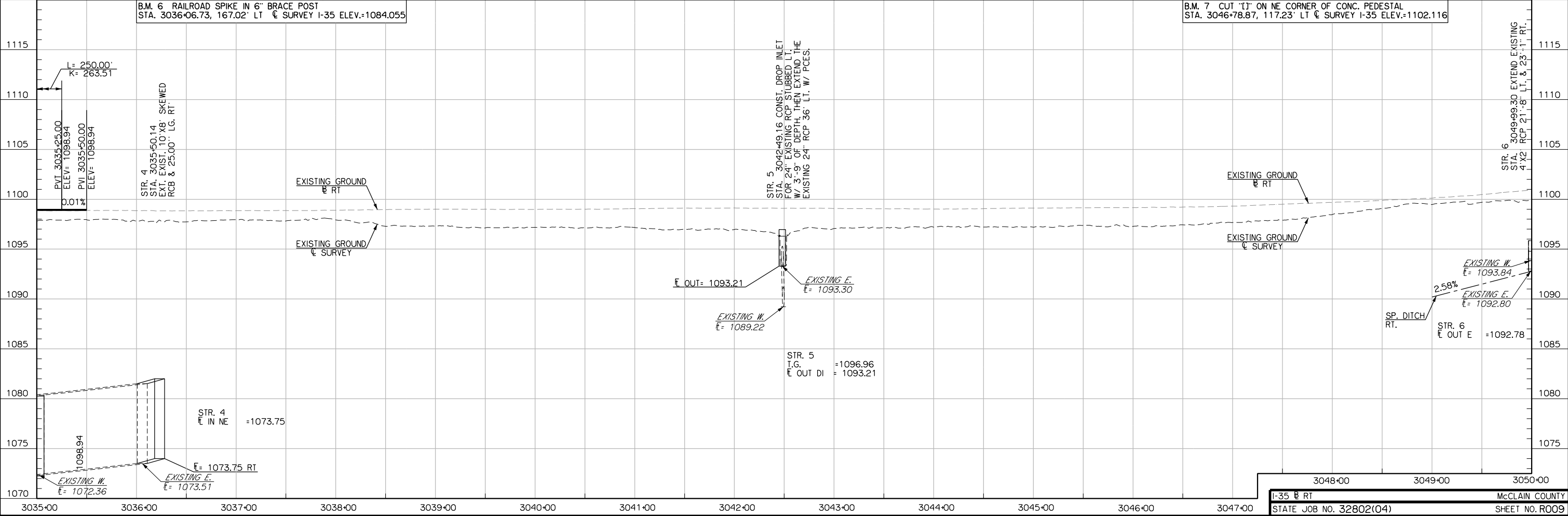

SECTION 35
T-7-N, R-2-W

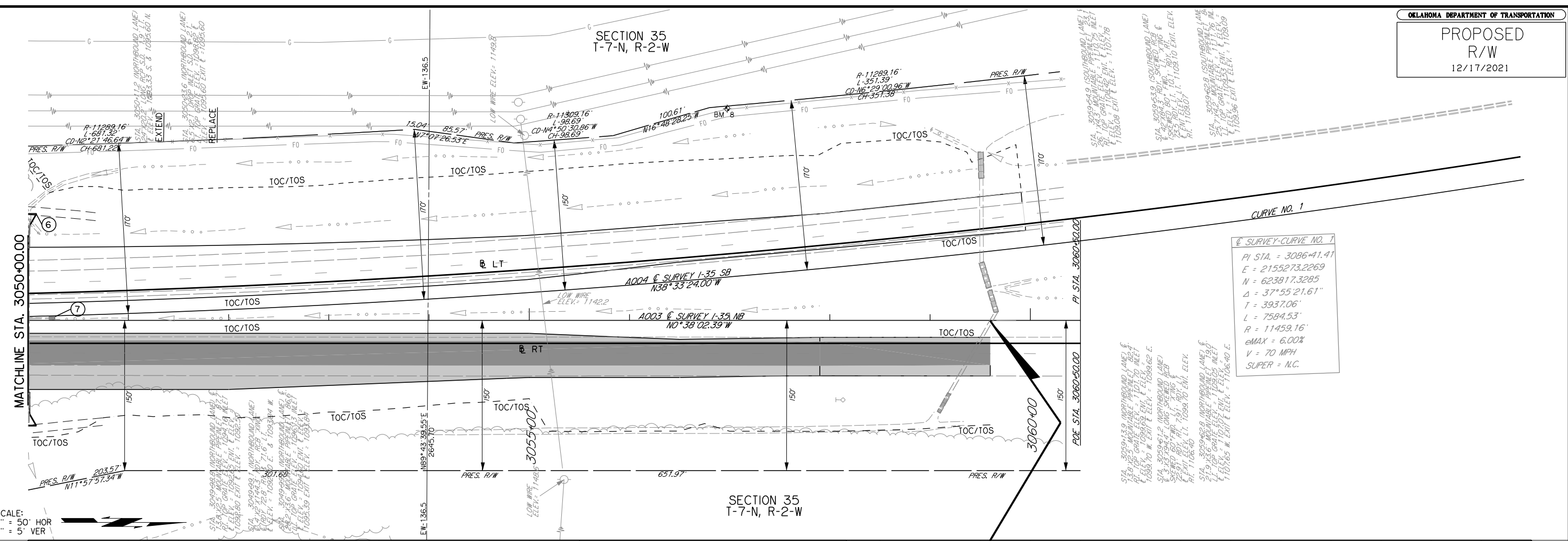

☉ SURVEY-CURVE NO. 1
 PI STA. = 3086+41.41
 E = 2155273.2269
 N = 623817.3285
 Δ = 37°55'21.61"
 T = 3937.06'
 L = 7584.53'
 R = 11459.16'
 eMAX = 6.00%
 V = 70 MPH
 SUPER = N.C.

STA. 3059+54.9 (SCULPTURE LANE) & P18 105.5' MOUNTAINABLE PILE INLET 25.1' ELEV. = 1098.62 E. ELEV. = 1098.62 E. ELEV. = 1098.62 E. ELEV. = 1098.62 E.
 STA. 3059+54.9 (SCULPTURE LANE) & P18 105.5' MOUNTAINABLE PILE INLET 25.1' ELEV. = 1098.62 E. ELEV. = 1098.62 E. ELEV. = 1098.62 E. ELEV. = 1098.62 E.
 STA. 3059+54.9 (SCULPTURE LANE) & P18 105.5' MOUNTAINABLE PILE INLET 25.1' ELEV. = 1098.62 E. ELEV. = 1098.62 E. ELEV. = 1098.62 E. ELEV. = 1098.62 E.

SCALE:
 1" = 50' HOR
 1" = 5' VER

B.M. 8 RAILROAD SPIKE IN 6" BRACE POST NO SURVEY GIVEN OUTSIDE SURVEY LIMITS ☉ SURVEY I-35 SB ELEV.=1117.53

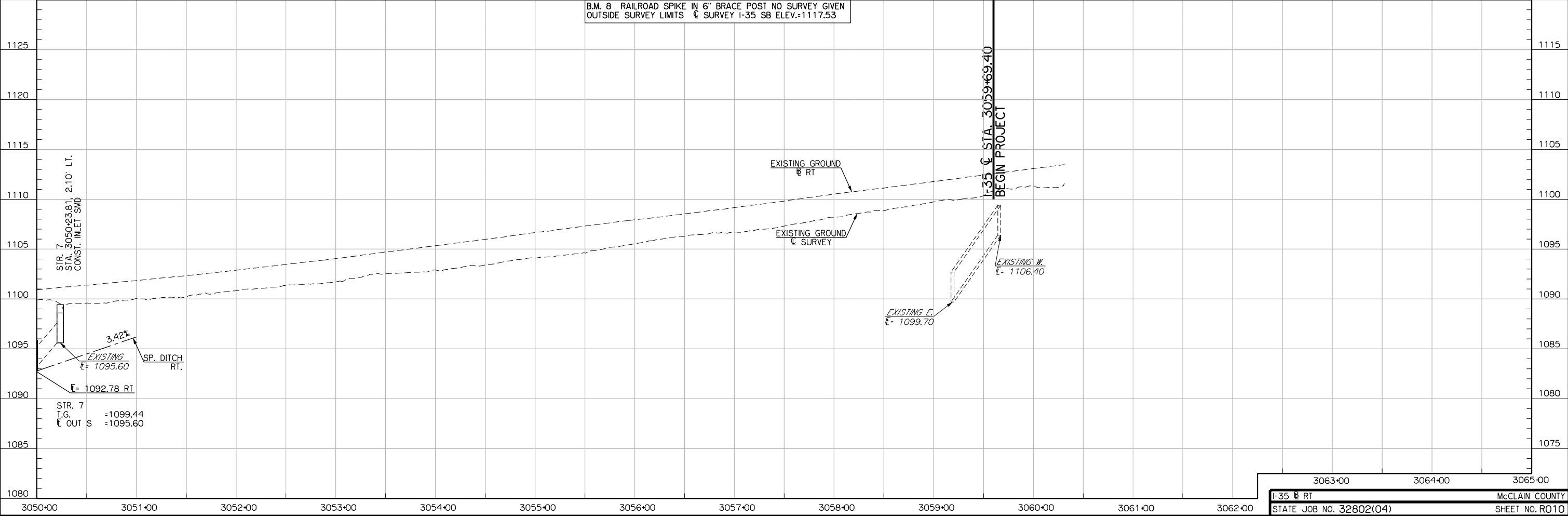

SECTION 2
T-6-N, R-2-W

KEY

- FULL DEPTH
- MILL & OVERLAY

ALL POWERLINES IN CITY LIMITS OWNED BY THE CITY OF PURCELL

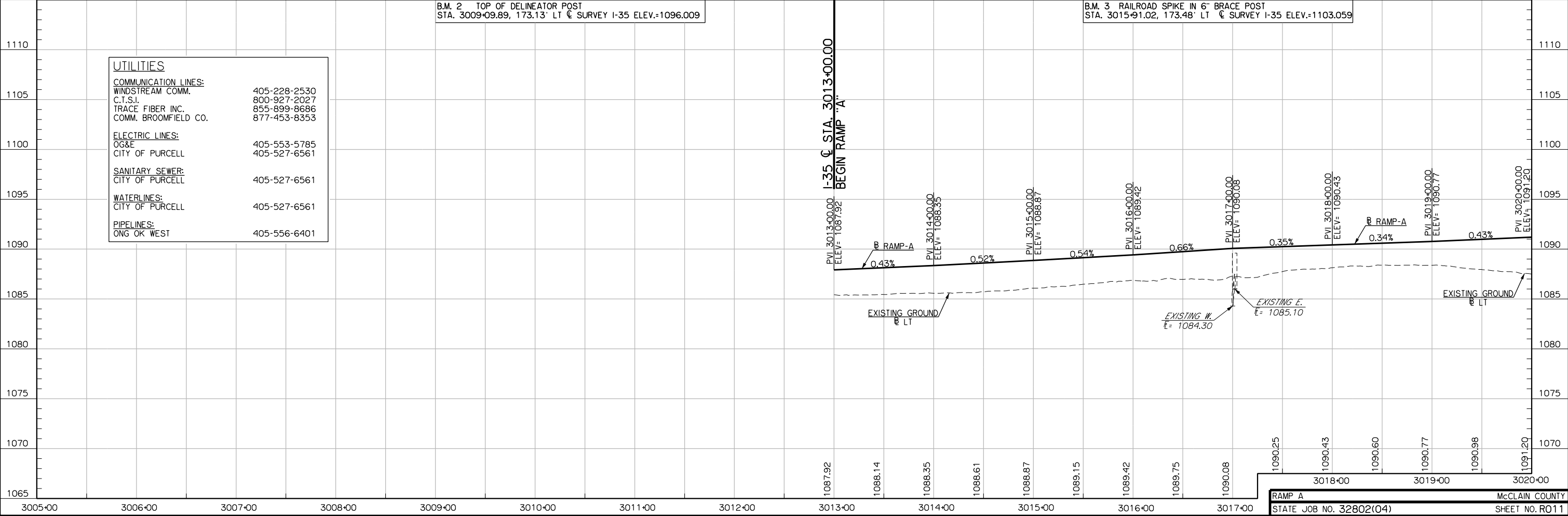
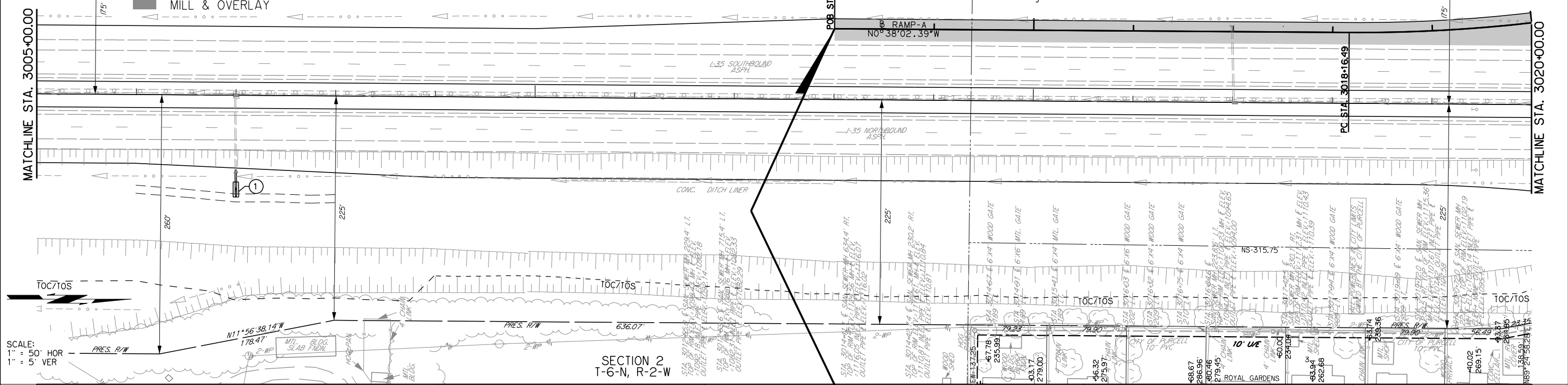

UTILITIES

COMMUNICATION LINES:	
WINDSTREAM COMM.	405-228-2530
C.T.S.I.	800-927-2027
TRACE FIBER INC.	855-899-8686
COMM. BROOMFIELD CO.	877-453-8353
ELECTRIC LINES:	
OG&E	405-553-5785
CITY OF PURCELL	405-527-6561
SANITARY SEWER:	
CITY OF PURCELL	405-527-6561
WATERLINES:	
CITY OF PURCELL	405-527-6561
PIPELINES:	
ONG OK WEST	405-556-6401

B.M. 2 TOP OF DELINEATOR POST
STA. 3009+09.89, 173.13' LT \angle SURVEY I-35 ELEV.=1096.009

B.M. 3 RAILROAD SPIKE IN 6" BRACE POST
STA. 3015+91.02, 173.48' LT \angle SURVEY I-35 ELEV.=1103.059

I-35 \angle STA. 3013+00.00
BEGIN RAMP "A"

RAMP A CURVE-1	RAMP A CURVE-2
PI STA.: 3021+59.18	PI STA. = 3025+98.80
E = 2155415.9491	E = 2155084.6151
N = 617336.2783	N = 617743.7759
Δ = 14° 39' 18.85"	Δ = 21° 41' 53.82"
T = 194.18'	T = 55.96'
L = 386.23'	L = 110.58'
R = 1510.00'	R = 292.00'
eMAX = 6.00%	eMAX = 6.00%
V = 50 MPH	V = 25 MPH
SUPER = 5.00%	SUPER = 5.00%

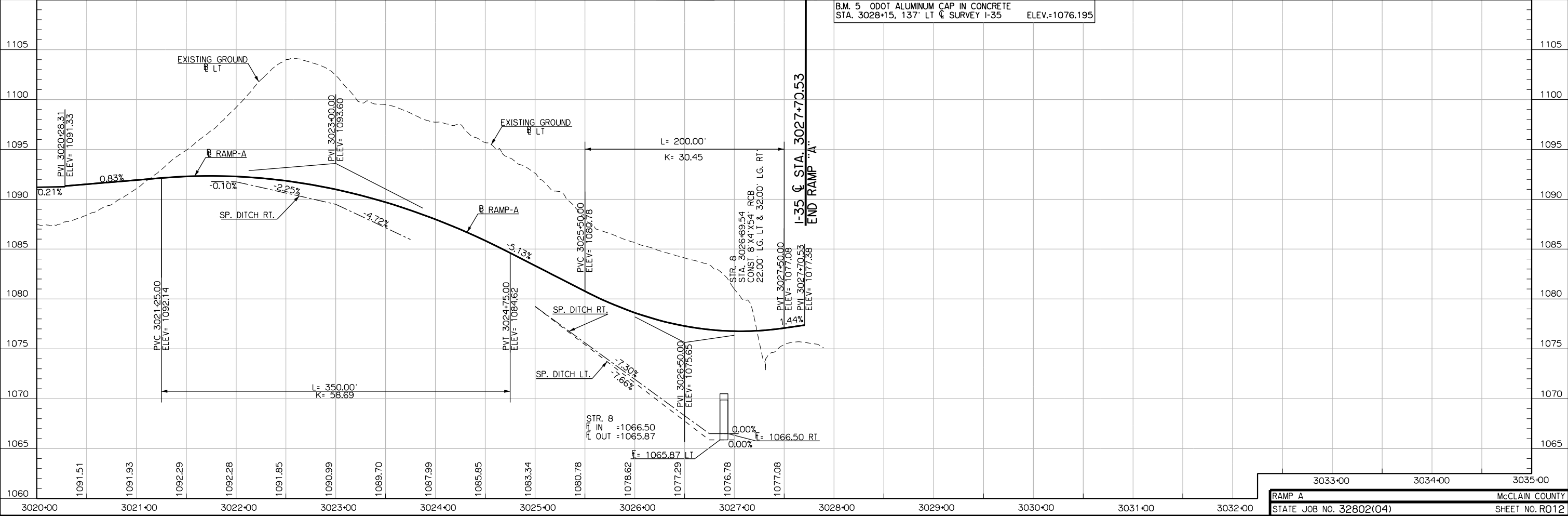
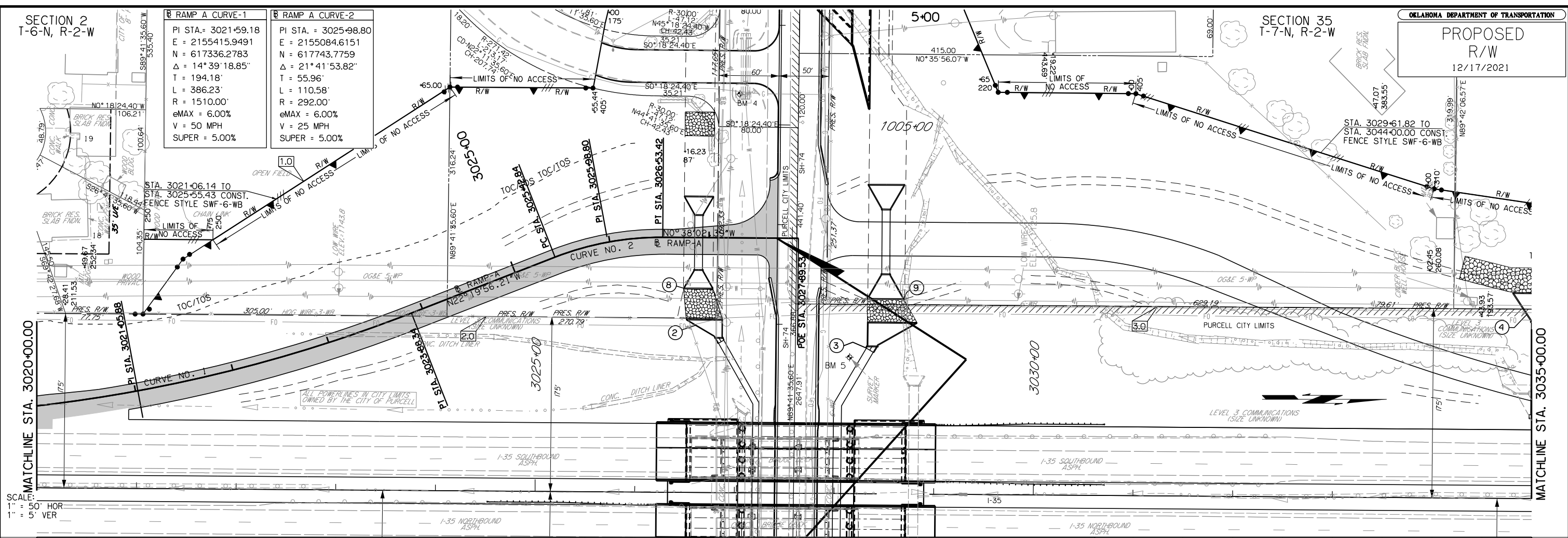

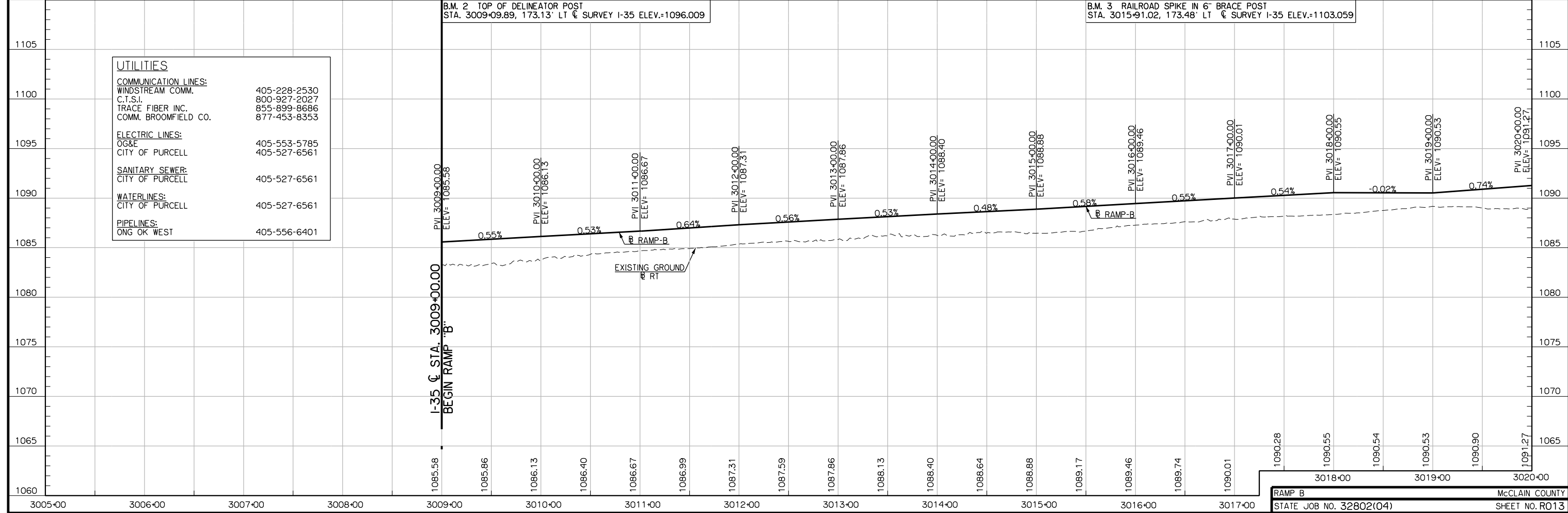
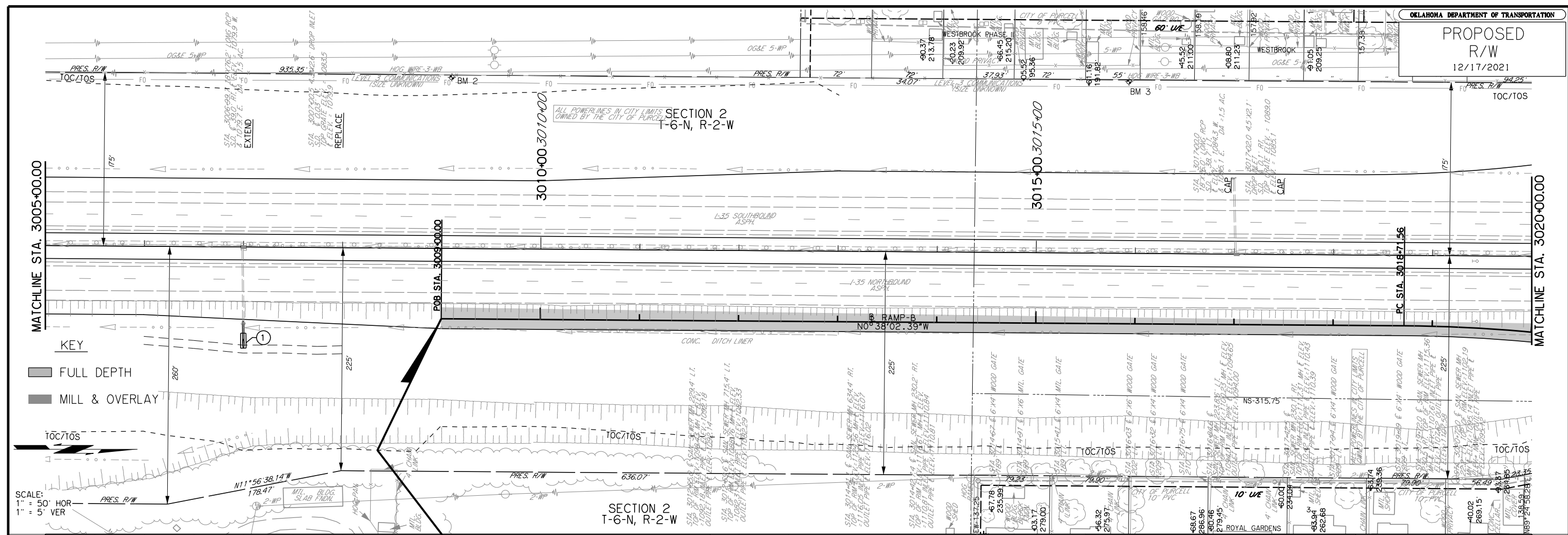

UTILITIES

COMMUNICATION LINES:	
WINDSTREAM COMM.	405-228-2530
C.T.S.I.	800-927-2027
TRACE FIBER INC.	855-899-8686
COMM. BROOMFIELD CO.	877-453-8353
ELECTRIC LINES:	
OG&E	405-553-5785
CITY OF PURCELL	405-527-6561
SANITARY SEWER:	
CITY OF PURCELL	405-527-6561
WATERLINES:	
CITY OF PURCELL	405-527-6561
PIPELINES:	
ONG OK WEST	405-556-6401

SECTION 2
T-6-N, R-2-W

RAMP B CURVE-1
 PI STA. = 3021+05.88
 E = 2155274.5476
 N = 617281.4150
 $\Delta = 21^\circ 41' 53.82''$
 T = 289.39'
 L = 571.85'
 R = 1510.00'
 eMAX = 6.00%
 V = 50 MPH
 SUPER = 5.00%

RAMP B CURVE-2
 PI STA. = 3025+68.12
 E = 2155515.5423
 N = 617735.0947
 $\Delta = 14^\circ 39' 18.85''$
 T = 58.64'
 L = 116.64'
 R = 456.00'
 eMAX = 6.00%
 V = 30 MPH
 SUPER = 5.00%

SECTION 35
T-7-N, R-2-W

OKLAHOMA DEPARTMENT OF TRANSPORTATION
 PROPOSED
 R/W
 12/17/2021

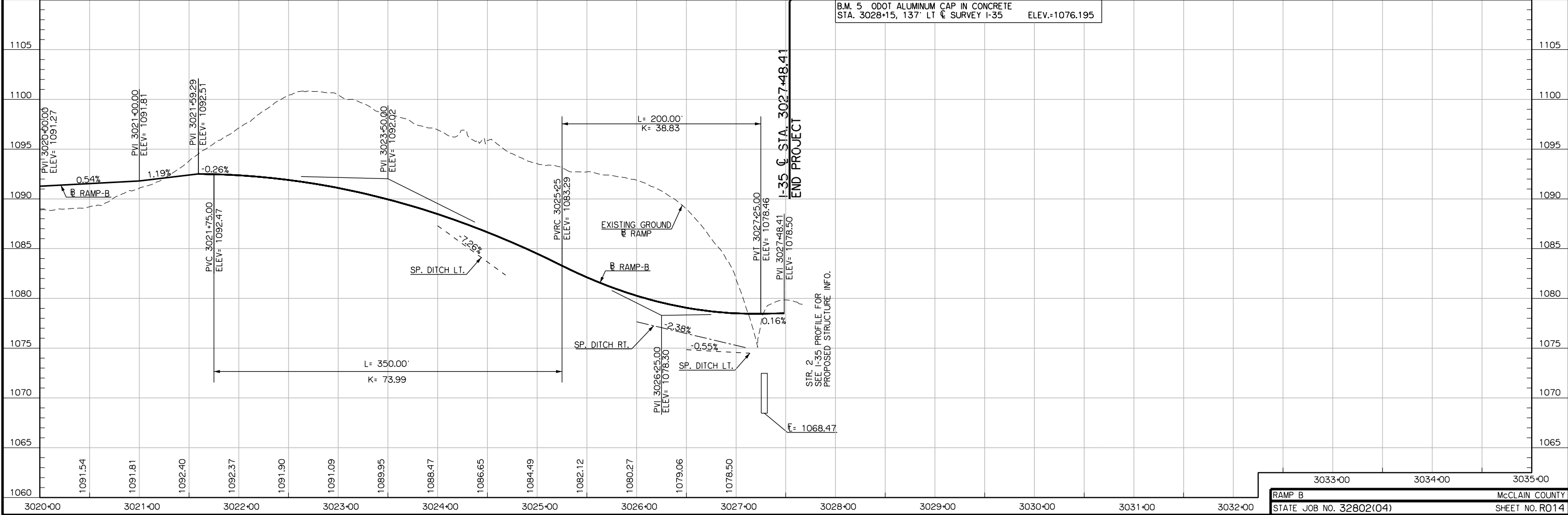
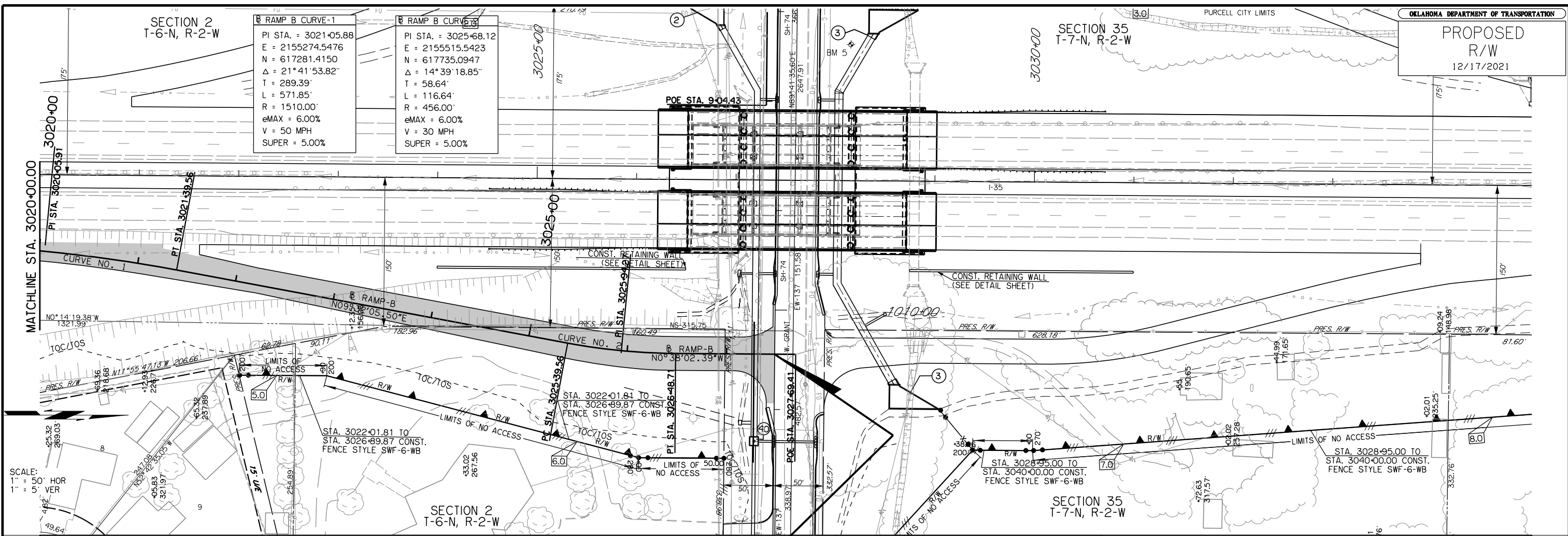

KEY
 [Grey Box] FULL DEPTH
 [Black Box] MILL & OVERLAY

STA. 3035+00.14 SKEWED CROSSING
 STA. 10129+12.59 7' LOW SKEWED BCP
 (SKEWED 30° EWD, RL, XING &
 104.45' RDY, LT, 101.221' RDY, RT,
 4' EXIT ELEV, LT, 102.36' EXIT ELEV,
 RT, 107.331' DA = 330.1' AC.

RAMP C CURVE-1
 PI STA. = 3030+73.58
 E = 2155078.7598
 N = 618272.9115
 Δ = 20°49'56.06"
 T = 83.82'
 L = 165.80'
 R = 456.00'
 eMAX = 6.00%
 V = 30 MPH
 SUPER = 5.00%

RAMP C CURVE-2
 PI STA. = 3034+72.03
 E = 2155401.4462
 N = 618646.8903
 Δ = 14°39'18.85"
 T = 194.18'
 L = 386.23'
 R = 1510.00'
 eMAX = 6.00%
 V = 50 MPH
 SUPER = 5.00%

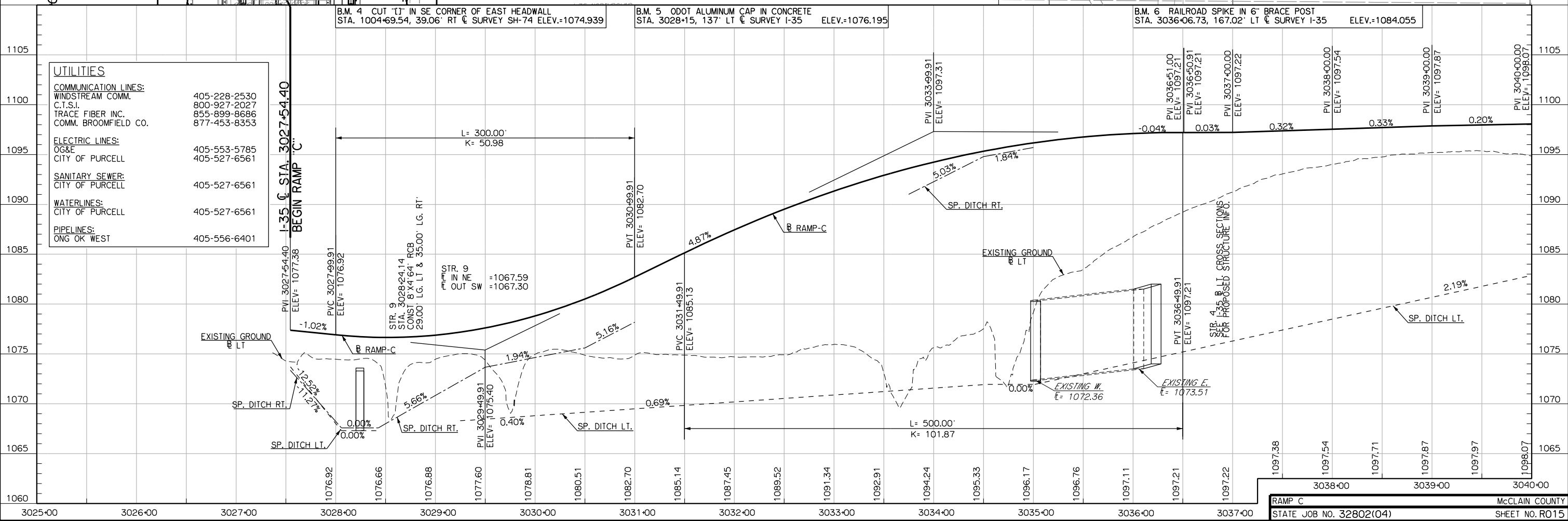
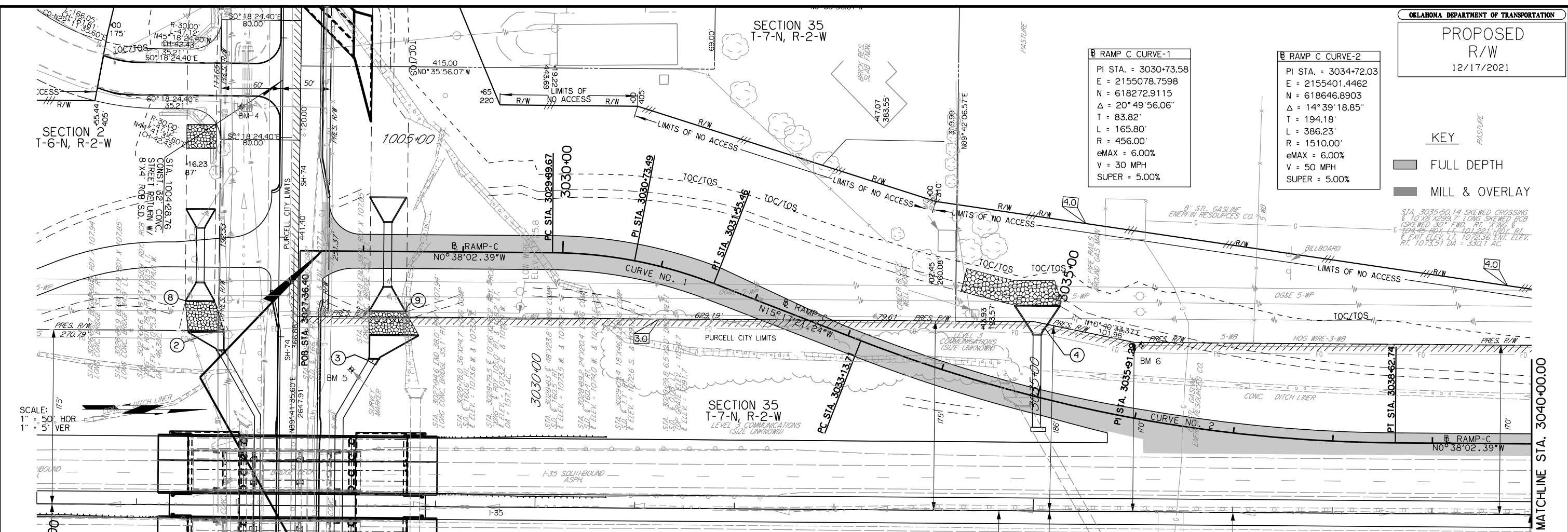

UTILITIES

COMMUNICATION LINES:
 WINDSTREAM COMM. 405-228-2530
 C.T.S.I. 800-927-2027
 TRACE FIBER INC. 855-899-8696
 COMM. BROOMFIELD CO. 877-453-8353

ELECTRIC LINES:
 OG&E 405-553-5785
 CITY OF PURCELL 405-527-6561

SANITARY SEWER:
 CITY OF PURCELL 405-527-6561

WATERLINES:
 CITY OF PURCELL 405-527-6561

PIPELINES:
 ONG OK WEST 405-556-6401

B.M. 4 CUT "I" IN SE CORNER OF EAST HEADWALL
 STA. 1004+69.54, 39.06' RT CL SURVEY SH-74 ELEV.=1074.939

B.M. 5 ODOT ALUMINUM CAP IN CONCRETE
 STA. 3028+15, 137' LT CL SURVEY I-35 ELEV.=1076.195

B.M. 6 RAILROAD SPIKE IN 6" BRACE POST
 STA. 3036+06.73, 167.02' LT CL SURVEY I-35 ELEV.=1084.055

SECTION 35
 T-7-N, R-2-W

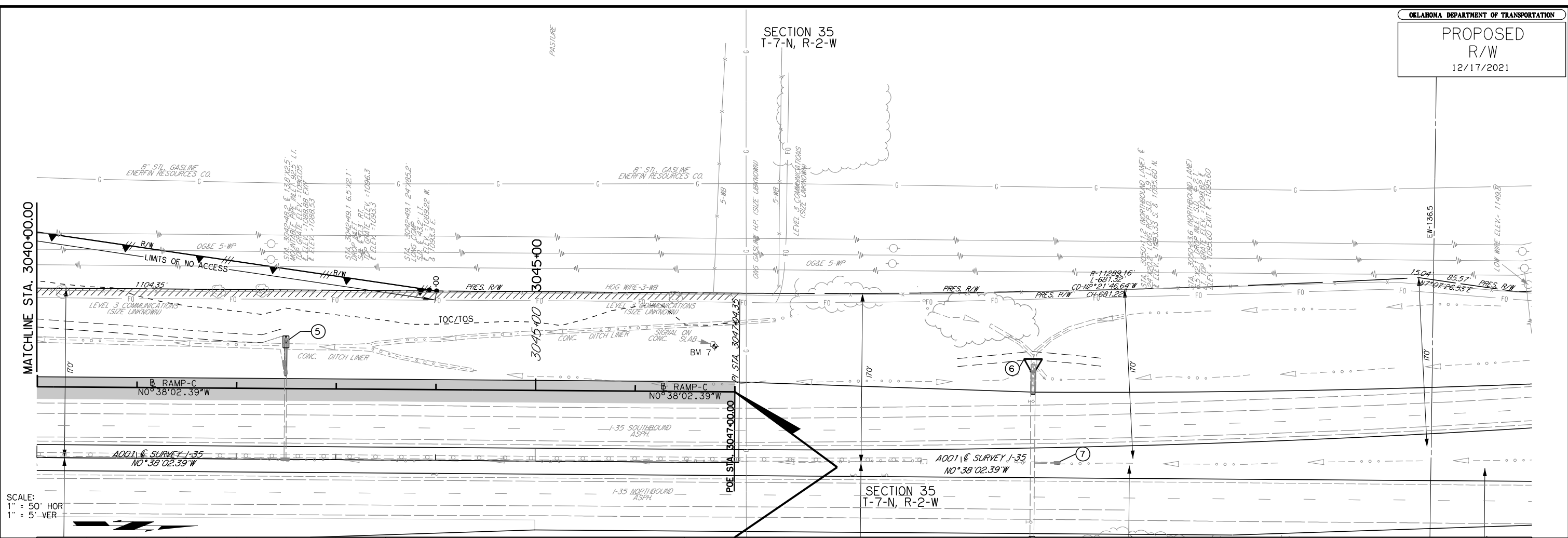

SCALE:
 1" = 50' HOR
 1" = 5' VER

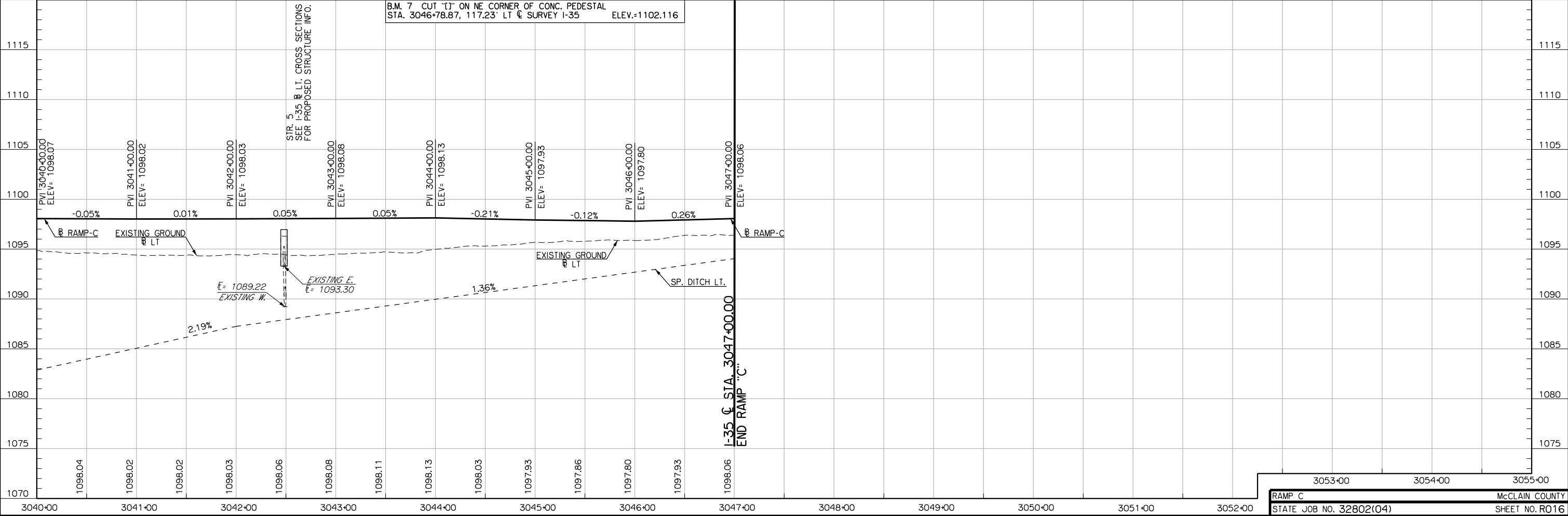

B.M. 7 CUT "C" ON NE CORNER OF CONC. PEDESTAL
 STA. 3046+78.87, 117.23' LT & SURVEY I-35 ELEV.=1102.116

STR. 5
 B LT. CROSS SECTIONS
 SEE I-35 FOR PROPOSED STRUCTURE INFO.

I-35 & STA. 3047+00.00
 END RAMP "C"

SECTION 35
 T-7-N, R-2-W

SECTION 2
 T-6-N, R-2-W

RAMP D CURVE-1	RAMP D CURVE-2
PI STA. = 3030+61.60	PI STA. = 3035+91.38
E = 2155509.8403	E = 2155258.1792
N = 618250.3754	N = 618760.6052
Δ = 14° 39' 18.85"	Δ = 20° 49' 56.06"
T = 58.64'	T = 277.58'
L = 116.64'	L = 549.02'
R = 456.00'	R = 1510.00'
eMAX = 6.00%	eMAX = 6.00%
V = 30 MPH	V = 50 MPH
SUPER = 5.00%	SUPER = 5.00%

MATCHLINE STA. 3025+00.00

MATCHLINE STA. 3040+00.00

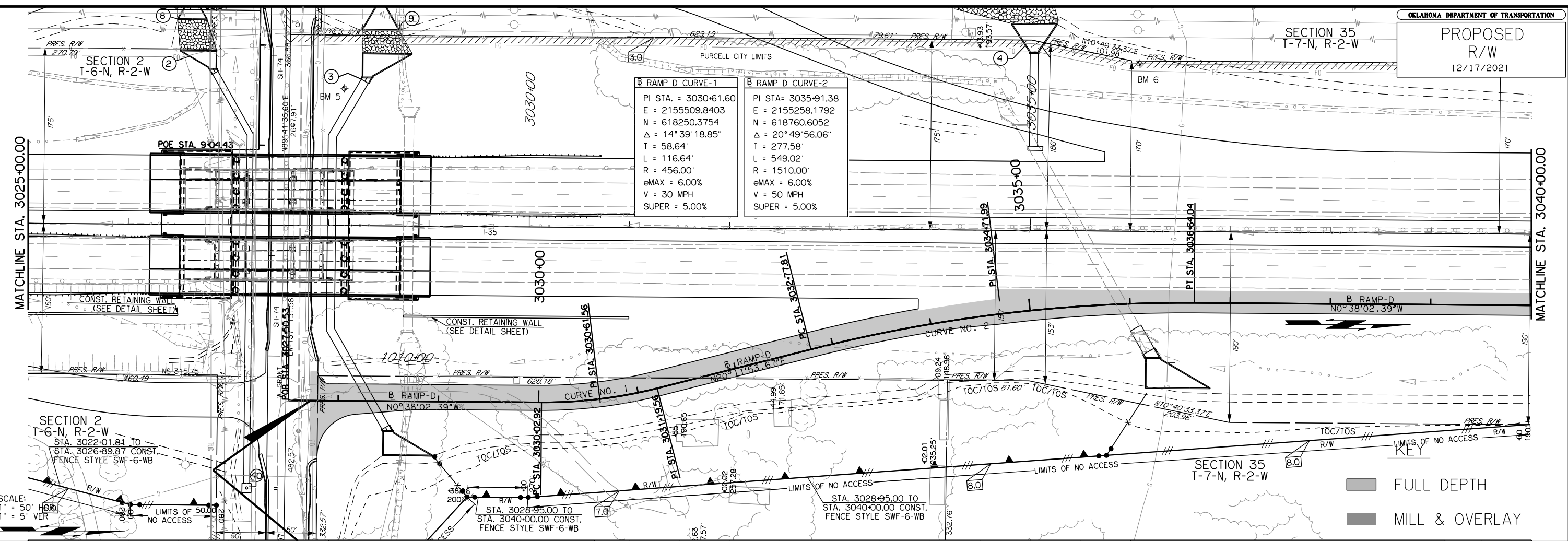

SCALE:
 1" = 50' HOR
 1" = 5' VER

KEY
 FULL DEPTH
 MILL & OVERLAY

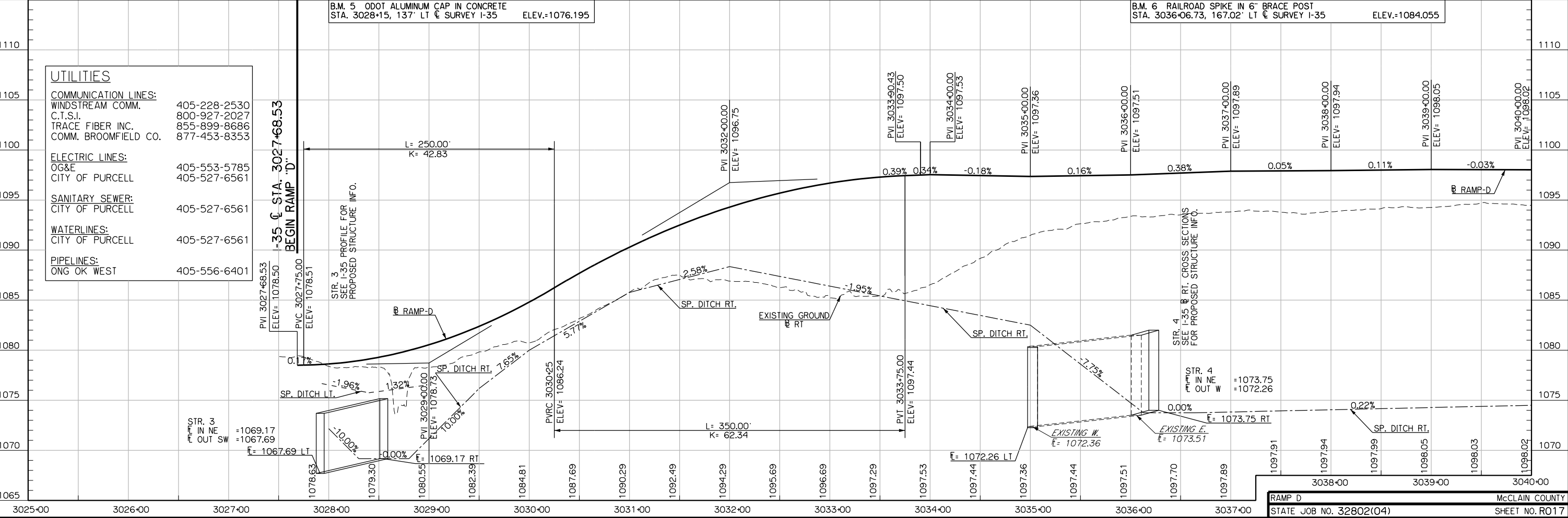

SECTION 35
 T-7-N, R-2-W

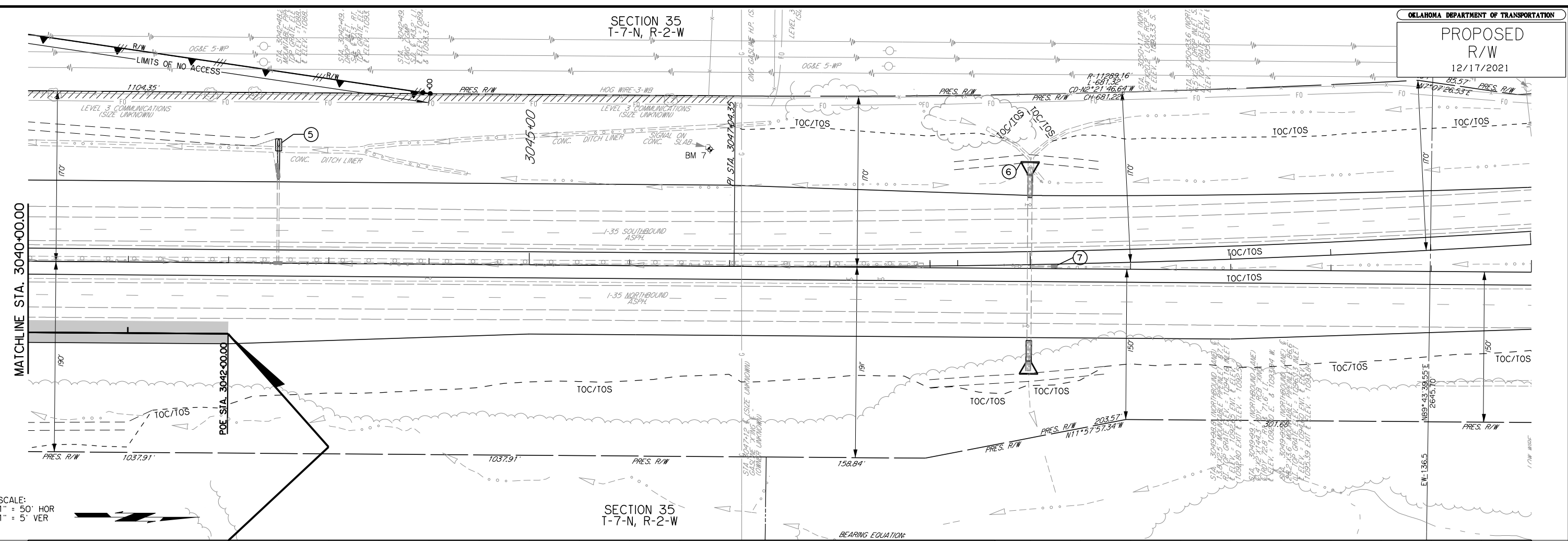

SCALE:
 1" = 50' HOR
 1" = 5' VER

SECTION 35
 T-7-N, R-2-W

BEARING EQUATION:
 B.M. 7 CUT 'I' ON NE CORNER OF CONC. PEDESTAL
 STA. 3046+78.87, 117.23' LT & SURVEY I-35 ELEV.=1102.116

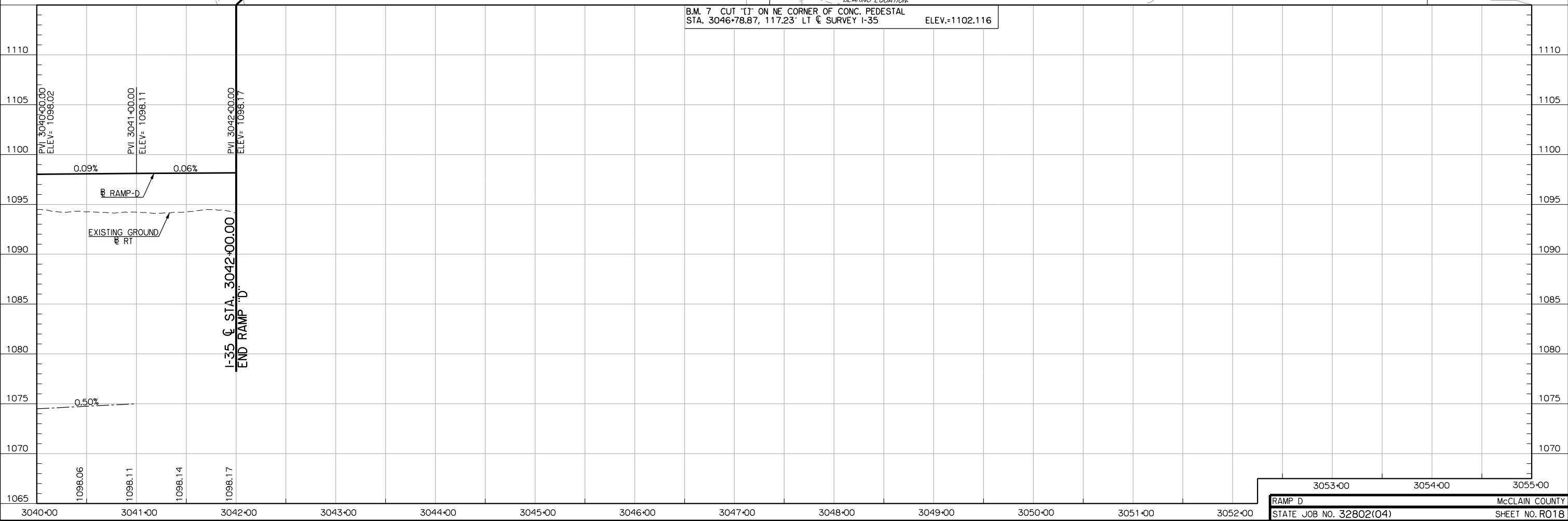

SURVEY CURVE NO. 1
 PI STA. = 978+18.94
 E = 2152859.9733
 N = 619245.7114
 Δ = 15°01'18.78"
 T = 251.44'
 L = 499.99'
 R = 1907.04'
 eMAX = 6.00%
 V = 50 MPH
 SUPER = 4.44%

SECTION 35
T-7-N, R-2-W

SECTION 35
T-7-N, R-2-W

SECTION 2
T-6-N, R-2-W

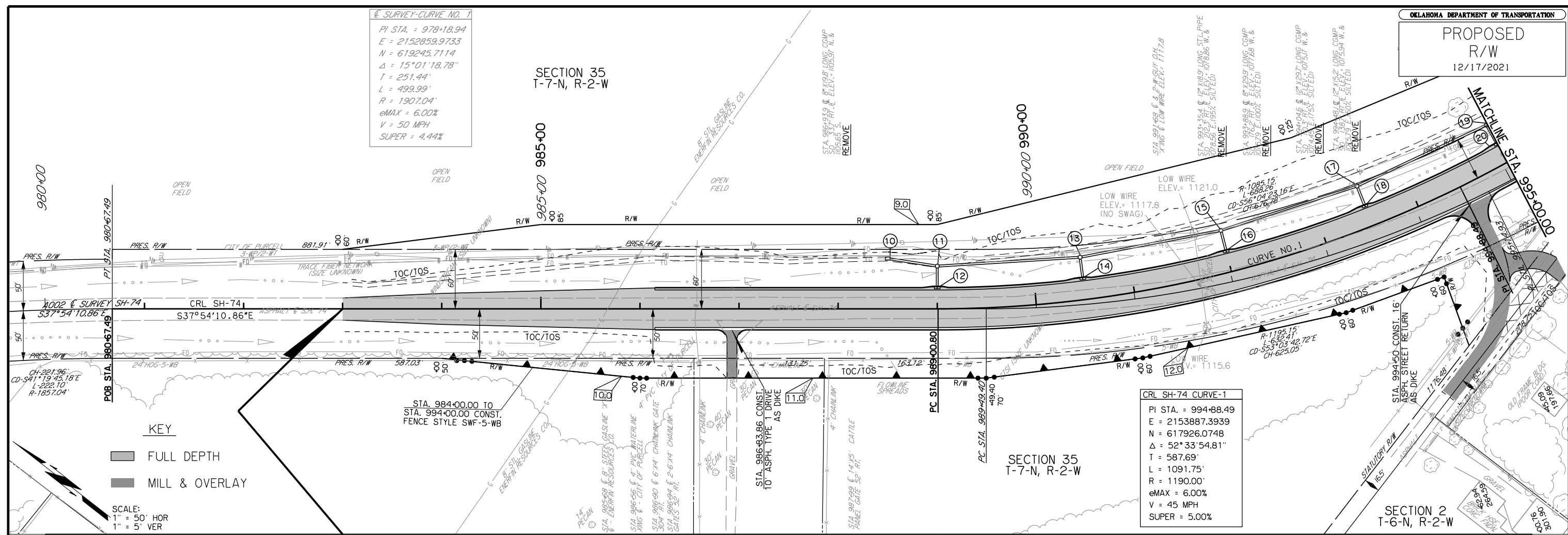

KEY
 [Symbol] FULL DEPTH
 [Symbol] MILL & OVERLAY

SCALE:
 1" = 50' HOR
 1" = 5' VER

CRL SH-74 CURVE-1
 PI STA. = 994+88.49
 E = 2153887.3939
 N = 617926.0748
 Δ = 52°33'54.81"
 T = 587.69'
 L = 1091.75'
 R = 1190.00'
 eMAX = 6.00%
 V = 45 MPH
 SUPER = 5.00%

UTILITIES

COMMUNICATION LINES:	
WINDSTREAM COMM. C.T.S.I.	405-228-2530
TRACE FIBER INC.	800-927-2027
COMM. BROOMFIELD CO.	855-899-8686
	877-453-8353
ELECTRIC LINES:	
OG&E	405-553-5785
CITY OF PURCELL	405-527-6561
SANITARY SEWER:	
CITY OF PURCELL	405-527-6561
WATERLINES:	
CITY OF PURCELL	405-527-6561
PIPELINES:	
ONG OK WEST	405-556-6401

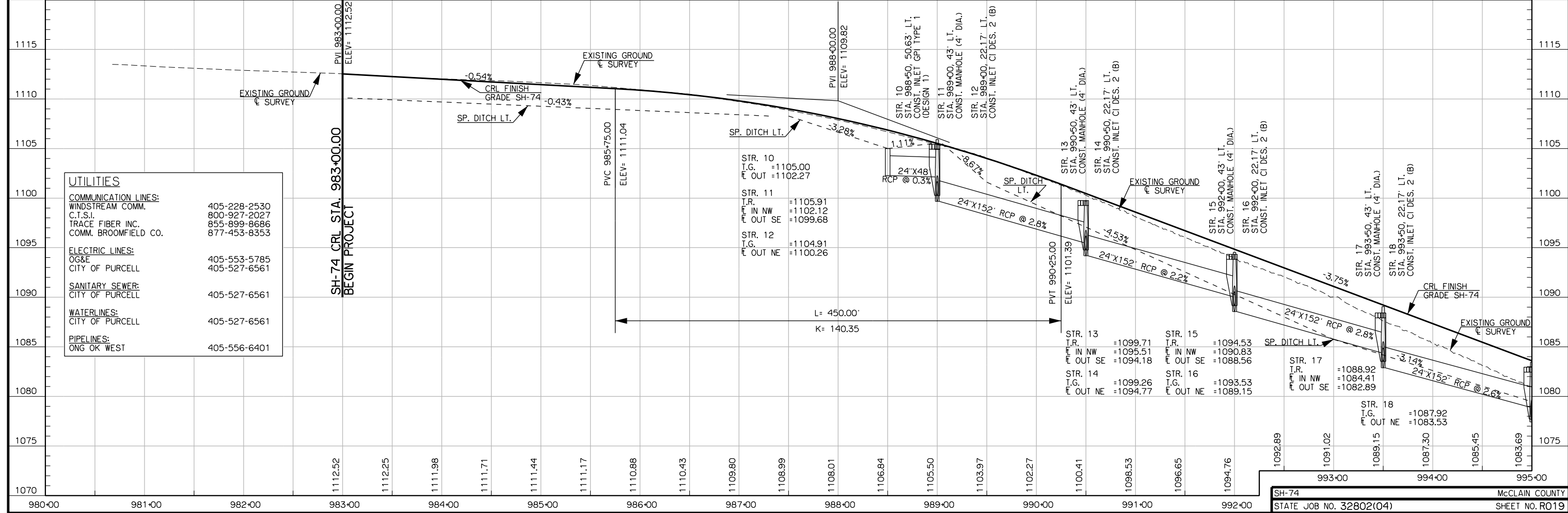

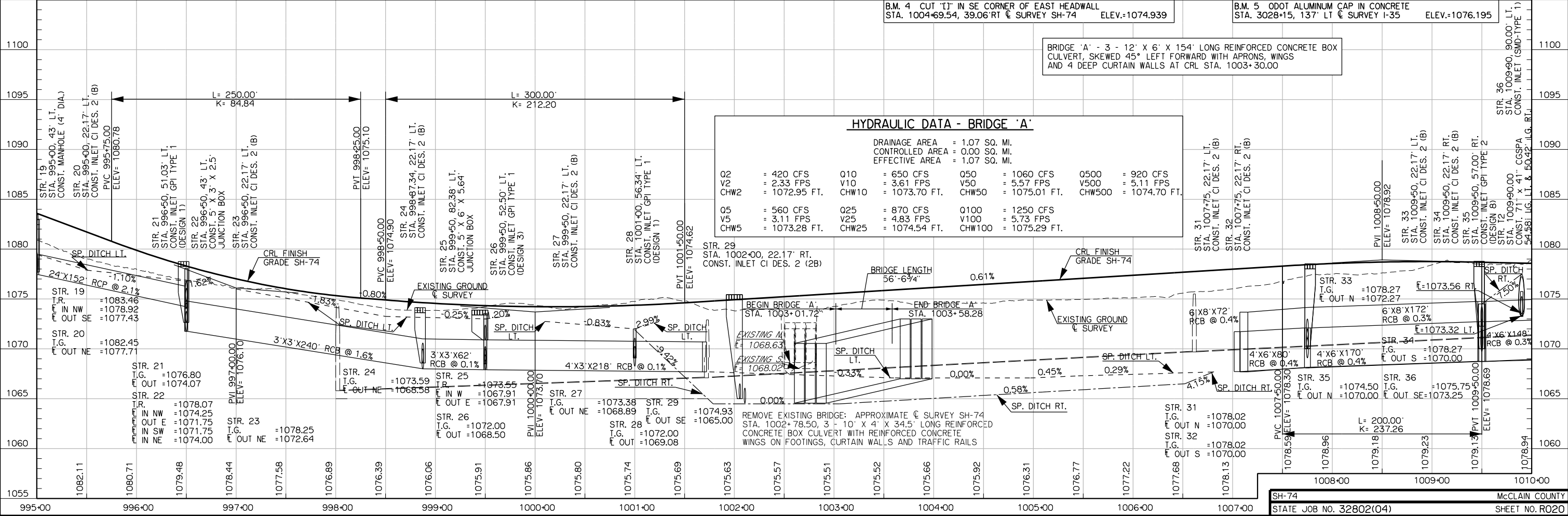
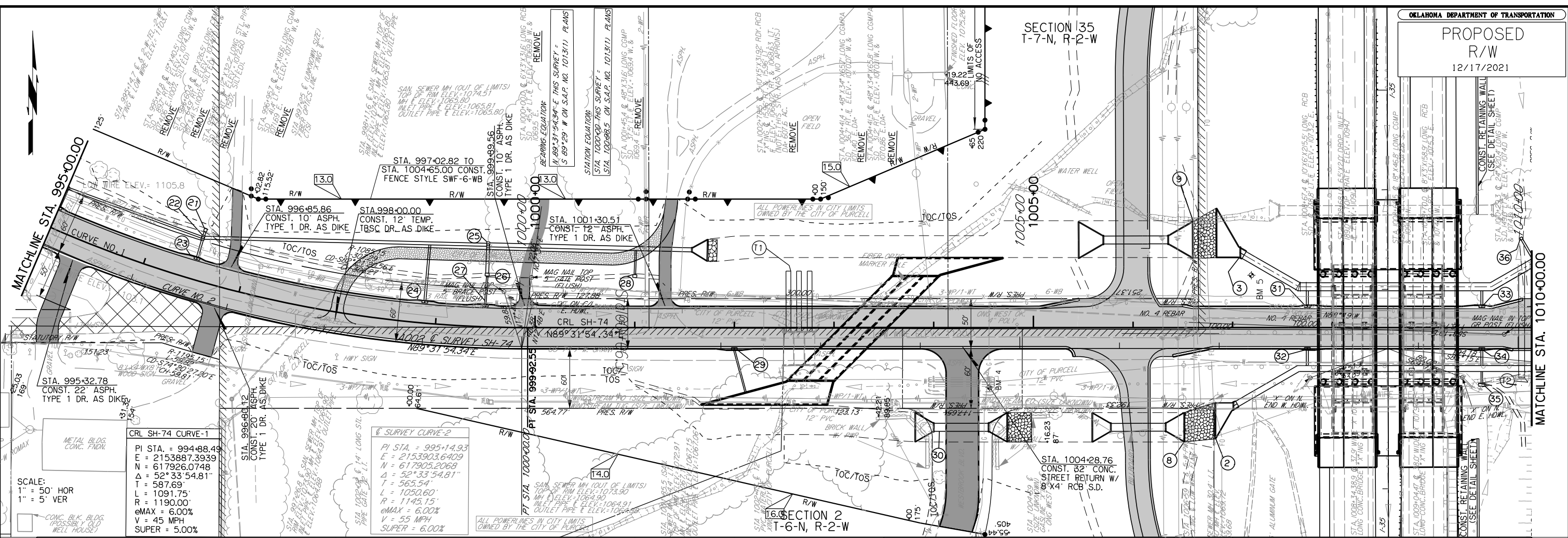

SH-74 CRL CURVE-2	SH-74 CRL CURVE-3
PI STA. = 1020+77.07 E = 2156559.5099 N = 6179947.9127 Δ = 3°15'43.73" T = 184.52 L = 368.94 R = 6480.00 eMAX = XX% V = 45 MPH SUPER = NC	PI STA. = 1024+46.01 E = 2156928.1110 N = 617929.9244 Δ = 3°15'43.73" T = 184.52 L = 368.94 R = 6480.00 eMAX = XX% V = 45 MPH SUPER = NC

SECTION 36 T-7-N, R-2-W

SECTION 1 T-6-N, R-2-W

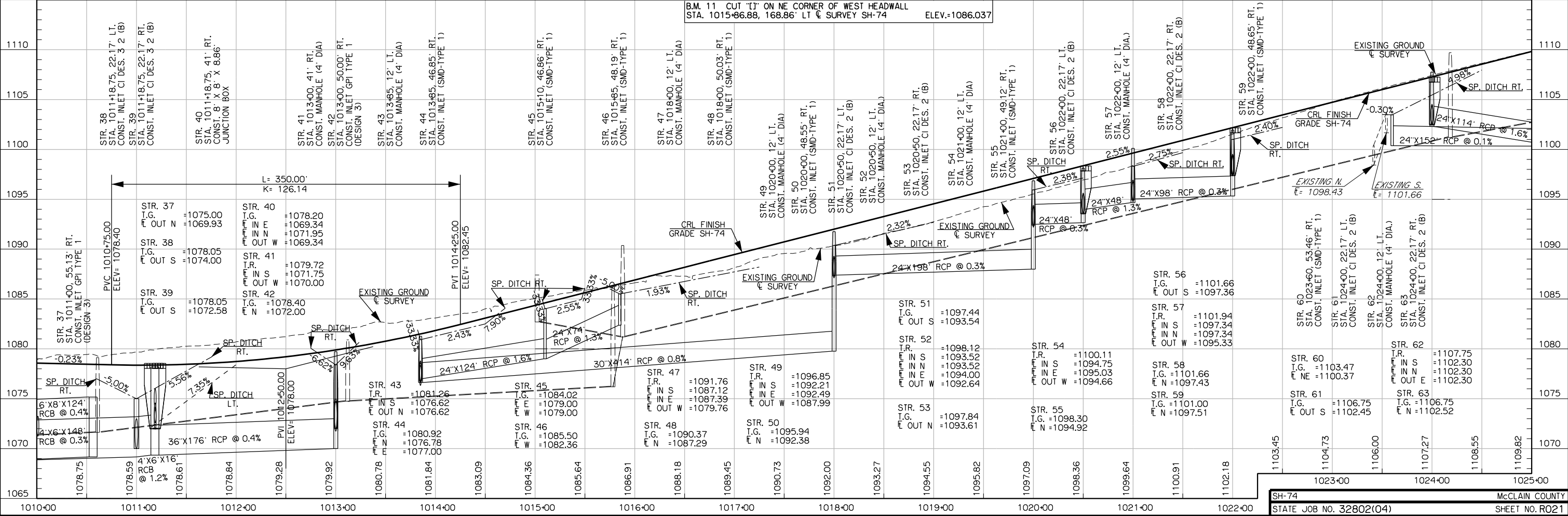
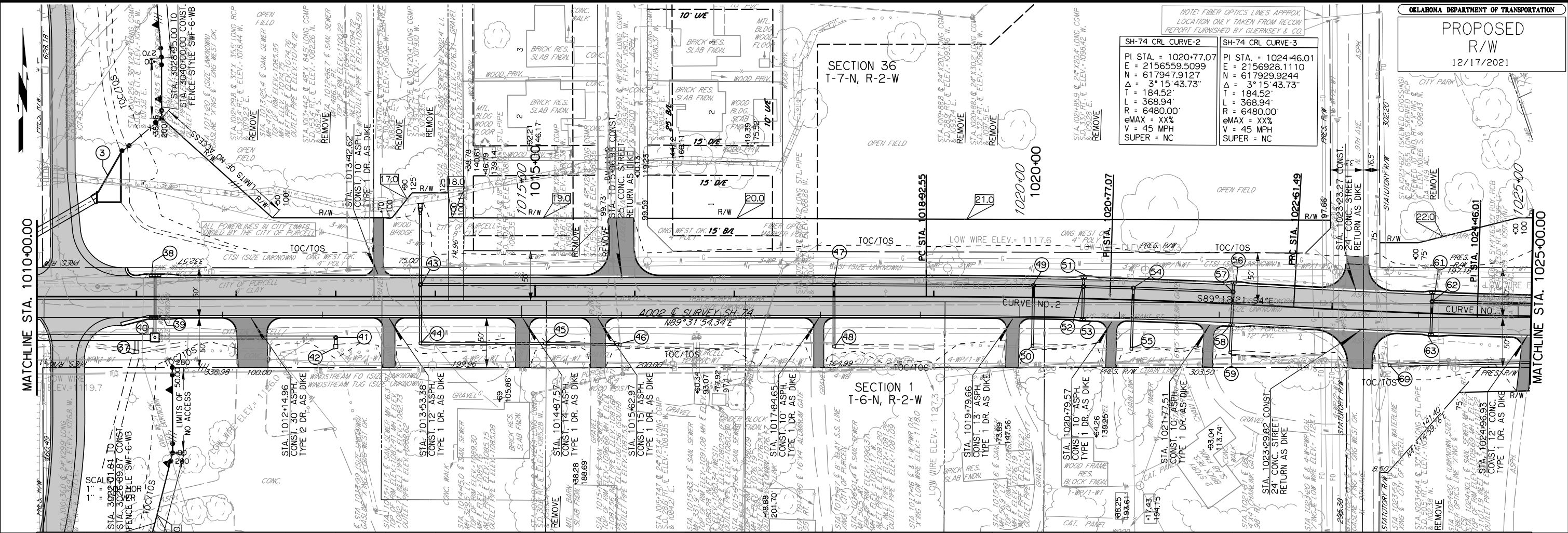

SECTION 36 T-7-N, R-2-W

BEARING EQUATION: N 89°31'54.34" E THIS SURVEY = S 89°29' W ON S.A.P. NO. 10131(1) PLANS = N 89°46'18.46" E ON S.W.O. 2036(3) SURVEY. STATION EQUATION: STA. 1038+11.94 THIS SURVEY = STA. 62+86.59 ON S.A.P. NO. 10131(1) PLANS = STA. 5+083.709 (METRIC) ON S.W.O. 2036(3) SURVEY.

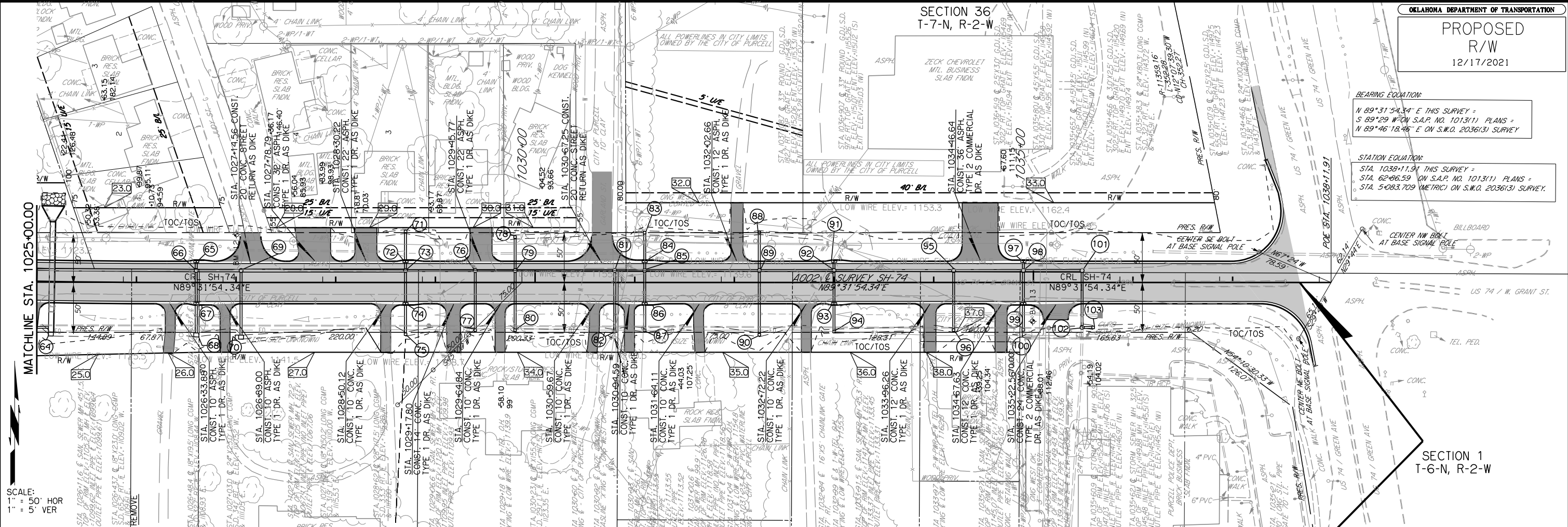

SCALE: 1" = 50' HOR 1" = 5' VER

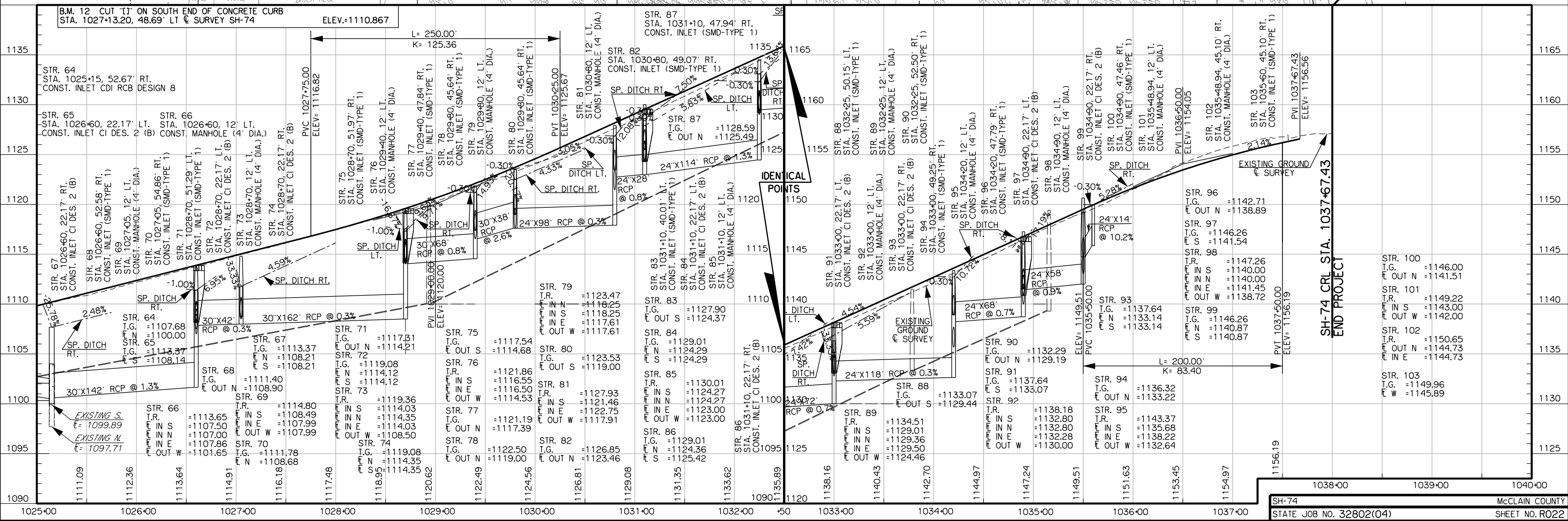

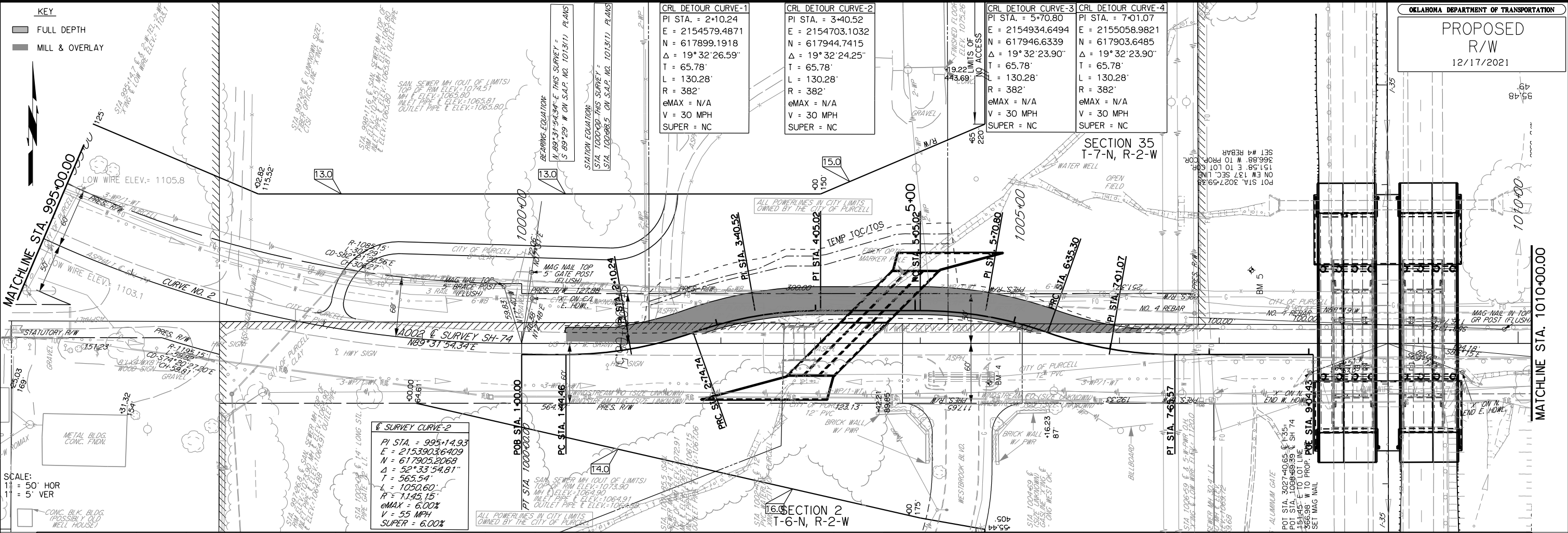

KEY
 FULL DEPTH
 MILL & OVERLAY

SCALE:
 1" = 50' HOR
 1" = 5' VER

SURVEY CURVE-2
 PI STA. = 995+14.93
 E = 2153903.6409
 N = 617905.2068
 Δ = 52°33'54.81"
 L = 1050.60'
 R = 1145.15'
 eMAX = 6.00%
 V = 55 MPH
 SUPER = 6.00%

CRL DETOUR CURVE-1
 PI STA. = 2+10.24
 E = 2154579.4871
 N = 617899.1918
 Δ = 19°32'26.59"
 L = 65.78'
 R = 382'
 eMAX = N/A
 V = 30 MPH
 SUPER = NC

CRL DETOUR CURVE-2
 PI STA. = 3+40.52
 E = 2154703.1032
 N = 617944.7415
 Δ = 19°32'24.25"
 L = 65.78'
 R = 382'
 eMAX = N/A
 V = 30 MPH
 SUPER = NC

CRL DETOUR CURVE-3
 PI STA. = 5+70.80
 E = 2154934.6494
 N = 617946.6339
 Δ = 19°32'23.90"
 L = 65.78'
 R = 382'
 eMAX = N/A
 V = 30 MPH
 SUPER = NC

CRL DETOUR CURVE-4
 PI STA. = 7+01.07
 E = 2155058.9821
 N = 617903.6485
 Δ = 19°32'23.90"
 L = 65.78'
 R = 382'
 eMAX = N/A
 V = 30 MPH
 SUPER = NC

B.M. 4 CUT "T" IN SE CORNER OF EAST HEADWALL
 STA. 1004+69.54, 39.05' RT & SURVEY SH-74 ELEV.=1074.939

B.M. 5- ODOT ALUMINUM CAP IN CONCRETE
 STA. 3028+15, 137' LT & SURVEY I-35 ELEV.= 1076.195

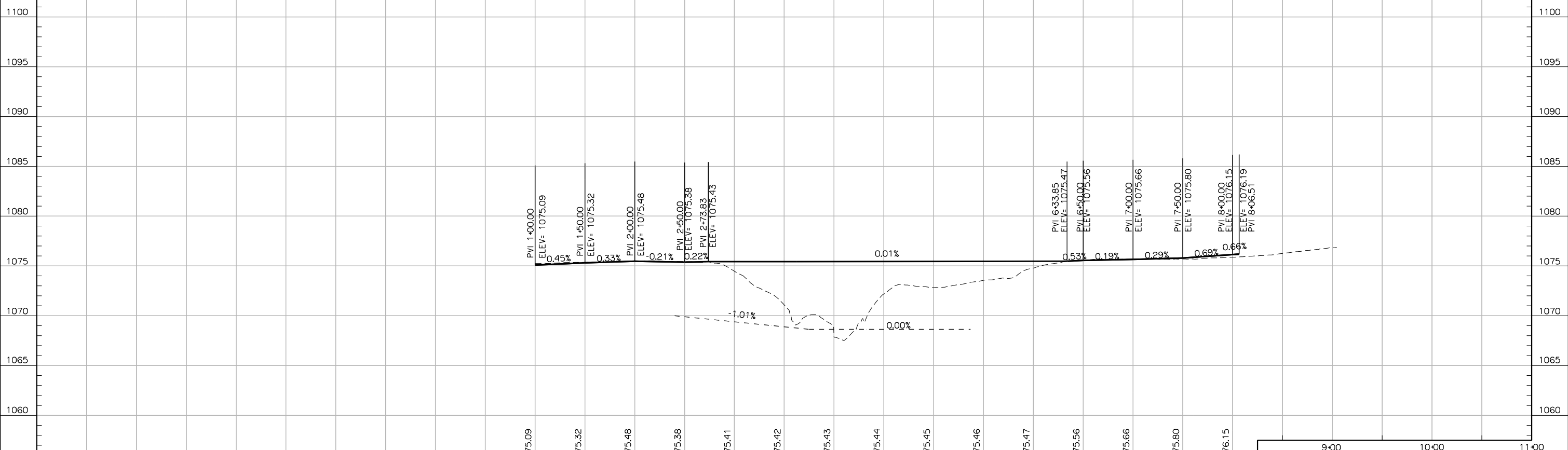

SURVEY CONTROL DATA

1. POSITIONAL CONTROL:

- A. POSITIONAL CONTROL FOR THIS SURVEY IS THE NGS OKLAHOMA STATE PLANE COORDINATE SYSTEM, NAD83 (2011), LAMBERT PROJECTION (SOUTH ZONE).
- B. ACCURACY - THE POSITIONAL CONTROLS FOR THIS SURVEY MEETS OR EXCEEDS THE FOLLOWING ACCURACY CRITERIA:
1. NETWORK ACCURACY: 0.10 FOOT
 2. LOCAL ACCURACY: 0.05 FOOT

2. BEARINGS:

THE BEARINGS SHOWN HEREIN OR HEREON ARE GRID BEARINGS DERIVED FROM THE NGS OKLAHOMA STATE PLANE COORDINATE SYSTEM AND ARE NOT ASTRONOMICAL. THE ANGLE OF VARIANCE BETWEEN GRID NORTH (GN) AND THE ASTRONOMICAL TRUE NORTH (TN) IS DEPICTED DIAGRAMMATICALLY.

3. VERTICAL CONTROLS:

- A. LEVEL DATUM IS NAVD 88 FROM STATIC GPS.
- B. ACCURACY - VERTICAL CONTROL FOR THIS SURVEY MEETS OR EXCEEDS THE FOLLOWING ACCURACY CRITERIA:
1. NETWORK ACCURACY (FROM GPS OR LEVELING): 0.10 FOOT
 2. LOCAL ACCURACY (CONFIRMED BY LEVELING): 0.02 FOOT

SURVEY BEGAN: October 30, 2018
 SURVEY COMPLETED: September 5, 2019

SURVEY CREW MEMBERS:

Shawn Smith, Professional Land Surveyor II
 Charles W. Pauley, Transportation Specialist Level VI
 Jimmie R. Wallace, Transportation Specialist Level IV
 Kristy D. Henderson, Transportation Specialist Level IV
 Robert R. Barthelemy, Transportation Specialist Level IV
 Corey R. Goshe, Transportation Specialist Level IV

EQUIPMENT:

Leica MS60 Total Station
 Leica GS15 GPS Sensors
 Wild NA-2 Automatic Level
 Leica DNA-10 Electronic Level
 Leica CS15 & CS20 Data Collectors



SURVEY DATA SHEETS 1" = 50'
 GEOMETRIC DATA SHEETS 1" = 500'

SURVEY EXTENTS

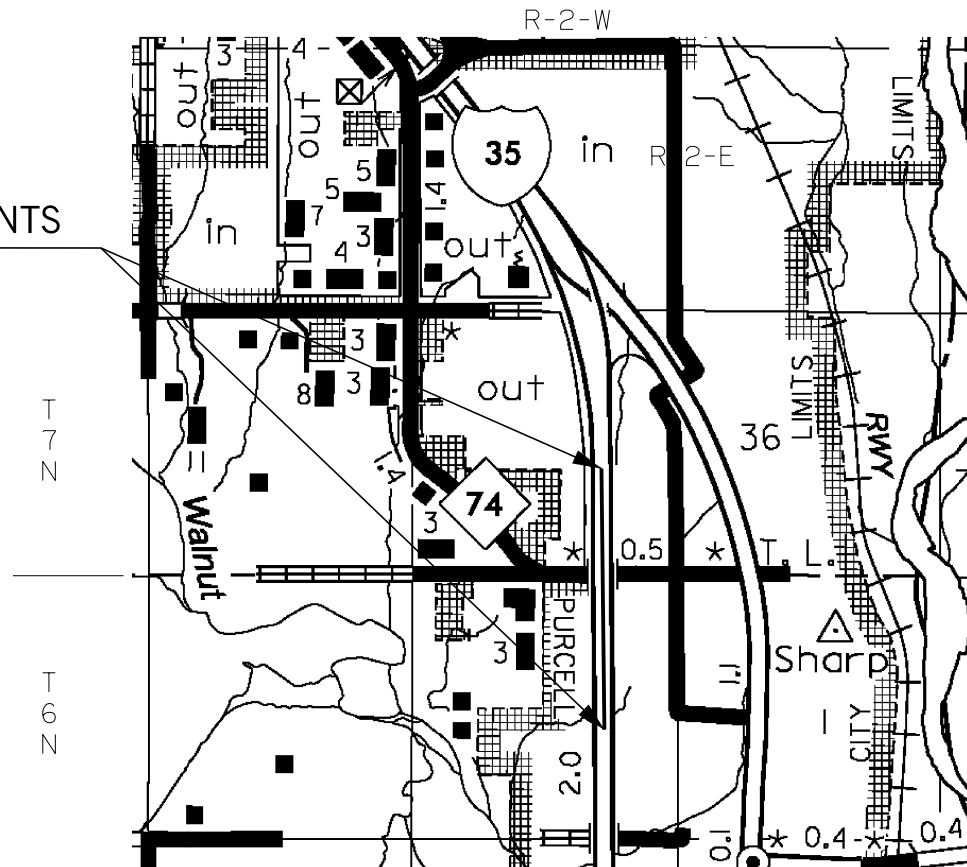

PROJECT LENGTH 4707.28 Ft. 0.89 MI.

BEGINNING STATION : 3000+00.00
 ENDING STATION : 3047+07.28



Electronic File Transfer Disclaimer:

These Files, Drawings and/or Notes are provided for information only. The Oklahoma Department of Transportation (ODOT) and the Owner cannot be held responsible for the content or accuracy of these Files, Drawings and/or Notes due to conversions, software translations, or any other manipulation of said Files, Drawings and/or Notes. ODOT expressly disclaims any responsibility arising from any use of these Files, Drawings and/or Notes. To the full extent permitted by applicable law, the recipient of these Files, Drawings and/or Notes hereby agrees to defend, indemnify, and hold harmless ODOT and the Owner from and against any and all claims, suits, actions, damages, loss, liability or costs of every nature or description (including reasonable attorney's fees) arising from, or in any way attributable to or connected with any of these Files, Drawings and/or Notes.

SURVEY DATA SHEETS

McCLAIN COUNTY

I - 35

SWO 5398(1)
 STATE JOB NO. 32802(04)

I-35 SOUTHBOUND RAMP AT SH 74W IN PURCELL

INDEX OF SURVEY SHEETS

S001.	TITLE SHEET
S002-S008.	SURVEY REPORTS
S009-S019.	SURVEY DATA SHEETS
S020-S021.	LAND TIE DATA SHEETS

utility company owner's list

"CALL BEFORE YOU DIG"
 THE NEW NATIONAL LOCATE NUMBER
 811

Windstream Comm. Okla. City, Ok. 1-405-228-2530
 C.T.S.I. Stillwater, Ok. 1-800-927-2027
 Trace Fiber Inc. Tulsa, Ok. 1-855-899-8686
 Level 3 Comm. Broomfield, Co. 1-877-453-8353
 ONS OK West 1-800-664-5463
 City of Purcell 1-405-527-6561

STATE OF OKLAHOMA
 DEPARTMENT OF TRANSPORTATION

SWO 5398(1) Job/Piece 32802 (04) Engr. Contract No. _____

LAND SURVEYOR'S CERTIFICATION

I hereby certify that all land and property sub-division distances, angles, corners and monumentation made or used in conjunction with this survey and depicted or recorded herein or hereon were recovered, established or re-established in substantial conformity with:

- applicable instructions contained in the U.S. Government Bureau of Land Management publication "Manual of Surveying Instructions";
- its supplement, "Restoration of Lost or Obliterated Corners and Subdivision of Sections";
- "Oklahoma Minimum Standards for the Practice of Land Surveying" as adopted by the State Board of Registration for Professional Engineers and Land Surveyors; and
- sound land surveying practices;

including a thorough search, study, analysis and consideration of all existing records and field evidence.

I further certify that all survey monuments depicted exist and that all land survey work was done by me or under my direct supervision and that it is true, accurate and correct to the best of my knowledge and belief.

Dated this 14th day of July, 2020.

Land Surveyor Shawn Smith (seal)
 Signature
 Shawn Smith
 Printed Name



Oklahoma Registered Land Surveyor No. 1663

Certificate of Authorization No. _____ Exp. Date _____

PLS	SMS
DRAWN	SMS
CHECKED	SMS
APPROVED	DEA
CREW	TECUMSEH

OKLAHOMA DEPARTMENT OF TRANSPORTATION
 SURVEY DIVISION

SURVEY DATA SHEET

SWO 5398(1)

SPECIFICATIONS FOR SURVEYS FOR PRIMARY AND SECONDARY HIGHWAYS DATED JANUARY, 2018 GOVERN.

OKLAHOMA DEPARTMENT OF TRANSPORTATION

SURVEY DIVISION (405) 521-2621 FAX (405) 522-0364

Date: September 5, 2019
 To: Mr. Kyle King, Chief of Surveys
 From: Shawn Smith, Professional Land Surveyor
 Subject: SWO 5398(1) – J/P No. 32802(04) – I-35 – Southbound ramp at S.H. 74W in Purcell.

I. General:
 Survey Began: October 30, 2018
 Survey Completed: September 5, 2019

The measurement unit for this project was the U.S. Survey Foot.

II. Assignment:
 This survey was assigned to and completed by the Tecumseh field crew.

III. Purpose of Survey:
 The purpose of this survey was to develop plans for a southbound ramp from I-35 to S.H. 74.

IV. Survey Limits:
 Survey began at the POT Sta. 1428+00 and ended at PT sta. 1380+92.72 per FAP No. I-35-2(13)091 plans and SWO2170(1) survey.

V. Alignment:
 The centerline of survey was re-established along the existing I-35 as shown on FAP No. I-35-2(13)091 plans and SWO2170(1) survey.

VI. Stationing:
 Due to existing stationing running opposite of standard, new stationing was established assigning Sta. 3000+00.00 at existing Sta. 1428+00 and Sta. 3047+07.28 at Sta. 1380+92.72.

SWO 5398(1) I-35 McClain County
 Historical Letter & Written Report
 Page 2 of 4

VII. Horizontal Control:
 Horizontal control for this survey is the Oklahoma State Plane Coordinate System, NAD 83(2011), Lambert Projection, South Zone, from ODOT monuments established in SWO4130(1), SWO4331(1) and SWO4976(1) surveys. Static sessions were collected and processed in OPUS Projects to verify positions.

VIII. Vertical Control:
 Vertical control was taken from static sessions processed in OPUS Projects utilizing new control along with ODOT monument M-44-541. Level Datum is NAVD 88.

IX. Photo Controls:
 Aerial control targets were established by consultant.

X. Topography and DTM:
 Topography and DTM data were collected by aerial imagery provided by consultant and supplemented by conventional field methods.

XI. Land Ties:
 Complete land tie information was obtained by conventional field methods within Sections 1 and 2, Township 6 North, Range 2 West, I.M. and Sections 35 and 36, Township 7 North, Range 2 West, I.M.

XII. Existing Right of Way:
 The right of way along I-35 and S.H. 74 was established from existing plans, right of way documents and right of way occupation. Right of way documents were acquired from ODOT right of way division along with the McClain County courthouse. Statutory right of way in this area is 16.5 feet each side. A search was made to determine if additional right of way had been taken, but none was found.

XIII. Utilities:
 Call OKIE was contacted throughout the course of this project. All utilities marked, along with any overhead lines, are depicted on the submitted digital file.

XIV. Potential Environment Contamination:
 During the course of the survey, the project site was carefully checked for any areas of environmental concern. No areas were found.

SWO 5398(1) I-35 McClain County
 Historical Letter & Written Report
 Page 3 of 4

XV. Drainage:
 Drainage areas for all drains crossing the Survey Centerline were taken from USGS quad maps that have been scanned into a Microstation Design File.

High water information was gathered by conventional field methods. The results are shown on the submitted digital file.

XVI. Survey Data Sheets:
 Survey Data Sheets were submitted in the form of a Microstation Design File as per ODOT Survey Division Standards. These were incorporated into a set of design drawings and are in substantial conformity with the ODOT Survey Division Standards for Survey Data Sheets.

XVII. Submission of Survey Data:

- 1 Survey Data Sheets
- 2 Historical Letter & Written Report
- 3 Form SD-7, Public and Privately Owned Utilities List
- 4 Form SD-9, Final Cost Report of Survey
- 5 Form SD-11, Survey Control Monument Record
- 6 Form SD-20, Survey Control Data Statement
- 7 Form SD-41, Surveyor's Certification
- 8 Cogo Point List
- 9 Alignment Report
- 10 Benchmark & Check Levels List
- 11 Oklahoma Certified Corner Record Forms
- 12 Ownership List
- 13 OSSDA Field Form

PLS	SMS		OKLAHOMA DEPARTMENT OF TRANSPORTATION SURVEY DIVISION				
DRAWN	SMS		SURVEY DATA SHEET SWO 5398(1)				
CHECKED	SMS						
APPROVED	DEA						
CREW	TECUMSEH						
COUNTY	McCLAIN	HIGHWAY	I-35	STATE JOB NO.	32802(04)	SHEET NO.	S002

SWO 5398(1) I-35 McClain County
 Historical Letter & Written Report
 Page 4 of 4

XVIII. Personnel:

Shawn Smith, PLS	Professional Land Surveyor Lv. II
Charles W. Pauley,	Transportation Specialist Lv. VI
Jimmie R. Wallace, Jr.,	Transportation Specialist Lv. IV
Corey R. Goshe,	Transportation Specialist Lv. IV
Robert R. Barthelemy,	Transportation Specialist Lv. IV
Kristy D. Henderson,	Transportation Specialist Lv. IV

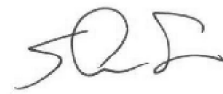

Shawn Smith, PLS
 ODOT Survey Division
 Tecumseh Survey Office

STATE OF OKLAHOMA S.D. FORM NO. 11
 DEPARTMENT OF HIGHWAYS REVISED 01/01/2015
 SURVEY DIVISION
 POSITION AND DESCRIPTION OF SURVEY MONUMENTS

COUNTY McClain Monument Number M-44-842 SWO 5398(1) DATE 12-26-2018

TYPE OF MONUMENT Aluminum Cap in concrete MONUMENT SET FOR Primary control

WRITTEN DESCRIPTION OF LOCATION: From the Jct. of SH 39W and Interstate 35.
Monument is approx. 1.85 mi. north along I-35 and approx. 27' east of west R/W fe.
and approx. 87' west of an asph. shld. Metal survey sign 27' W in R/W fe. line

ESTABLISHED BY: Shawn Smith PLS

COORDINATE SYSTEM: Oklahoma State Plane ZONE: South
 COORDINATES (FEET) X 2156226.07011 Y 615306.47608

GEODETIC POSITION
 LATITUDE 35°01'20.95734" NORTH
 LONGITUDE 97°22'34.84883" WEST
 ELLIPSOIDAL HEIGHT 1009.240
 METHOD USED TO ESTABLISHED: GPS Static (OPUS Projects Beta)

SOURCE: NAD83(2011)

ORTHOMETRIC HEIGHT
1095.057 FEET GEOID MODEL: 12B GEOID SEPARATION: -85.817 FEET
 METHOD USED TO ESTABLISHED: GPS Static (OPUS Projects Beta), Differential Leveling

SOURCE: NAVD83

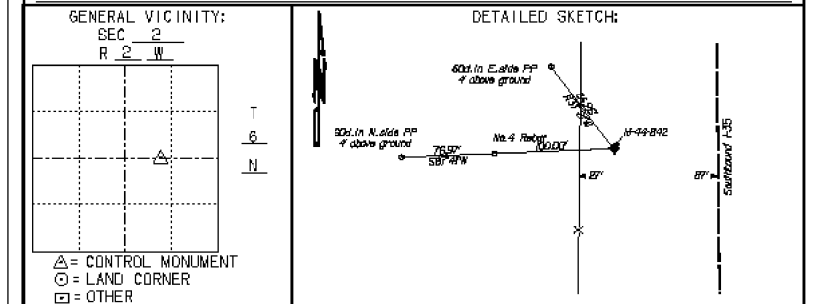

PLS	SMS	OKLAHOMA DEPARTMENT OF TRANSPORTATION SURVEY DIVISION					
DRAWN	SMS						
CHECKED	SMS						
APPROVED	DEA						
CREW	TECUMSEH						
SURVEY DATA SHEET							
SWO 5398(1)							
COUNTY	McCLAIN	HIGHWAY	I-35	STATE JOB NO.	32802(04)	SHEET NO.	S003

STATE OF OKLAHOMA S.D. FORM NO. 11
 DEPARTMENT OF HIGHWAYS REVISED 01/01/2015
 SURVEY DIVISION
 POSITION AND DESCRIPTION OF SURVEY MONUMENTS

COUNTY McCain Monument Number M-44-B43 SWO 5398(1) DATE 12-26-2018

TYPE OF MONUMENT Aluminum Cap In concrete MONUMENT SET FOR Primary control

WRITTEN DESCRIPTION OF LOCATION: From the Jct. of SH 39W and Interstate 35.
Monument is approx. 3.0 mi. north along I-35 and approx. 28' east of E edge N I-35.
and approx. 13' west of W edge asph. exit lane. Metal survey sign 1' N. of mon.

ESTABLISHED BY: Shawn Smith PLS

COORDINATE SYSTEM: Oklahoma State Plane ZONE: South
 COORDINATES (FEET) X 2155333.28447 Y 622510.54827

GEODETTIC POSITION

LATITUDE 35°02'32.25402" NORTH
 LONGITUDE 97°22'33.02364" WEST
 ELLIPSOIDAL HEIGHT 1045.231

METHOD USED TO ESTABLISHED: GPS Static (OPUS Projects Beta)

SOURCE: NAD83(2011)

ORTHOMETRIC HEIGHT

1131.146 FEET GEOID MODEL: 12B GEOID SEPRATION: -65.915 FEET
 METHOD USED TO ESTABLISHED: GPS Static (OPUS Projects Beta), Differential Leveling

SOURCE: NAVD83

GENERAL VICINITY:
 SEC 35
 R 2 W

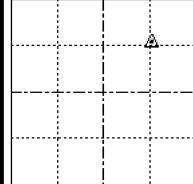

T
7
N

△ = CONTROL MONUMENT
 ○ = LAND CORNER
 □ = OTHER

DETAILED SKETCH:

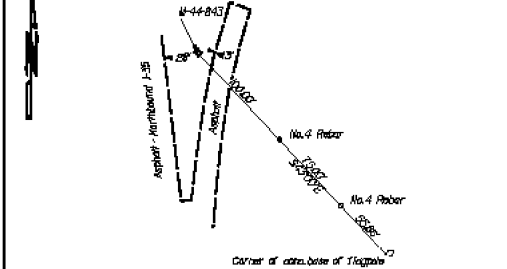

Corner of centerline of Highway

STATE OF OKLAHOMA S.D. FORM NO. 11
 DEPARTMENT OF HIGHWAYS REVISED 01/01/2015
 SURVEY DIVISION
 POSITION AND DESCRIPTION OF SURVEY MONUMENTS

COUNTY McCain Monument Number M-44-B44 SWO 5398(1) DATE 12-26-2018

TYPE OF MONUMENT Aluminum Cap In concrete MONUMENT SET FOR Primary control

WRITTEN DESCRIPTION OF LOCATION: From the Jct. of SH 74 and N. Green Ave.
Monument is approx. 0.6 mi. west along SH 74 and approx. 21' N. of N. R/W of SH 74
and approx. 72' north of C. SH 74. Metal survey sign 21' S in fe. line

ESTABLISHED BY: Shawn Smith PLS

COORDINATE SYSTEM: Oklahoma State Plane ZONE: South
 COORDINATES (FEET) X 2155200.97172 Y 617909.34800

GEODETTIC POSITION

LATITUDE 35°01'47.49472" NORTH
 LONGITUDE 97°22'34.95140" WEST
 ELLIPSOIDAL HEIGHT 990.342

METHOD USED TO ESTABLISHED: GPS Static (OPUS Projects Beta)

SOURCE: NAD83(2011)

ORTHOMETRIC HEIGHT

1076.195 FEET GEOID MODEL: 12B GEOID SEPRATION: -65.653 FEET
 METHOD USED TO ESTABLISHED: GPS Static (OPUS Projects Beta), Differential Leveling

SOURCE: NAVD83

GENERAL VICINITY:
 SEC 35
 R 2 W

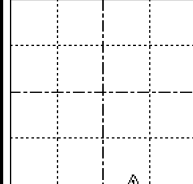

T
7
N

△ = CONTROL MONUMENT
 ○ = LAND CORNER
 □ = OTHER

DETAILED SKETCH:

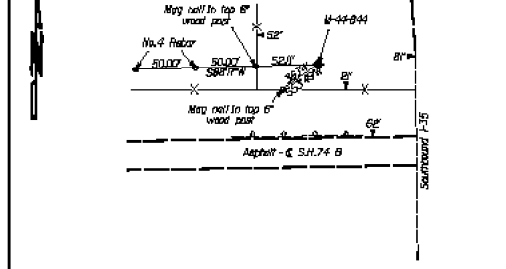

STATE OF OKLAHOMA S.D. FORM NO. 11
 DEPARTMENT OF HIGHWAYS REVISED 01/01/2015
 SURVEY DIVISION
 POSITION AND DESCRIPTION OF SURVEY MONUMENTS

COUNTY McCain Monument Number M-44-B45 SWO 5398(1) DATE 12-26-2018

TYPE OF MONUMENT Aluminum Cap In concrete MONUMENT SET FOR Primary control

WRITTEN DESCRIPTION OF LOCATION: From the Jct. of SH 74 and N. Green Ave.
Monument is approx. 300' west along SH 74 and approx. 40' south of C. SH 74
and approx. 10' west of W. edge of conc dr. Metal survey sign 1' south of mon.

ESTABLISHED BY: Shawn Smith PLS

COORDINATE SYSTEM: Oklahoma State Plane ZONE: South
 COORDINATES (FEET) X 2157901.82248 Y 617899.53848

GEODETTIC POSITION

LATITUDE 35°01'46.43522" NORTH
 LONGITUDE 97°22'01.51978" WEST
 ELLIPSOIDAL HEIGHT 1062.882

METHOD USED TO ESTABLISHED: GPS Static (OPUS Projects Beta)

SOURCE: NAD83(2011)

ORTHOMETRIC HEIGHT

1140.735 FEET GEOID MODEL: 12B GEOID SEPRATION: -65.653 FEET
 METHOD USED TO ESTABLISHED: GPS Static (OPUS Projects Beta), Differential Leveling

SOURCE: NAVD83

GENERAL VICINITY:
 SEC 1
 R 2 W

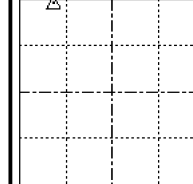

T
6
N

△ = CONTROL MONUMENT
 ○ = LAND CORNER
 □ = OTHER

DETAILED SKETCH:

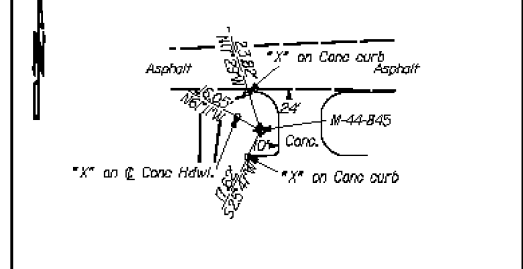

PLS	SMS	OKLAHOMA DEPARTMENT OF TRANSPORTATION SURVEY DIVISION
DRAWN	SMS	
CHECKED	SMS	
APPROVED	DEA	
CREW	TECUMSEH	
COUNTY <u>McCLAIN</u> HIGHWAY <u>I-35</u> STATE JOB NO. <u>32802(04)</u> SHEET NO. <u>S004</u>		SURVEY DATA SHEET SWO 5398(1)

CHECK LEVELS						BENCHMARK LIST		NAVD 88 DATUM SHEET 1 OF 2
SWO 5398(1)	BM NO.	RUN 1	RUN 2	MEAN DIFF.	ADI. DIFF.	ADI. ELEV.	PUBLISHED ELEV.	BM DESCRIPTION
M-44-842	BM 1						1095.057	ODOT Aluminum Cap in Concrete. 141' LT Sta. 3001+31
	TO	0.962	0.976	0.969	0.952			
	BM 2					1096.009		Top of Delineator Post. 173' LT Sta. 3009+09
	TO	7.067	7.066	7.067	7.050			
	BM 3					1103.059		Railroad Spike in 6" Brace Post. 173' LT Sta. 3015+92
	TO	-28.097	-28.110	-28.104	-28.120			
	BM 4					1074.939		Cut 'I' in SE Corner of East Headwall. 39' RT Sta. 1004+70
	TO	1.272	1.274	1.273	1.256			
M-44-844	BM 5					1076.195	1076.195	ODOT Aluminum Cap in Concrete. 137' LT Sta. 3028+15
	TO	7.851	7.855	7.853	7.860			
	BM 6					1084.055		Railroad Spike in 6" Brace Post. 167' LT Sta. 3036+07
	TO	18.050	18.059	18.055	18.061			
	BM 7					1102.116		Cut 'I' on NE Corner of Concrete Pedestal. 116' LT Sta. 3046+80
	TO	15.401	15.411	15.406	15.413			
	BM 8					1117.529		Railroad Spike in 6" Brace Post. Outside of survey limits.
	TO	24.407	24.402	24.405	24.411			
	BM 9					1141.940		Top of Delineator Post. Outside of survey limits.
	TO	-10.806	-10.795	-10.801	-10.794			
M-44-843	BM 10					1131.146	1131.146	ODOT Aluminum Cap in Concrete. Outside of survey limits.

M-44-844	BM 5					1076.195		ODOT Aluminum Cap in Concrete. 137' LT Sta. 3028+15
	TO	9.826	9.830	9.828	9.842			
	BM 11					1086.037		Cut 'I' on NE Corner of West Headwall. 168' LT Sta. 1015+86
	TO	24.817	24.816	24.817	24.830			
	BM 12					1110.867		Cut 'I' on South End of Concrete Curb. 48' LT Sta. 1027+13
	TO	37.854	37.855	37.855	37.868			
M-44-845	BM 13					1148.735	1148.735	ODOT Aluminum Cap in Concrete. 39' RT Sta. 1035+12

U:\SW06398(1)_IP32802(04)\Final\report\sw06398_1_v1_logo.txt Tuesday, July 14, 2020 2:38 PM

Report Results

PT#	EASTING	NORTHING	ELEV
1	2155226.00200	615306.45600	1095.06
2	2155186.14700	616083.47900	1096.01
3	2155177.91900	616766.81900	1103.06
4	2154939.00100	617874.60900	1074.94
5	2155200.85000	617989.34800	1076.19
6	2155161.47100	618781.86000	1084.06
7	2155200.57700	619854.43800	1102.12
8	2155094.71300	620871.36100	1117.53
9	2154915.78800	622046.75400	1141.94
10	2155333.17600	622518.58300	1131.15
11	2156054.07400	618090.87900	1086.04
12	2157181.97500	617980.32400	1110.87
13	2157981.73300	617899.53800	1148.73
300	2155368.84499	613176.44951	
301	2155367.55848	615292.71264	
302	2155357.77999	616176.38229	
303	2155346.71479	617176.32707	
304	2155338.51940	617916.93339	
305	2155338.31219	617935.65882	
306	2155324.58458	619176.20463	
307	2155316.79085	619880.51349	
308	2154469.15808	617909.82853	
309	2154732.16299	617911.97794	
310	2154851.55110	617912.95264	
311	2154971.54757	617913.93431	
312	2155489.96711	617918.17110	
313	2155820.93394	617920.94131	
314	2155993.91372	617922.28961	
315	2156193.90702	617923.92406	
316	2156393.89073	617925.55843	
317	2156469.09130	617926.17301	
318	2156493.88902	617926.17301	
319	2156813.88048	617928.99080	
320	2157077.37434	617931.14421	
321	2157145.24275	617931.69887	
322	2157365.23762	617933.49678	
323	2157469.05790	617934.34525	
324	2157565.55794	617935.11390	
325	2157740.55386	617936.56406	
326	2157868.85587	617937.61261	
327	2157968.85353	617938.42984	
328	2150184.60172	617939.76408	
329	2158280.92668	617940.98034	
330	2158352.94009	616613.75510	
331	2152659.36473	619397.29342	
332	2152859.97330	619245.71136	
333	2153014.48820	619047.31400	
334	2153856.21703	618381.44402	
335	2153903.64094	617908.20683	
336	2154166.05815	617907.35144	
337	2153885.95861	617927.91831	
338	2154165.76073	617948.18392	
339	2154246.59087	617929.81338	
340	2155375.48406	614576.48624	
341	2155301.90112	621226.07913	
342	2155273.22692	623817.32847	
343	2152819.30579	626896.07515	
344	2155288.02385	620574.99664	
345	2155309.10475	620575.09688	
346	2154782.67349	623213.64667	

-1-

PLS	SMS	OKLAHOMA DEPARTMENT OF TRANSPORTATION SURVEY DIVISION					
DRAWN	SMS						
CHECKED	SMS						
APPROVED	DEA						
CREW	TECUMSEH						
COUNTY	McCLAIN	HIGHWAY	I-35	STATE JOB NO.	32802(04)	SHEET NO.	S005

SURVEY DATA SHEET

SWO 5398(1)

U:\S\W06388(1)_JP32802(04)\Final\report\sw06388_1_v1_loggo.txt Tuesday, July 14, 2020 2:38 PM

8101	2155995.39989	617578.11917
8102	2155994.71170	617739.16846
8109	2156829.71406	617738.28501
8104	2155820.87525	617938.24262
8105	2155828.85943	617938.28218
8106	2155895.87418	617938.64419
8107	2155910.84136	617938.72433
8108	2155993.84017	617939.16874
8109	2156192.83730	617940.21959
8110	2156195.37562	617580.24287
8111	2156395.84666	617378.31403
8112	2156395.12111	617581.31274
8113	2156495.11968	617581.84816
8114	2156392.82443	617941.31044
8115	2156492.82300	617941.84586
8116	2156815.11509	617583.56152
8117	2156816.19127	617282.46001
8118	2157079.68937	617283.46006
8119	2157392.55722	617284.64748
8120	2157391.26565	617645.96517
8121	2157366.26562	617645.87029
8122	2157366.17549	617671.09074
8123	2157366.50788	617578.09134
8124	2157146.51020	617577.08198
8125	2157039.82603	617944.59614
8126	2157077.32564	617944.76820
8127	2157145.19493	617945.07960
8128	2157365.19261	617946.08899
8129	2157565.51550	617947.00811
8130	2157573.42042	617947.04438
8131	2157740.51366	617947.81103
8132	2157566.40902	617697.00970
8133	2157566.49838	617672.00986
8134	2157741.40719	617697.81263
8135	2157742.87914	617285.97705
8136	2157871.18328	617286.46400
8137	2157869.56791	617738.40105
8138	2157869.06751	617878.40016
8139	2157969.56686	617738.85987
8140	2157969.06646	617878.85897
8141	2157868.81791	617948.39971
8142	2157968.81626	617948.85853
8143	2157971.18251	617286.84352
8144	2158137.33529	617287.47412
8145	2157750.68854	617986.64855
8146	2157746.06420	618931.62730
8147	2157839.84109	618332.38721
8148	2157827.95663	618502.37676
8149	2157567.28867	618500.16473
8150	2157522.99914	617984.78776
8151	2157520.89298	618174.77608
8152	2157448.44540	618174.18400
8153	2157450.55186	617984.19568
8154	2157375.08408	617983.57892
8155	2157372.97792	618173.56724
8156	2157295.50051	618172.93406
8157	2157297.60667	617982.94573
8158	2157217.59780	617982.29186
8159	2157150.58227	618171.74971
8160	2157095.25740	618208.20824
8161	2156967.35848	618150.51969
8162	2156987.28288	618093.89825
8163	2157121.93541	618132.78753
8164	2157148.61343	618057.36682

U:\S\W06388(1)_JP32802(04)\Final\report\sw06388_1_v1_loggo.txt Tuesday, July 14, 2020 2:38 PM

8165	2157007.19933	618037.30538
8166	2157027.10784	617980.73508
8167	2157175.29144	617981.94611
8168	2156947.53902	618206.83097
8169	2156805.97081	618291.53784
8170	2156663.75110	618460.74817
8171	2156434.64403	618243.53226
8172	2156228.66698	618242.42939
8173	2156092.49623	618241.70029
8174	2156092.39510	618160.55134
8175	2156229.19690	618160.43114
8176	2156229.71390	618080.43281
8177	2156094.28120	618080.55624
8178	2156095.01056	618014.71028
8179	2156120.28710	617989.84567
8180	2156230.29553	617990.43469
8181	2155910.28755	617988.72127
8182	2156020.28772	617989.31024
8183	2156045.01046	618014.44237
8184	2156044.28364	618080.05854
8185	2155909.29070	618078.71574
8186	2155908.40461	618158.71084
8187	2156043.39755	618160.05363
8188	2156042.51146	618240.04873
8189	2155907.51852	618238.70593
8190	2155903.53317	618598.49771
8191	2155898.43609	619058.65563
8192	2156801.41314	619063.49041
8193	2155888.91680	619918.04463
8194	2155506.40793	619916.16892
8195	2155481.01087	618996.29833
8196	2155812.76970	618598.03056
8197	2155814.62072	618519.00895
8198	2155889.61965	618519.41052
8199	2154167.61909	617579.24559
8200	2153959.33939	617484.78580
8201	2153958.21023	617719.54308
8202	2153749.46308	617718.45212
8203	2153748.45902	617927.19971
8204	2153957.20616	617928.29067
8205	2153416.55447	618449.43922
8206	2153168.77138	618261.44120
8207	2153089.70793	618262.99216
8208	2153335.61682	618553.39678
8209	2152828.40363	619183.27694
8210	2152880.26591	618981.68004
8211	2152610.29916	618985.51028
8212	2152197.32103	619398.43286
8213	2152193.27861	619686.80453
8214	2152827.11317	619322.96864
8215	2152821.75447	619903.04646
8216	2154148.67182	619909.49627
8217	2154165.12176	618010.56704
9001	2151537.83991	612629.08002
9002	2154191.14101	612636.59952
9003	2156842.88991	612654.62282
9004	2159480.07577	612650.15131
9005	2159467.73494	615302.91827
9006	2156823.27511	615300.48912
9007	2154178.53110	615286.36572
9008	2151526.01401	615272.20682
9009	2151514.14871	617915.52272
9010	2154165.95321	617929.38162
9011	2156813.82841	617943.55922

U:\S\W06388(1)_JP32802(04)\Final\report\sw06388_1_v1_loggo.txt Tuesday, July 14, 2020 2:38 PM

9012	2159455.39411	617955.67922
9013	2159425.89661	620594.98257
9014	2156784.87811	620682.11032
9015	2154138.91132	620569.53448
9016	2151492.39991	620556.95462
9017	2151468.60741	623206.28962
9018	2154111.85621	623210.96802
9019	2156756.88941	623221.52992
9020	2159396.39911	623234.28592

PLS	SMS	OKLAHOMA DEPARTMENT OF TRANSPORTATION SURVEY DIVISION
DRAWN	SMS	
CHECKED	SMS	
APPROVED	DEA	
CREW	TECUMSEH	
COUNTY <u>McCLAIN</u> HIGHWAY <u>I-35</u> STATE JOB NO. <u>32802(04)</u> SHEET NO. <u>S007</u>		SURVEY DATA SHEET SWO 5398(1)

Horizontal Alignment Review Report

Report Created: 7/20/2020
Time: 9:21am

Project: swo5398_1_v2
Description: swo5398_1_v2
File Name: C:\S\W\O\5398(1)_IP32802(04)\Summer 2020 Revision\civil\swswo5398_1_v2.alg
Last Revised: 325248 7/20/2020 9:20:48 AM
Input Grid Factor: 1.0000000 Note: All units in this report are in feet unless specified otherwise.

Alignment Name: A001
Alignment Description: CL I 35
Alignment Style: Centerline

	Station	Northing	Easting
Element: Linear			
POB (340)	2994+00.00	814576.48824	2155375.48408
POE (307)	3047+04.35	819880.51349	2155316.79085
Tangential Direction:	N 0°38'02.39" W		
Tangential Length:	5304.35		

Alignment Name: A002
Alignment Description: CL SH 74
Alignment Style: Centerline

	Station	Northing	Easting
Element: Circular			
PC ()	975+87.50	819397.29342	2152859.38473
PI ()	978+18.94	819245.71136	2152859.97330
CC ()	980+67.49	817875.78556	2151508.88139
PT ()	980+67.49	819047.31400	2153014.43820
Radius:	1907.04		
Delta:	15°01'18.78" Right		
Degree of Curvature (Aro):	3°00'16.04"		
Length:	499.99		
Tangent:	251.44		
Chord:	498.58		
Middle Ordinate:	16.38		
External:	16.50		
Tangent Direction:	S 52°55'29.84" E		
Radial Direction:	S 37°04'30.38" W		
Chord Direction:	S 45°24'50.25" E		
Radial Direction:	S 52°05'49.14" W		
Tangent Direction:	S 37°54'10.88" E		

Element: Linear			
PT ()	980+67.49	819047.31400	2153014.43820

PC ()	989+49.40	818351.44402	2153556.21703
Tangential Direction:	S 37°54'10.88" E		
Tangential Length:	881.91		
Element: Circular			
PC ()	989+49.40	818351.44402	2153556.21703
PI ()	995+14.93	817905.20883	2153903.64094
CC ()	1000+00.00	819054.94029	2154456.79964
PT ()	1000+00.00	817909.82853	2154466.15808
Radius:	1145.15		
Delta:	52°33'54.81" Left		
Degree of Curvature (Aro):	5°00'12.03"		
Length:	1050.00		
Tangent:	505.54		
Chord:	1014.14		
Middle Ordinate:	118.38		
External:	132.03		
Tangent Direction:	S 37°54'10.88" E		
Radial Direction:	S 52°05'49.14" W		
Chord Direction:	S 64°11'08.26" E		
Radial Direction:	S 0°28'05.88" E		
Tangent Direction:	N 89°31'54.34" E		

Element: Linear			
PT ()	1000+00.00	817909.82853	2154466.15808
POE (329)	1038+11.91	817940.98034	2158280.93688
Tangential Direction:	N 89°31'54.34" E		
Tangential Length:	3811.91		

Alignment Name: A003
Alignment Description: CL Northbound Lane
Alignment Style: Centerline

	Station	Northing	Easting
Element: Linear			
POB (307)	3047+04.35	819880.51349	2155316.79085
POE (341)	3060+50.00	821228.07913	2155301.90112
Tangential Direction:	N 0°38'02.39" W		
Tangential Length:	1345.65		

Alignment Name: A004
Alignment Description: CL Southbound Lane
Alignment Style: Centerline

	Station	Northing	Easting
Element: Circular			
PC (307)	3047+04.35	819880.51349	2155316.79085
PI ()	3086+41.41	823817.32847	2155273.22682
CC ()	3107+53.71674	819753.71674	2143858.33638

PT (343)	3122+88.88	826896.07515	2152819.30579
Radius:	11459.16		
Delta:	37°55'21.61" Left		
Degree of Curvature (Aro):	0°30'00.00"		
Length:	7584.53		
Tangent:	3937.08		
Chord:	7448.85		
Middle Ordinate:	621.80		
External:	657.47		
Tangent Direction:	N 0°38'02.39" W		
Radial Direction:	N 89°21'57.81" E		
Chord Direction:	N 19°35'43.19" W		
Radial Direction:	N 51°28'38.00" E		
Tangent Direction:	N 38°33'24.00" W		

PLS	SMS	OKLAHOMA DEPARTMENT OF TRANSPORTATION SURVEY DIVISION
DRAWN	SMS	
CHECKED	SMS	
APPROVED	DEA	
CREW	TECUMSEH	
COUNTY	McCLAIN	
		SURVEY DATA SHEET SWO 5398(1)
HIGHWAY	I-35	
STATE JOB NO.	32802(04)	SHEET NO. S008

SECTION 2
T-6-N, R-2-W
SE/4

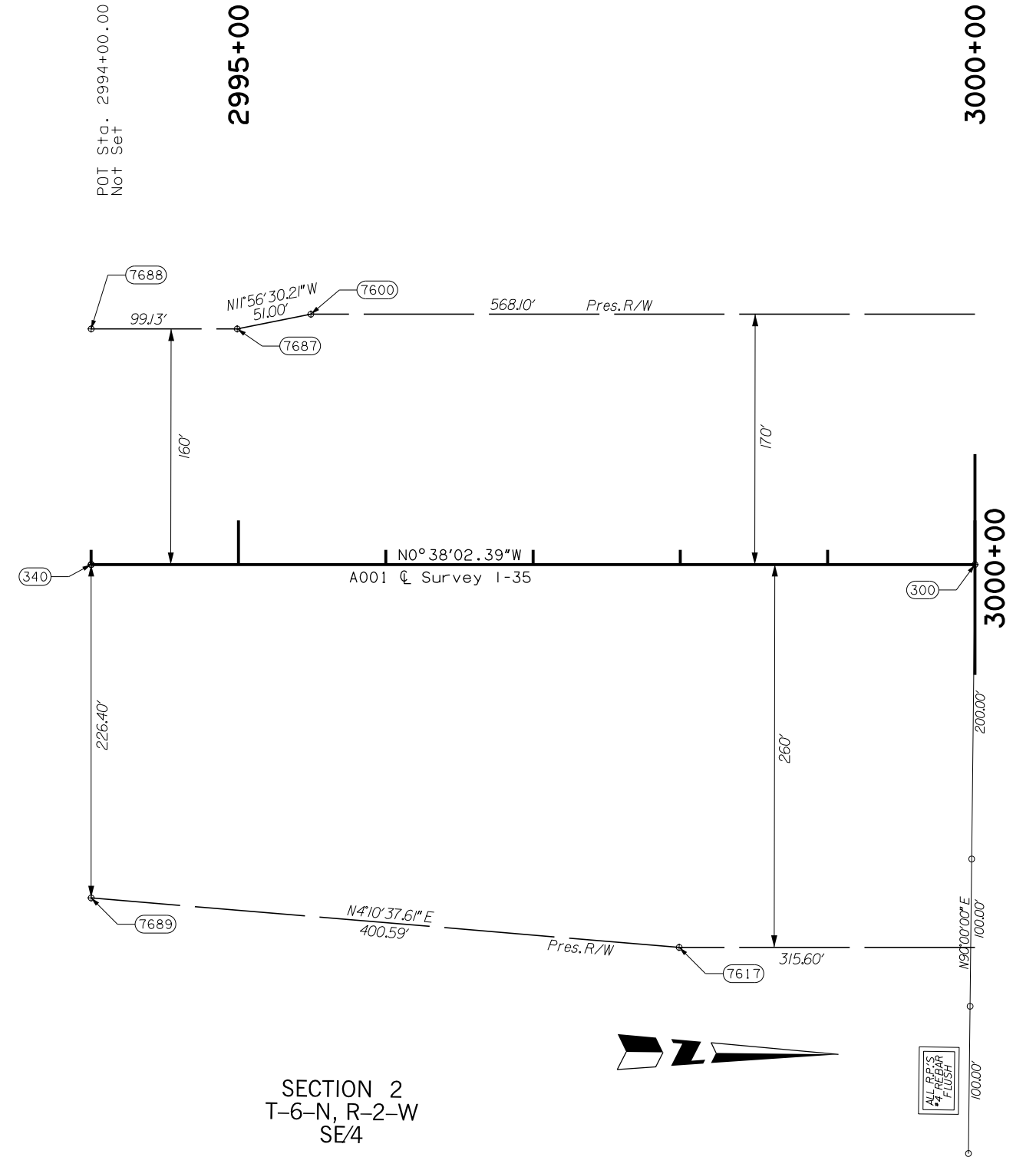

SECTION 2
T-6-N, R-2-W
SE/4



ALL REBAR
FLUSH

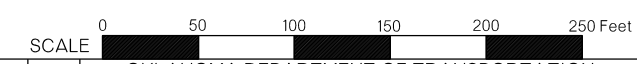

PLS	SMS	OKLAHOMA DEPARTMENT OF TRANSPORTATION SURVEY DIVISION SURVEY DATA SHEET SWO 5398(1)
DRAWN	SMS	
CHECKED	SMS	
APPROVED	DEA	
CREW	TECUMSEH	
COUNTY	McCLAIN	

SECTION 2
T-6-N, R-2-W
SE/4

3000+00

POB Sta. 3000+00.00
Begin SW05398(1) Survey
=Sta. 1428+00.00
SW02170(1) Survey
Set #4 Rebar

POT Sta. 3001+16.27
on EW 137.5 1/4 Sec. Line
1455.74'E to 1/4 Sec. Cor.
1189.04'W to Gen. Sec.
Set #4 Rebar

3005+00

3010+00

SECTION 2
T-6-N, R-2-W
NE/4

POT Sta. 3010+00.00
Set #4 Rebar

Westbrook Phase II

3014+00

3000+00

ALL REBAR
#4 REBAR
FLUSH

ALL REBAR
#4 REBAR
FLUSH

SECTION 2
T-6-N, R-2-W
SE/4

SECTION 2
T-6-N, R-2-W
NE/4

BEARING EQUATION:

N 0°38'02.39" W this survey =
S 0°24'57" E on F.A.P. No. 1-35-2(13)091 Plans =
S 0°24'57" E on S.W.O. 2170(1) Survey

STATION EQUATION:

Sta. 3000+00 this survey =
Sta. 1428+00 on F.A.P. No. 1-35-2(13)091 Plans =
Sta. 1428+00 on S.W.O. 2170(1) Survey.



SCALE 0 50 100 150 200 250 Feet

PLS	SMS	OKLAHOMA DEPARTMENT OF TRANSPORTATION SURVEY DIVISION
DRAWN	SMS	
CHECKED	SMS	
APPROVED	DEA	
CREW	TECUMSEH	
		SURVEY DATA SHEET
		SW05398(1)
COUNTY	McCLAIN	HIGHWAY 1-35 STATE JOB NO. 32802(04) SHEET NO. S010

SECTION 2
T-6-N, R-2-W
GOVT. LOT 2

SECTION 2
T-6-N, R-2-W
GOVT. LOT 2

SECTION 2
T-6-N, R-2-W
GOVT. LOT 1

SECTION 2
T-6-N, R-2-W
GOVT. LOT 1

SECTION 35
T-7-N, R-2-W
SE/4

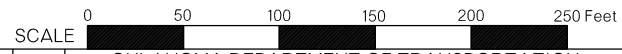
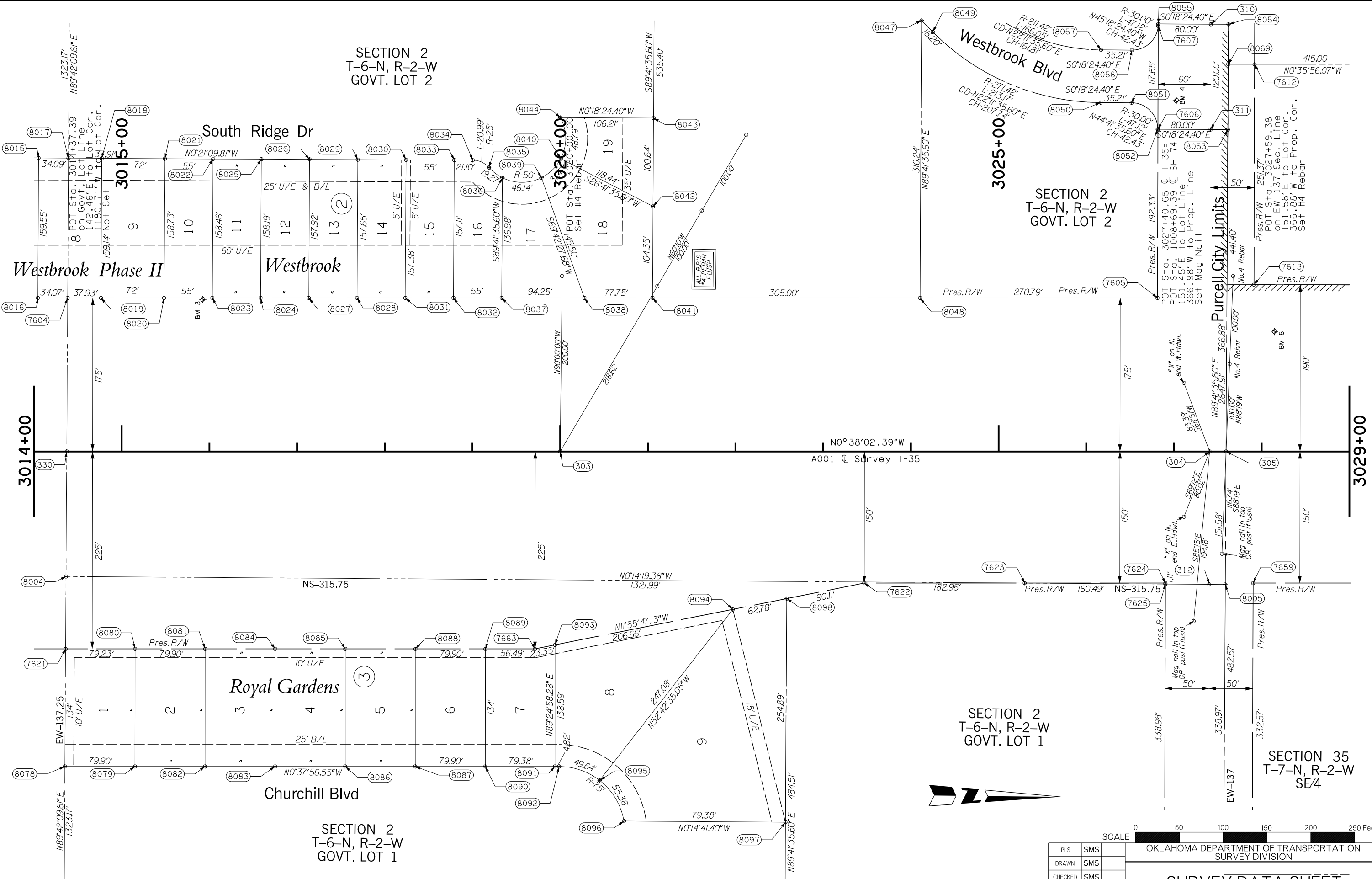

PLS	SMS	OKLAHOMA DEPARTMENT OF TRANSPORTATION SURVEY DIVISION
DRAWN	SMS	
CHECKED	SMS	
APPROVED	DEA	
CREW	TECUMSEH	
COUNTY	McCLAIN	

SURVEY DATA SHEET

SWO 5398(1)

SECTION 35
T-7-N, R-2-W
SE/4

SECTION 35
T-7-N, R-2-W
SE/4

SECTION 35
T-7-N, R-2-W
SE/4

SECTION 35
T-7-N, R-2-W
SE/4

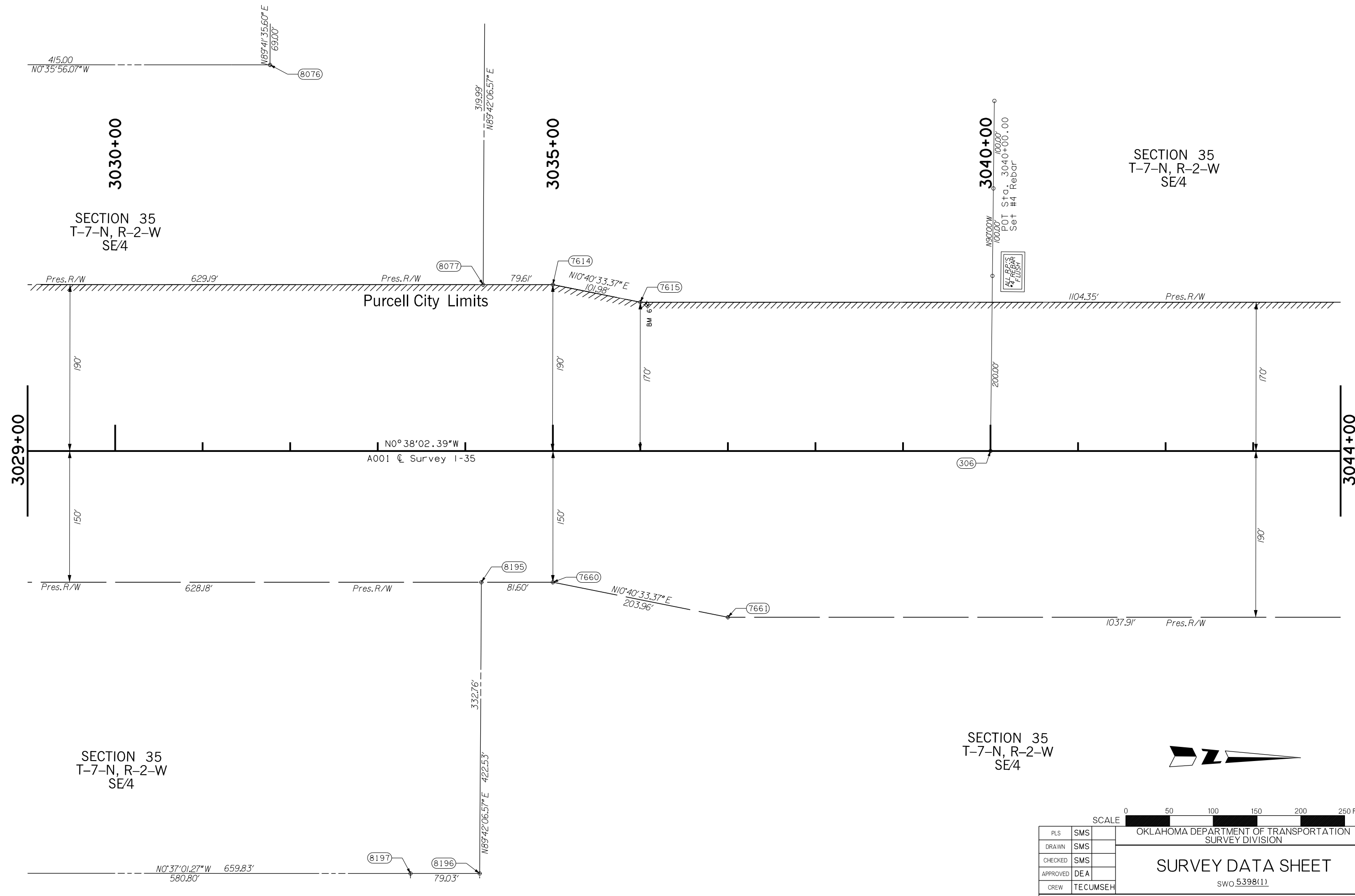

ALL REBAR
#4 REBAR
FLUSH



SCALE 0 50 100 150 200 250 Feet

PLS	SMS	OKLAHOMA DEPARTMENT OF TRANSPORTATION SURVEY DIVISION
DRAWN	SMS	
CHECKED	SMS	
APPROVED	DEA	
CREW	TECUMSEH	
COUNTY		McCLAIN
HIGHWAY		I-35
STATE JOB NO.		32802(04)
SHEET NO.		S012

SURVEY DATA SHEET

SWO 5398(1)

3045+00

SECTION 35
T-7-N, R-2-W
SE/4

3050+00
3050+00

3055+00
3055+00

CURVE DATA - C3
P.I. Sta. 3086+41.41
X=2155273.2269
Y=623817.3285
Δ=37°55'21.6" Lt.
D=0°30'00"
T=3937.06'
L=7584.53'
R=11459.16'
E=657.47'

PT Sta. 3047+04.35
End SW05398(1) Survey
=Sta. 1380+92.72
SW02170(1) Survey
Set #4 Rebar

POT Sta. 3053+99.54
(Southbound Lane)
On EW 136.5 1/4 Sec. Line
1496.57' East to 1/4 Sec. Cor.
1149.13' West to Cen. Sec.
Not Set

POT Sta. 3053+98.98
(Northbound Lane)
On EW 136.5 1/4 Sec. Line
1475.49' East to 1/4 Sec. Cor.
1170.21' West to Cen. Sec.
Not Set

R-11289.16'
L-681.32'
CD-N2°21'46.64"W
CH-681.22'

R-11309.16'
L-98.69'
CD-N4°50'30.86"W
CH-98.69'

R-11289.16'
L-351.39'
CD-N6°29'00.96"W
CH-351.38'

3044+00

A001 C Survey 1-35
N0°38'02.39"W

A003 C Survey 1-35
Northbound Lane
N0°38'02.39"W

3058+00
3058+00

1037.91' Pres.R/W

158.84'

301.68

651.97' Pres.R/W

BEARING EQUATION:

N 0°38'02.39" W this survey =
S 0°24'57" E on F.A.P. No. 1-35-2(13)091 Plans =
S 0°24'57" E on S.W.O. 2170(1) Survey

STATION EQUATION:

Sta. 3047+04.35 this survey =
Sta. 1380+92.72 on F.A.P. No. 1-35-2(13)091 Plans =
Sta. 1380+92.72 on S.W.O. 2170(1) Survey.

SECTION 35
T-7-N, R-2-W
SE/4



SCALE 0 50 100 150 200 250 Feet

PLS	SMS	
DRAWN	SMS	
CHECKED	SMS	
APPROVED	DEA	
CREW	TECUMSEH	

OKLAHOMA DEPARTMENT OF TRANSPORTATION
SURVEY DIVISION

SURVEY DATA SHEET
SWO 5398(1)

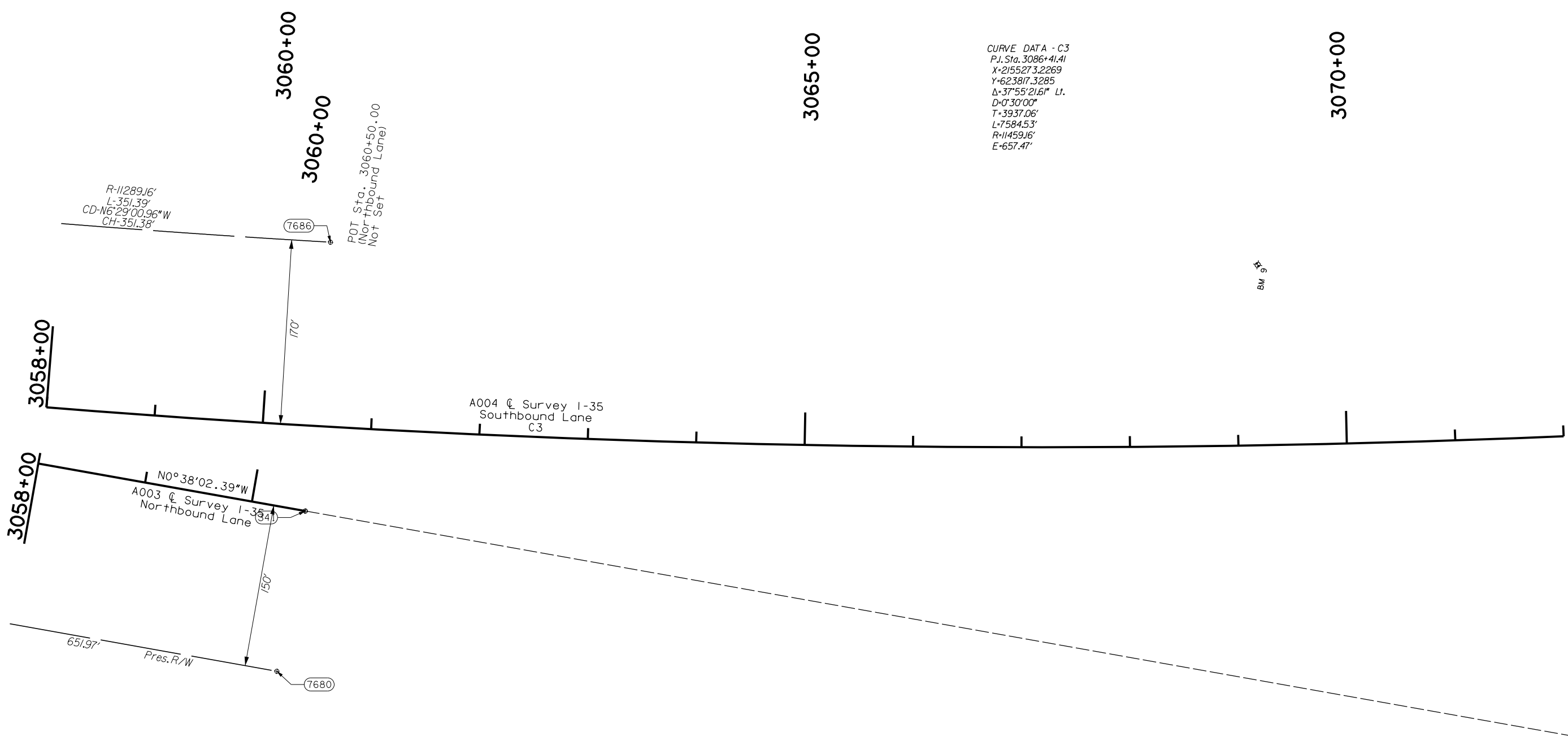

CURVE DATA - C3
 P.I. Sta. 3086+41.41
 X=2155273.2269
 Y=623817.3285
 Δ=37°55'21.61" Lt.
 D=0°30'00"
 T=3937.06'
 L=7584.53'
 R=11459.16'
 E=657.47'

R=11289.16'
 L=351.39'
 CD=N6°29'00.96"W
 CH=351.38'

POT Sta. 3060+50.00
 (Northbound Lane)
 Not Set

A004 C Survey I-35
 Southbound Lane
 C3

N0°38'02.39"W
 A003 C Survey I-35
 Northbound Lane

Pres. R/W

BM 9



SCALE 0 50 100 150 200 250 Feet

PLS	SMS
DRAWN	SMS
CHECKED	SMS
APPROVED	DEA
CREW	TECUMSEH

OKLAHOMA DEPARTMENT OF TRANSPORTATION
 SURVEY DIVISION

SURVEY DATA SHEET

SWO 5398(1)

SECTION 35
T-7-N, R-2-W
SW/4

SECTION 35
T-7-N, R-2-W
SW/4

SECTION 35
T-7-N, R-2-W
SW/4

Purcell City Limits

Purcell City Limits

980+00

985+00

985+00

CURVE DATA - C1
Pc: 510.974+18.94
X: 215285.9753
Y: 69245.714
Δ: 150°18.78' Rt.
D: 200.16'
L: 231.44'
E: 199.99'
R: 197.04'
F: 16.50'

PT Sta. 980+67.49
Set Mag Nail over
Found #3 Rebar

05°29'11"DN
91°51'29"R
105.72

R-1957.04'
L-178.89'
CD-S50°18'22.28"E
CH-178.83'

R-1957.04'
L-334.21'
CD-S42°47'42.89"E
CH-333.80'

R-1857.04'
L-264.79'
CD-S48°50'24.57"E
CH-264.56'

R-1857.04'
L-222.10'
CD-S41°19'45.18"E
CH-221.96'

S52°55'29.64"E
546.40'

288.40'
N0°48'11.25"W

584.00'
N45°00'13.87"W

220.00'
N89°00'3.87"W

N0°31'45.40"W

1260.88'
1059.28'

7673

331

7672

8213

8212

8215

8214

8209

8210

8211

7675

7674

7671

332

333

SCALE 0 50 100 150 200 250 Feet

PLS	SMS
DRAWN	SMS
CHECKED	SMS
APPROVED	DEA
CREW	TECUMSEH

OKLAHOMA DEPARTMENT OF TRANSPORTATION
SURVEY DIVISION

SURVEY DATA SHEET

SWO 5398(1)

SECTION 35
T-7-N, R-2-W
SW/4

SECTION 35
T-7-N, R-2-W
SE/4

SECTION 35
T-7-N, R-2-W
SW/4

SECTION 35
T-7-N, R-2-W
SW/4

SECTION 2
T-6-N, R-2-W
GOVT. LOT 3

SECTION 2
T-6-N, R-2-W
GOVT. LOT 2

985+00

990+00

995+00

1000+00

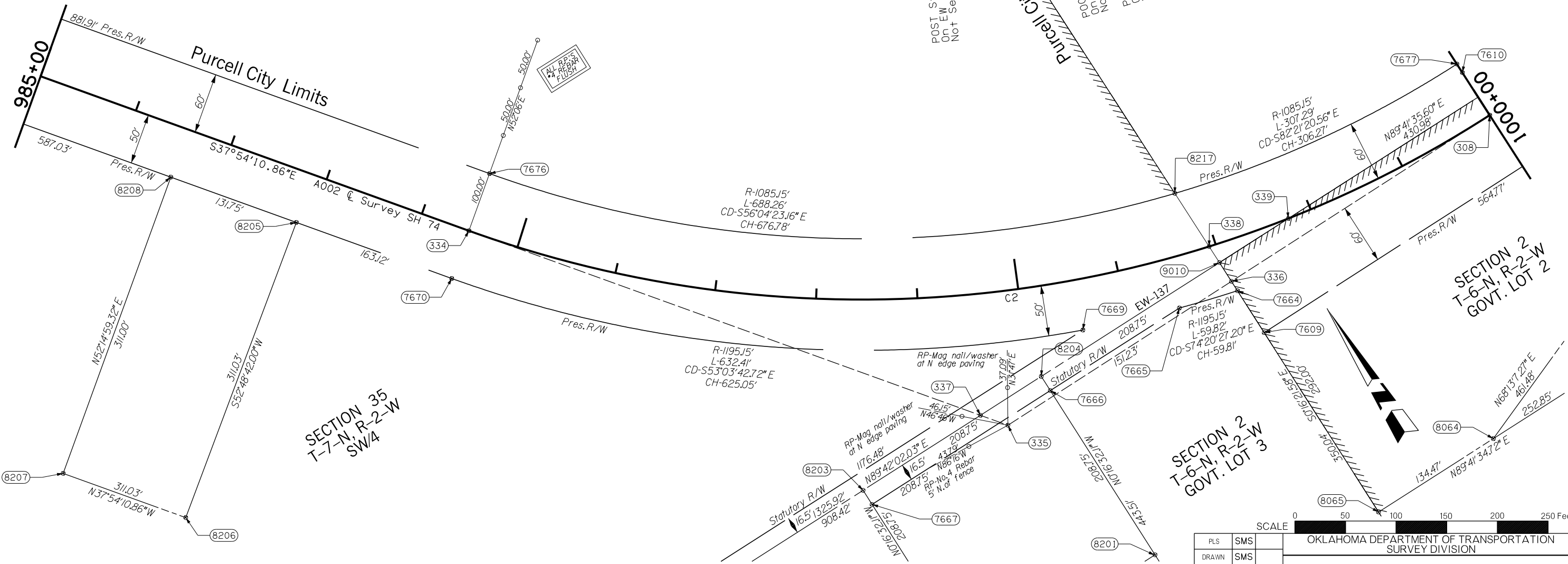

CURVE DATA - C2
 P.I. Sta. 995+14.93
 X=215.3903, Y=617.9052, Z=0.68
 Δ=52°33'54.87" U.
 D=5'00'12"
 T=565.54'
 L=1050.60'
 R=1145.15'
 E=132.03'

PC Sta. 989+49.40
 Set Mag Nail

POST Sta. 994+86.15
 On EW 137 Sec. Line
 Not Set

POC Sta. 997+19.47
 Line
 Not Set
 POC Sta. 997+19.47
 Line
 Not Set
 POC Sta. 997+19.47
 Line
 Not Set

PT Sta. 1000+00.00
 Sub P.I. 1000+00.00
 Sub L. 1000+00.00
 Sub Δ=52°33'54.87" U.
 Sub T=565.54'
 Sub L=1050.60'
 Sub R=1145.15'
 Sub E=132.03'

SCALE 0 50 100 150 200 250 Feet

PLS	SMS	
DRAWN	SMS	
CHECKED	SMS	
APPROVED	DEA	
CREW	TECUMSEH	

OKLAHOMA DEPARTMENT OF TRANSPORTATION
 SURVEY DIVISION

SURVEY DATA SHEET
 SWO 5398(1)

COUNTY McCLAIN HIGHWAY I-35 STATE JOB NO. 32802(04) SHEET NO S016

PC Sta. 1000+00.00
 Begin SW5398(1) Survey
 =Sta. 100+98.5
 SAP No. 1013(1) Plans
 Set Mag Nail

1000+00

BEARING EQUATION:
 N 89°31'54.34" E this survey =
 S 89°29' W on S.A.P. No. 1013(1) Plans

STATION EQUATION:
 Sta. 1000+00 this survey =
 Sta. 100+98.5 on S.A.P. No. 1013(1) Plans

SECTION 35
 T-7-N, R-2-W
 SE/4

1005+00
 3030+00

SECTION 35
 T-7-N, R-2-W
 SE/4

1010+00

SECTION 35
 T-7-N, R-2-W
 SE/4

SECTION 35
 T-7-N, R-2-W
 SE/4

1014+00

SECTION 2
 T-6-N, R-2-W
 GOVT. LOT 1

SECTION 2
 T-6-N, R-2-W
 GOVT. LOT 2

SECTION 2
 T-6-N, R-2-W
 GOVT. LOT 2

3025+00

Westbrook Blvd

Purcell City Limits



SCALE 0 50 100 150 200 250 Feet

PLS	SMS	
DRAWN	SMS	
CHECKED	SMS	
APPROVED	DEA	
CREW	TECUMSEH	
OKLAHOMA DEPARTMENT OF TRANSPORTATION SURVEY DIVISION		
SURVEY DATA SHEET		
SWO 5398(1)		
COUNTY	McCLAIN	HIGHWAY I-35 STATE JOB NO. 32802(04) SHEET NO. S017

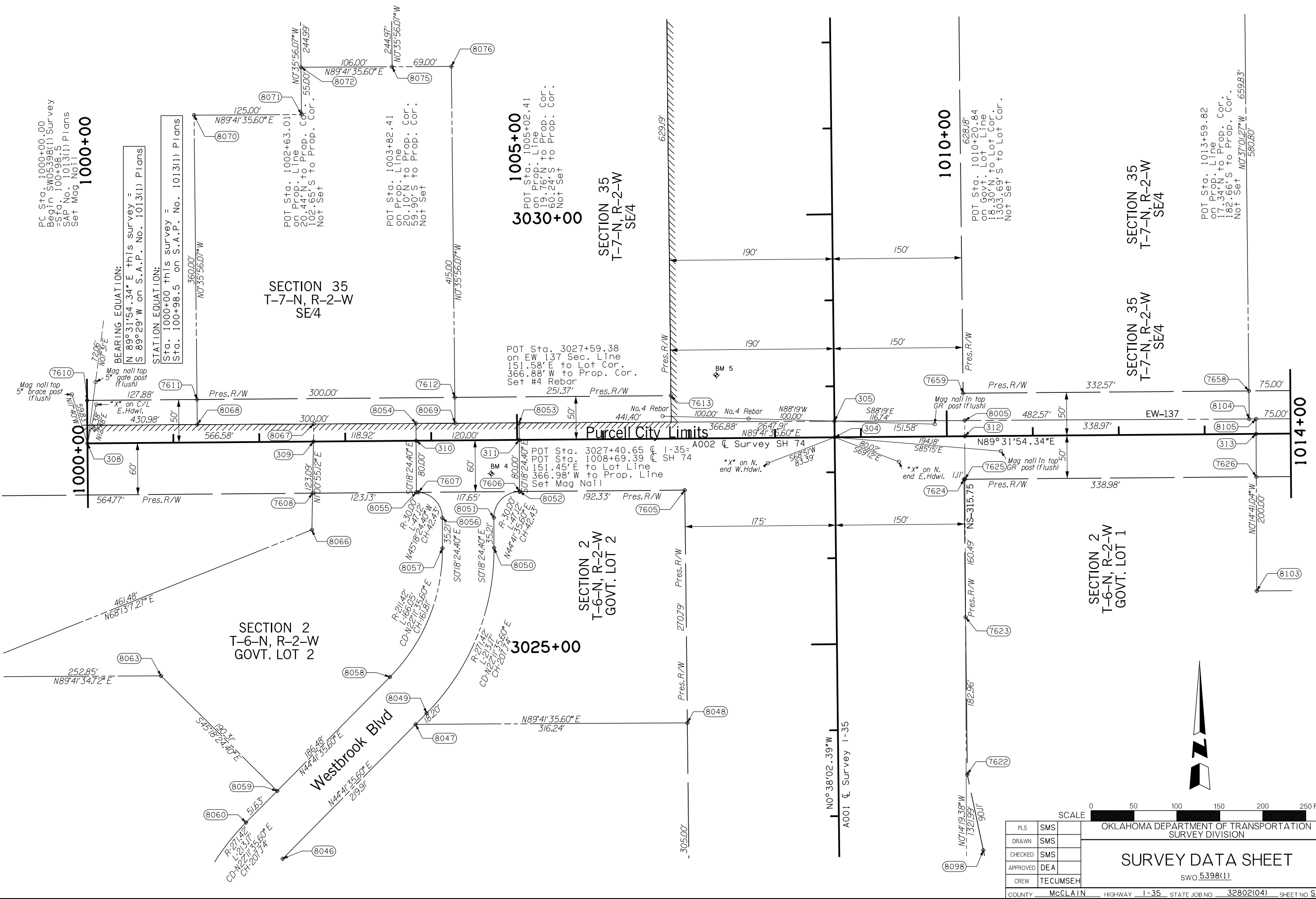

SECTION 35
T-7-N, R-2-W
SE/4

SECTION 36
T-7-N, R-2-W
SW/4

Lugena Lane

Christian No. 1 Addition

Weeks Addition

Weeks Addition

SECTION 1
T-6-N, R-2-W
GOVT. LOT 4

SECTION 2
T-6-N, R-2-W
GOVT. LOT 1



SCALE 0 50 100 150 200 250 Feet

PLS	SMS	OKLAHOMA DEPARTMENT OF TRANSPORTATION SURVEY DIVISION
DRAWN	SMS	
CHECKED	SMS	
APPROVED	DEA	
CREW	TECUMSEH	
SURVEY DATA SHEET		SWO 5398(1)
COUNTY <u>McCLAIN</u> HIGHWAY <u>I-35</u> STATE JOB NO. <u>32802(04)</u> SHEET NO <u>S018</u>		

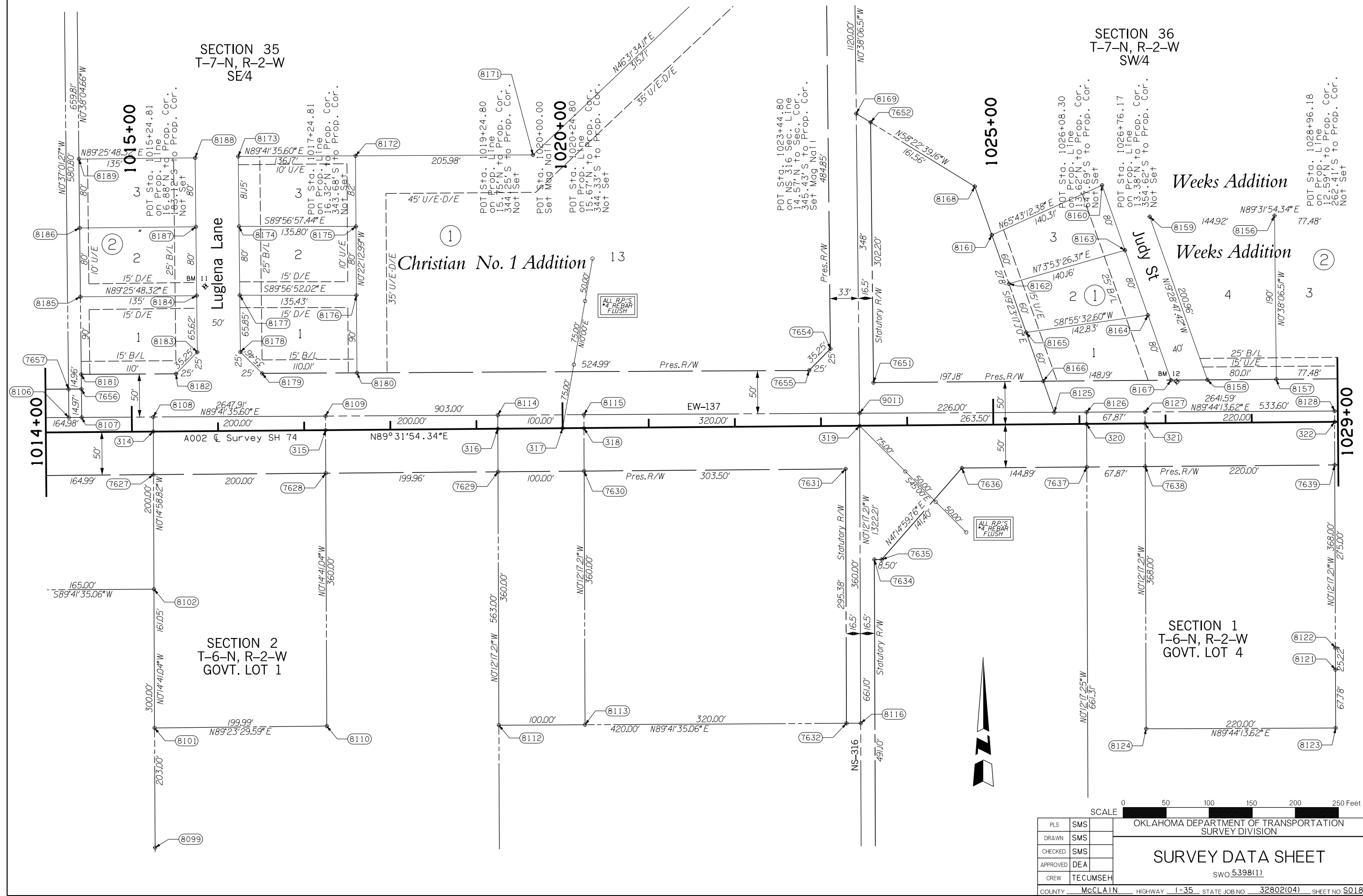

SECTION 36
T-7-N, R-2-W
SW/4

POT Sta. 1030+00.00
Set Mag Nail
1030+00

Weeks Addition

Garland Drive

American Subdivision

POT Sta. 1034+99.81
on Prop. Line
10.43' N to Prop. Cor.
59.57' S to Prop. Cor.
Not Set
1035+00

POT Sta. 1038+11.97
End SW05398(1) Survey
=Sta. 62+86.59
SAP No. 1013(1) Plans
=Sta. 5+083.709 (Metric)
SW02036(3)
Set Mag Nail

BEARING EQUATION:
N 89°31'54.34" E this survey =
S 89°29' W on S.A.P. No. 1013(1) Plans =
N 89°46'18.46" E on S.W.O. 2036(3) Survey

STATION EQUATION:
Sta. 1038+11.97 this survey =
Sta. 62+86.59 on S.A.P. No. 1013(1) Plans =
Sta. 5+083.709 (Metric) on S.W.O. 2036(3) Survey.

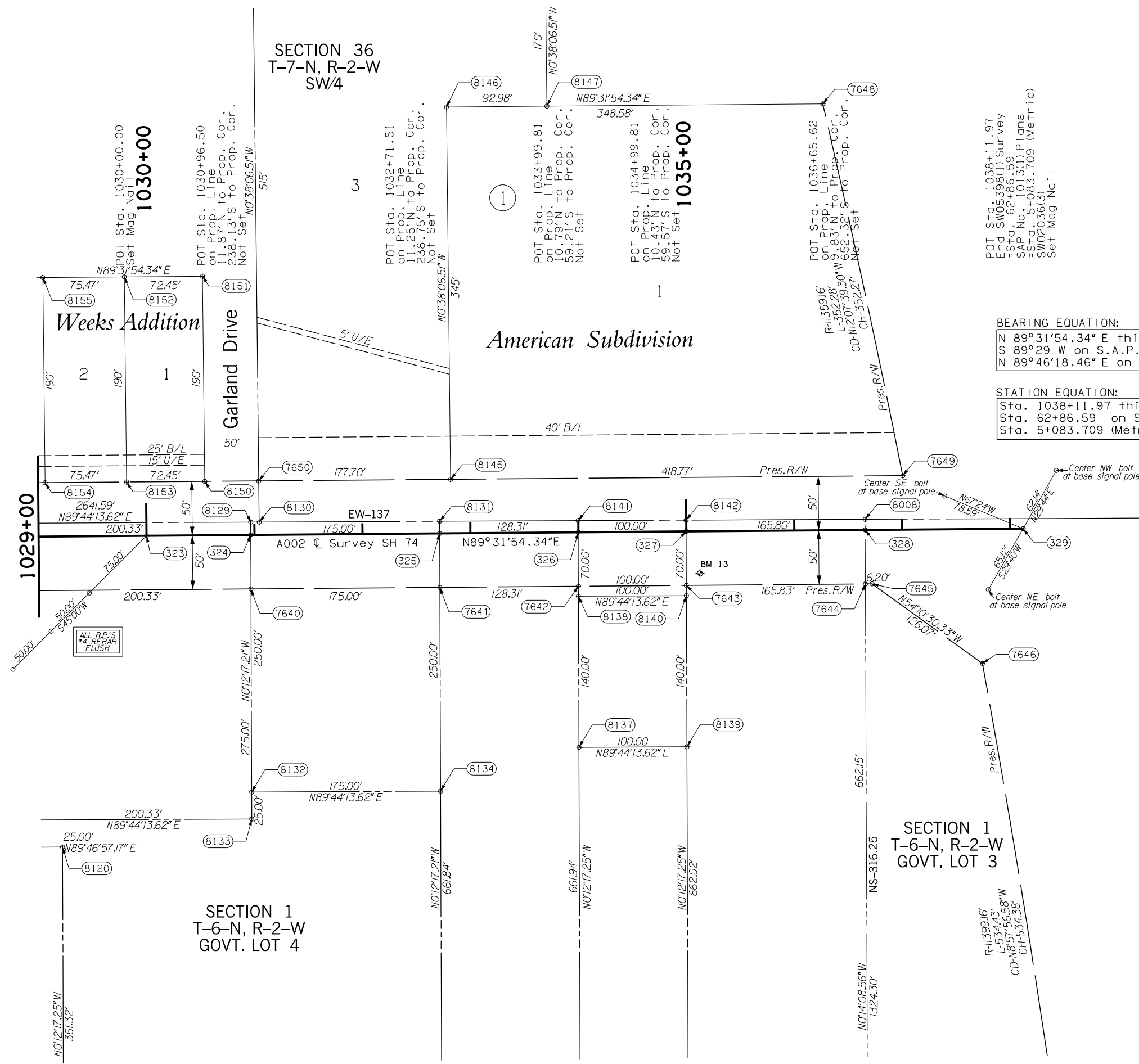

SCALE 0 50 100 150 200 250 Feet

PLS	SMS	
DRAWN	SMS	
CHECKED	SMS	
APPROVED	DEA	
CREW	TECUMSEH	

OKLAHOMA DEPARTMENT OF TRANSPORTATION
SURVEY DIVISION

SURVEY DATA SHEET
SW05398(1)

Section Corner – ODOT Monument No. M-44-854
 Found and accepted 1" steel pipe as shown on
 corner record filed by David L.M. Louy, PLS 1310.

1/4 Section Corner – ODOT Monument No. M-44-855
 Found and accepted #4 rebar as shown on corner
 record filed by Shaun Christopher Axton, PLS 1494.

Section Corner – ODOT Monument No. M-44-856
 Found and accepted #3 rebar as shown on corner
 record filed by Bobby L. Curtis, PLS 603, Garren
 Dodson, PLS 696 and T. Wayne Fisch, PLS 1378.

1/4 Section Corner – ODOT Monument No. M-44-857
 Found and accepted #3 rebar as shown on corner
 record filed by T. Wayne Fisch, PLS 1378.

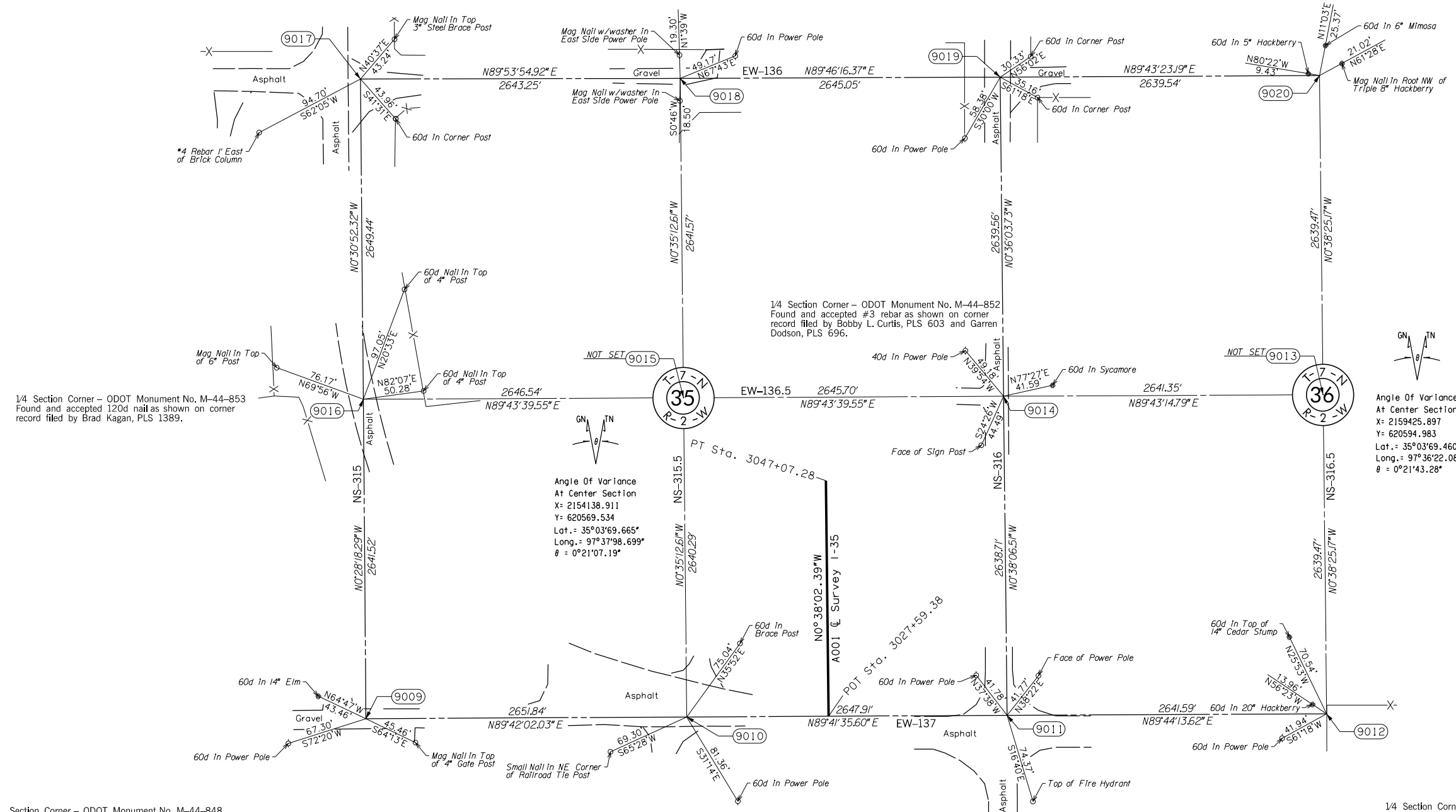

1/4 Section Corner – ODOT Monument No. M-44-853
 Found and accepted 120d nail as shown on corner
 record filed by Brad Kagan, PLS 1389.

1/4 Section Corner – ODOT Monument No. M-44-852
 Found and accepted #3 rebar as shown on corner
 record filed by Bobby L. Curtis, PLS 603 and Garren
 Dodson, PLS 696.

Angle Of Variance
 At Center Section
 X = 2154138.911
 Y = 620569.534
 Lat. = 35°03'69.665"
 Long. = 97°37'98.699"
 θ = 0°21'07.19"

Angle Of Variance
 At Center Section
 X = 2159425.897
 Y = 620594.983
 Lat. = 35°03'69.460"
 Long. = 97°36'22.085"
 θ = 0°21'43.28"

Section Corner – ODOT Monument No. M-44-848
 Found and accepted #3 rebar as shown on corner
 record filed by Brad Kagan, PLS 1389, Shaun
 Christopher Axton, PLS 1494 and Darrel Ray
 Mason, PLS 1690. Also found #3 rebar 0.2' north
 and 1.3' east of corner.

1/4 Section Corner – ODOT Monument No. M-44-849
 Found and accepted 80d nail. This monument
 appears to match the location shown on corner
 record filed by Melfred Roy Loyall, Jr., PLS 1317,
 Shaun Christopher Axton, PLS 1494 and Darrel Ray
 Mason, PLS 1690. Also found mag nail 1.9' north and
 0.8' west of corner as shown on corner record filed by
 Randall A. Mansfield, PLS 1613.

Section Corner – ODOT Monument No. M-44-850
 Found and accepted 3/4" pipe. This monument
 matches the location shown on corner record filed
 by Farriel G. Thomas, PLS 491 and Garren Dodson,
 PLS 696. Also found #3 rebar 1.0' north and 4.5'
 west of corner.

1/4 Section Corner – ODOT Monument No. M-44-851
 Found and accepted #3 rebar as shown on corner
 record filed by Bobby L. Curtis, PLS 603 and Steve
 Roland Schuelein, PLS 1256. Also found #4 rebar
 with cap 6.6' north and 2.8' west of corner as shown
 on corner record filed by T. Wayne Fisch, PLS 1378.
 Also found #3 rebar with cap PLS 1564 3.2' west
 of corner.

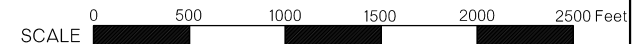

PLS	SMS	
DRAWN	SMS	
CHECKED	SMS	
APPROVED	DEA	
CREW	TECUMSEH	
OKLAHOMA DEPARTMENT OF TRANSPORTATION SURVEY DIVISION		
SURVEY DATA SHEET		
SWO 5398(1)		
COUNTY	McCLAIN	HIGHWAY I-35 STATE JOB NO. 32802(04) SHEET NO. S020

NOTE: REFERENCE'S SHOWN ARE NOT TO SCALE.

Section Corner – ODOT Monument No. M-44-848
 Found and accepted #3 rebar as shown on corner record filed by Brad Kagan, PLS 1389, Shaun Christopher Axton, PLS 1494 and Darrel Ray Mason, PLS 1690. Also found #3 rebar 0.2' north and 1.3' east of corner.

1/4 Section Corner – ODOT Monument No. M-44-849
 Found and accepted 80d nail. This monument appears to match the location shown on corner record filed by Melfred Roy Loyall, Jr., PLS 1317, Shaun Christopher Axton, PLS 1494 and Darrel Ray Mason, PLS 1690. Also found mag nail 1.9' north and 0.8' west of corner as shown on corner record filed by Randall A. Mansfield, PLS 1613.

Section Corner – ODOT Monument No. M-44-850
 Found and accepted 3/4" pipe. This monument matches the location shown on corner record filed by Farrel G. Thomas, PLS 491 and Garren Dodson, PLS 696. Also found #3 rebar 1.0' north and 4.5' west of corner.

1/4 Section Corner – ODOT Monument No. M-44-851
 Found and accepted #3 rebar as shown on corner record filed by Bobby L. Curtis, PLS 603 and Steve Roland Schuelein, PLS 1256. Also found #4 rebar with cap 6.6' north and 2.8' west of corner as shown on corner record filed by T. Wayne Fisch, PLS 1378. Also found #3 rebar with cap PLS 1564 3.2' west of corner.

1/4 Section Corner – ODOT Monument No. M-44-847
 Found and accepted #4 rebar as shown on corner record filed by Floyd Drannon, PLS 1503. Also found 2" steel pipe 5.3' north and 1.6' east of corner as shown on corner record filed by Darrel Ray Mason, PLS 1690.

Angle of Variance
 At Center Section
 X = 2154178.531
 Y = 615286.366
 Lat. = 35°02'24.506"
 Long. = 97°37'98.460"
 θ = 0°21'07.24"

Angle of Variance
 At Center Section
 X = 2159467.735
 Y = 615302.915
 Lat. = 35°02'24.055"
 Long. = 97°36'21.805"
 θ = 0°21'43.33"

Section Corner – ODOT Monument No. M-44-610
 Found and accepted #4 rebar as shown on corner record filed by Derrick E. Anderson, PLS 1551. Also found aluminum cap 13.8' west of corner as shown on corner record filed by Bill J. Casey, PLS 1122.

1/4 Section Corner – ODOT Monument No. M-44-612
 Found and accepted #3 rebar as shown on corner record filed by Timothy G. Pollard, PLS 1474, Derrick E. Anderson, PLS 1551 and Darrel Ray Mason, PLS 1690.

Section Corner – ODOT Monument No. M-44-613R
 Found and accepted #3 rebar as shown on corner record filed by Timothy G. Pollard, PLS 1474, T. Wayne Fisch, PLS 1378, Derrick E. Anderson, PLS 1551 and R. Wesley Bennett, PLS 1562. Also found #3 rebar 31.4' east of corner.

1/4 Section Corner – ODOT Monument No. M-44-732
 Set #4 rebar with cap at the location shown on corner record filed by R. Wesley Bennett, PLS 1562. Also found #4 rebar set for witness corner and filed by T. Wayne Fisch, PLS 1378.

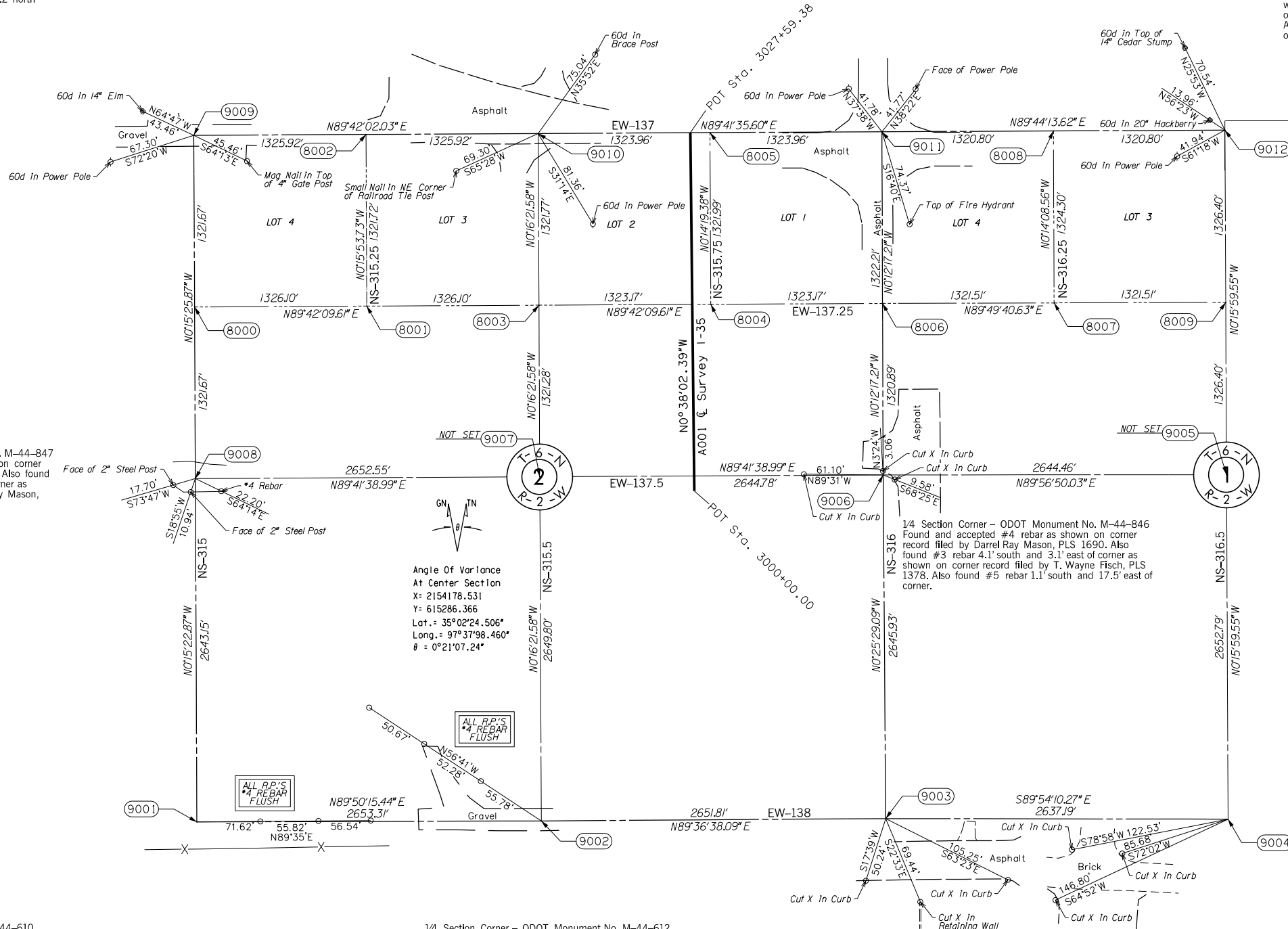

ALL R.P.'S
 #4 REBAR
 FLUSH

ALL R.P.'S
 #4 REBAR
 FLUSH

NOTE: REFERENCE'S SHOWN ARE NOT TO SCALE.

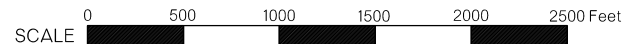

PLS	SMS	
DRAWN	SMS	
CHECKED	SMS	
APPROVED	DEA	
CREW	TECUMSEH	
COUNTY	McCLAIN	HIGHWAY I-35 STATE JOB NO. 32802(04) SHEET NO. S021

SURVEY DATA SHEET

SWO 5398(1)



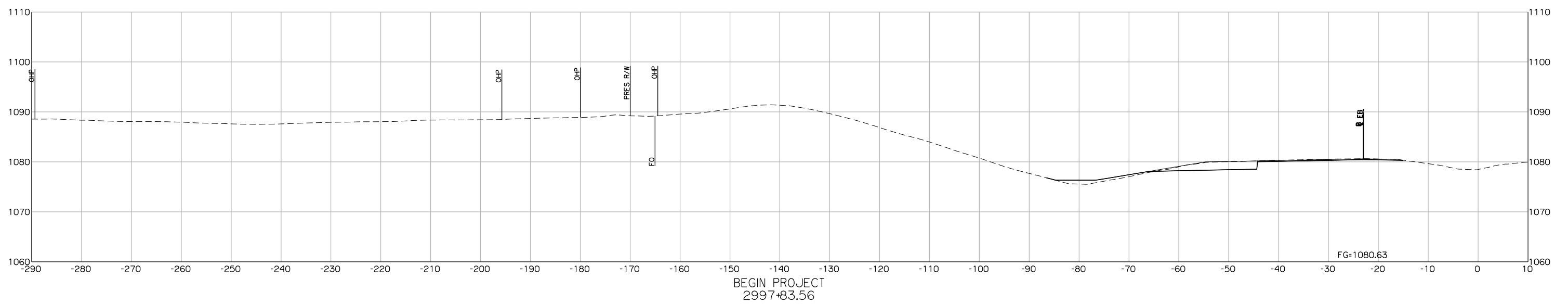
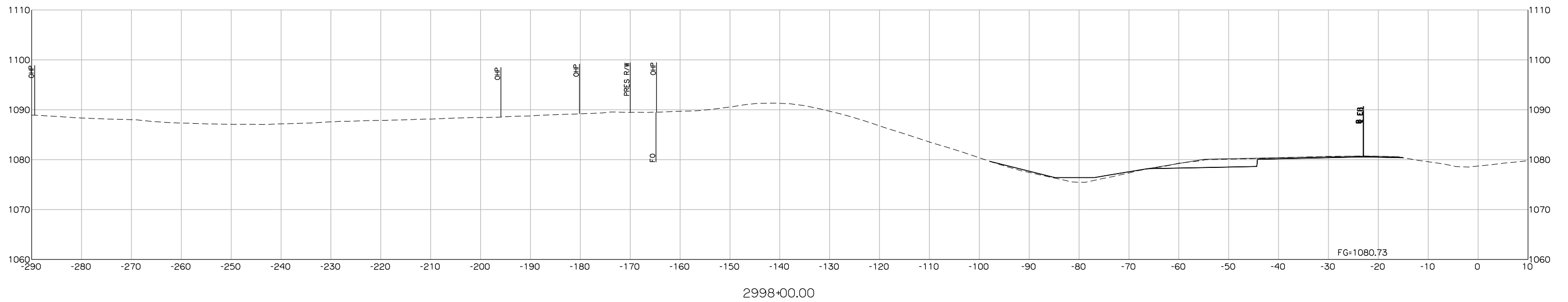

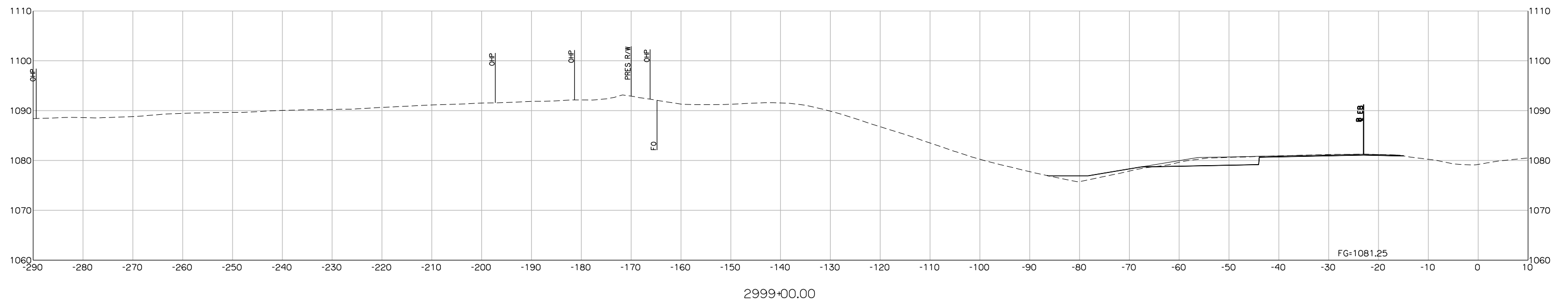
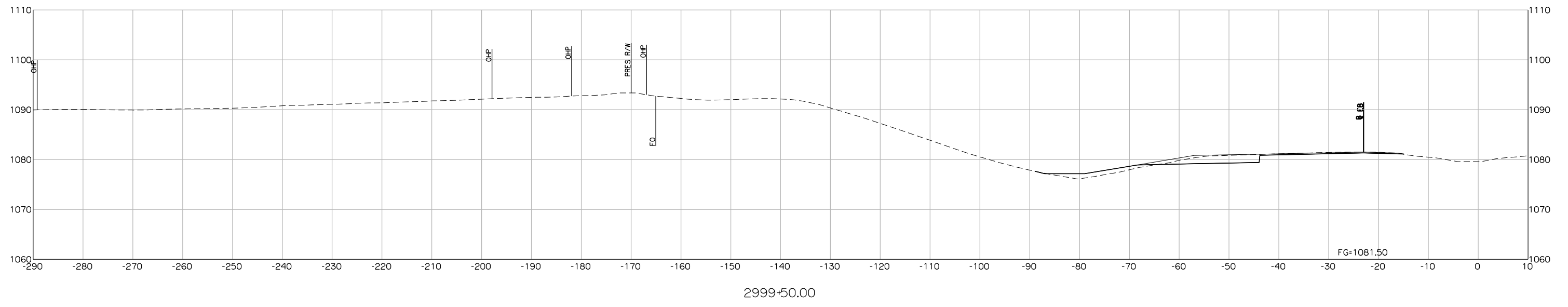

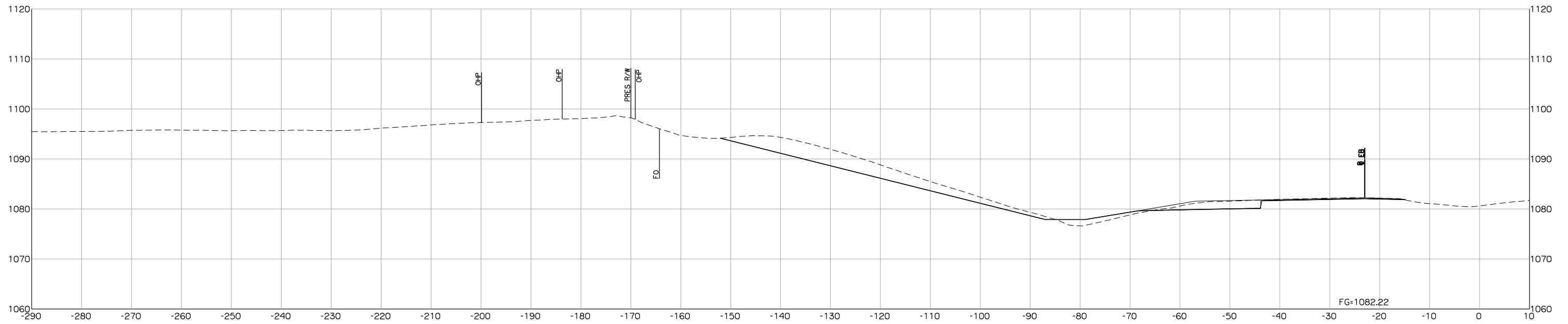

3001+00.00

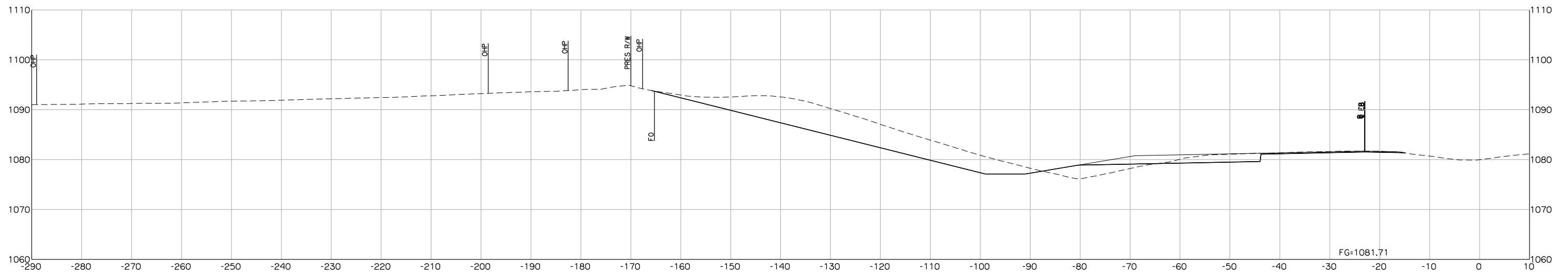

3000+00.00

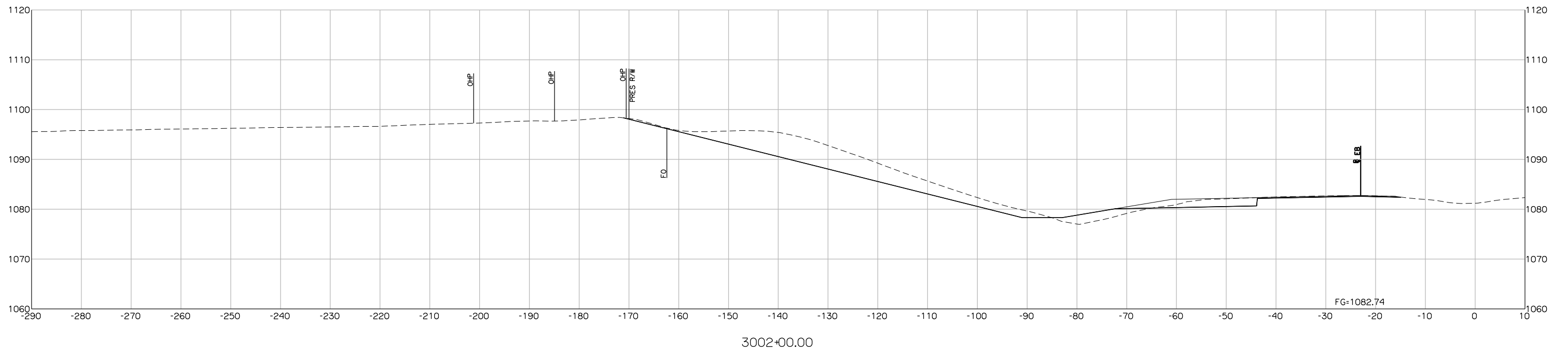
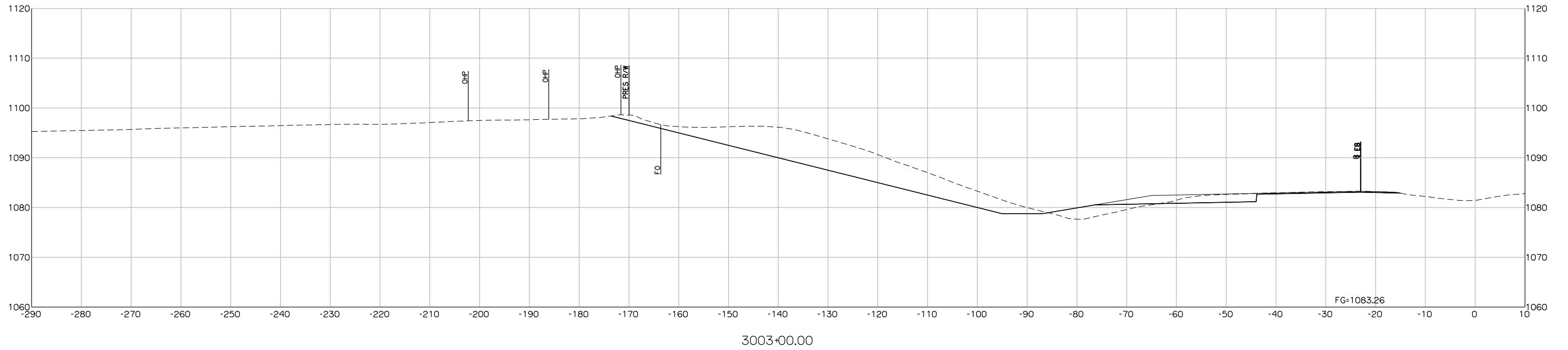

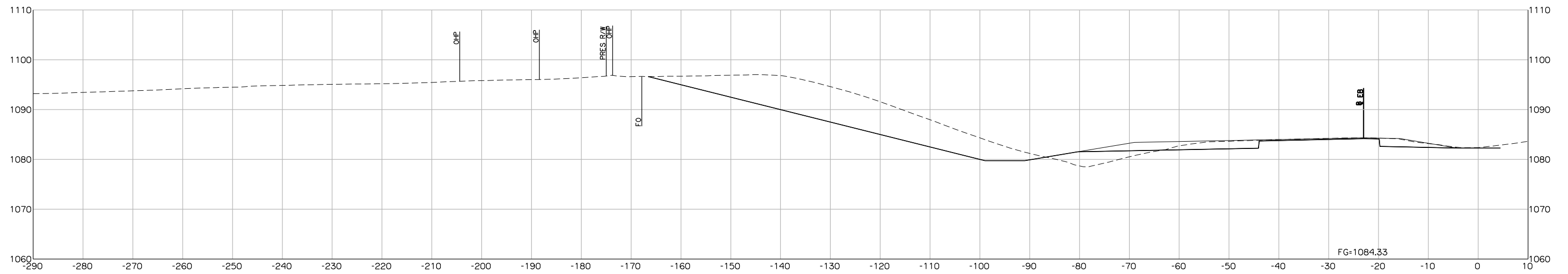

3005+00.00

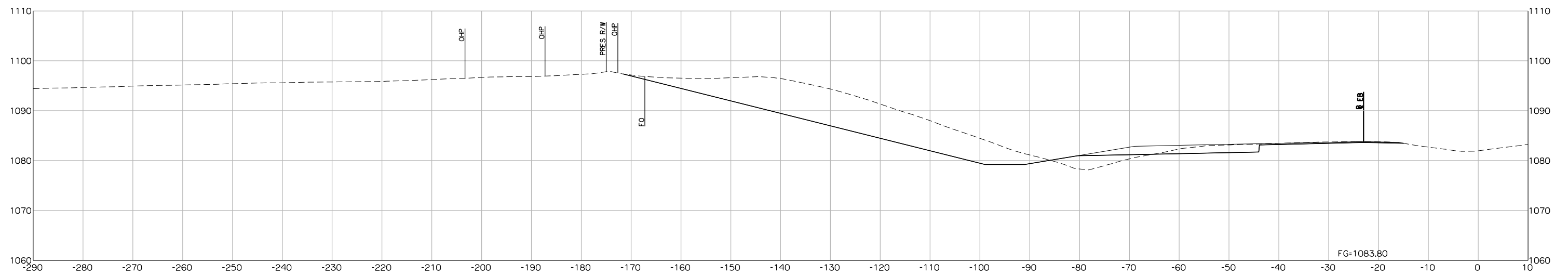

3004+00.00

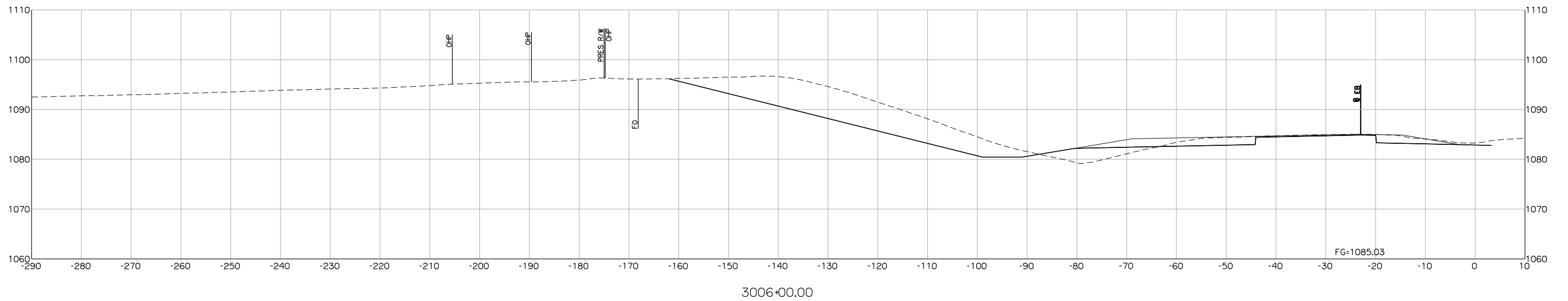
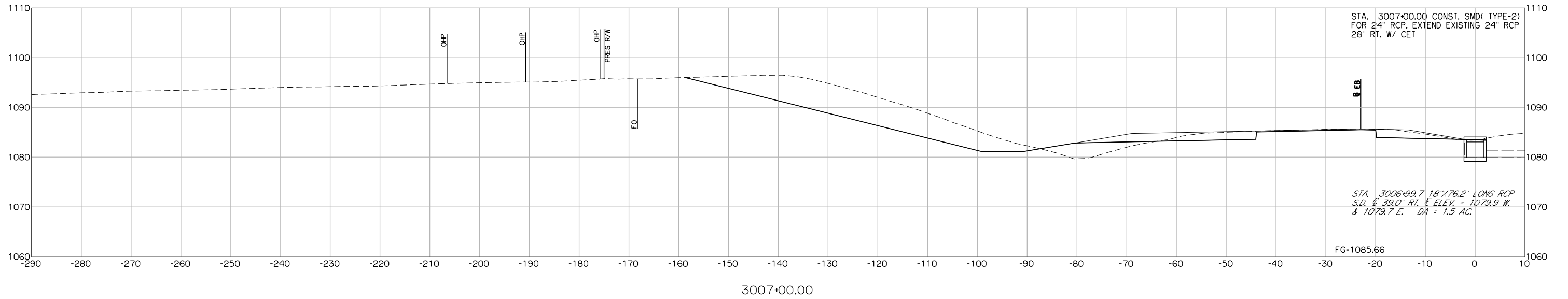

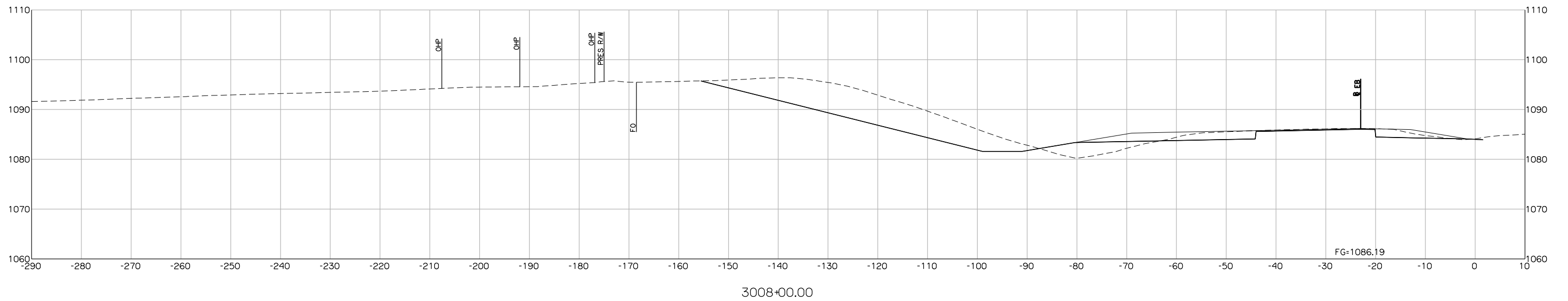
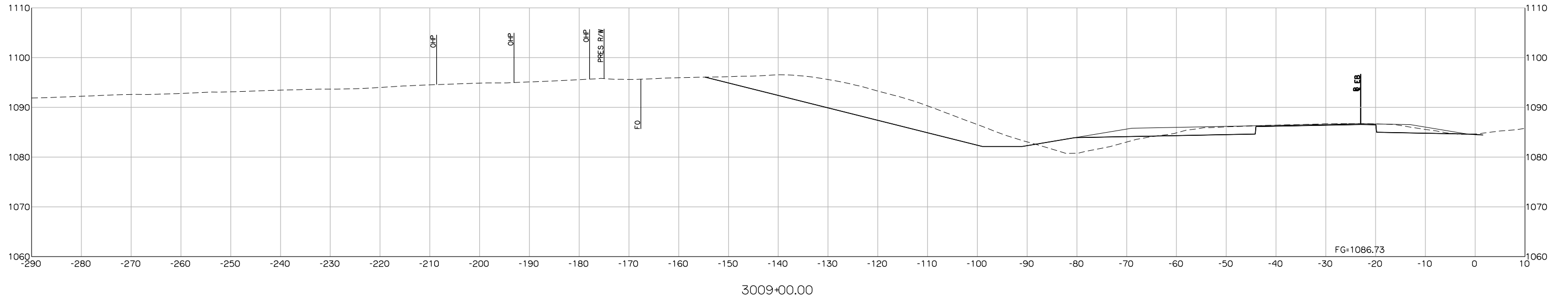

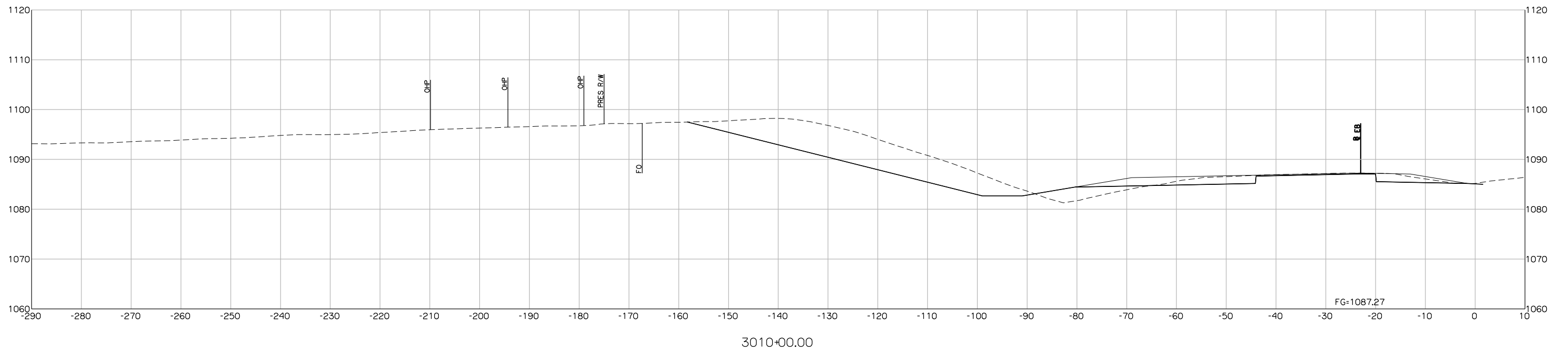
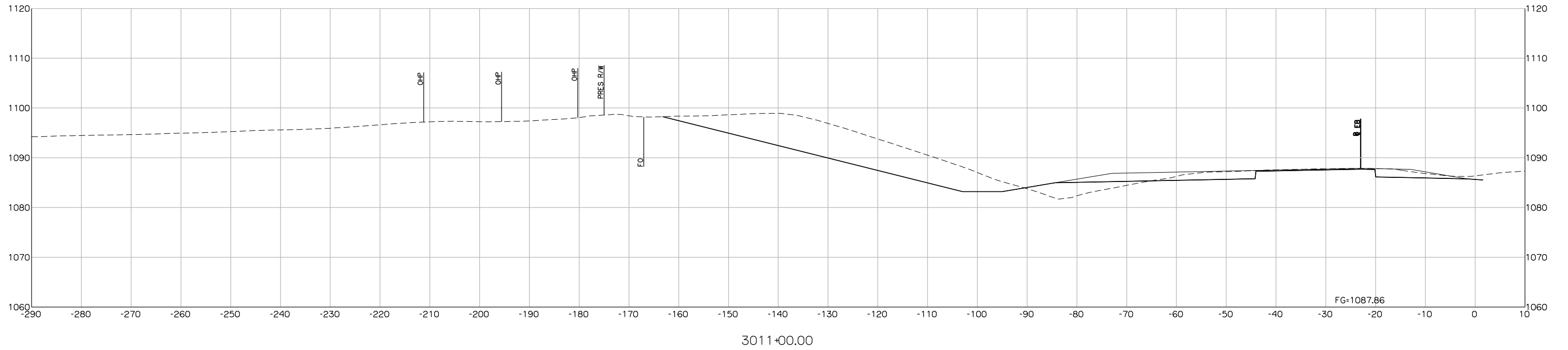

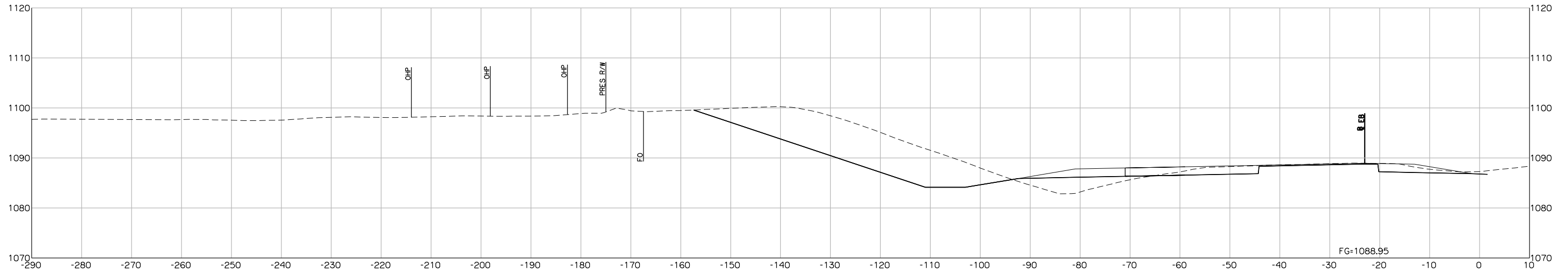

3013+00.00

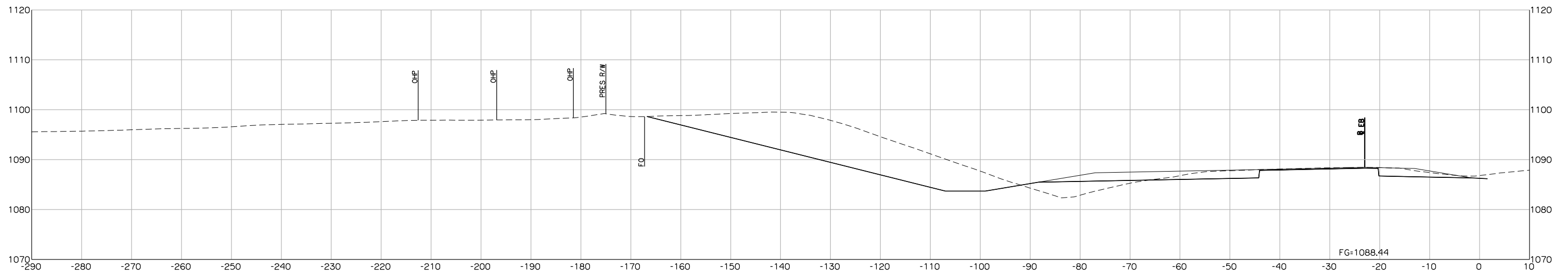

3012+00.00

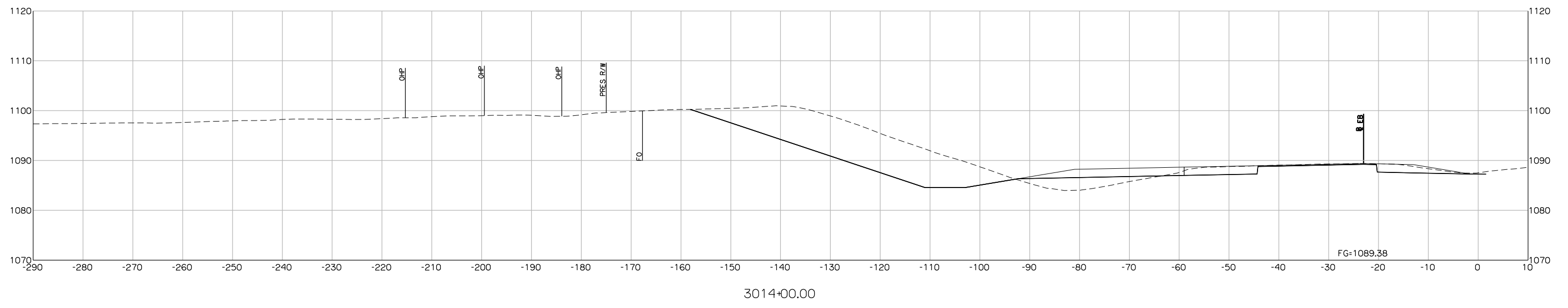
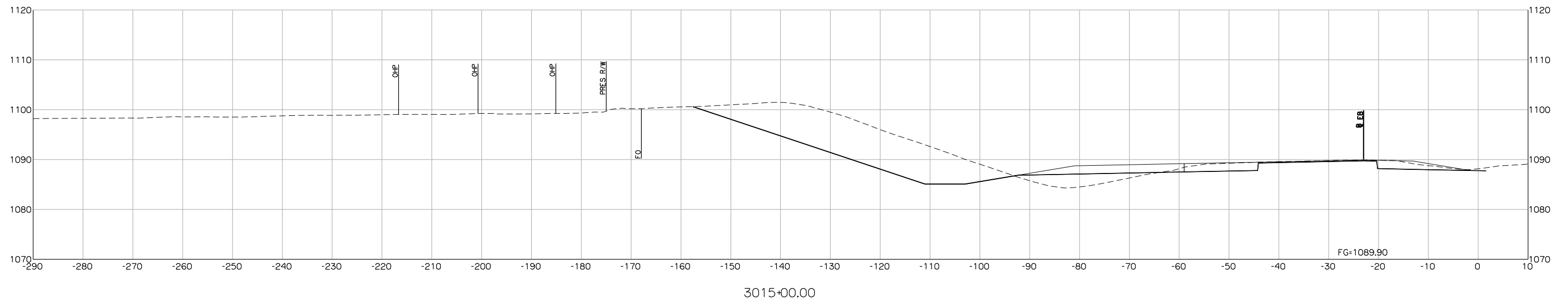

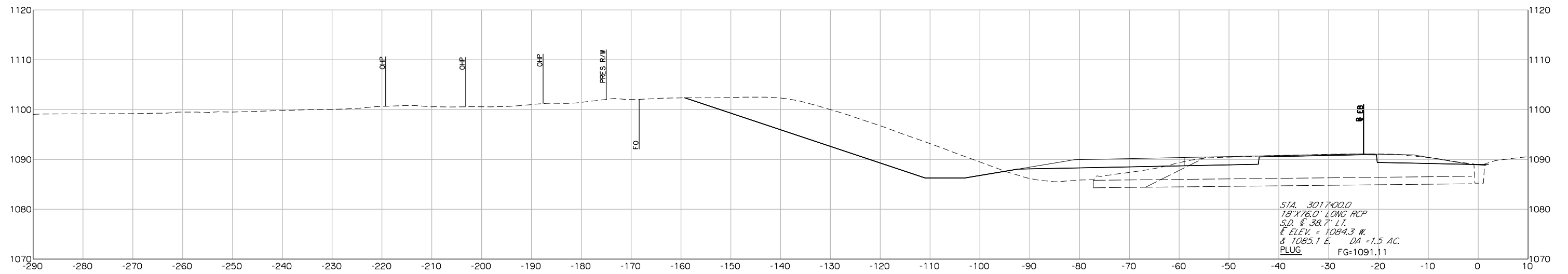

3017+00.00

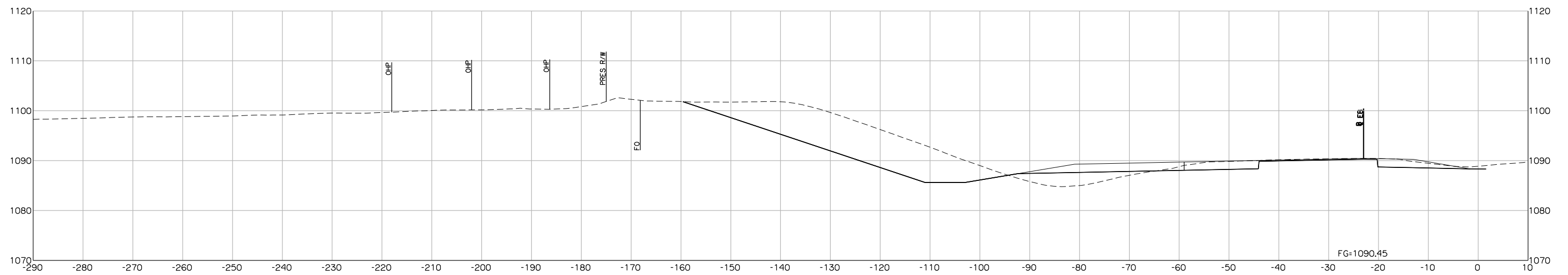

3016+00.00

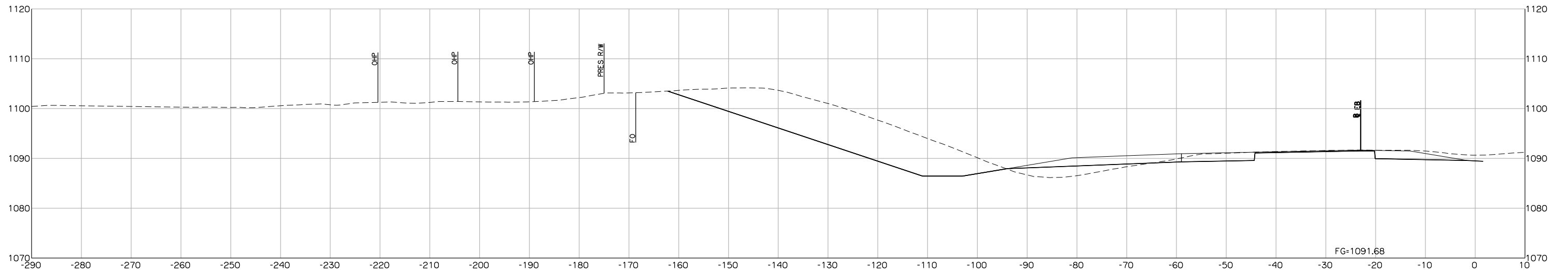

3018+00.00

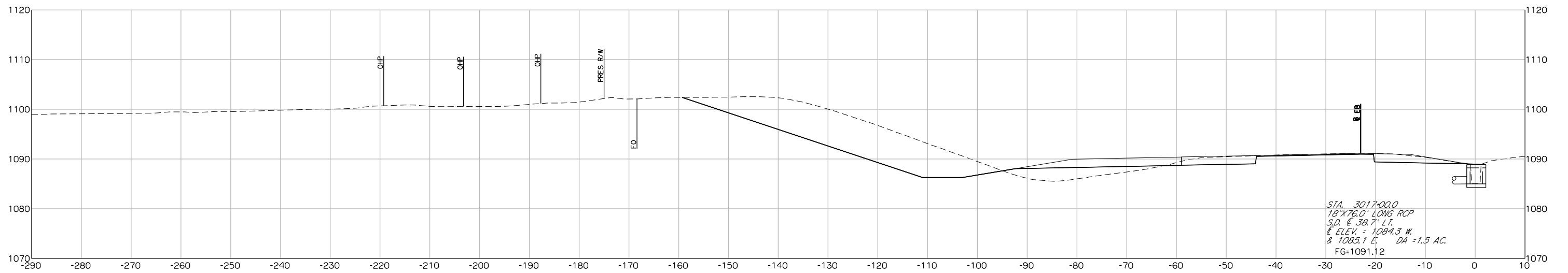

3017+02.00

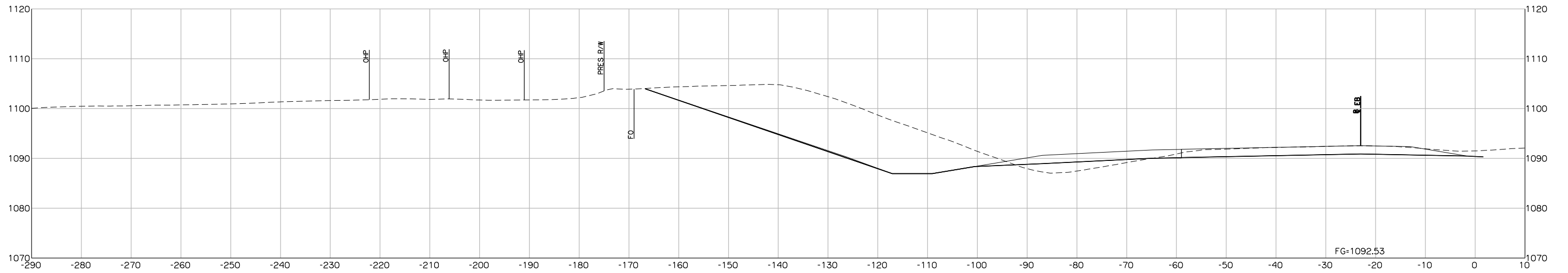

3019+50.06

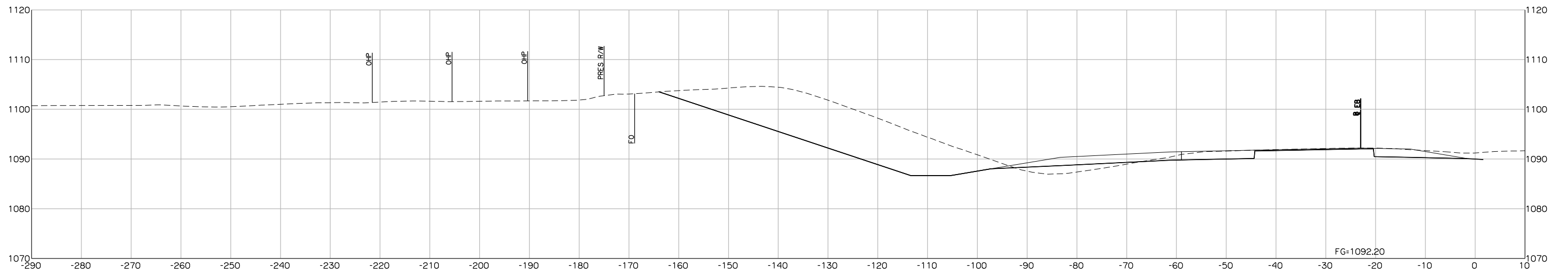

3019+00.00

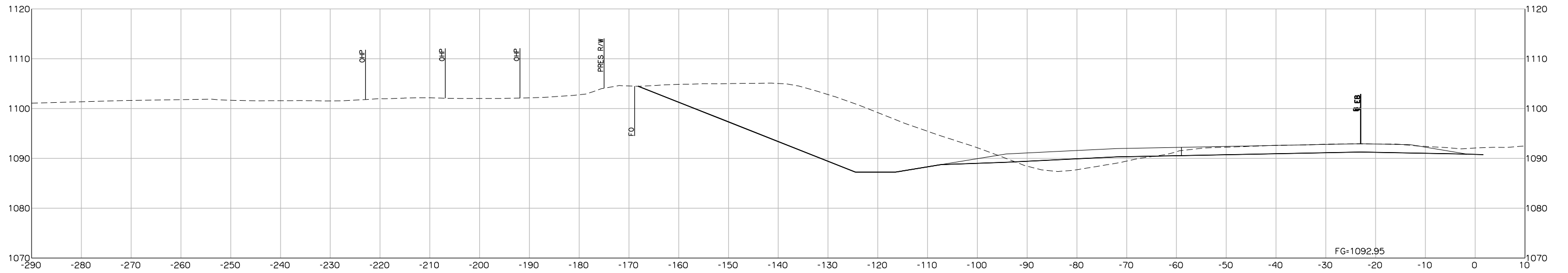

3020+15.19

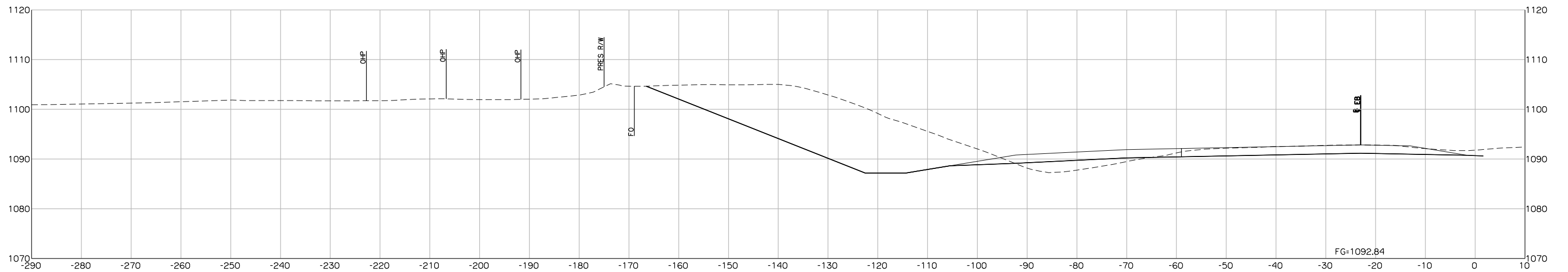

3020+00.00

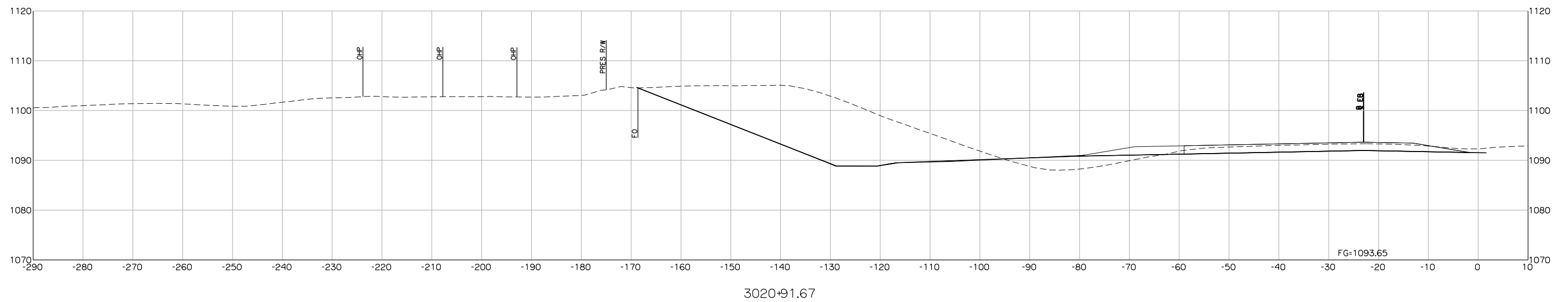
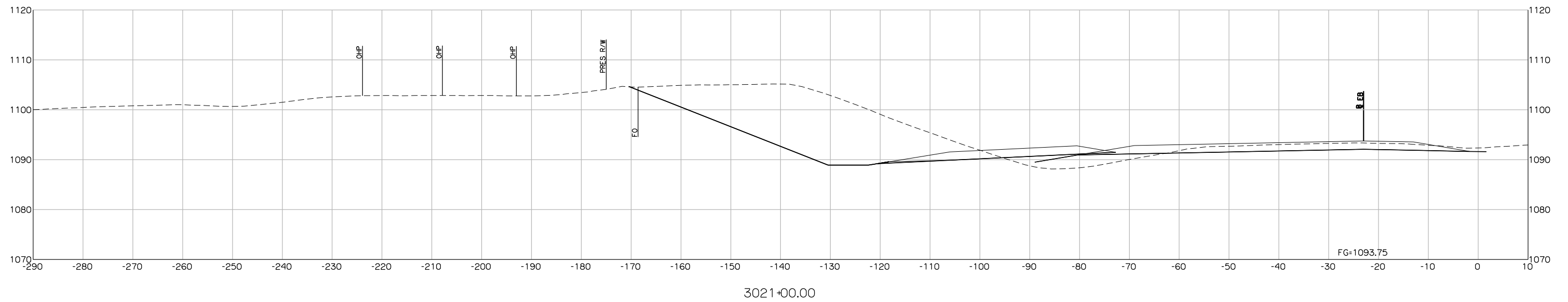

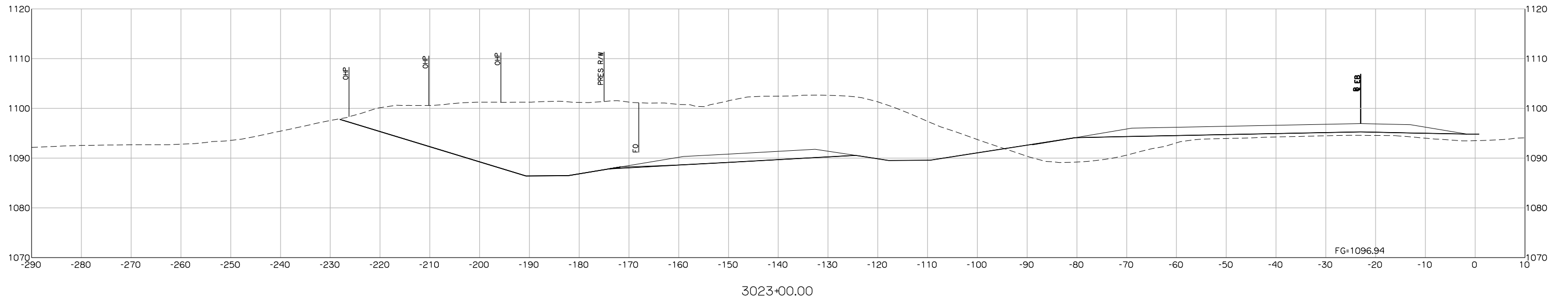

3023+00.00

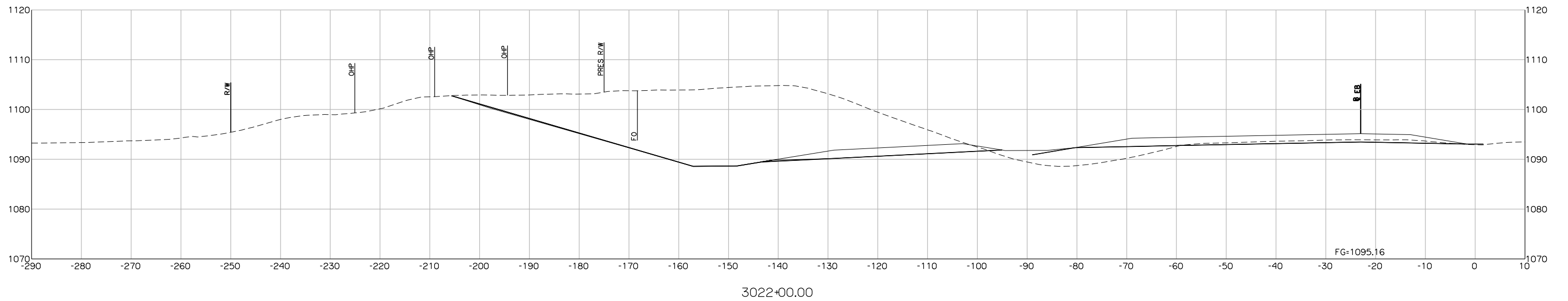

3022+00.00

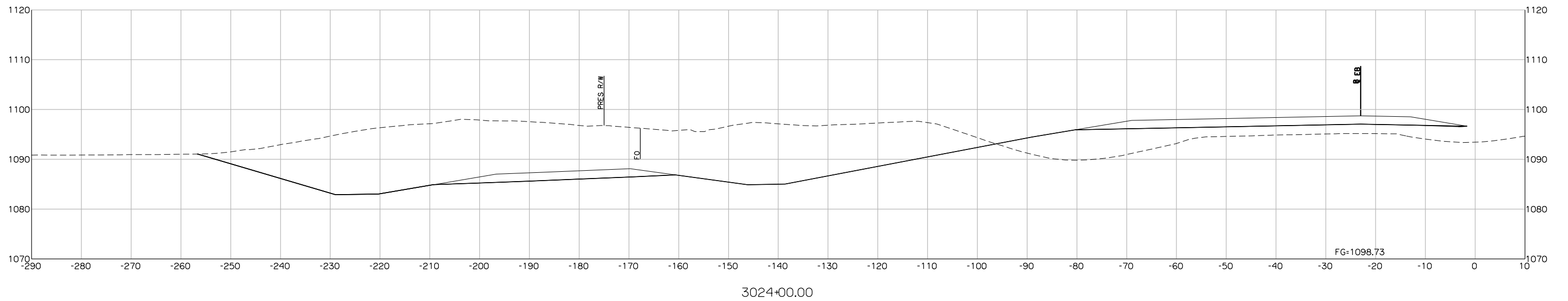
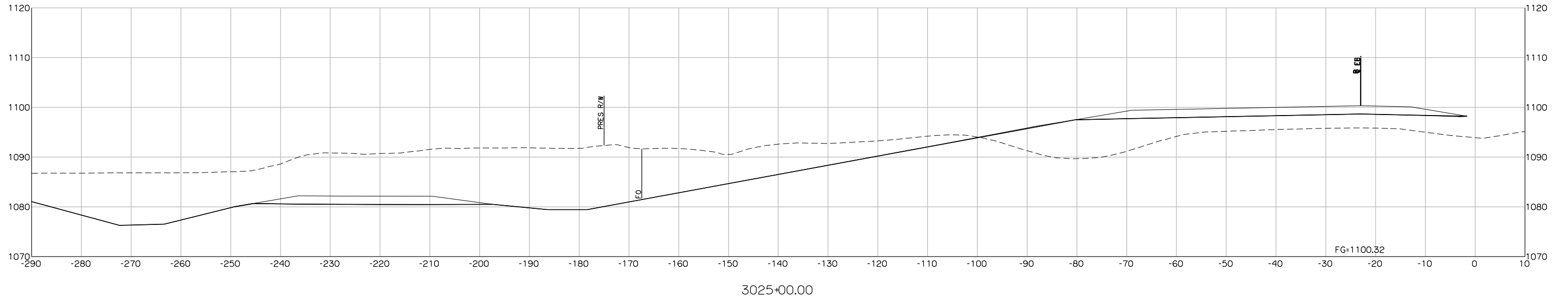

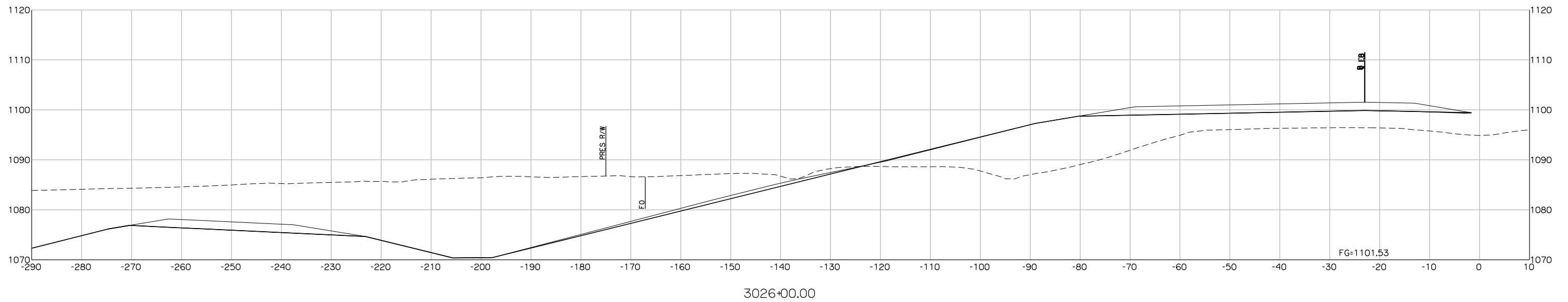
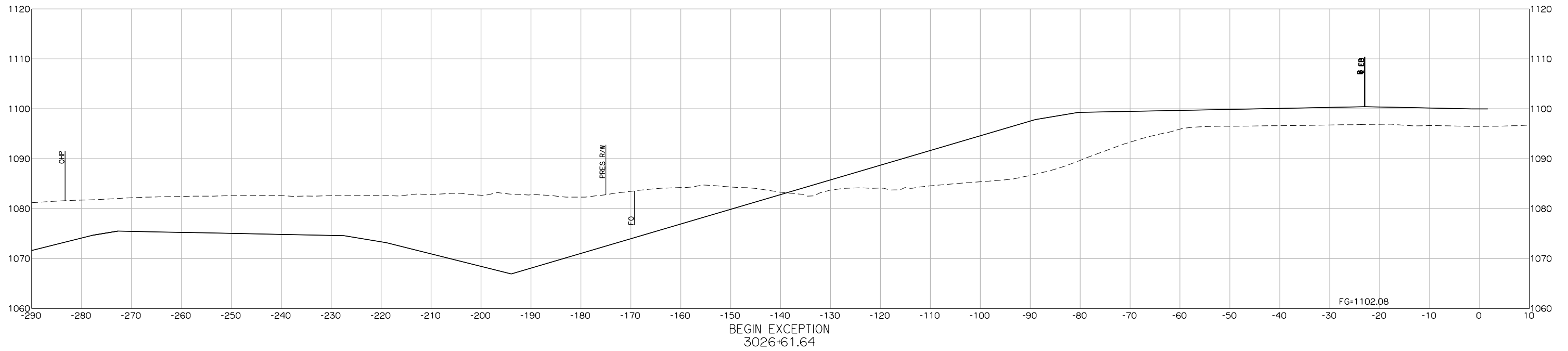

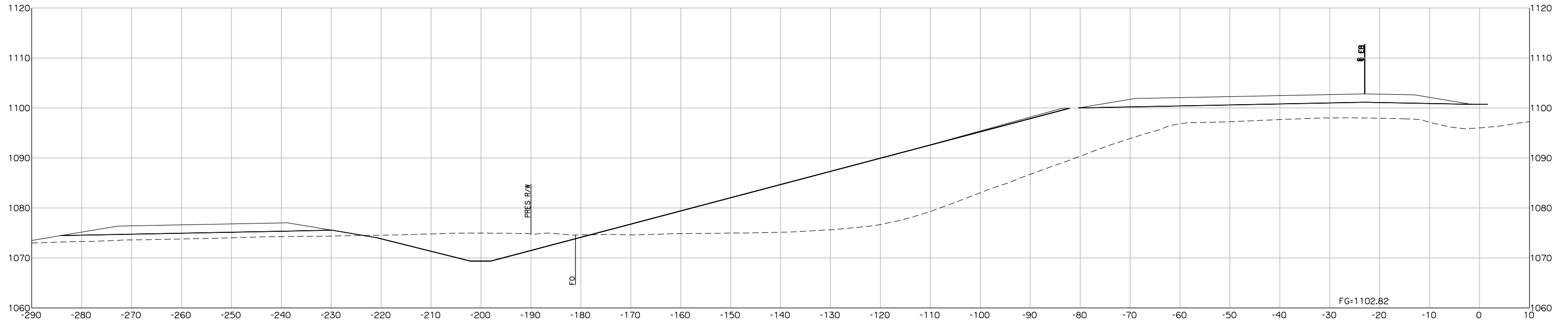

3029+00.00

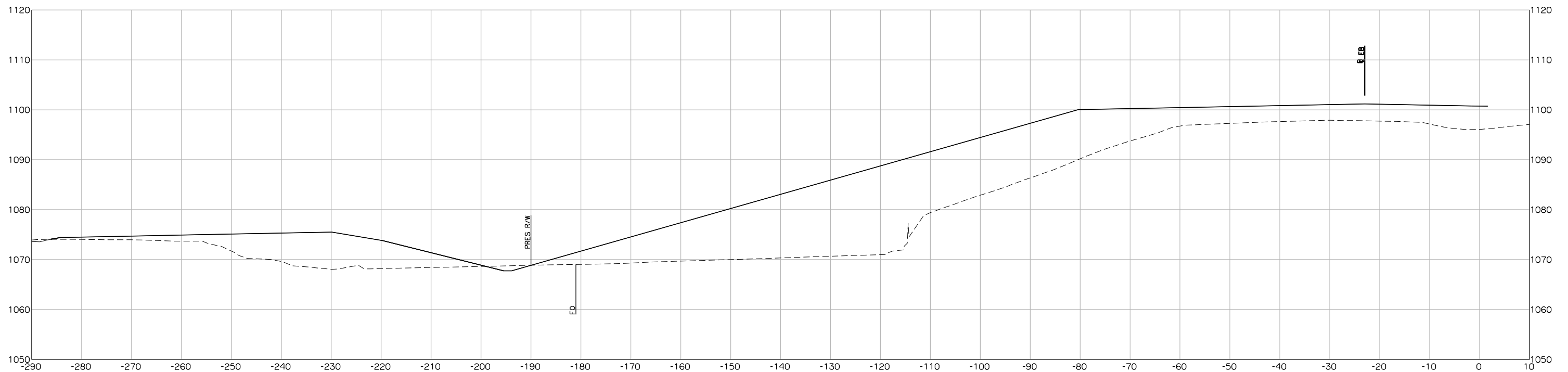

END EXCEPTION
3028+71.64

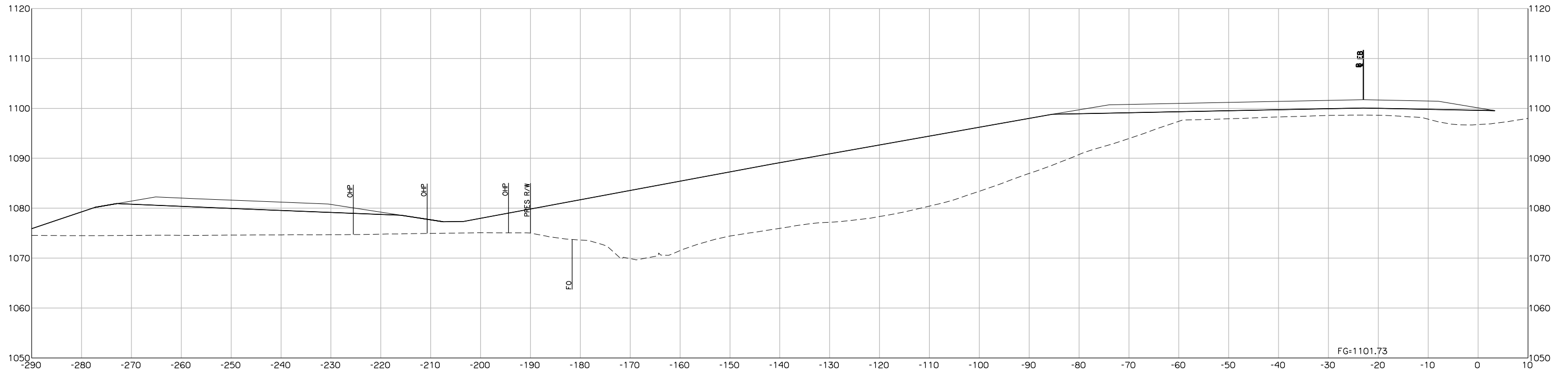

3031+00.00

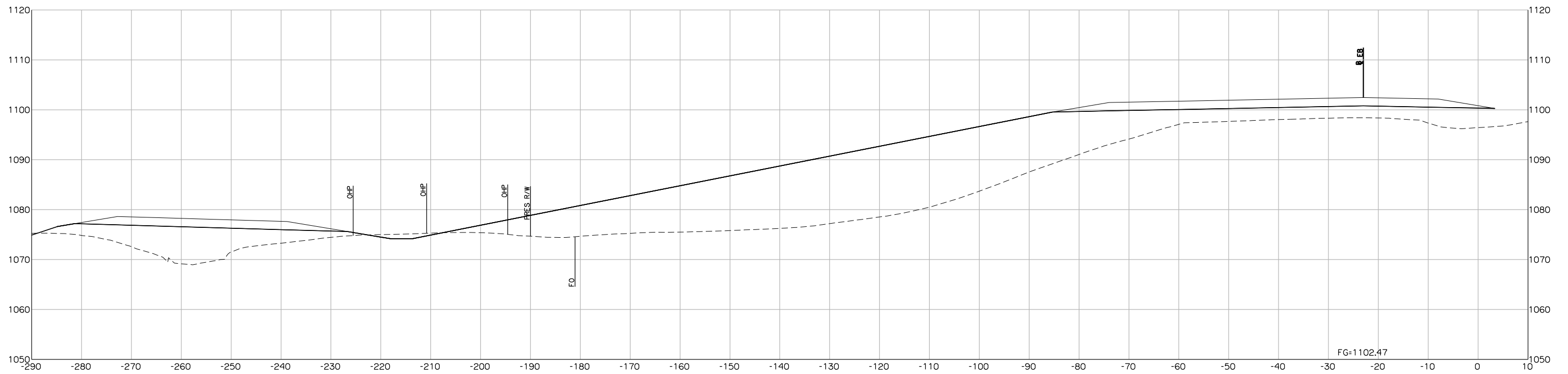

3030+00.00

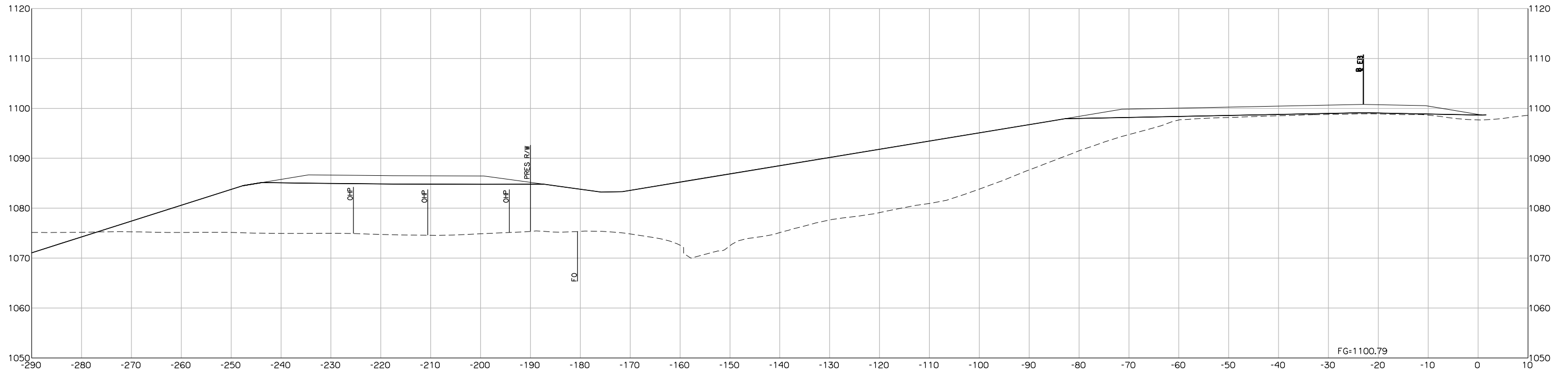

3032+00.00

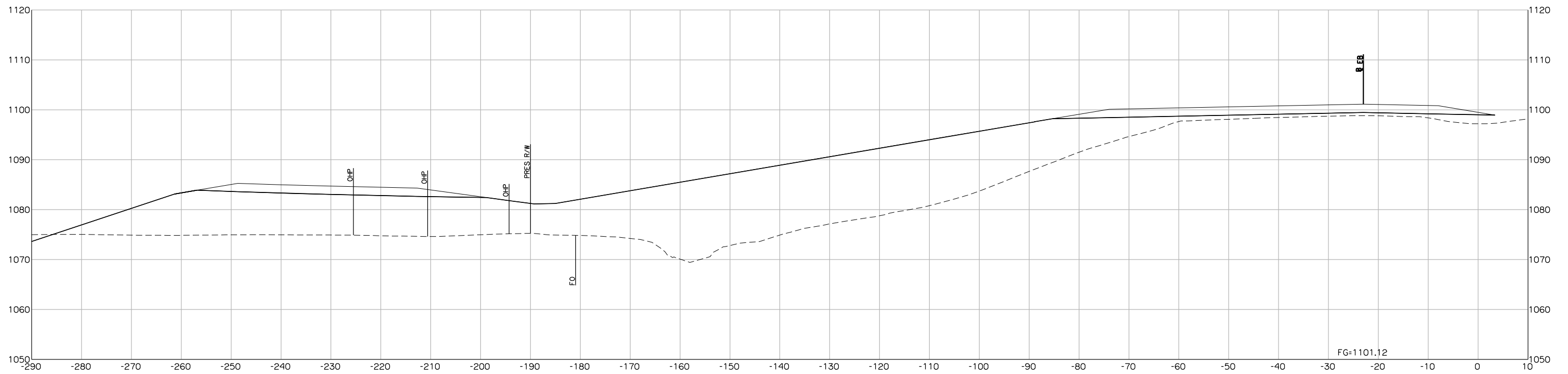

3031+64.63

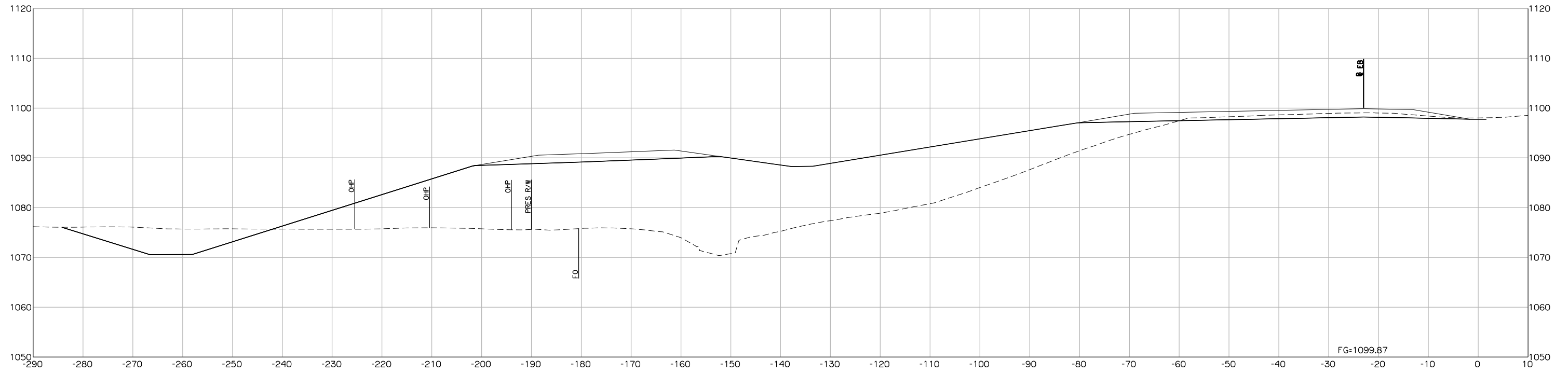

3033+00.00

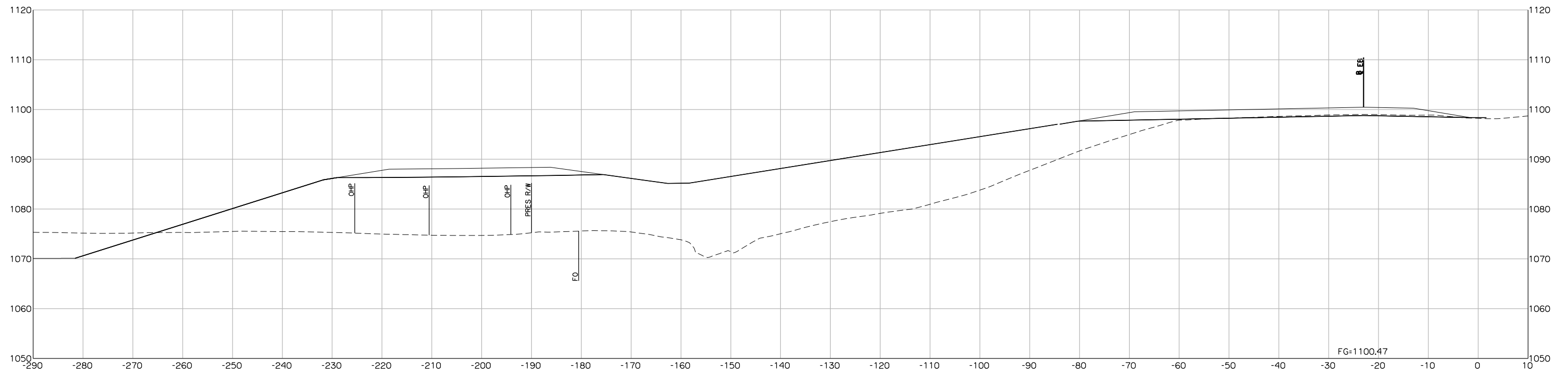

3032+34.63

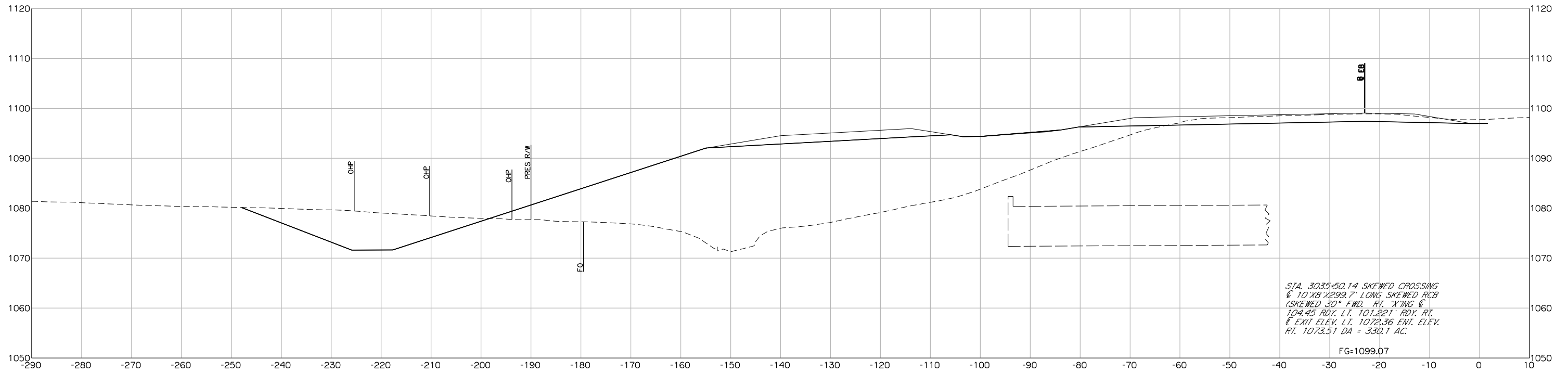

STA. 3035+50.14 SKEWED CROSSING
@ 10' X 8' X 299.7' LONG SKEWED PCB
(SKEWED 30° FWD. RT. X'ING @
104.45 RDY. LT. 101.221' RDY. RT.
& EXIT ELEV. LT. 1072.36 ENT. ELEV.
RT. 1073.51 DA = 330.1 AC.

FG-1099.07

3034+39.55

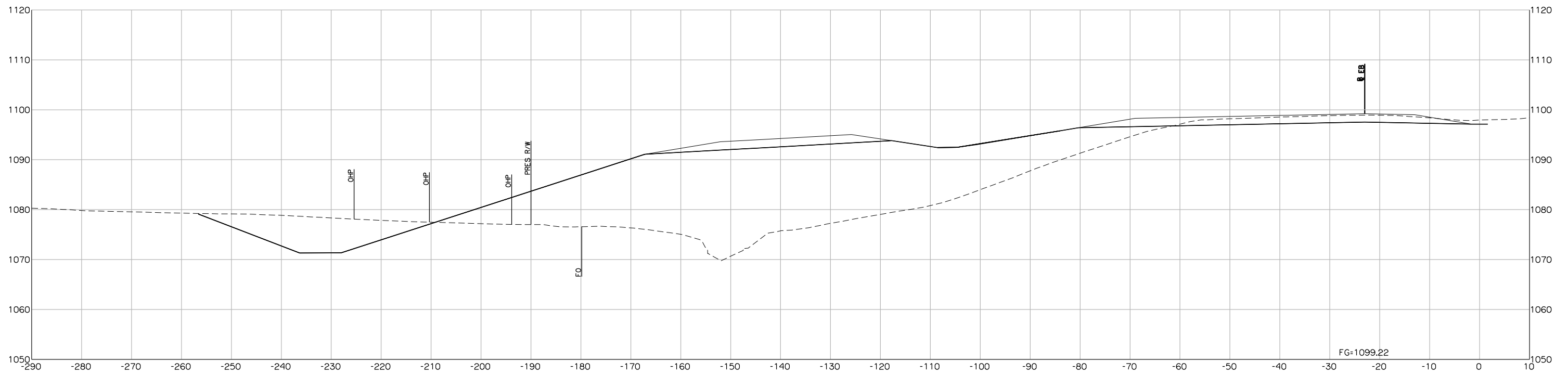

FG-1099.22

3034+00.00

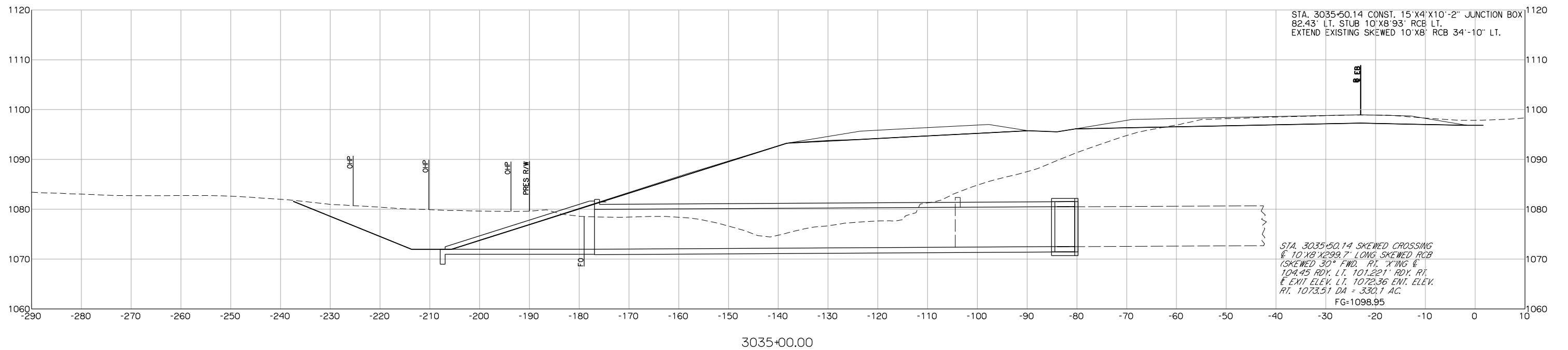
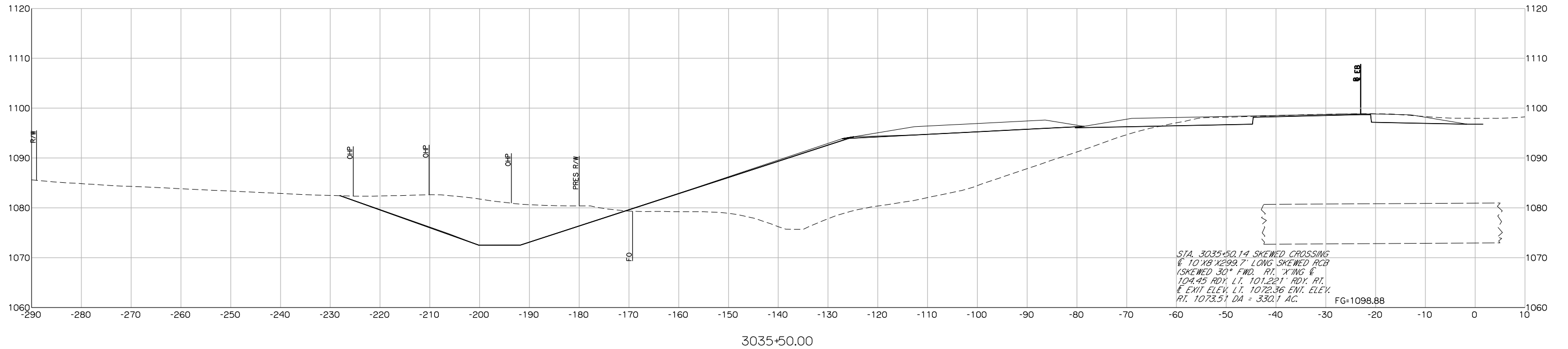

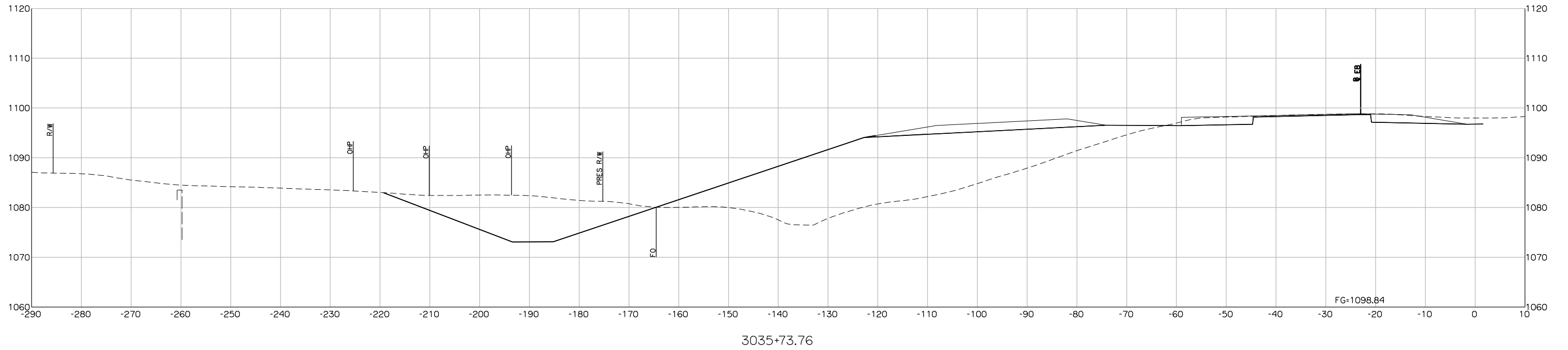

3035+73.76

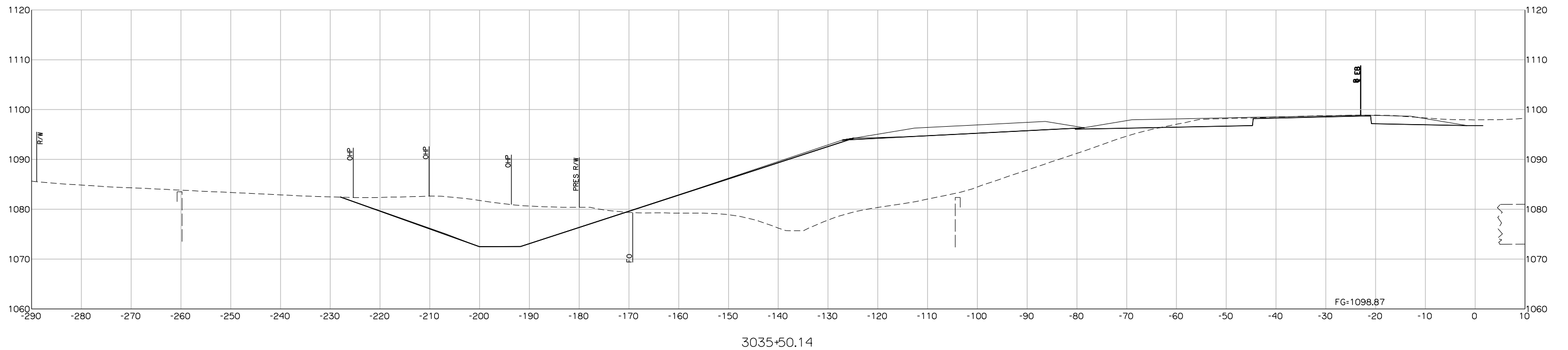

3035+50.14

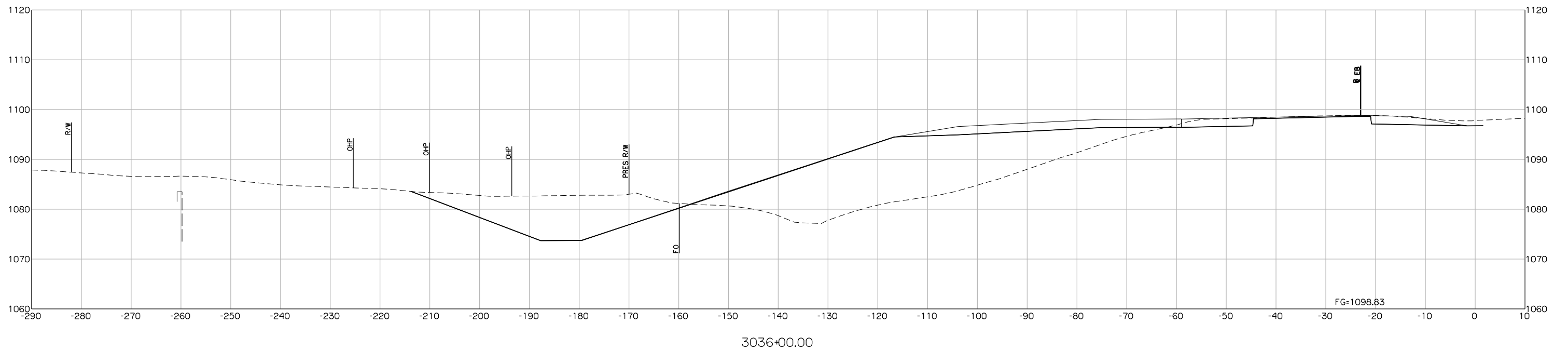
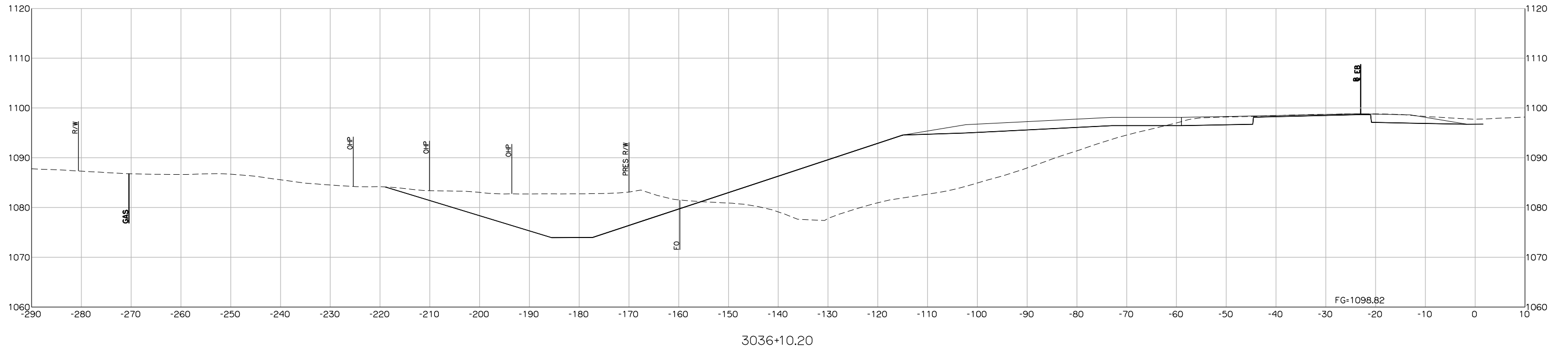

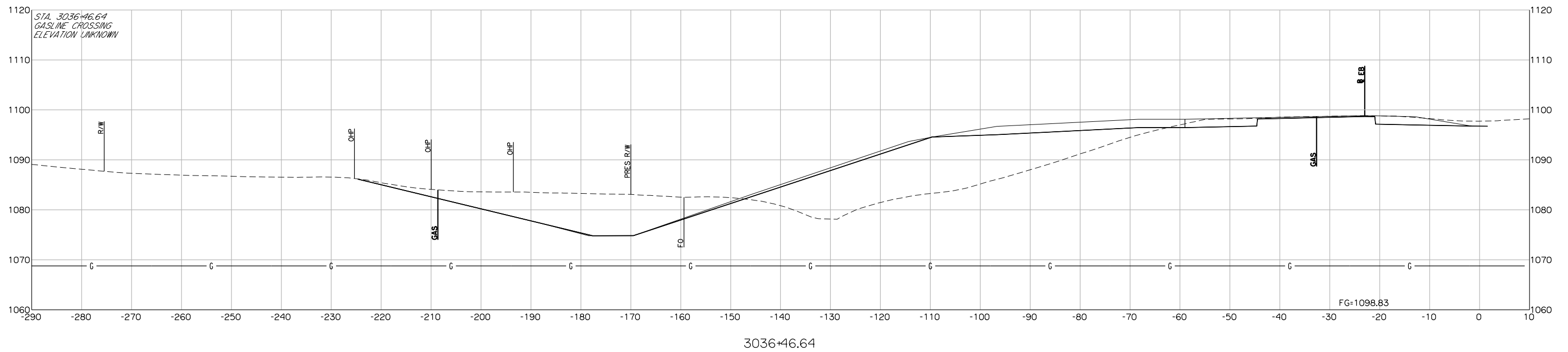
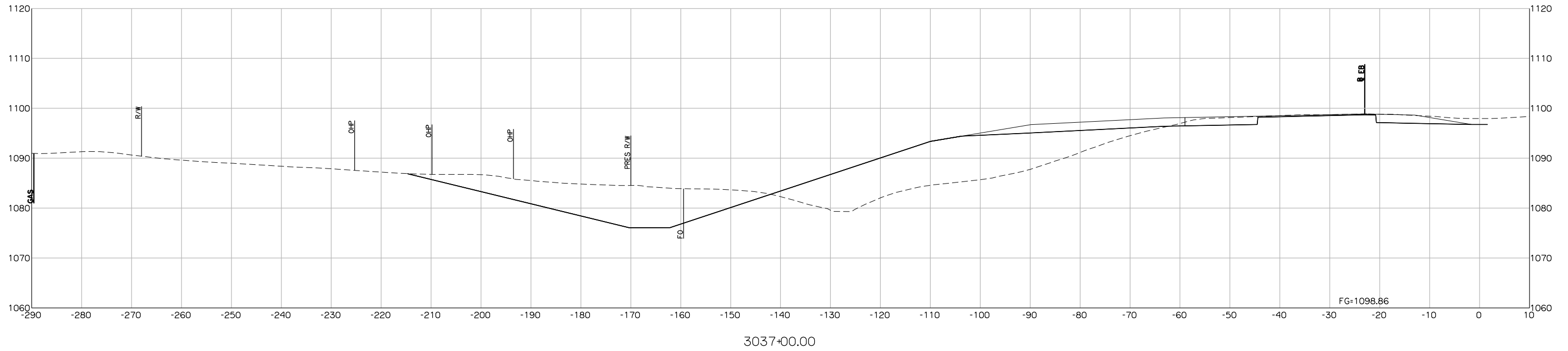

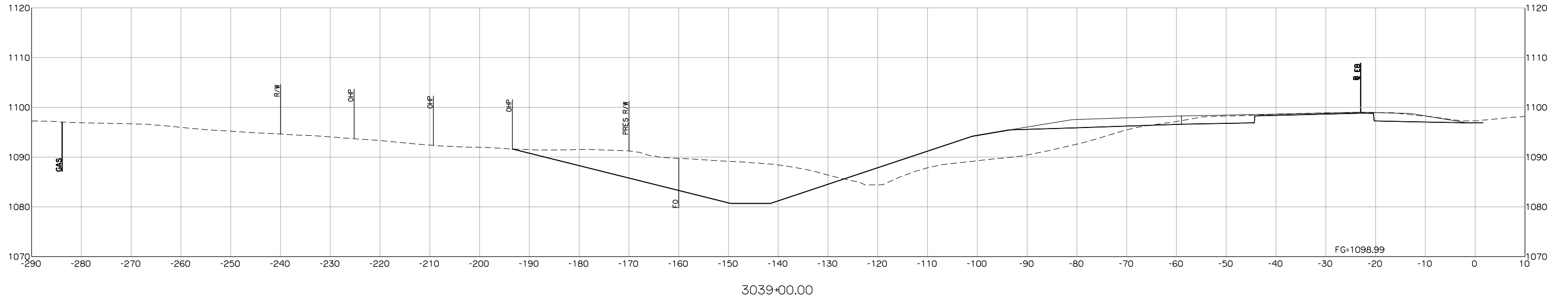

3039+00.00

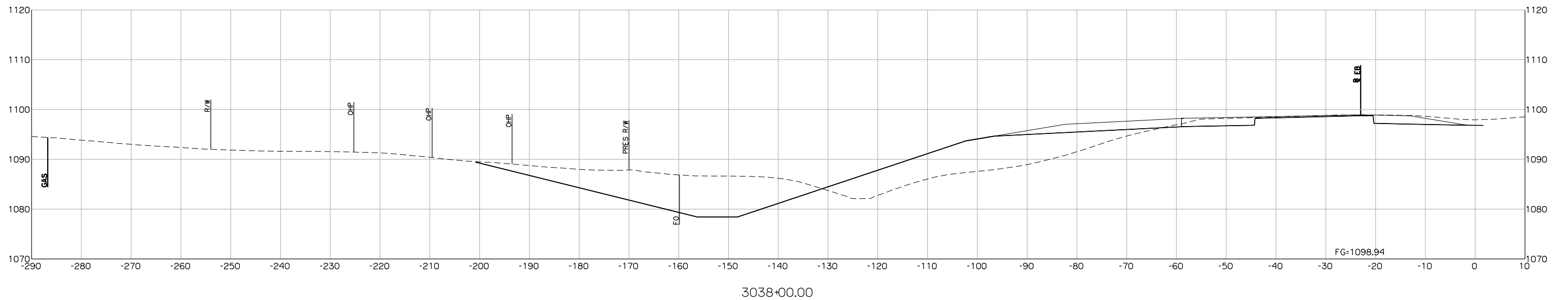

3038+00.00

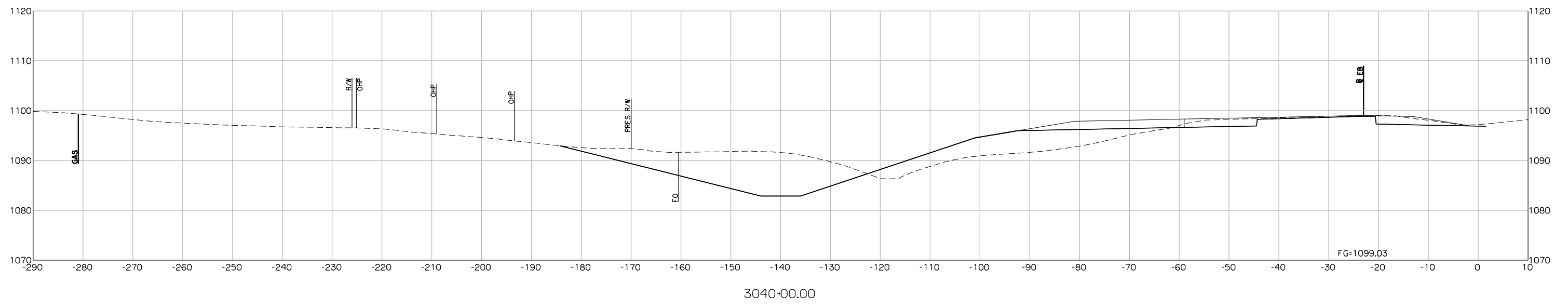
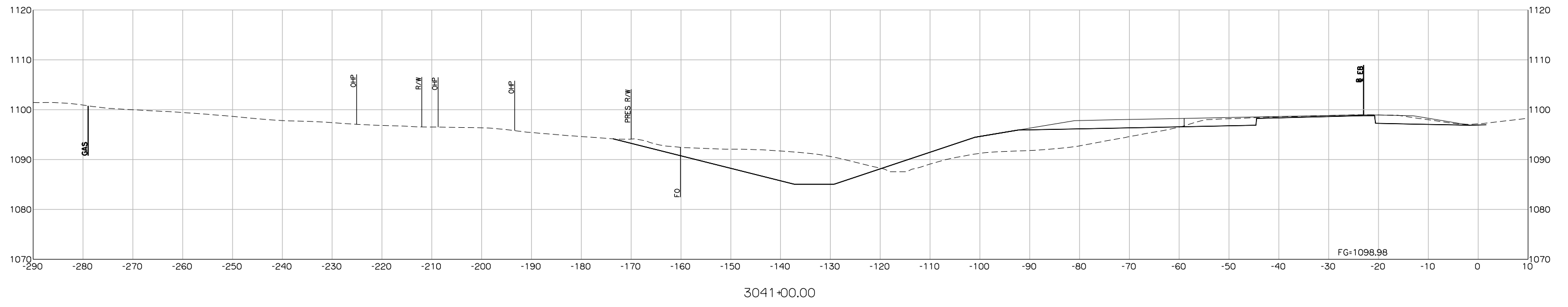

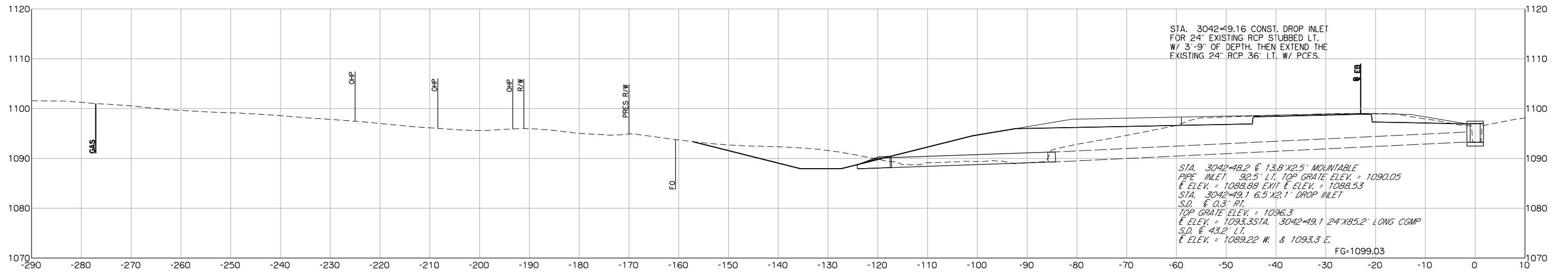

3042+49.16

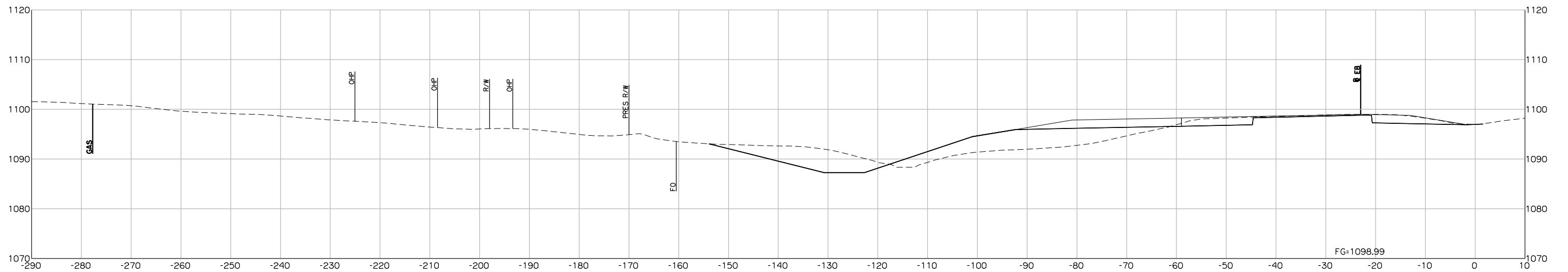

3042+00.00

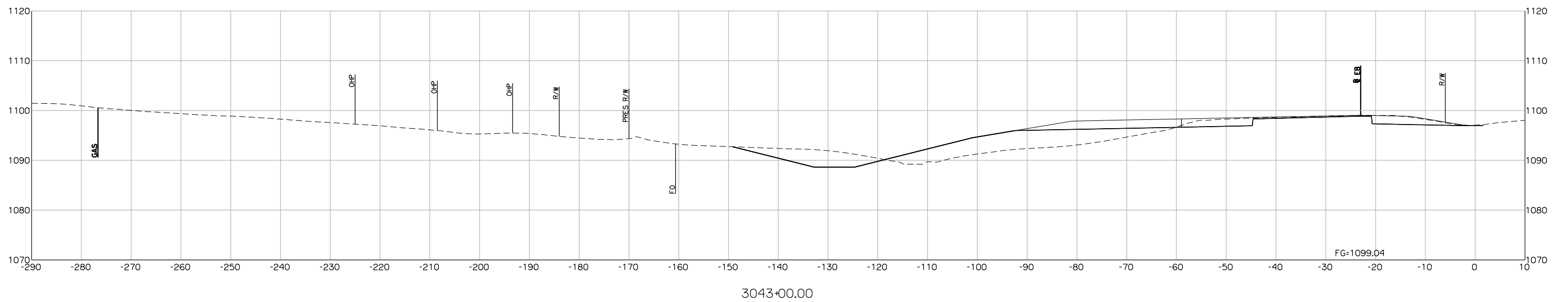
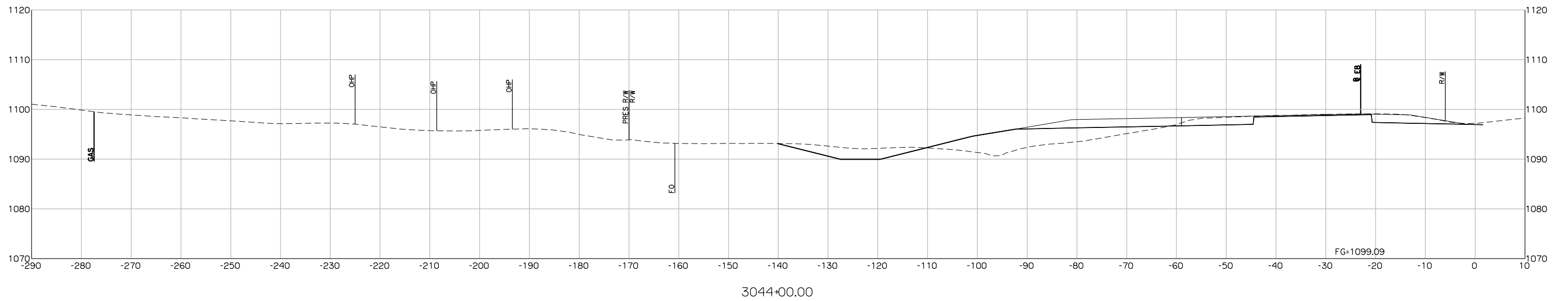
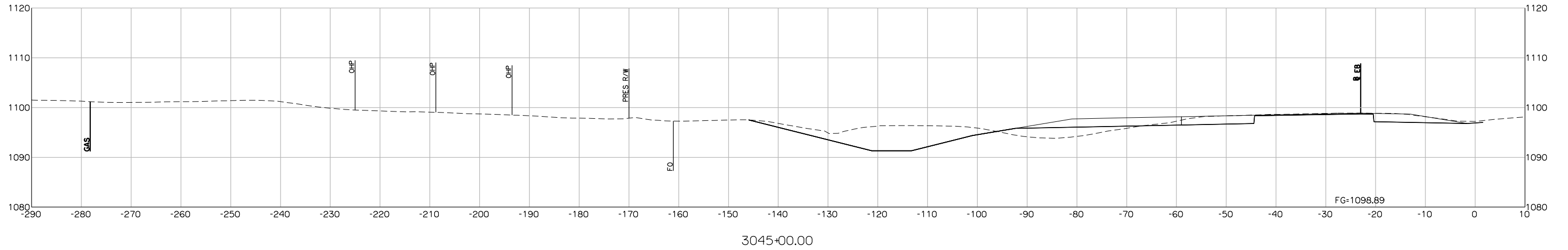

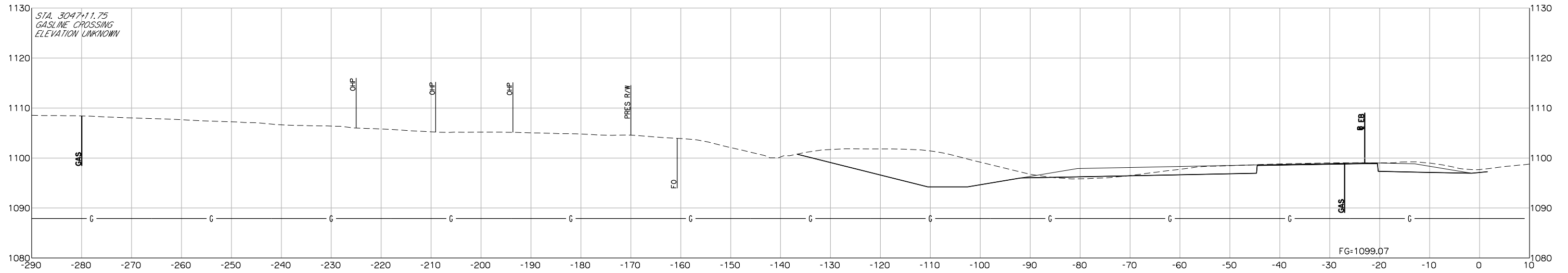

3047+11.75

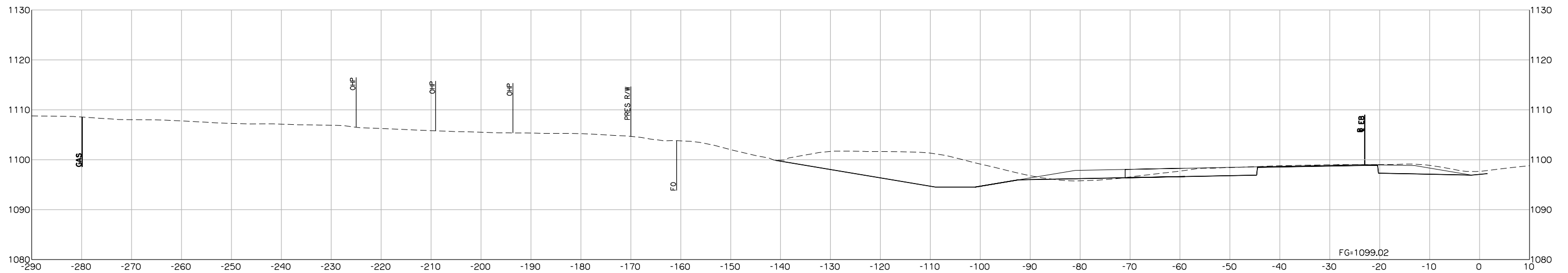

3047+00.00

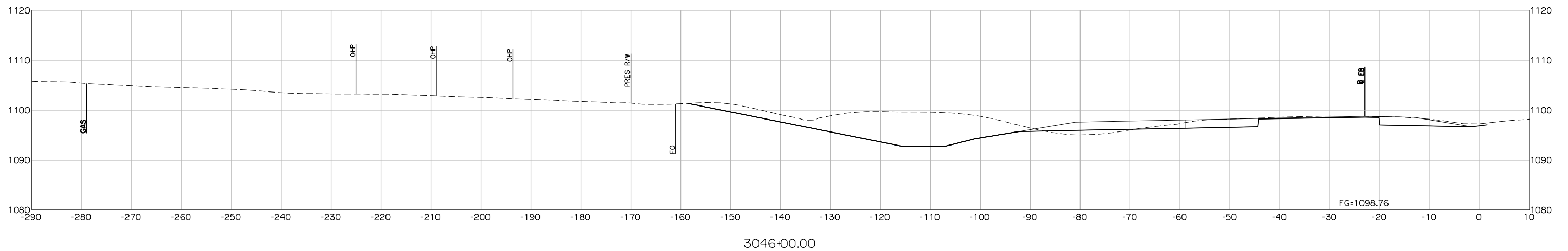

3046+00.00

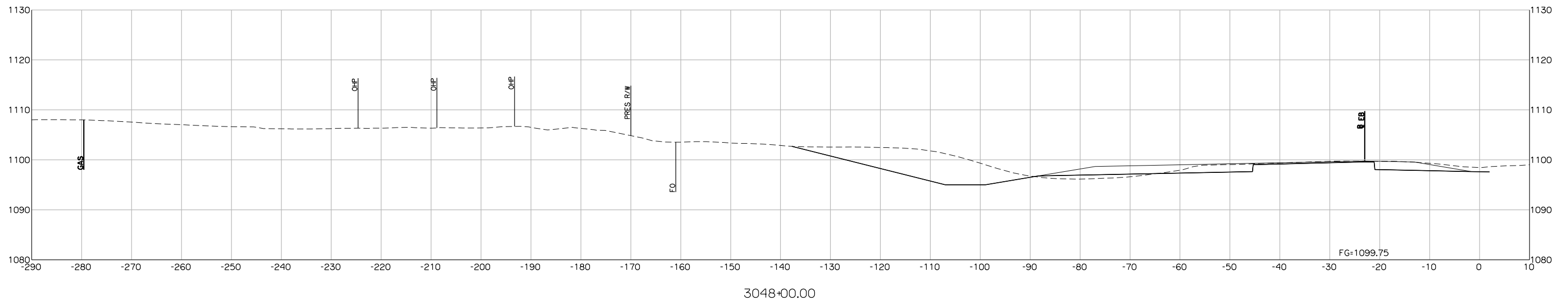
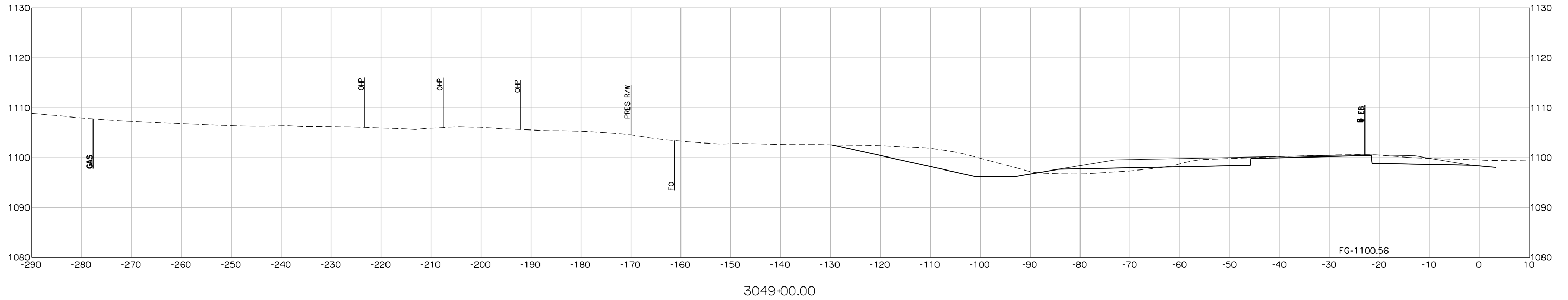

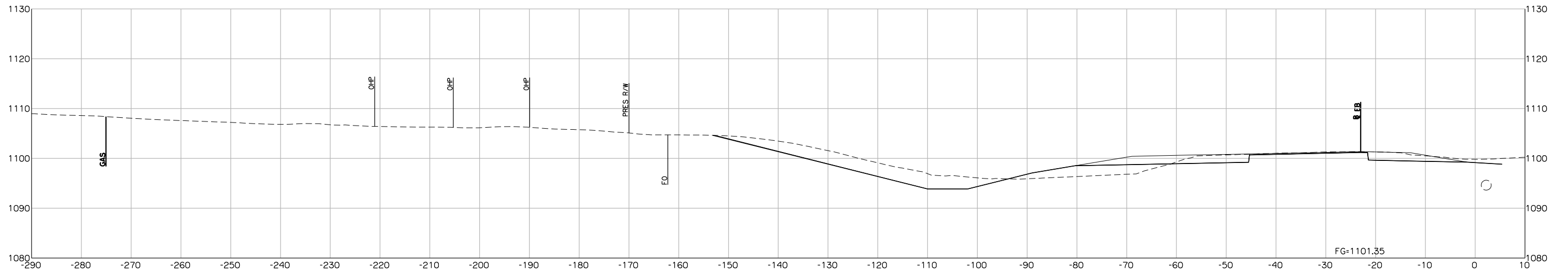

3050+00.00

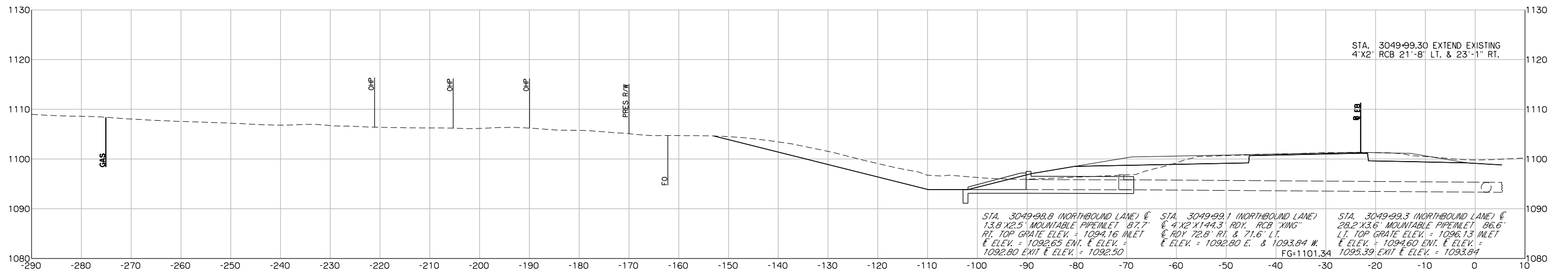

3049+99.10

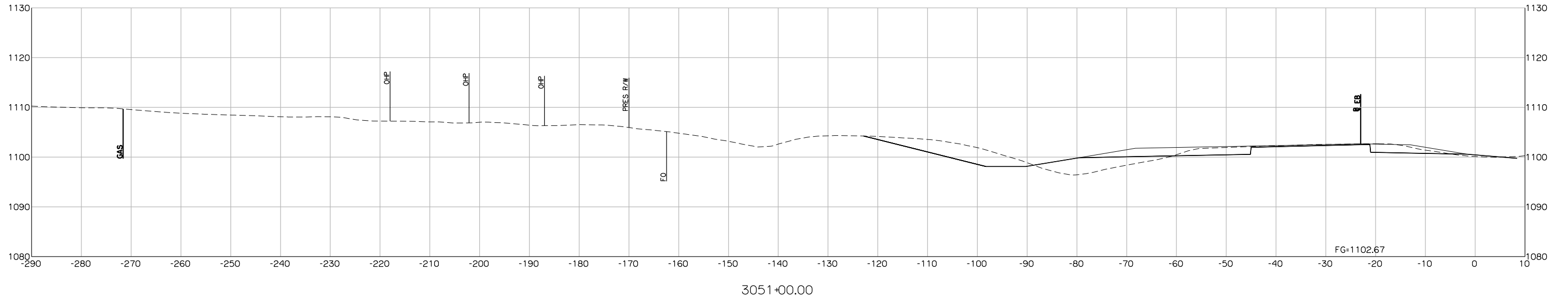

3051+00.00

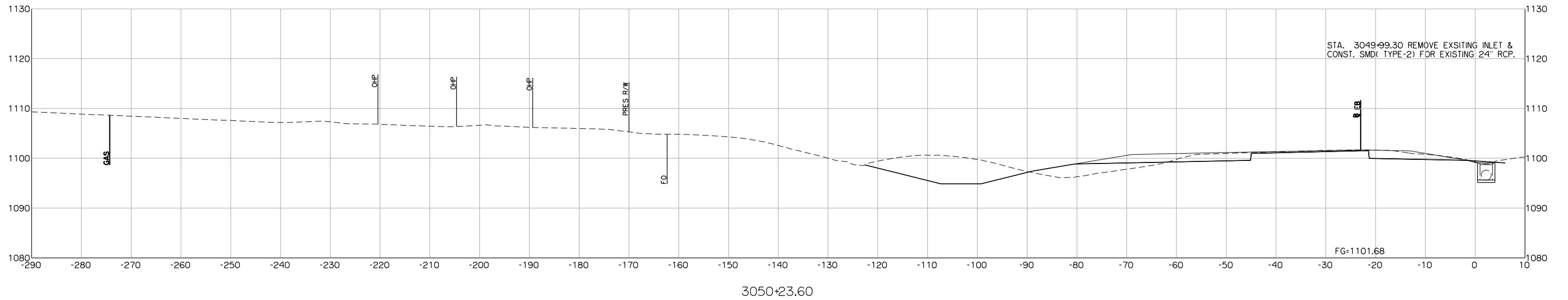

3050+23.60

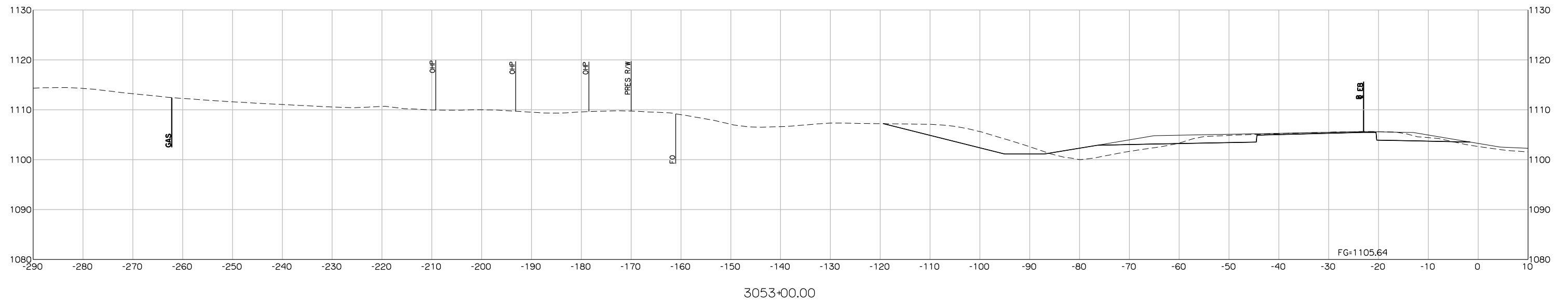

3053+00.00

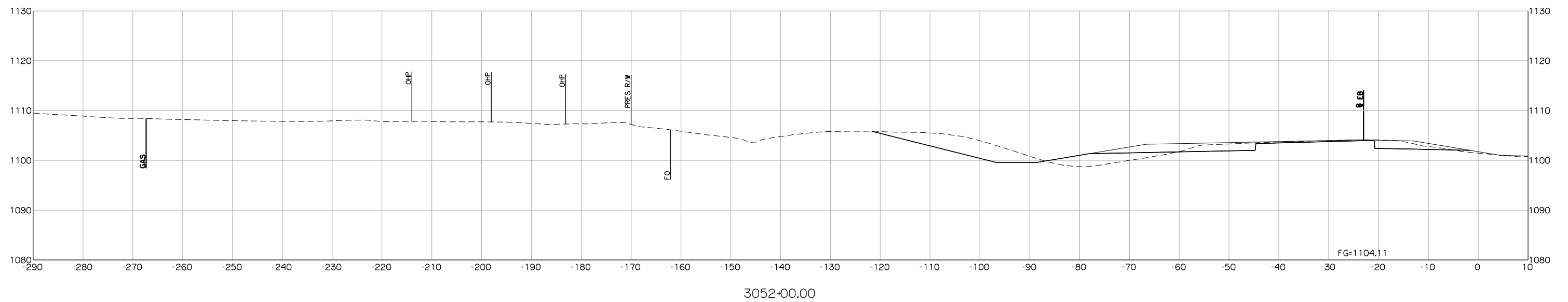

3052+00.00

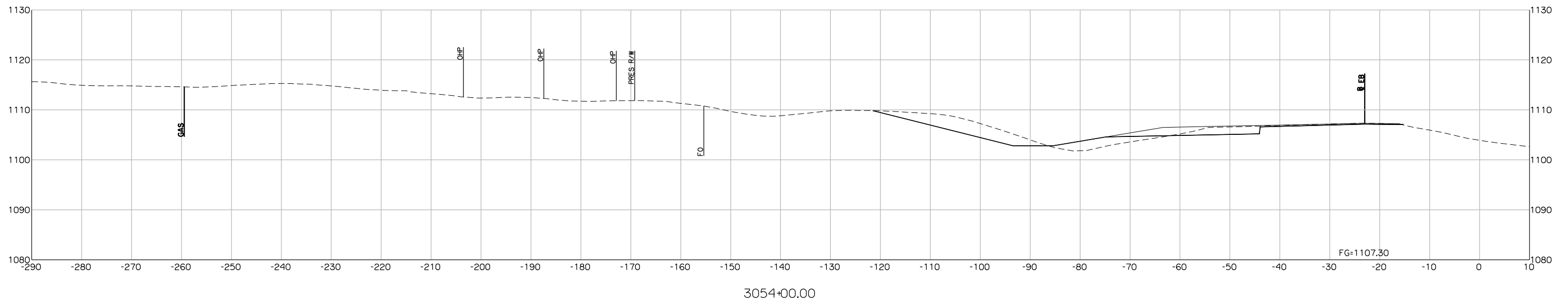
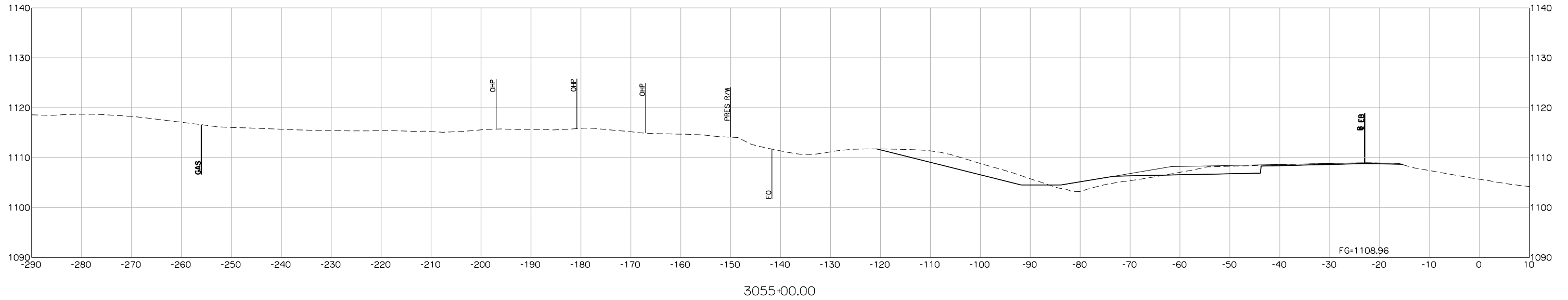

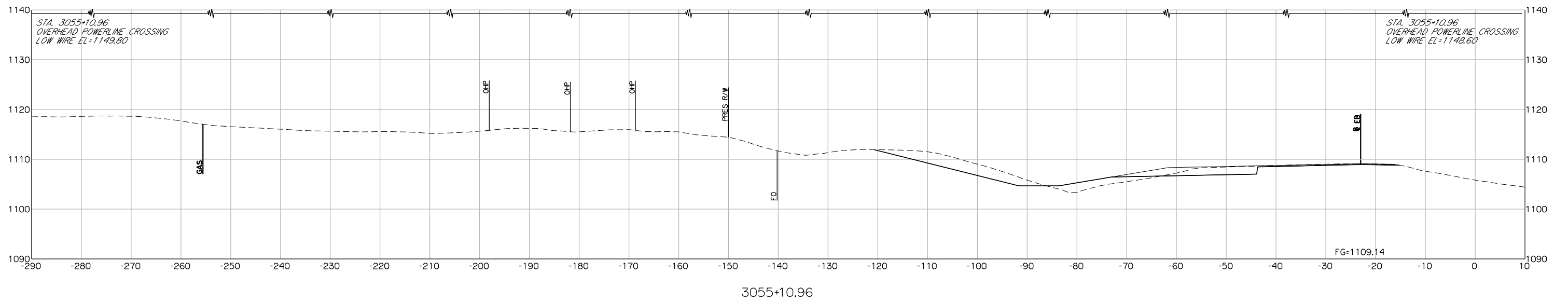
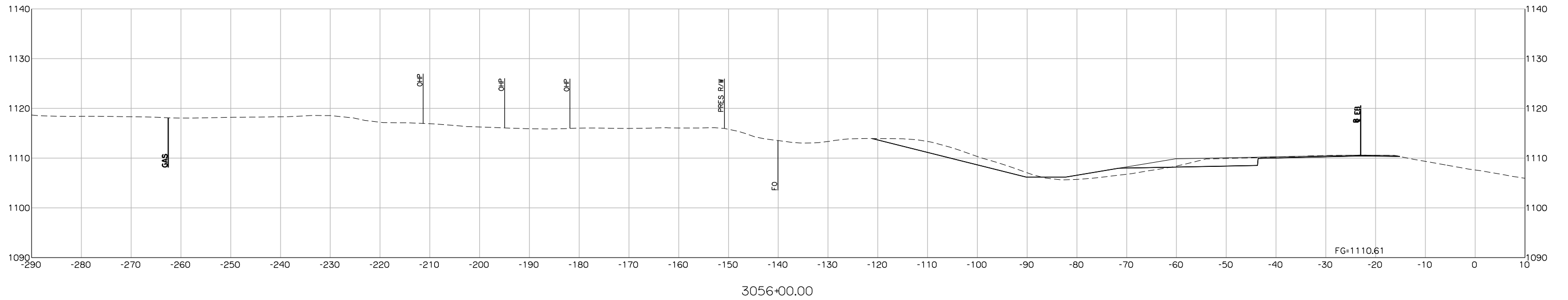

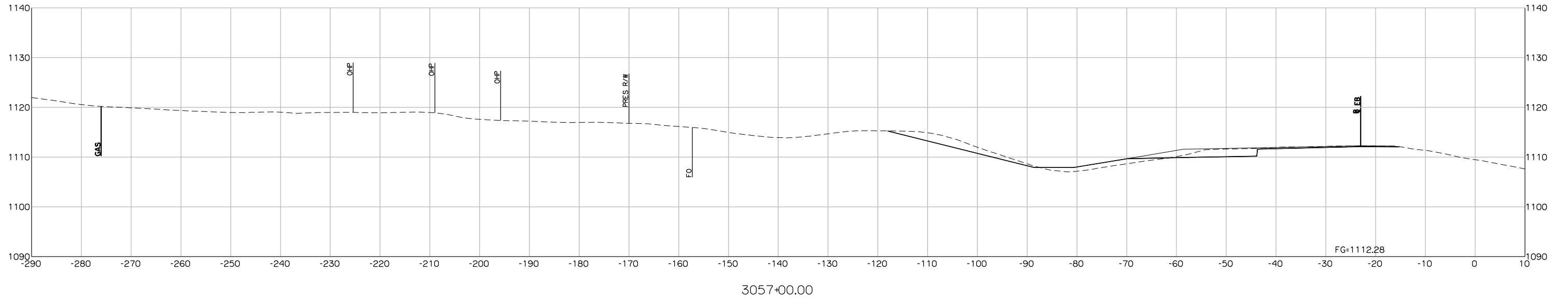

3057+00.00

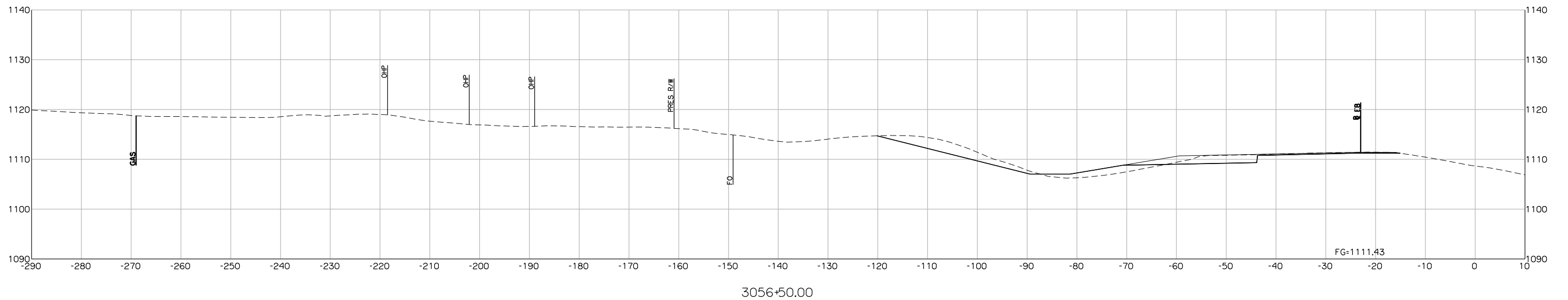

3056+50.00

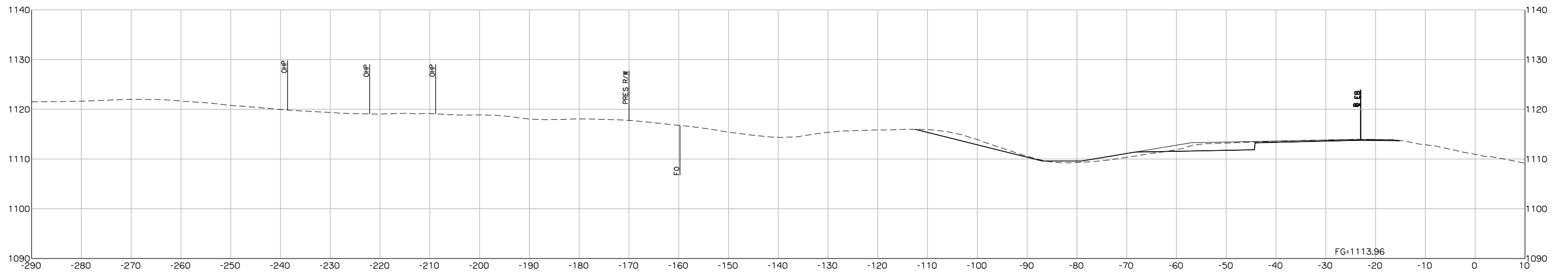
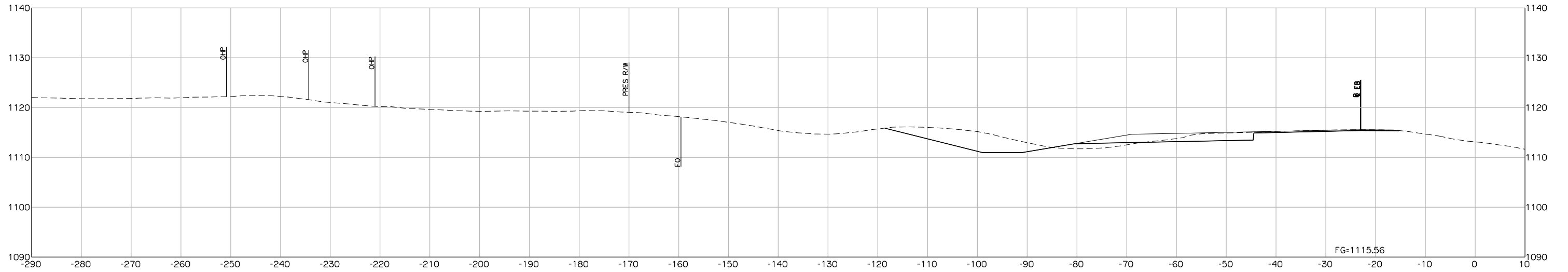

END PROJECT
3058+00.00

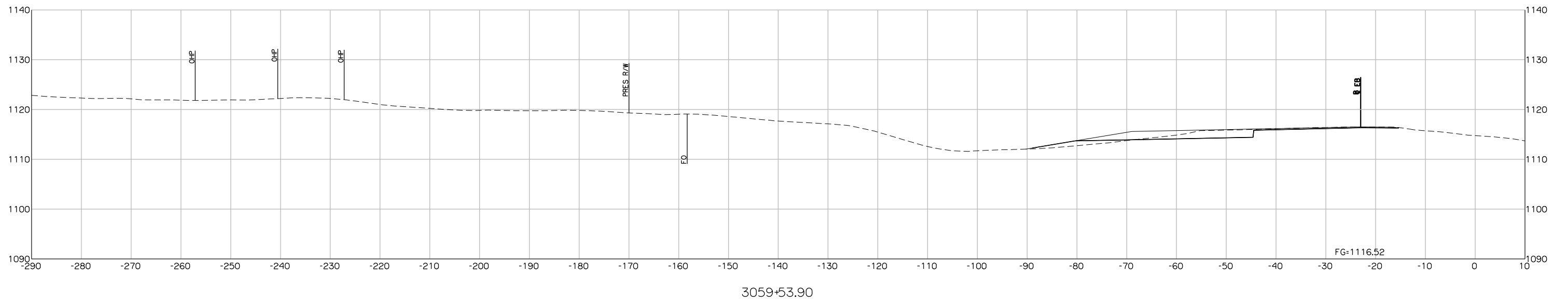

3059+53.90

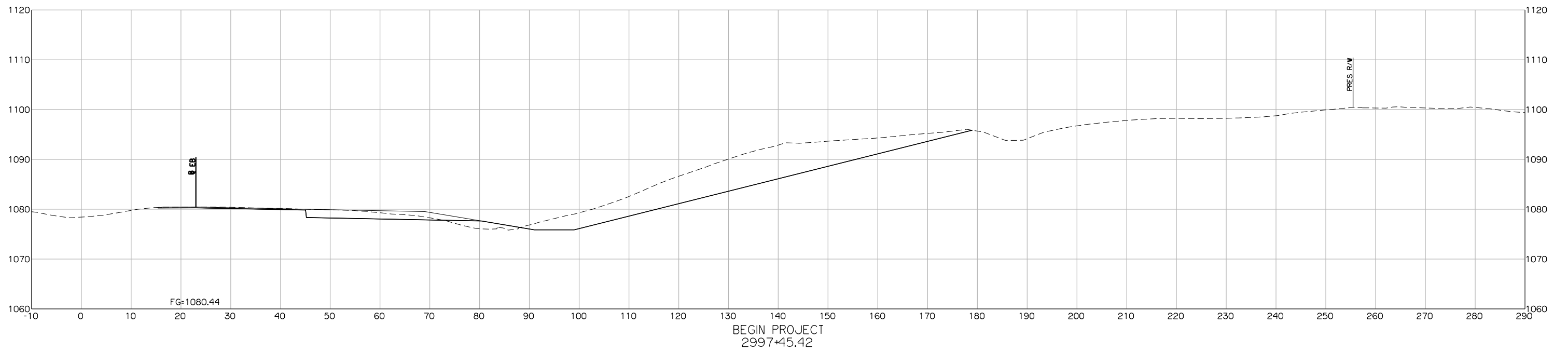
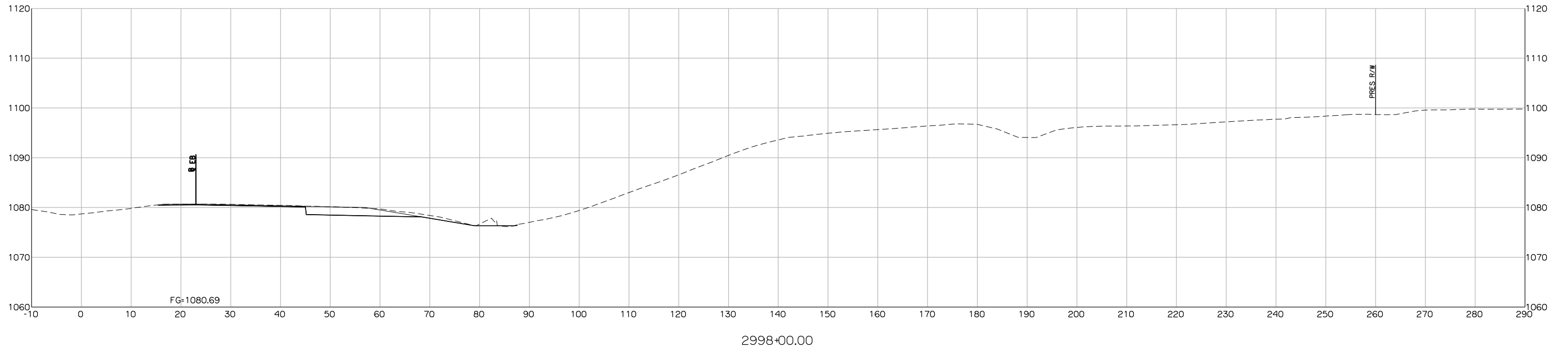

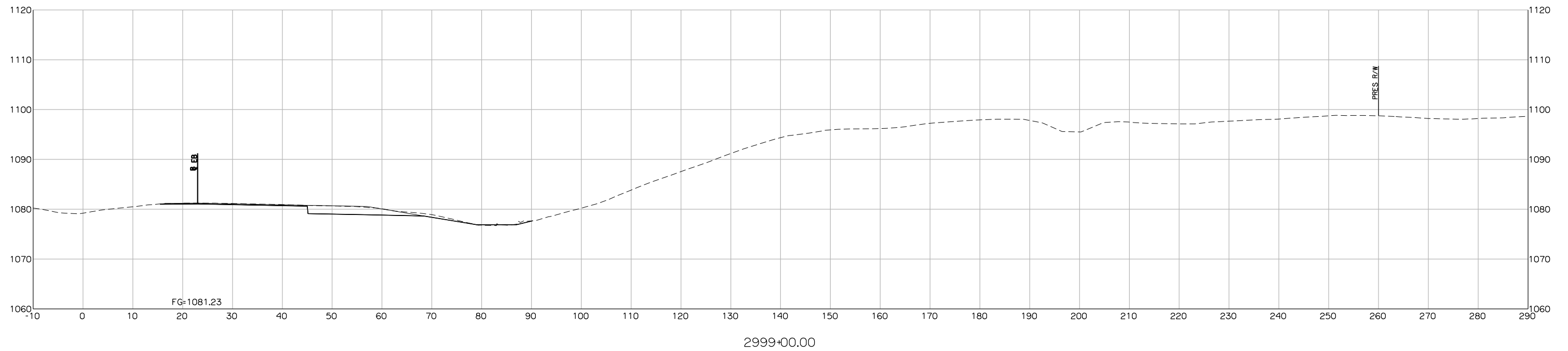
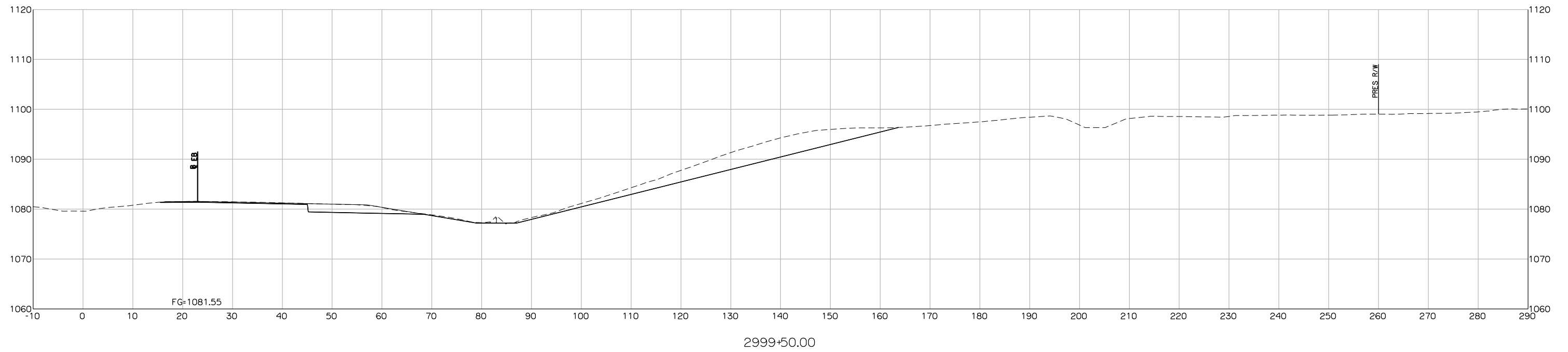

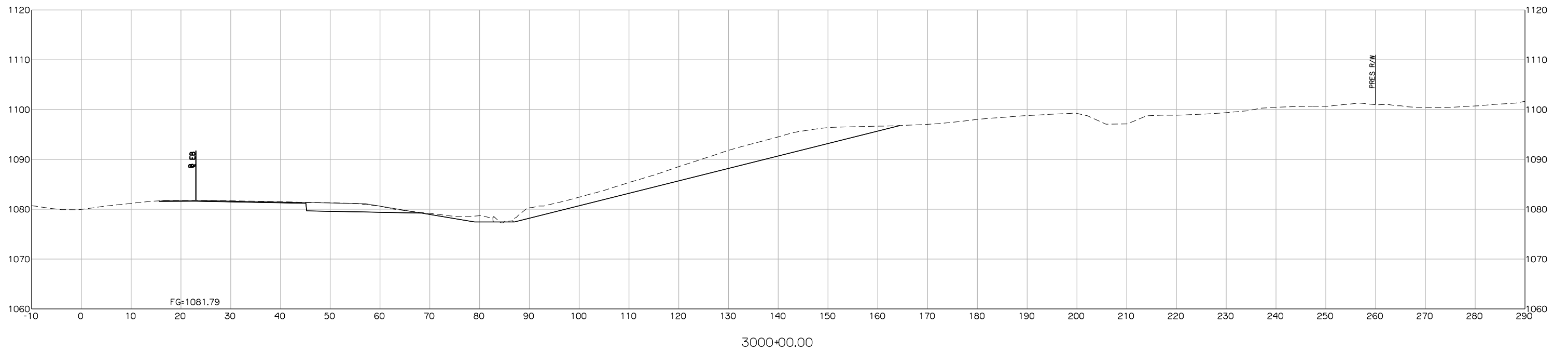
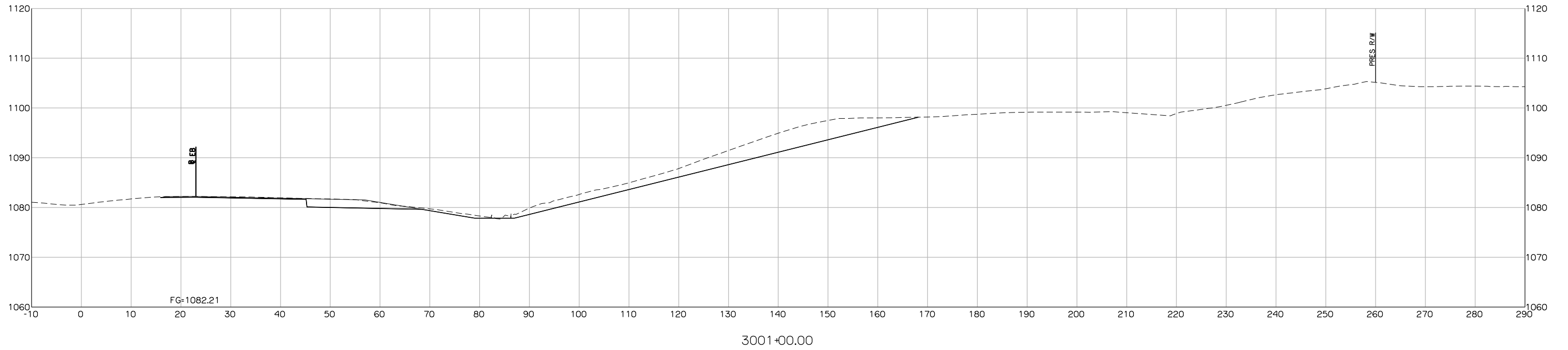

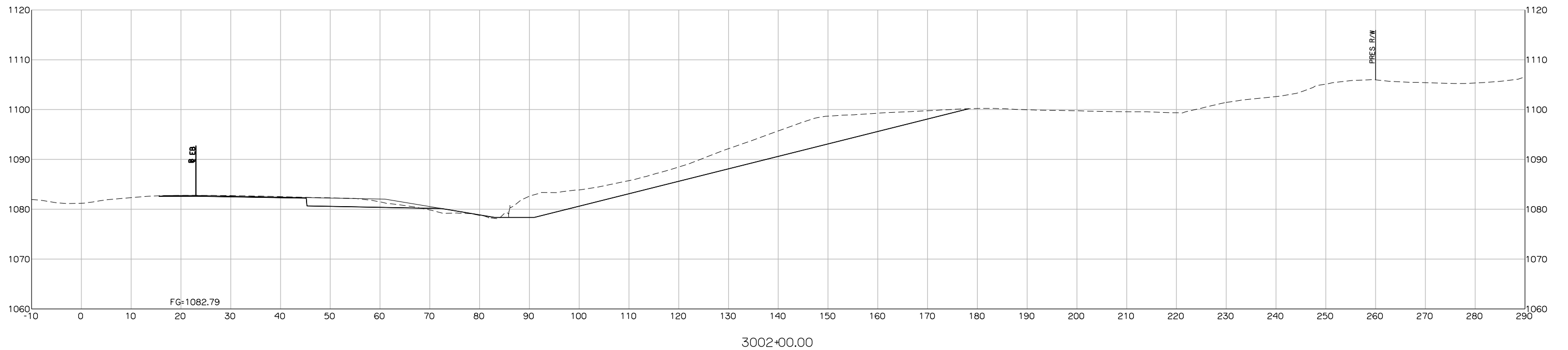
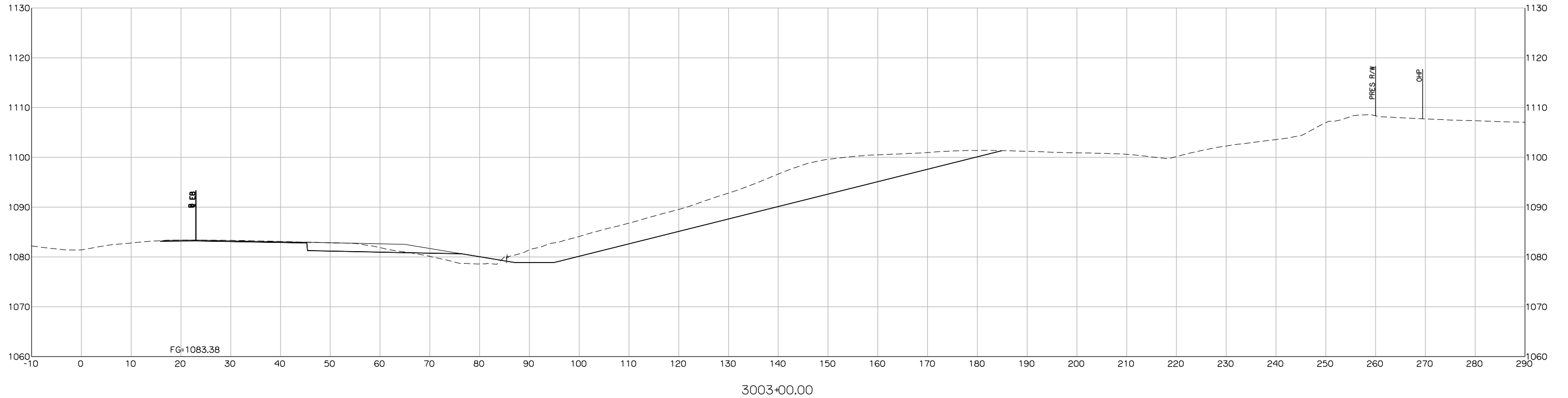

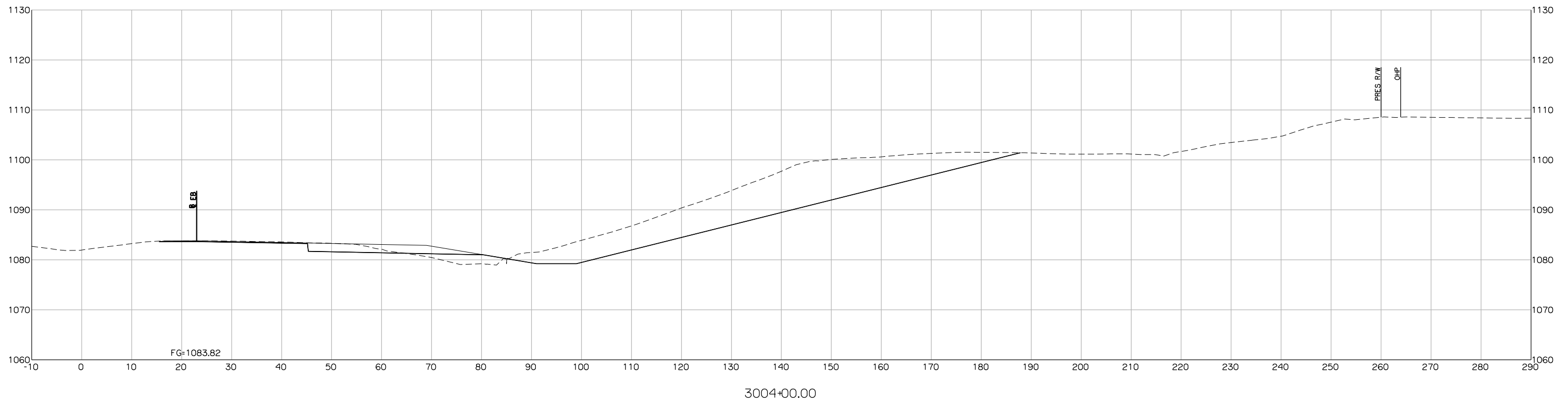
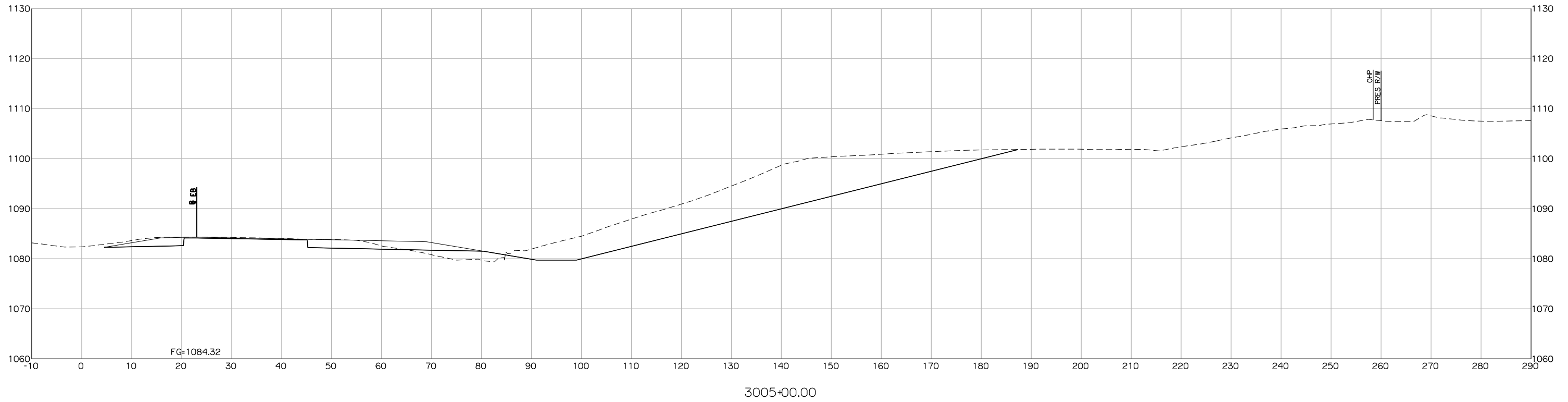

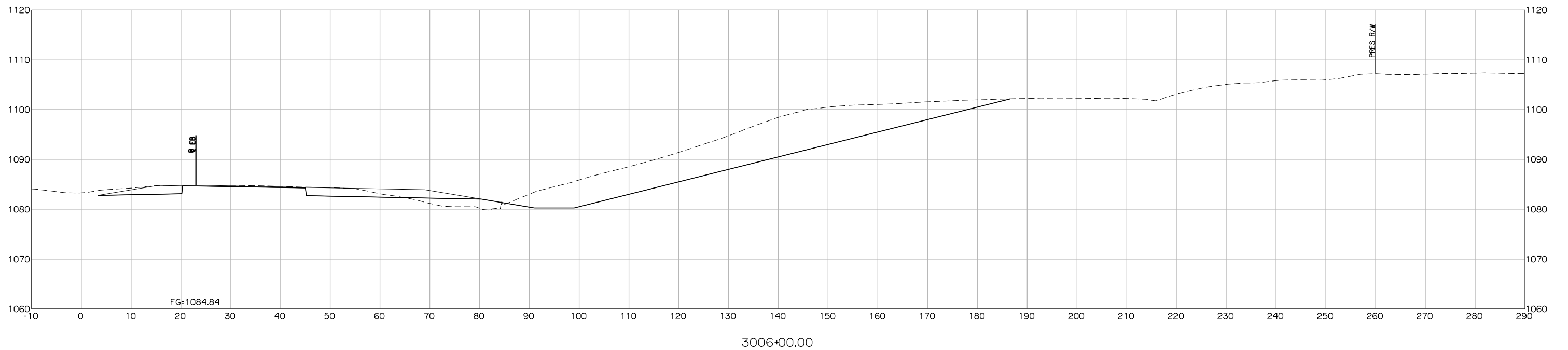
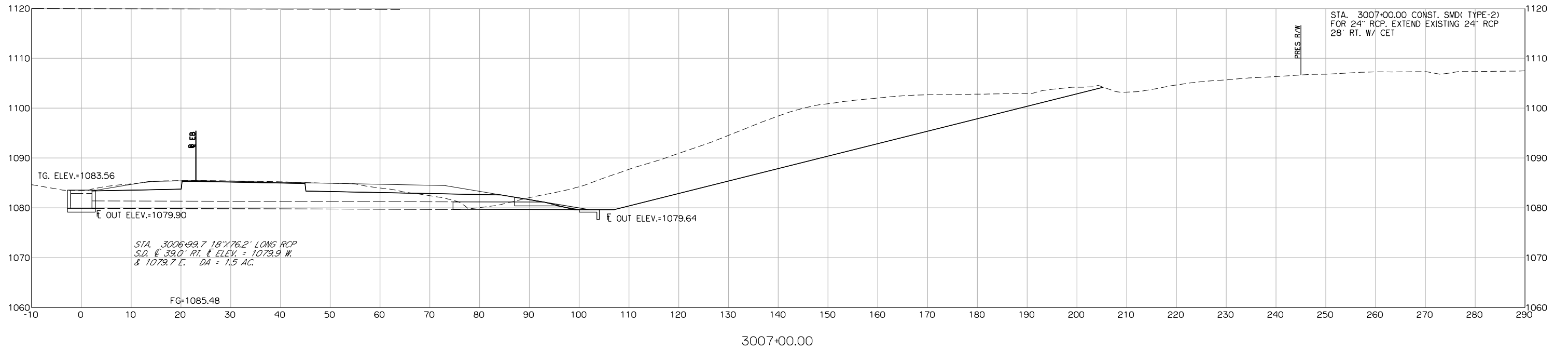

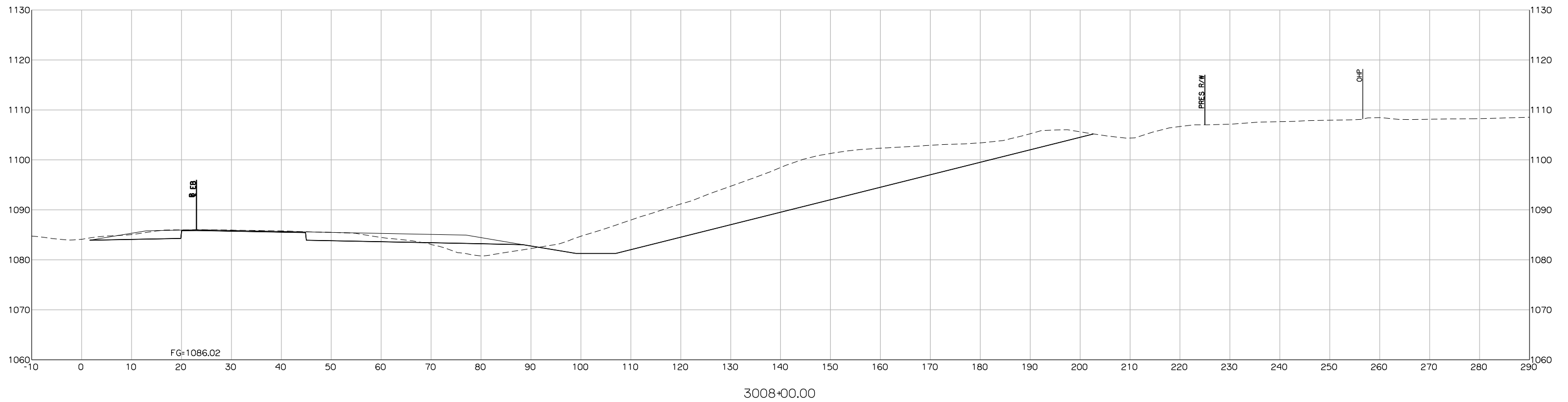
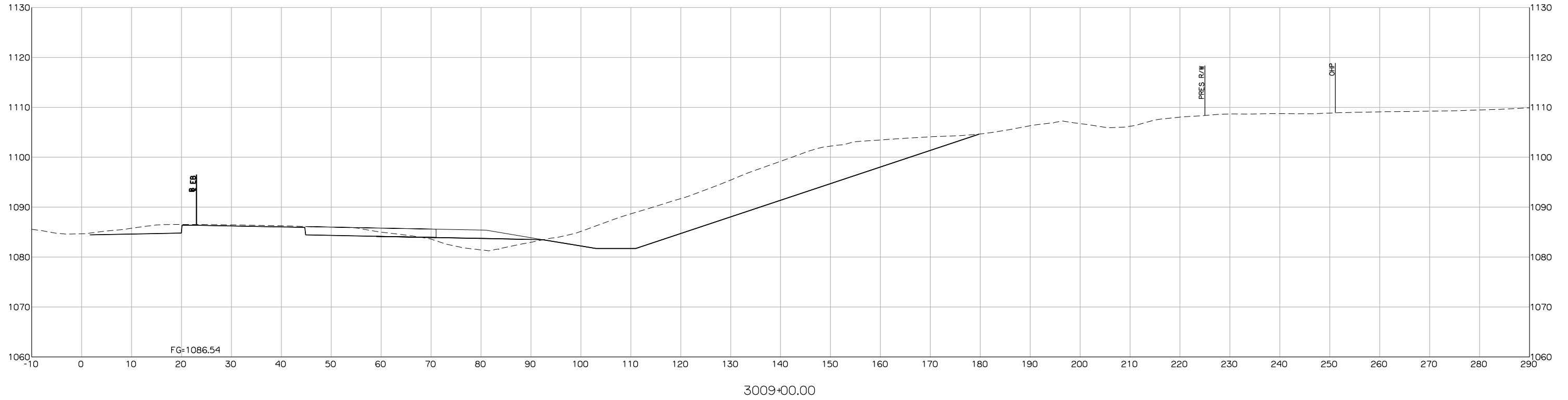

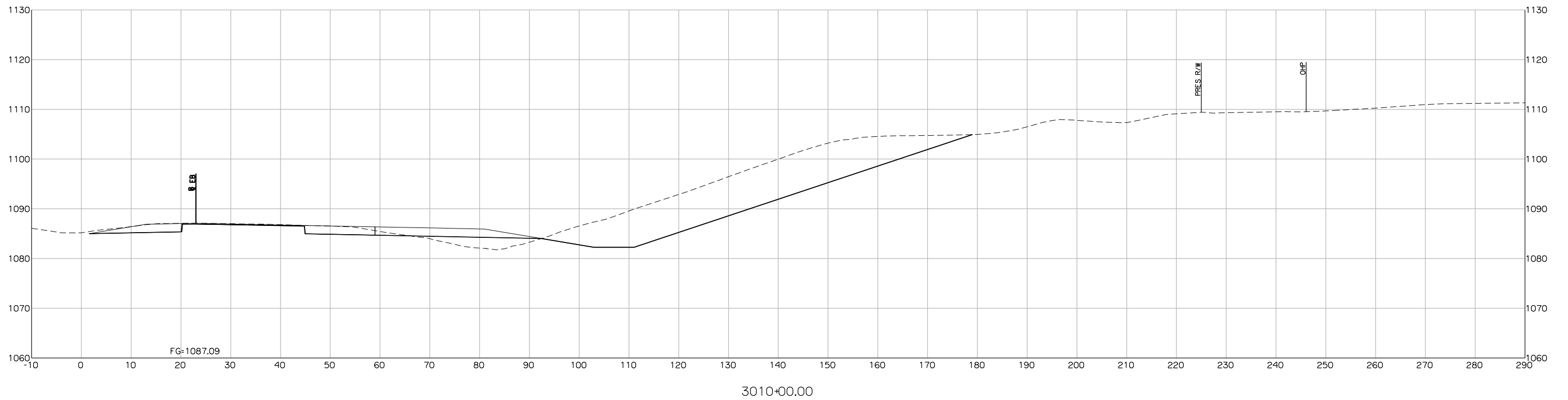
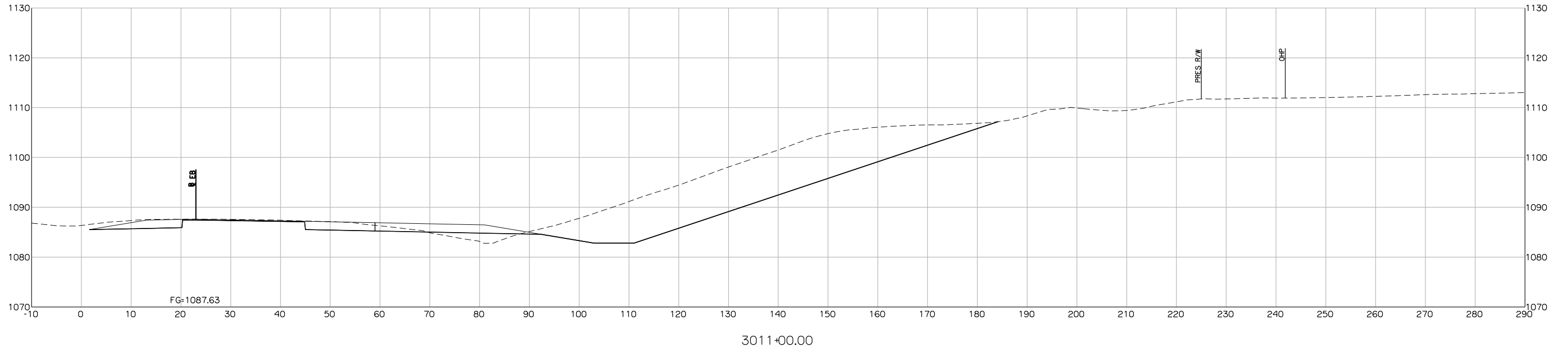

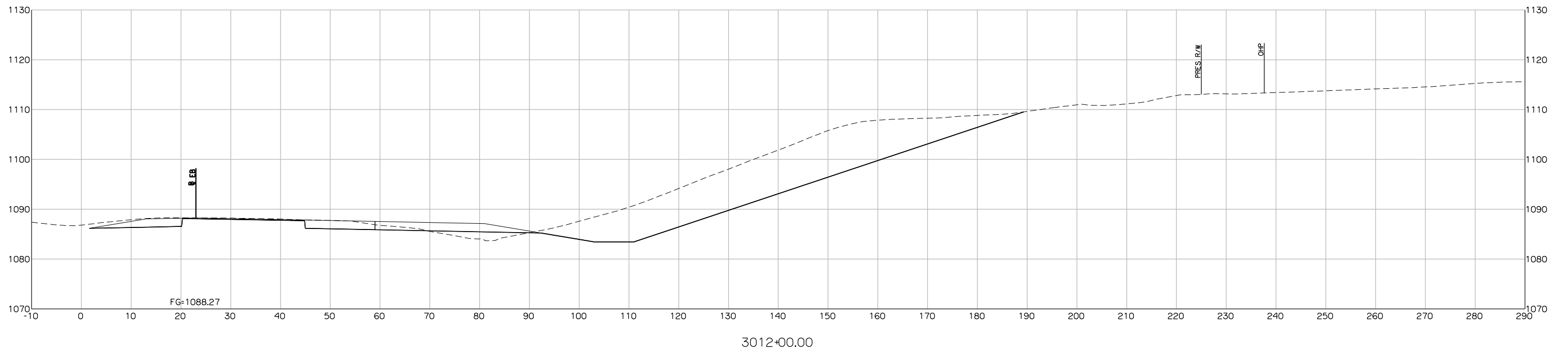
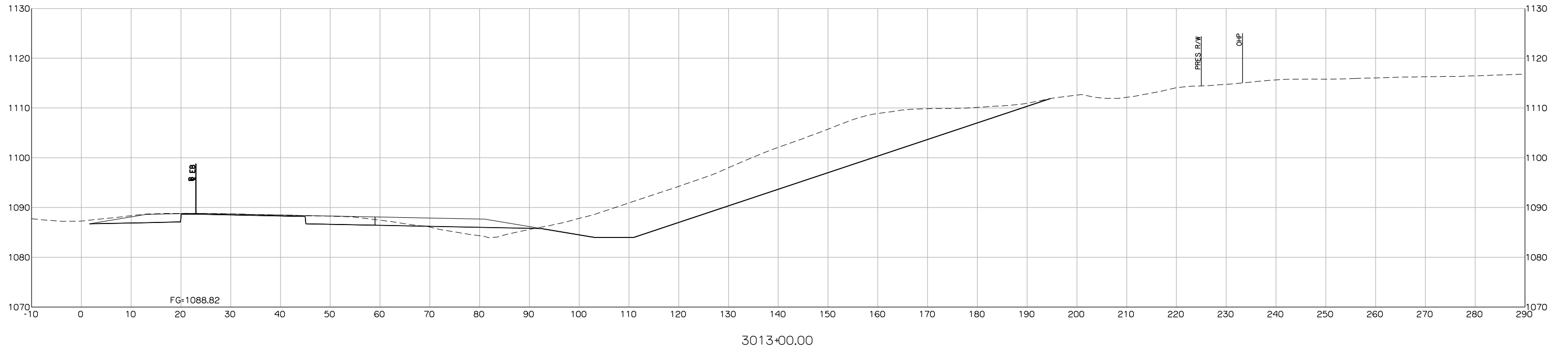

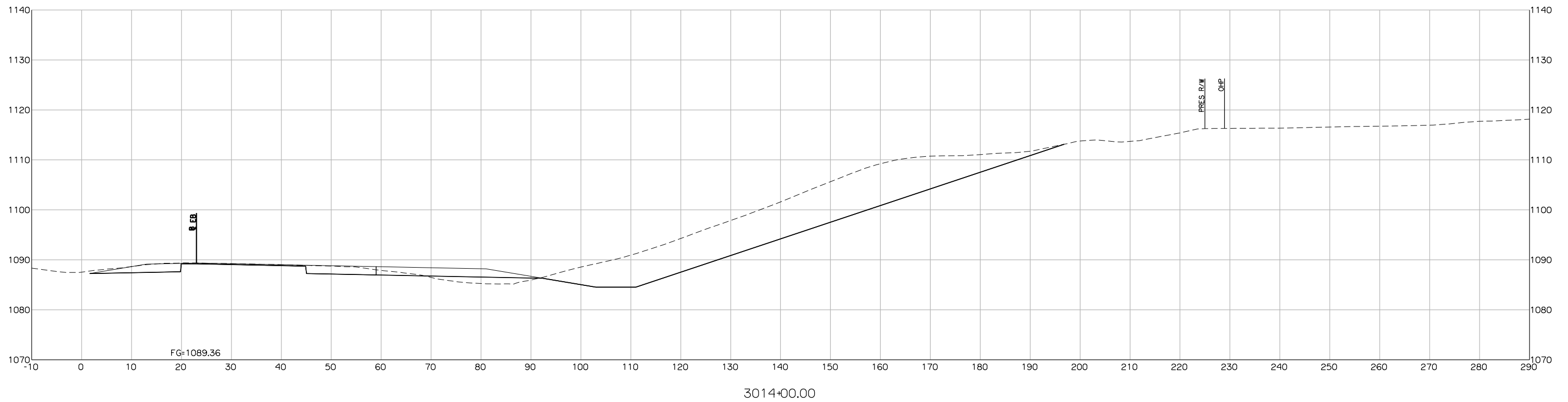
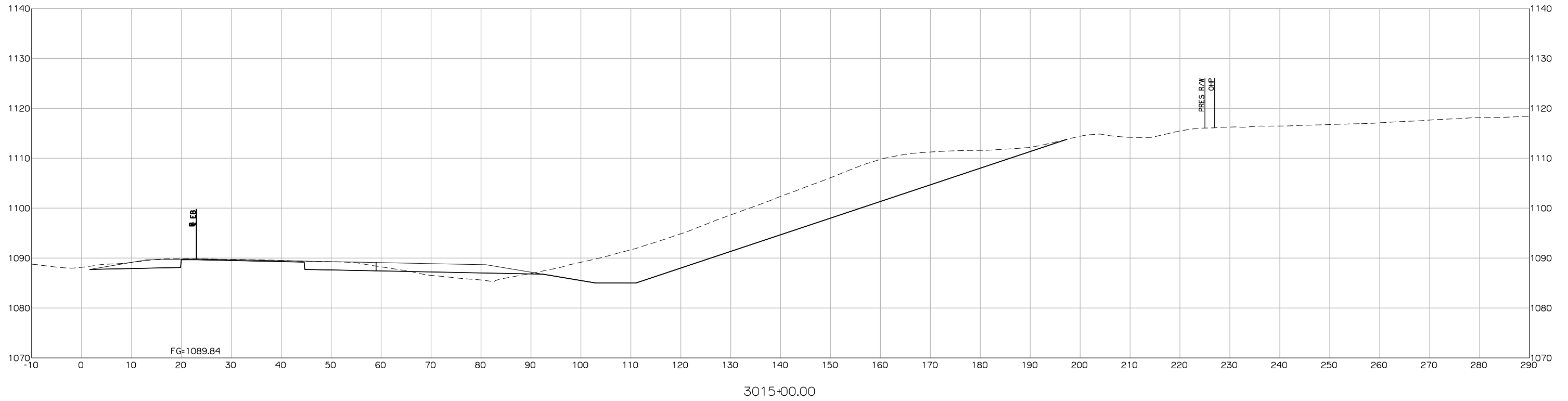

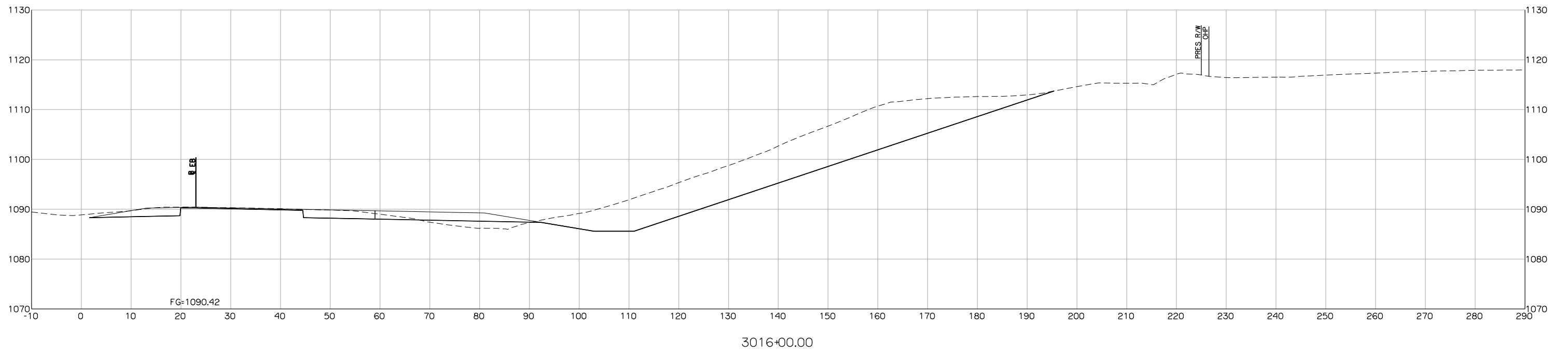
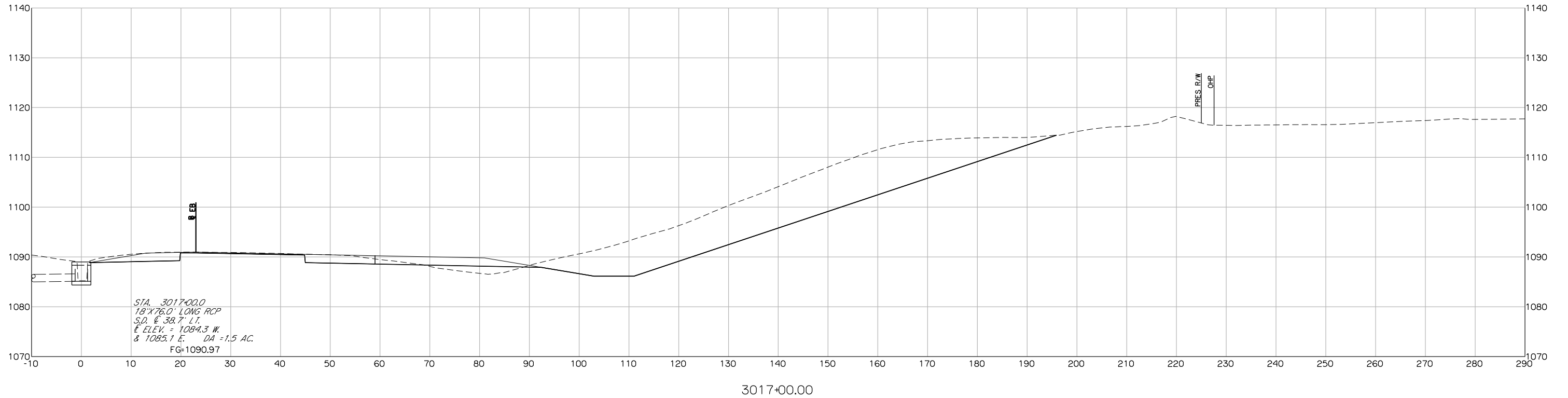

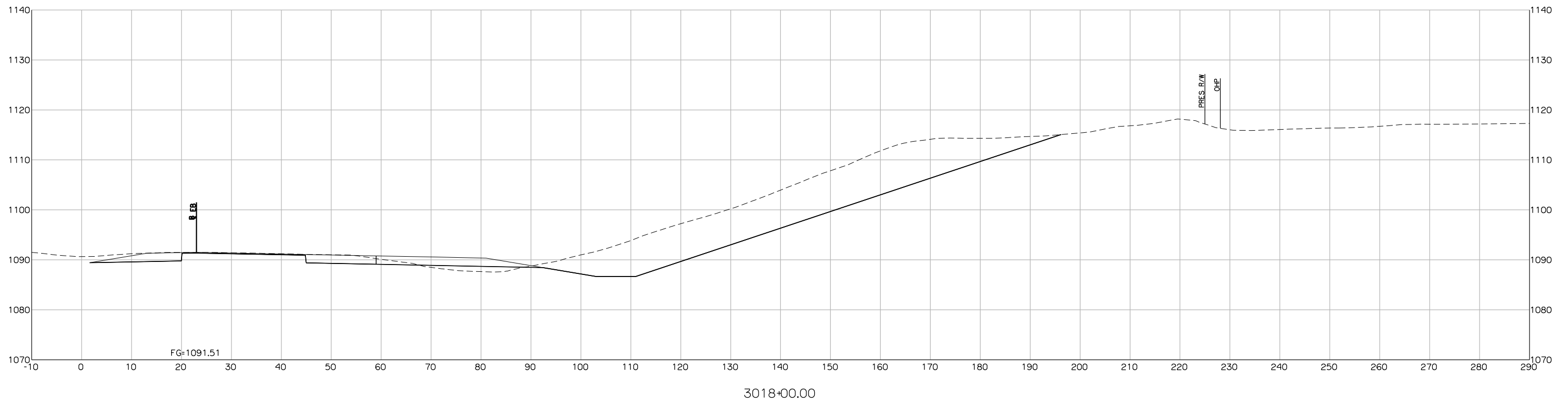
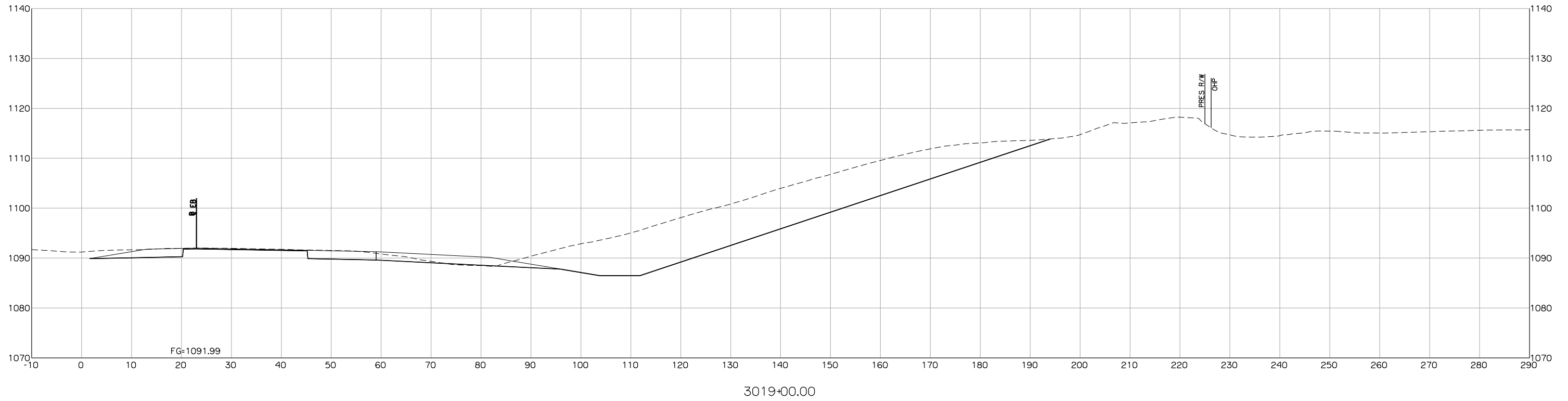

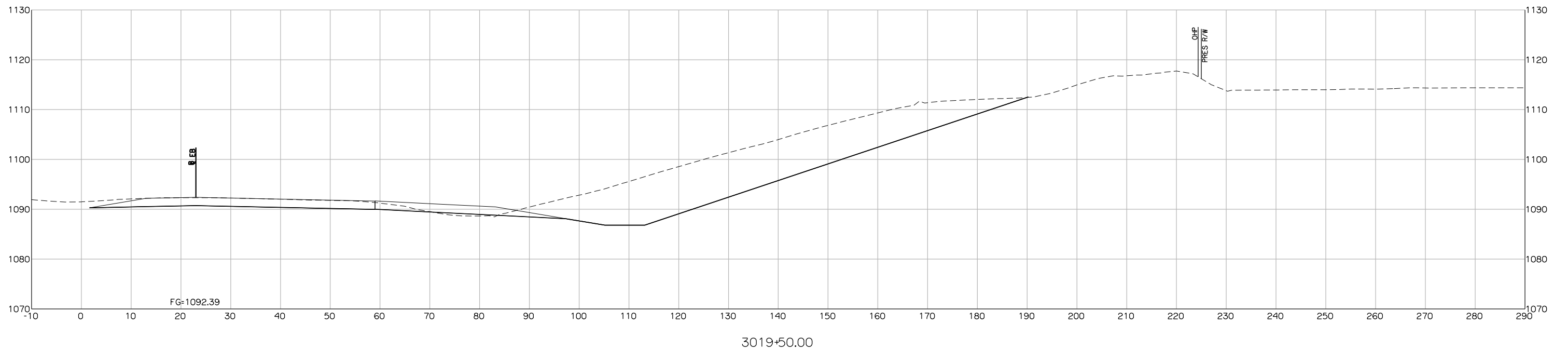
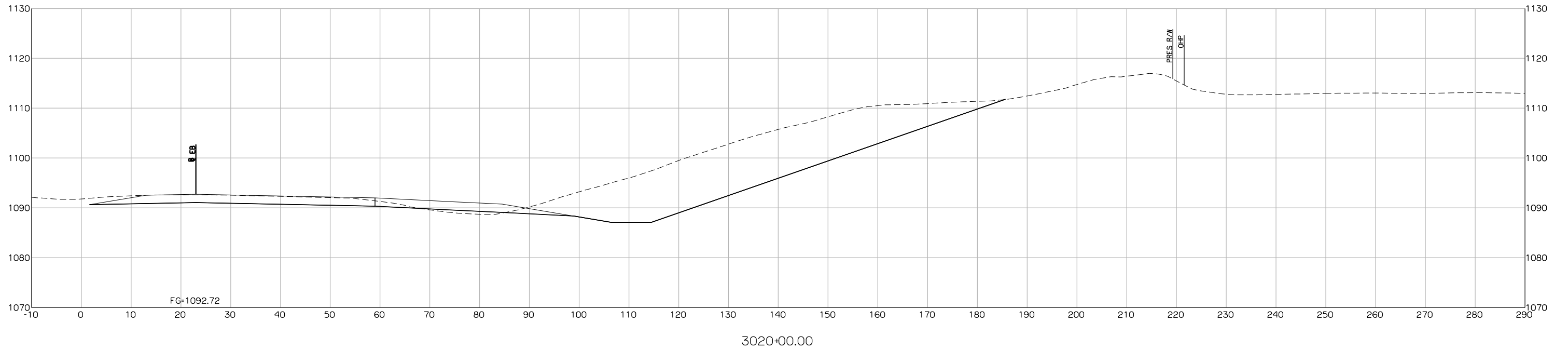

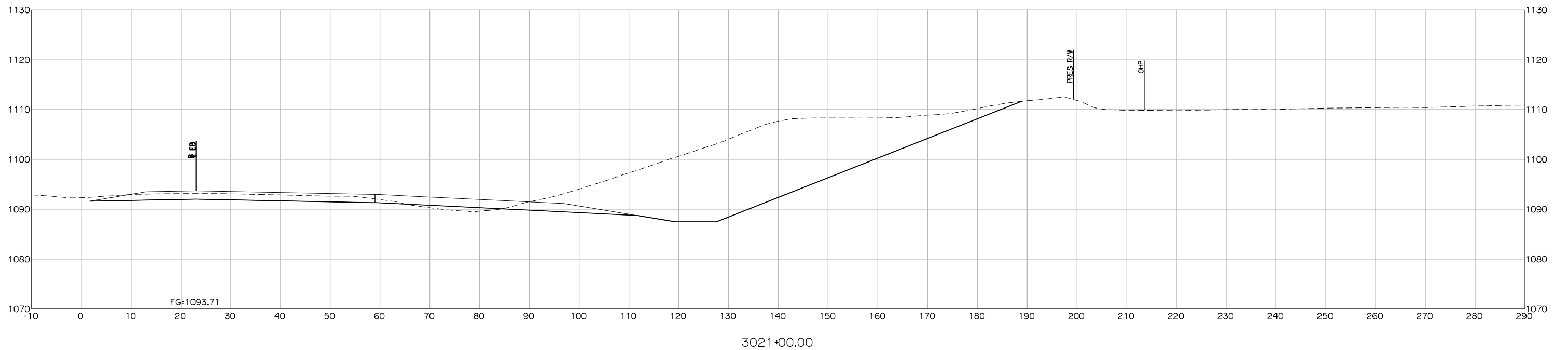
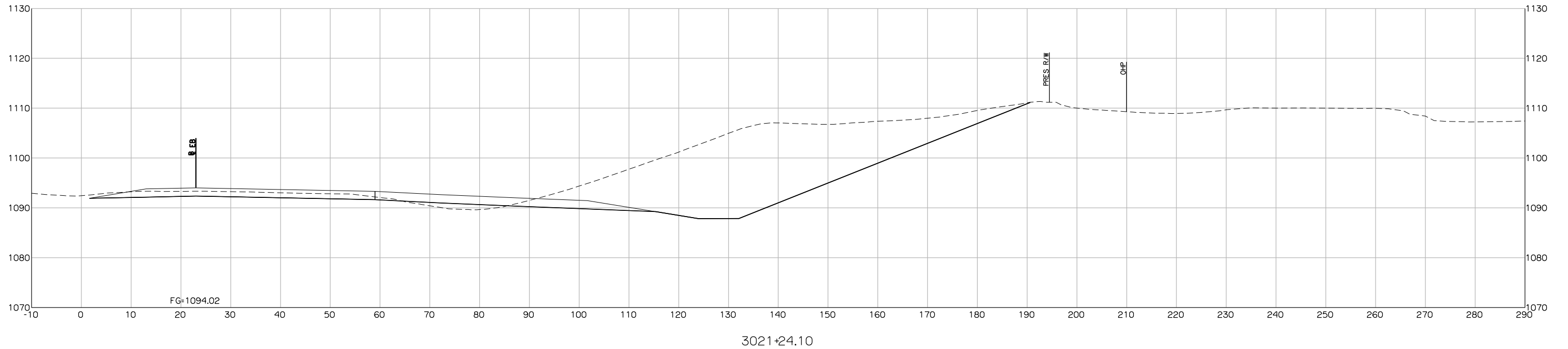

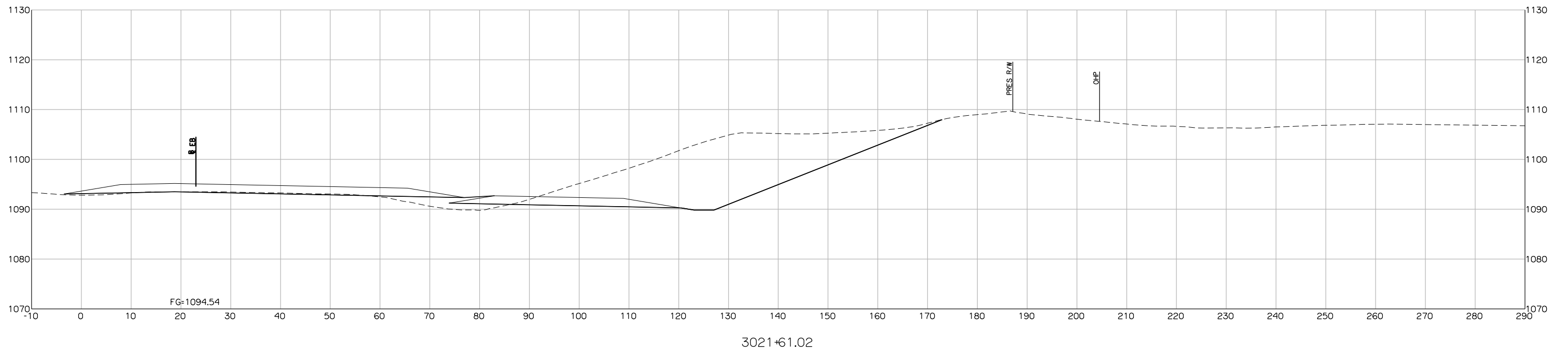
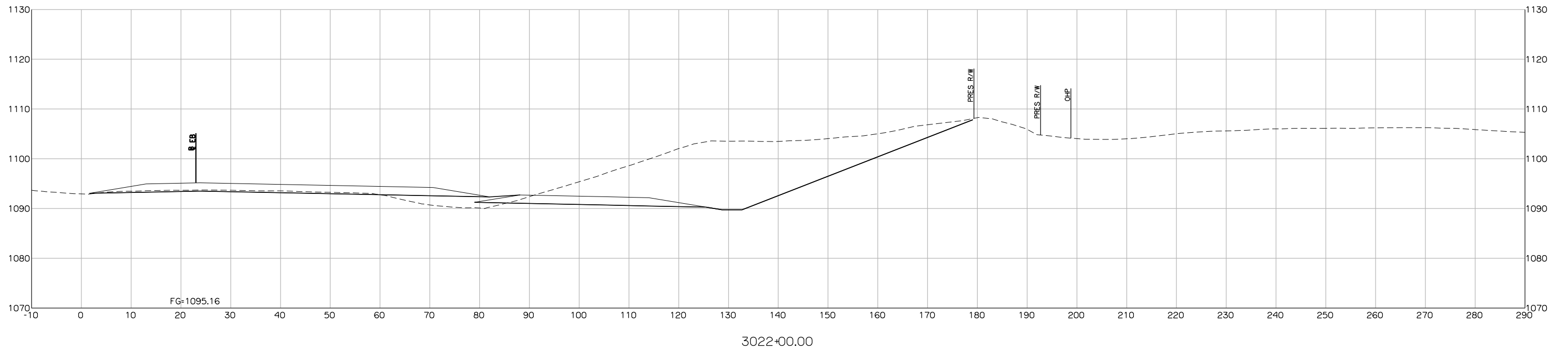

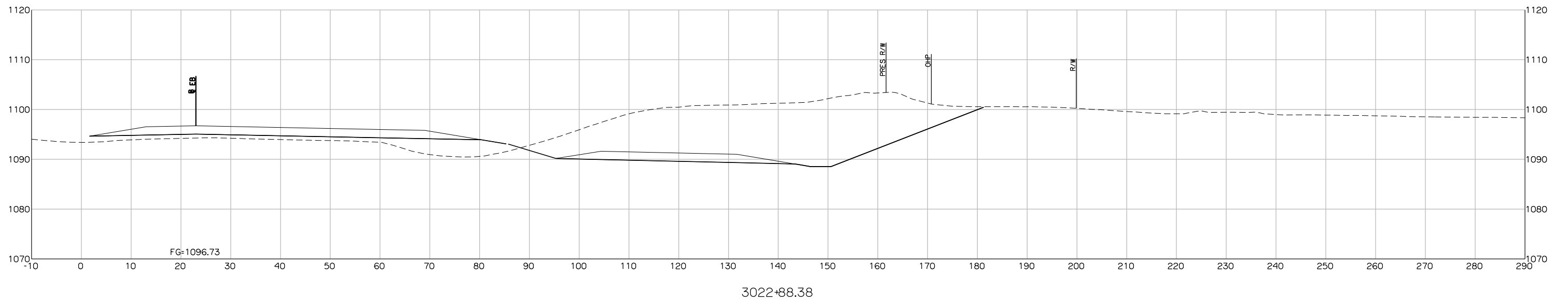
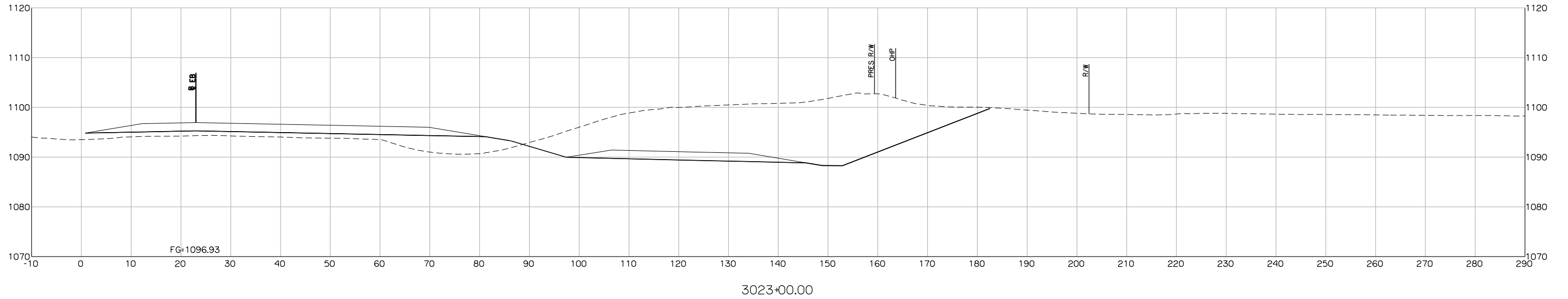

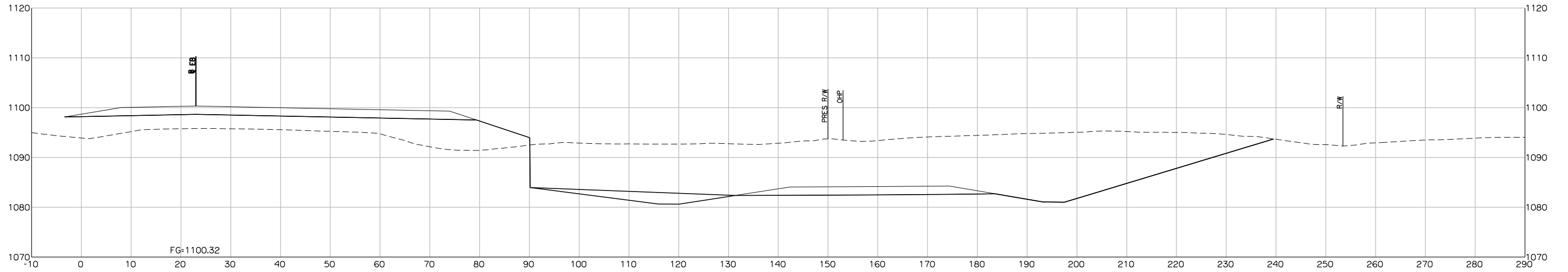

3025+00.00

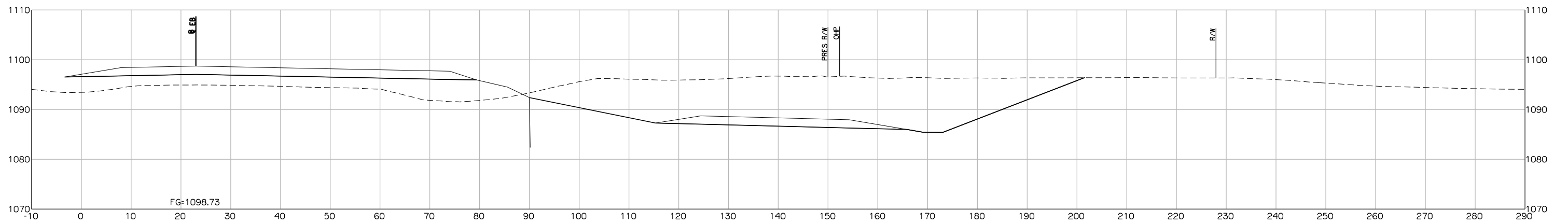

3024+00.00

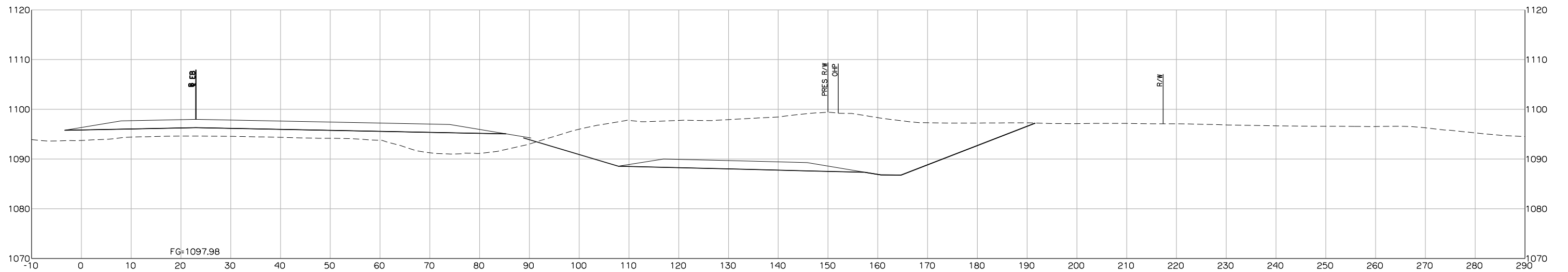

3023+58.38

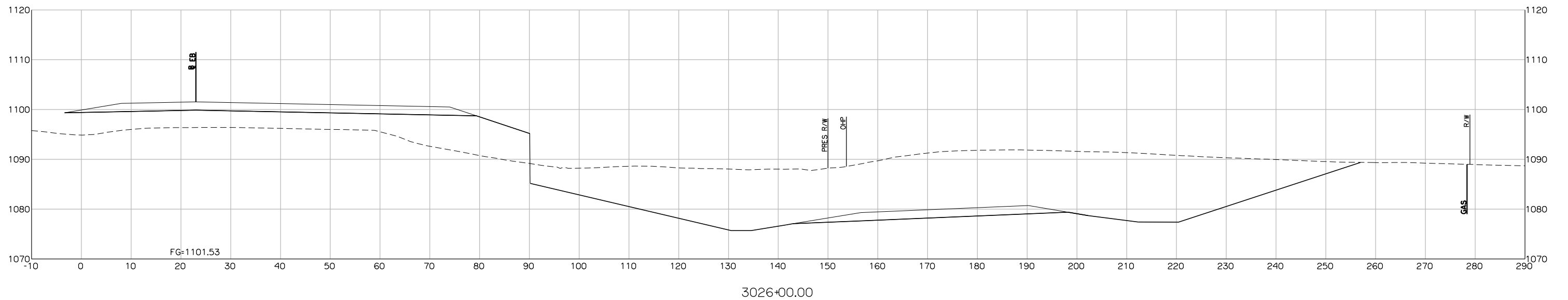
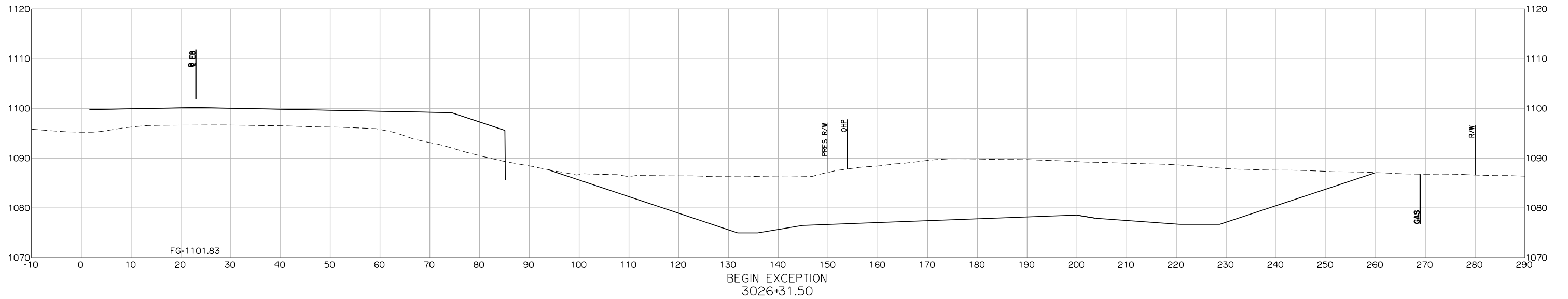

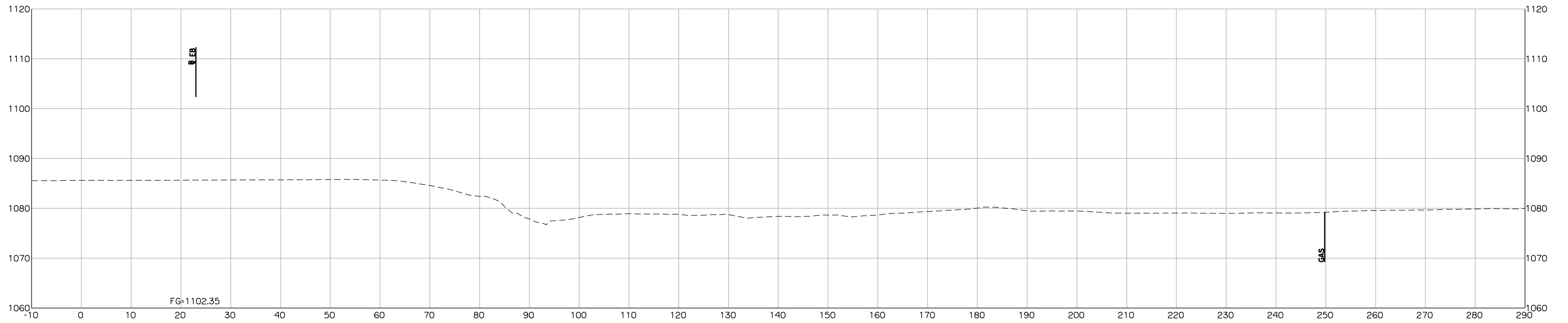

3027+00.00

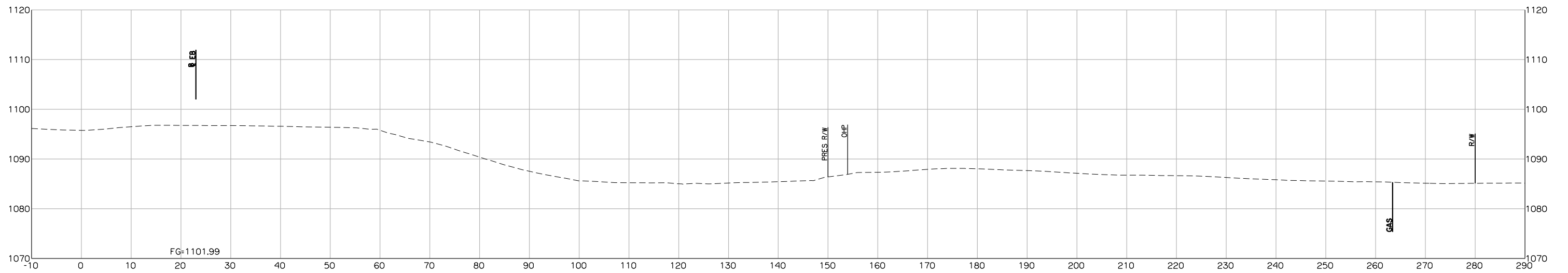

3026+50.00

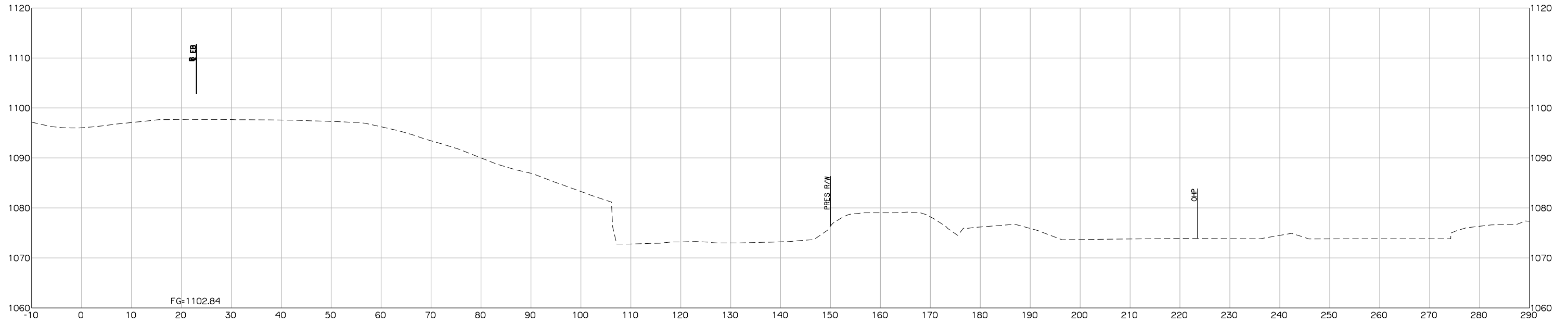

3028+75.00

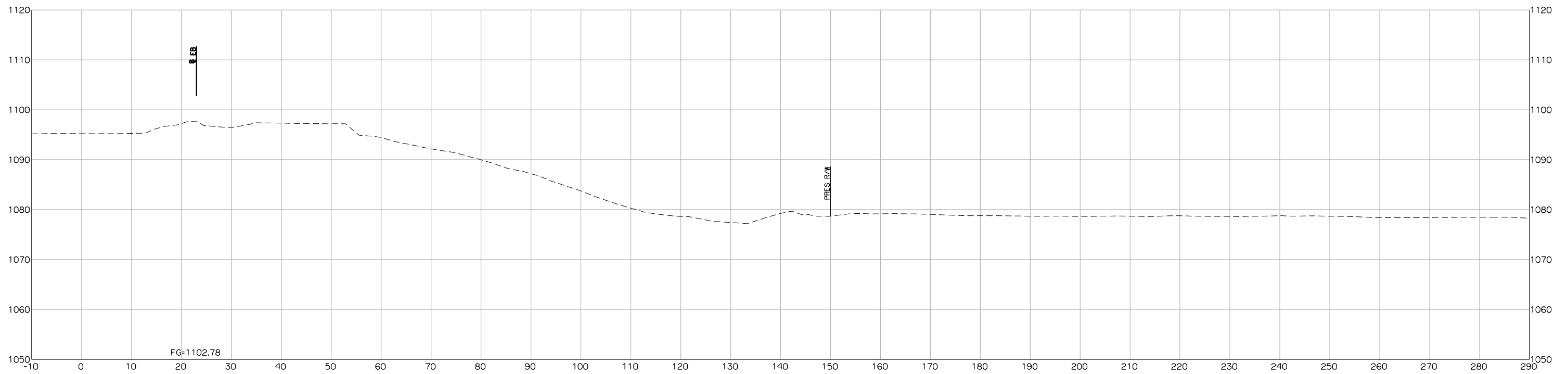

3028+00.00

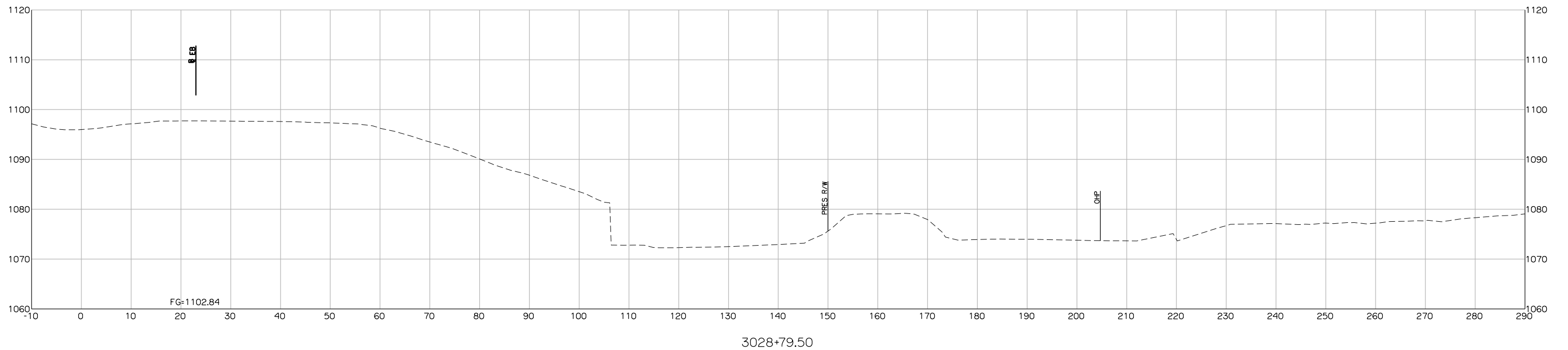
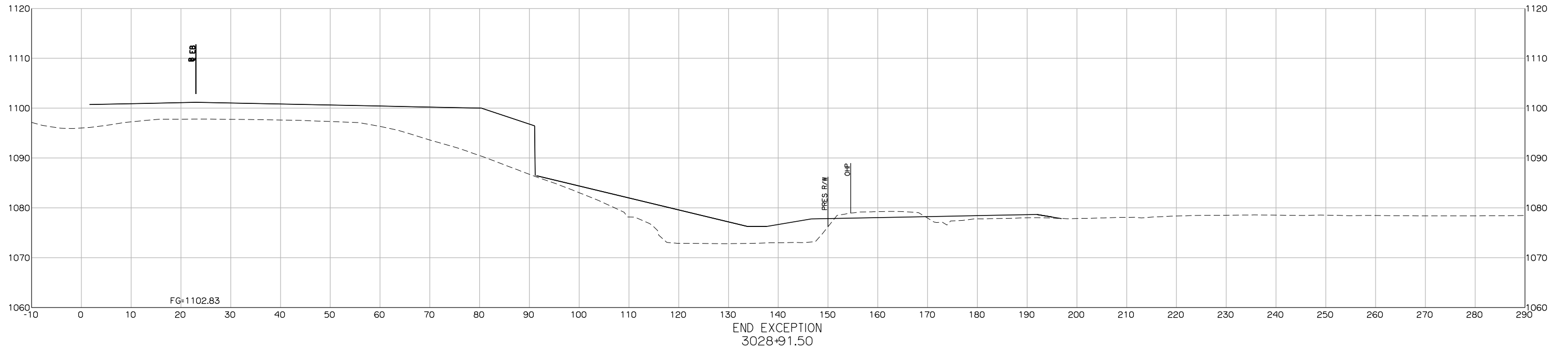

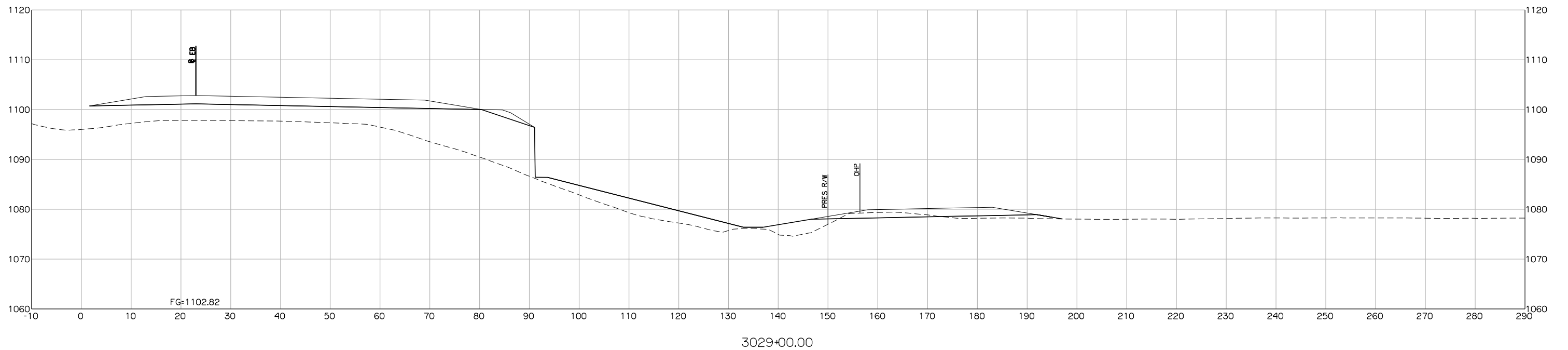
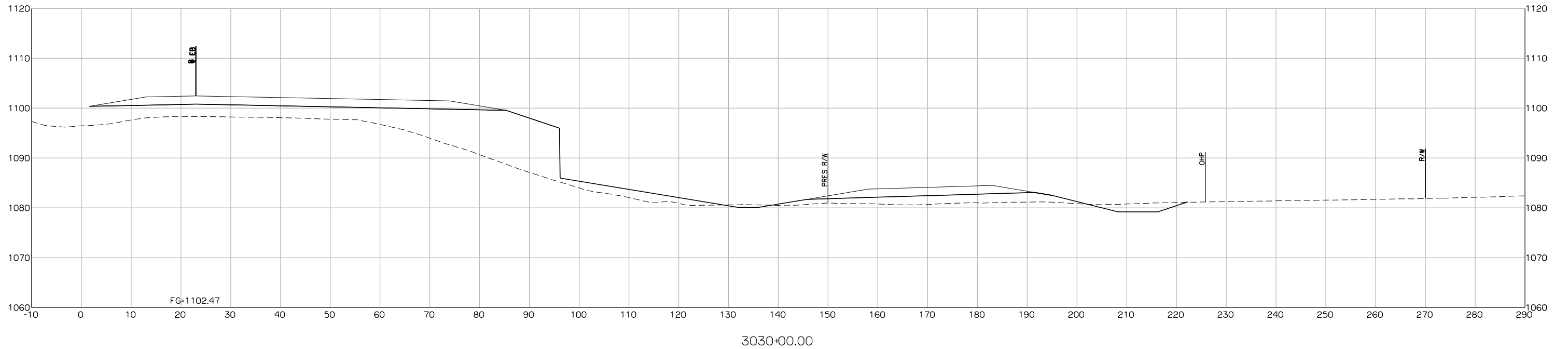

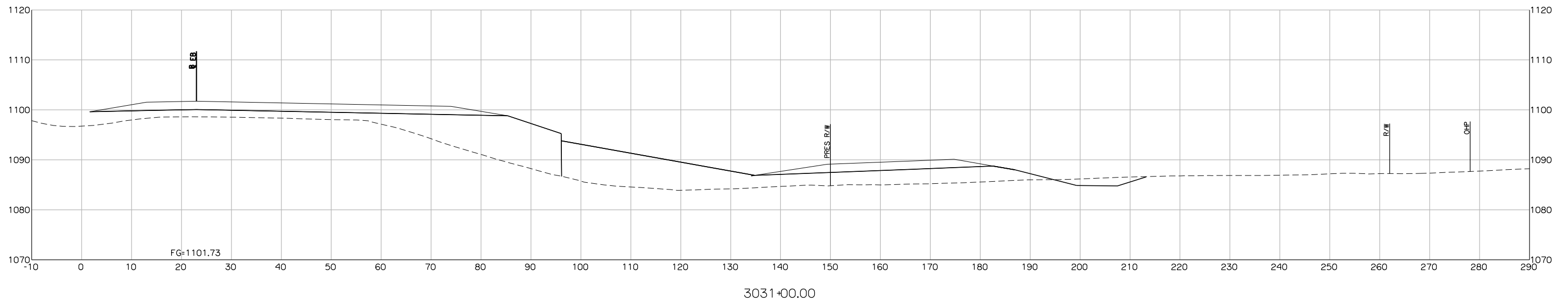
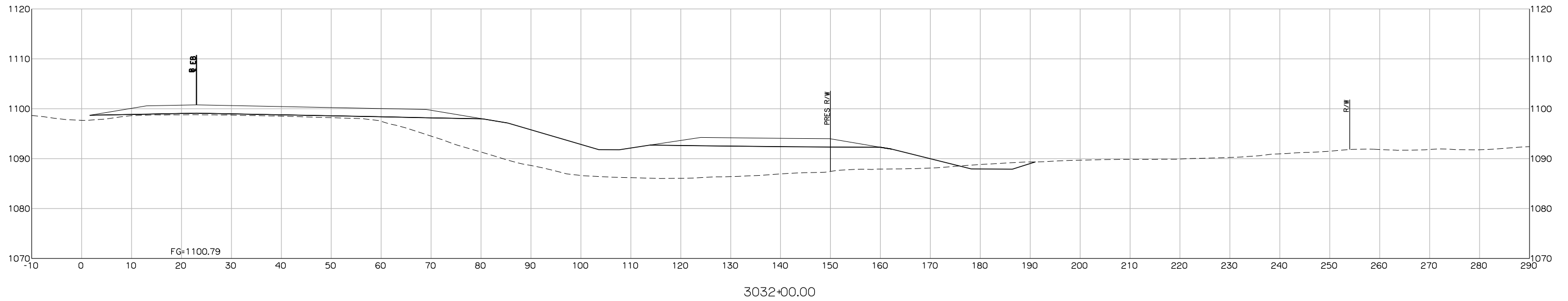

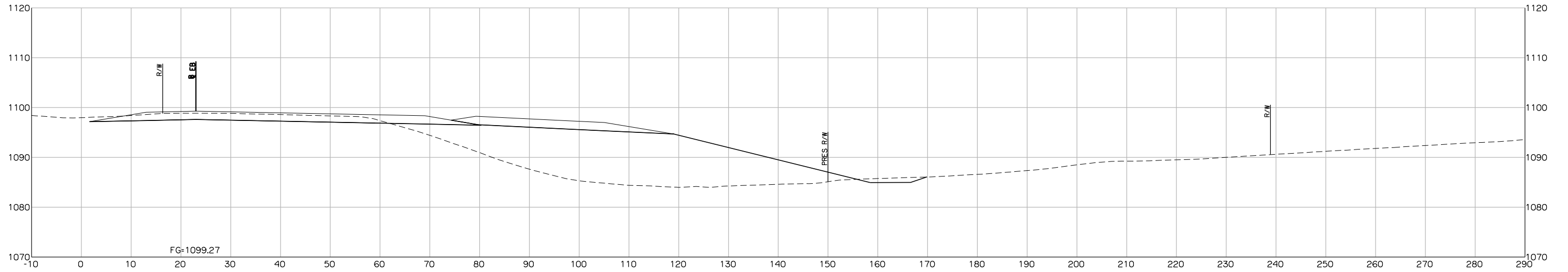

3033+88.86

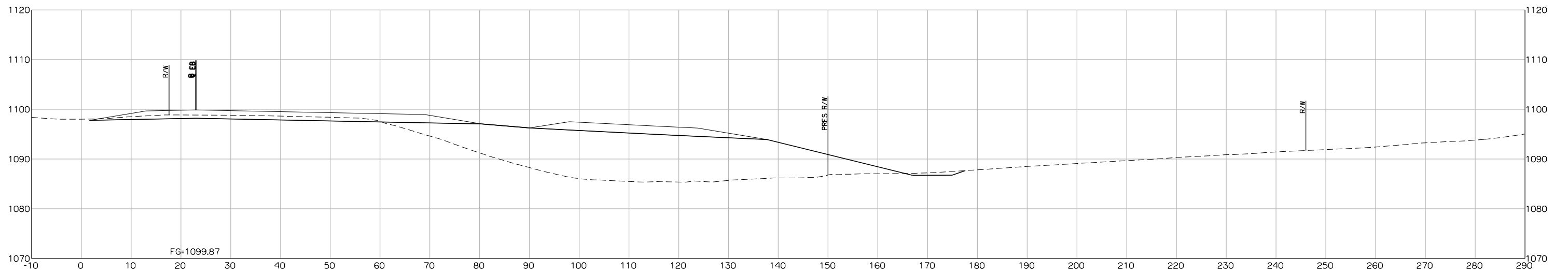

3033+00.00

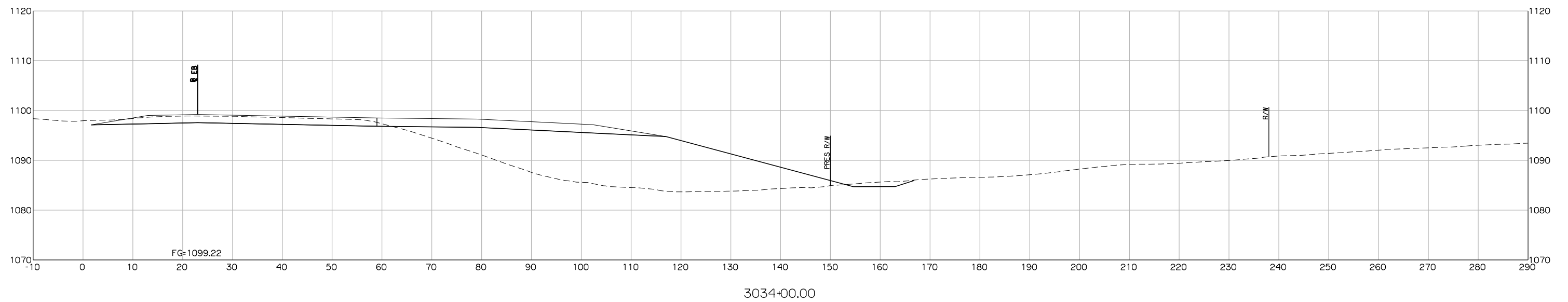
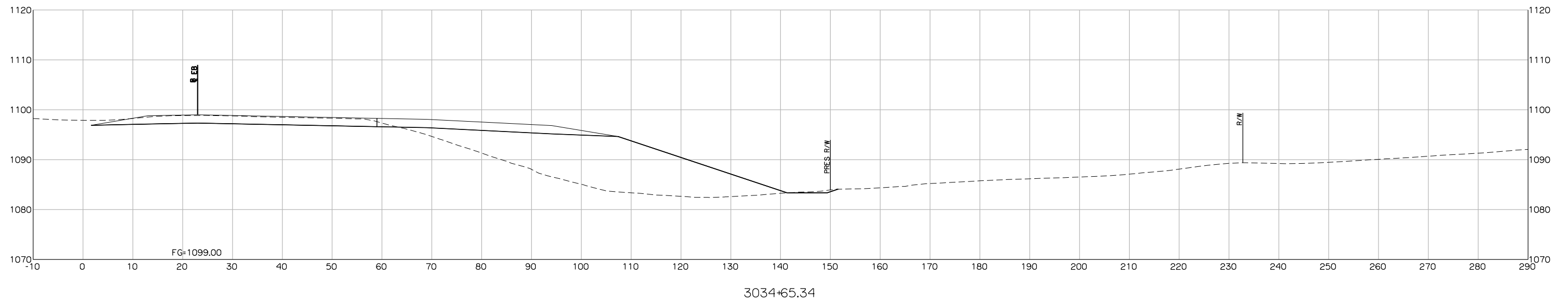

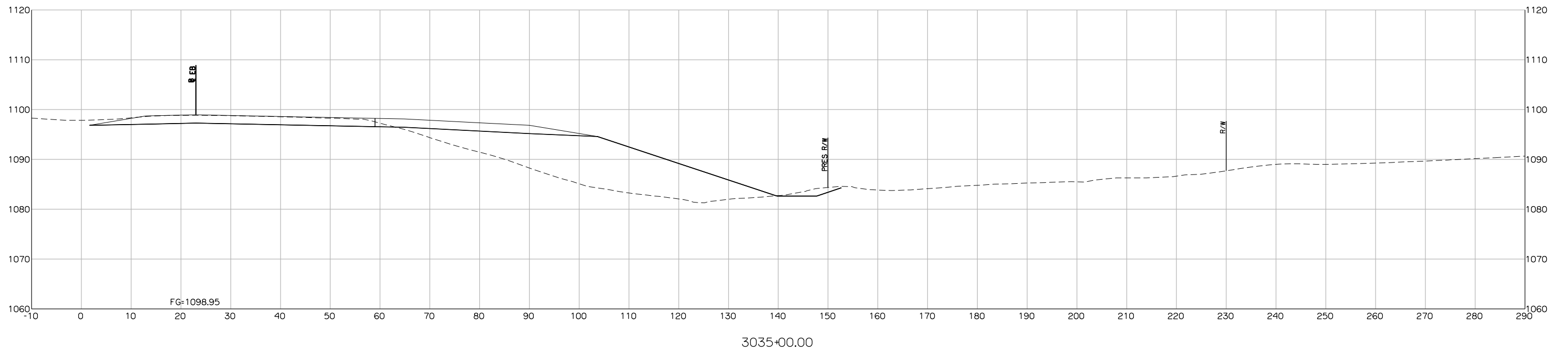
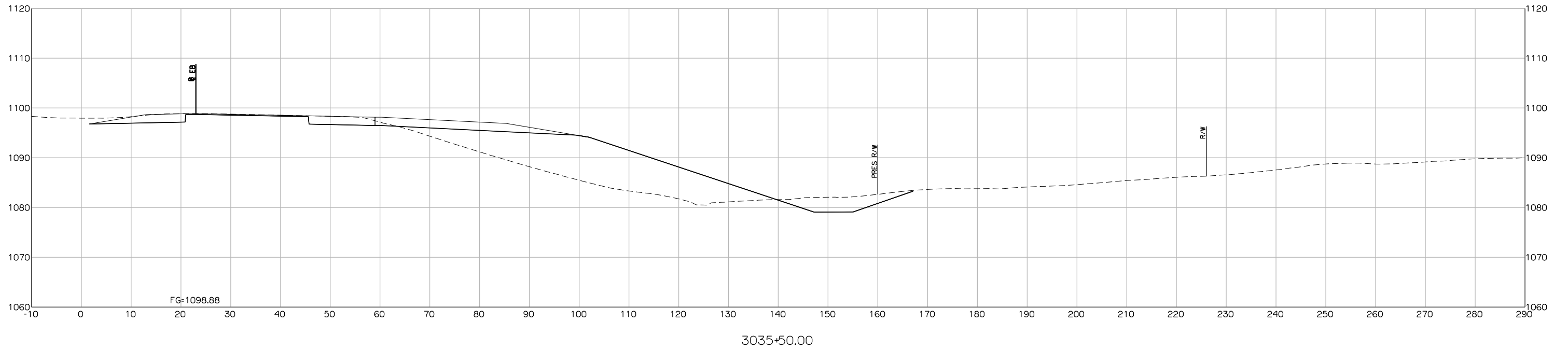

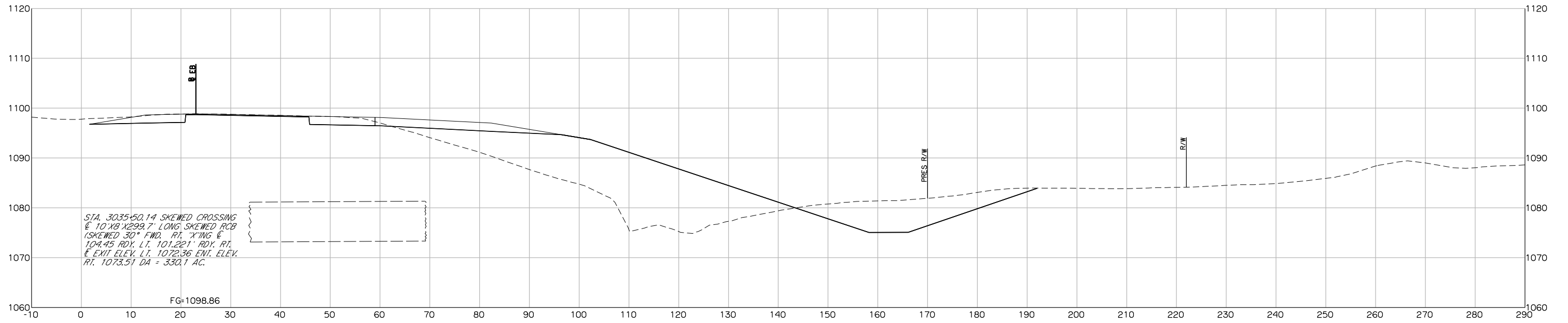

3036+00.00

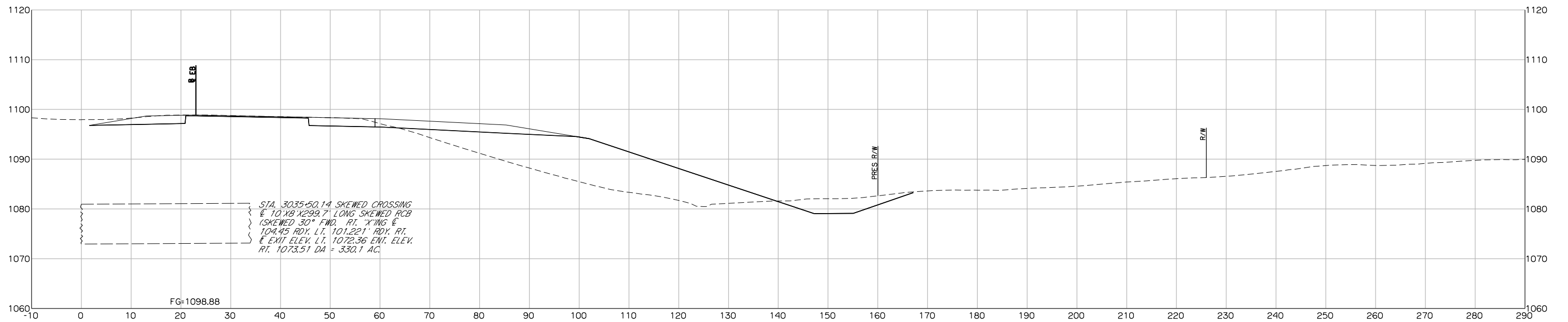

3035+50.14

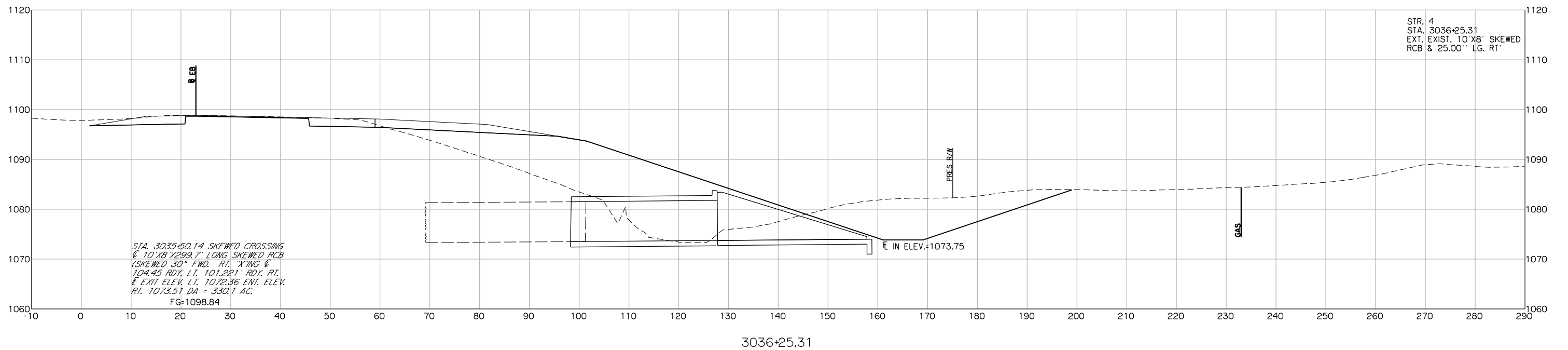
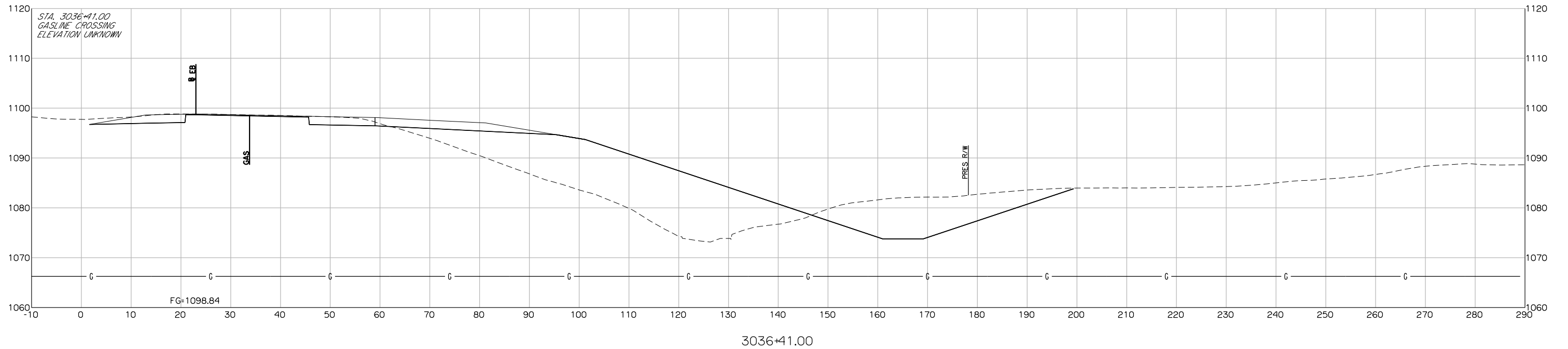

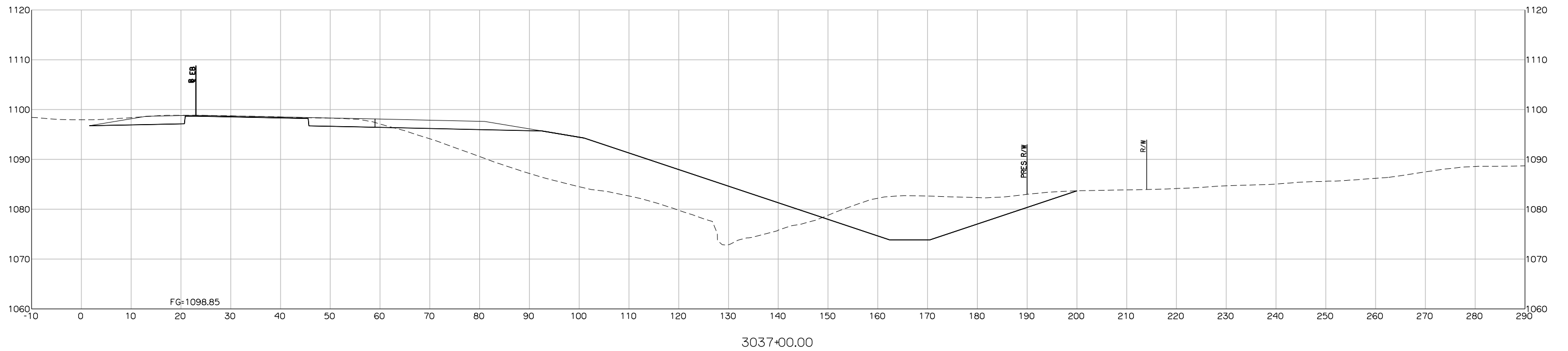
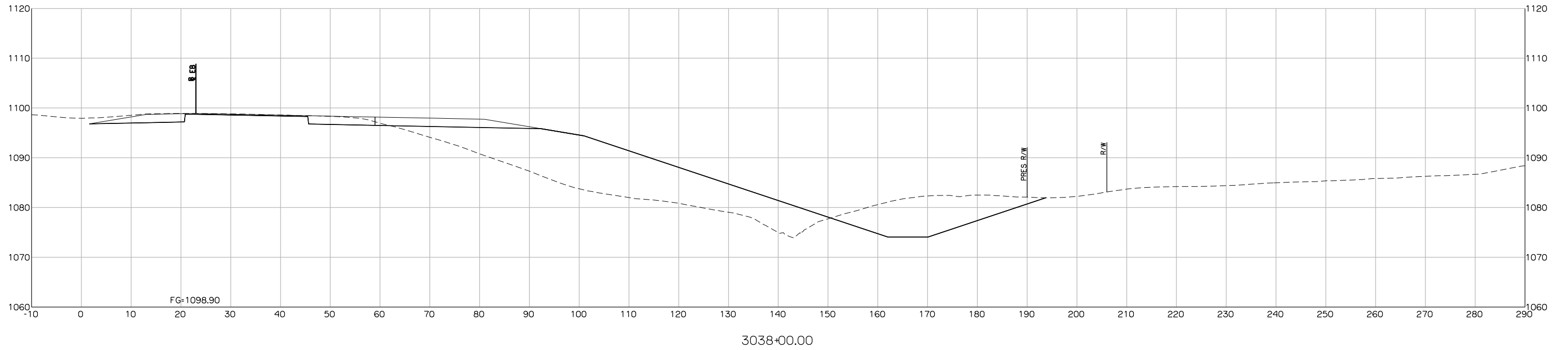

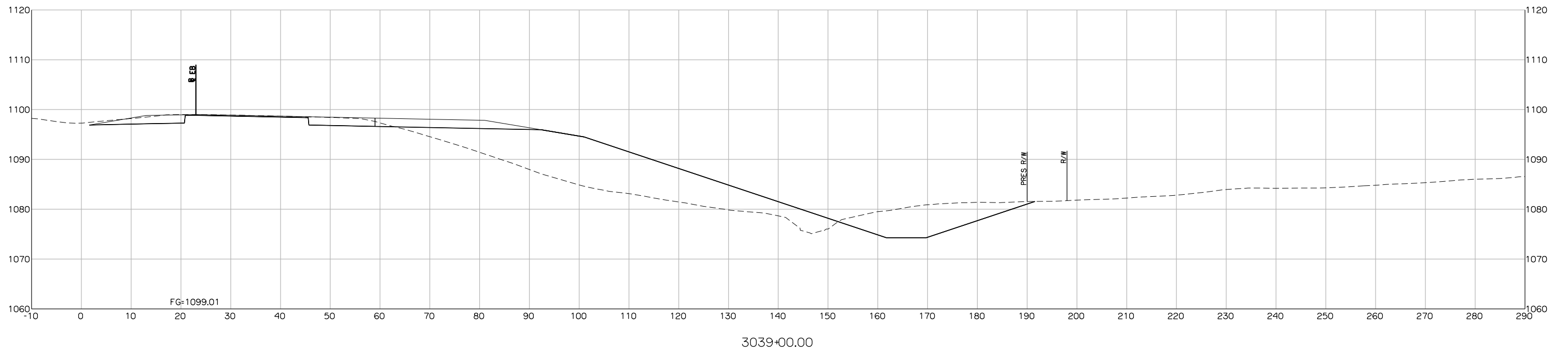
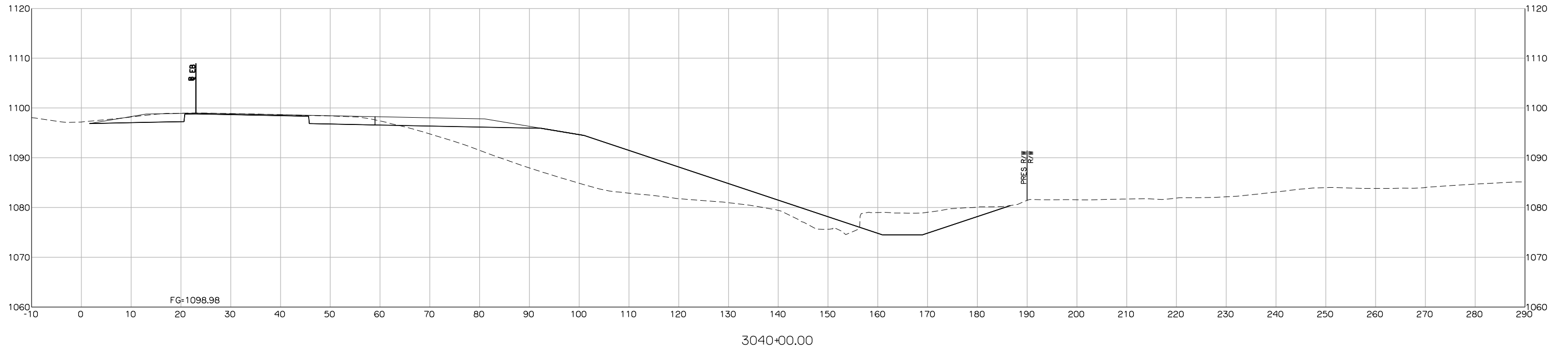

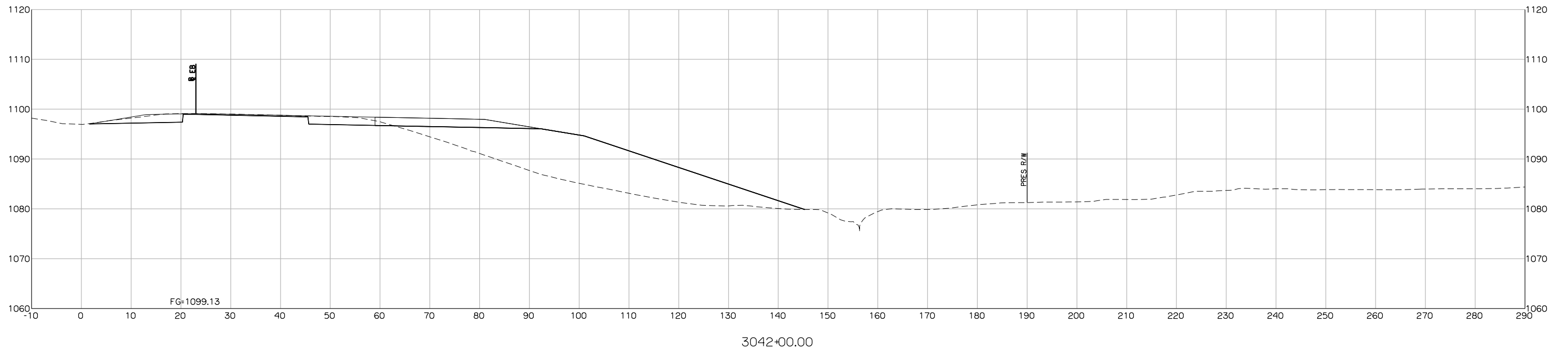

3042+00.00

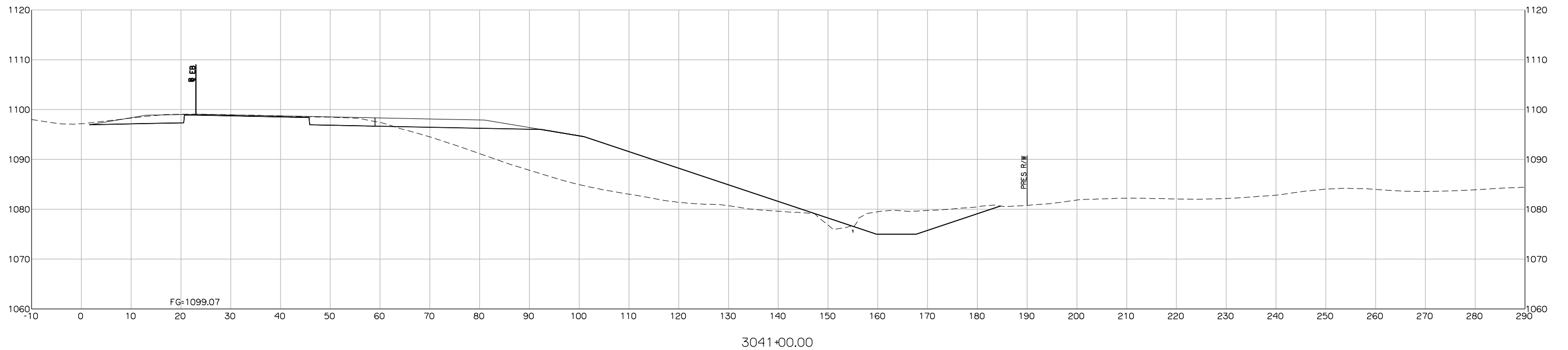

3041+00.00

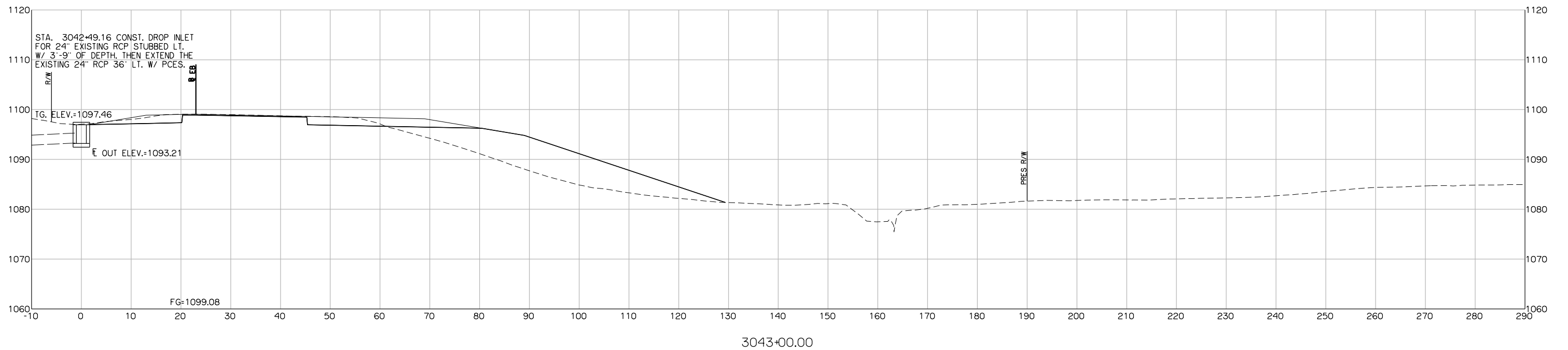
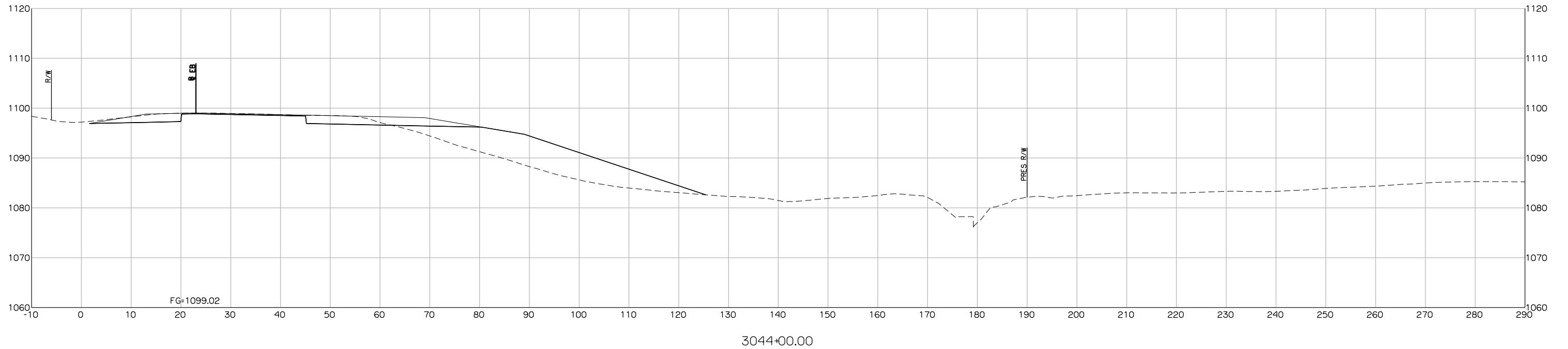

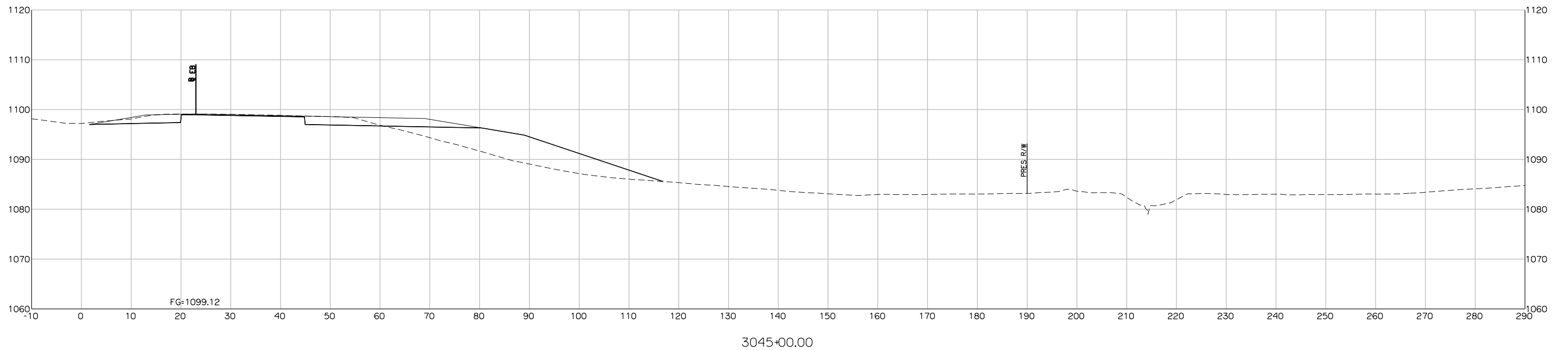
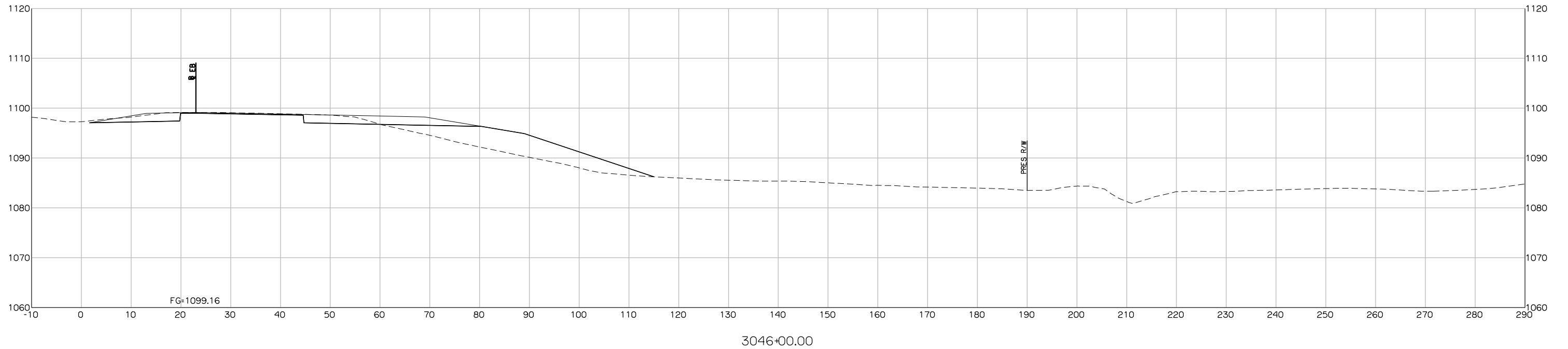

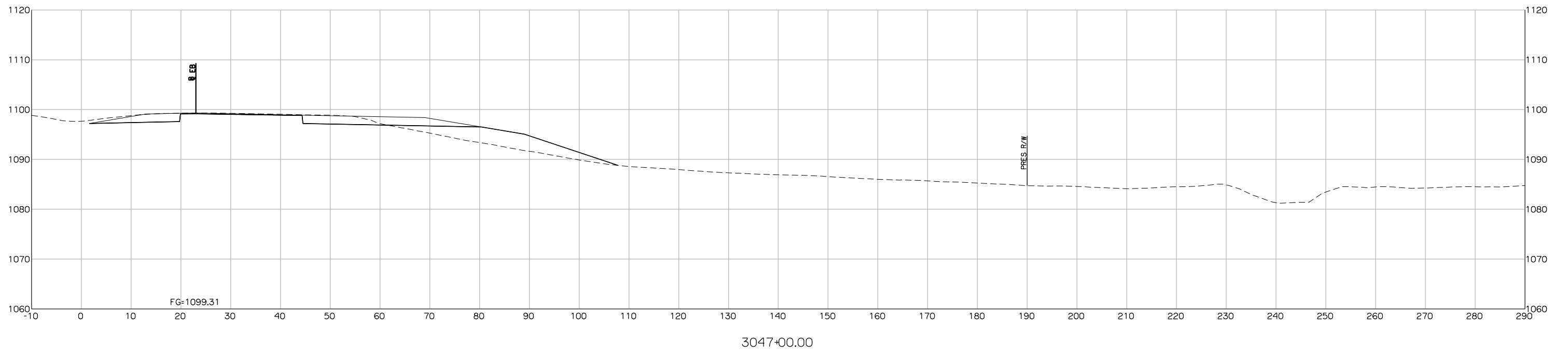
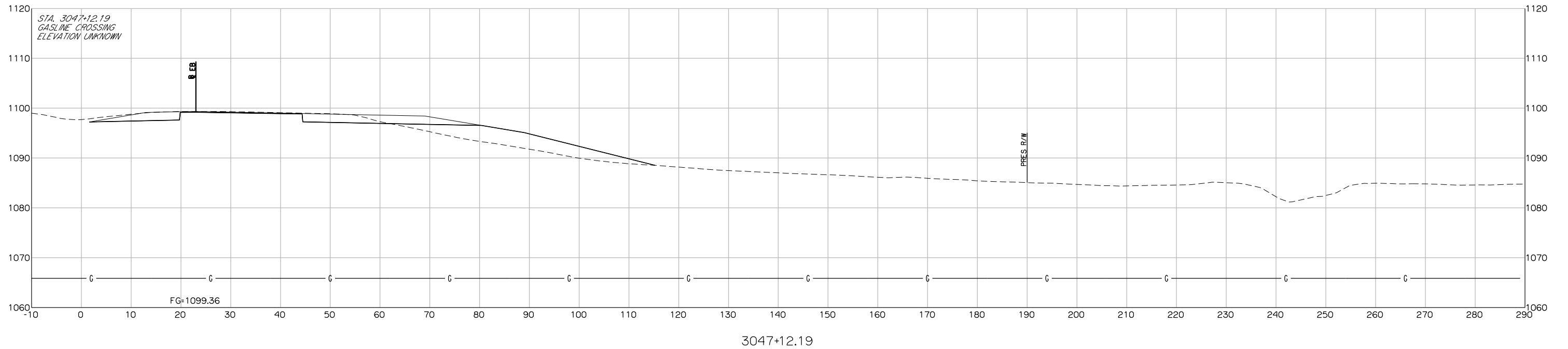

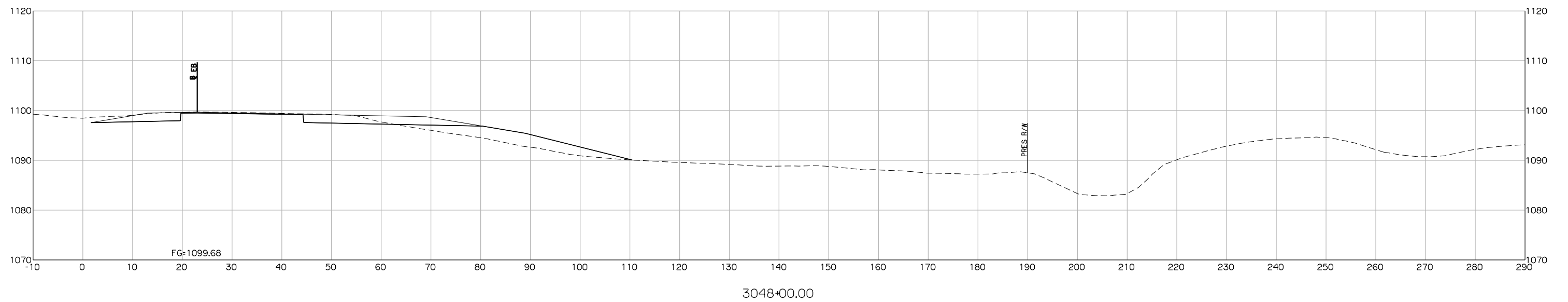
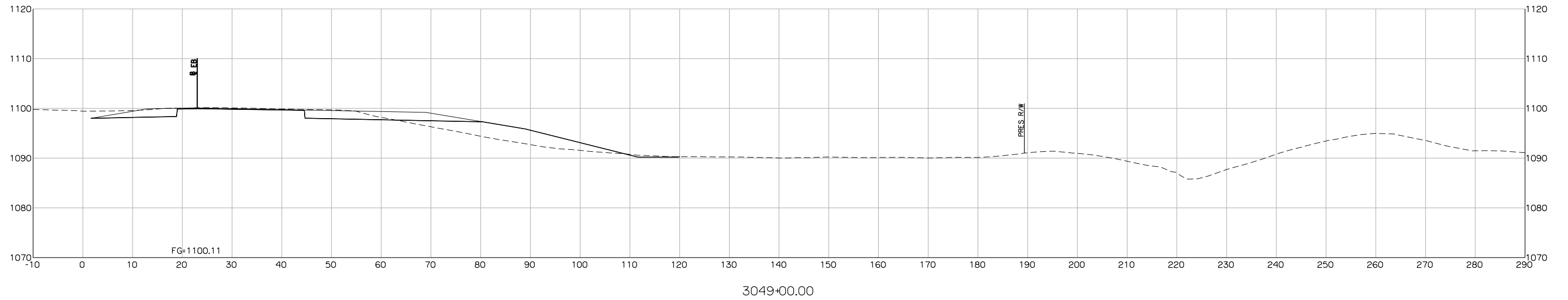

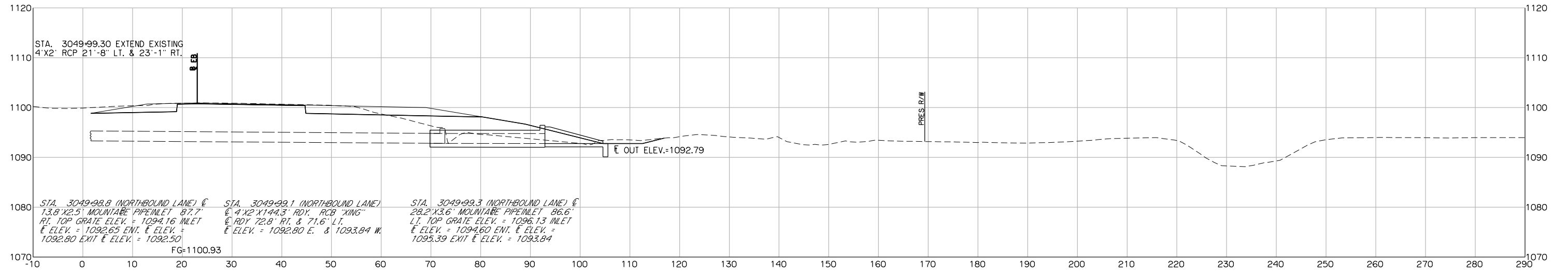

3050+00.00

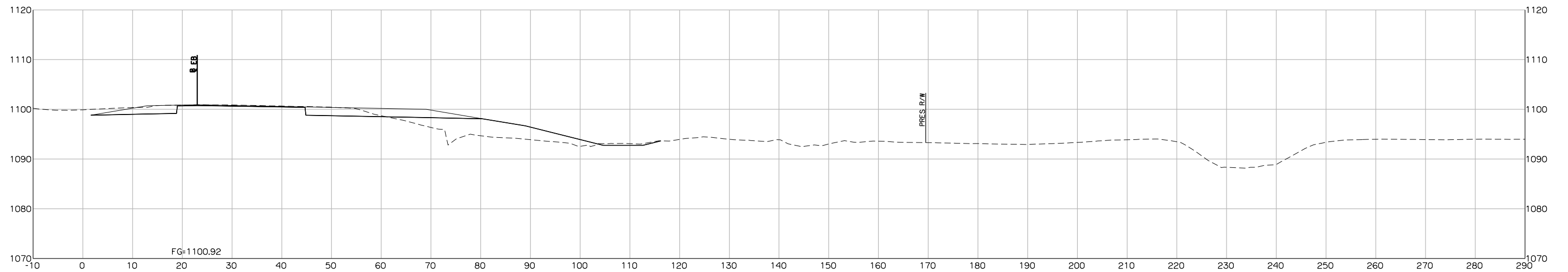

3049+99.10

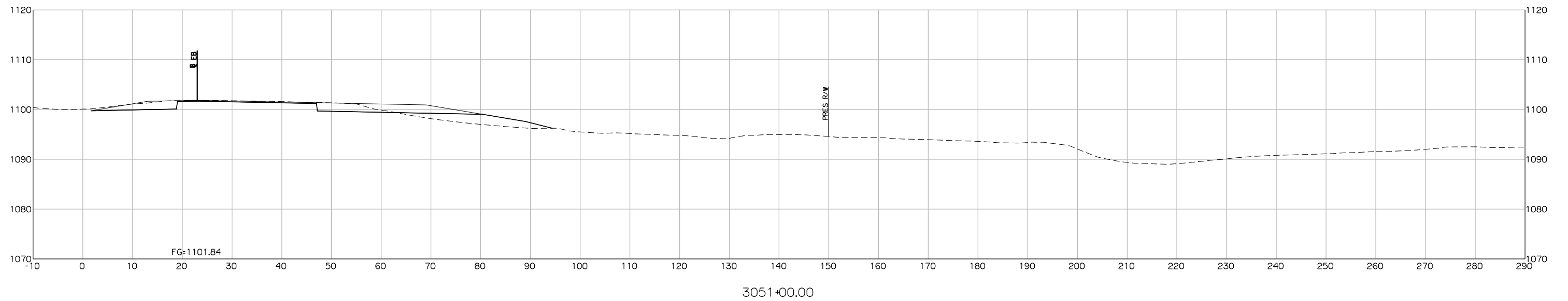
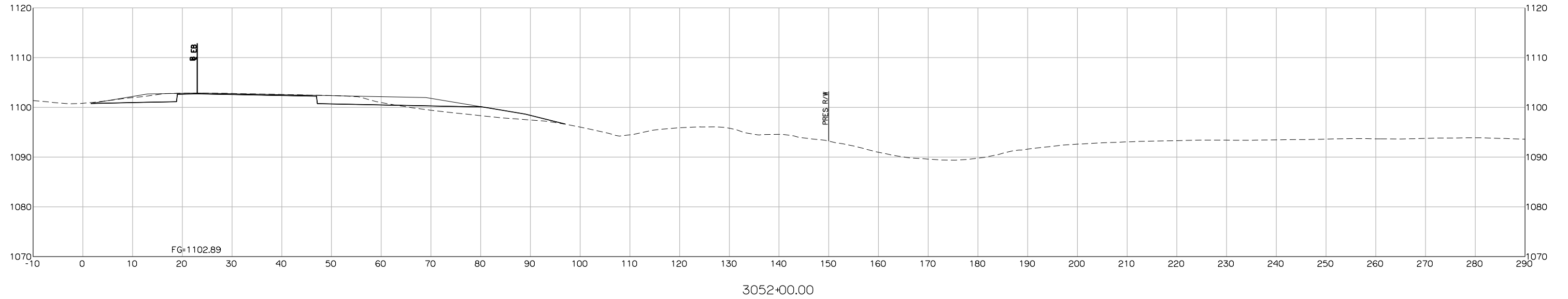

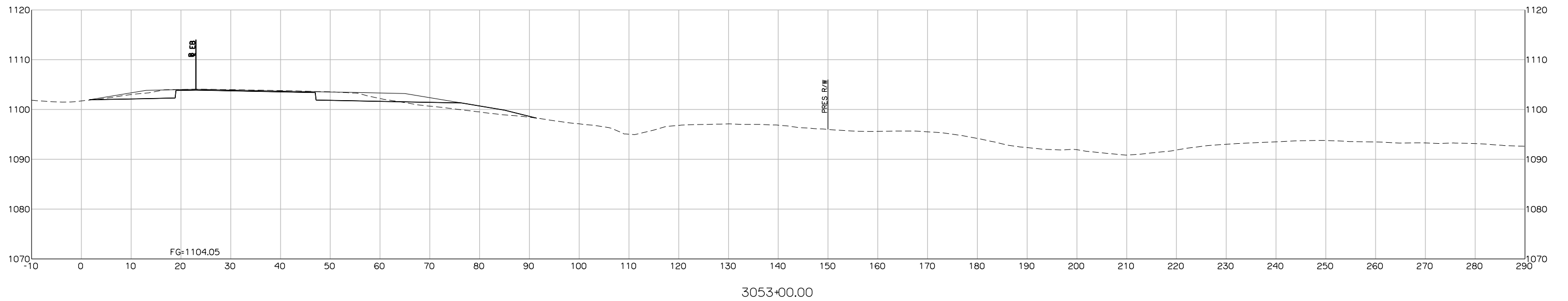
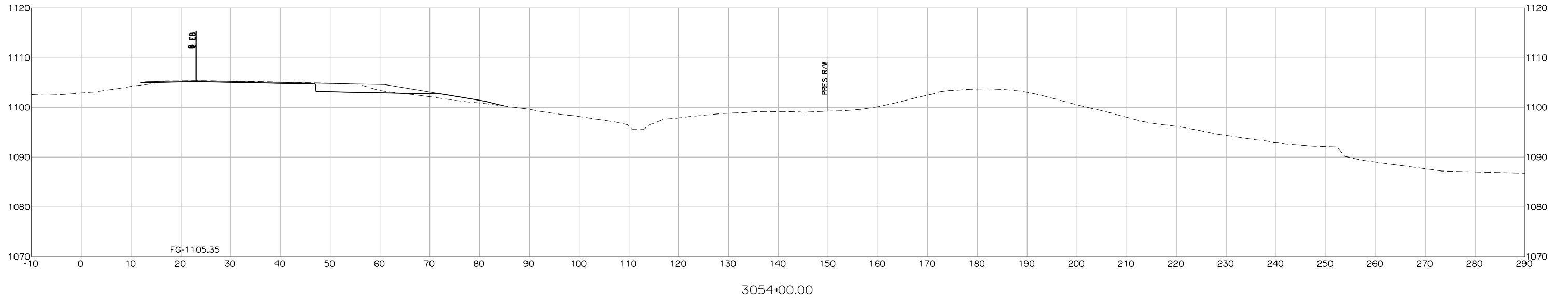

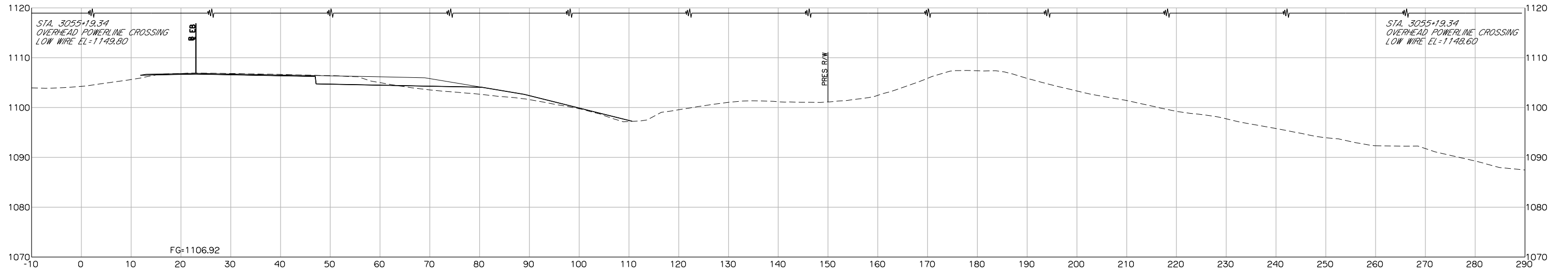

3055+19.34

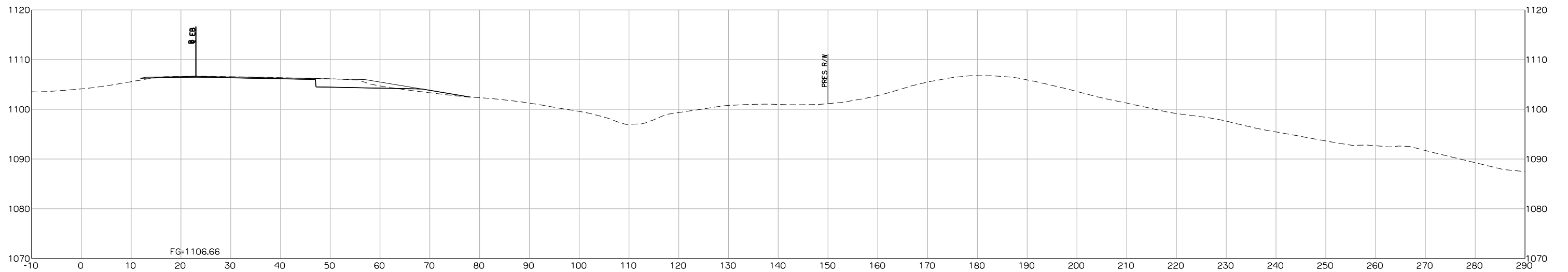

3055+00.00

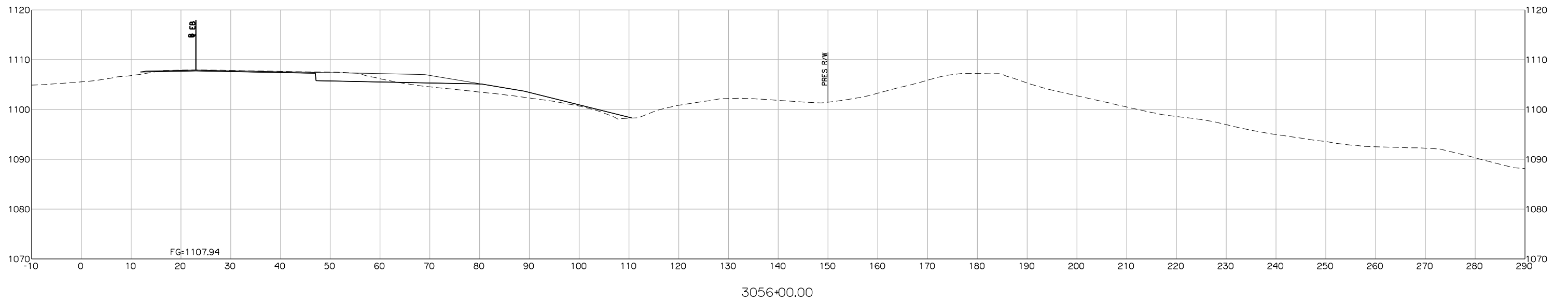
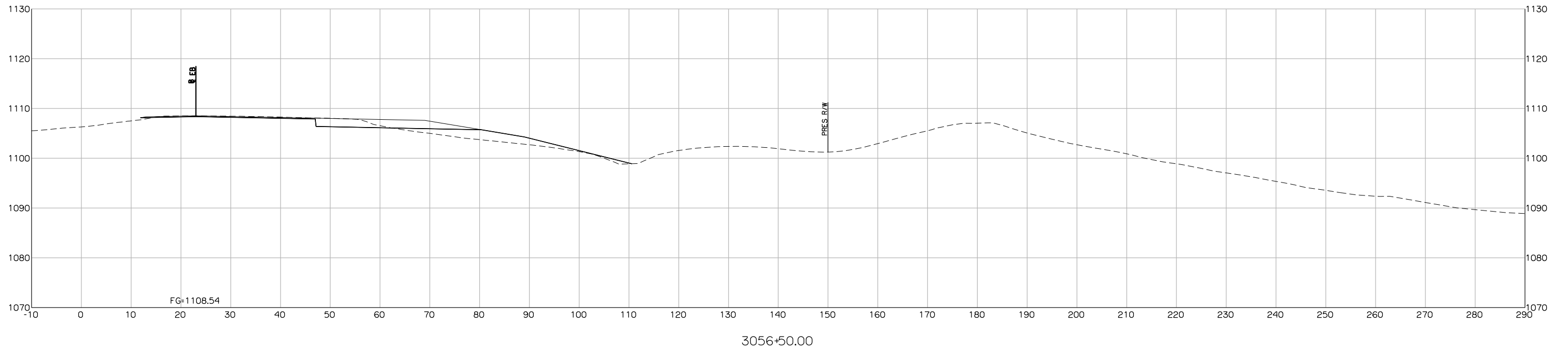

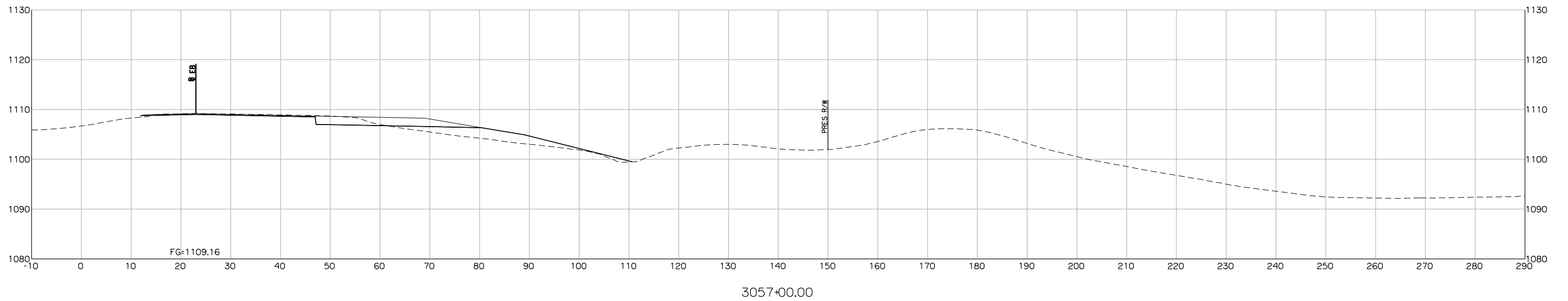
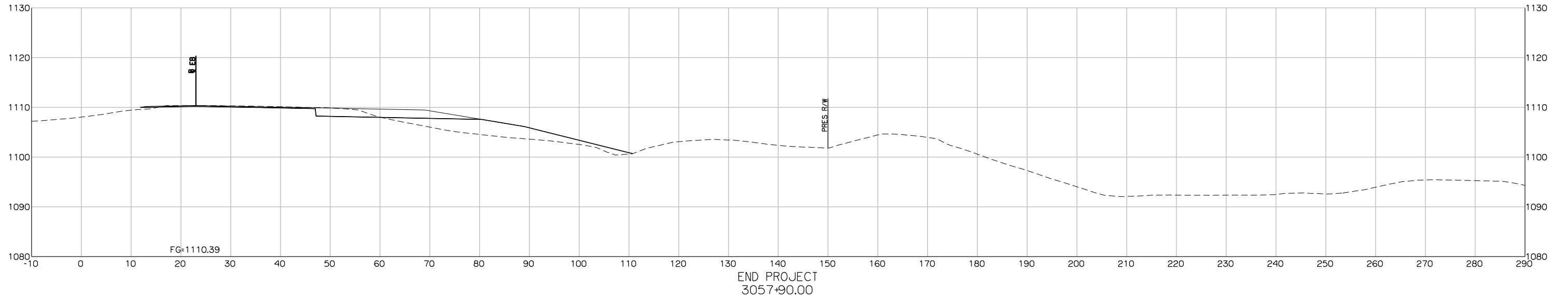

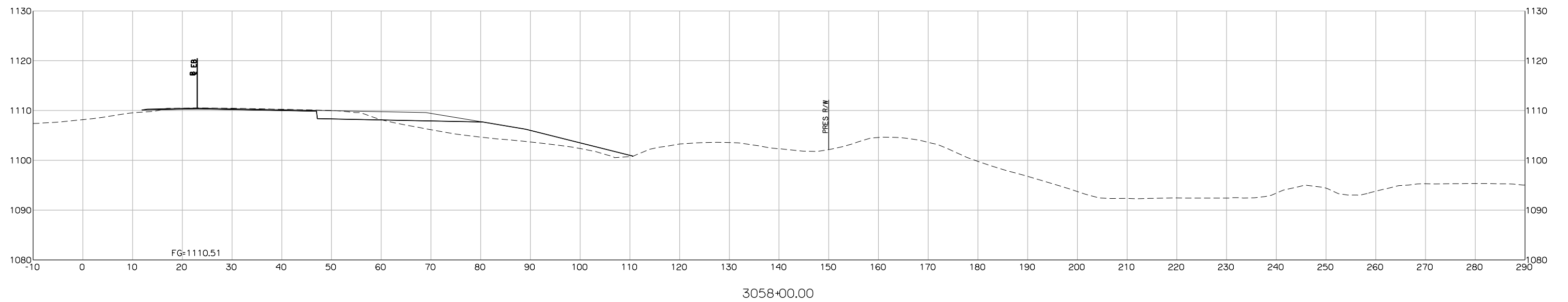
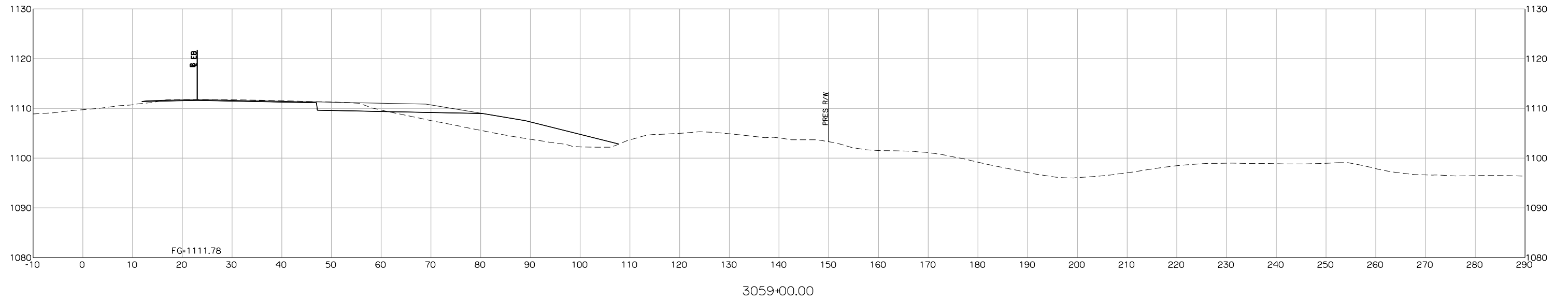

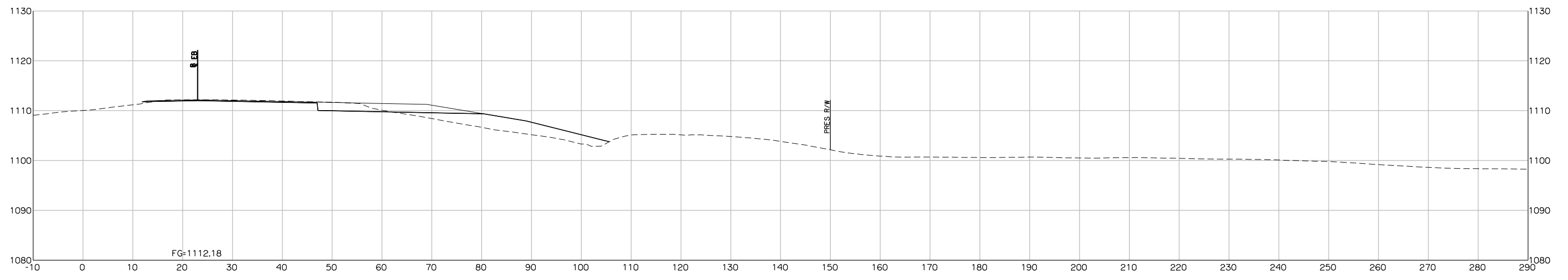

FG=1112.18

3059+31.20

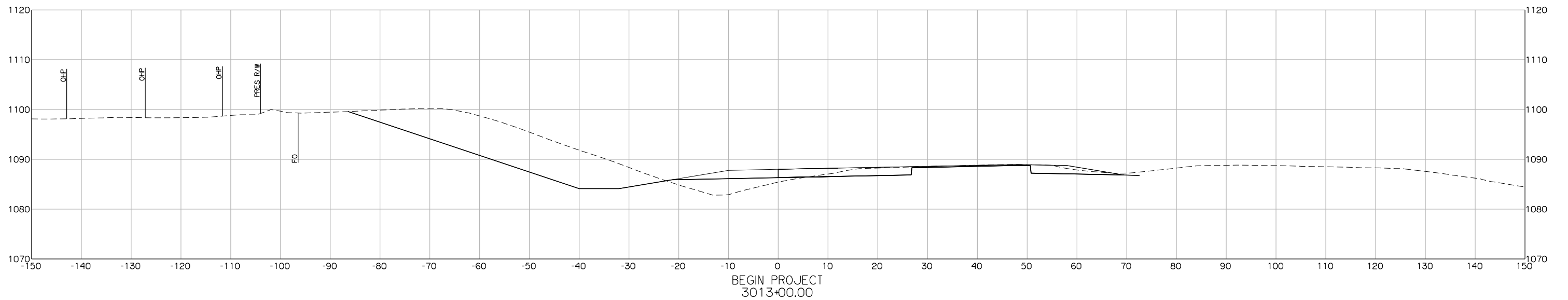
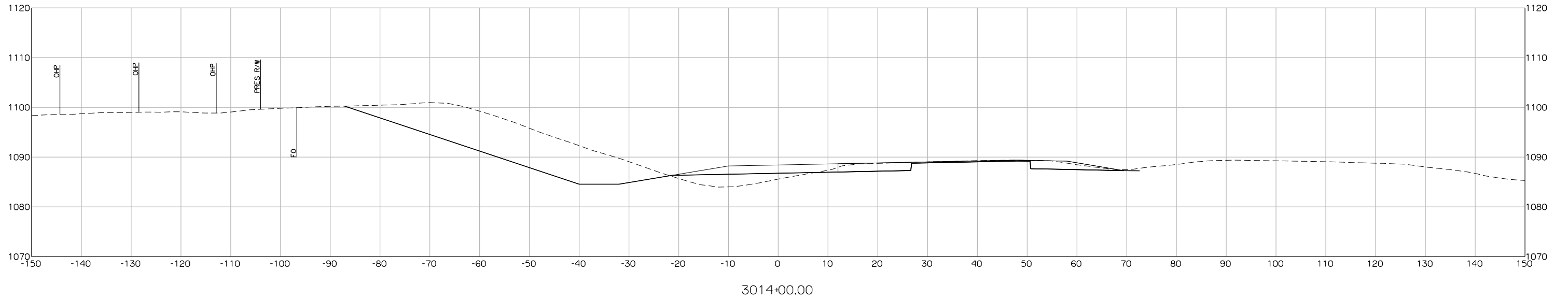

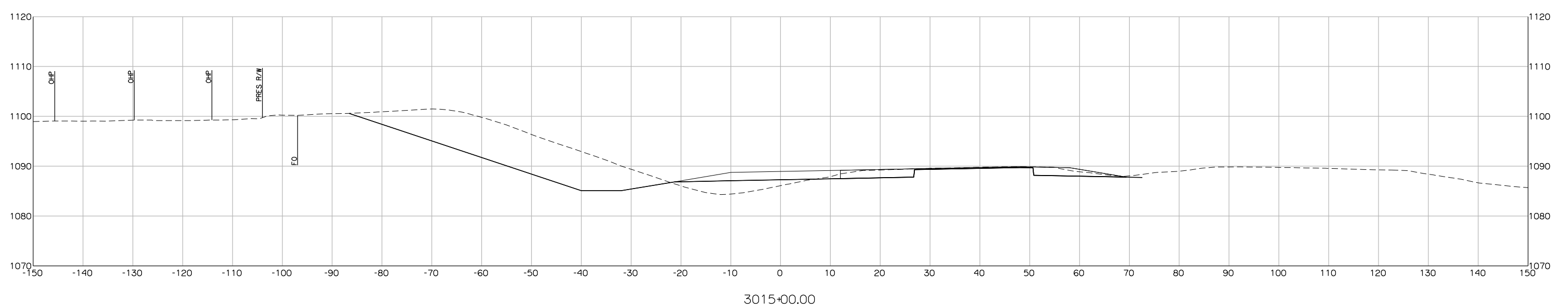
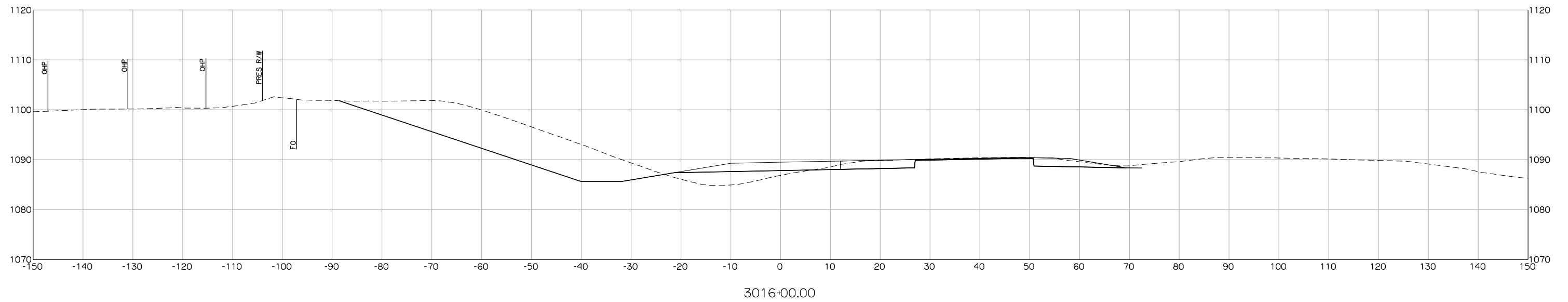

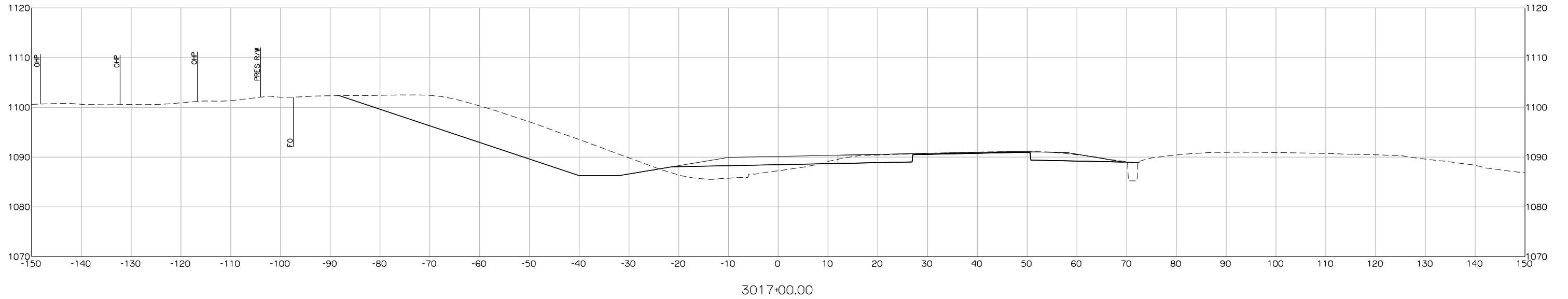

3017+00.00

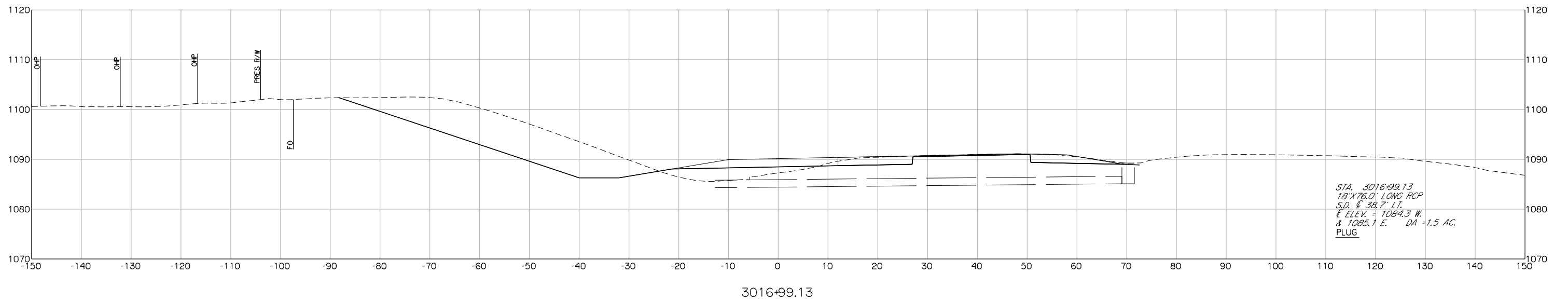

3016+99.13

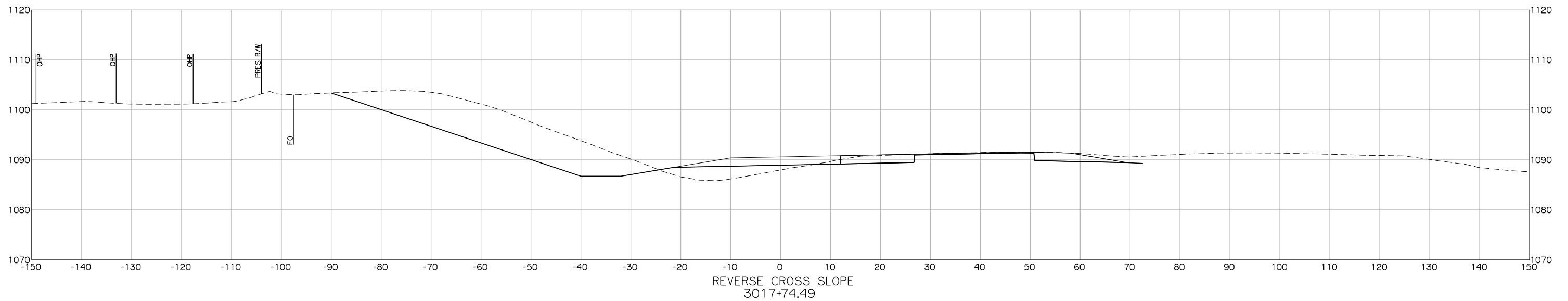
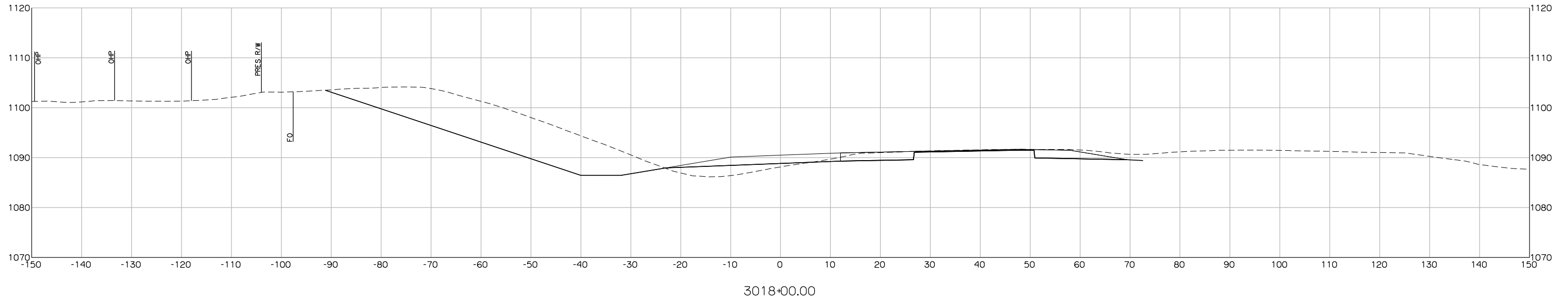

REVERSE CROSS SLOPE
3017+74.49

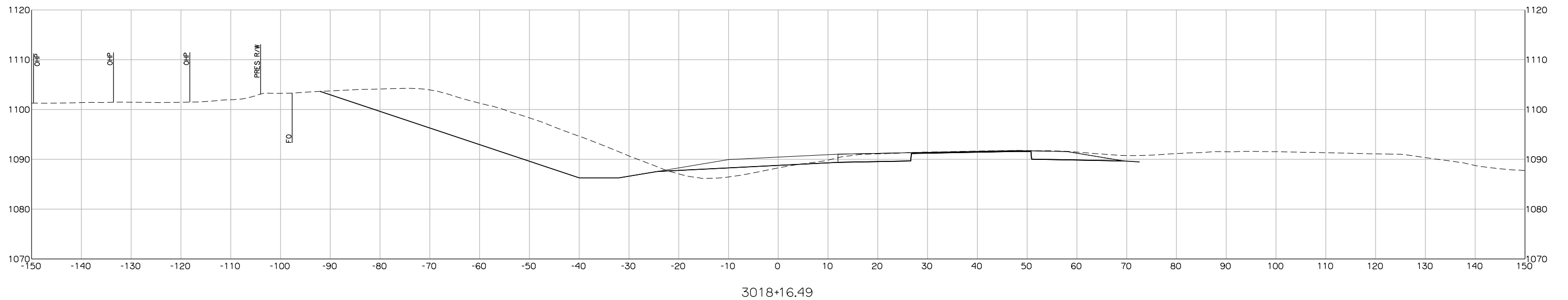
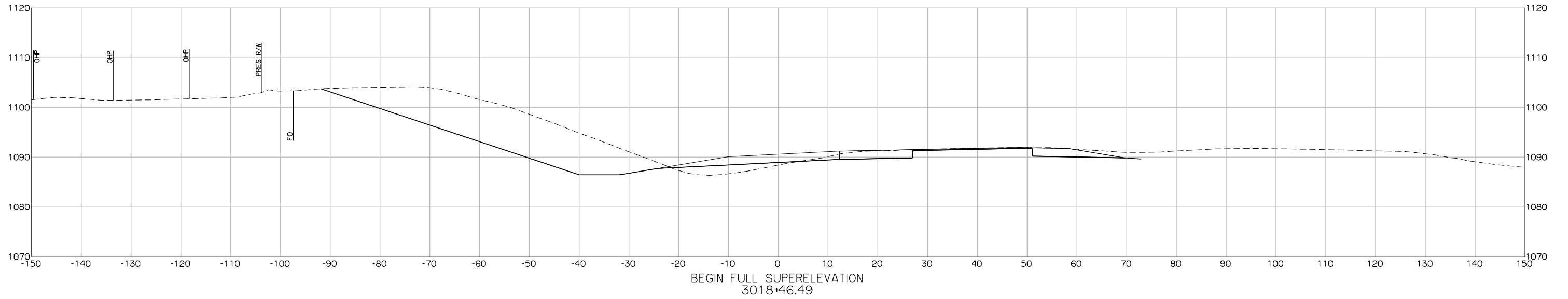

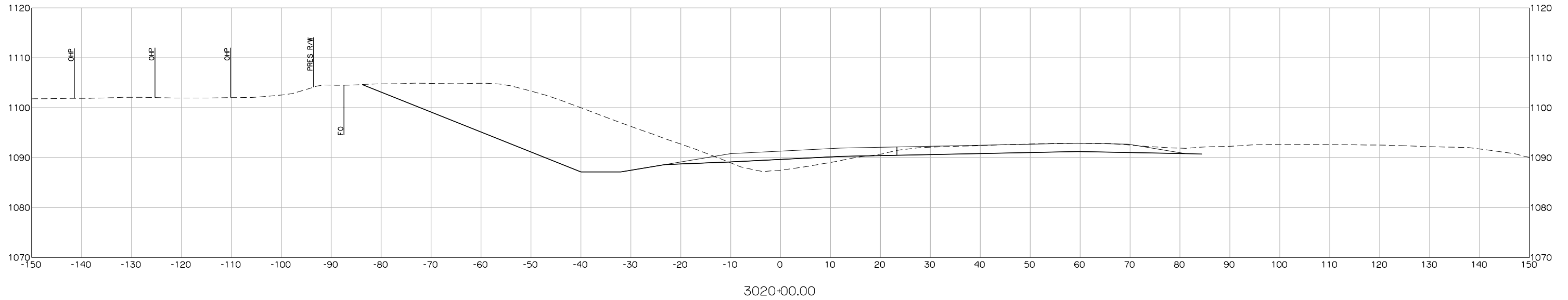

3020+00.00

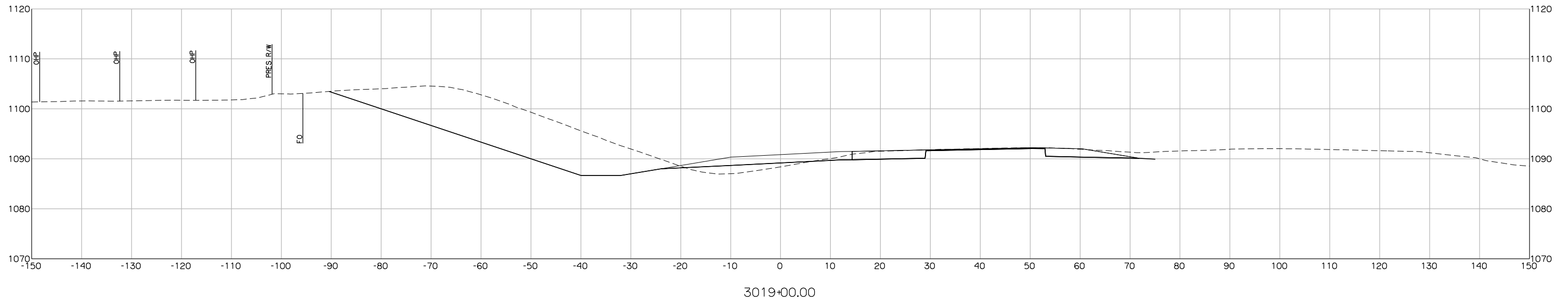

3019+00.00

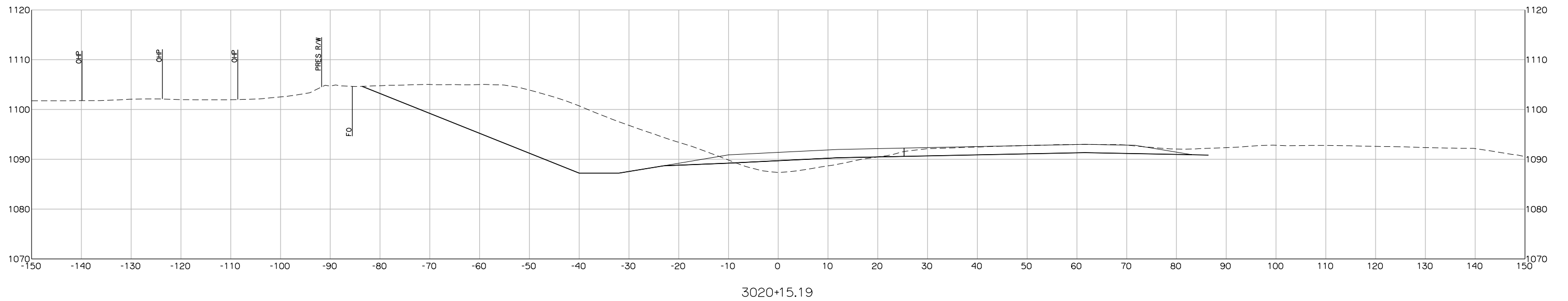
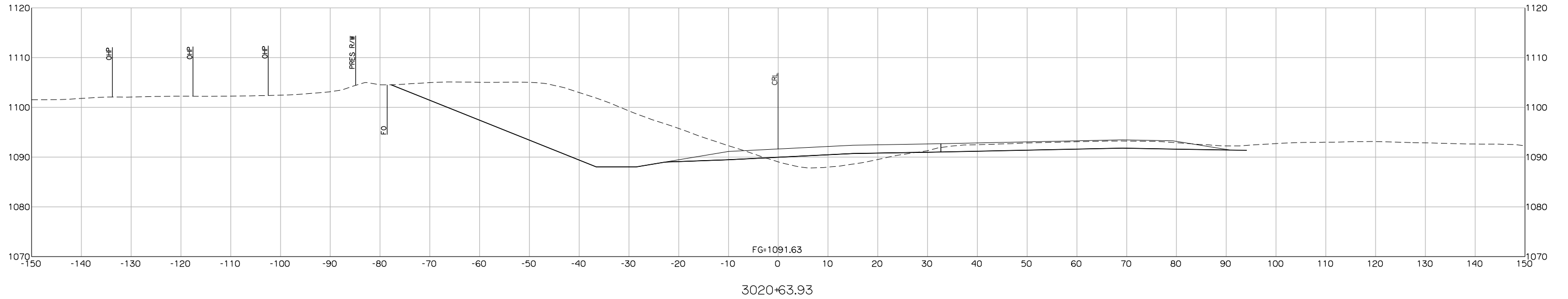

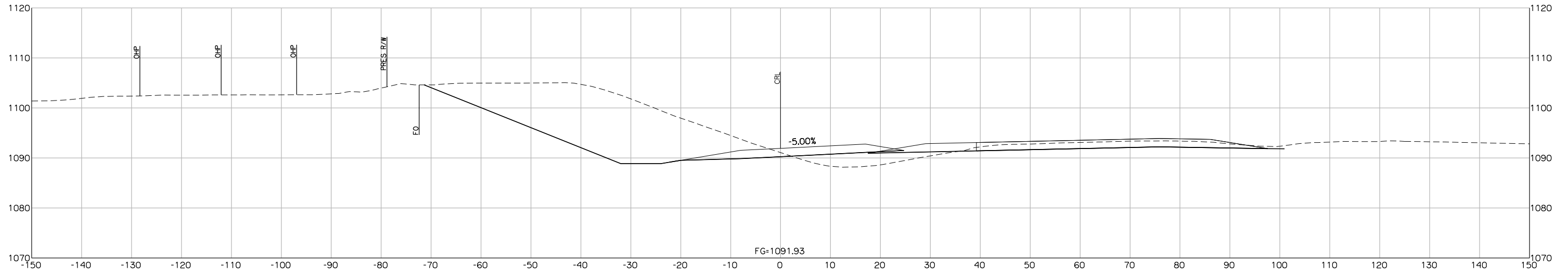

3021+00.00

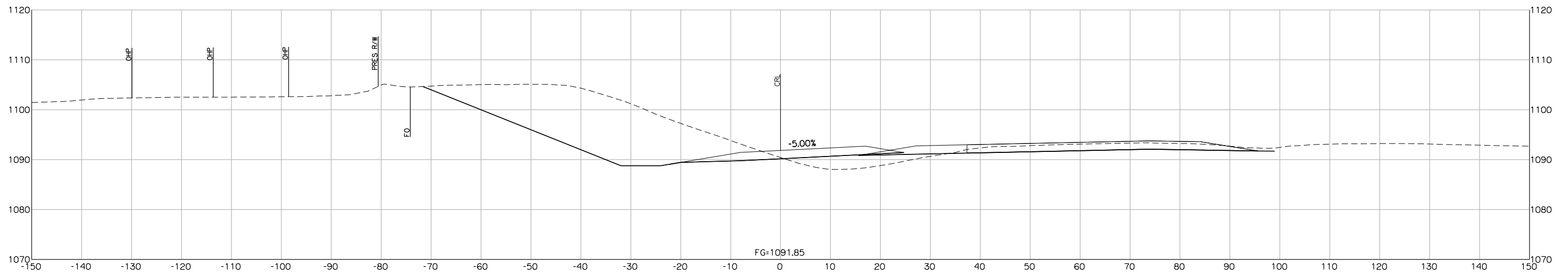

3020+90.10

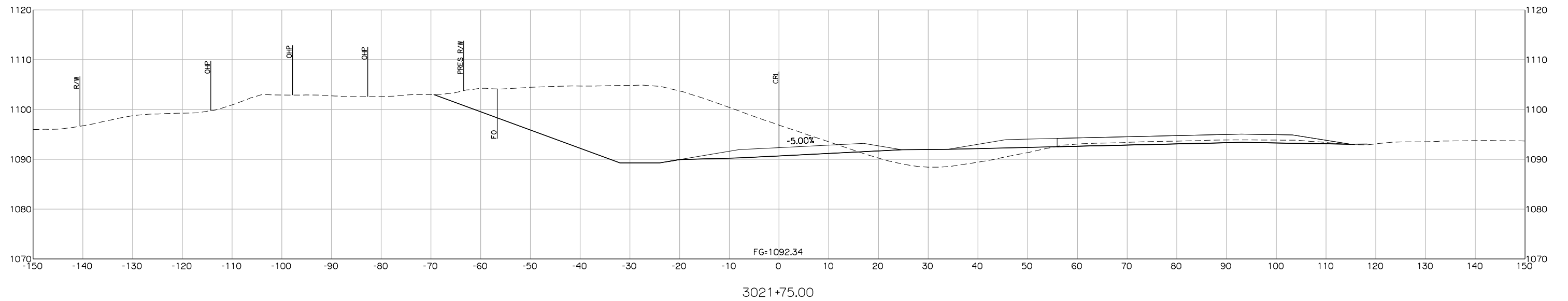
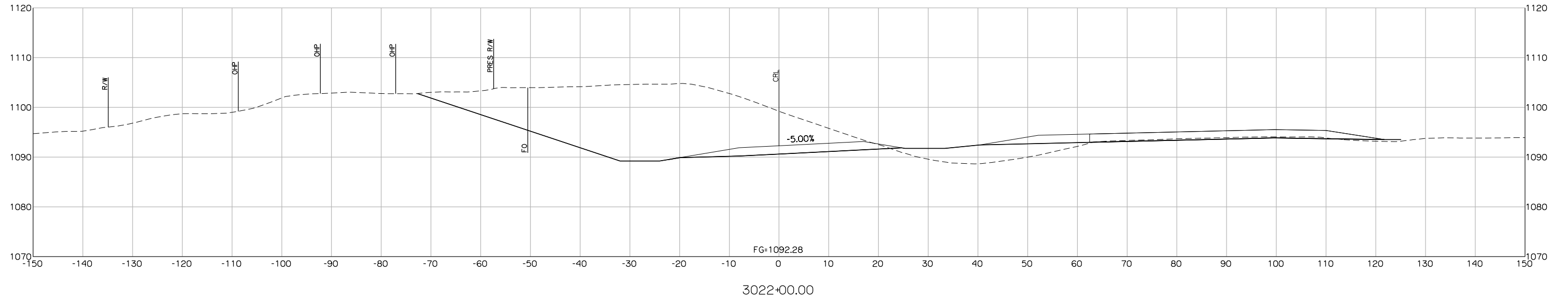

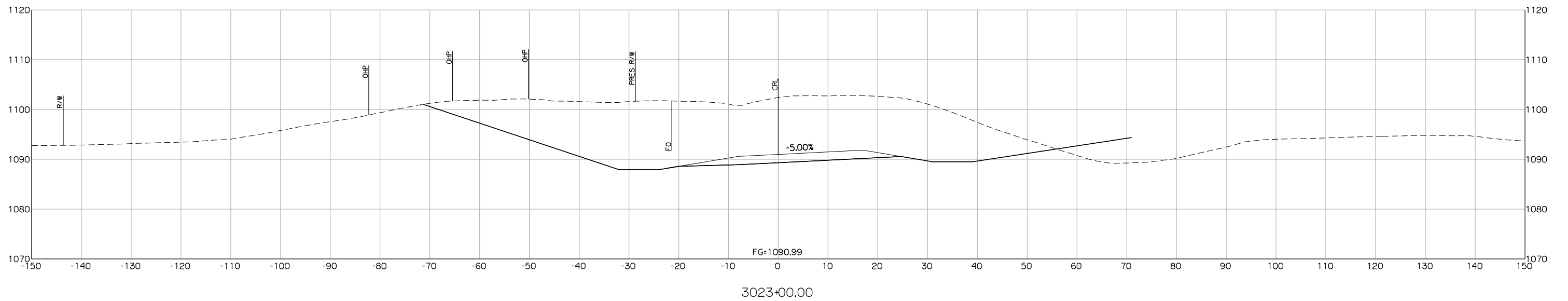
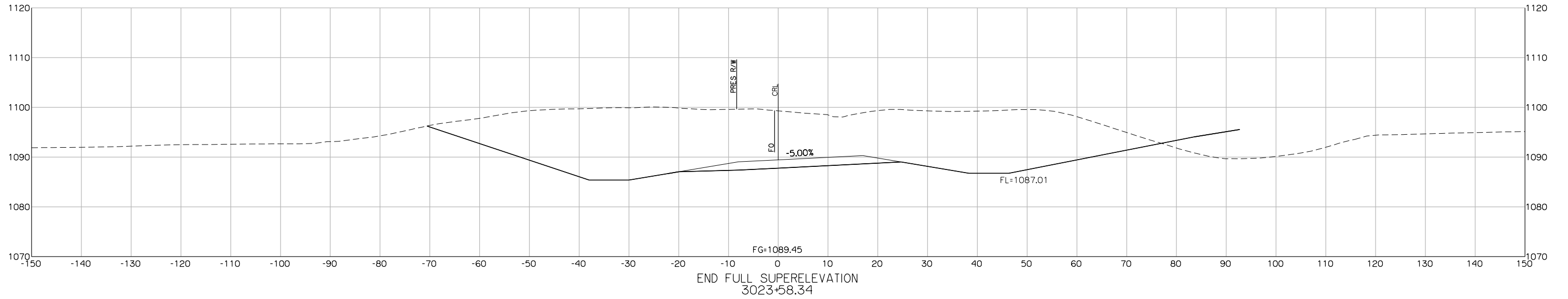

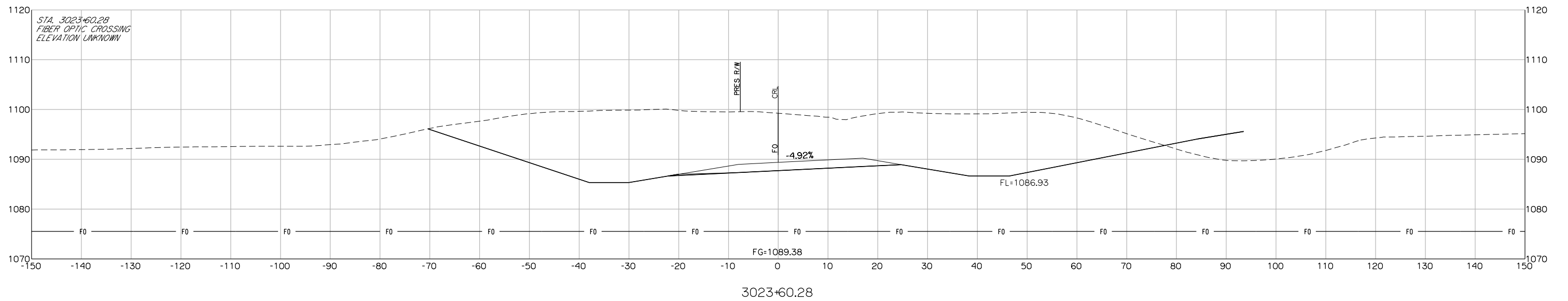
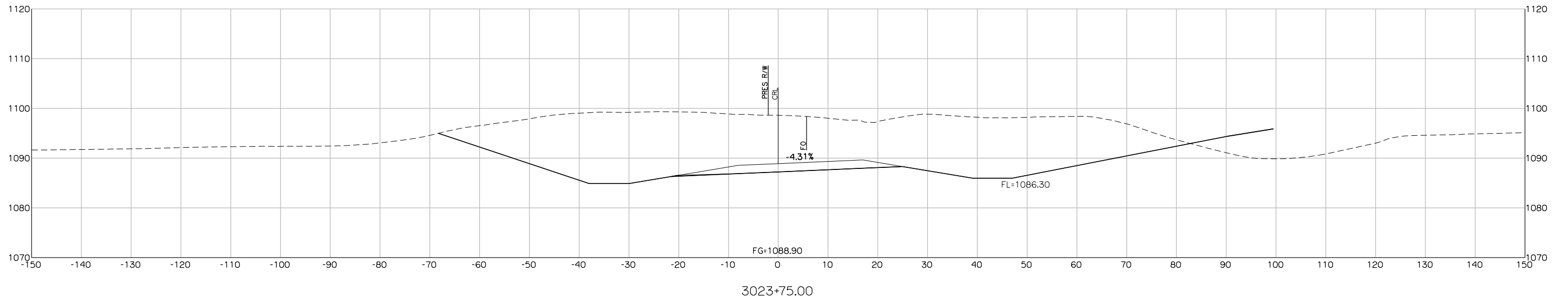

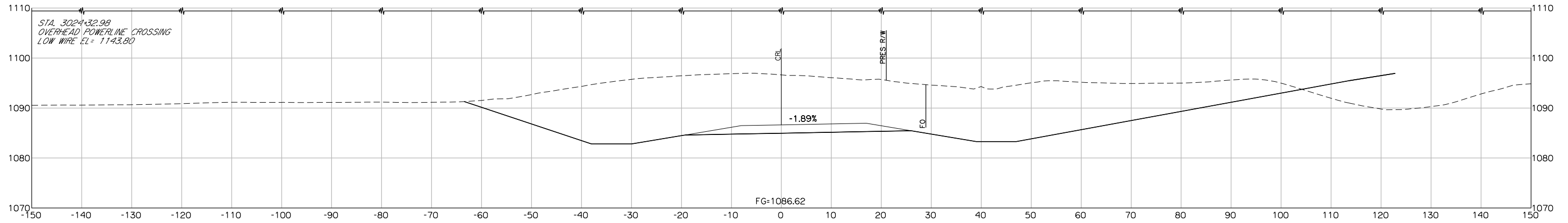

3024+32.98

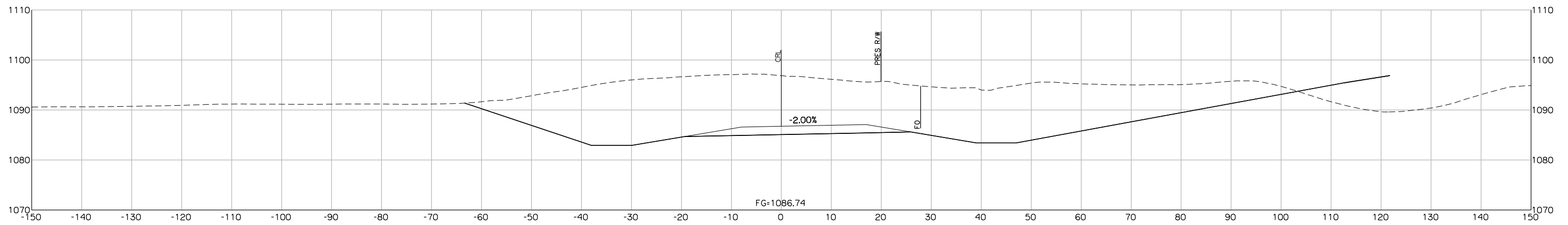

REVERSE CROSS SLOPE
3024+30.34

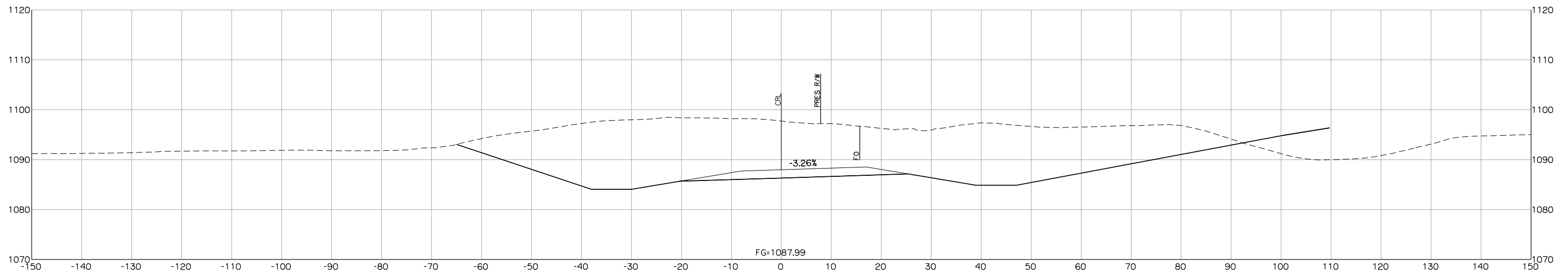

3024+00.00

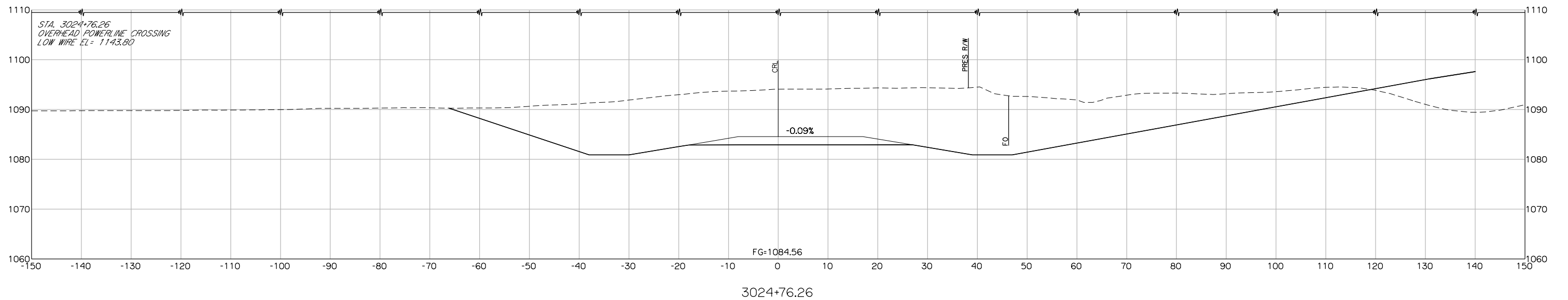
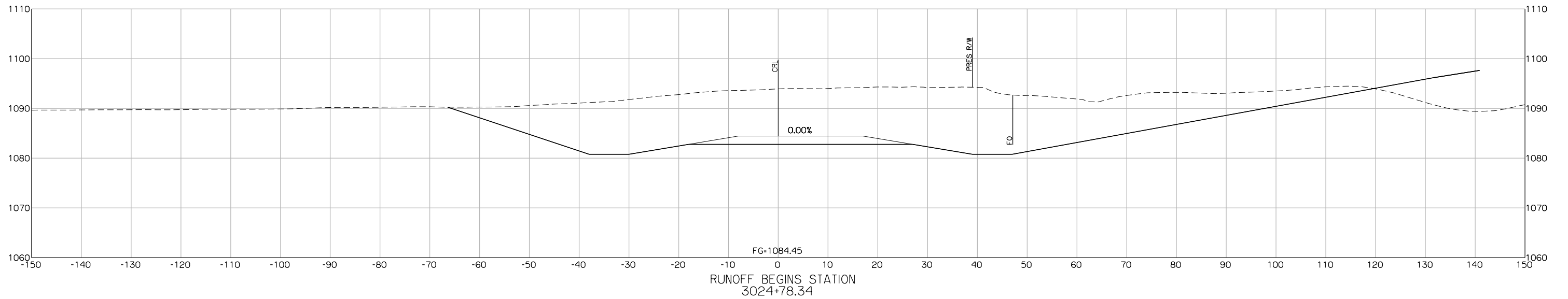

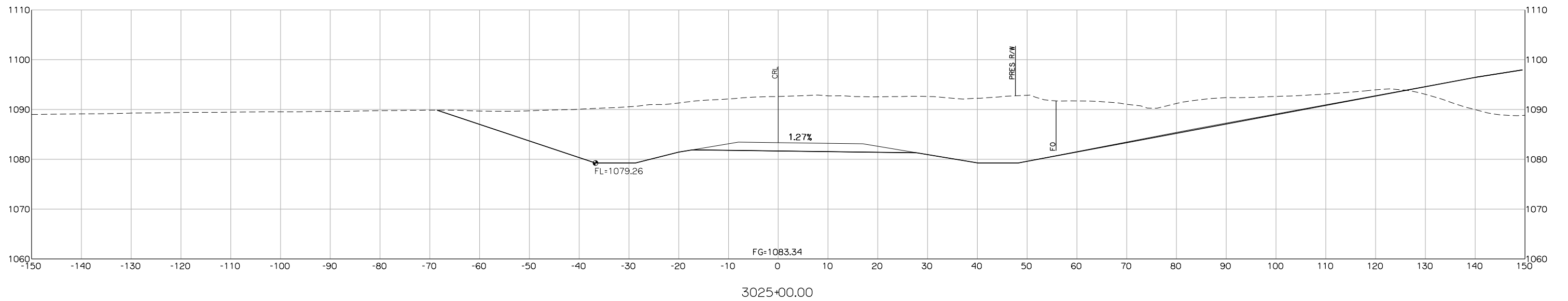
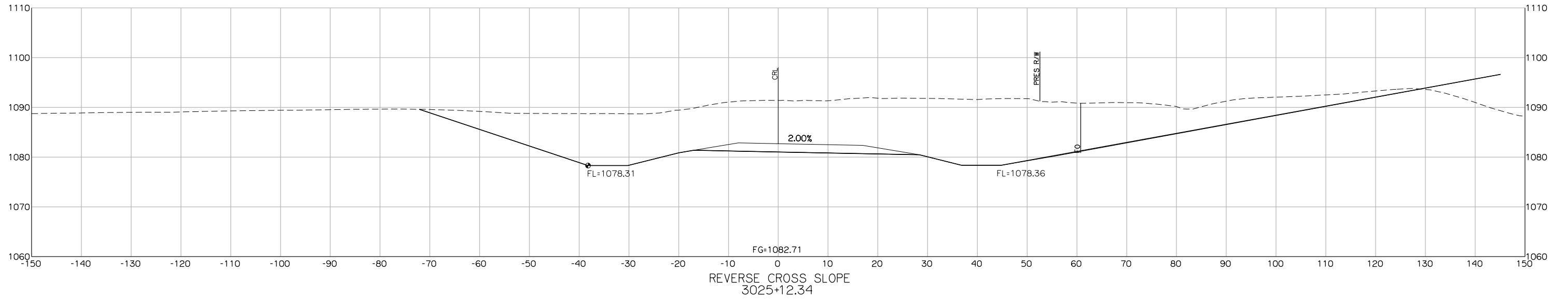

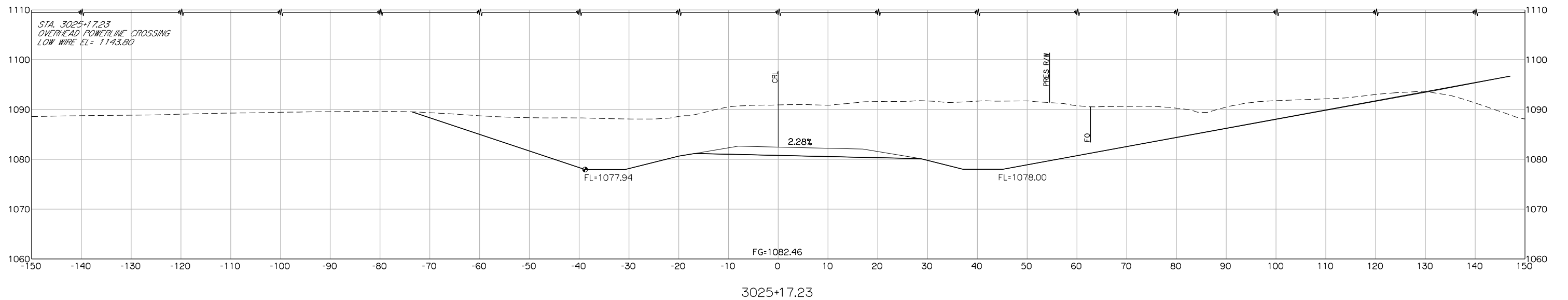
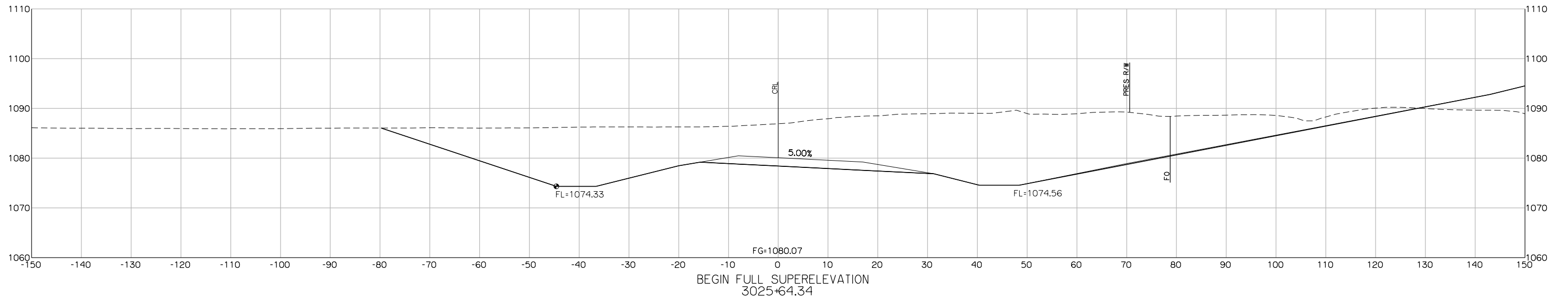

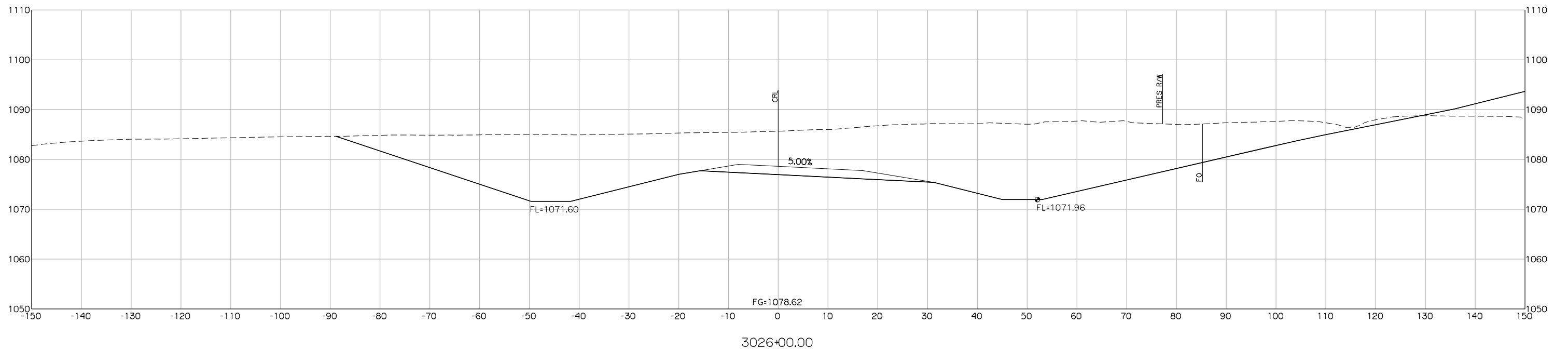
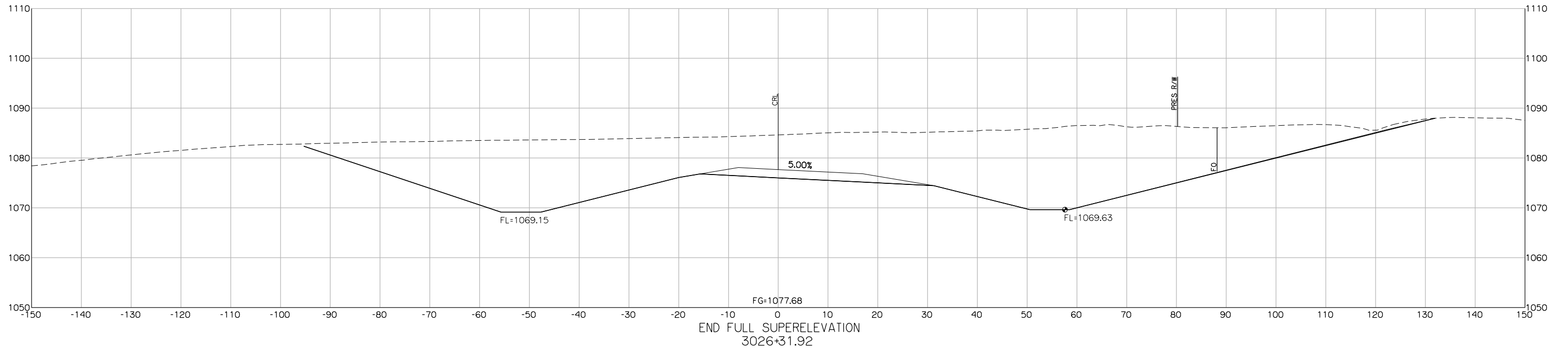

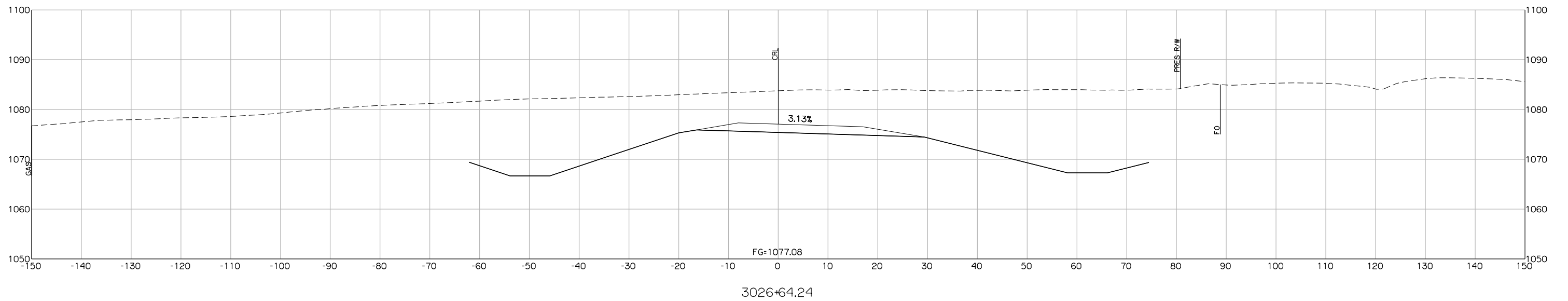
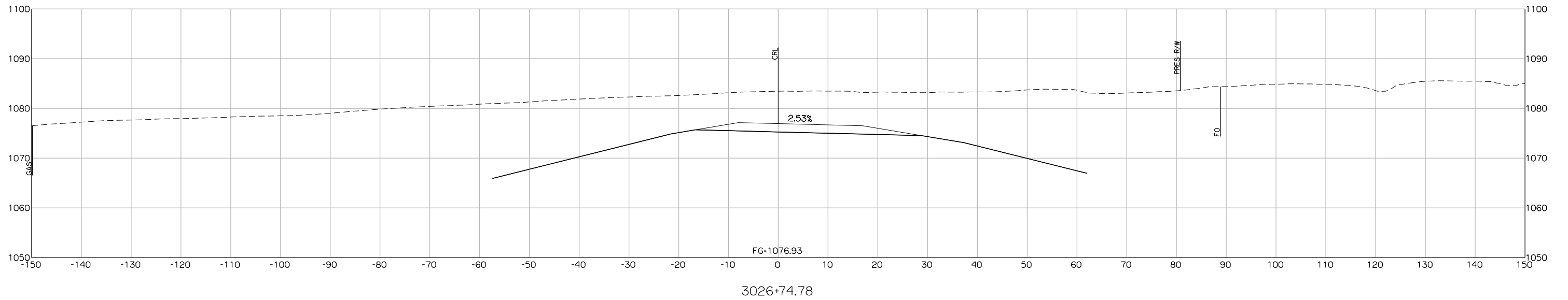

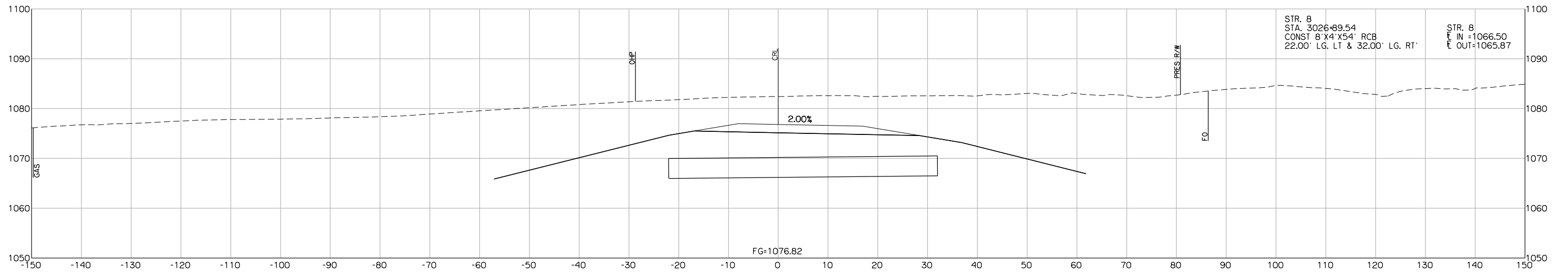

3026+89.53

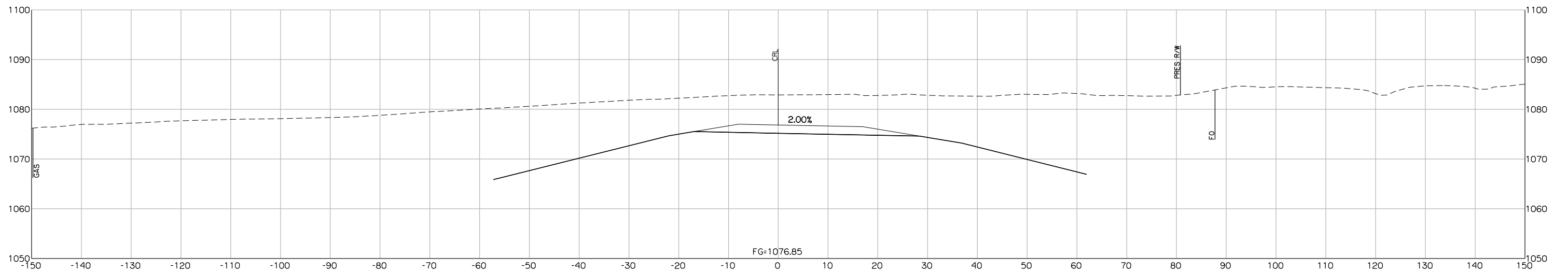

REVERSE CROSS SLOPE
3026+83.92

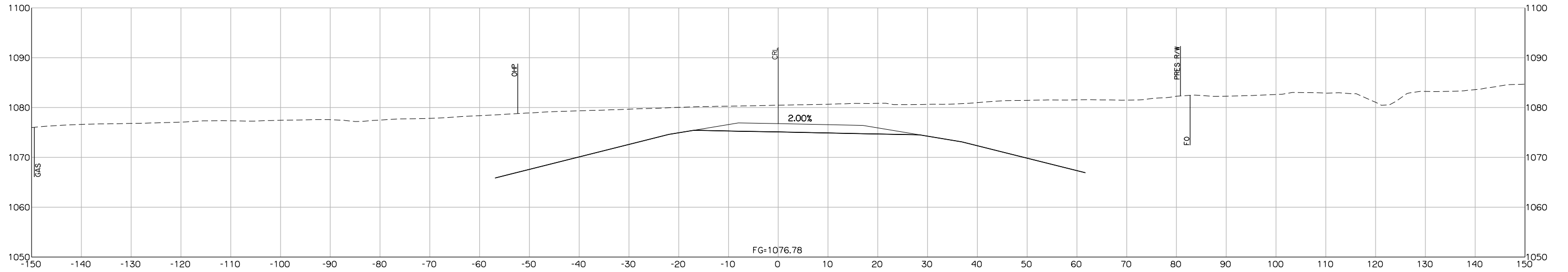

3027+04.28

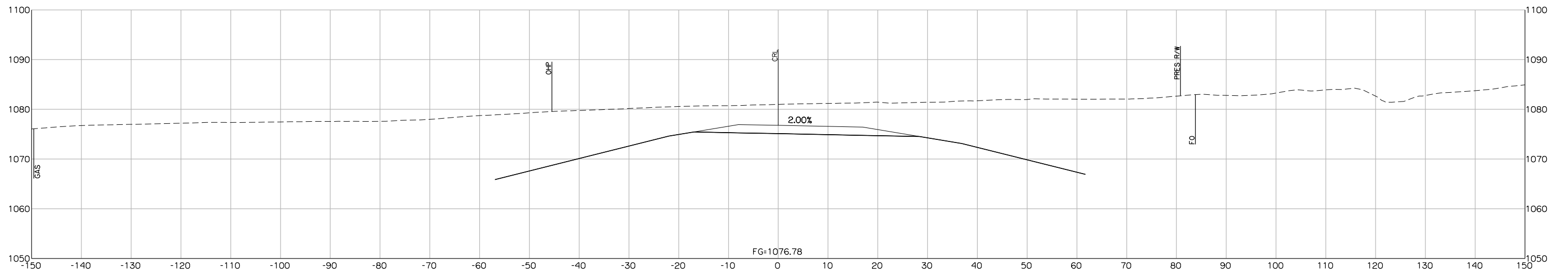

3027+00.00

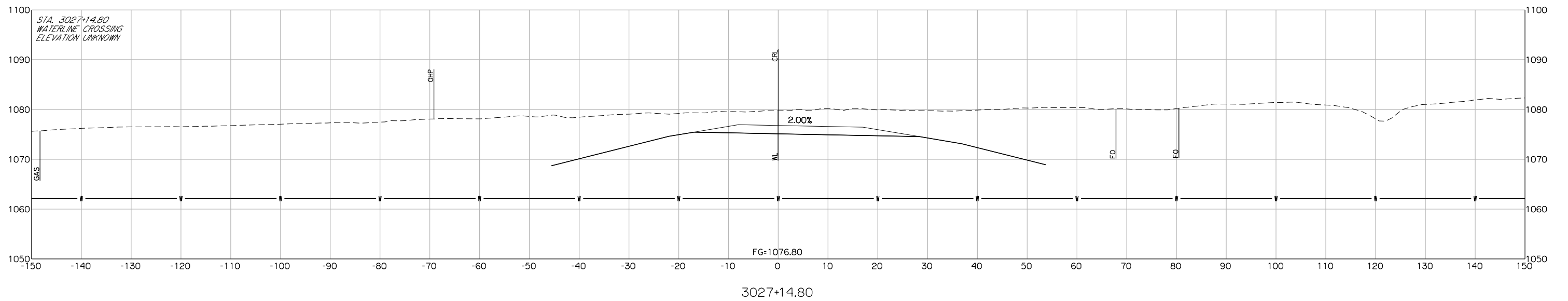
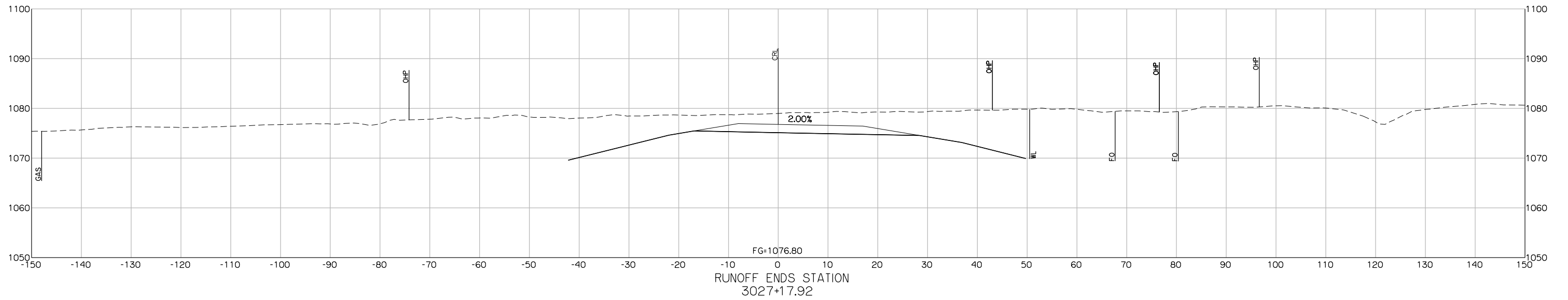

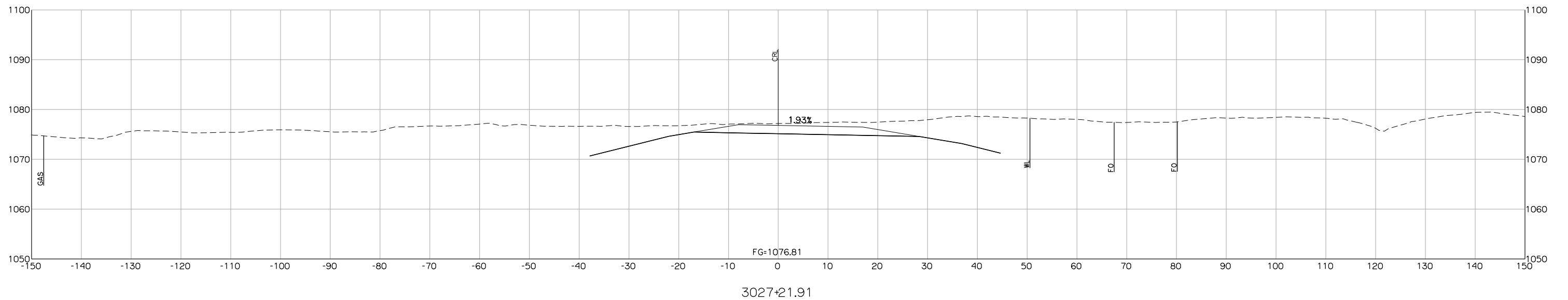
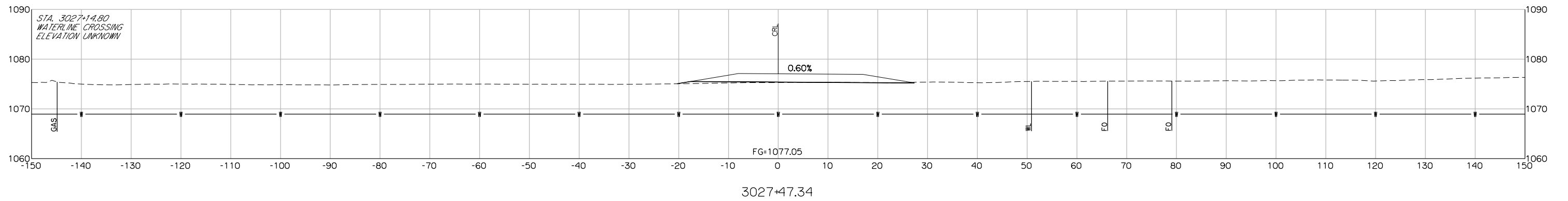
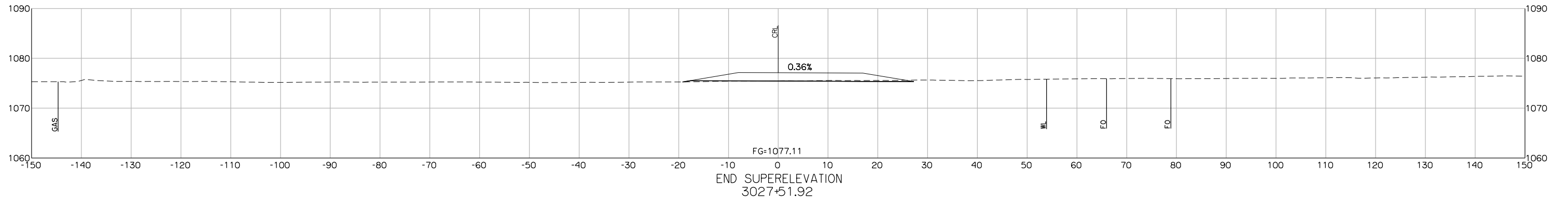

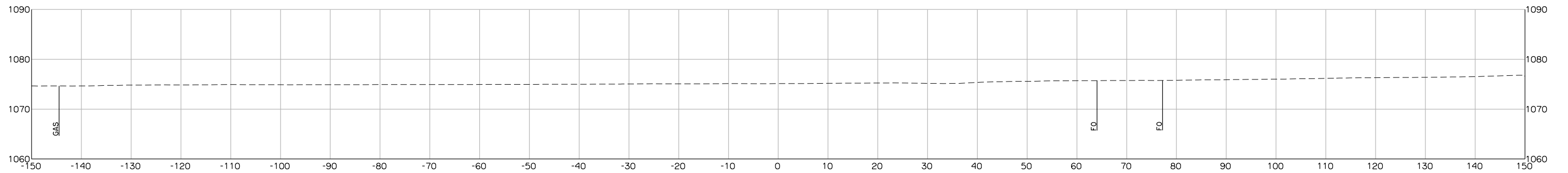

3027+89.53

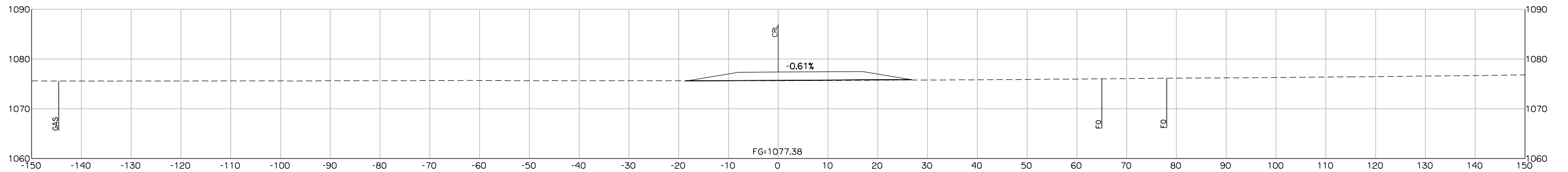

FG=1077.38

END PROJECT
3027+70.53

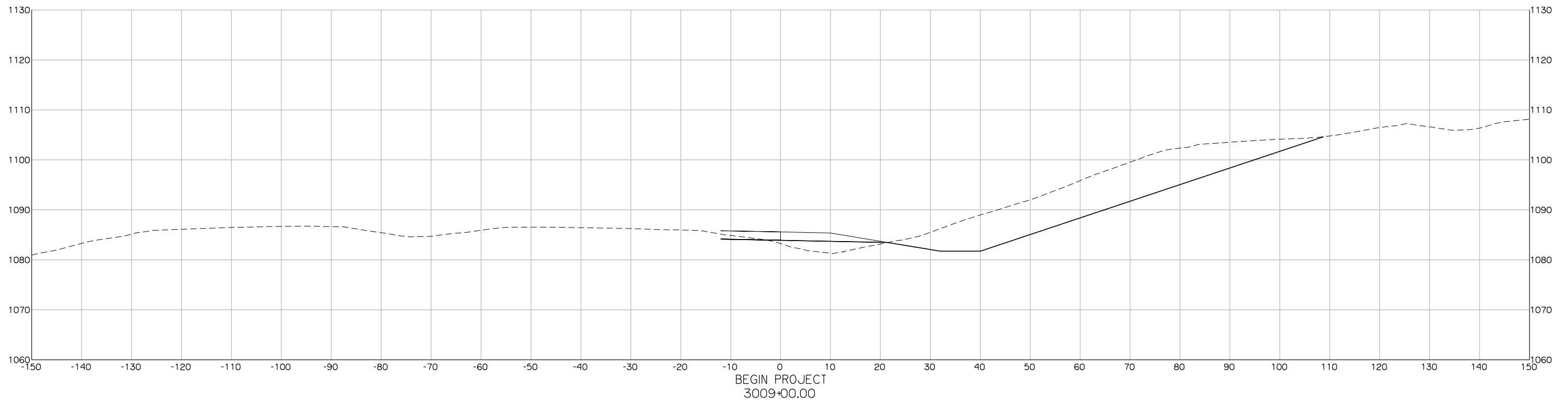
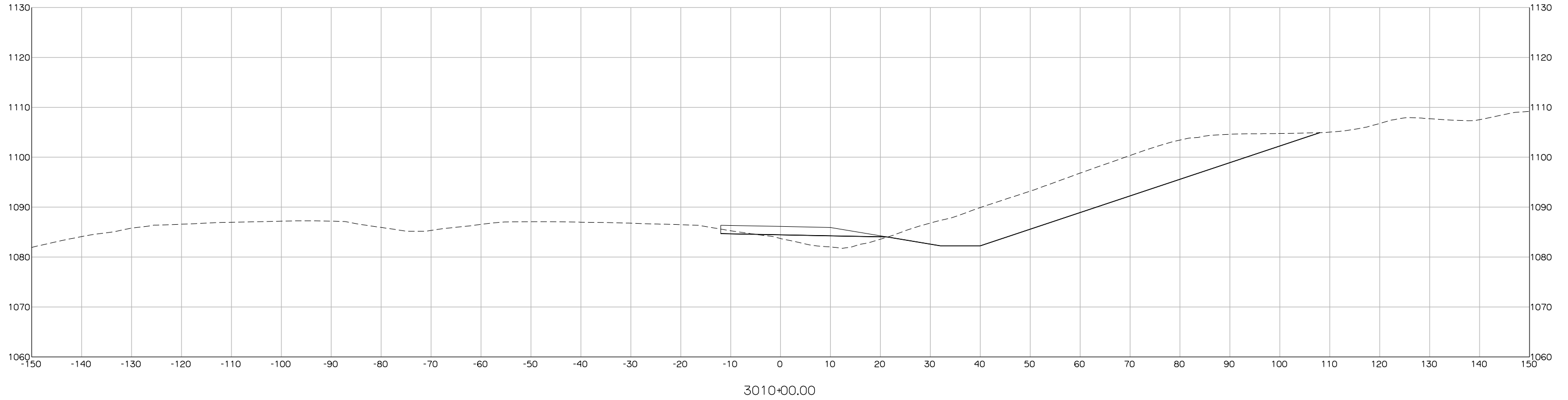

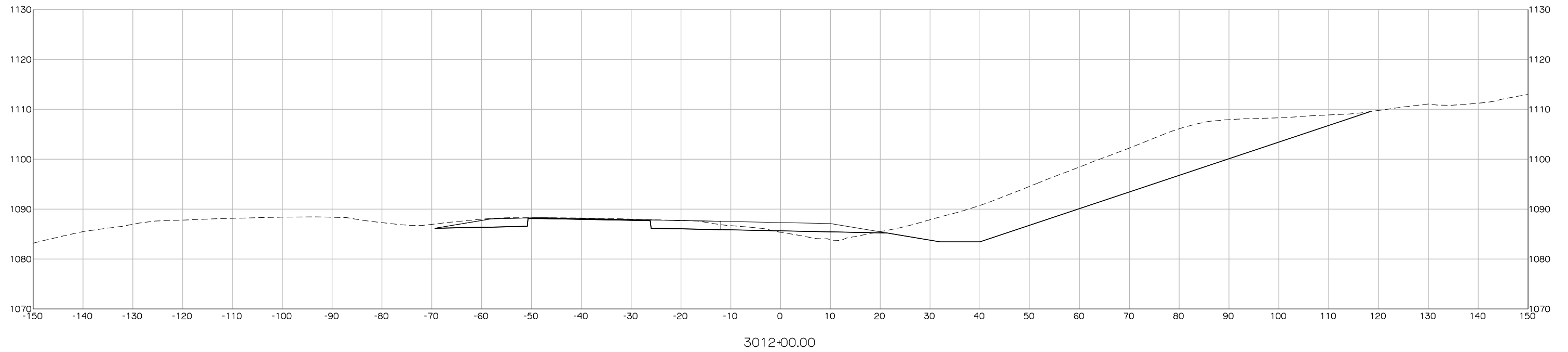

3012+00.00

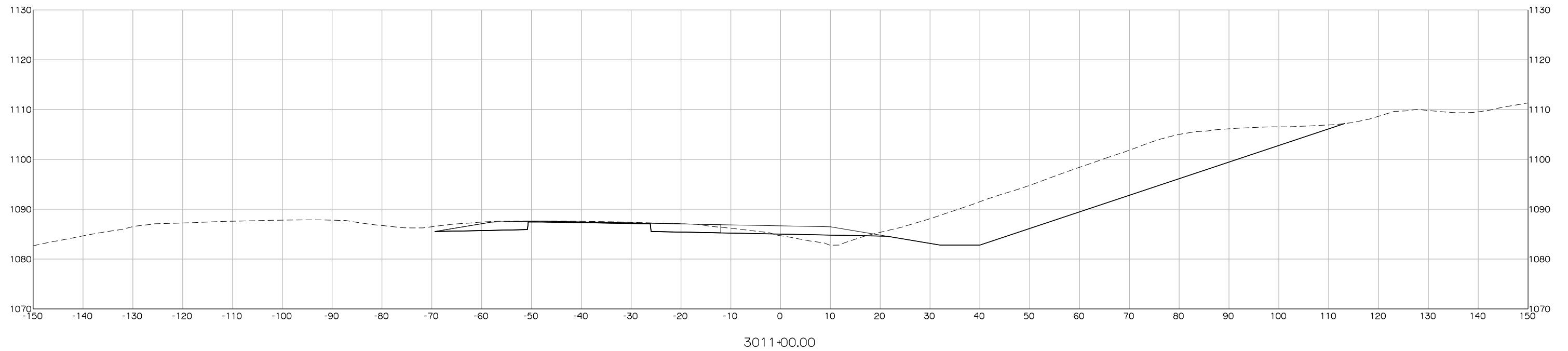

3011+00.00

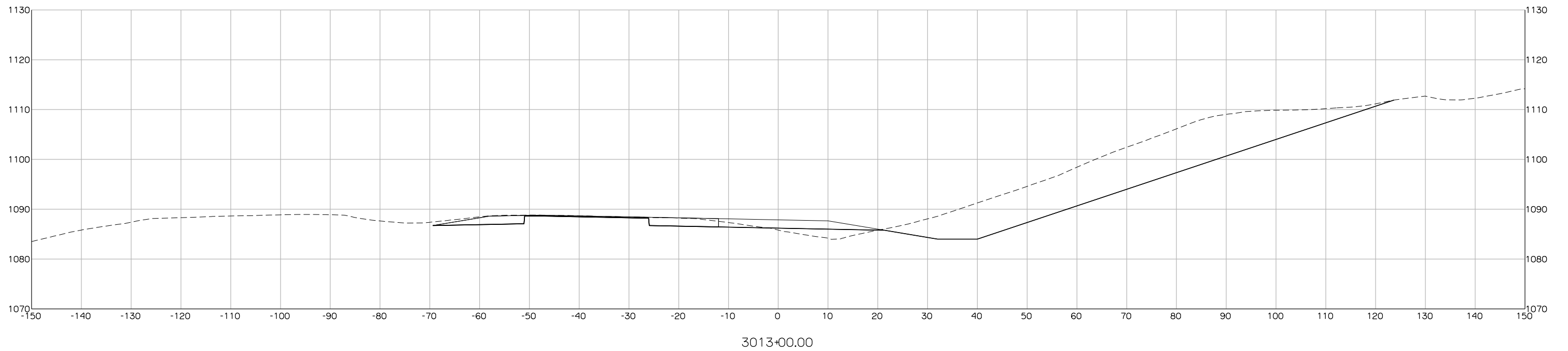
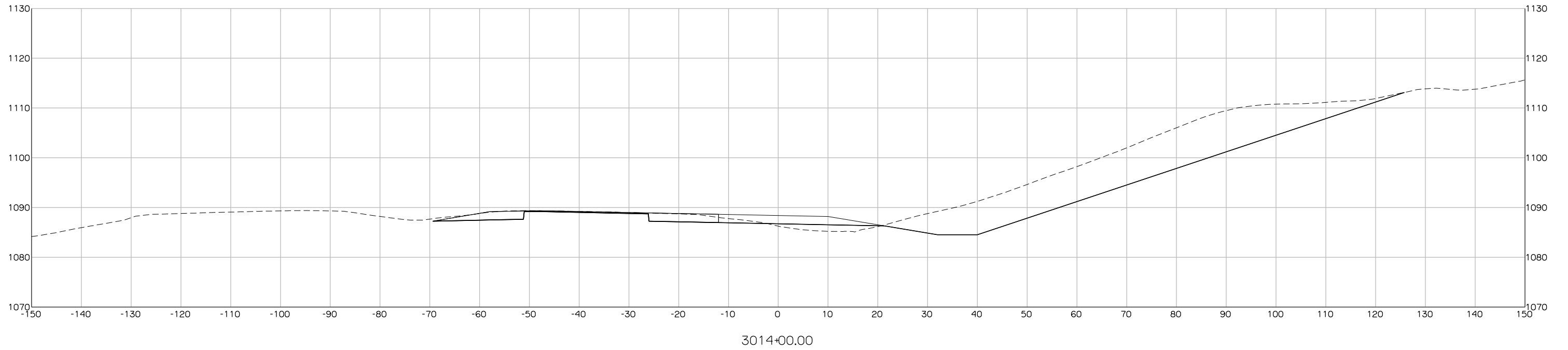

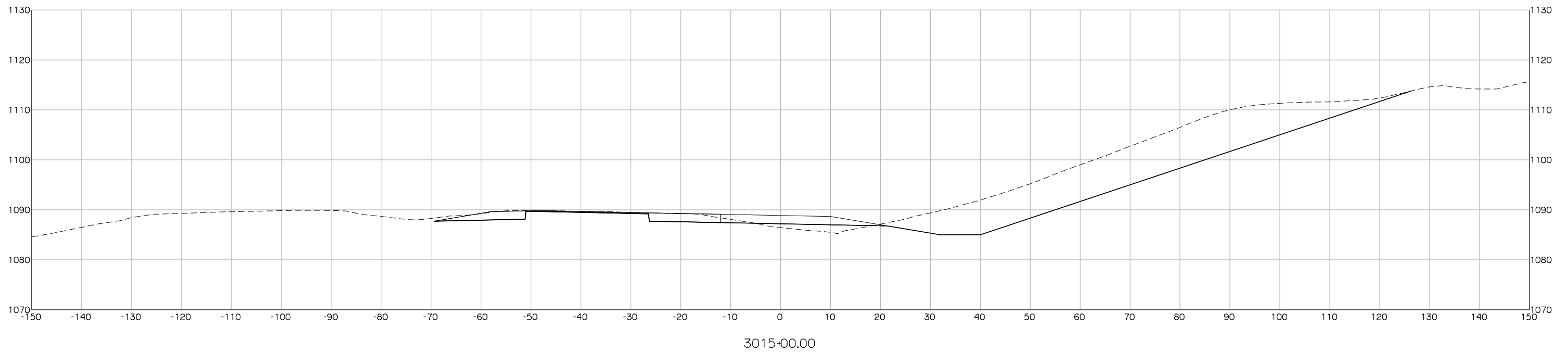
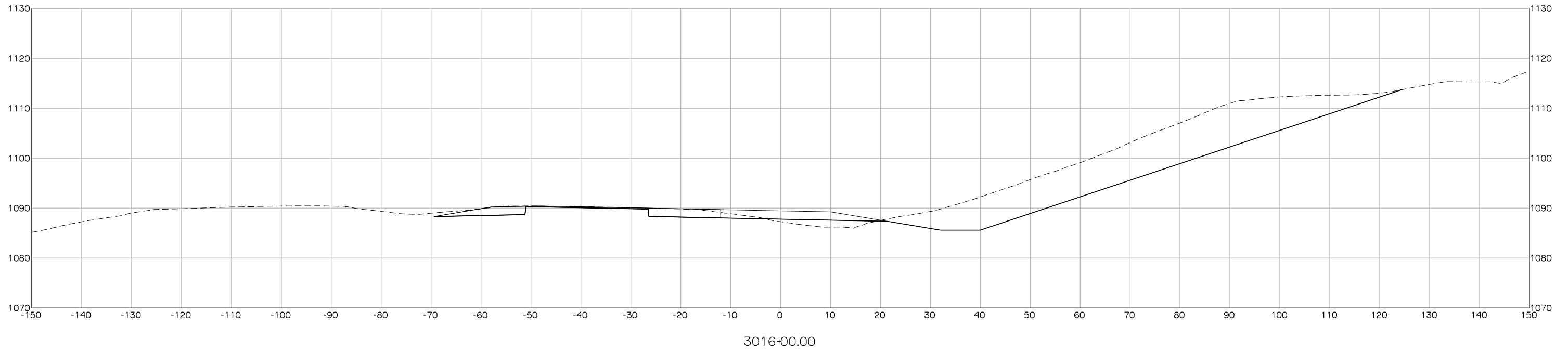

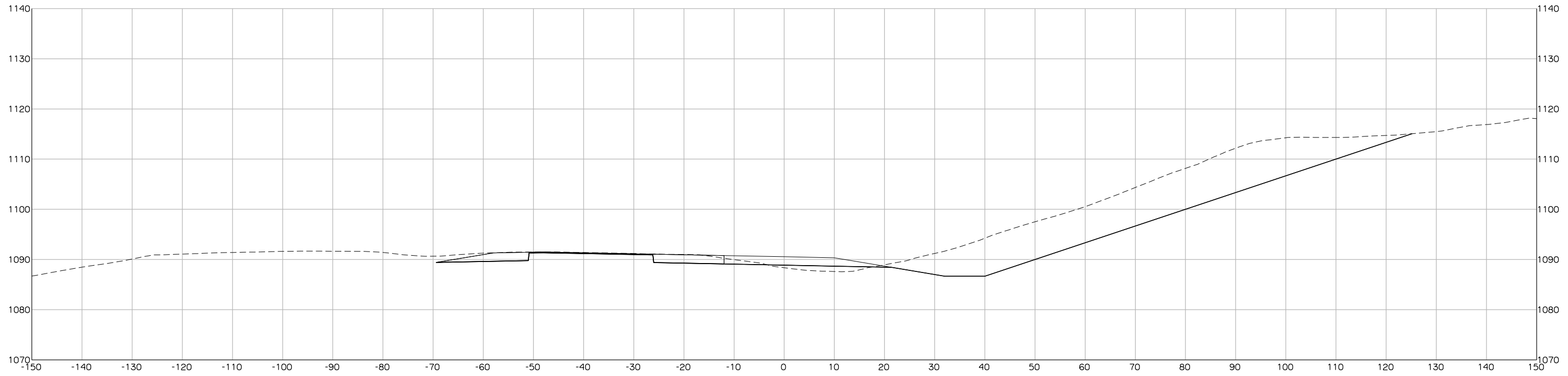

3018+00.00

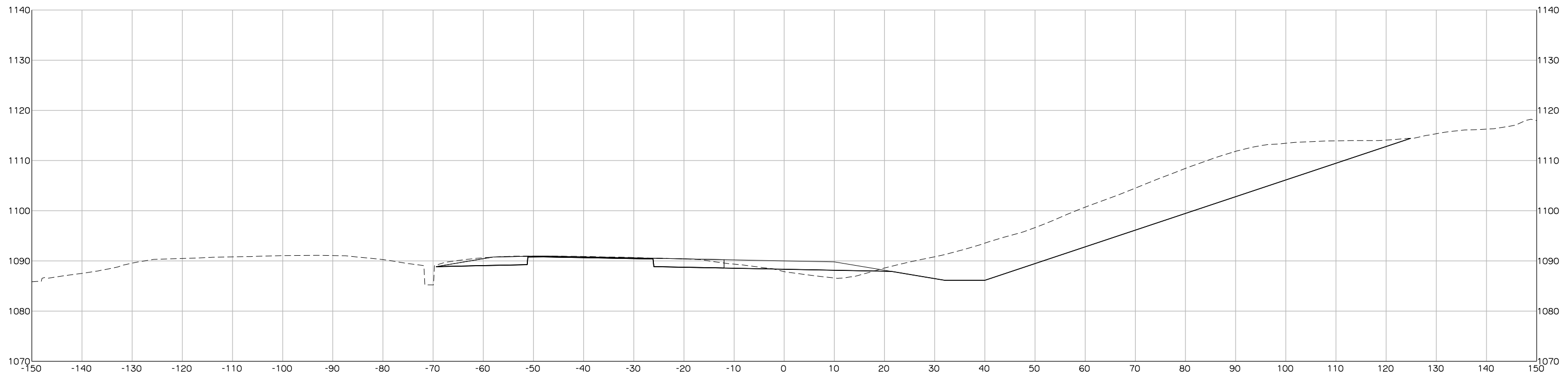

3017+00.00

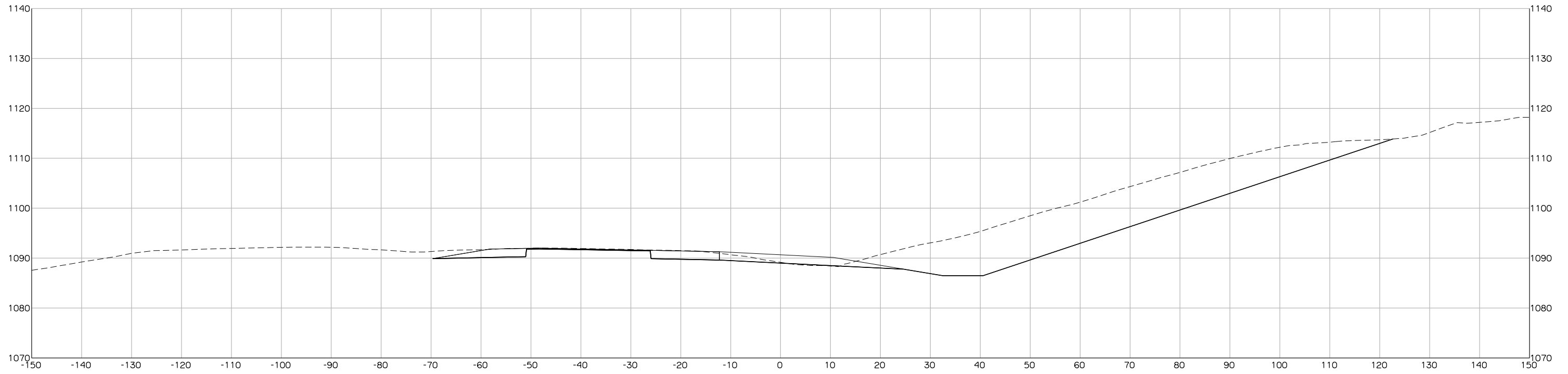

3019+00.00

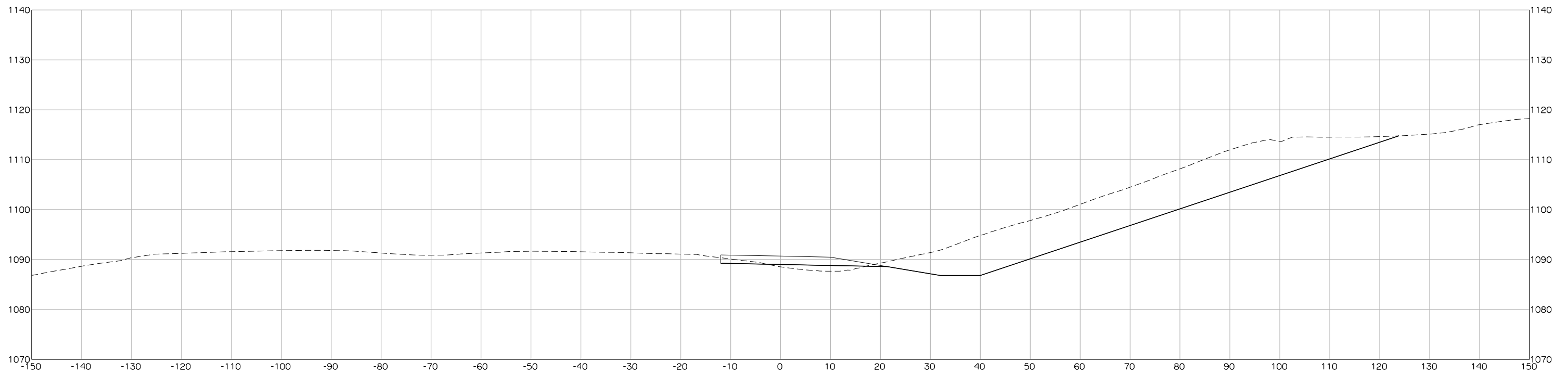

REVERSE CROSS SLOPE
3018+29.56

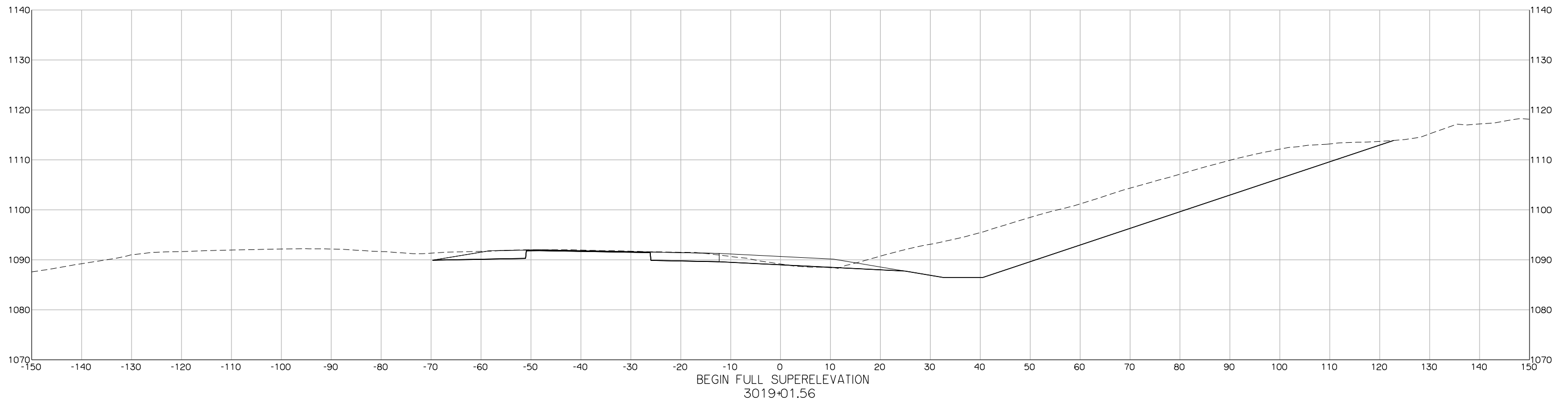
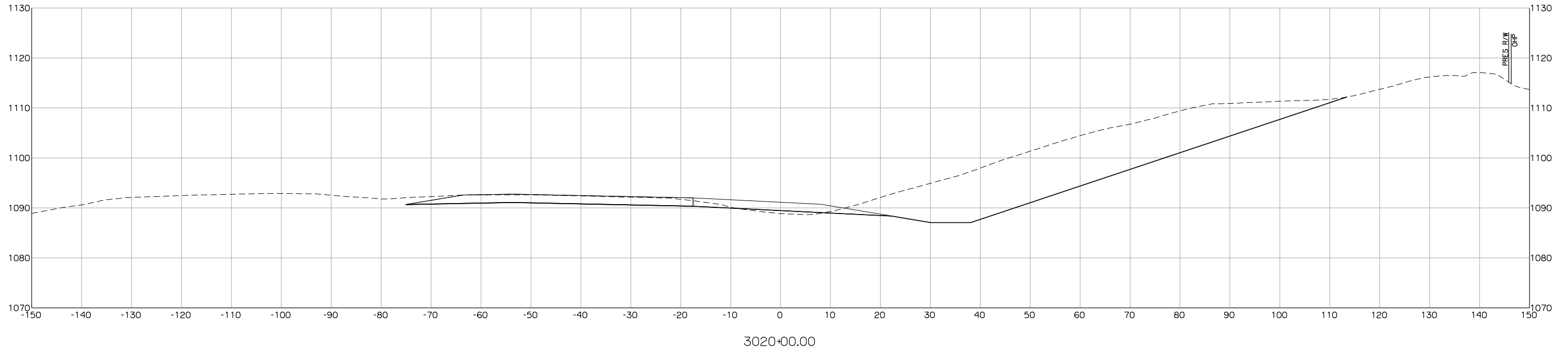

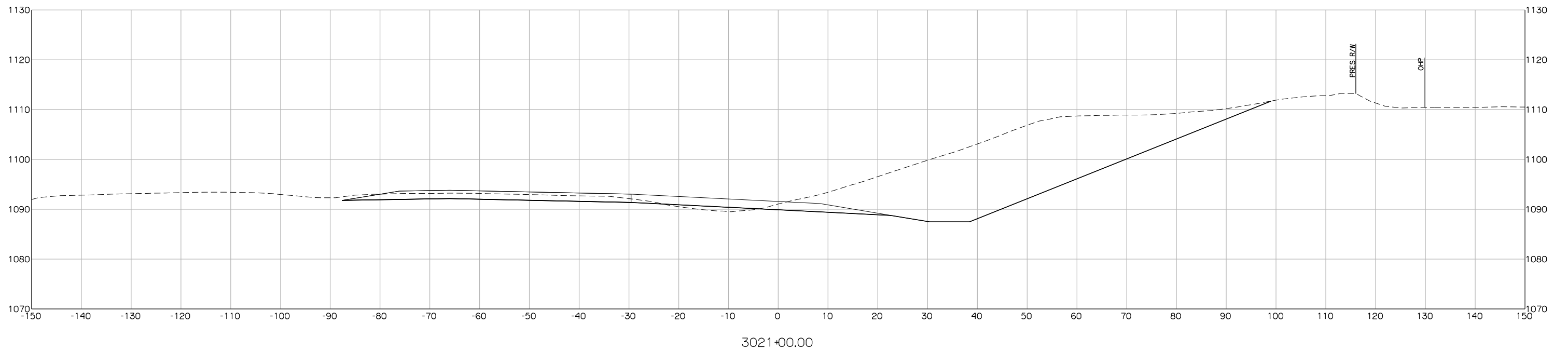
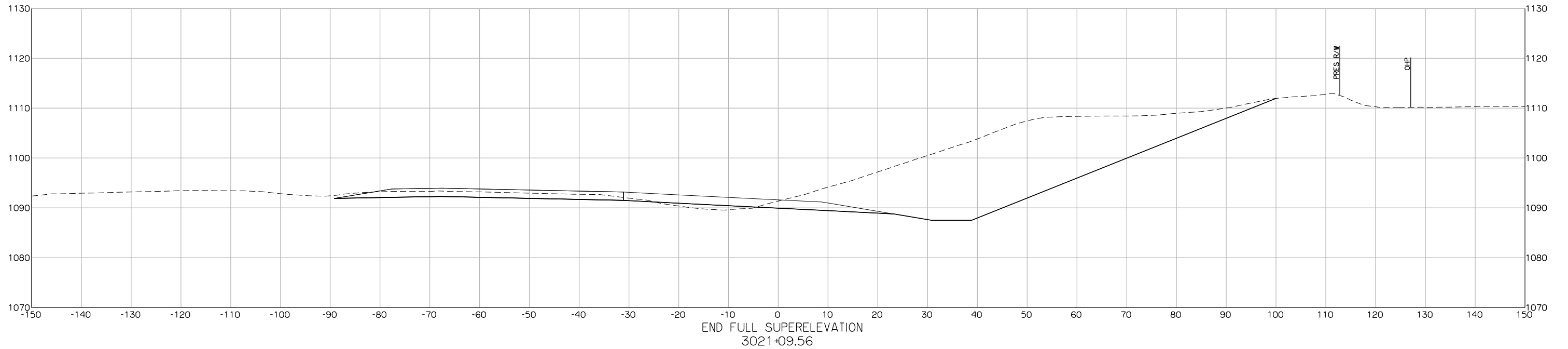

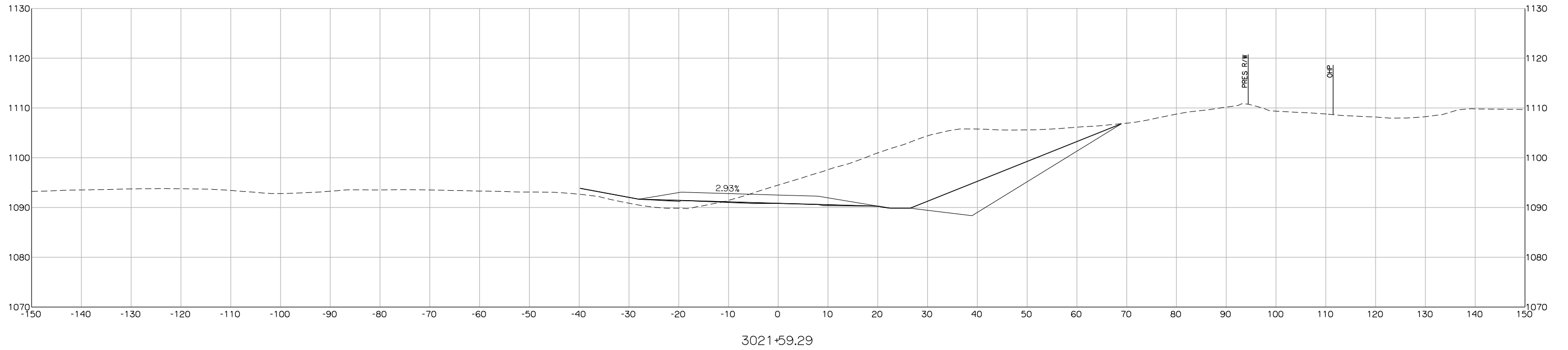

3021+59.29

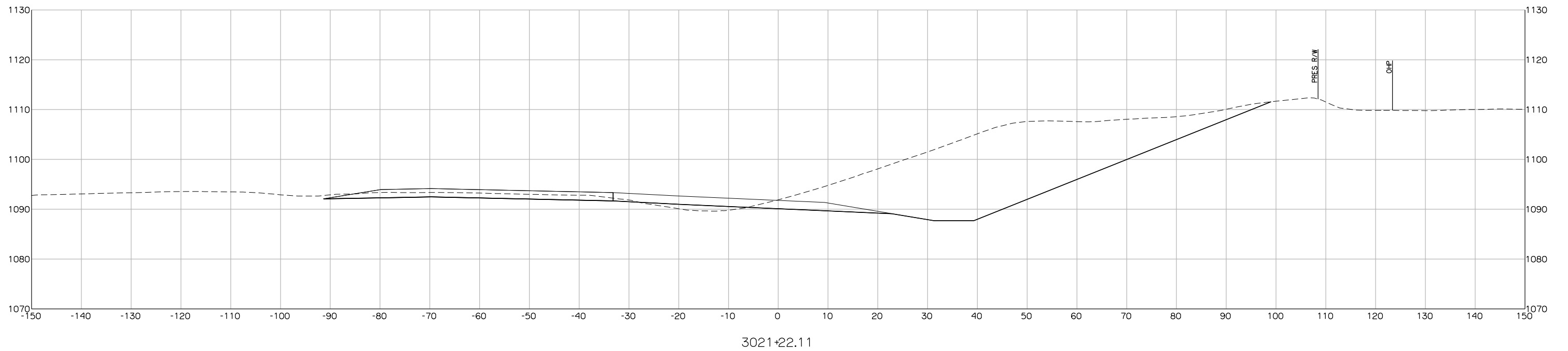

3021+22.11

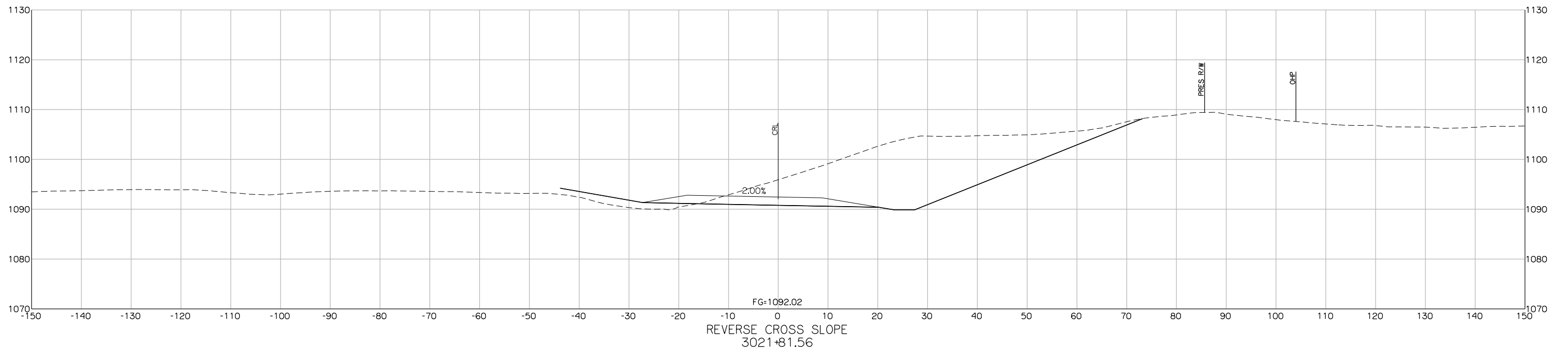
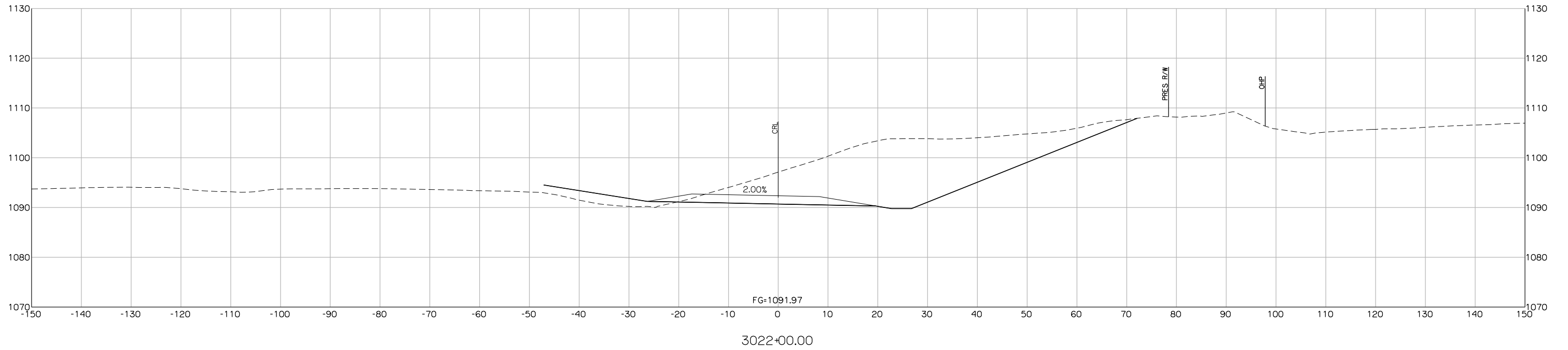

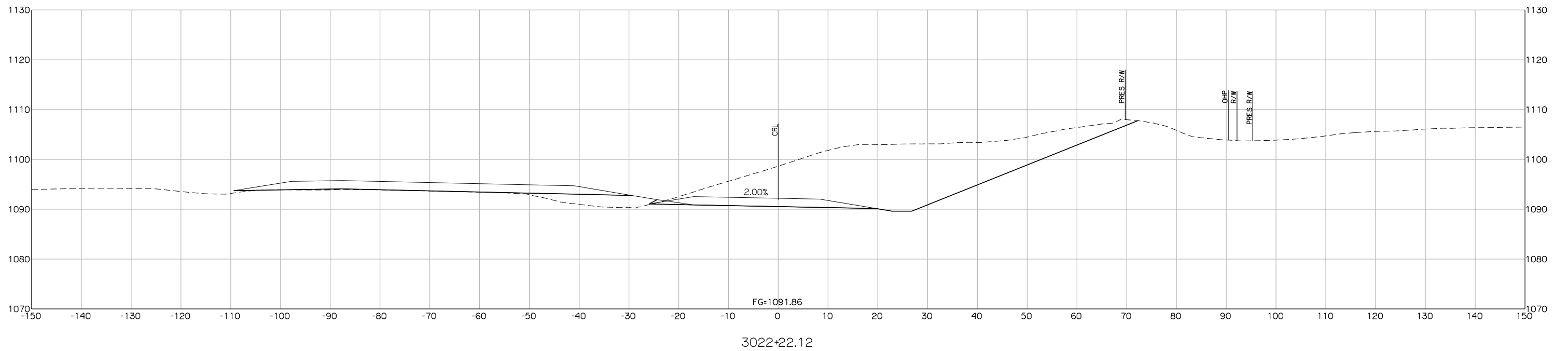
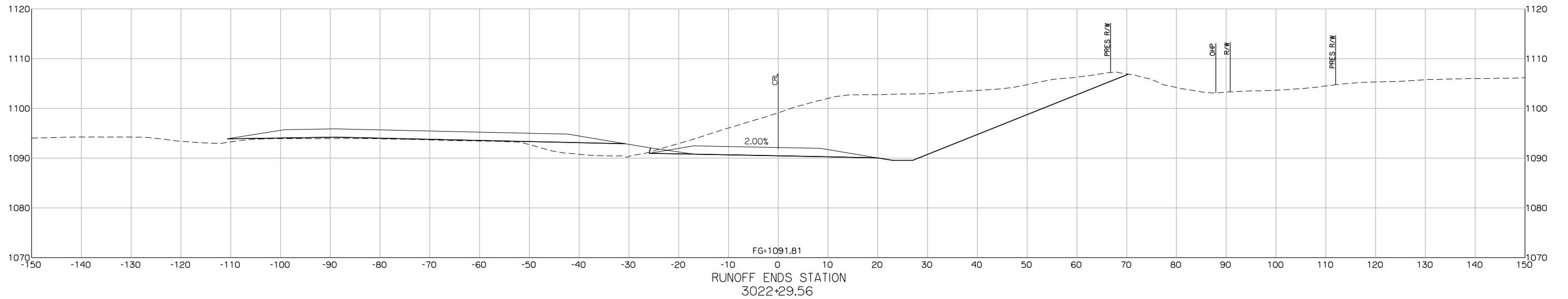

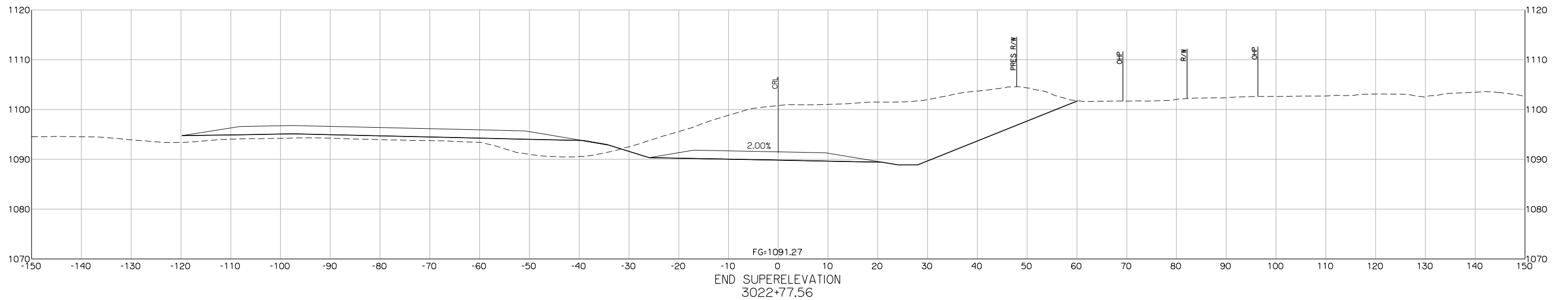
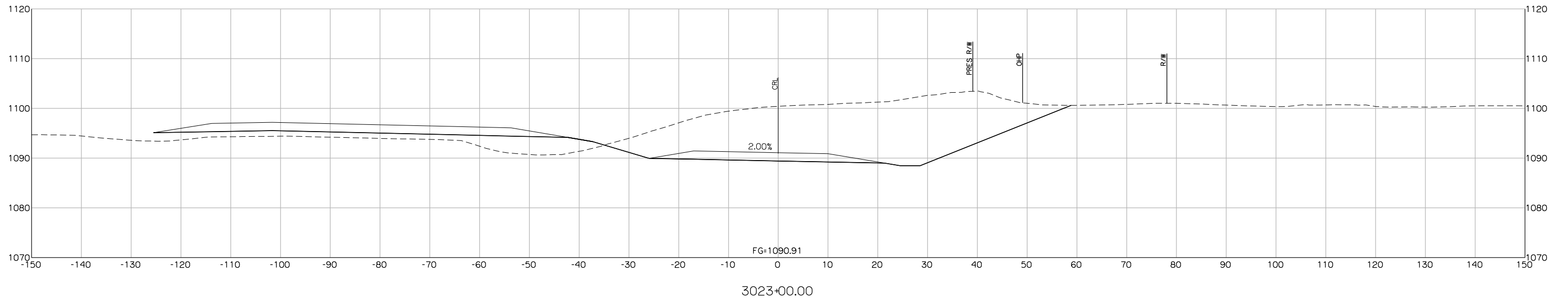
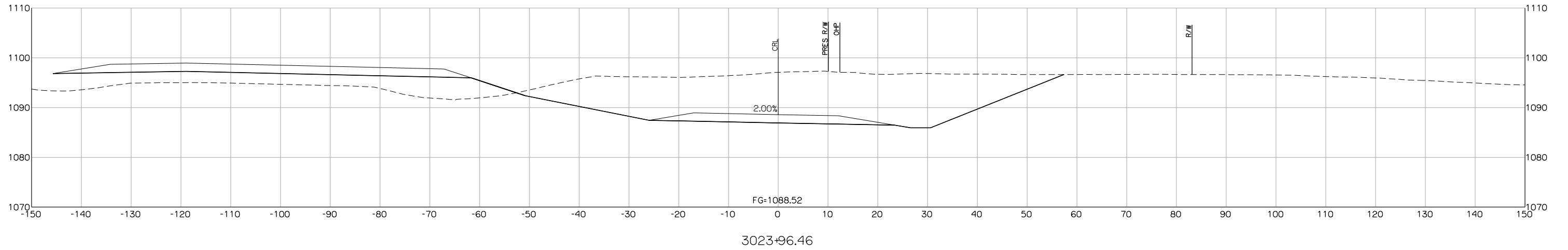

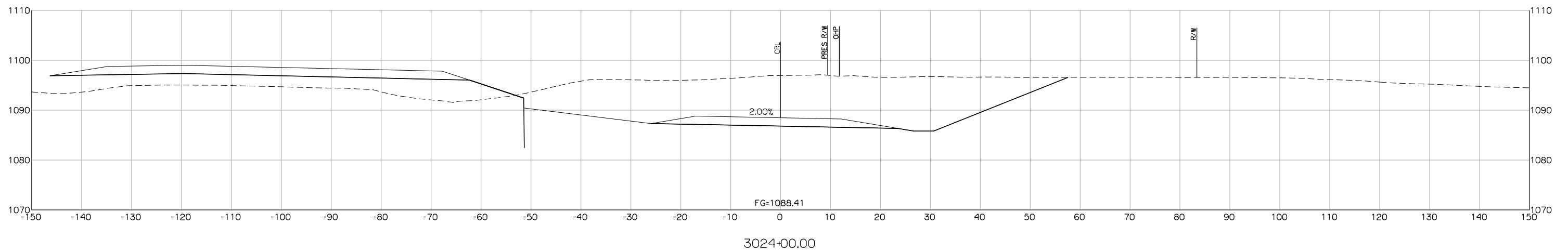
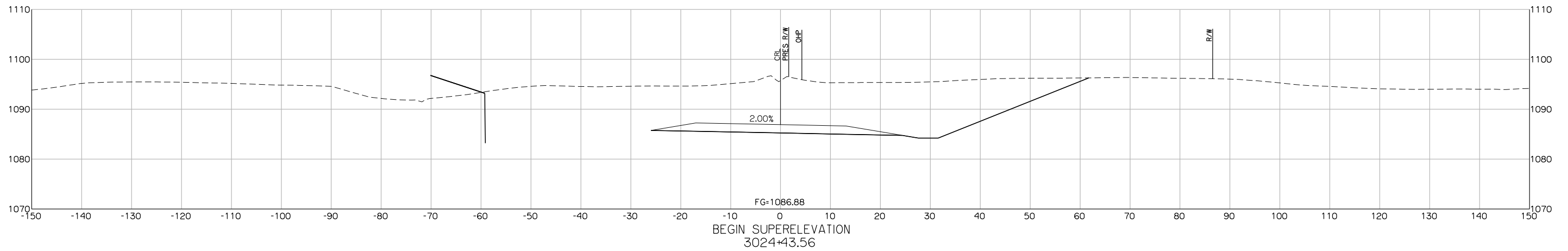
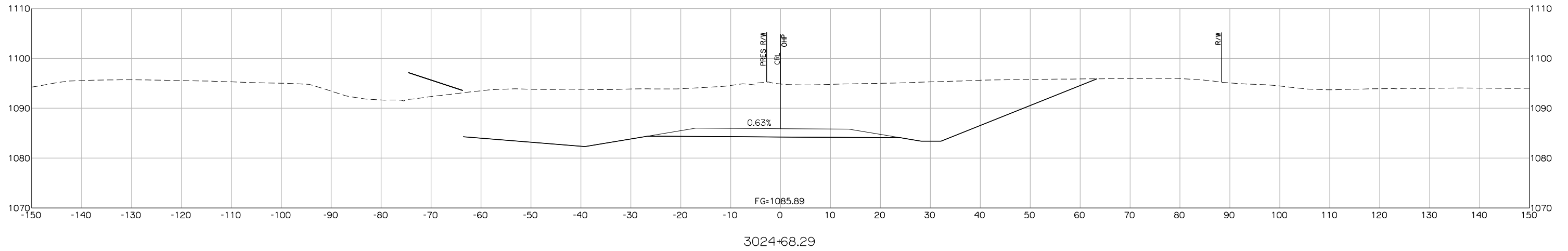

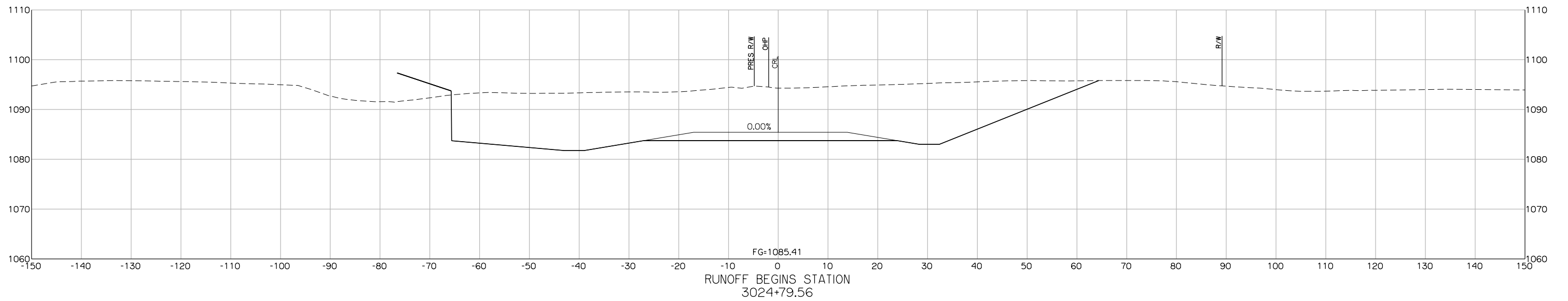
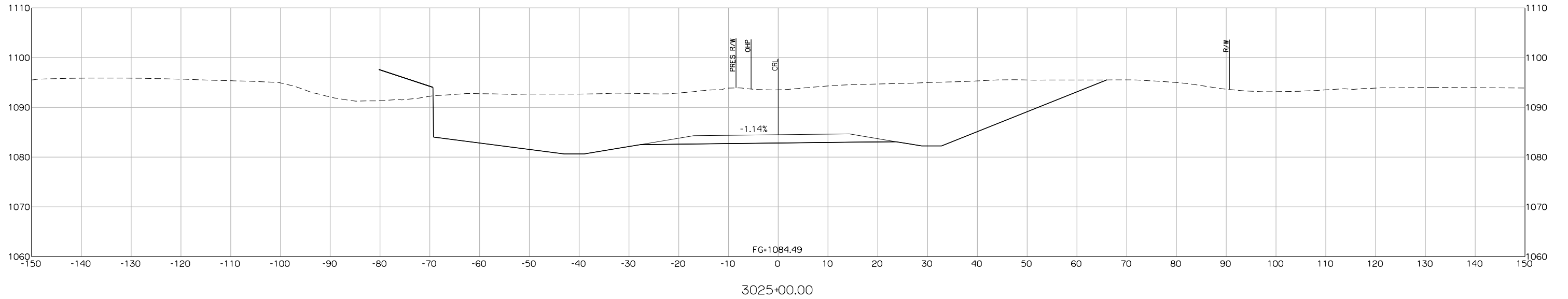

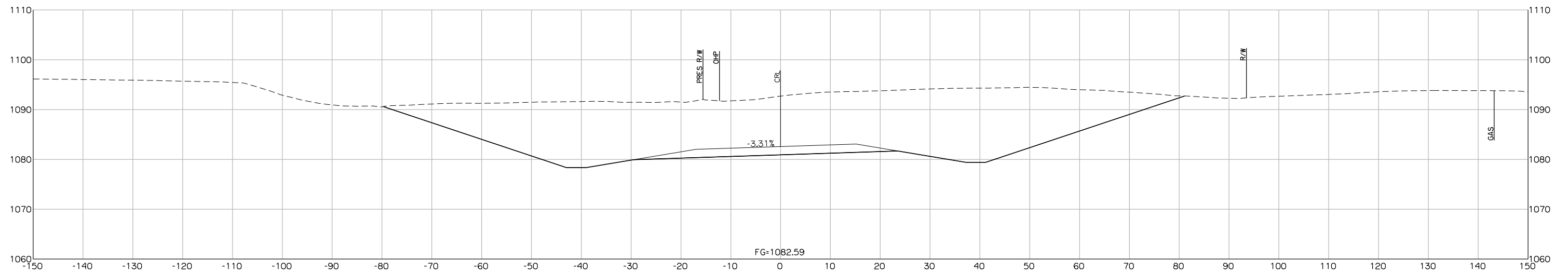

3025+39.56

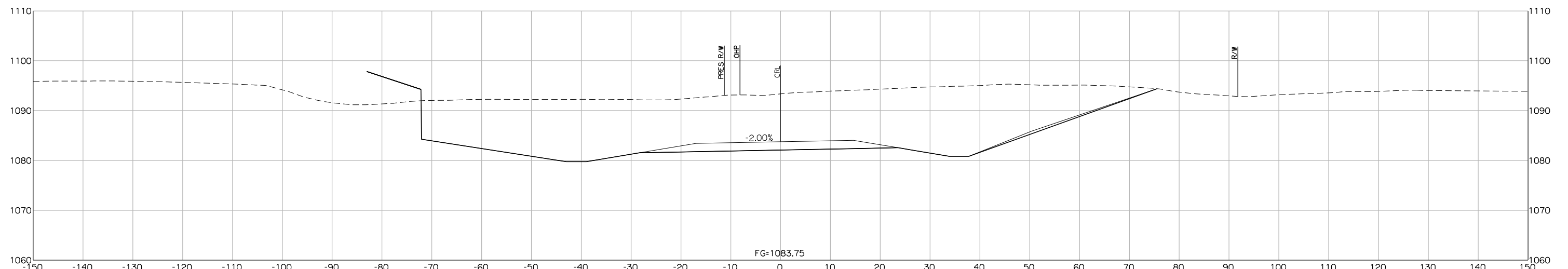

REVERSE CROSS SLOPE
3025+15.56

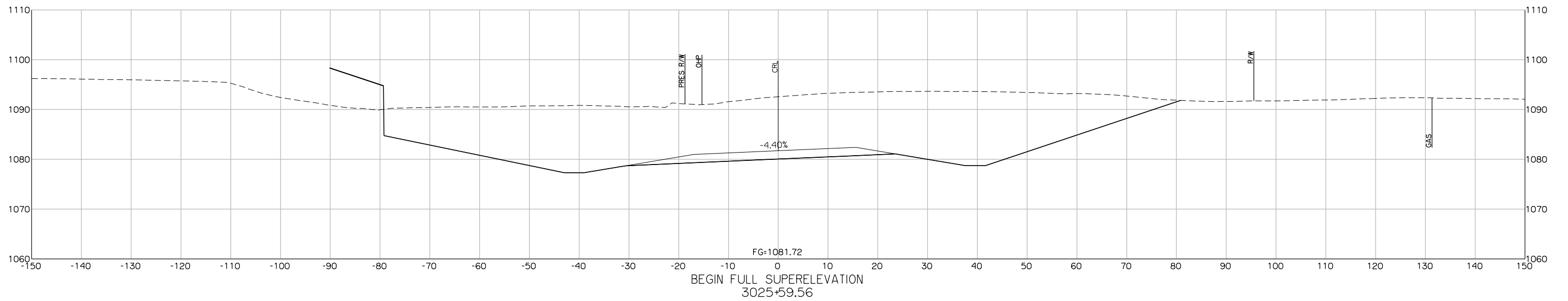
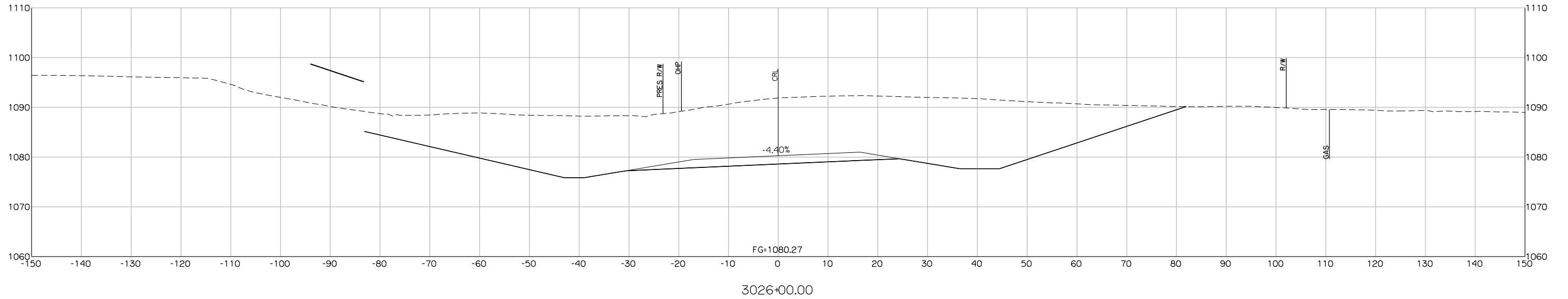

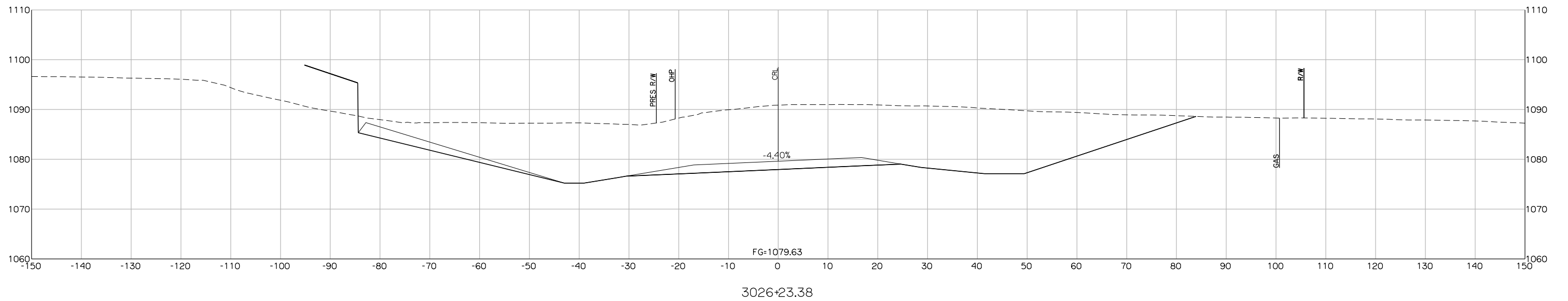
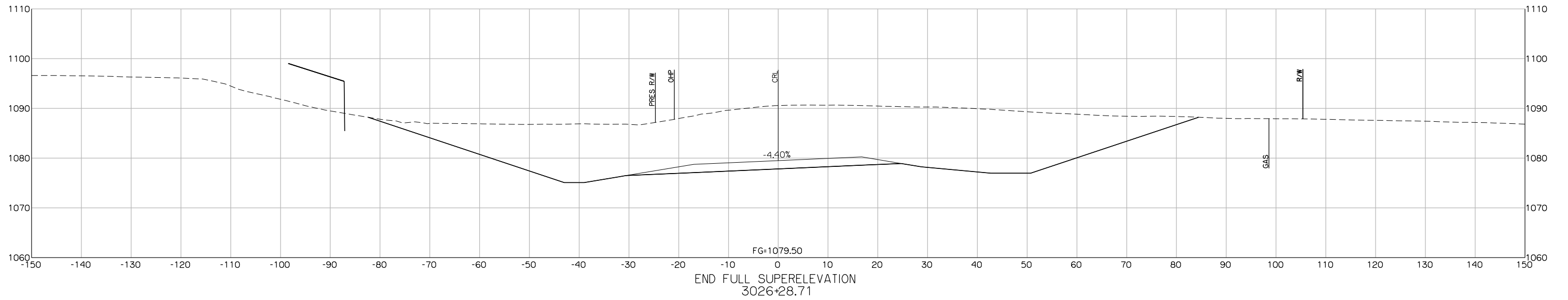

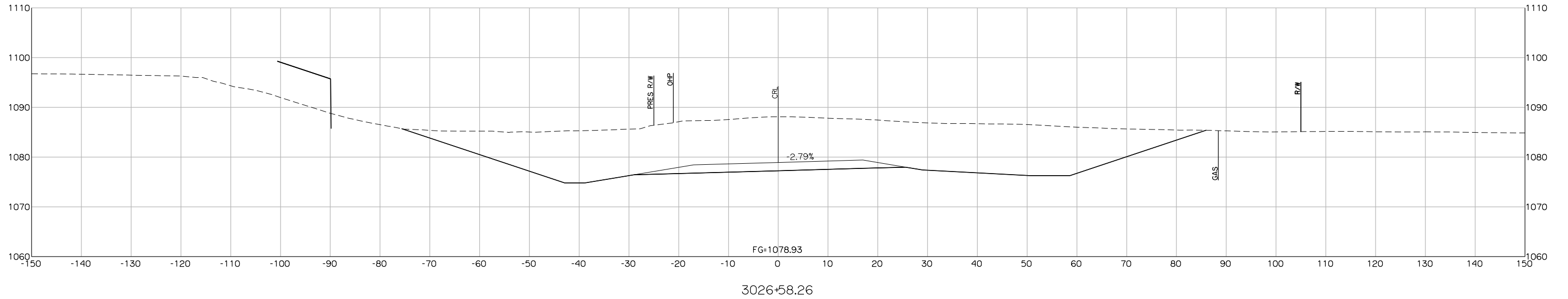

3026+58.26

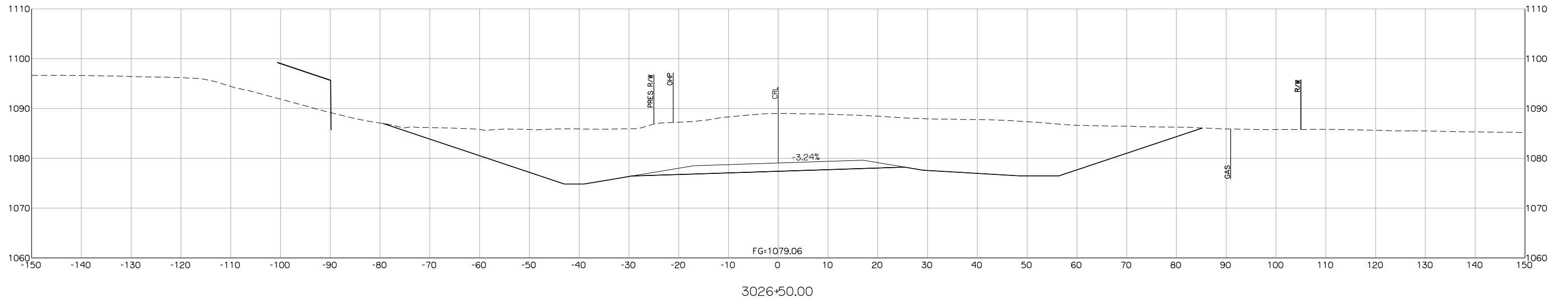

3026+50.00

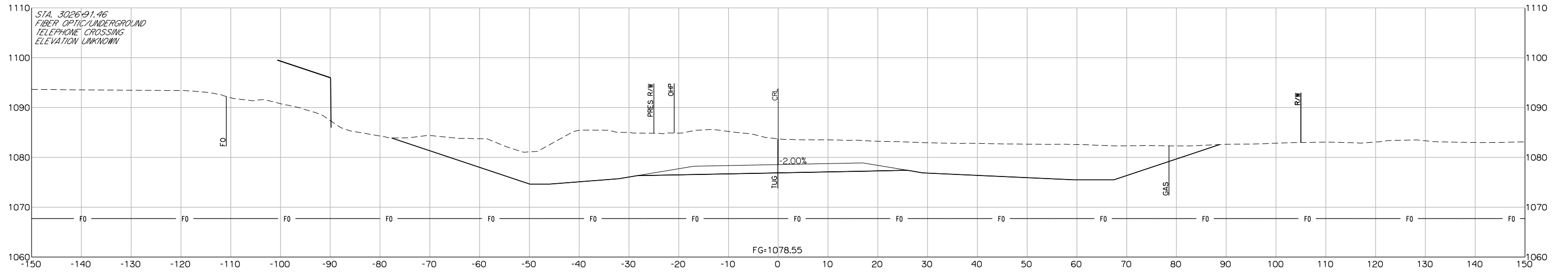

3026+91.46

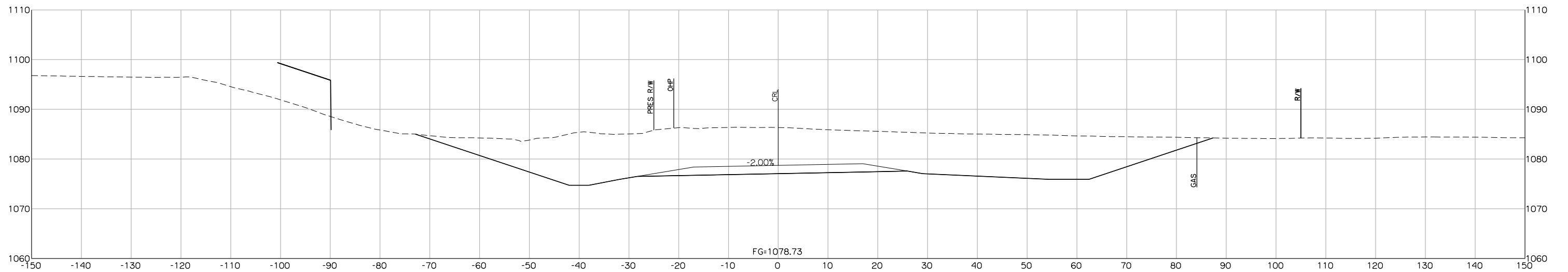

REVERSE CROSS SLOPE
3026+72.71

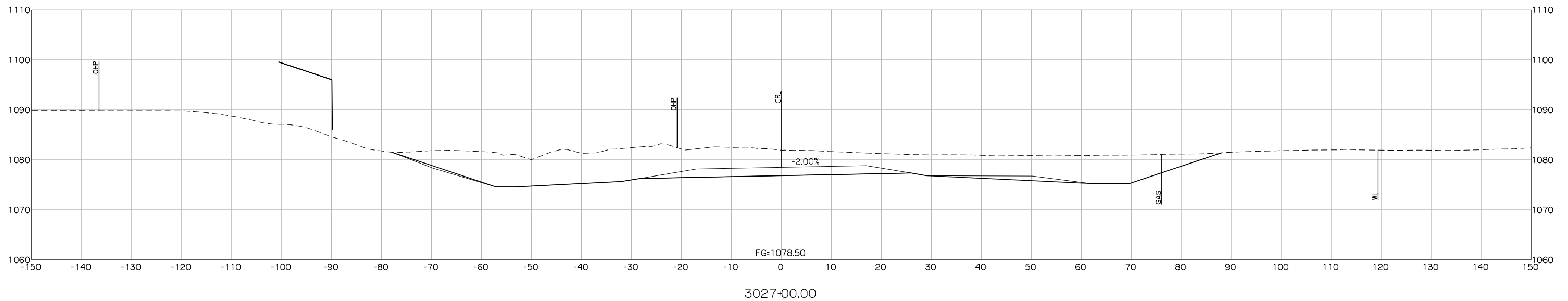
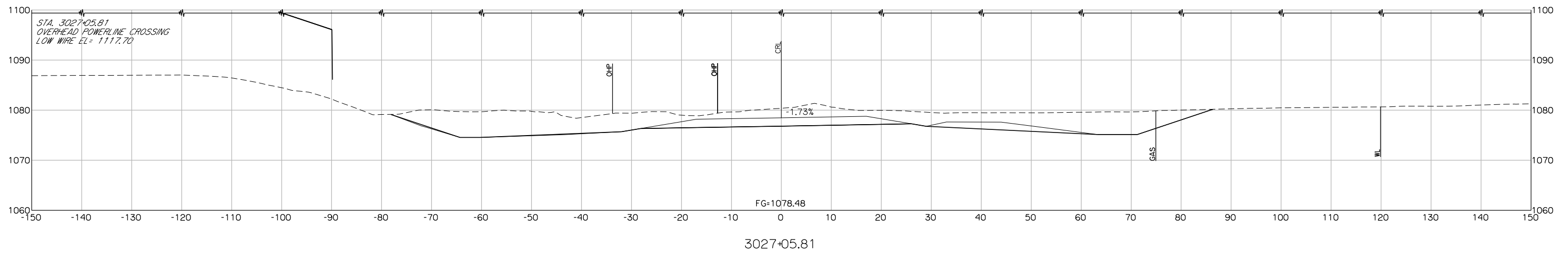
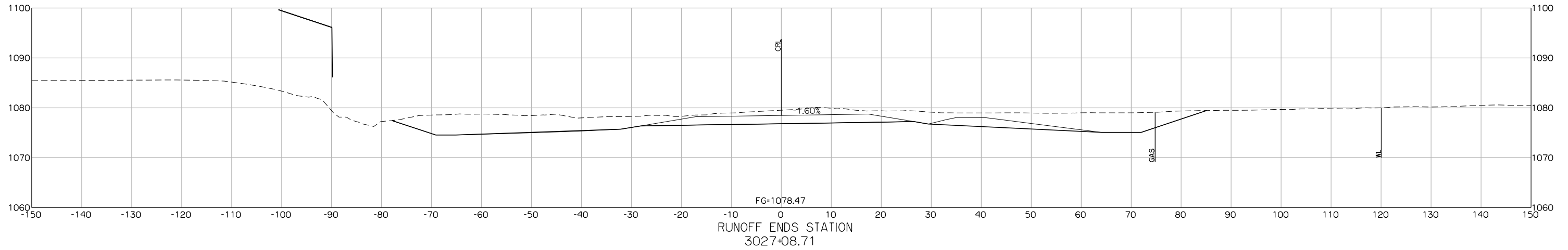

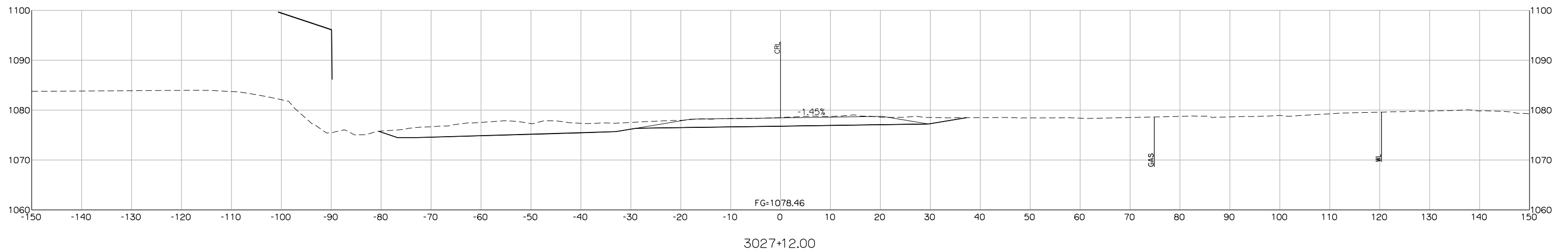
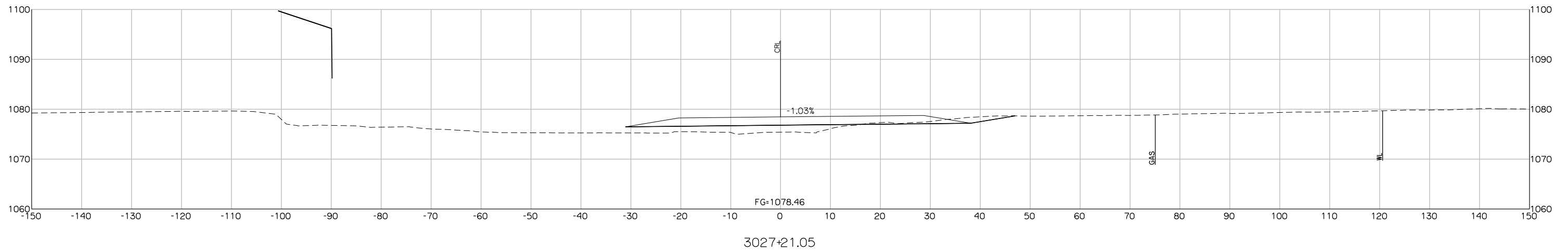
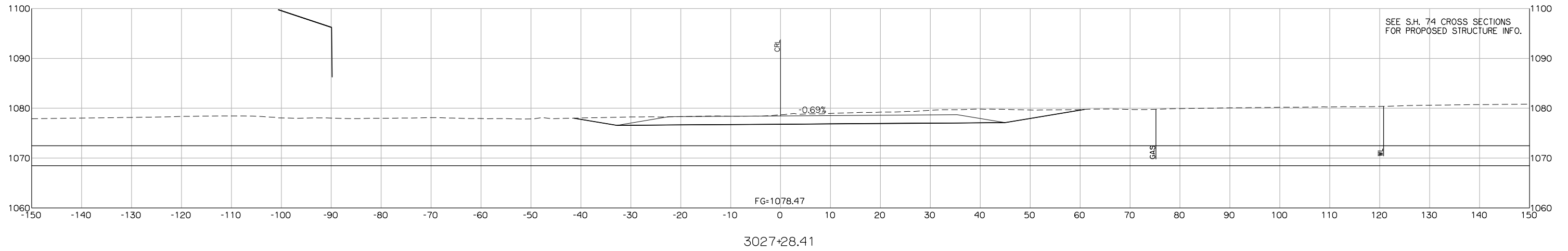

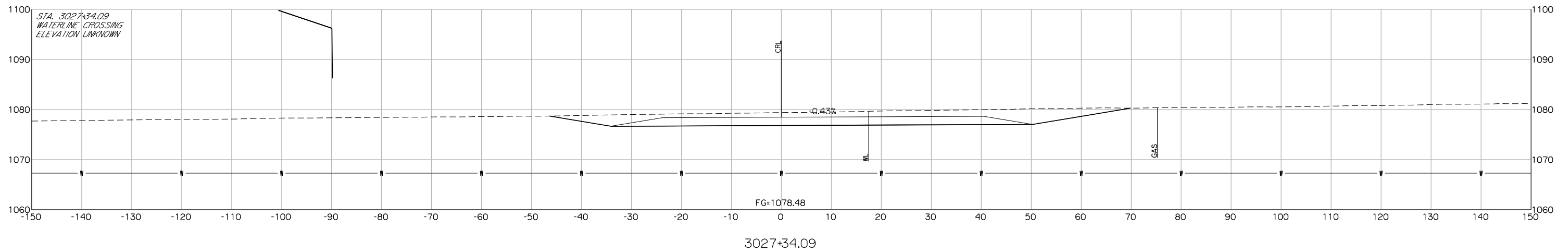
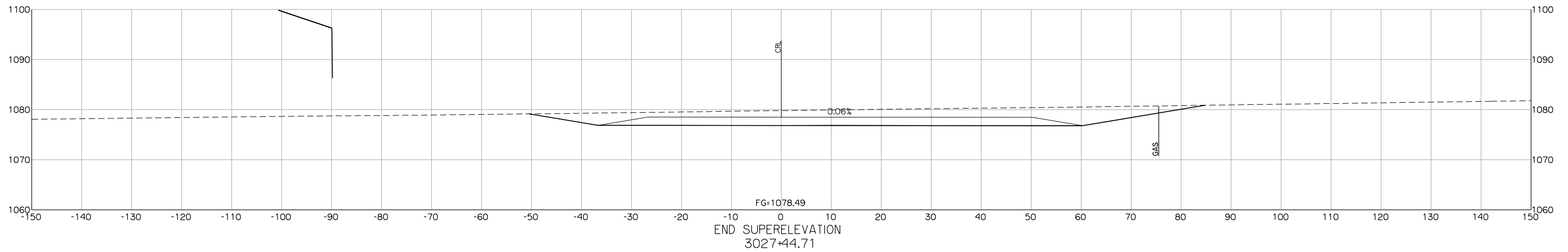
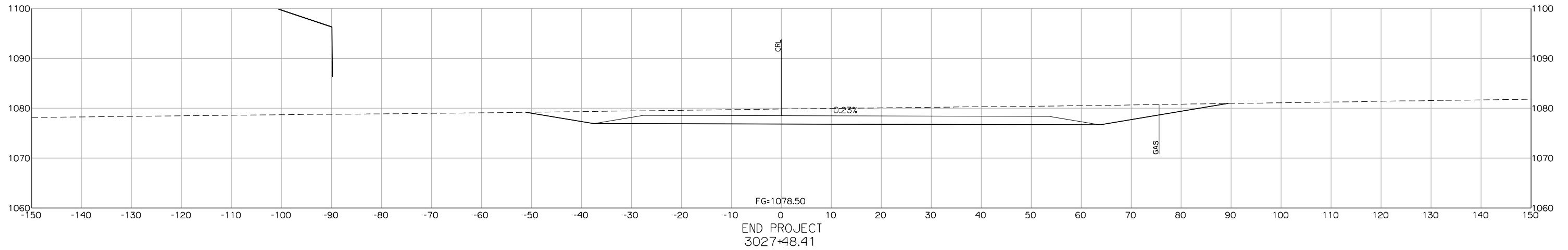

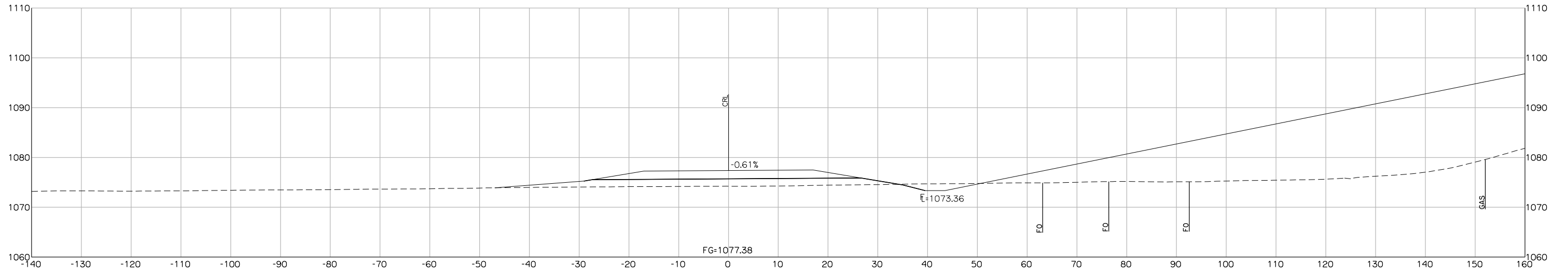

3027+54.49

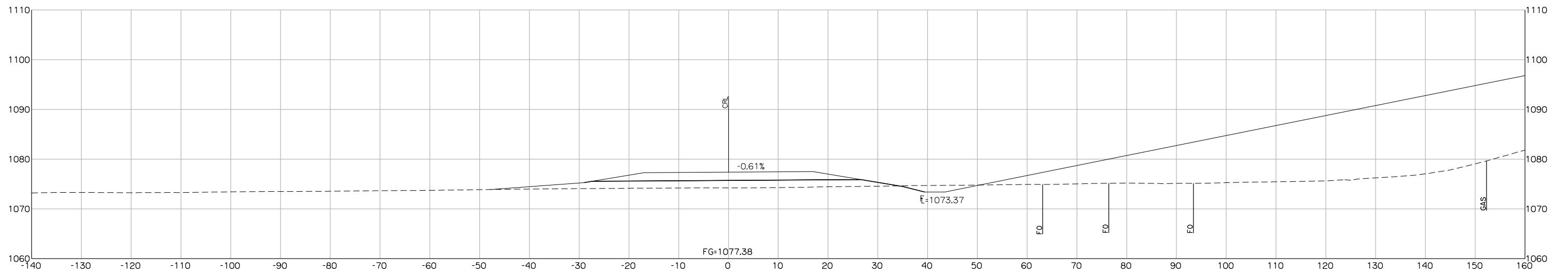

BEGIN PROJECT
3027+54.40

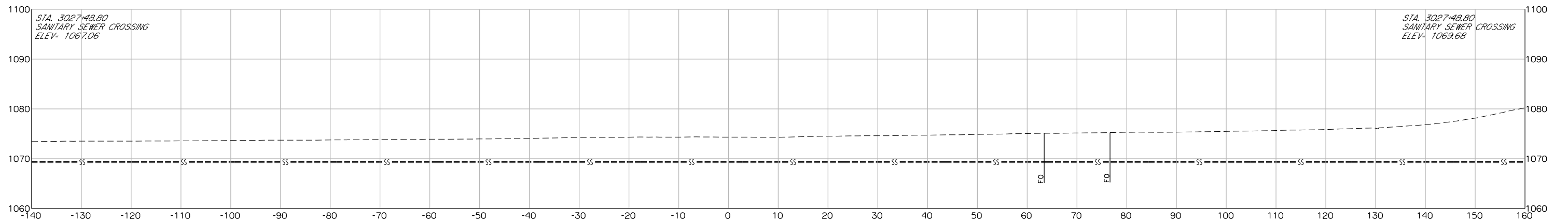

3027+48.80

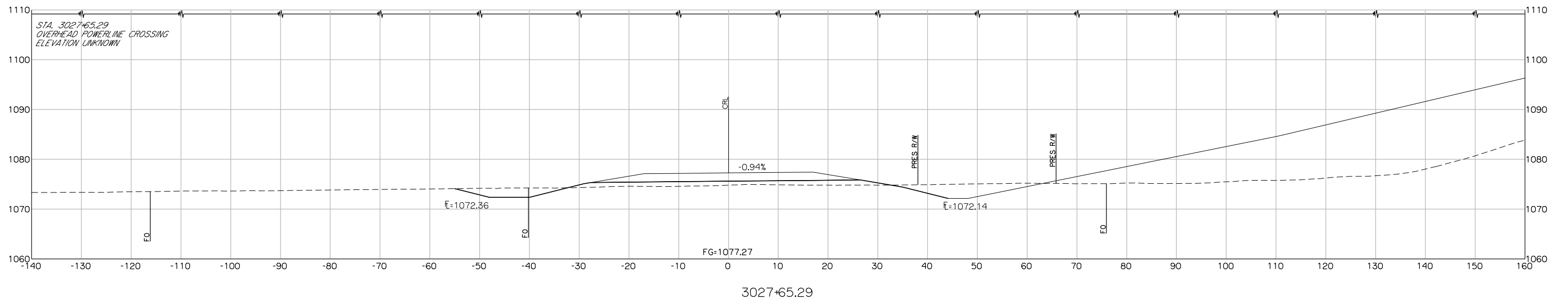
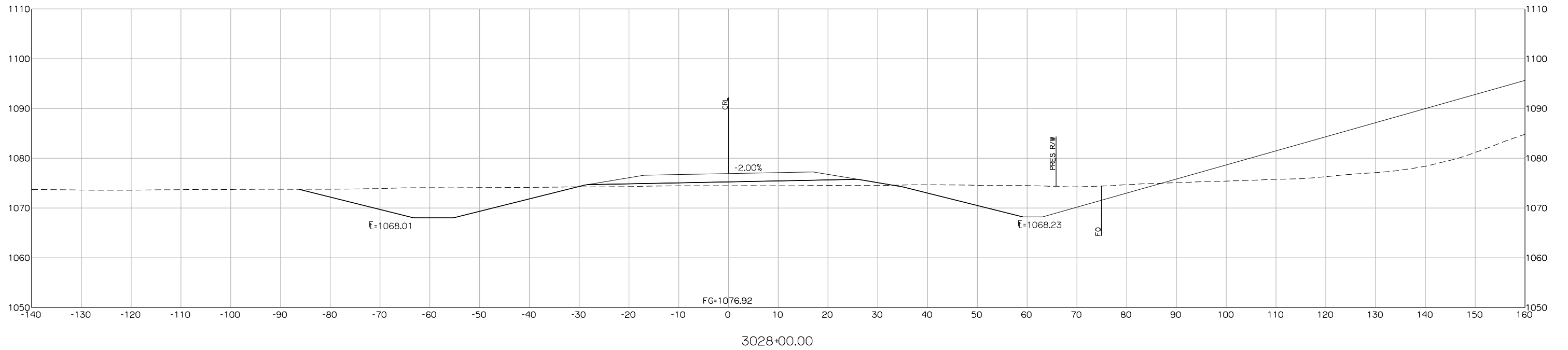

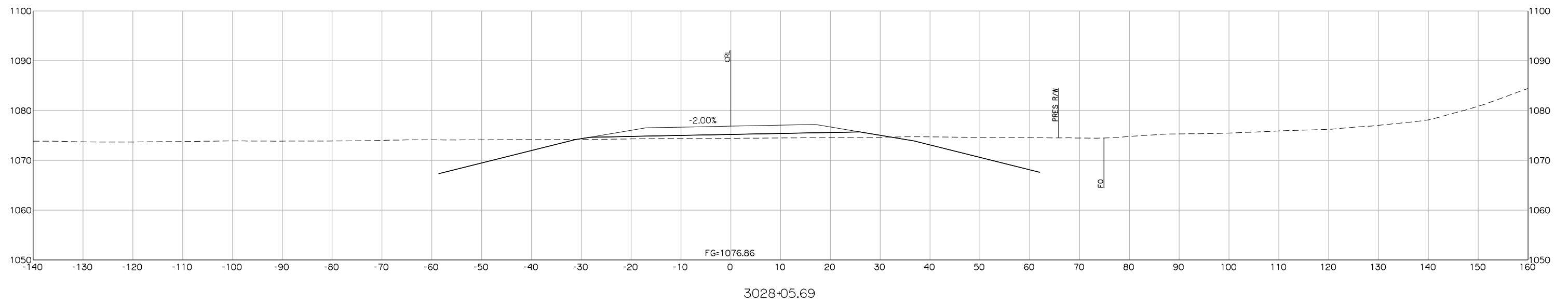
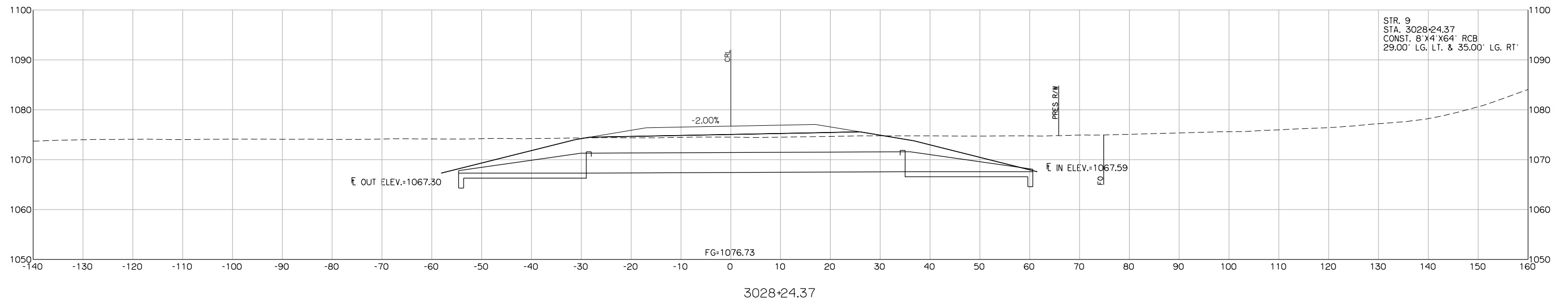

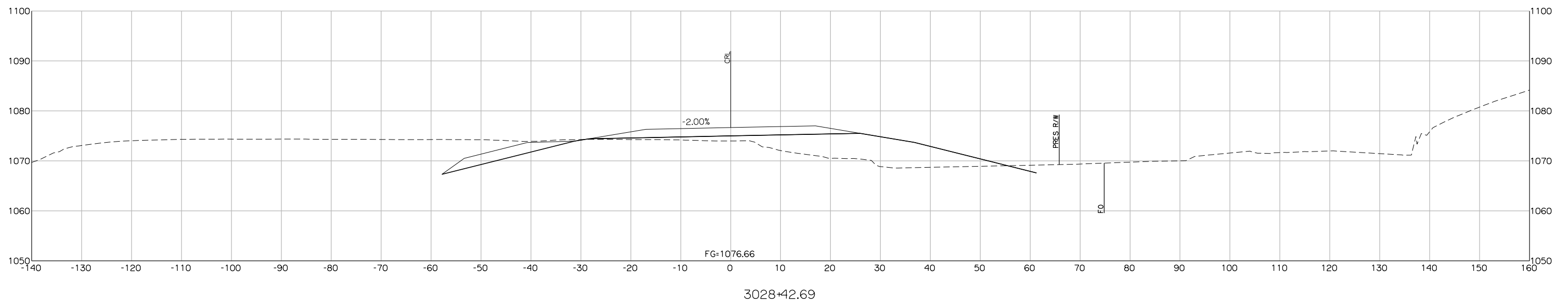
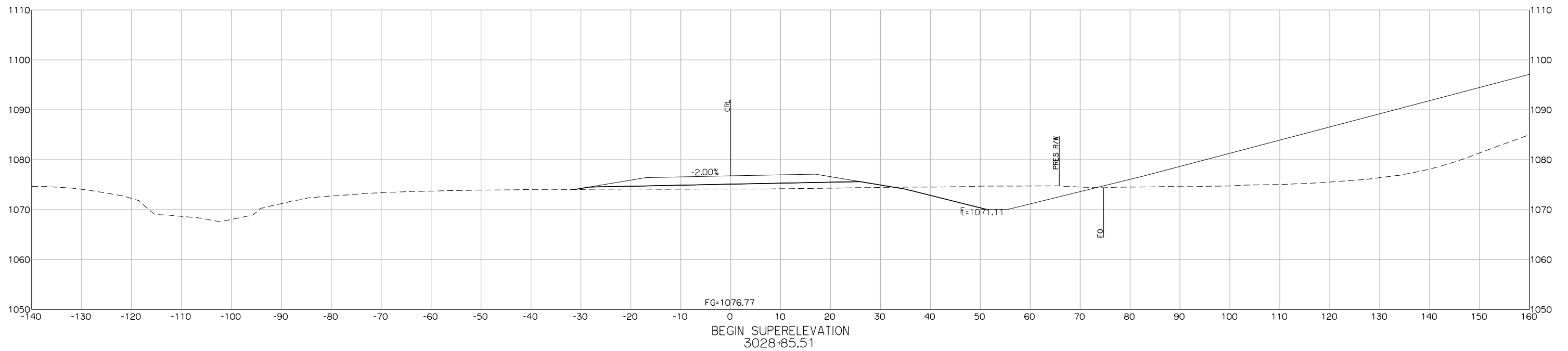

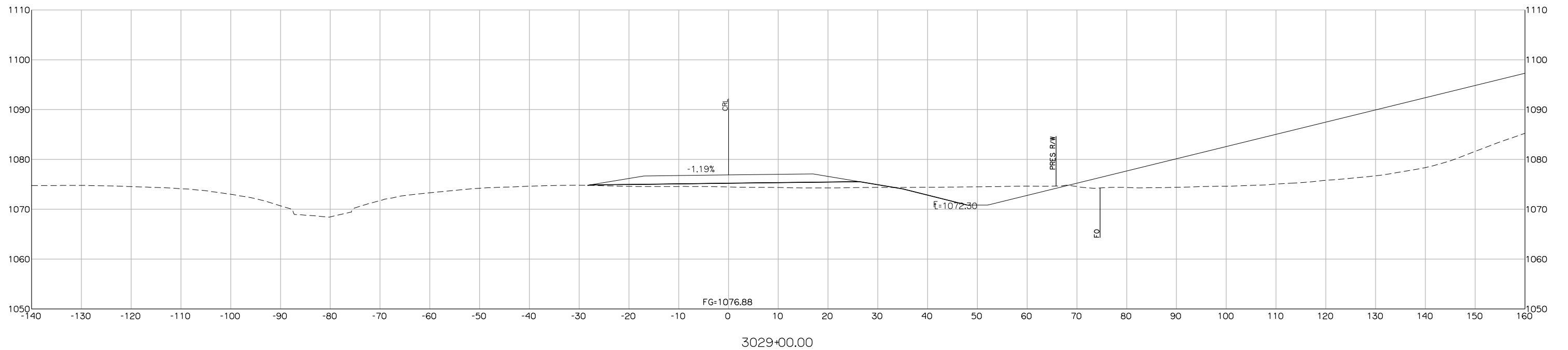
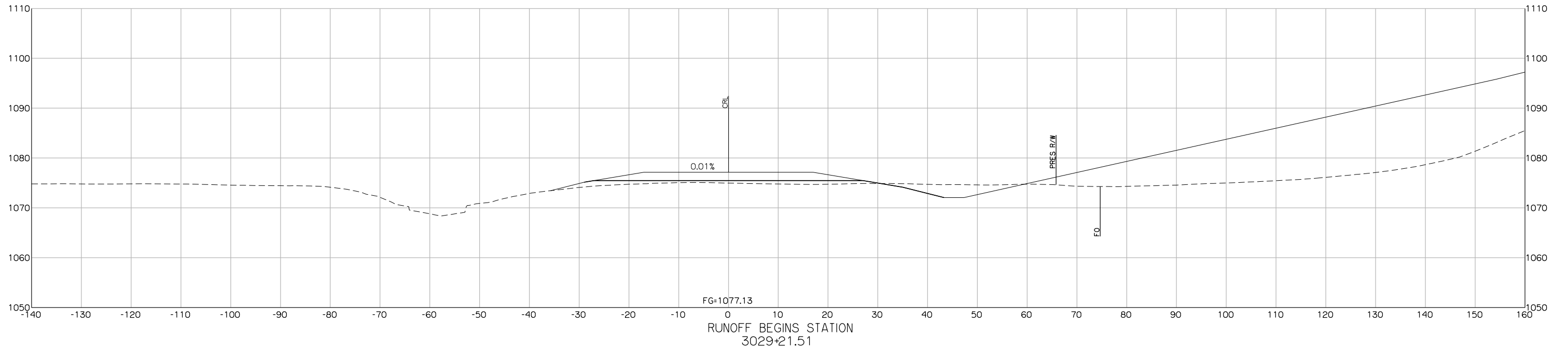

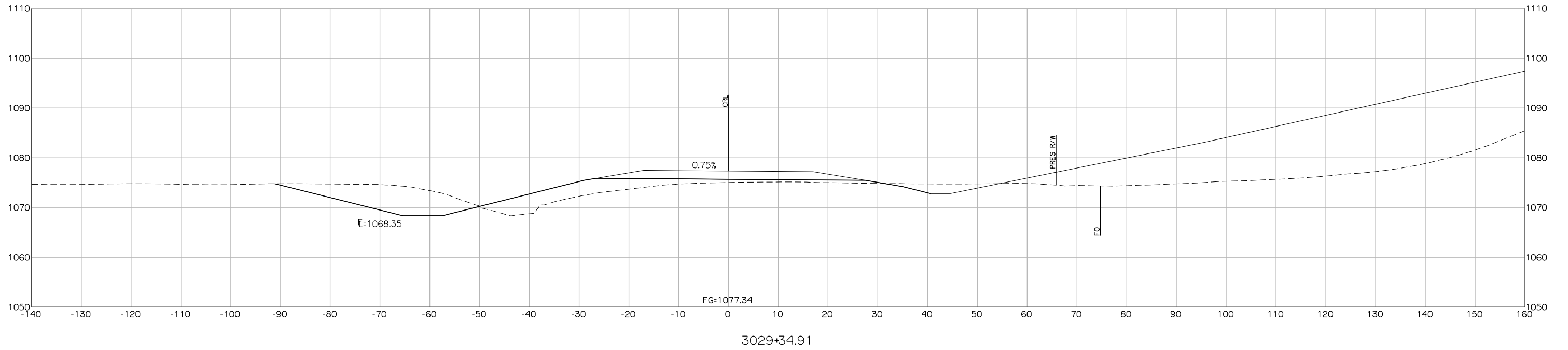

3029+34.91

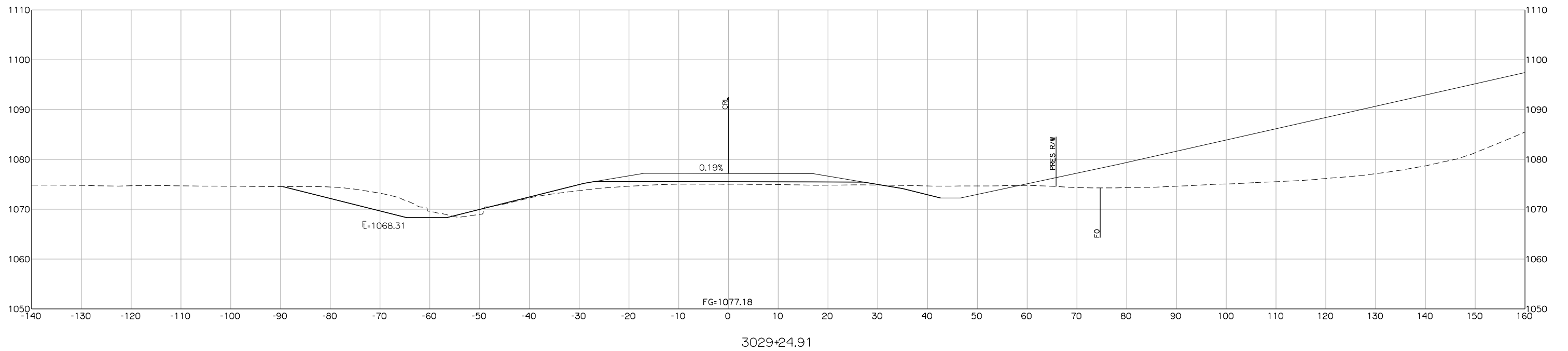

3029+24.91

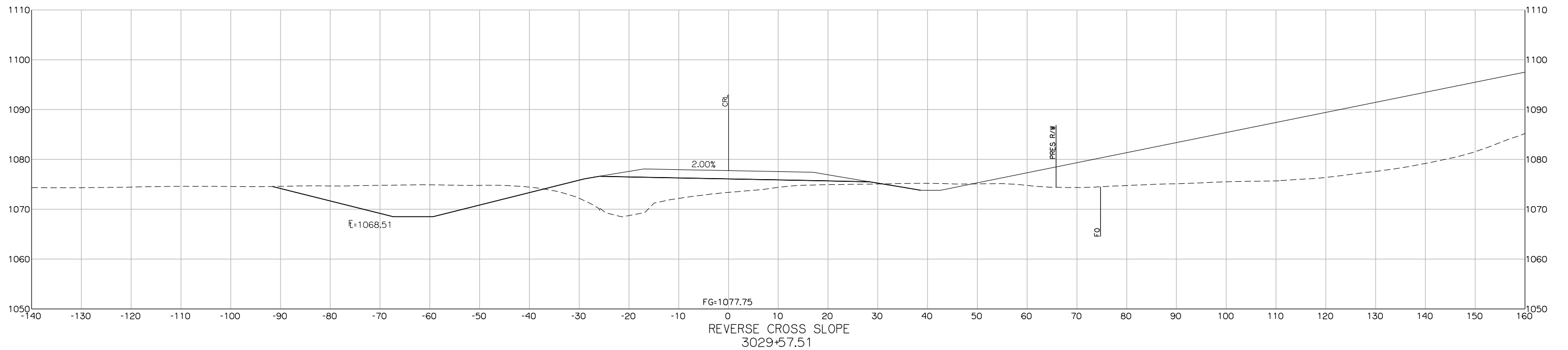
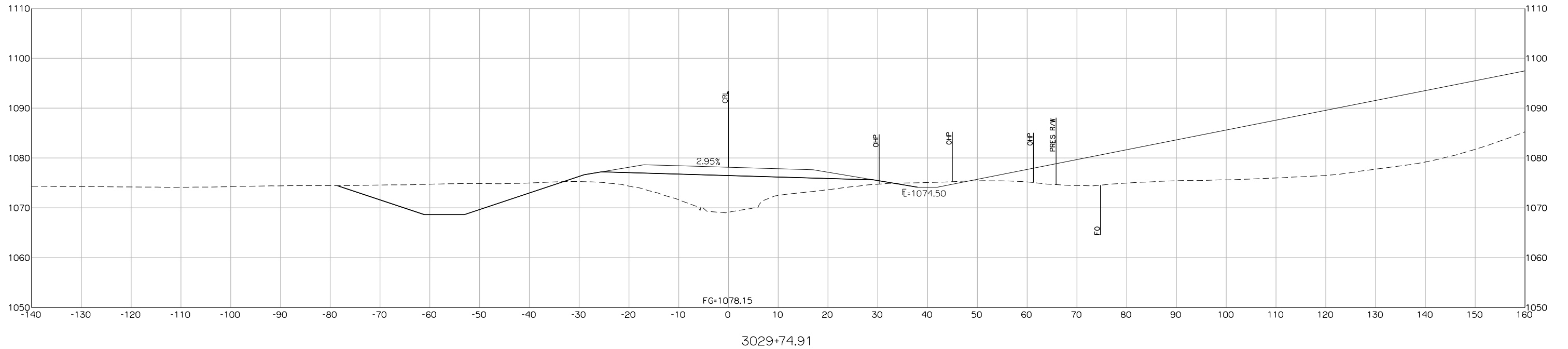

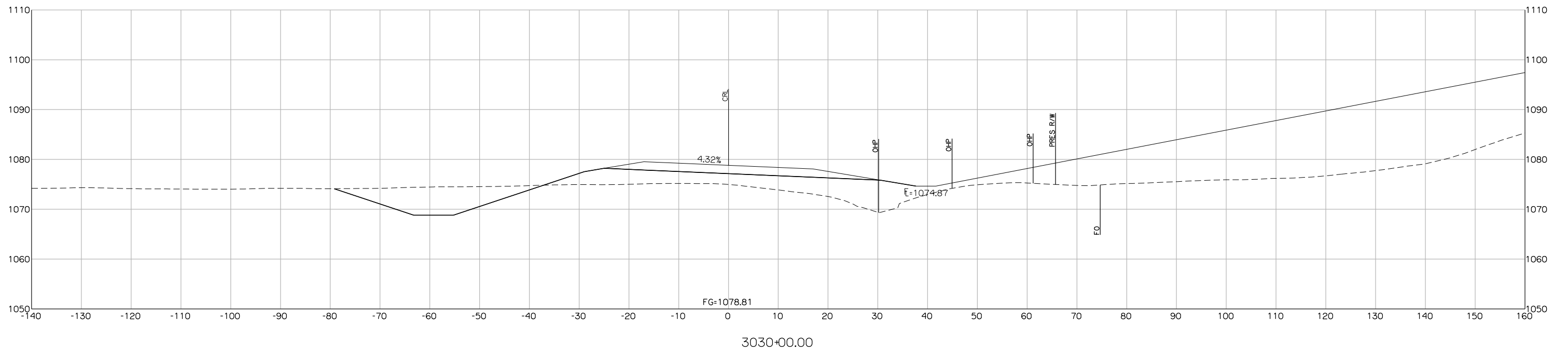
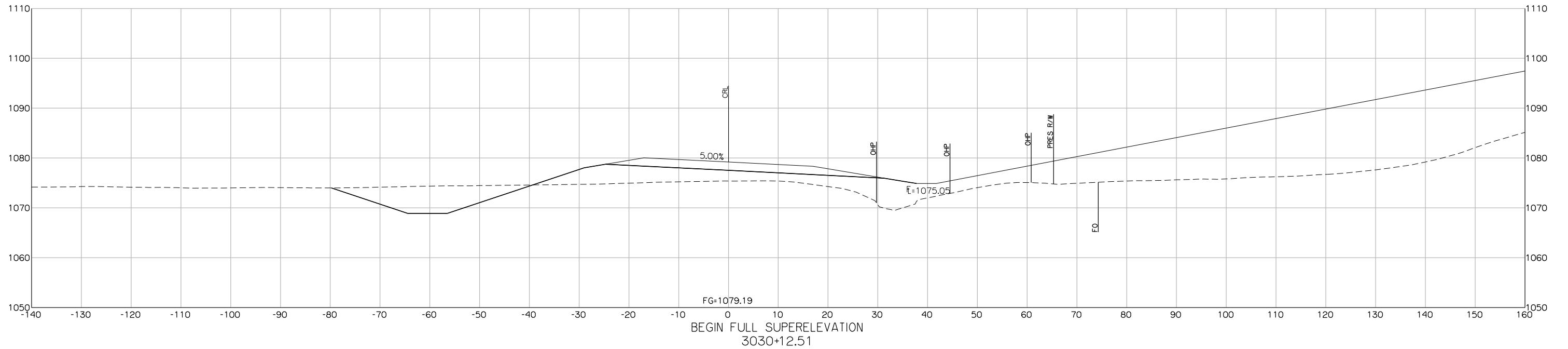

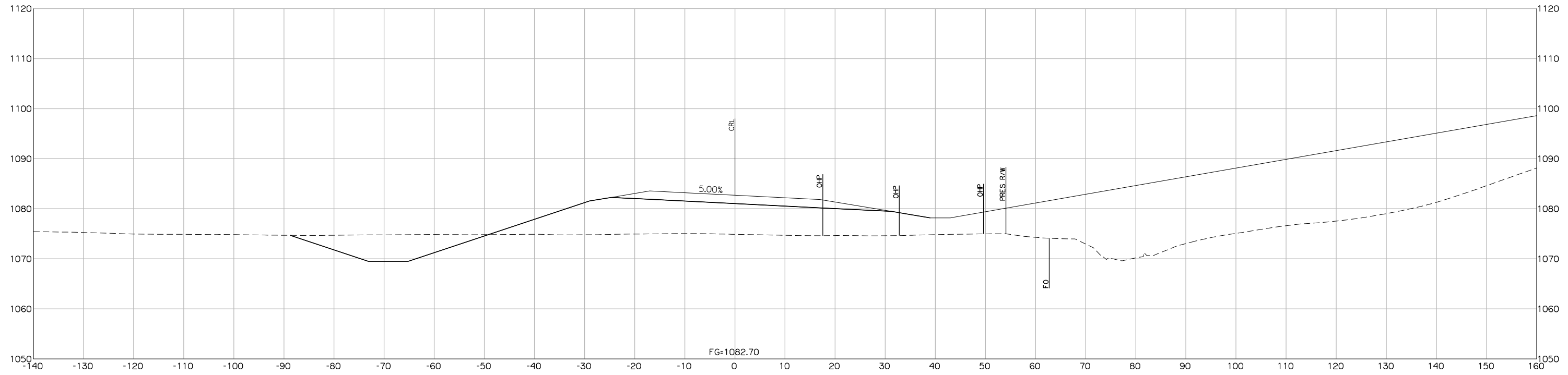

3031+00.00

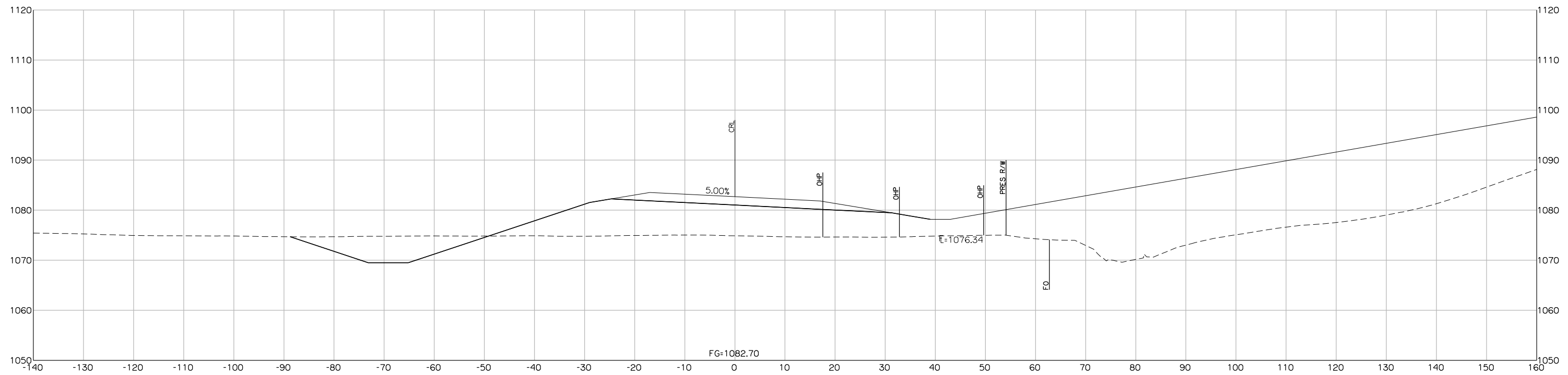

3030+99.91

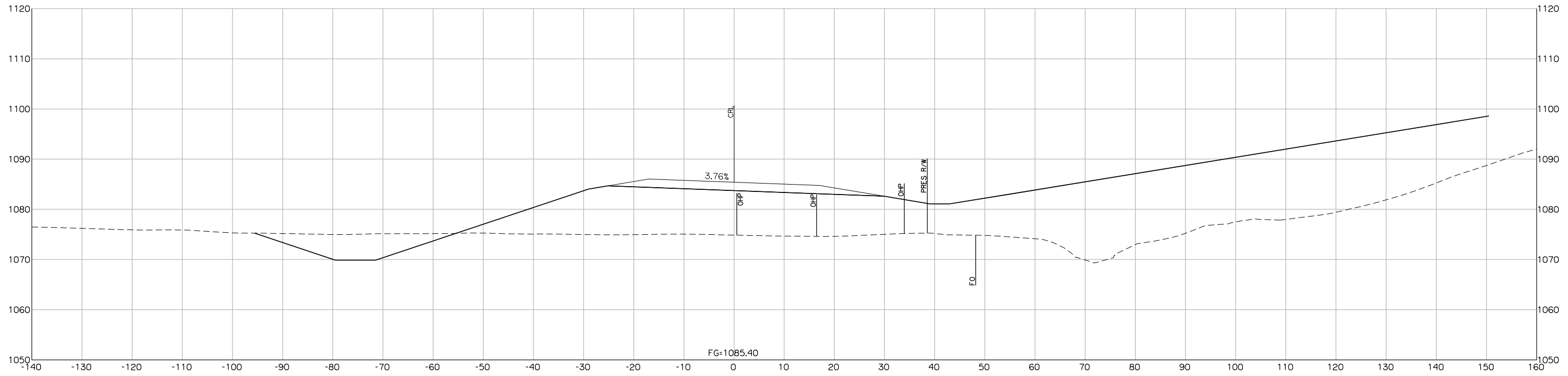

3031+55.46

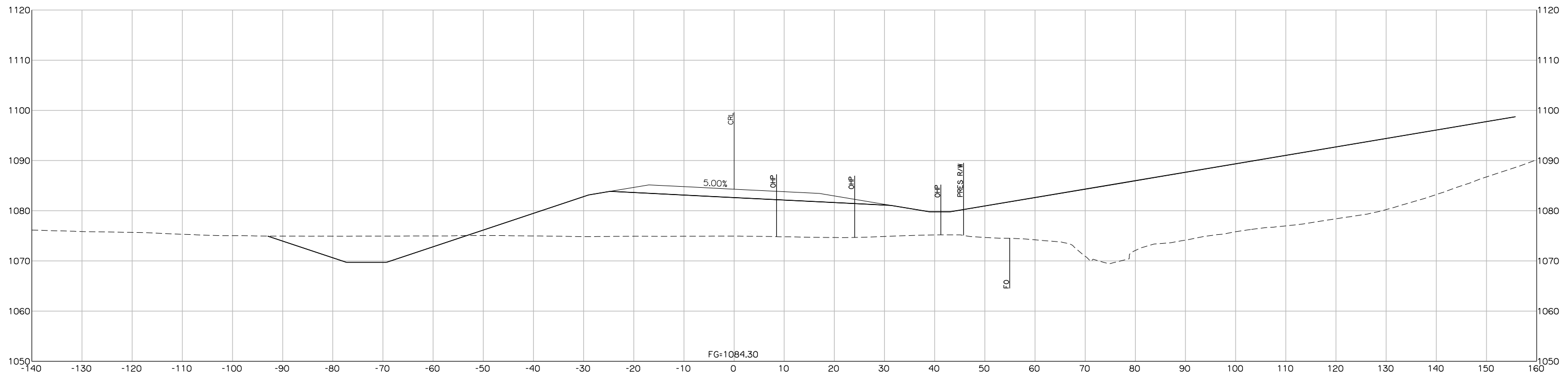

END FULL SUPERELEVATION
3031+32.80

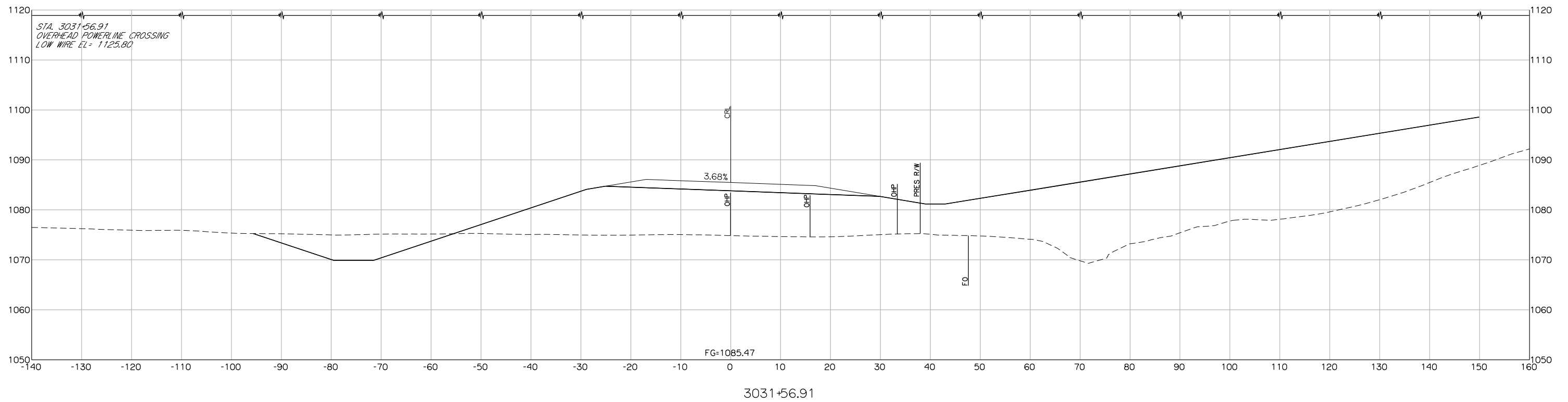
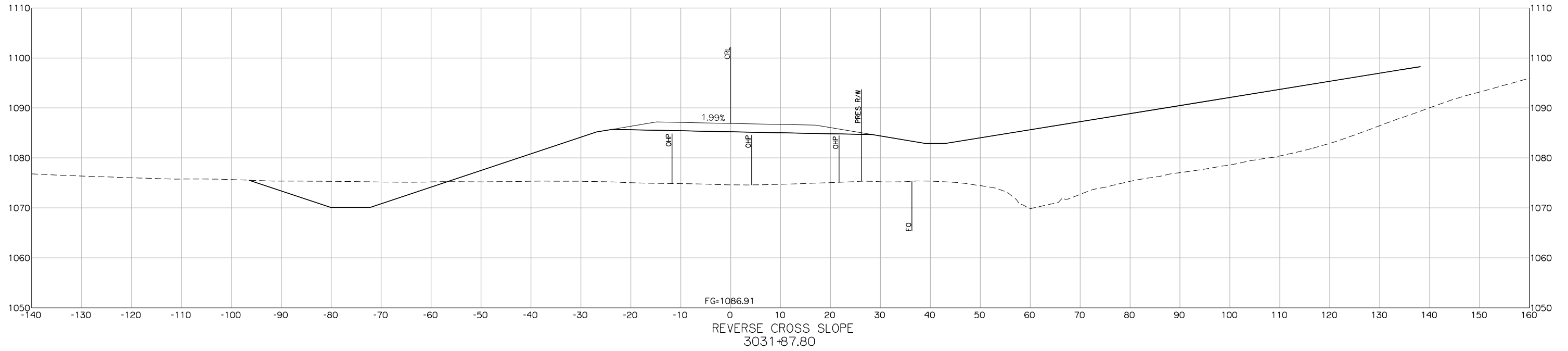

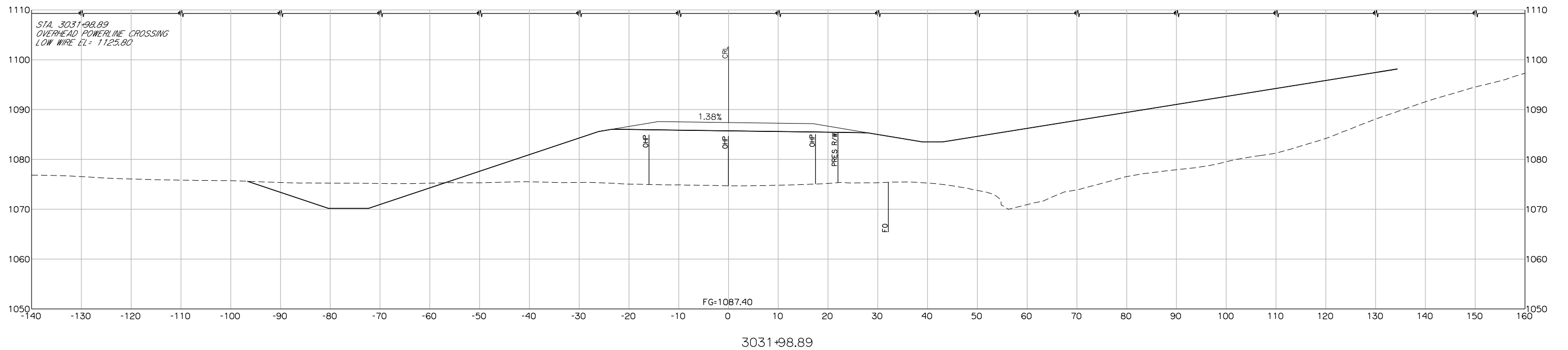
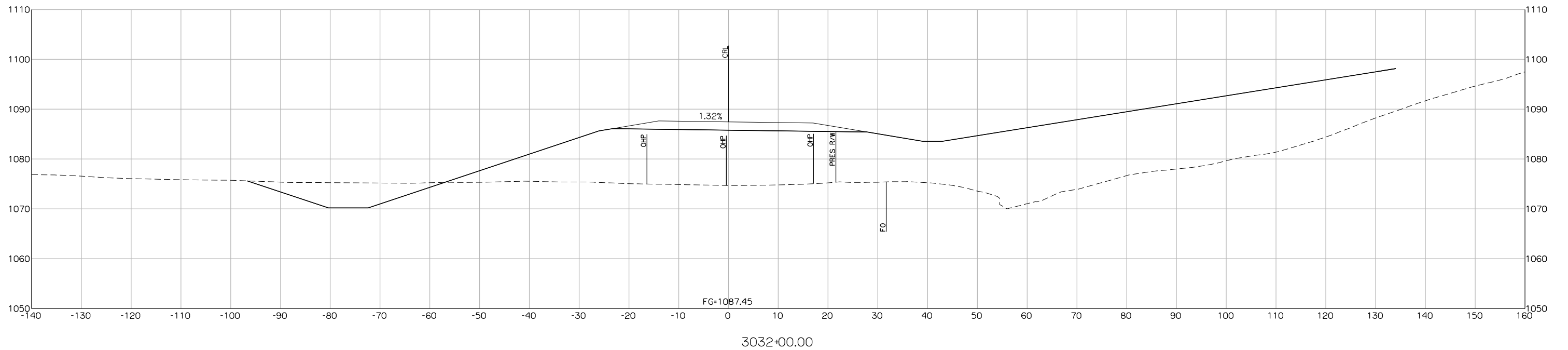

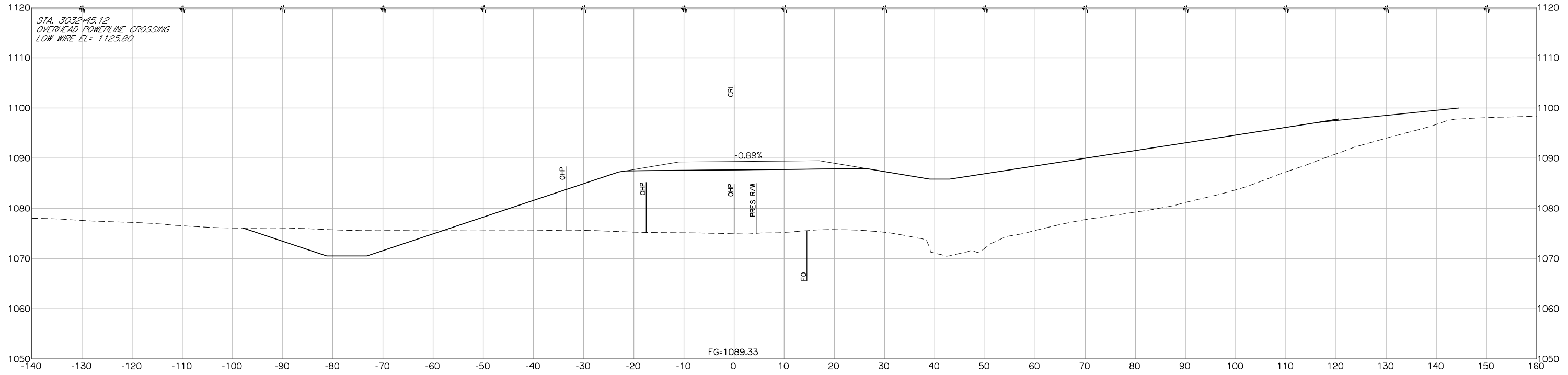

3032+45.12

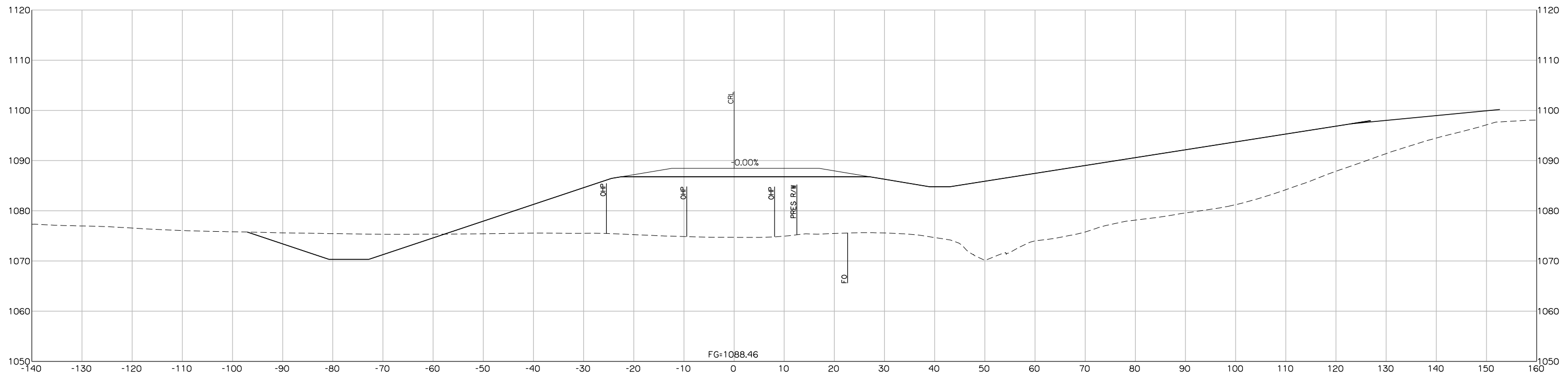

RUNOFF ENDS STATION
3032+23.80

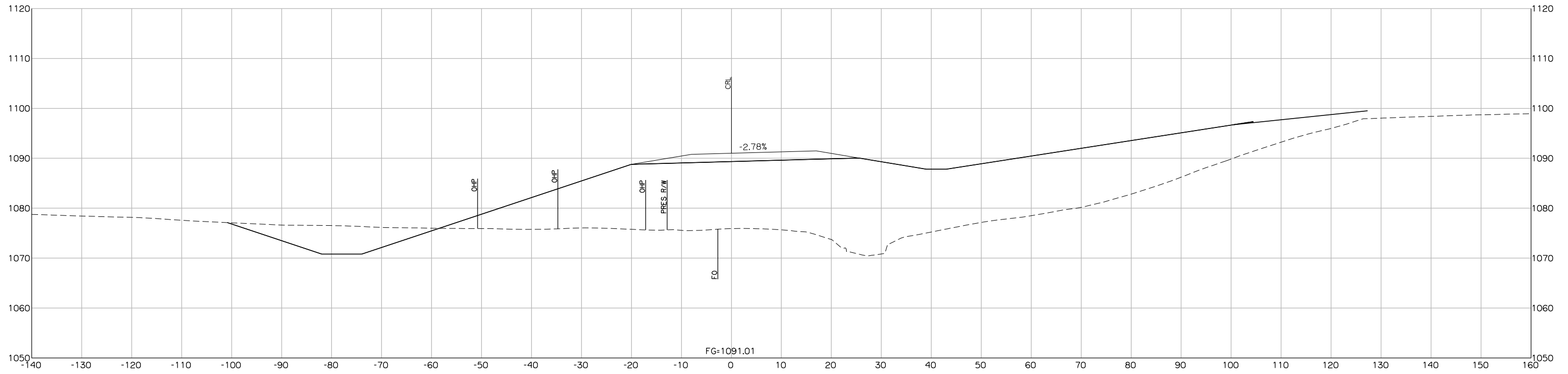

3032+90.46

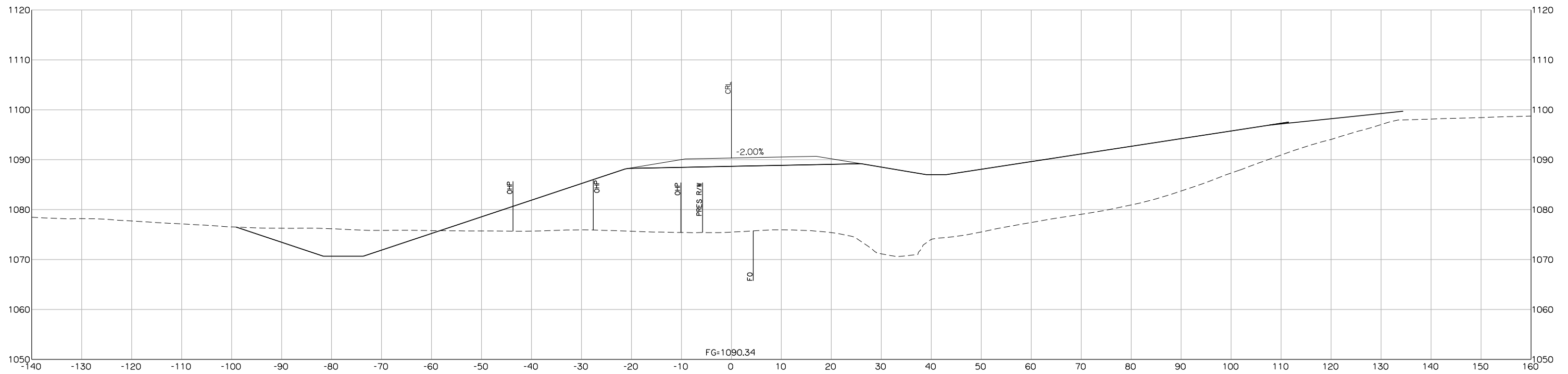

REVERSE CROSS SLOPE
3032+71.80

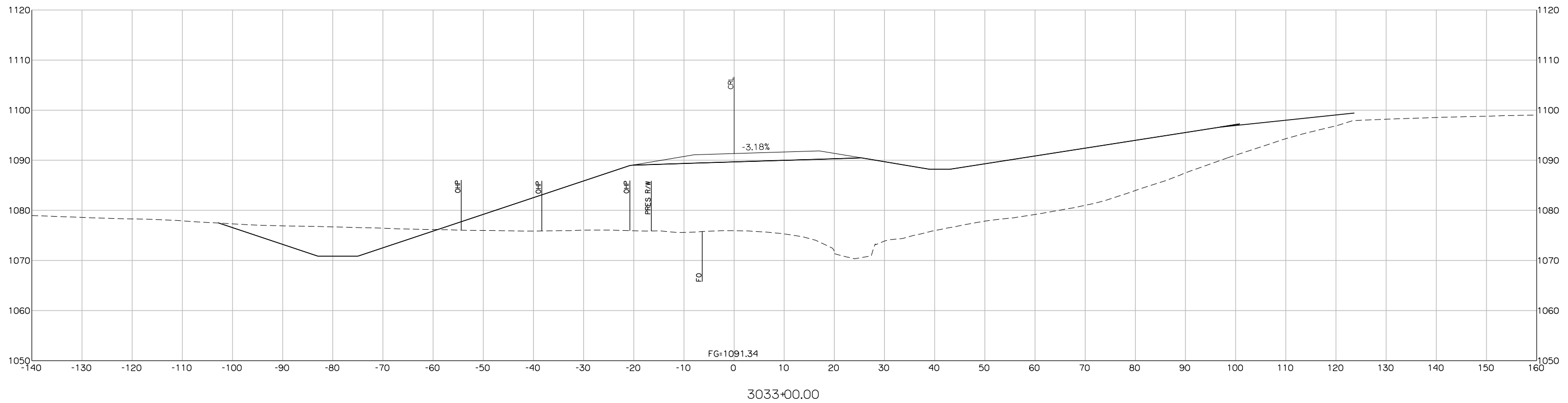
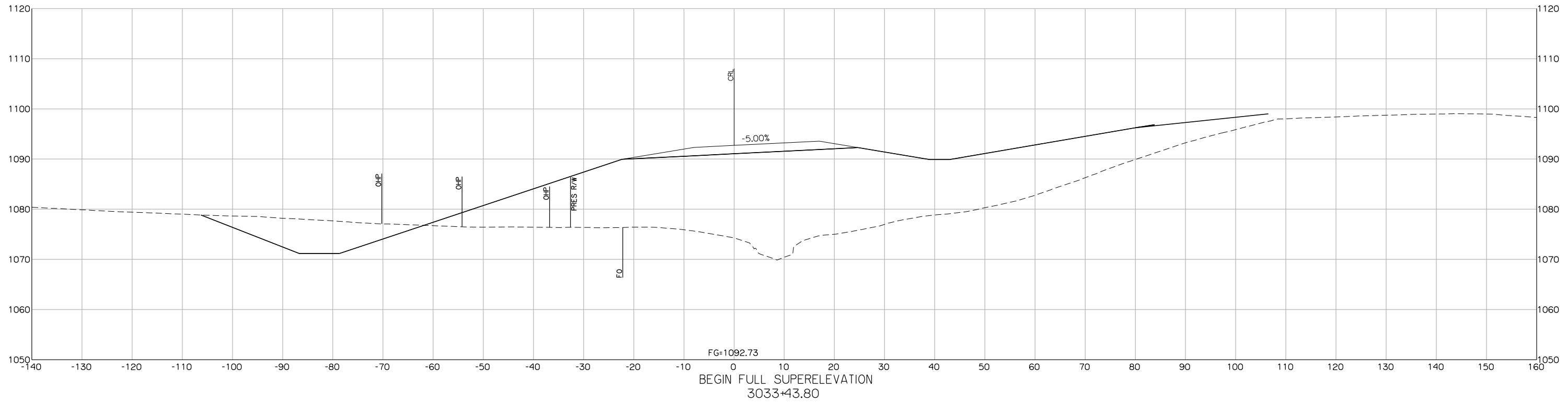

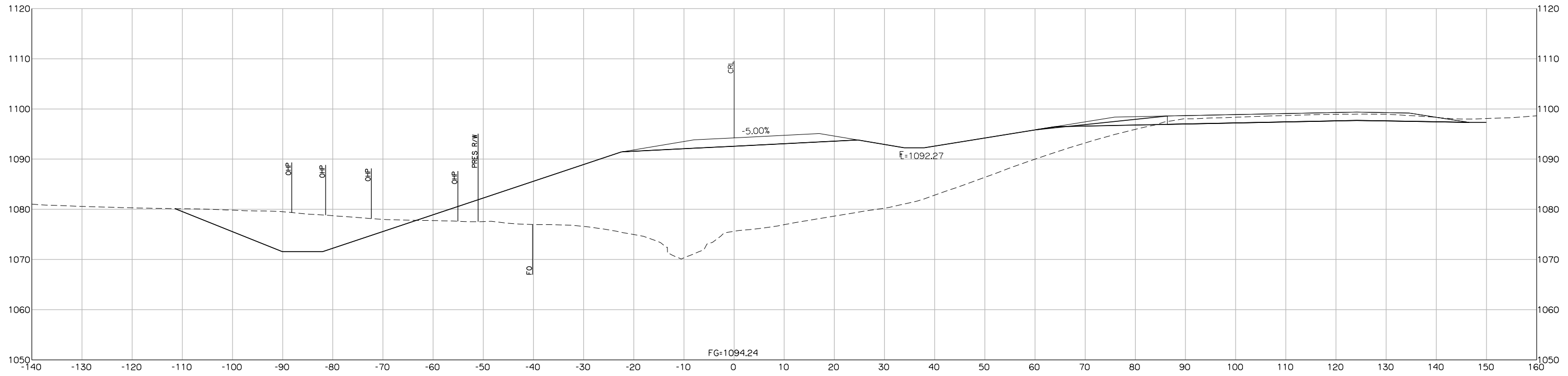

3034+00.00

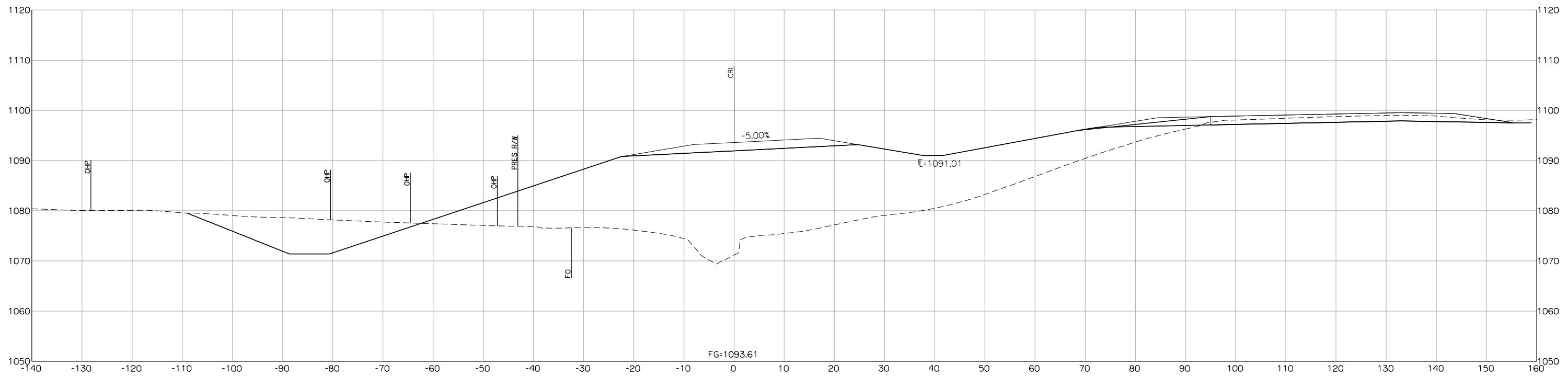

3033+74.91

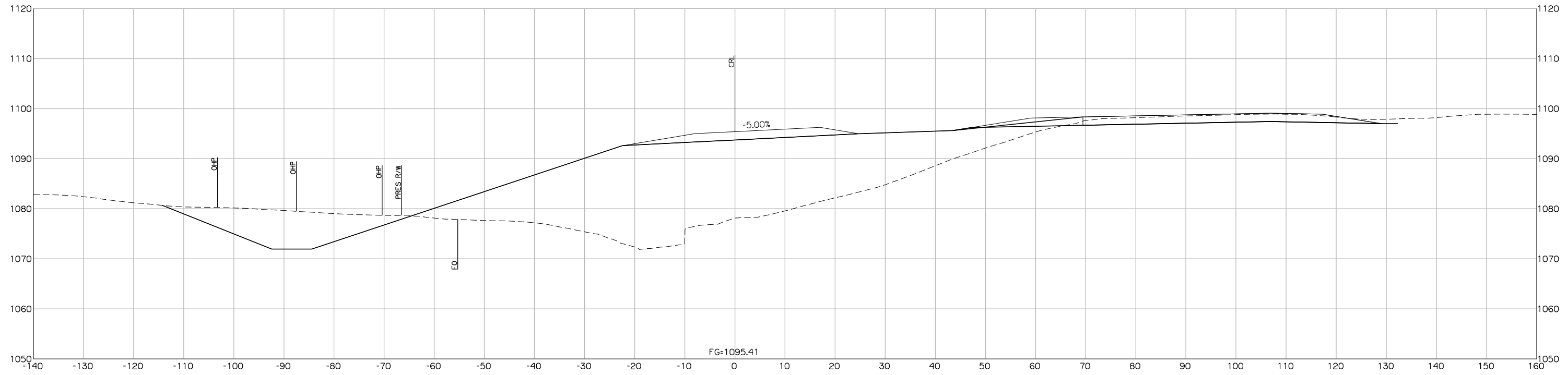

3034+54.26

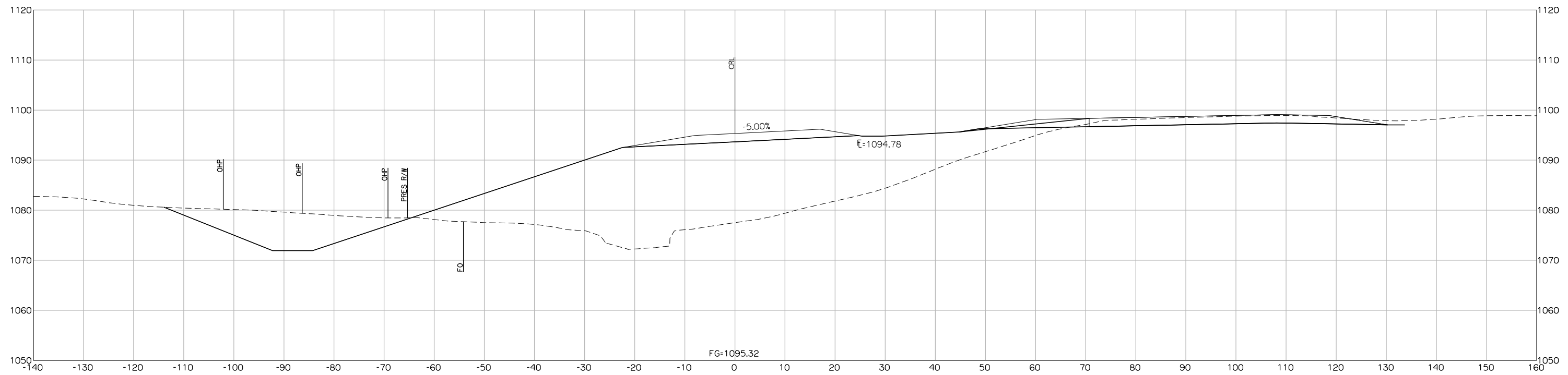

3034+49.91

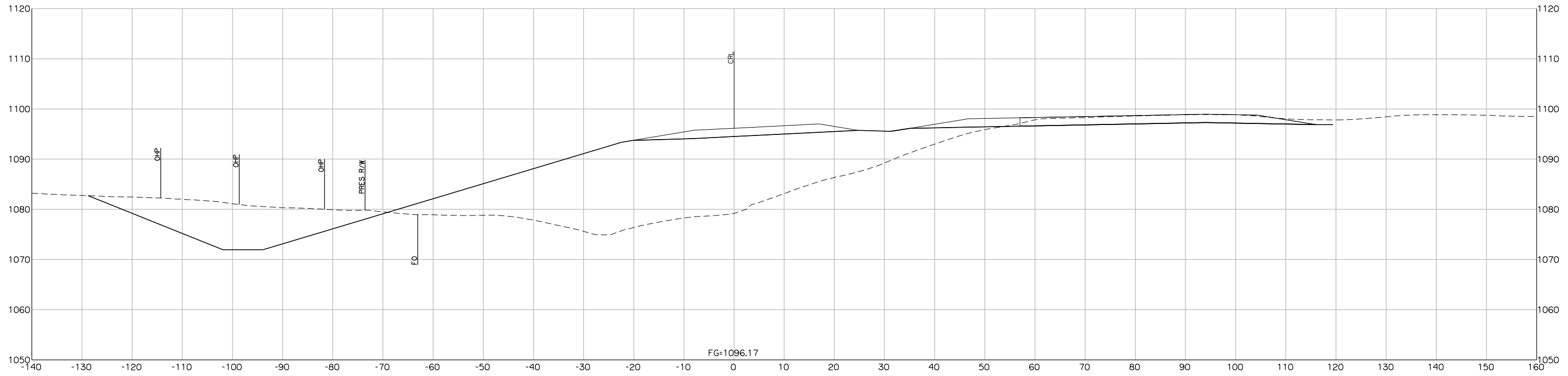

3035+00.00

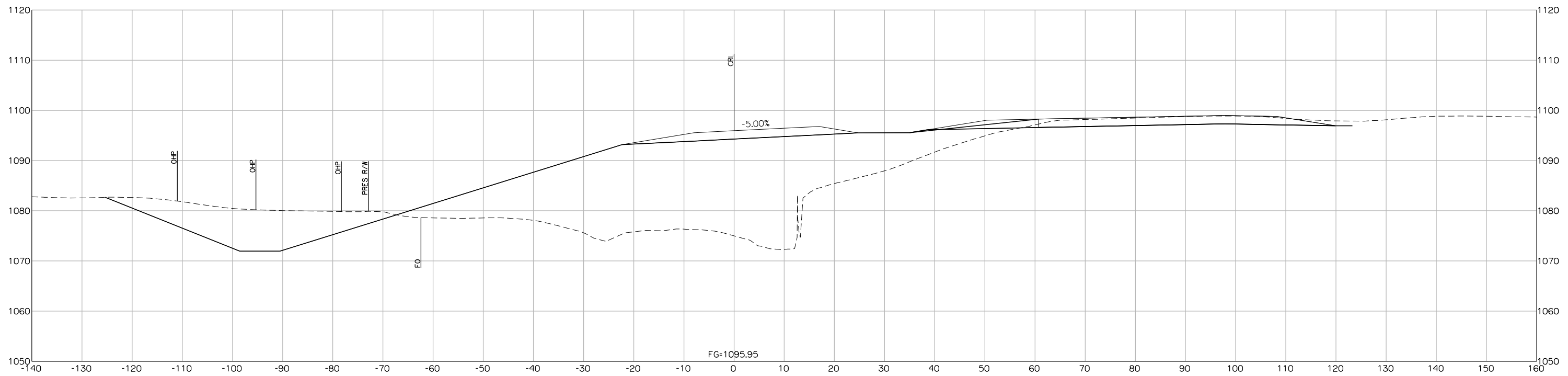

3034+85.71

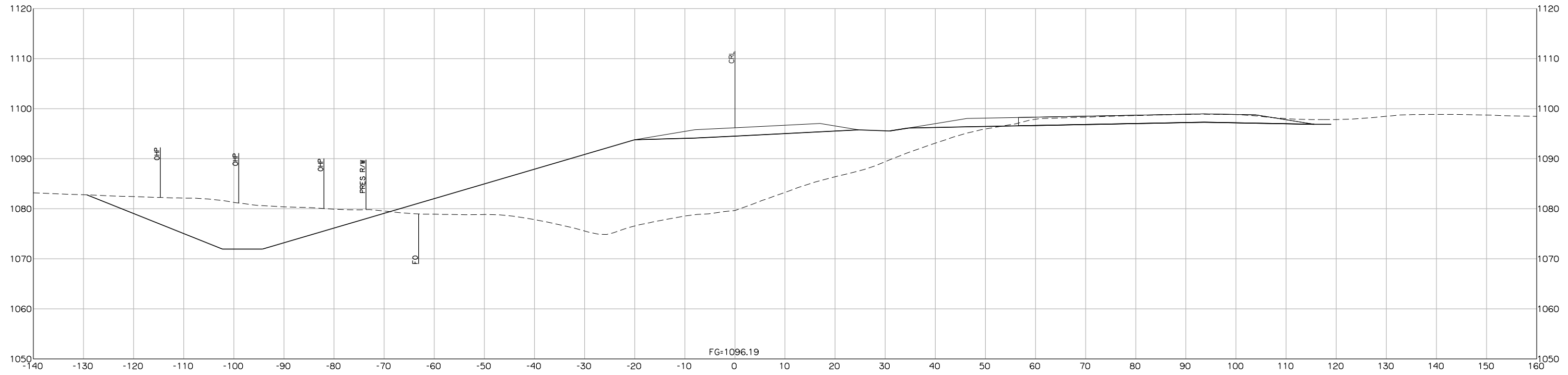

3035+01.58

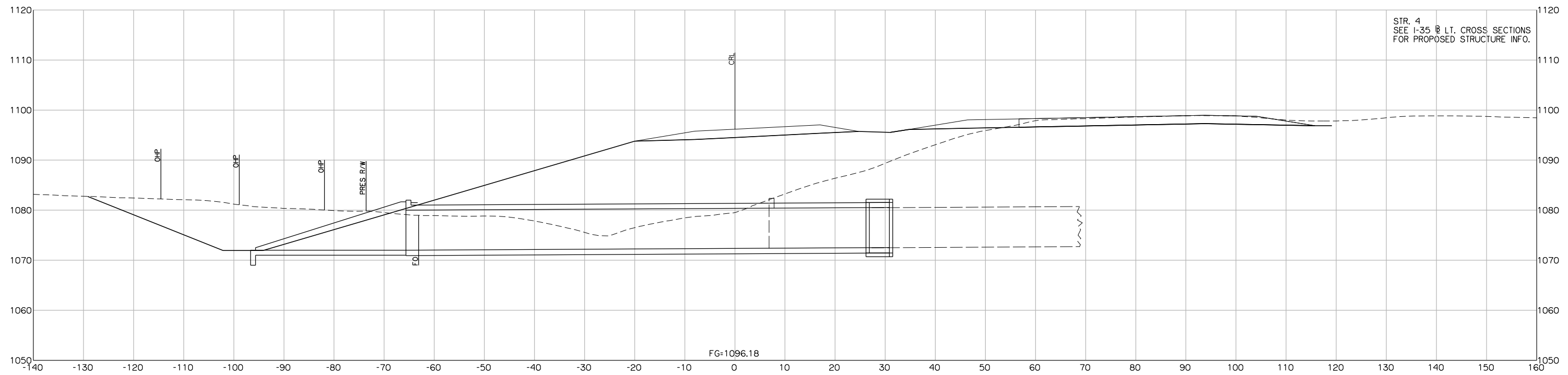

3035+01.14

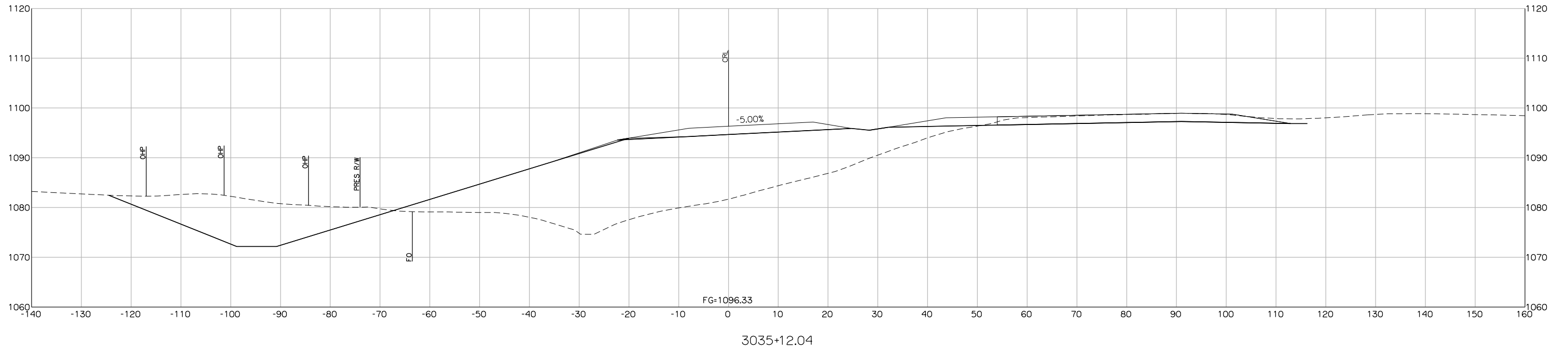

3035+12.04

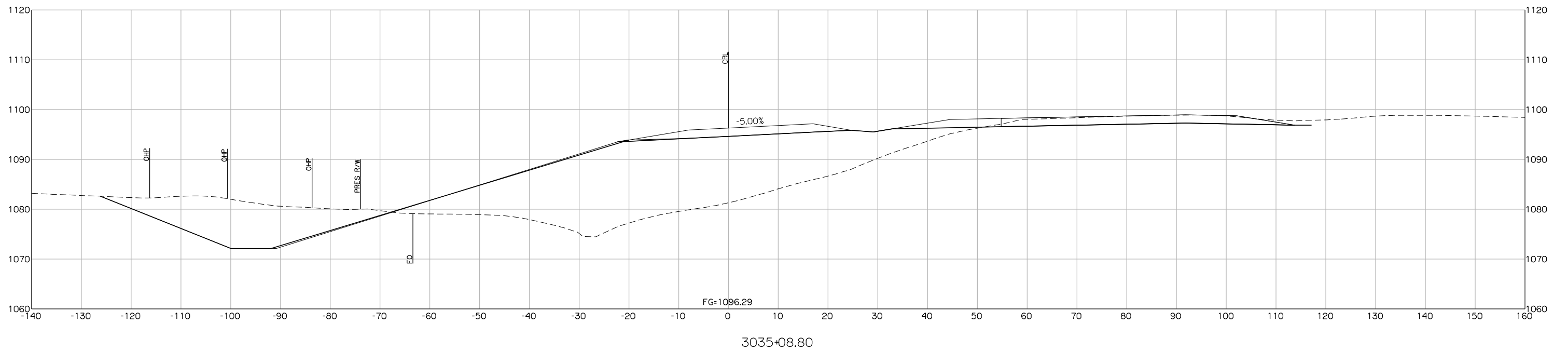

3035+08.80

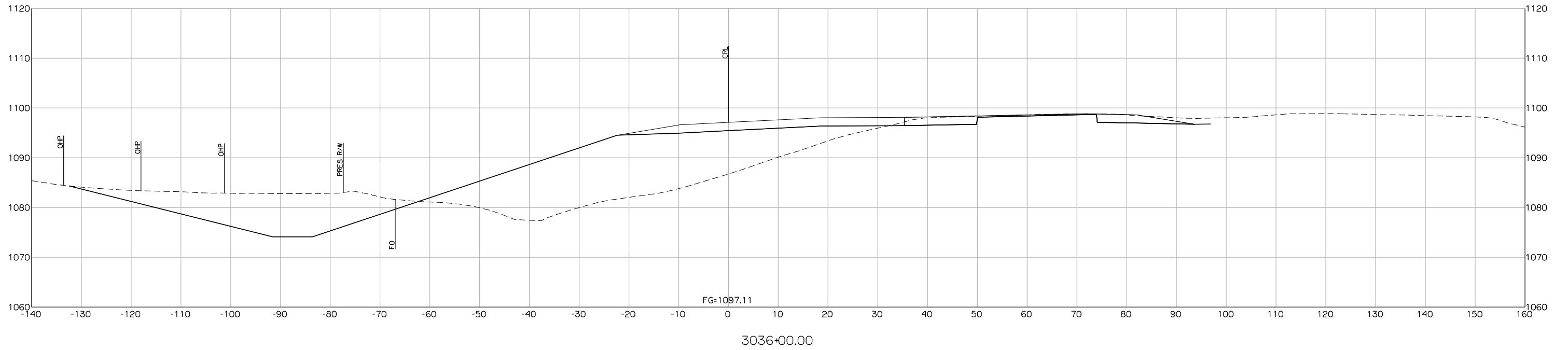

3036+00.00

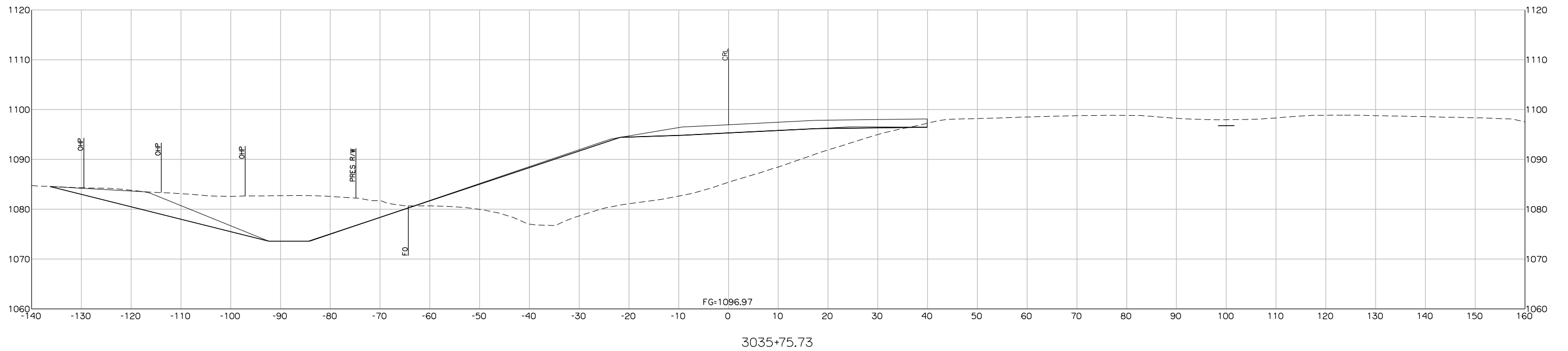

3035+75.73

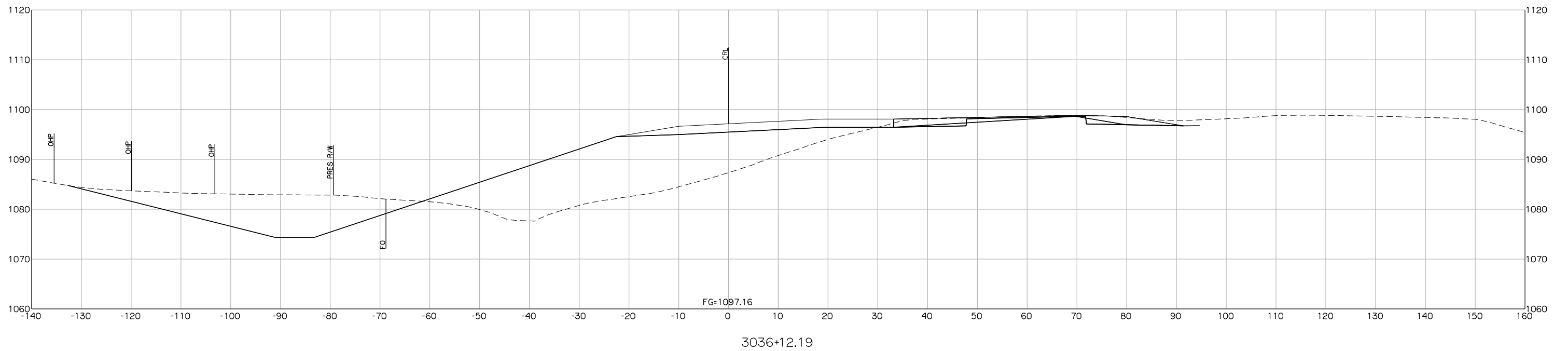
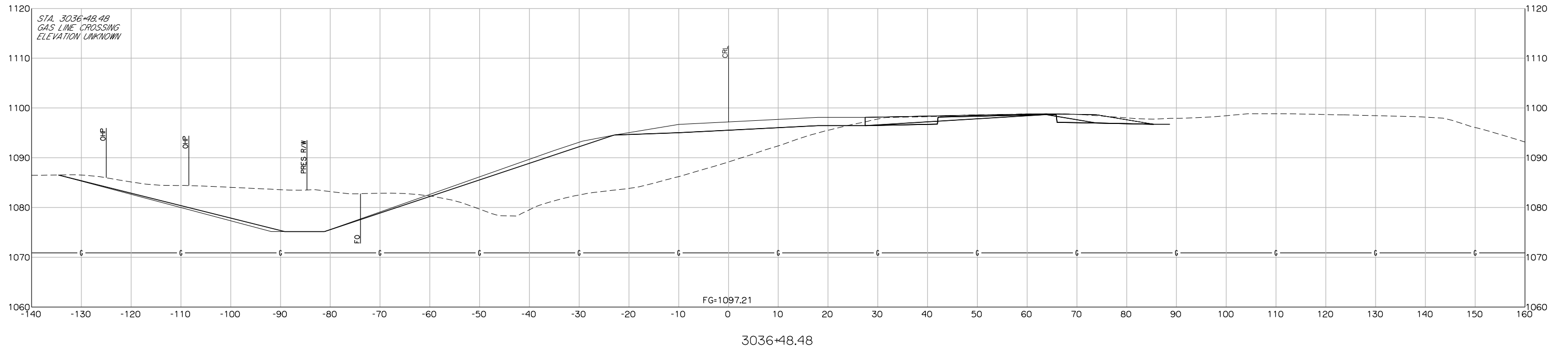

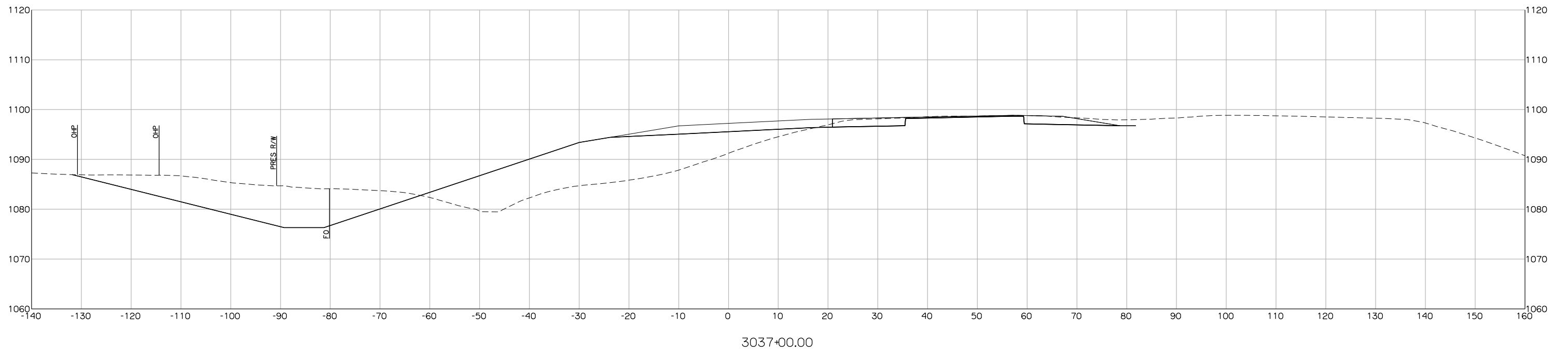
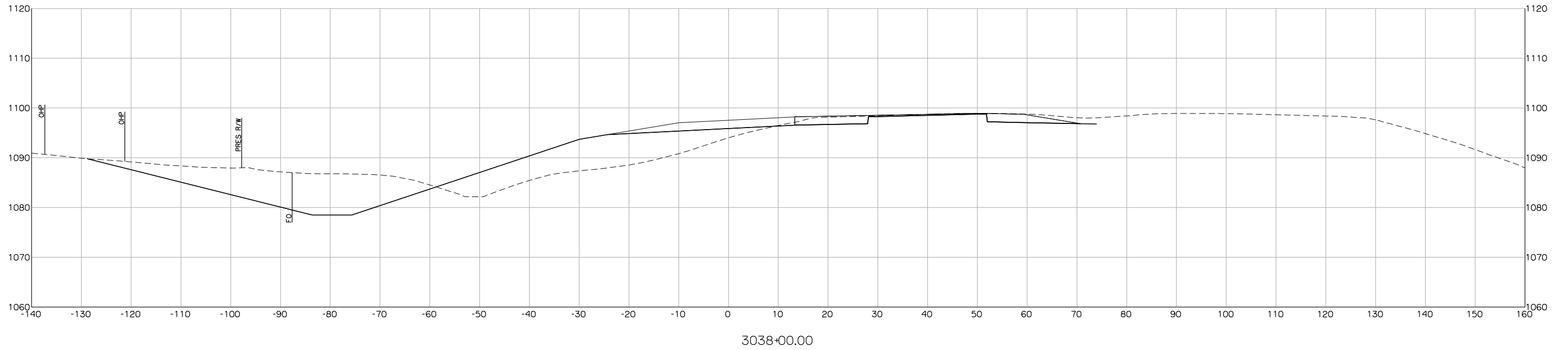

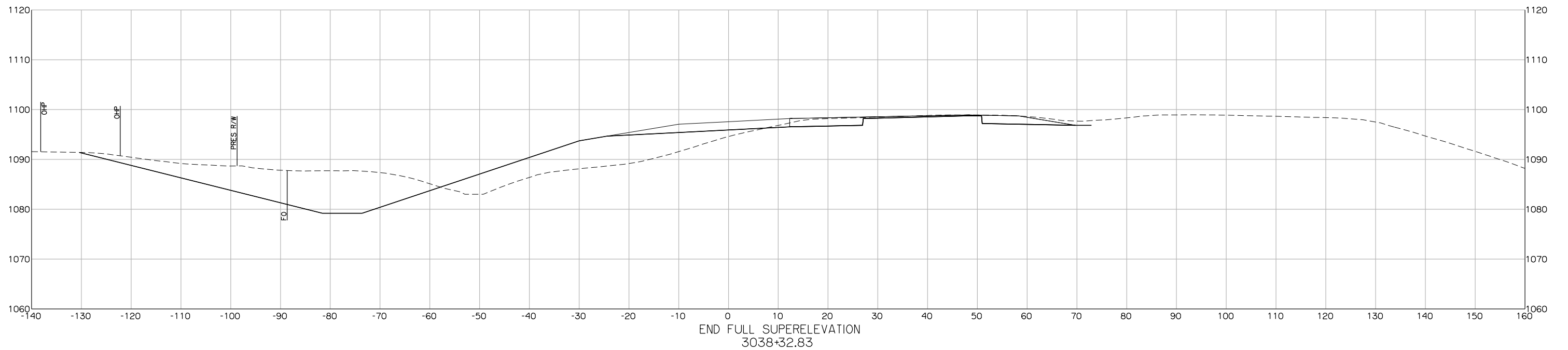
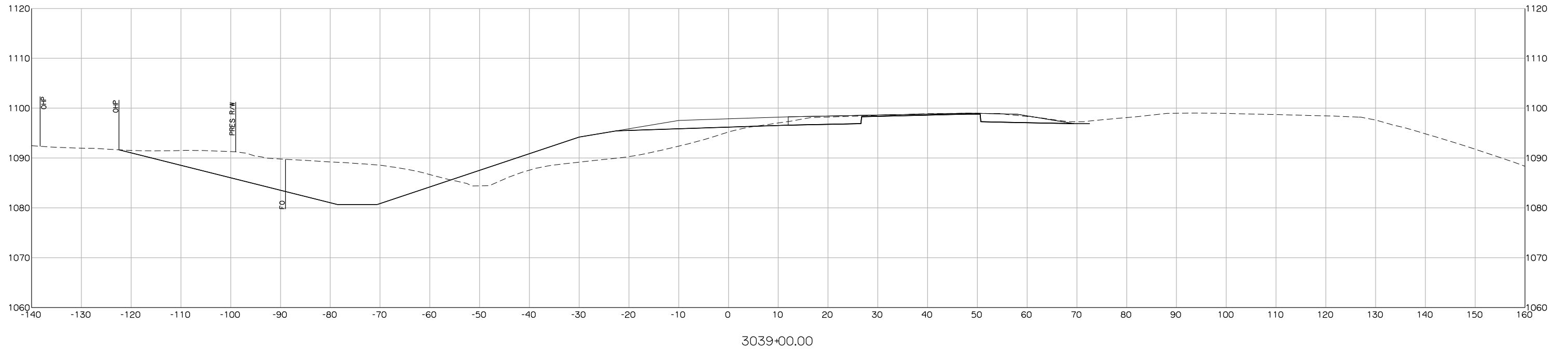

END FULL SUPERELEVATION
3038+32.83

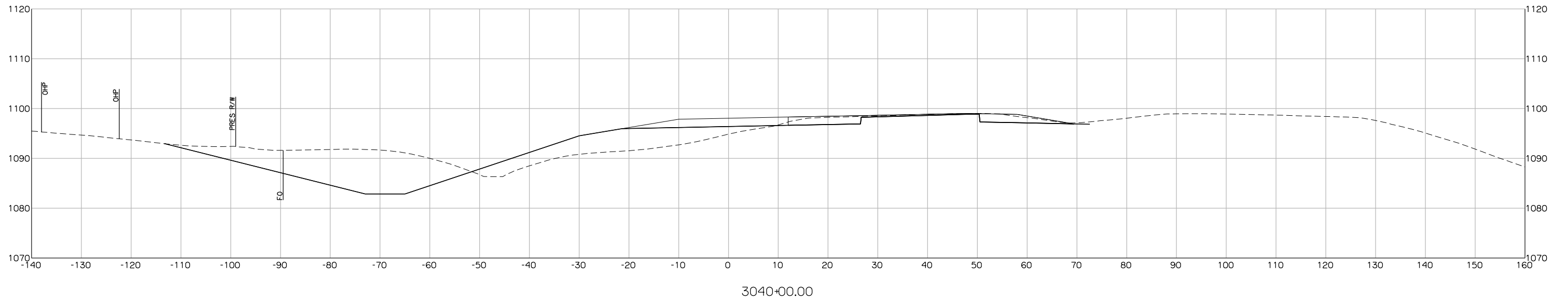

3040+00.00

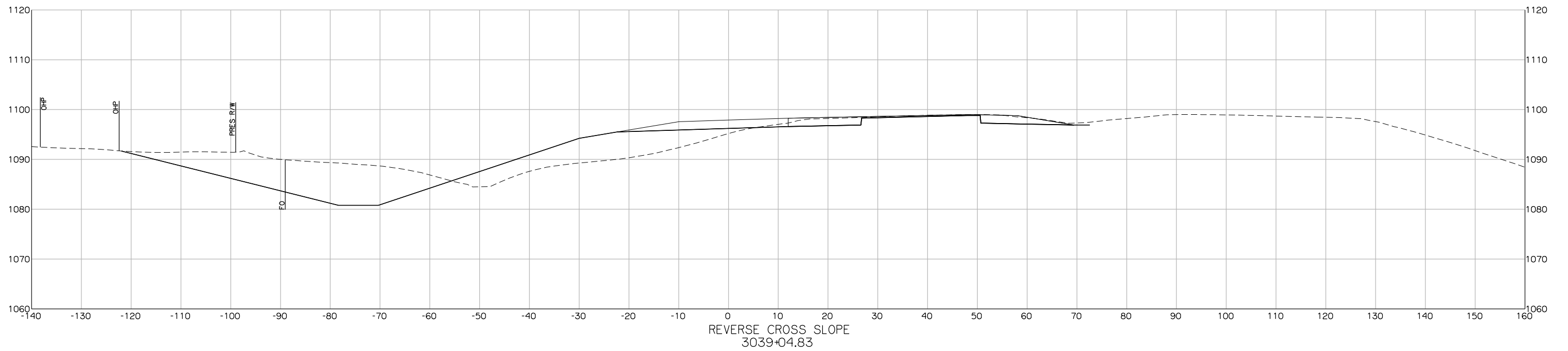

REVERSE CROSS SLOPE
3039+04.83

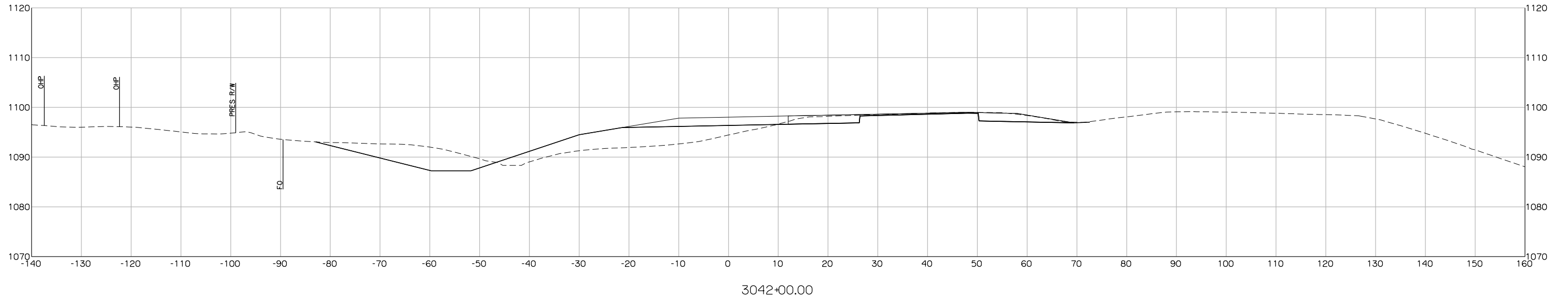

3042+00.00

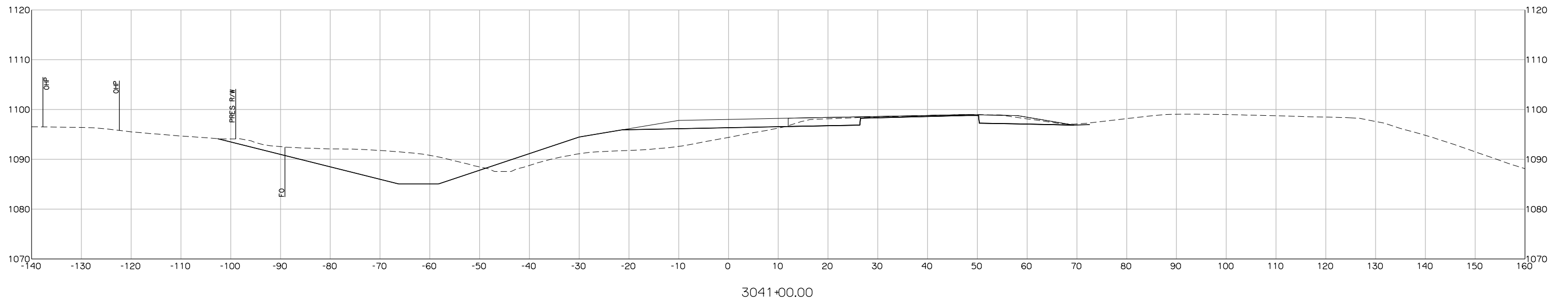

3041+00.00

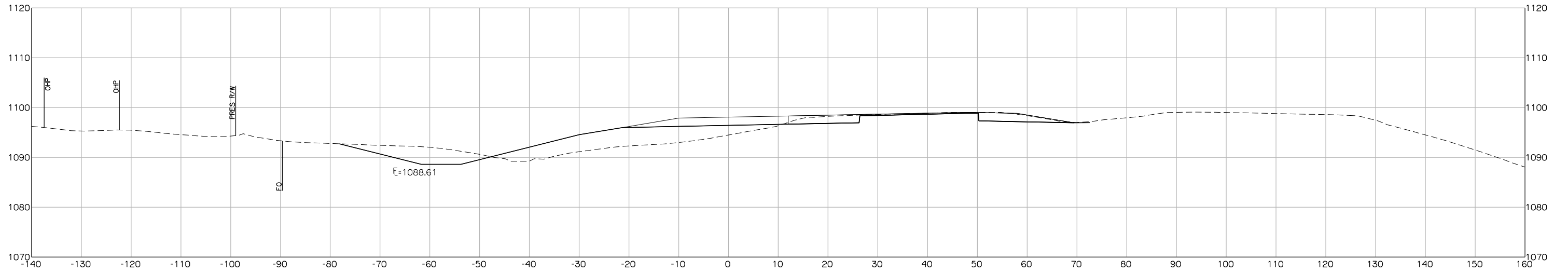

3042+99.91

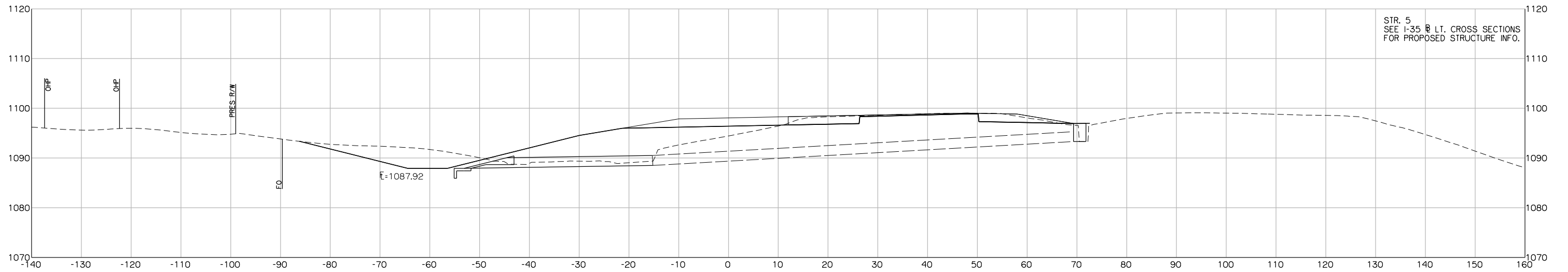

3042+49.06

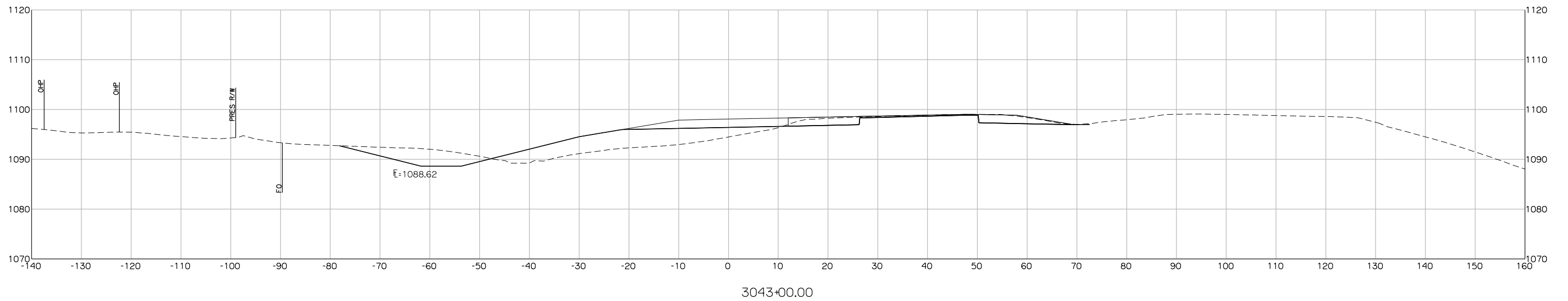
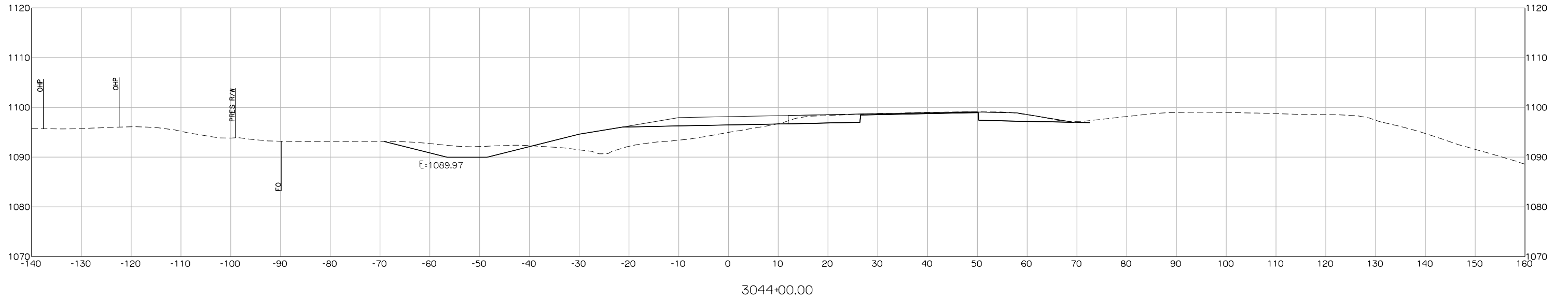

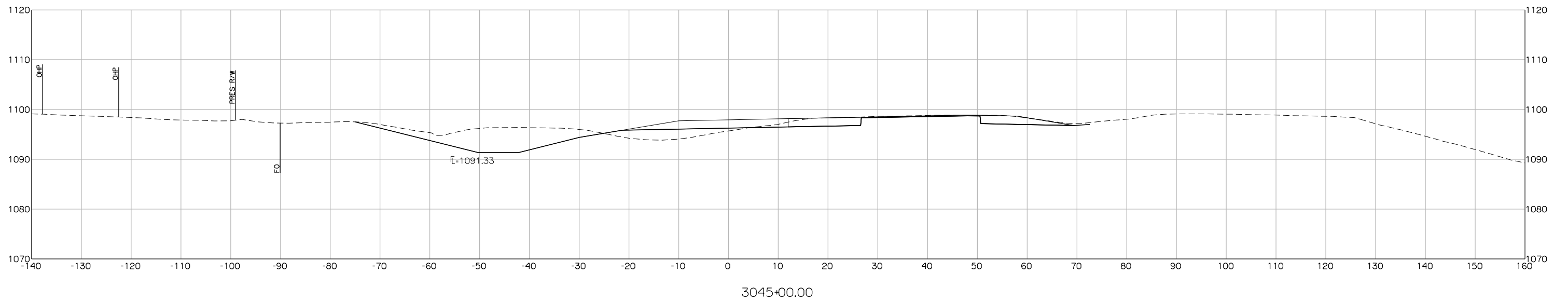
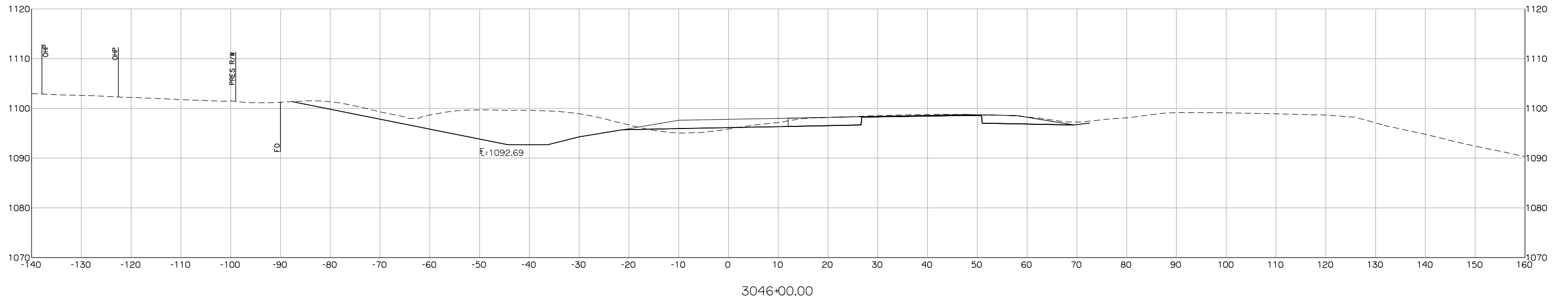

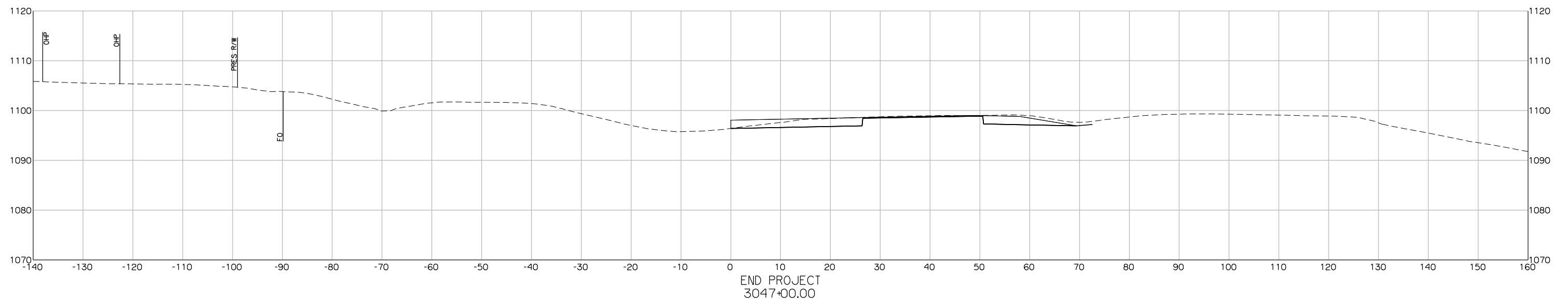
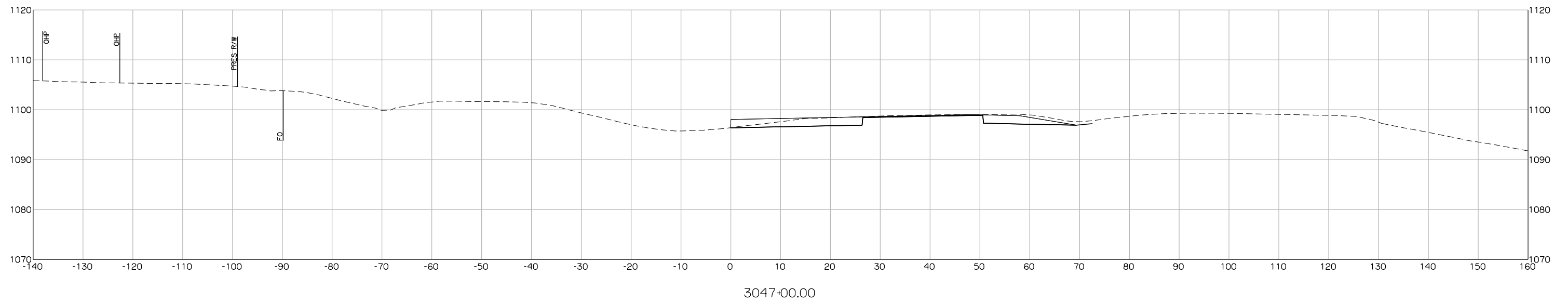

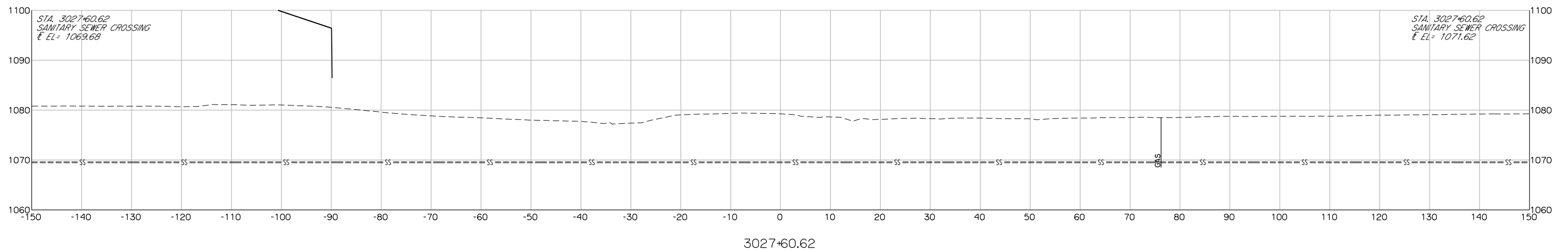
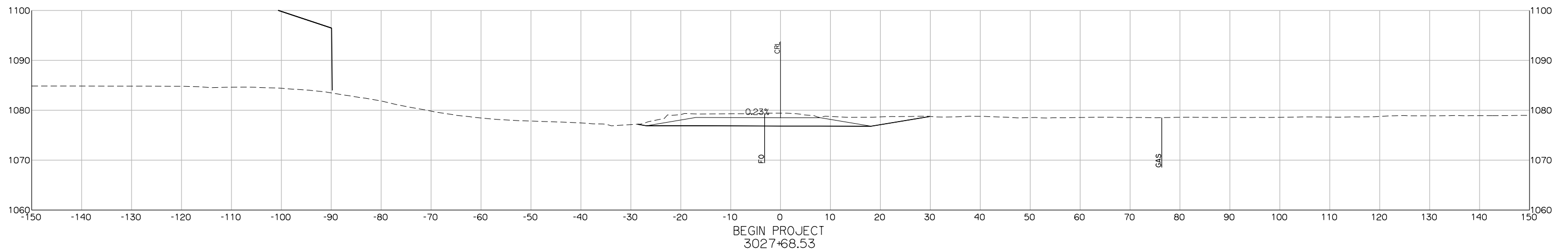
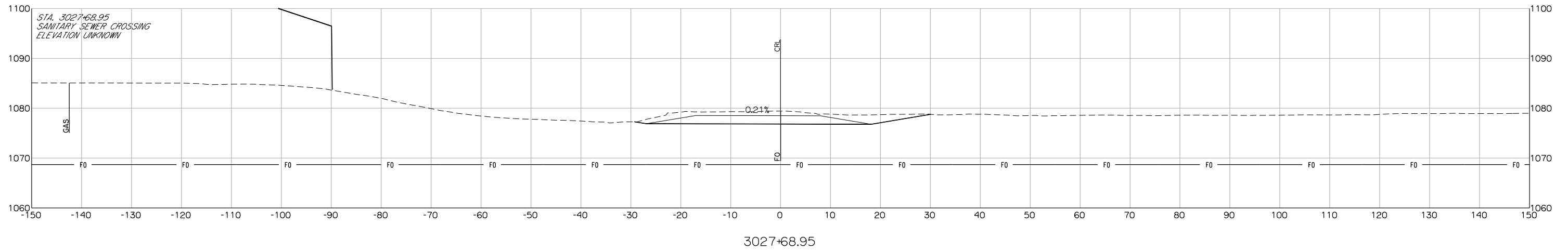

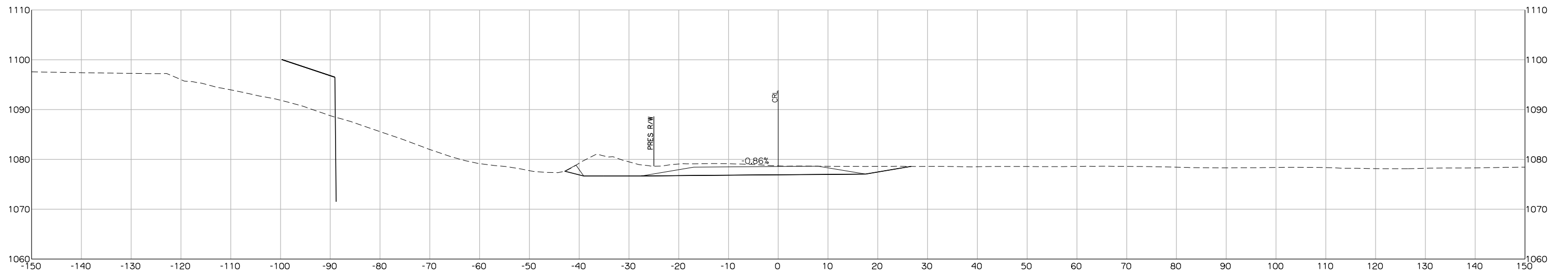

3027+93.00

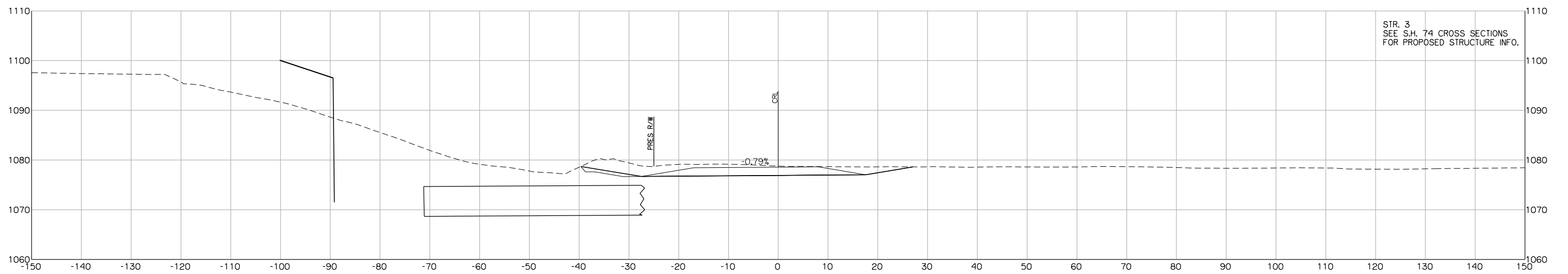

3027+91.47

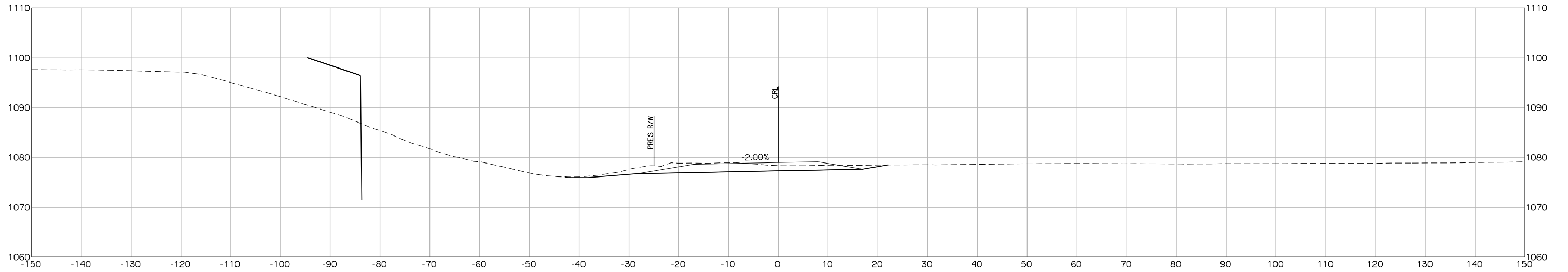

3028+29.95

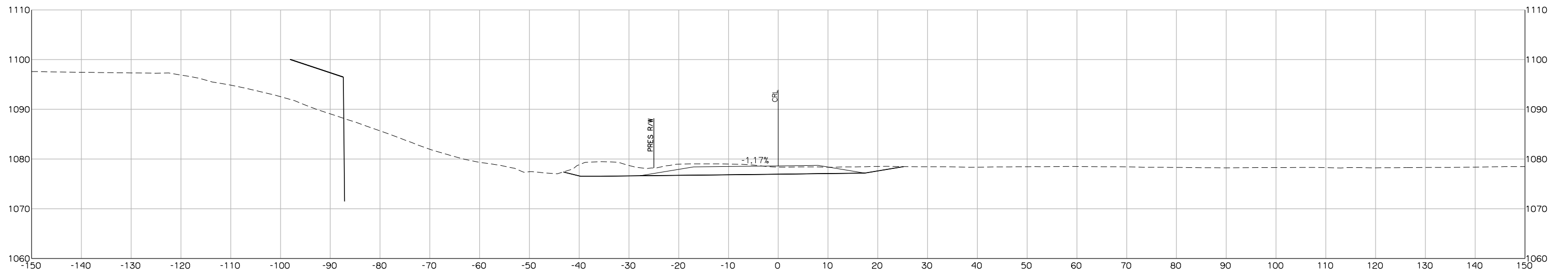

3028+00.00

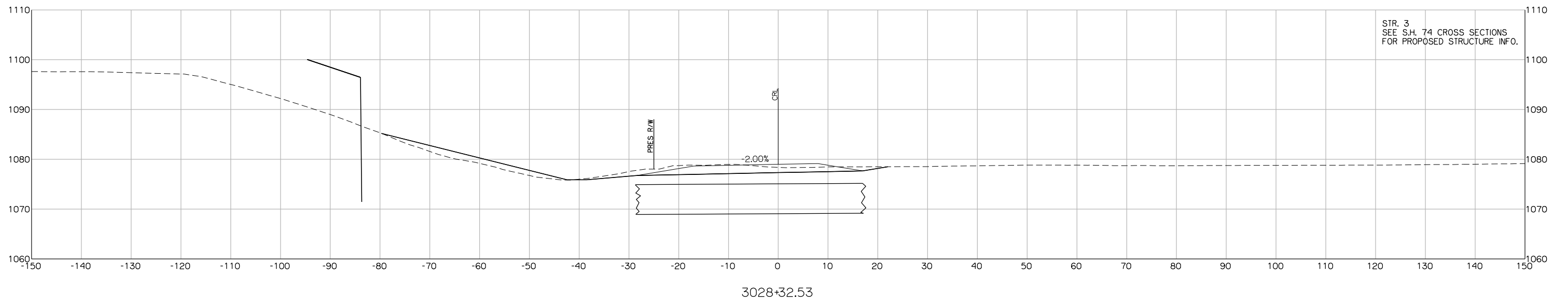
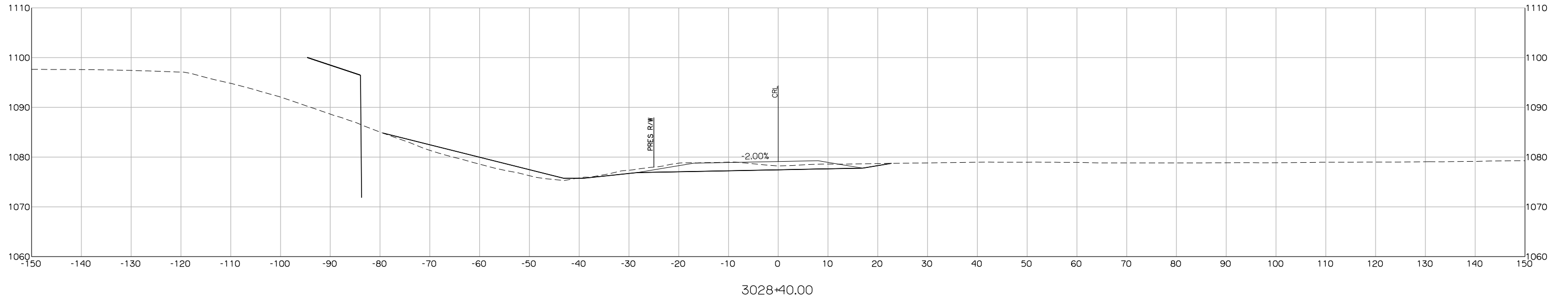

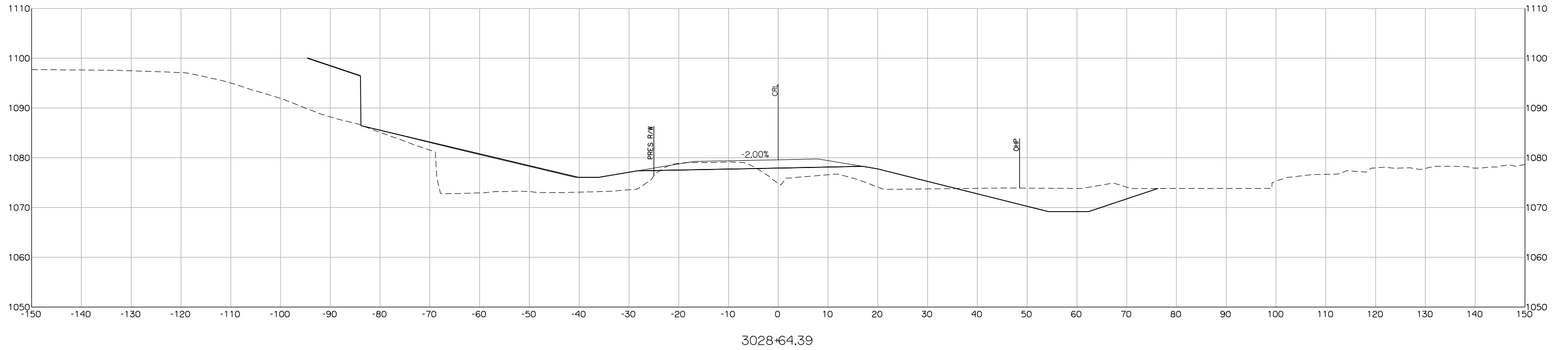

3028+64.39

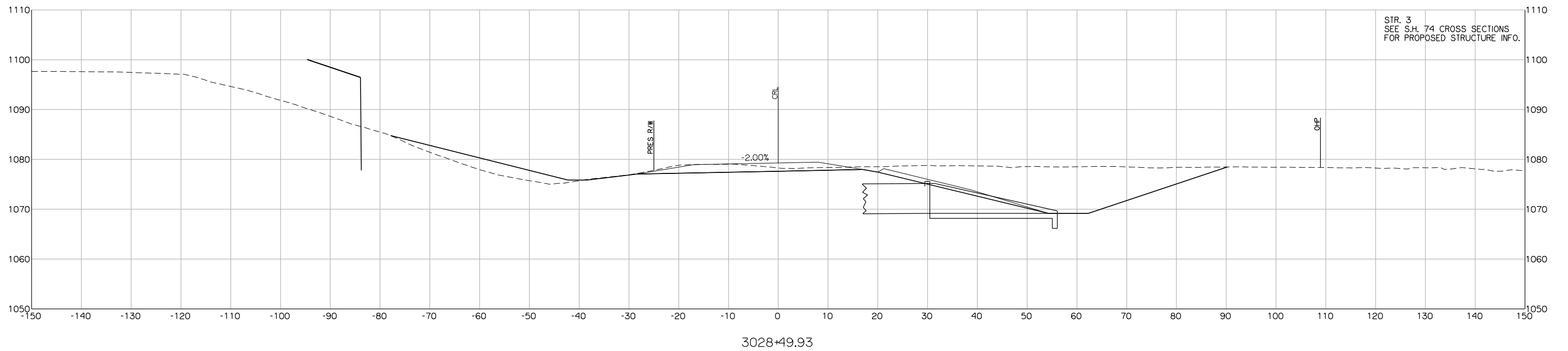

3028+49.93

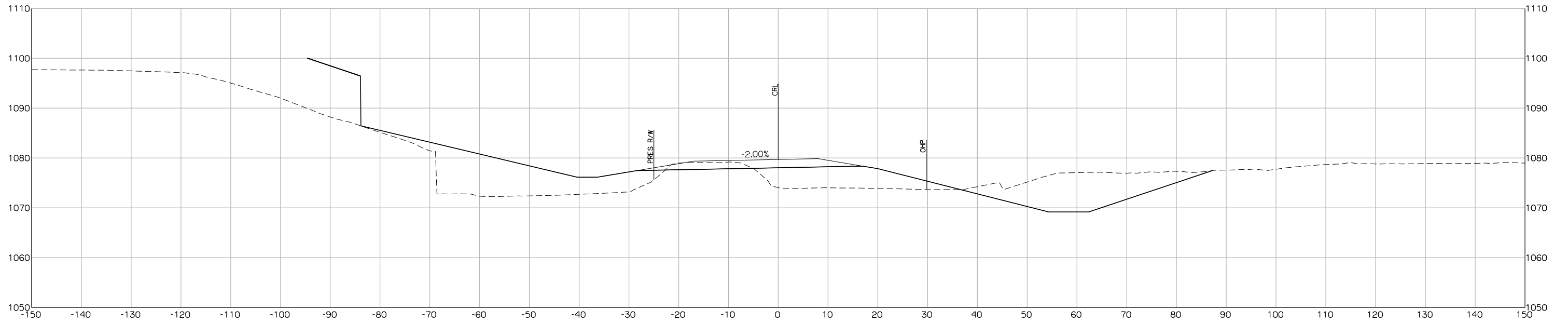

3028+68.88

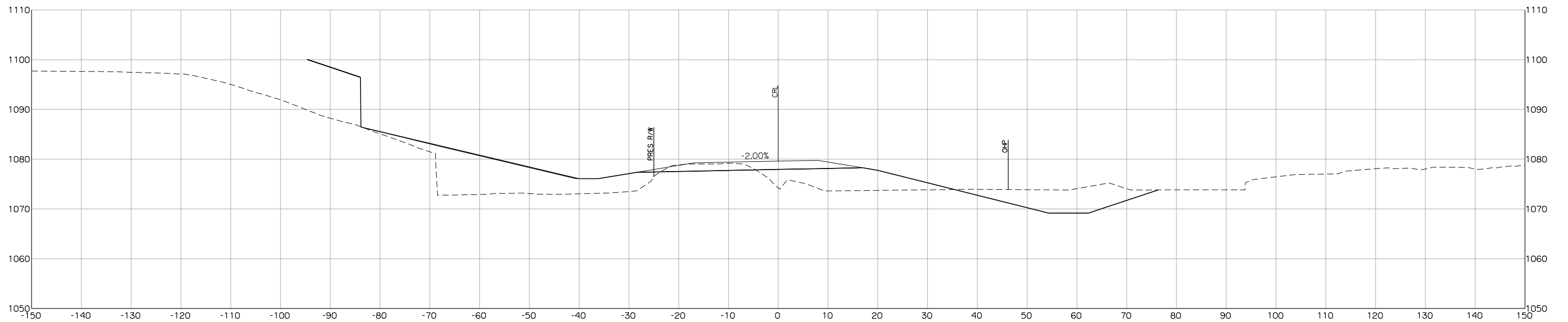

3028+64.94

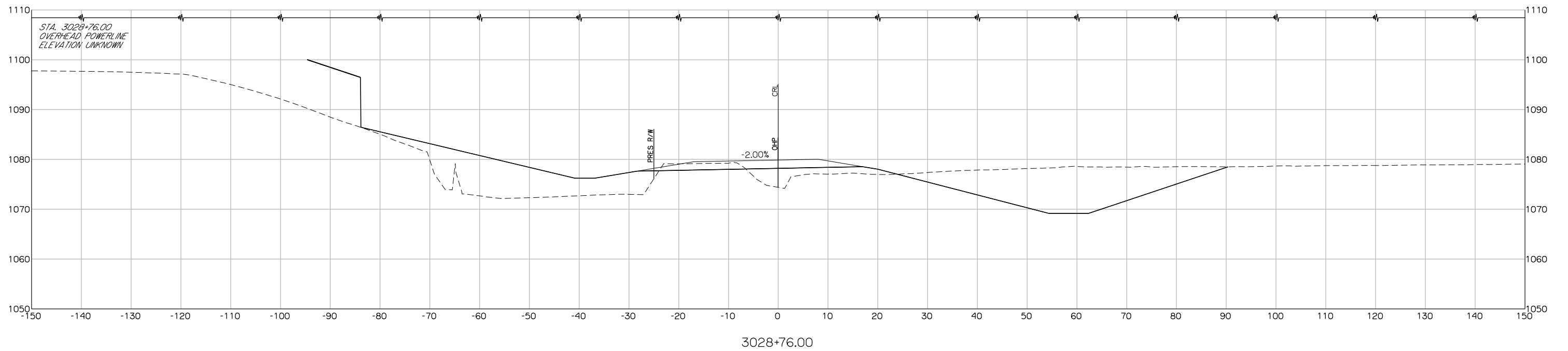
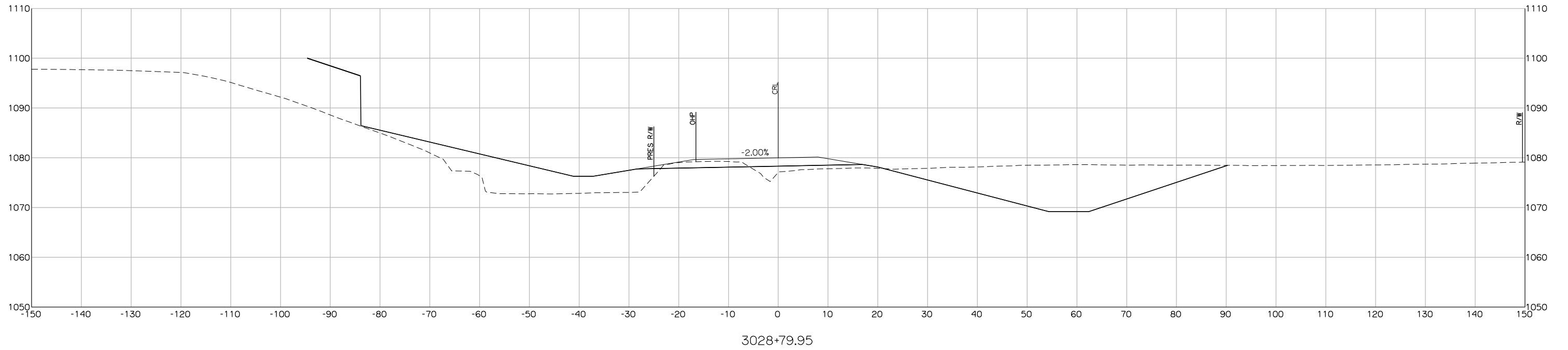

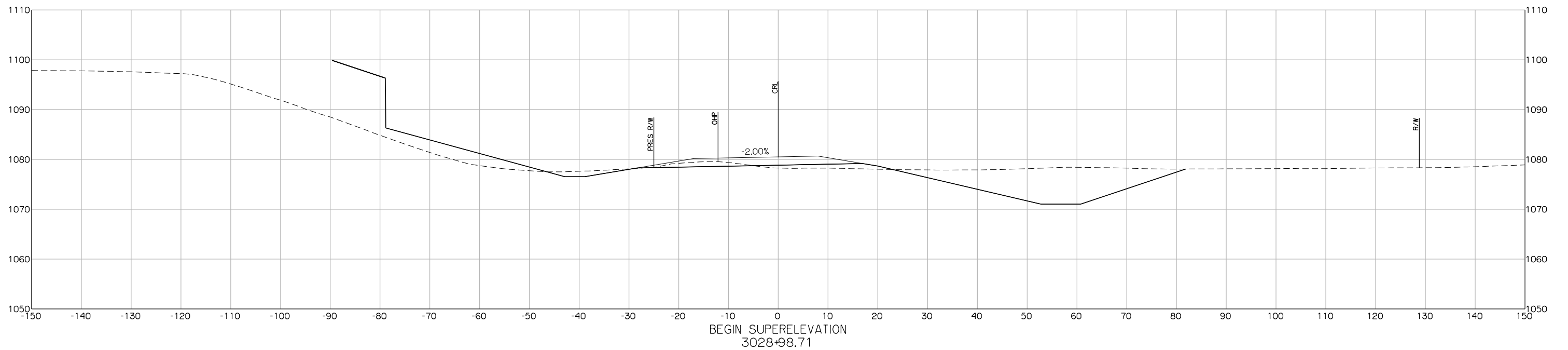
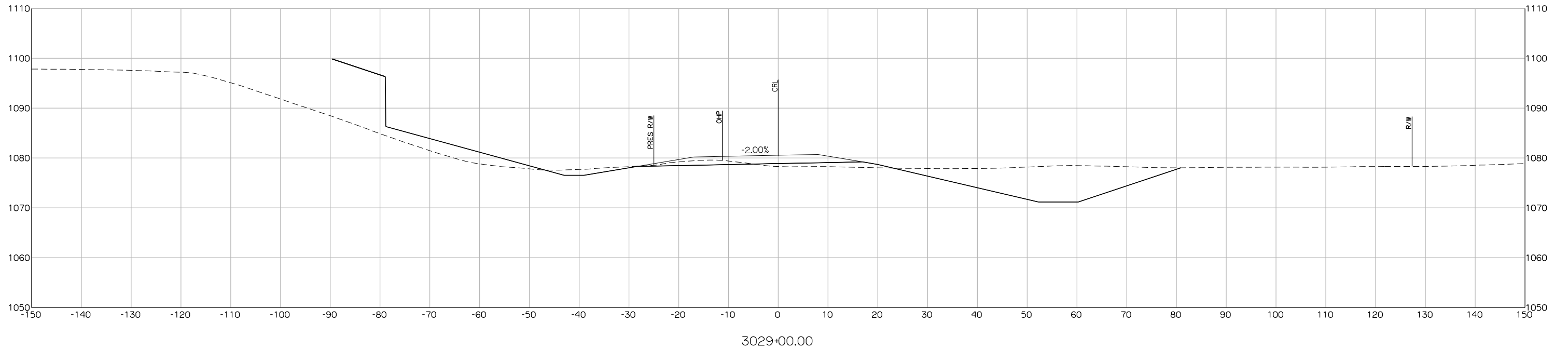

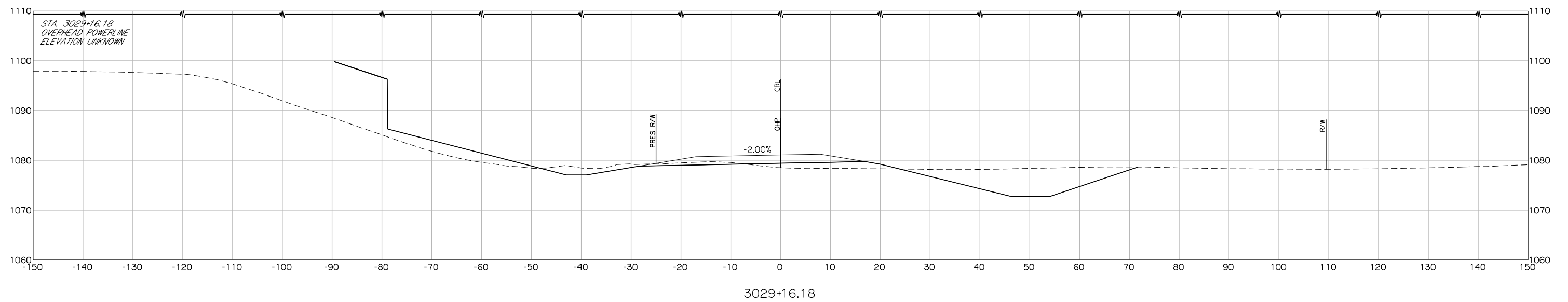
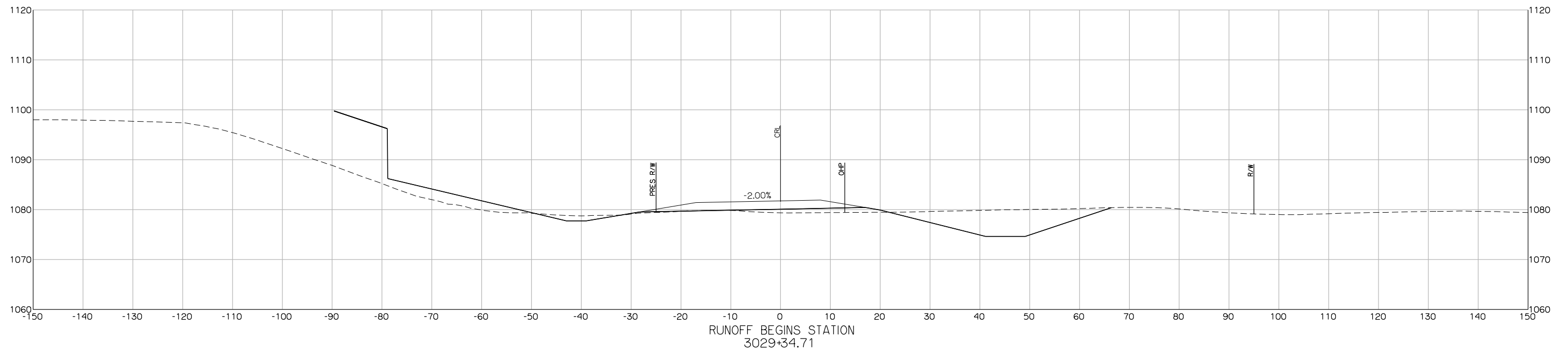

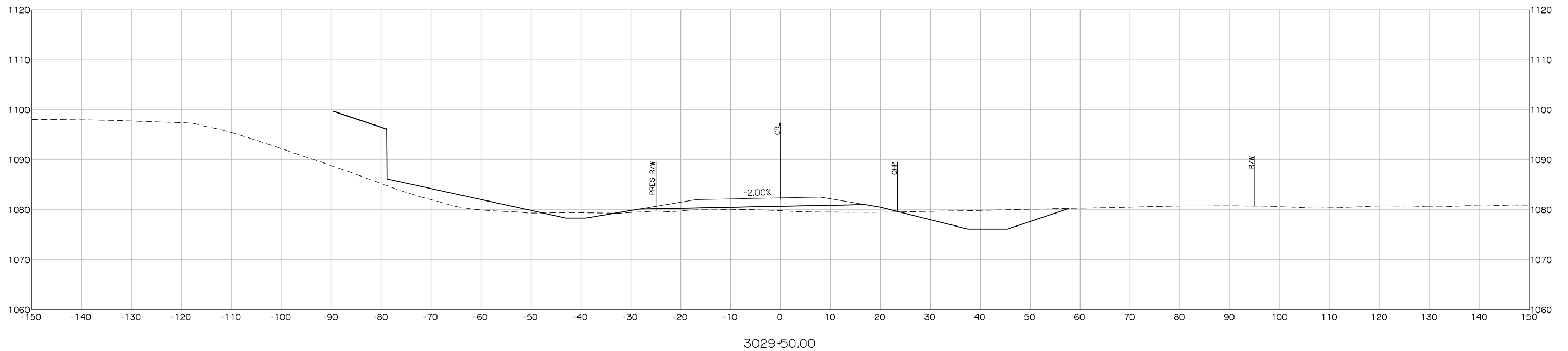
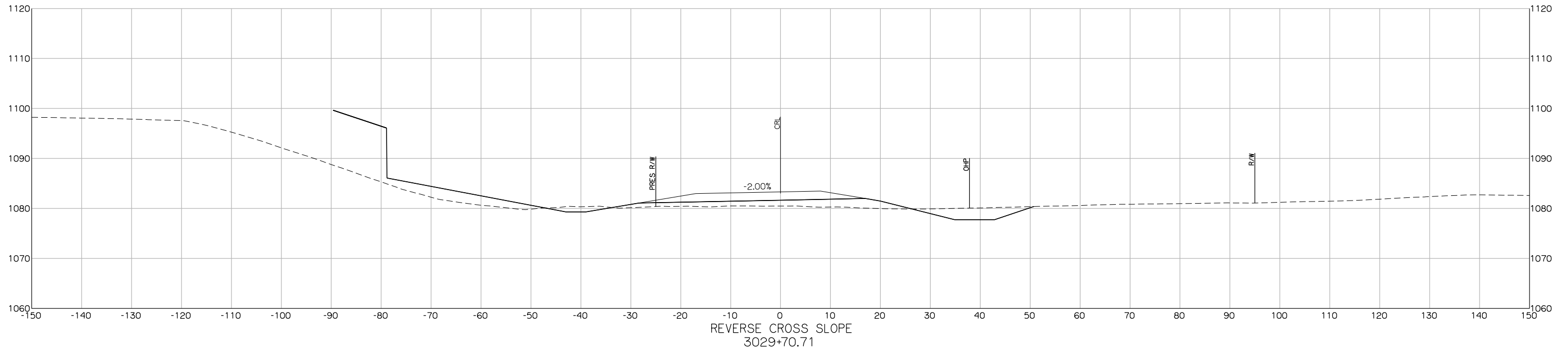

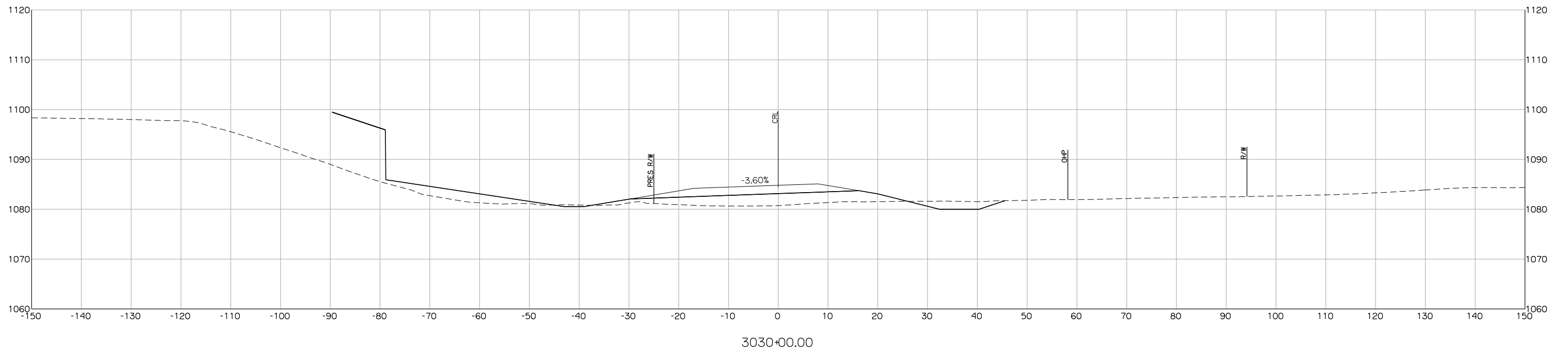
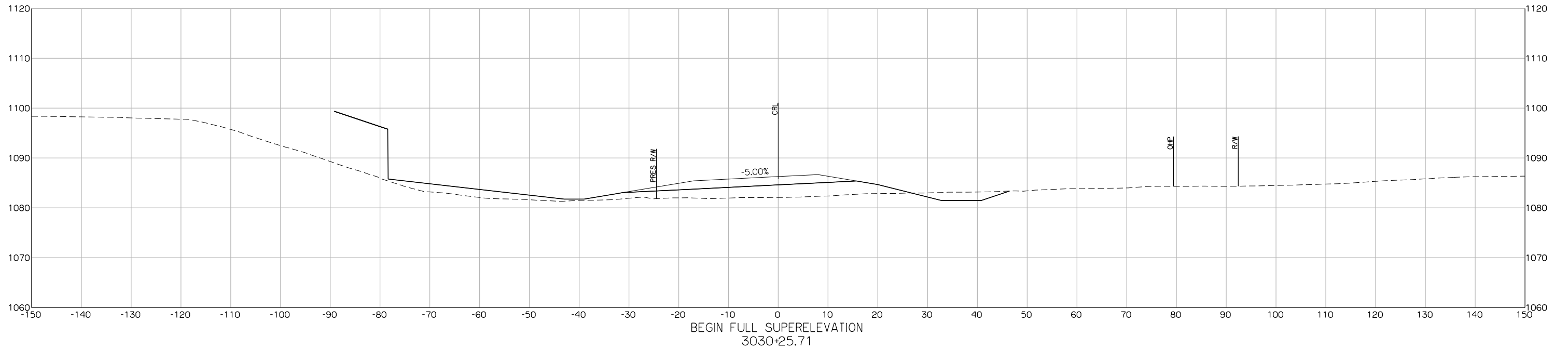

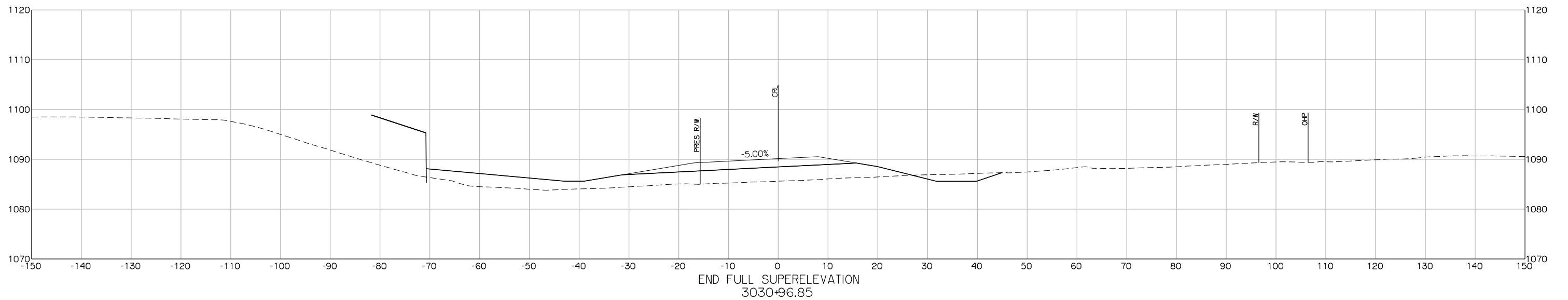
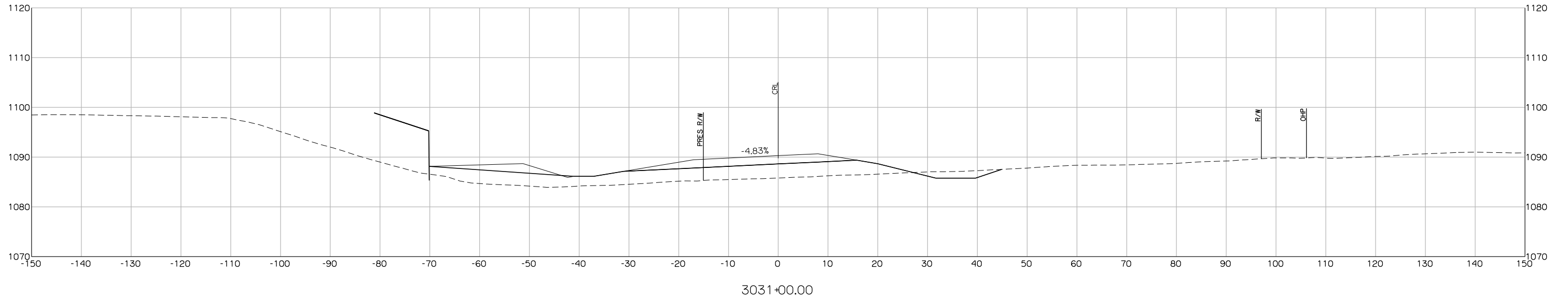

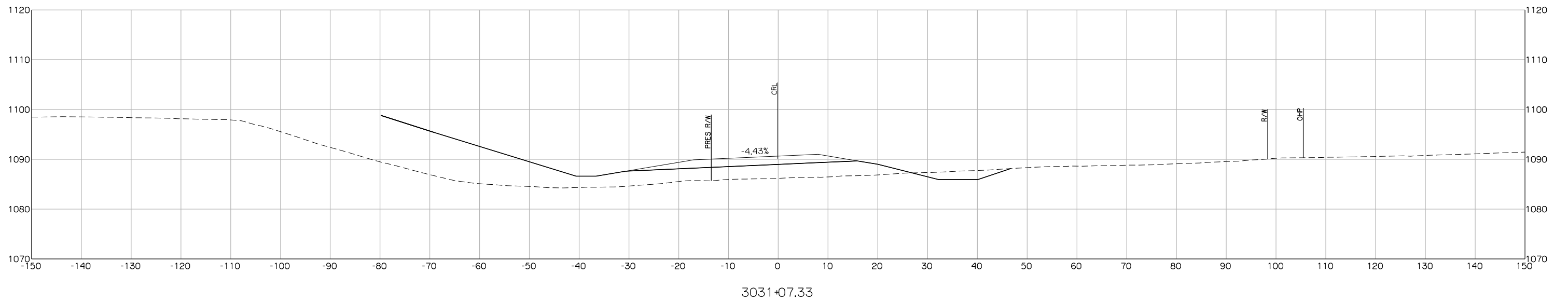
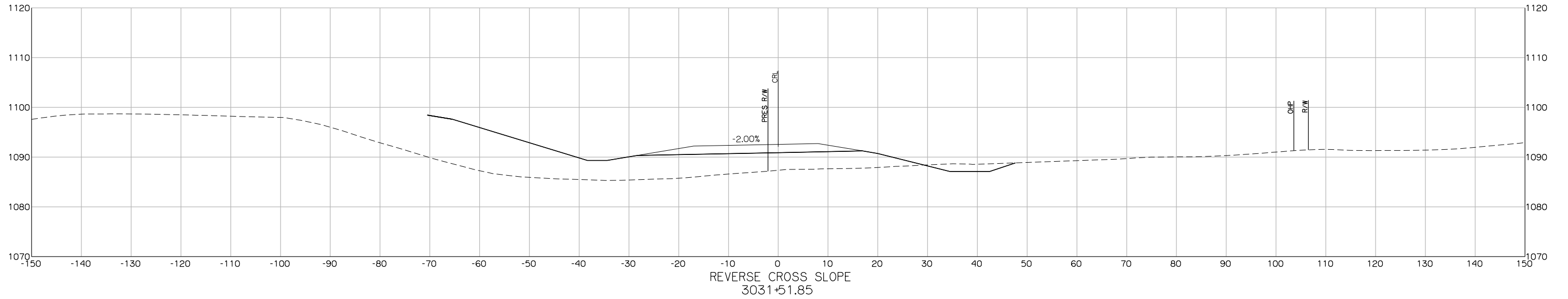

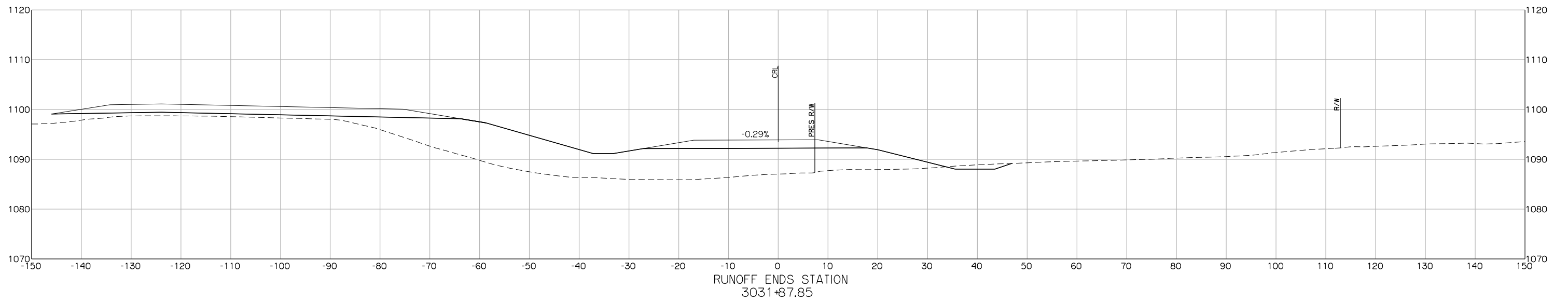
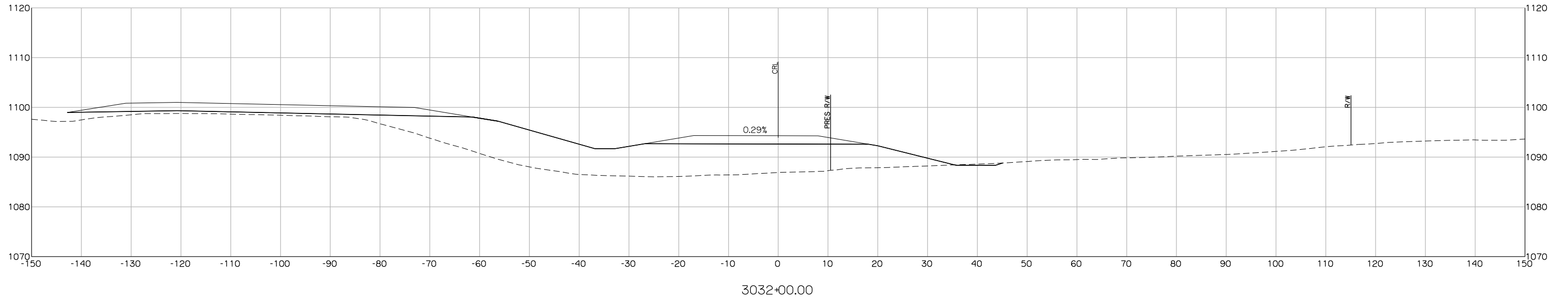

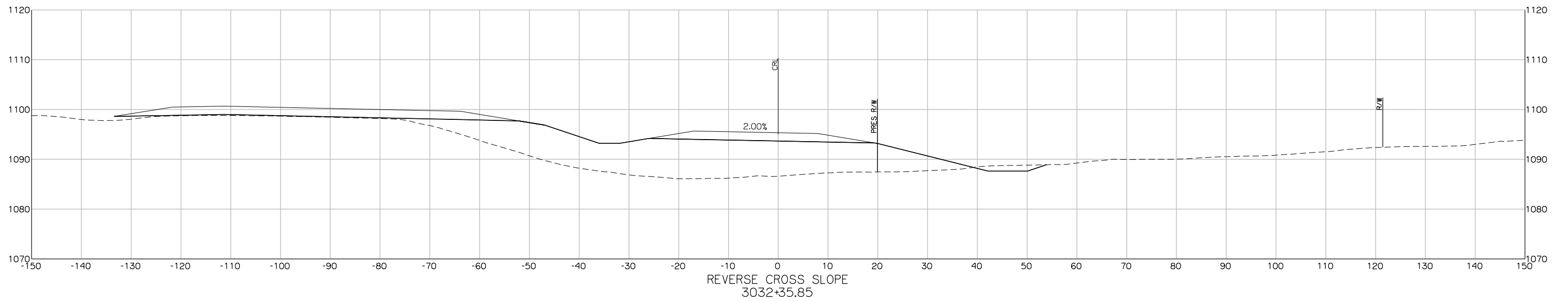
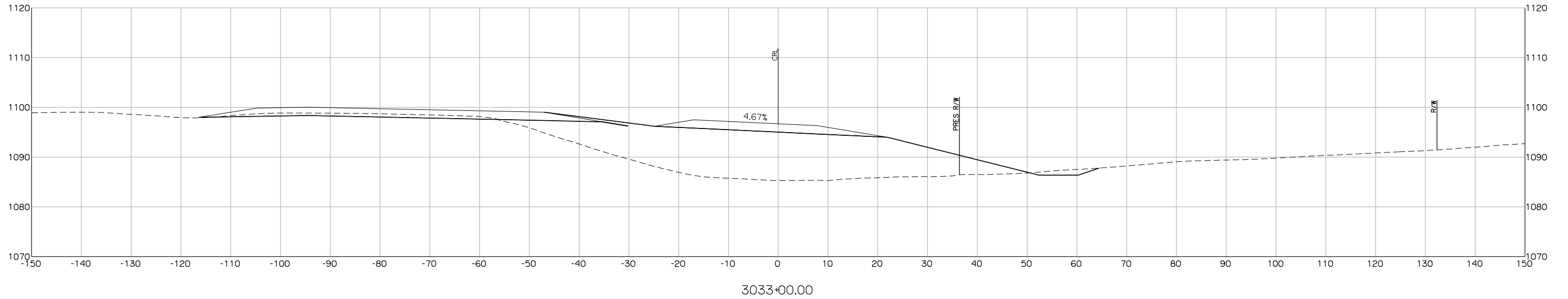

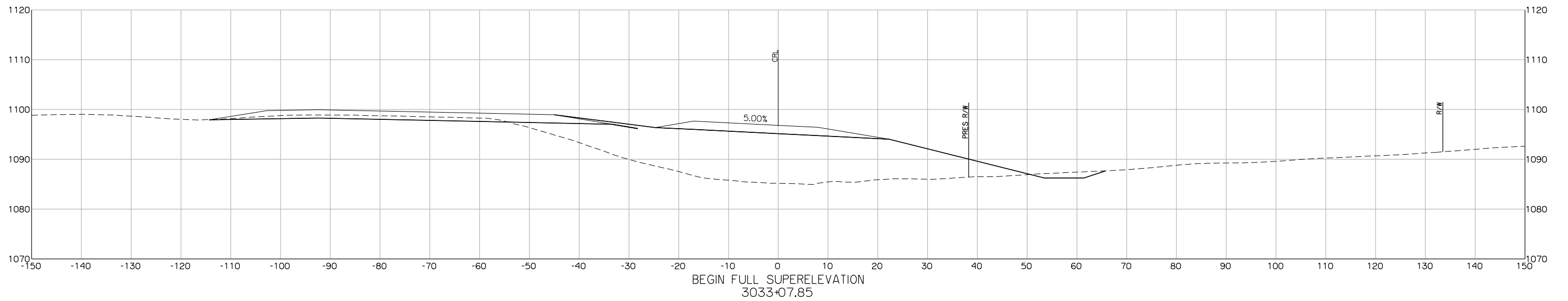
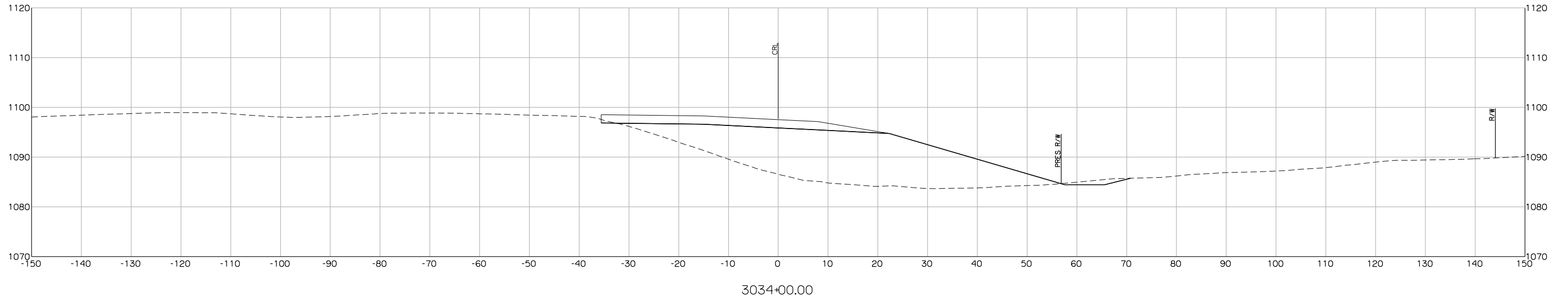

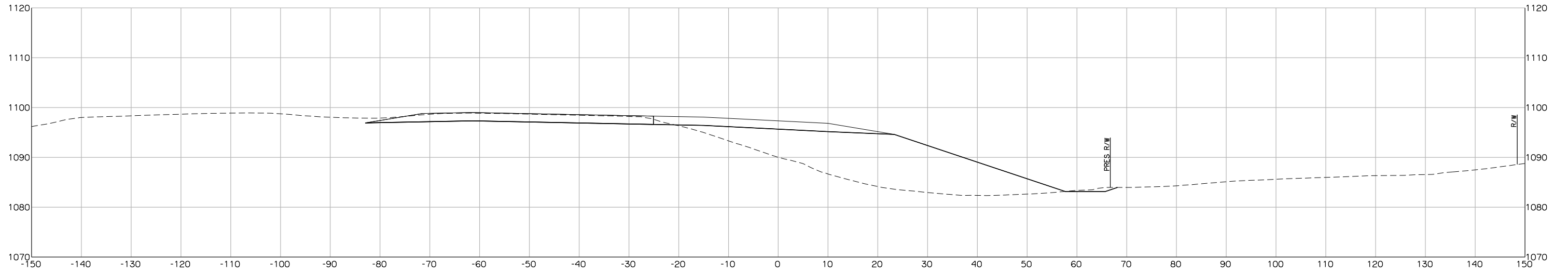

3034+66.74

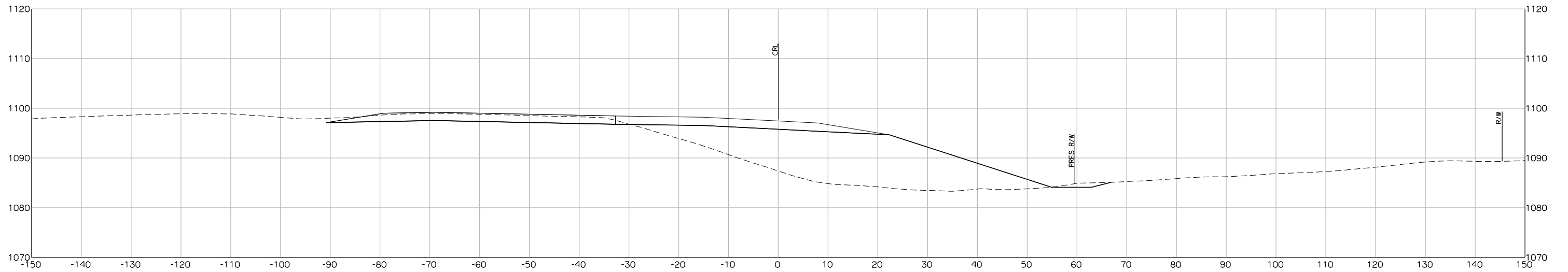

3034+16.71

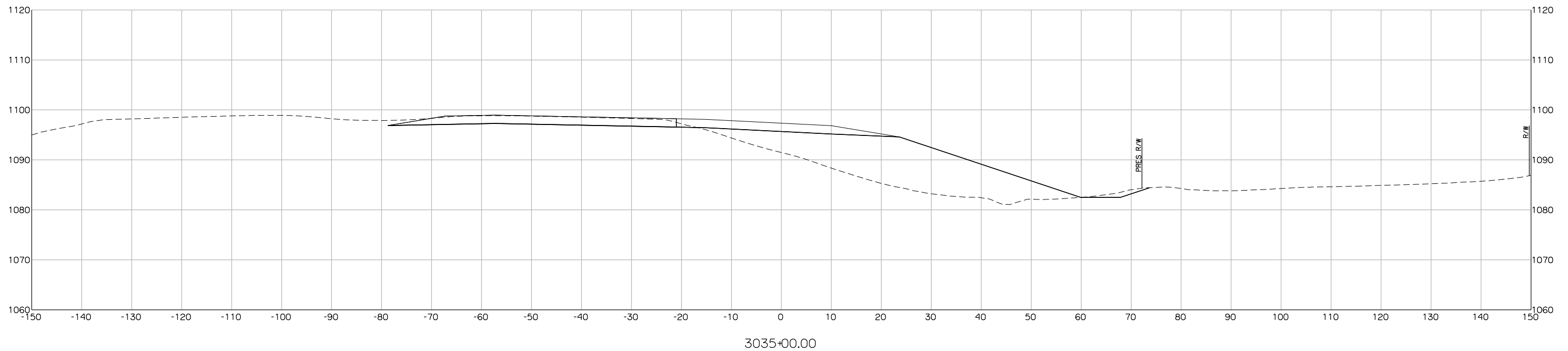
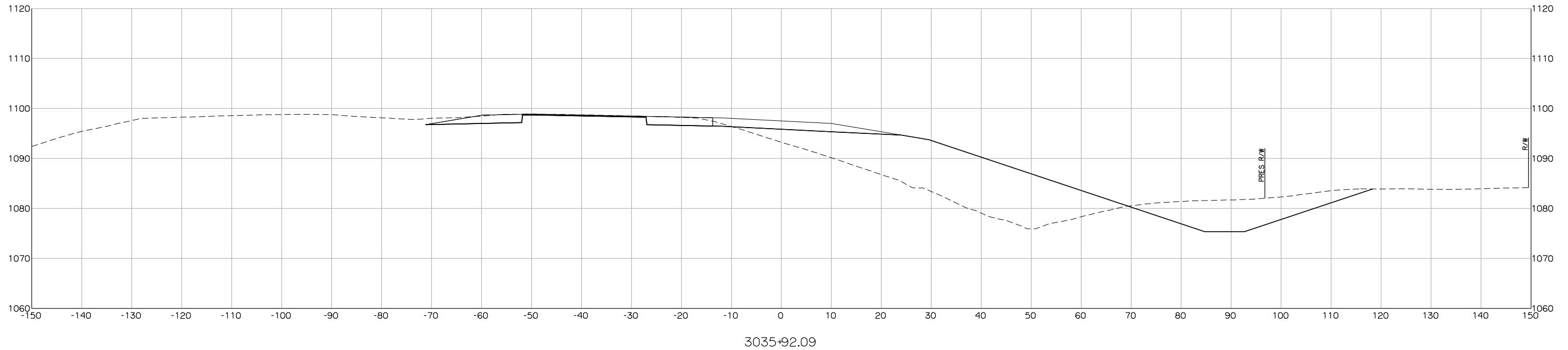

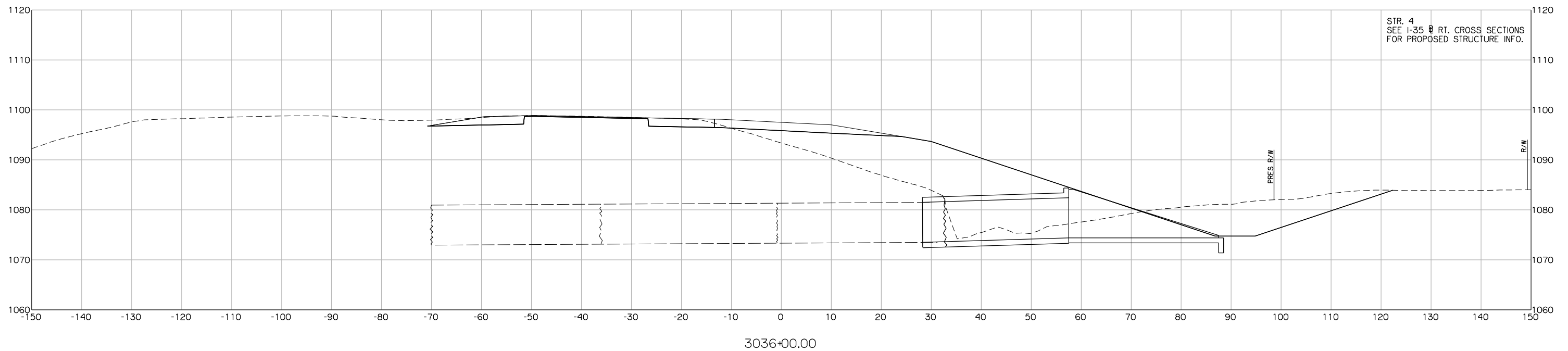
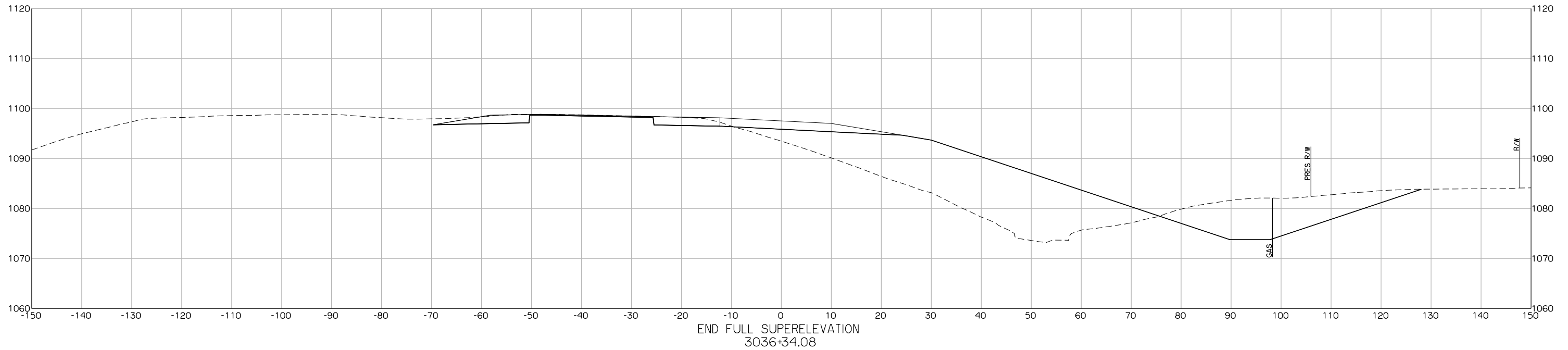

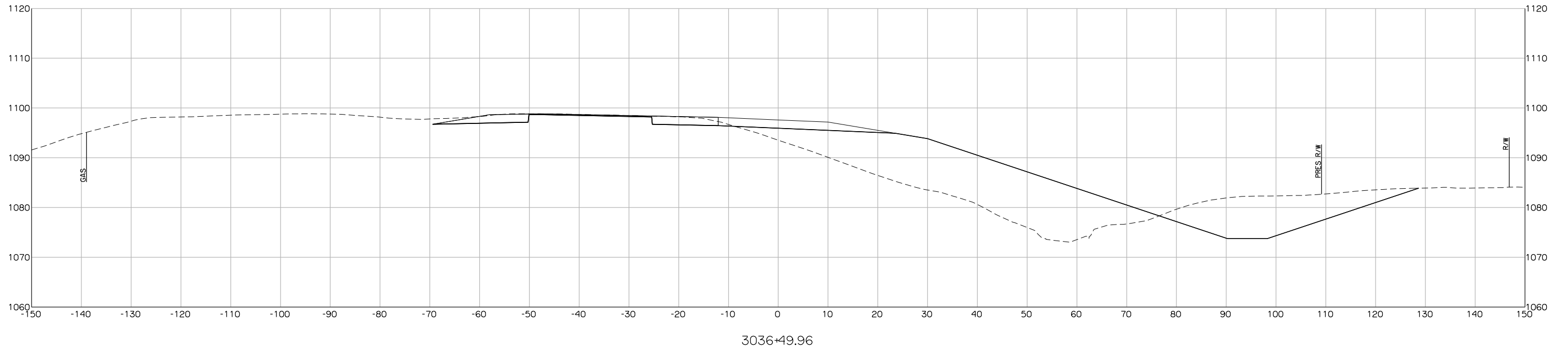

3036+49.96

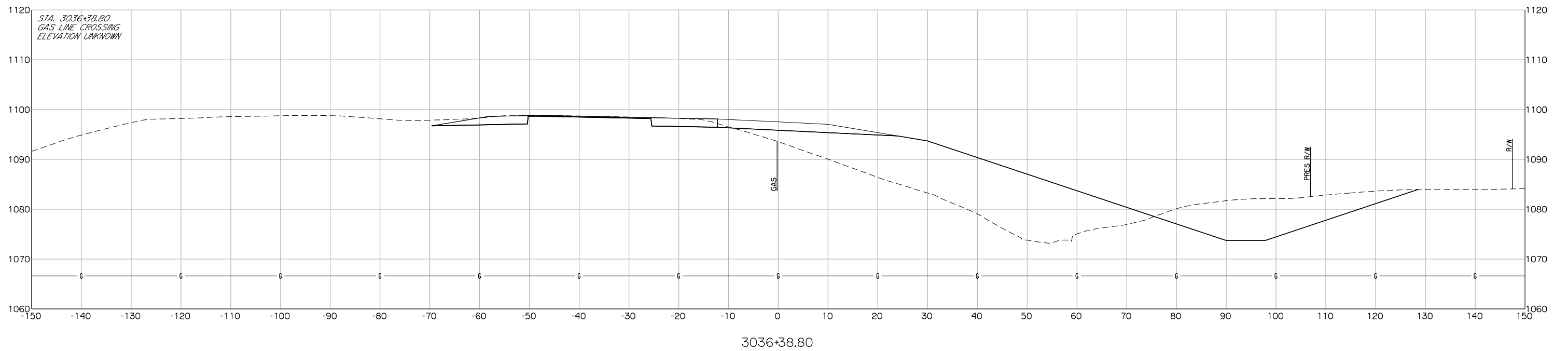

3036+38.80

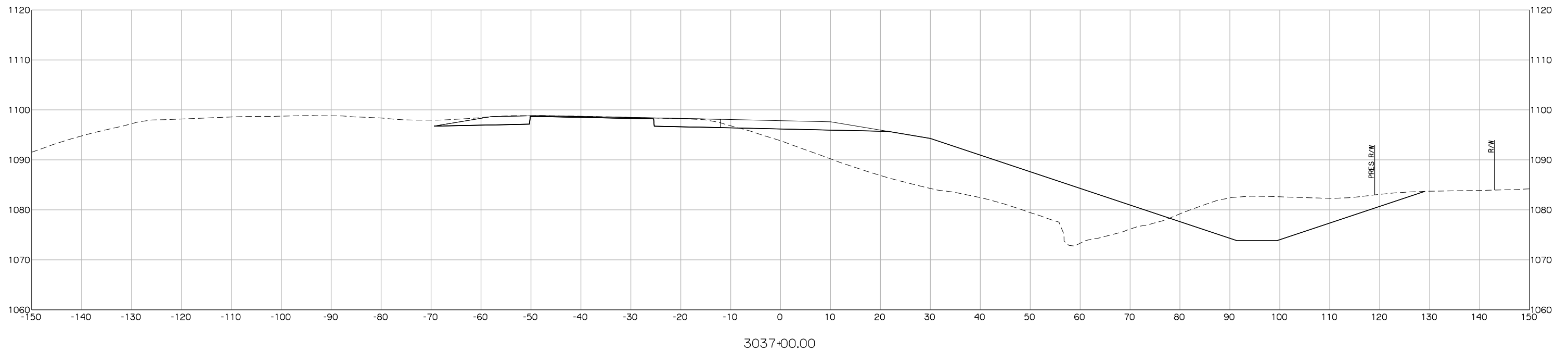
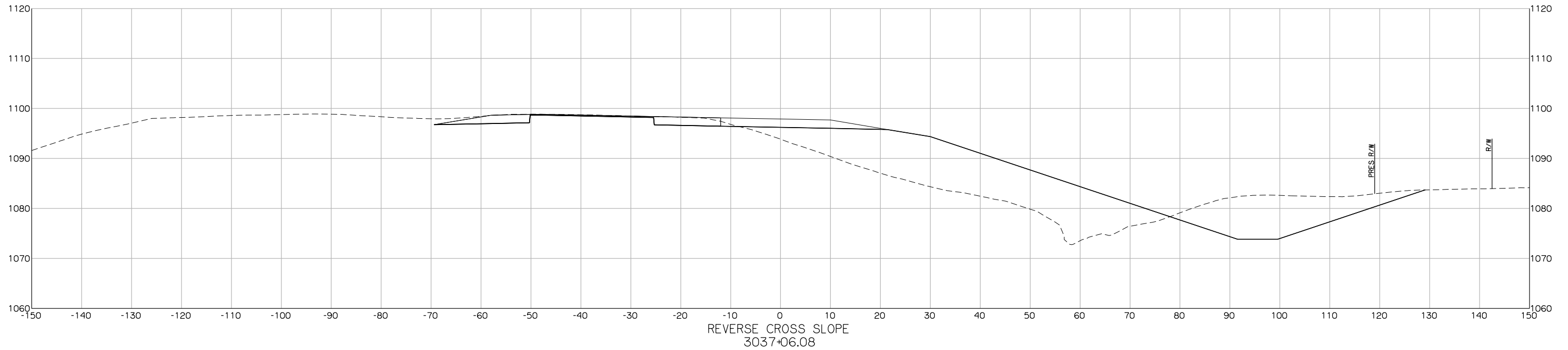

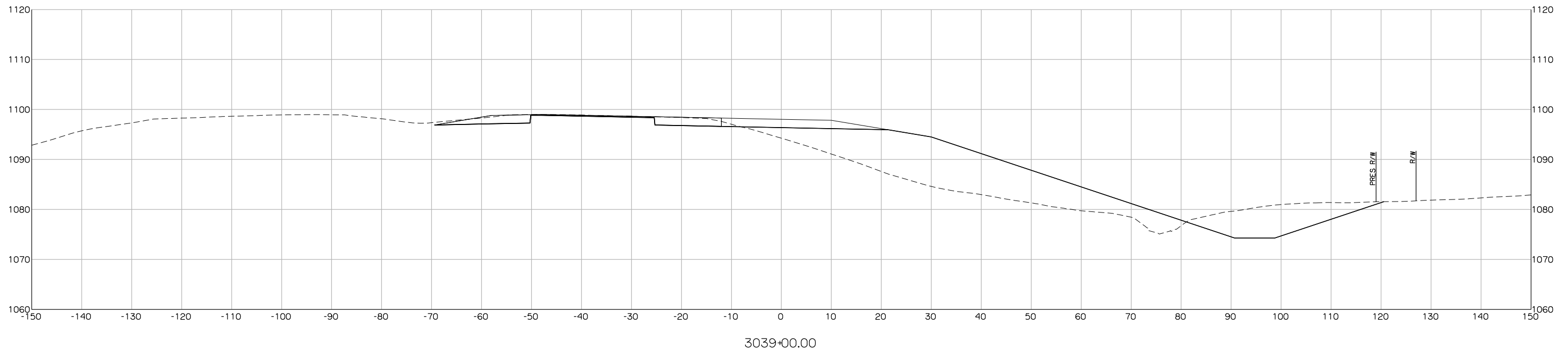

3039+00.00

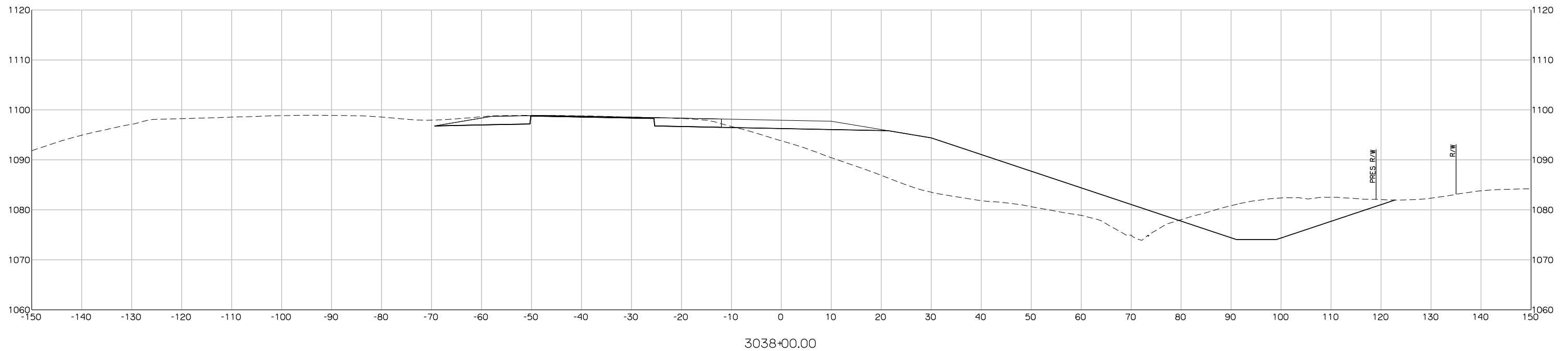

3038+00.00

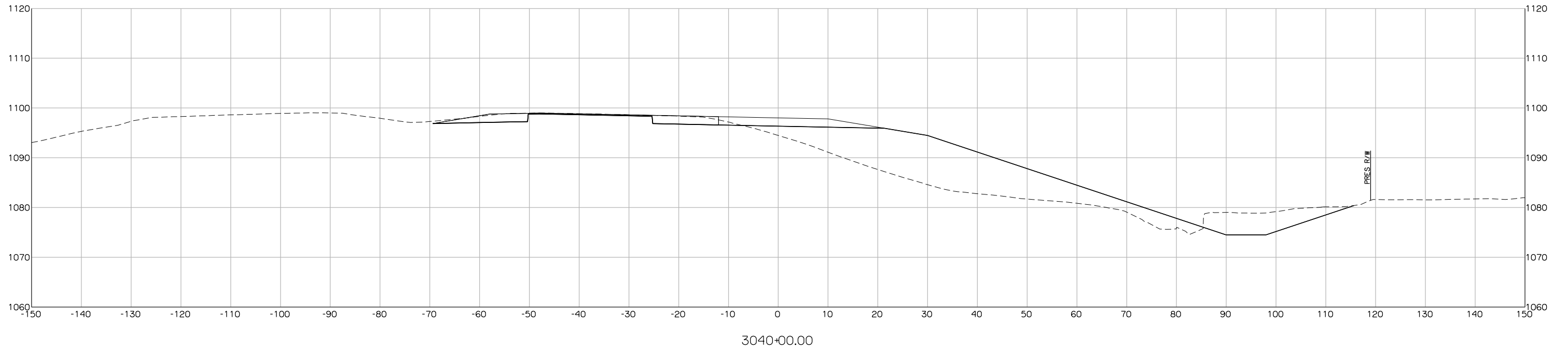

3040+00.00

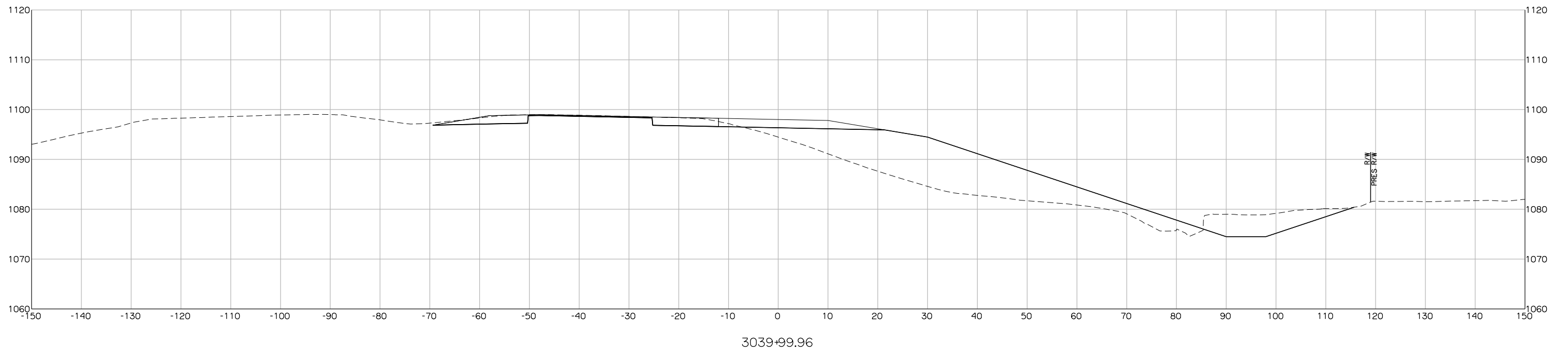

3039+99.96

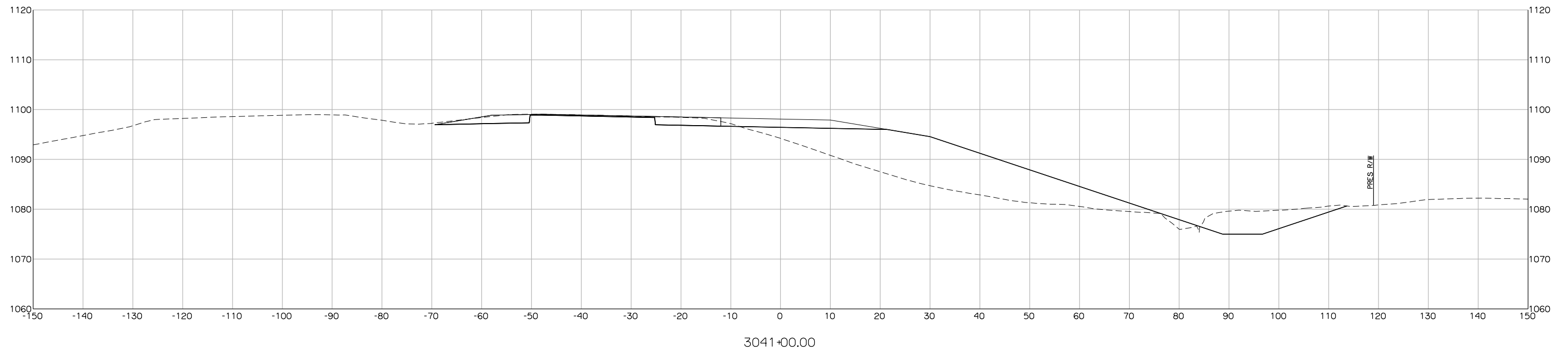
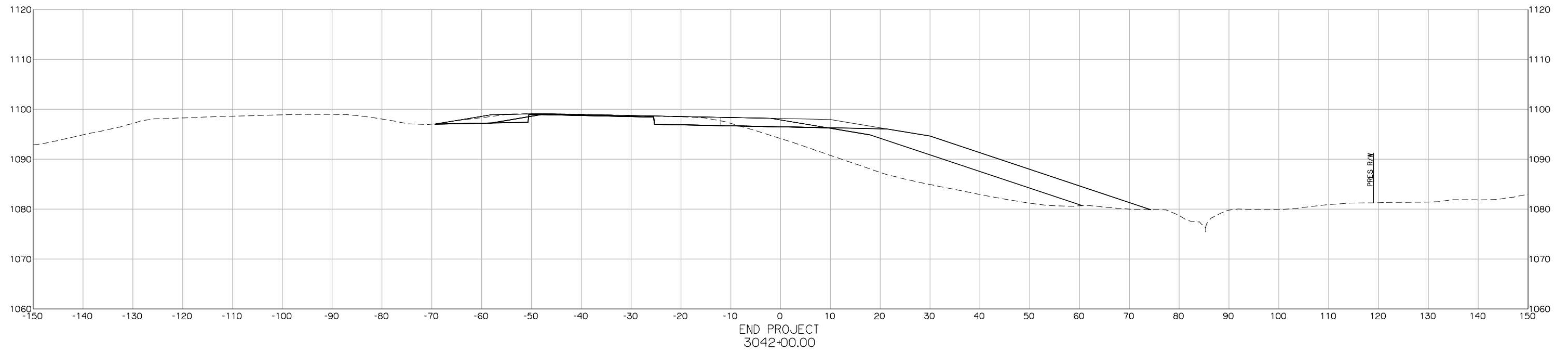

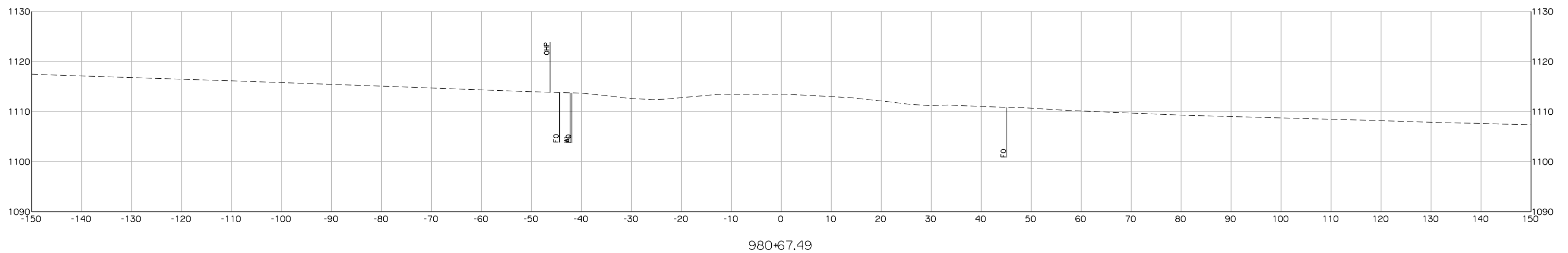
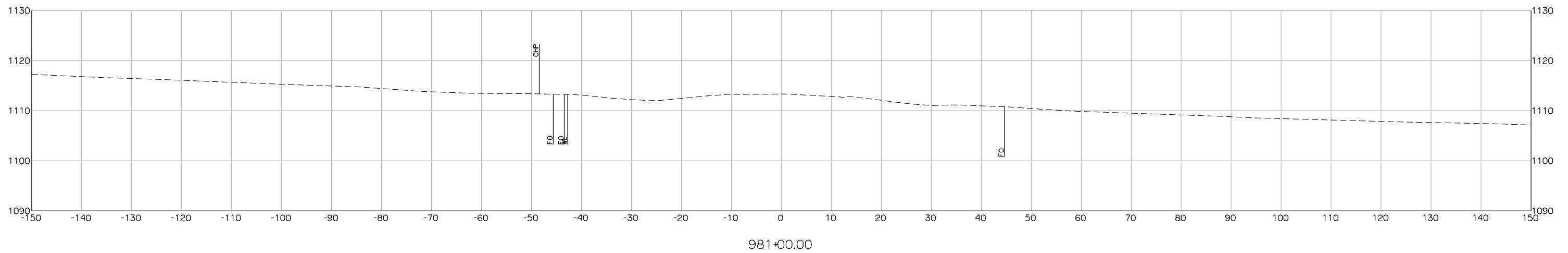
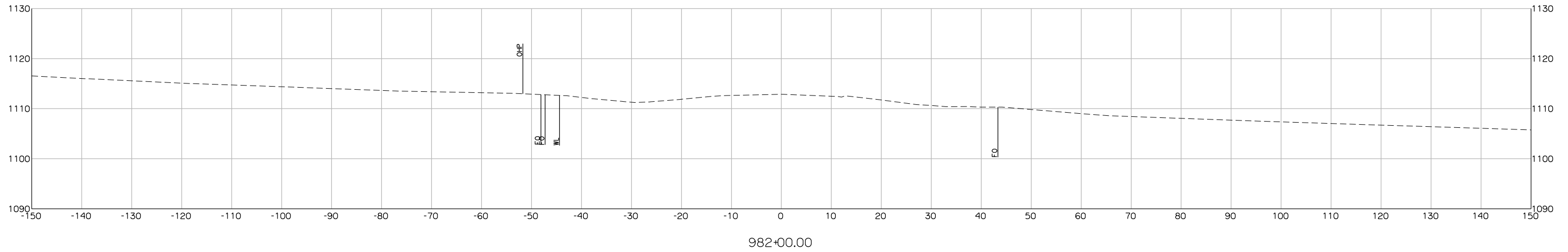

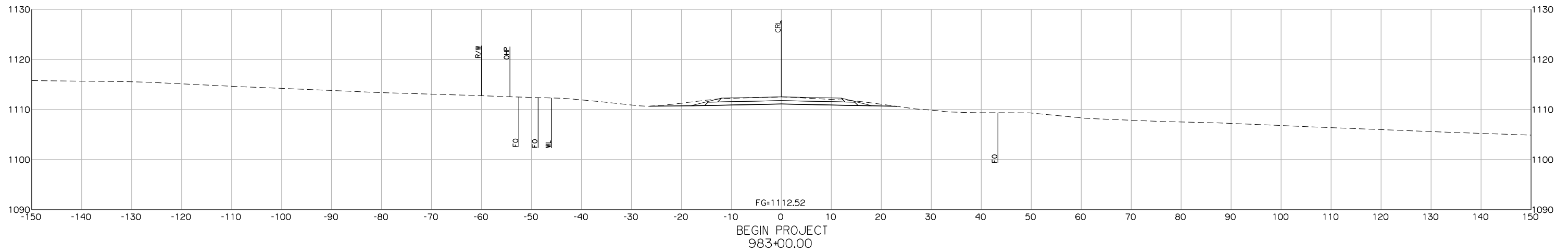
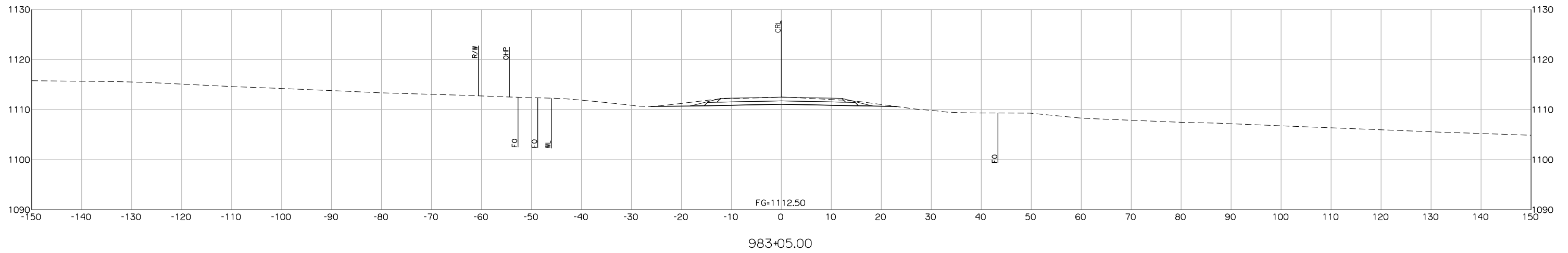
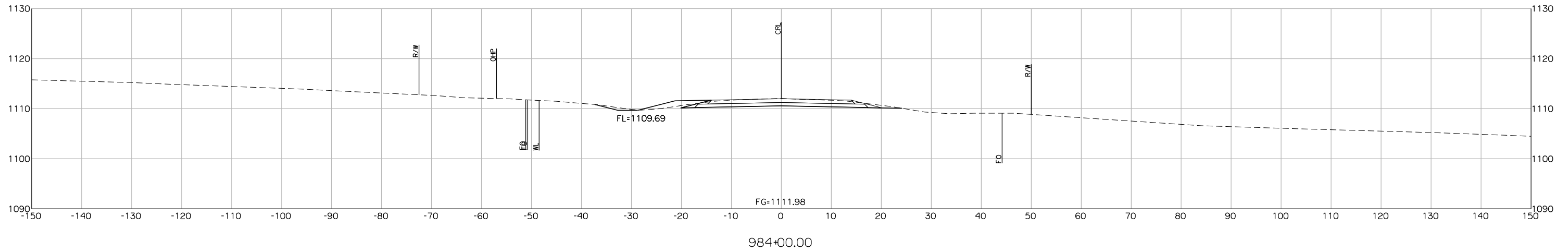

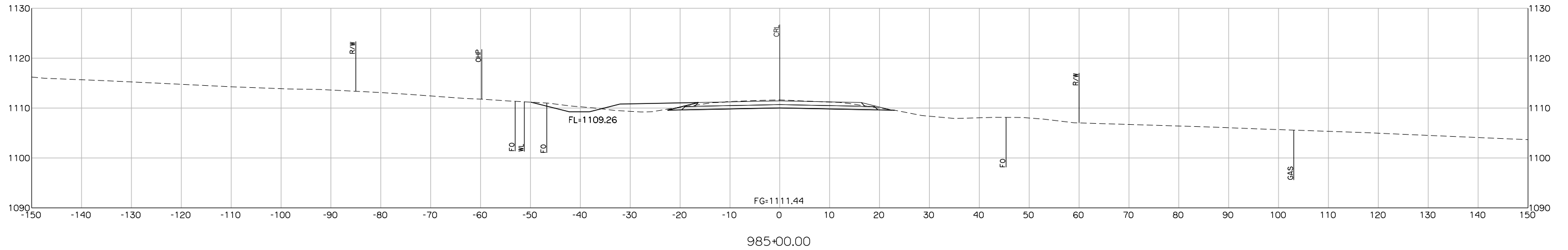
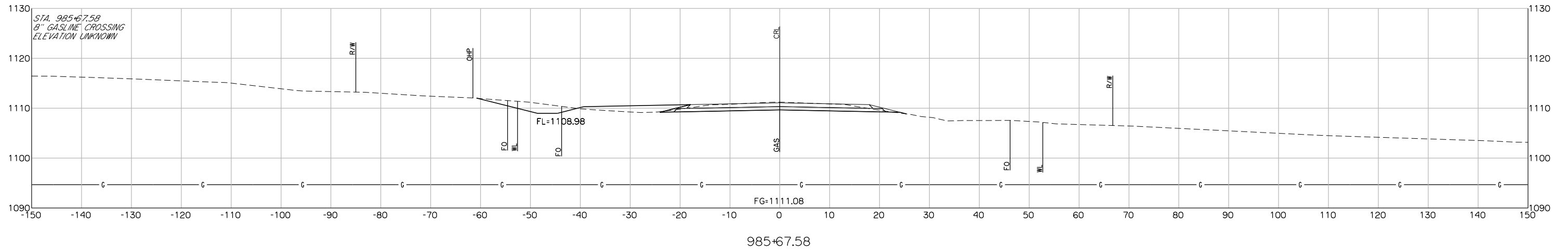
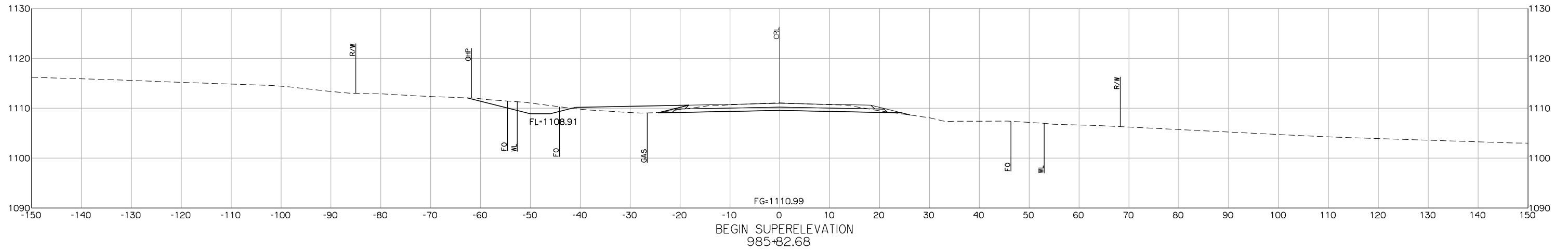

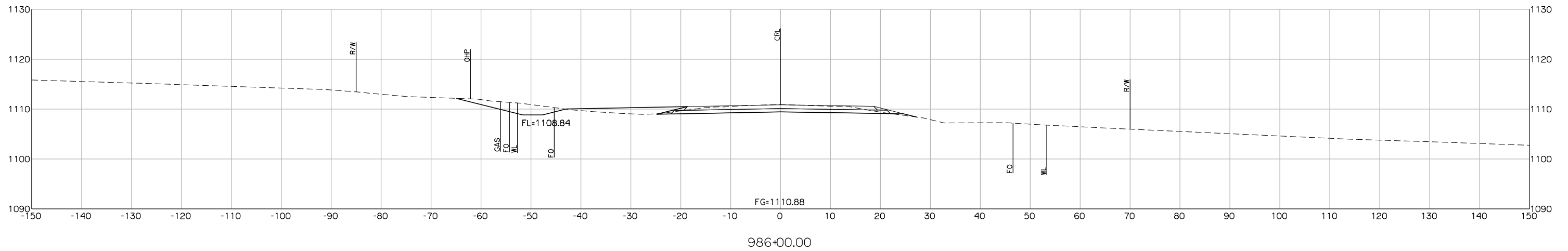
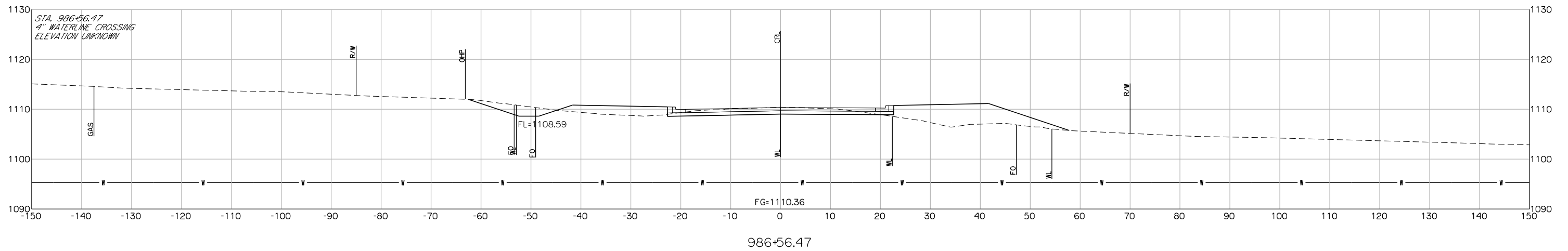
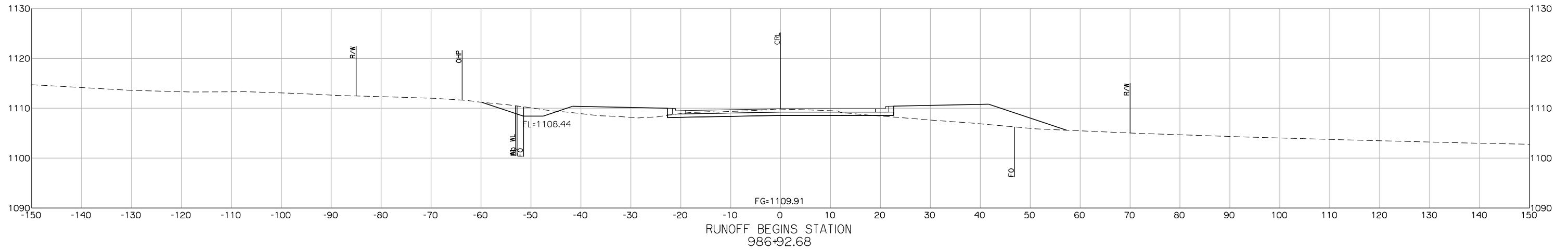

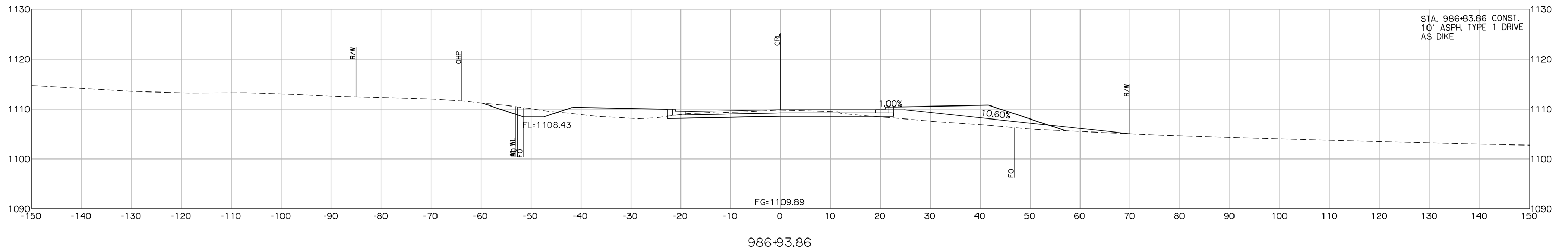
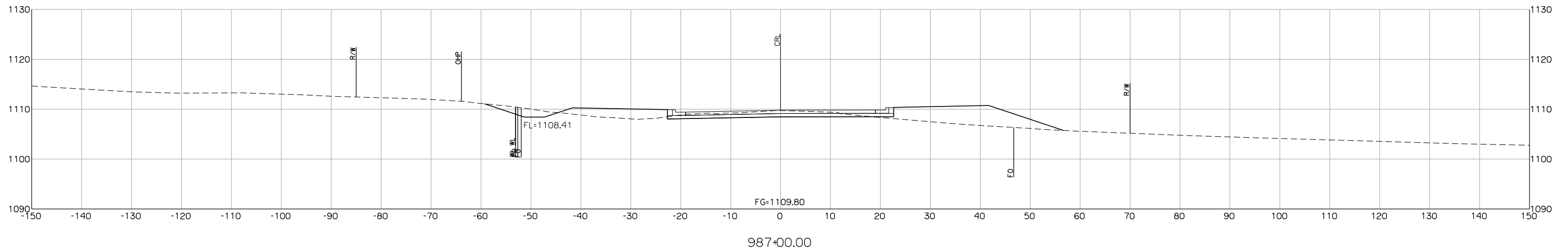
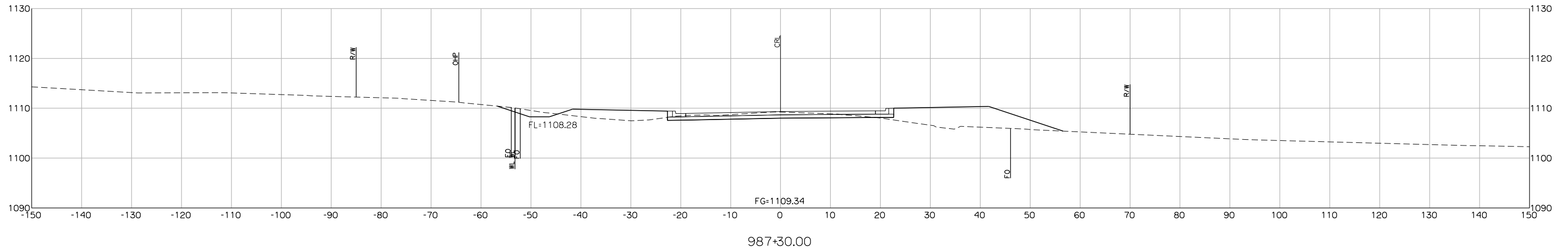

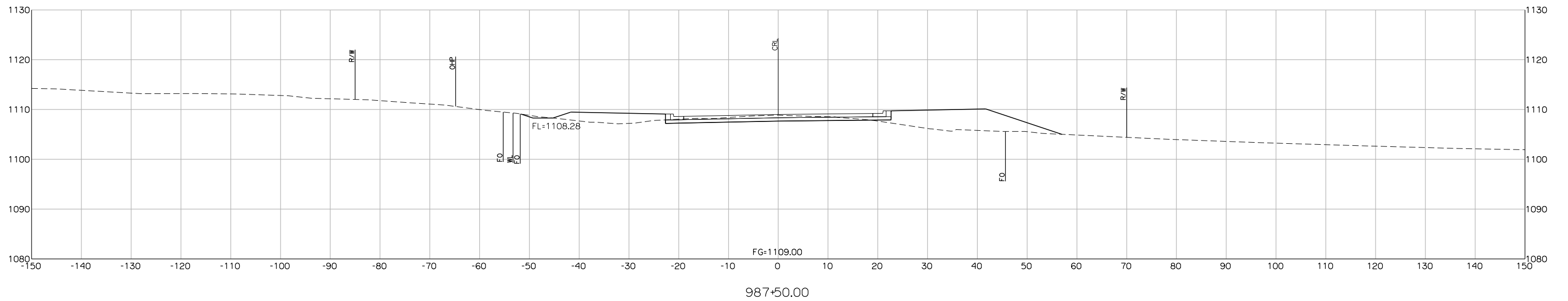
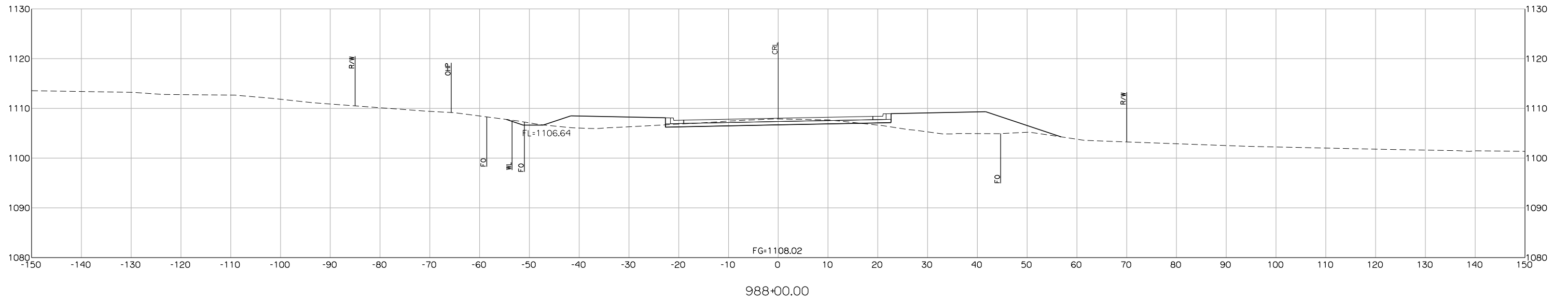

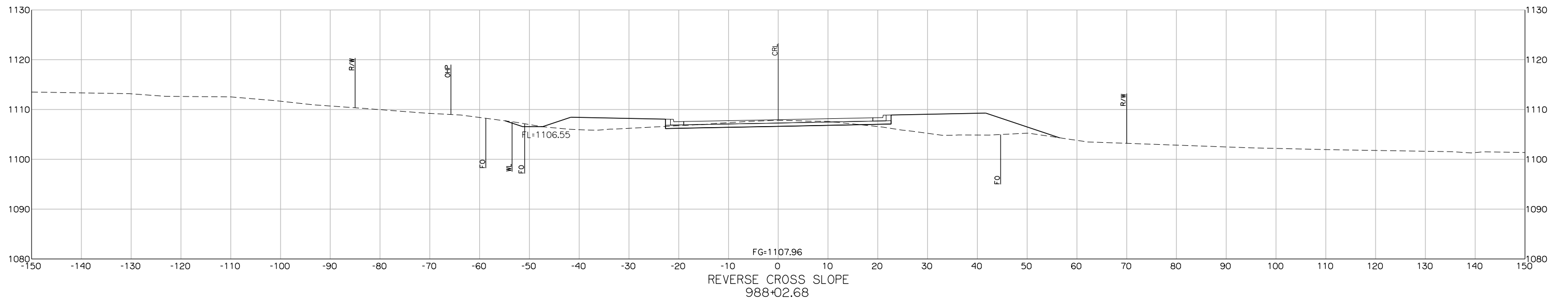
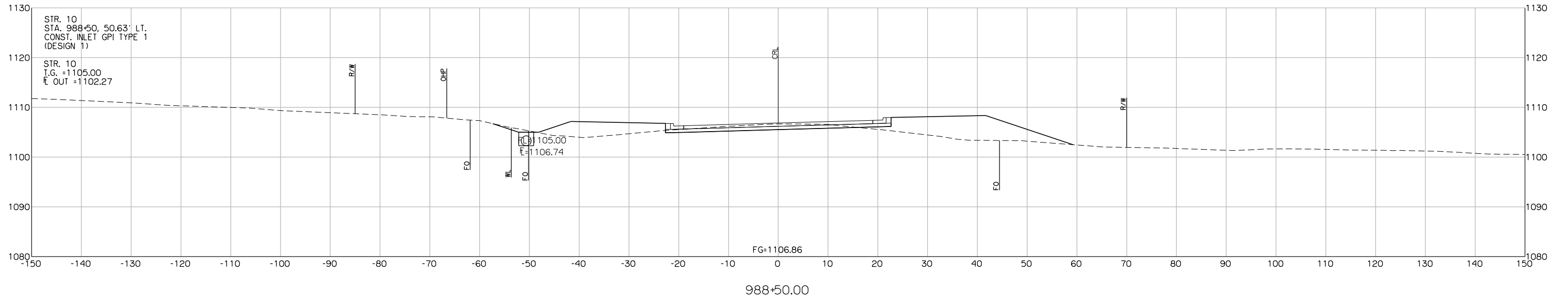

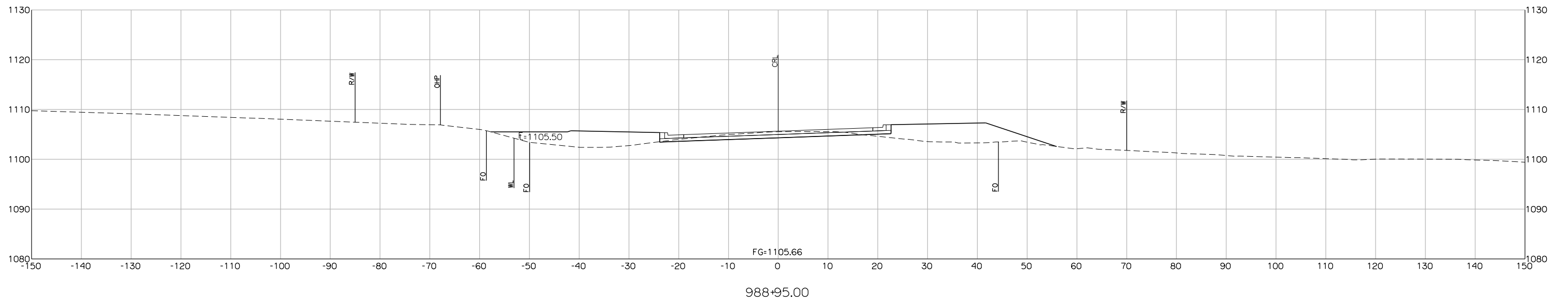
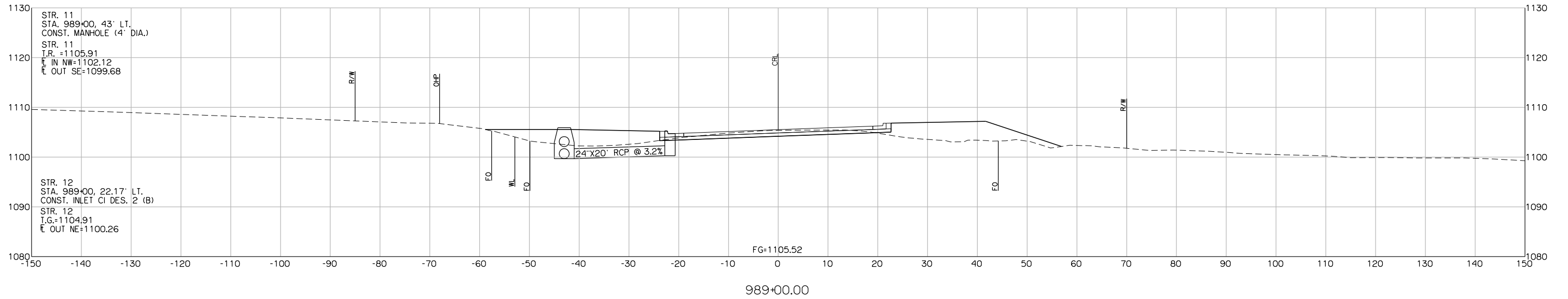

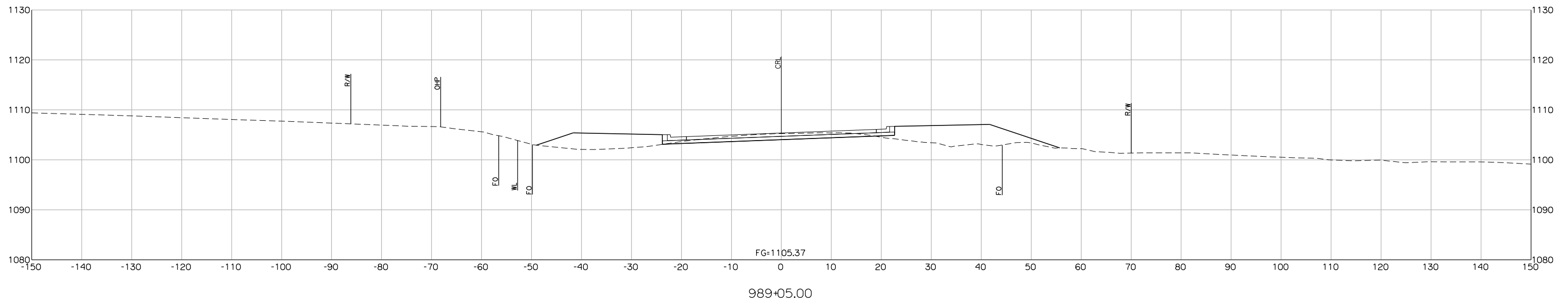
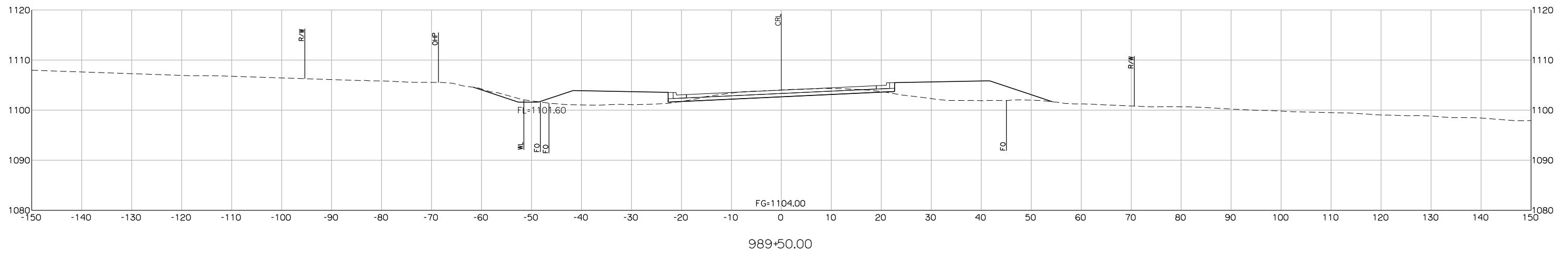
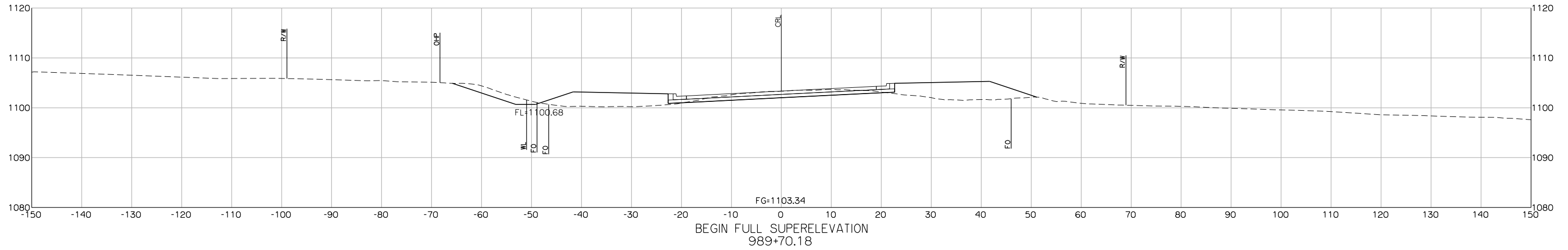

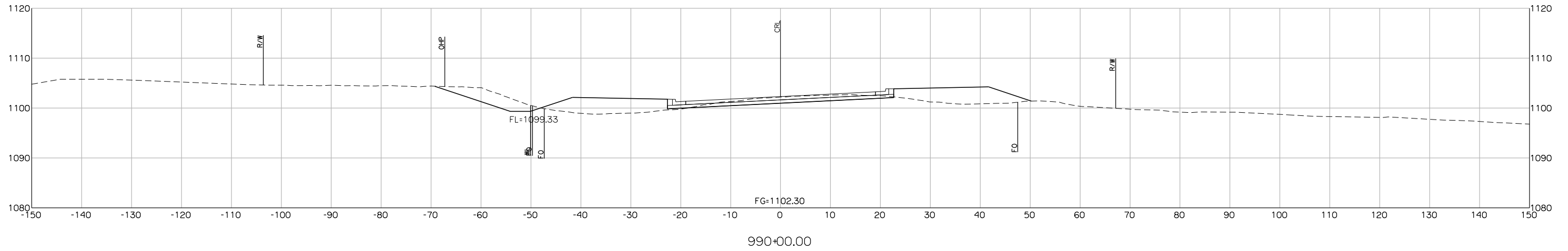
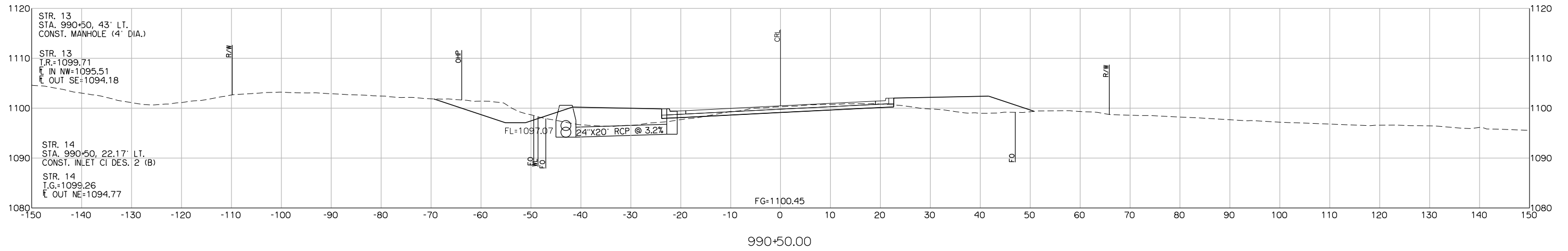
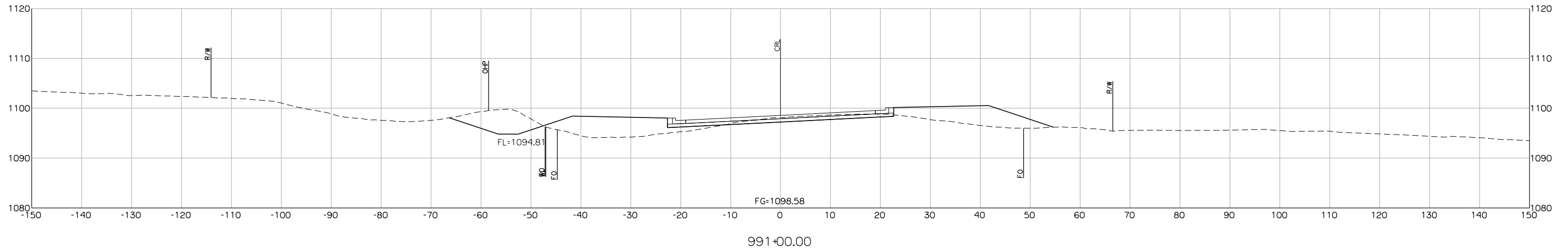

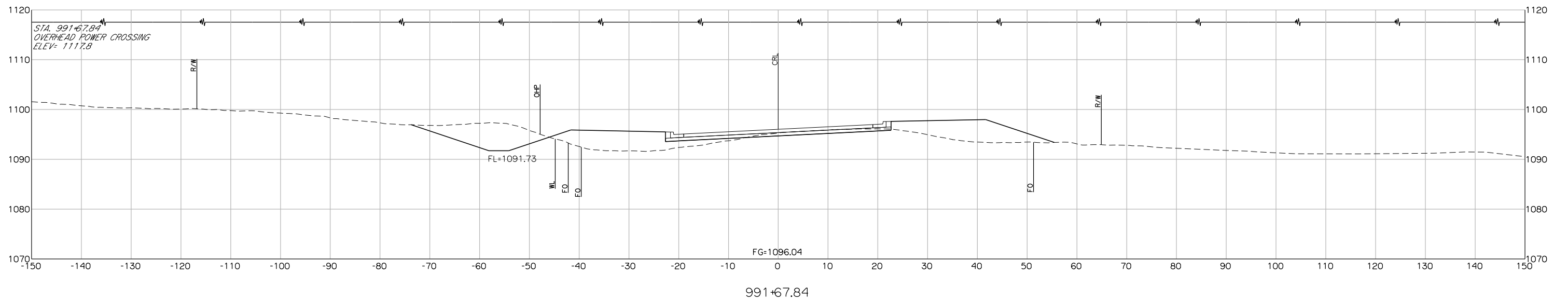
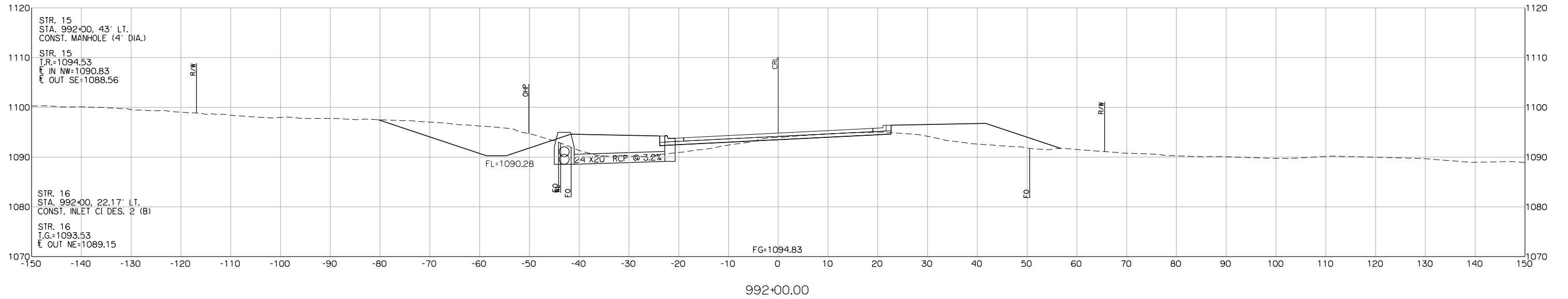
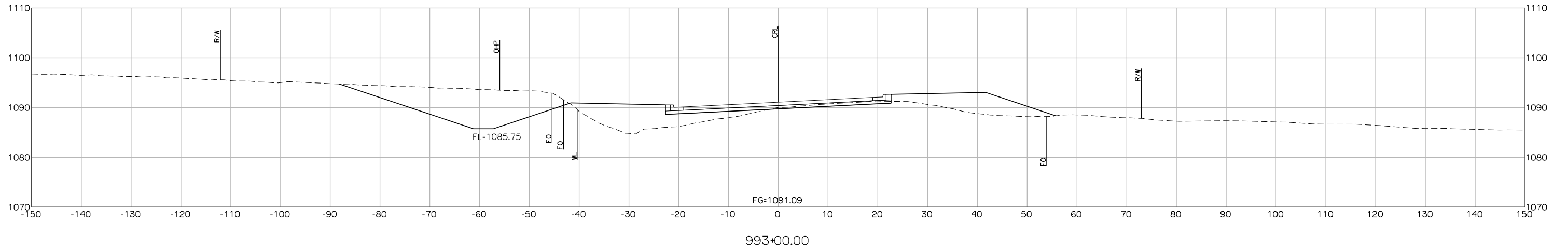

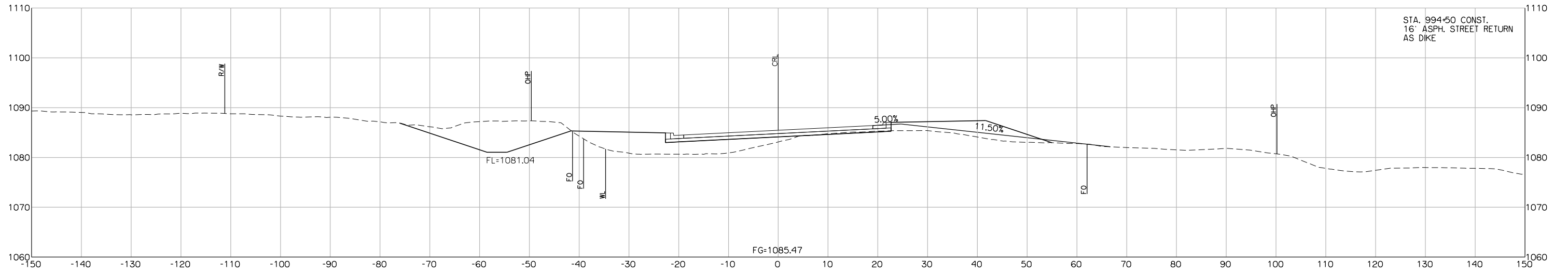

994+50.00

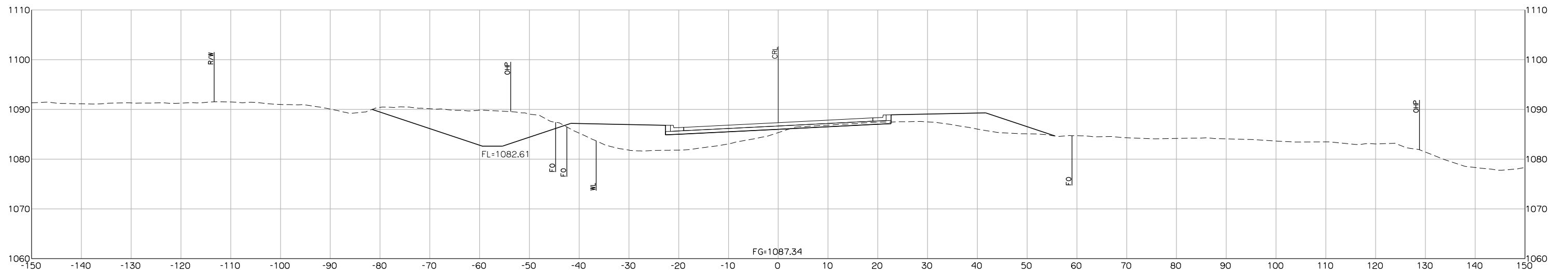

994+00.00

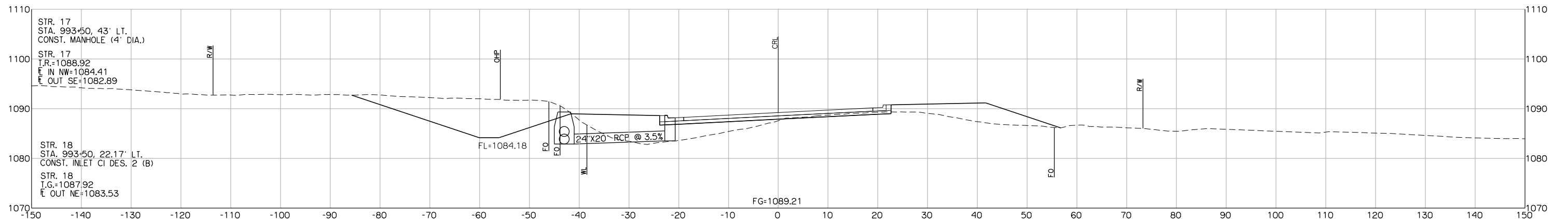

993+50.00

STR. 17
STA. 993+50, 43' LT.
CONST. MANHOLE (4' DIA.)

STR. 17
I.R.=1088.92
E IN NW=1084.41
E OUT SE=1082.89

STR. 18
STA. 993+50, 22.17' LT.
CONST. INLET CI DES. 2 (B)

STR. 18
I.G.=1087.92
E OUT NE=1083.53

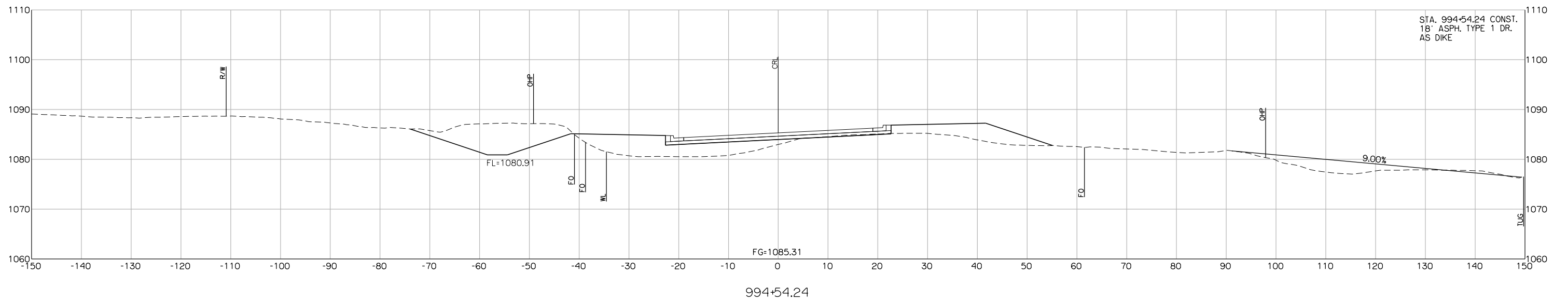
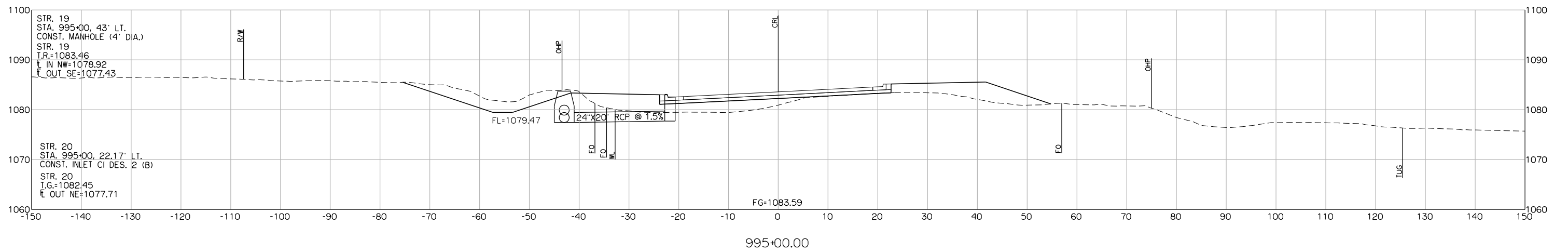
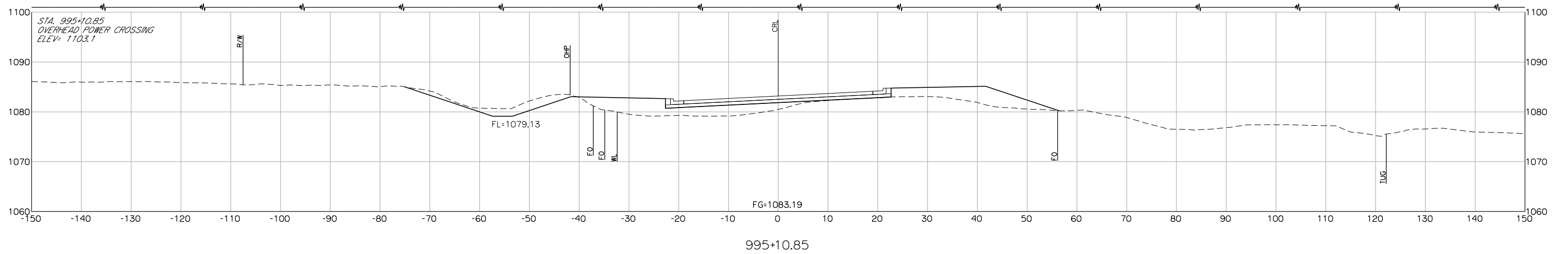

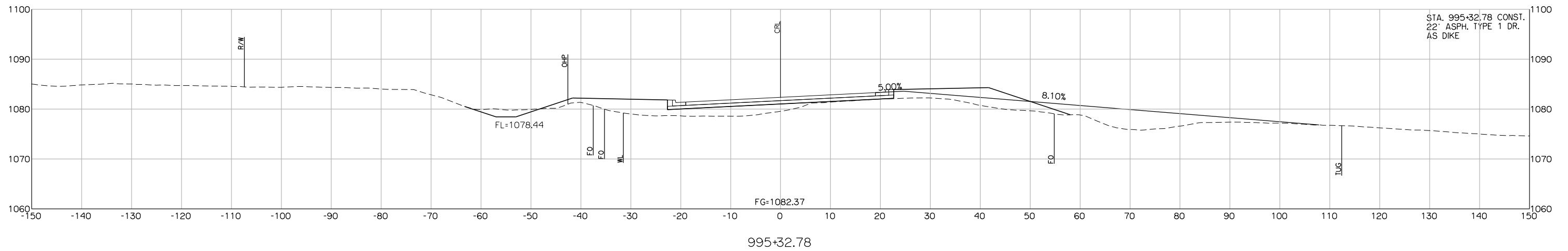
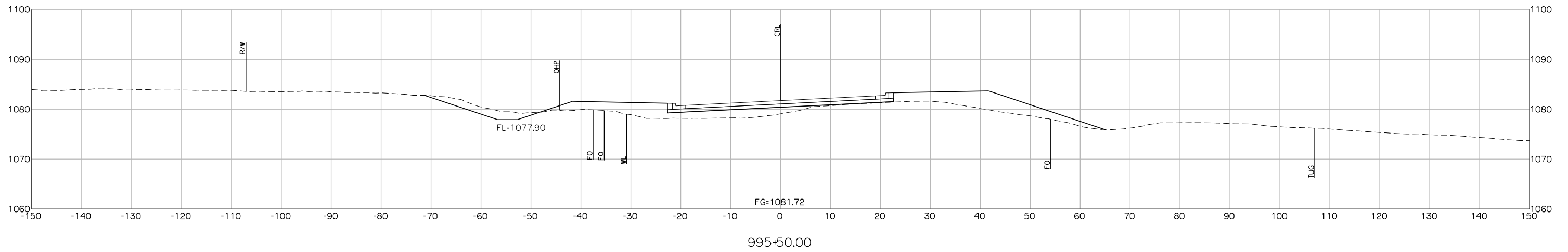
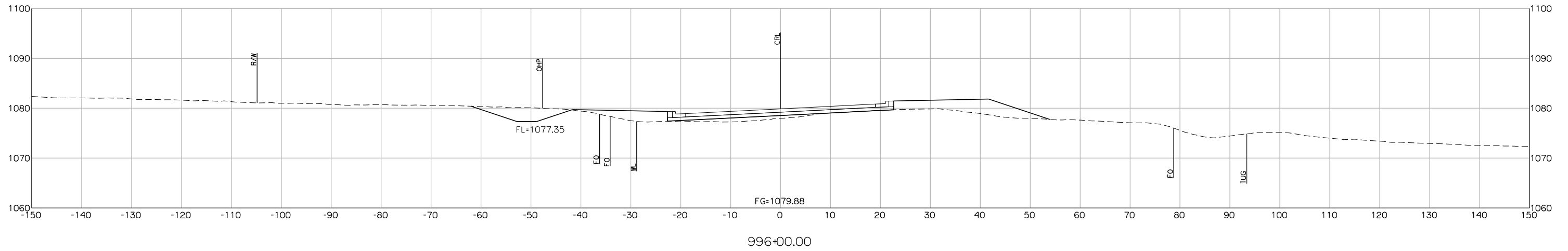

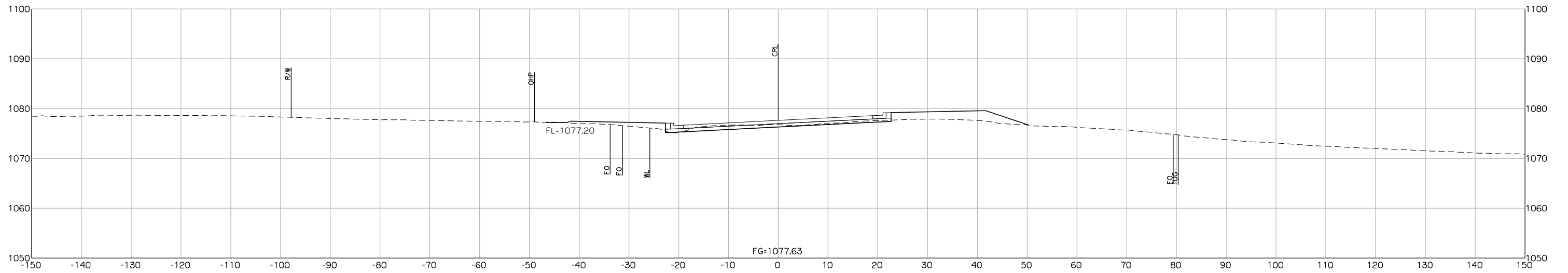

996+75.00

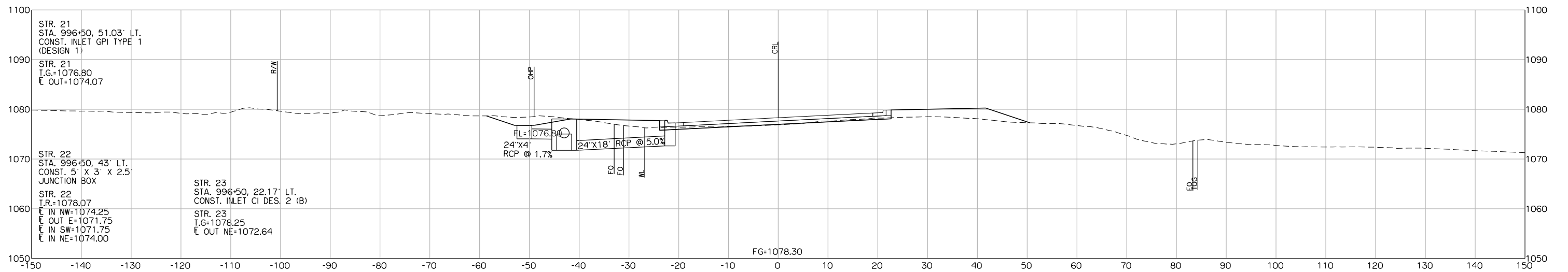

996+50.00

STR. 21
STA. 996+50, 51.03' LT.
CONST. INLET GPI TYPE 1
(DESIGN 1)

STR. 21
I.G.=1076.80
E OUT=1074.07

STR. 22
STA. 996+50, 43' LT.
CONST. 5' X 3' X 2.5'
JUNCTION BOX

STR. 22
I.R.=1078.07
E IN NW=1074.25
E OUT E=1071.75
E IN SW=1071.75
E IN NE=1074.00

STR. 23
STA. 996+50, 22.17' LT.
CONST. INLET CI DES. 2 (B)

STR. 23
I.G.=1076.25
E OUT NE=1072.64

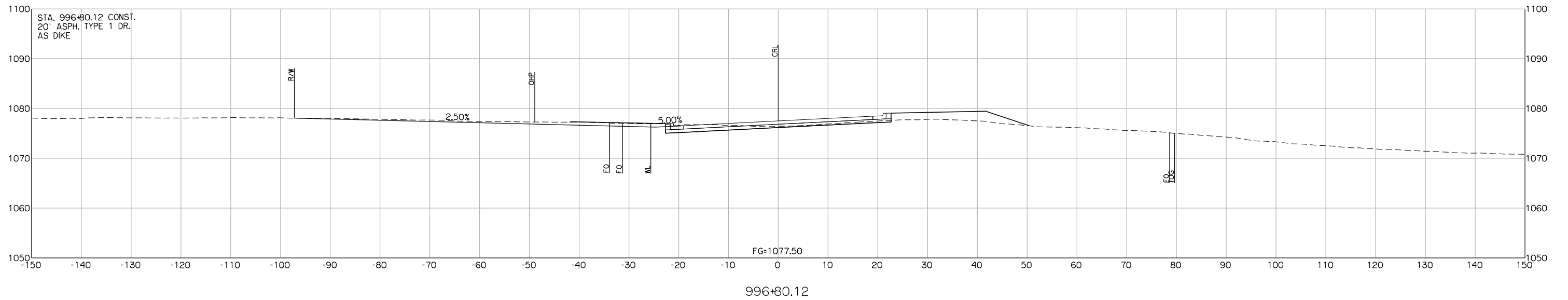
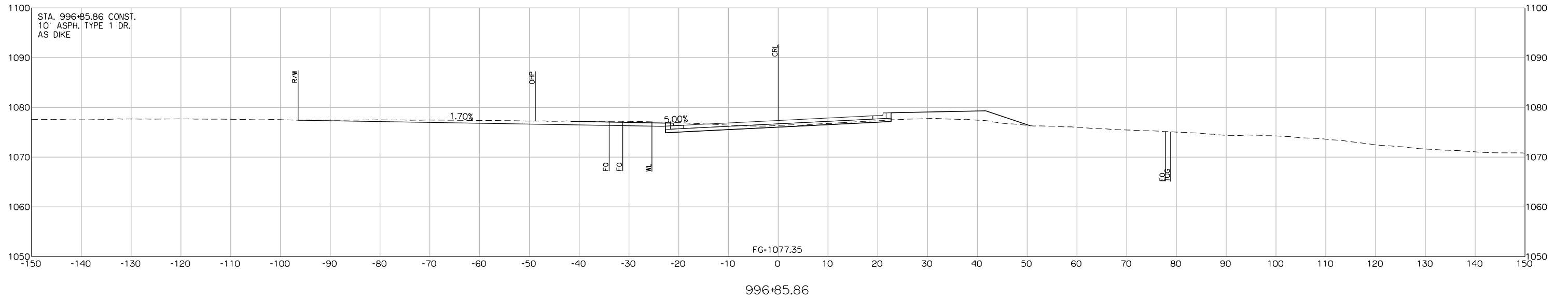
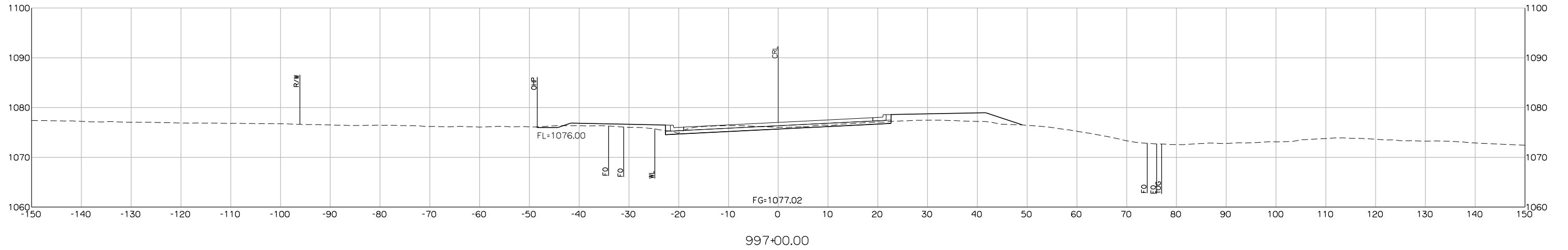

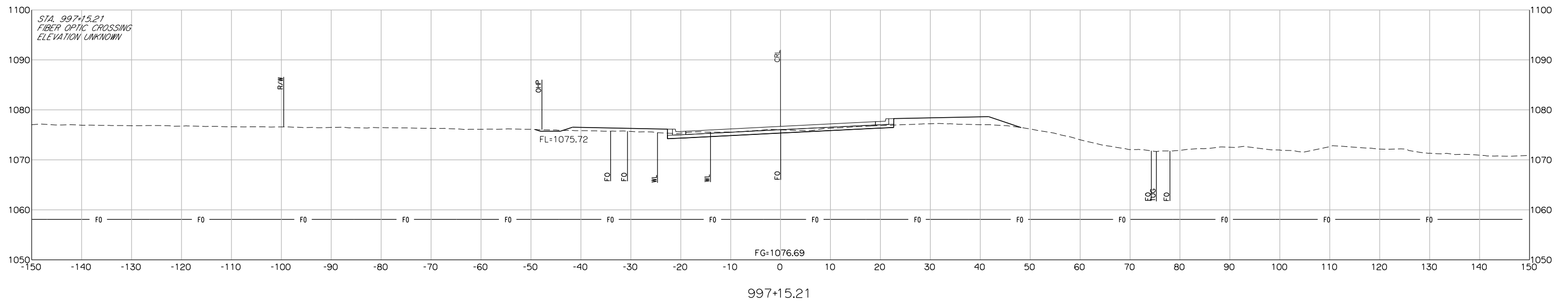
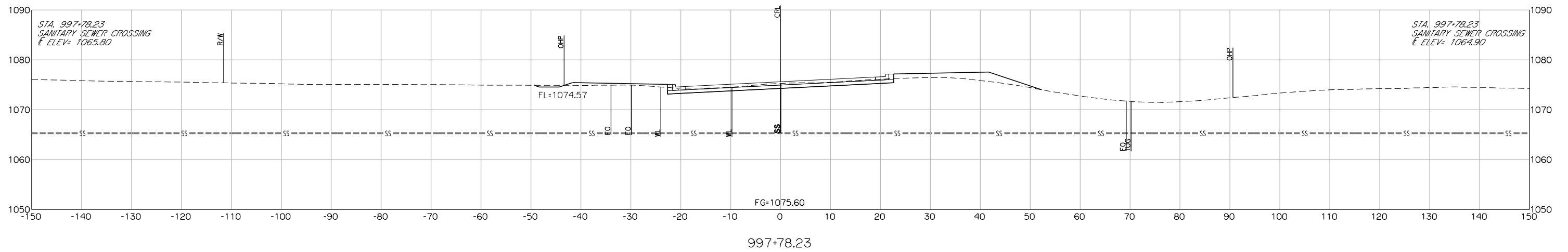
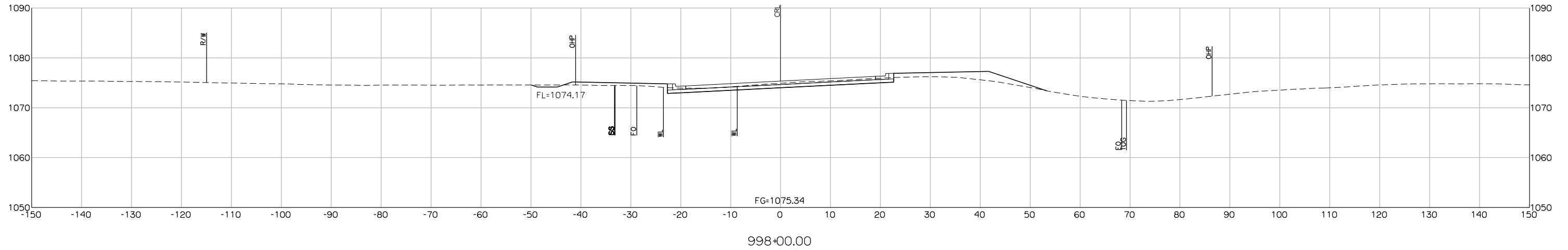

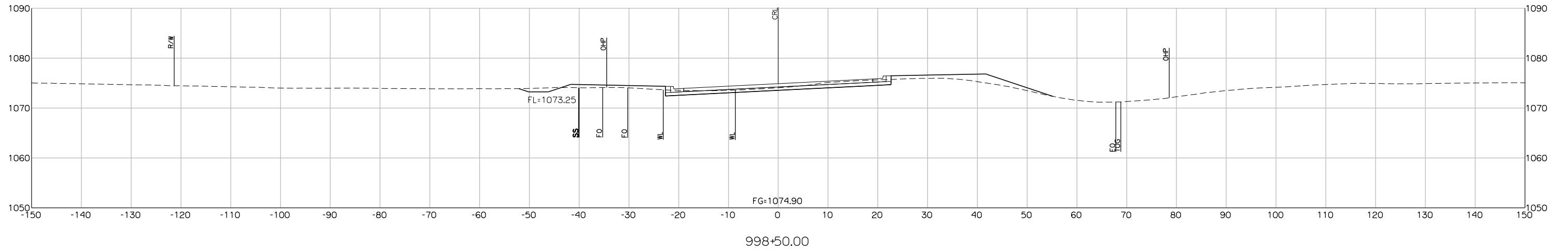
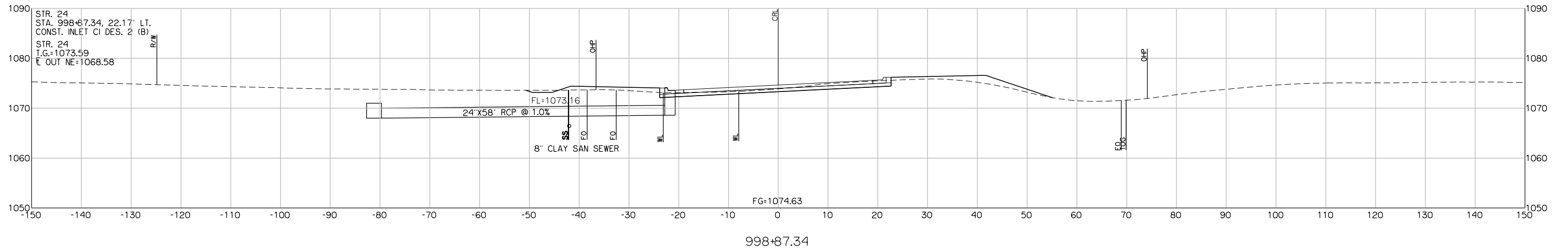
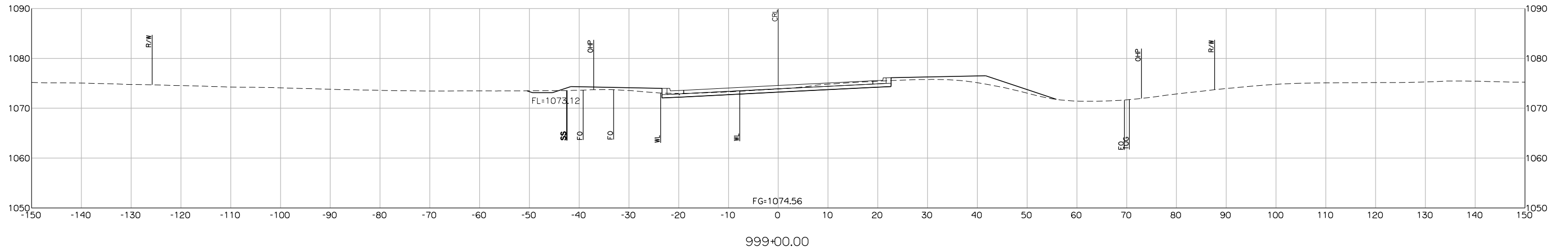

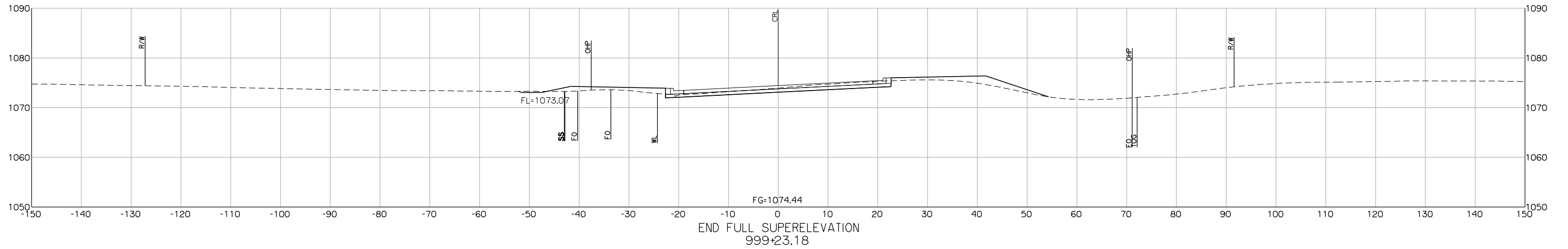
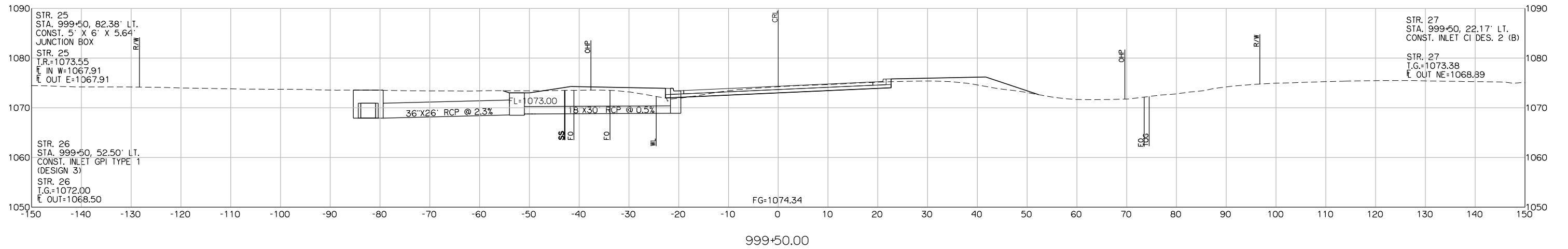
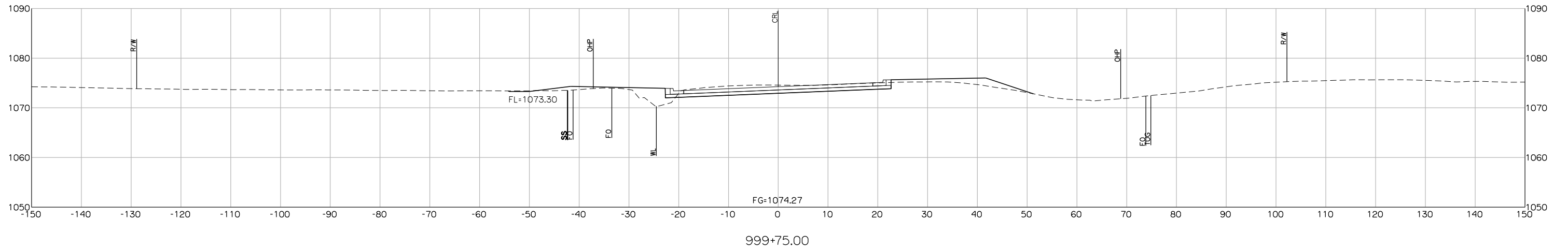

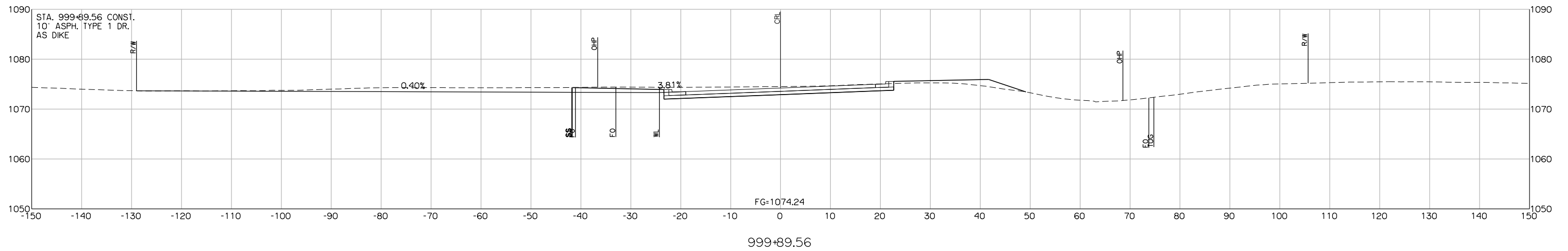
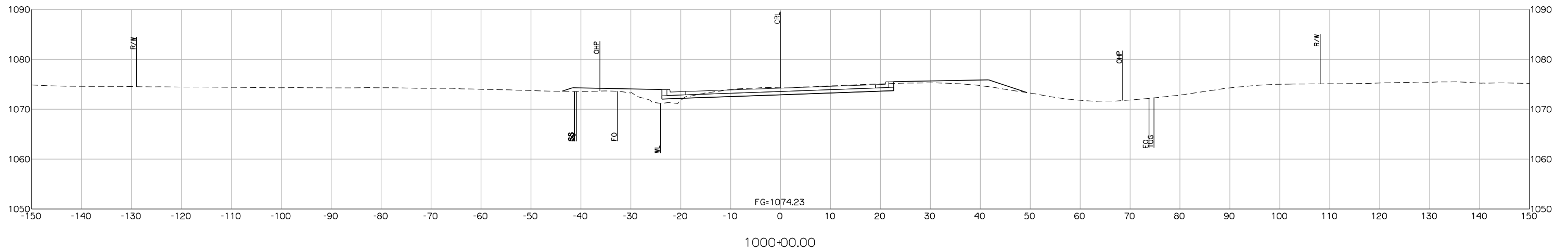
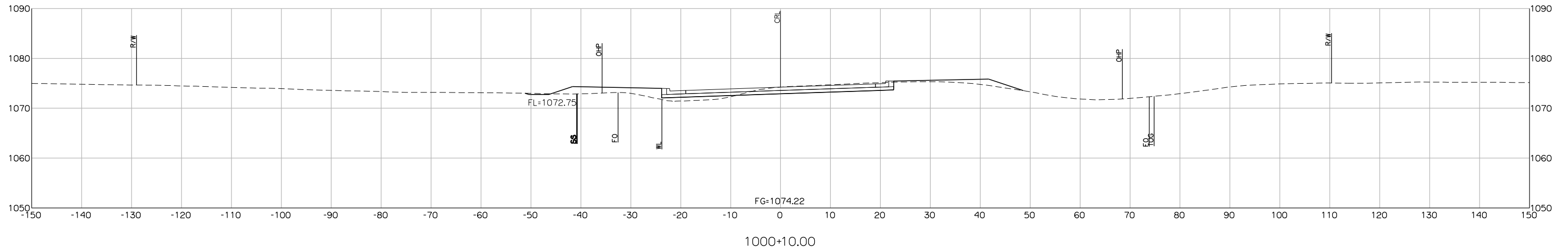

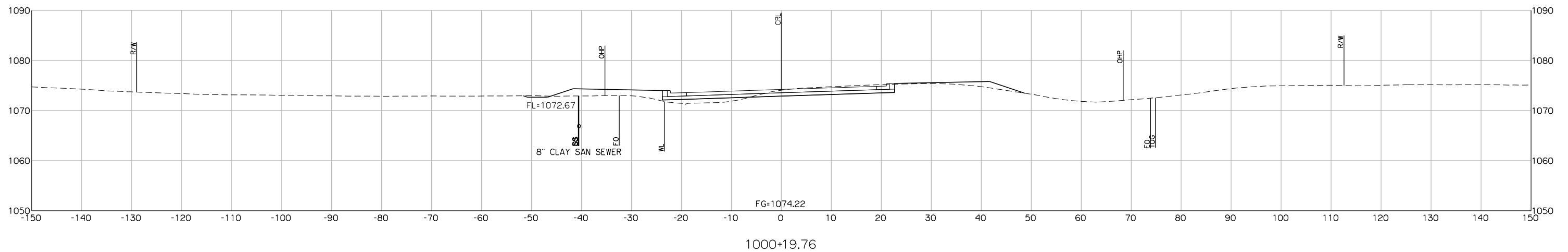
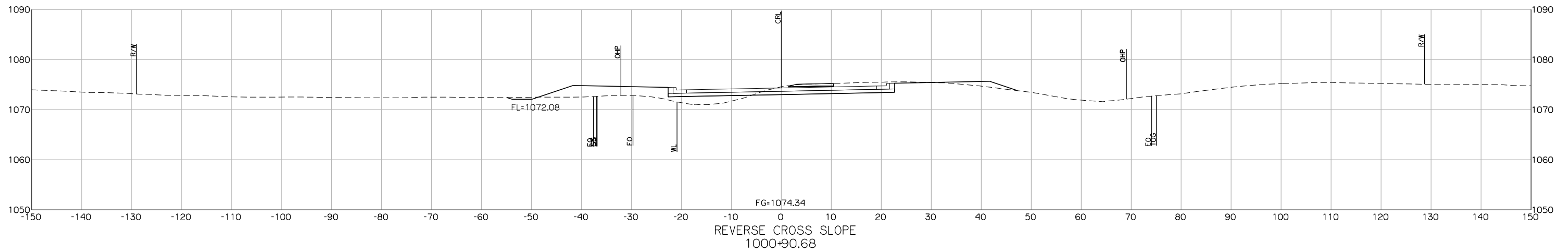
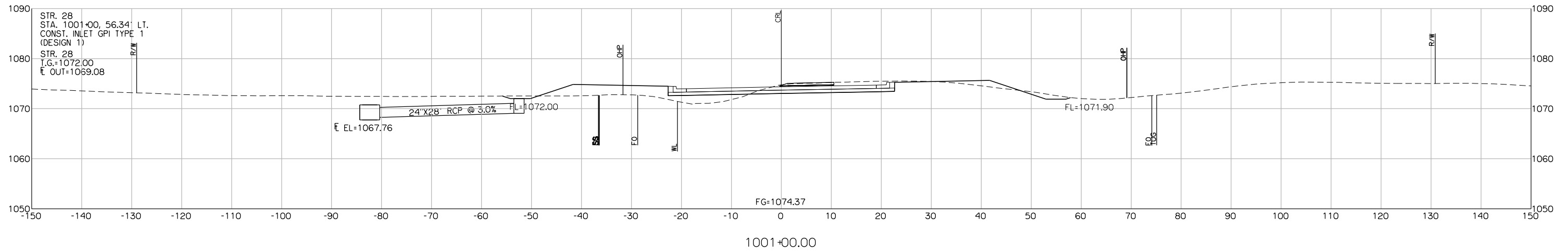

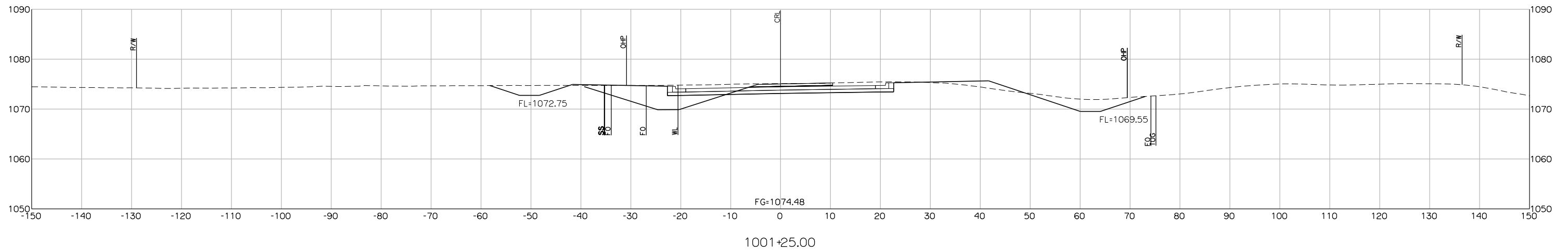
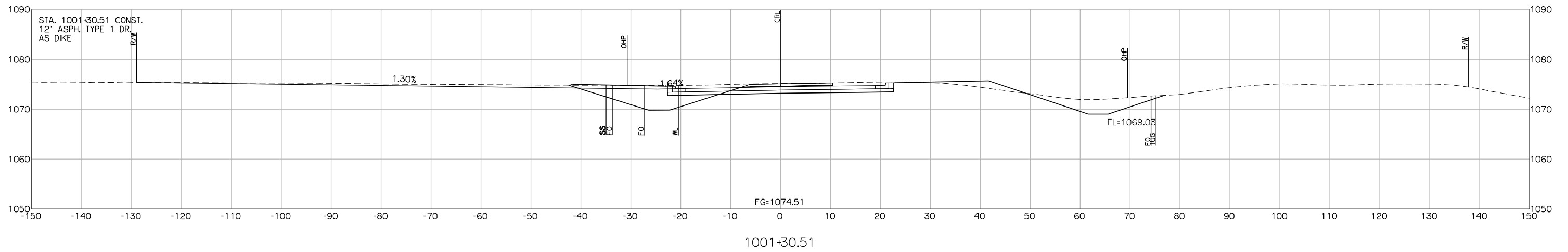
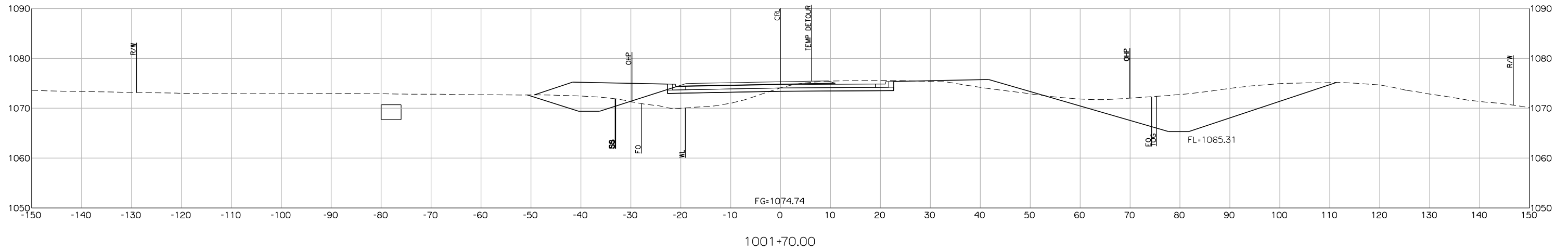

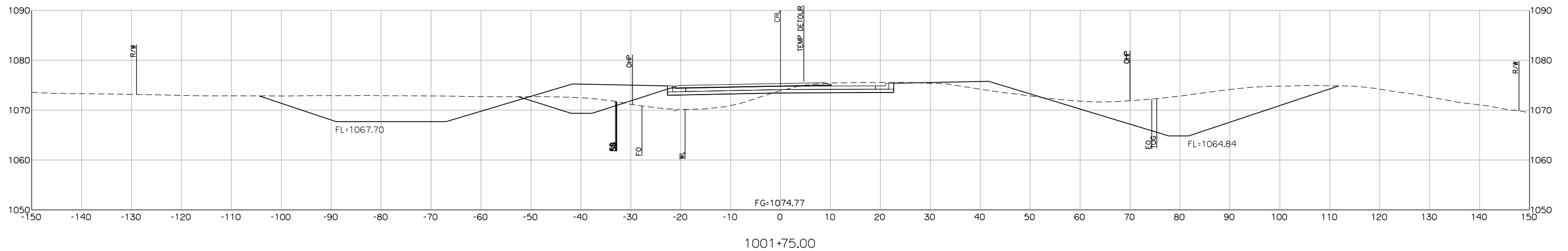
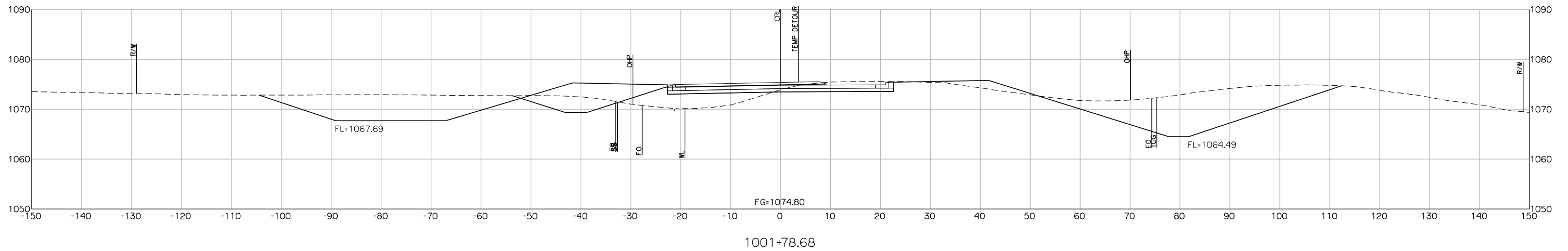
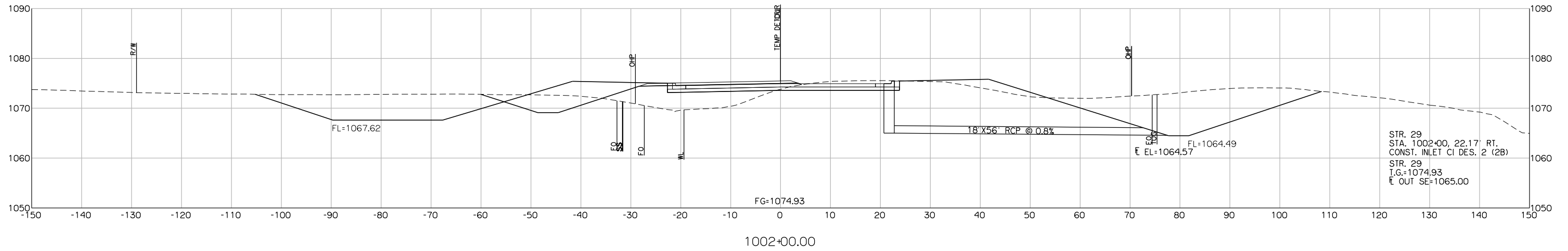

STR. 29
STA. 1002+00, 22.17' RT.
CONST. INLET CI DES. 2 (2B)
STR. 29
I.G.=1074.93
OUT SE=1065.00

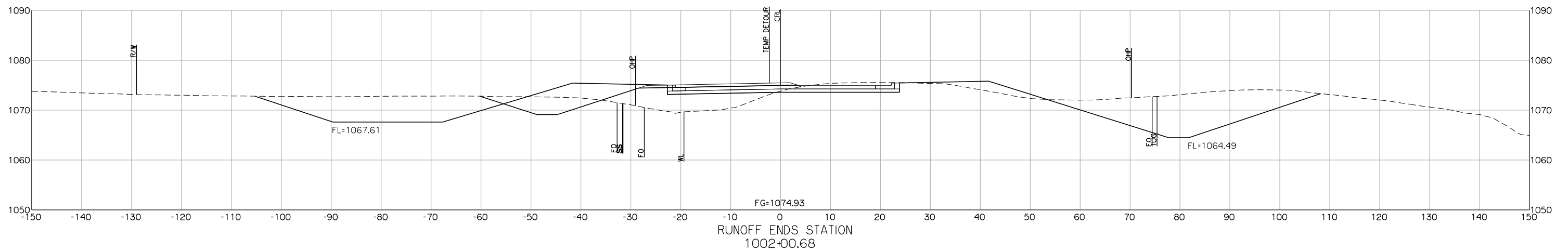
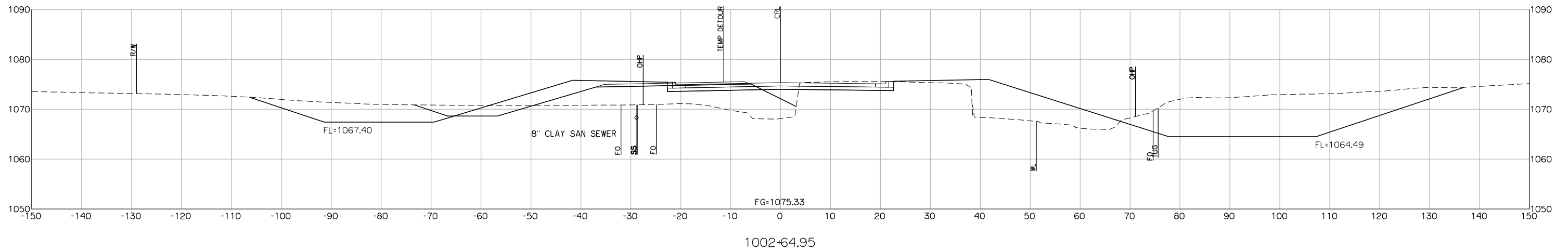
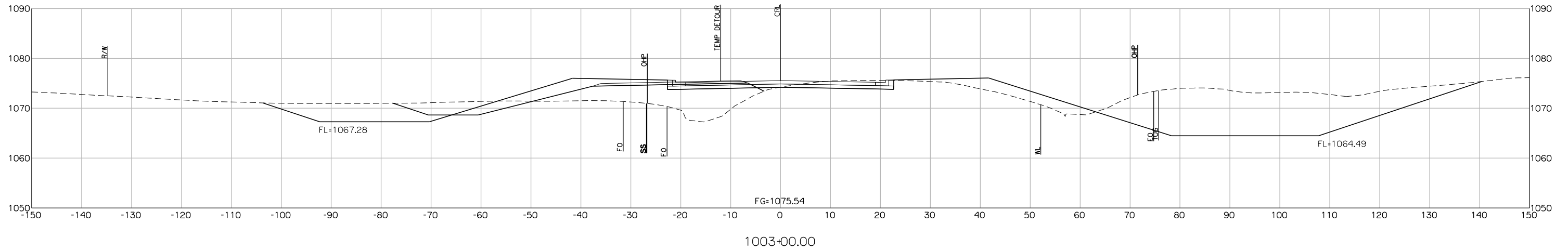

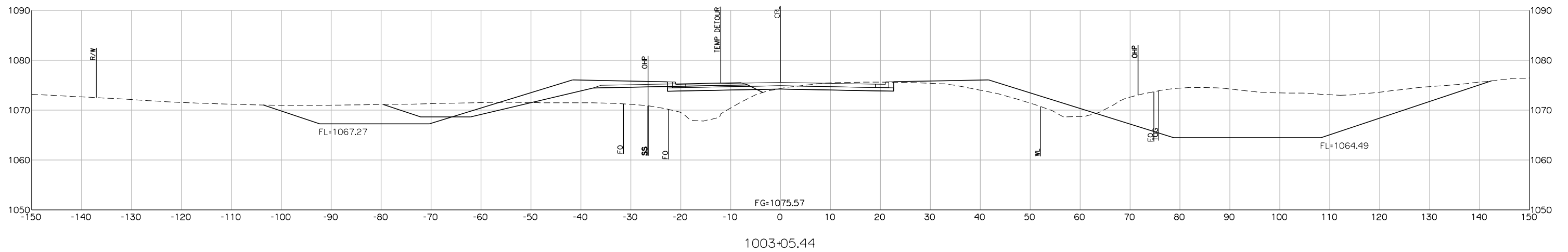
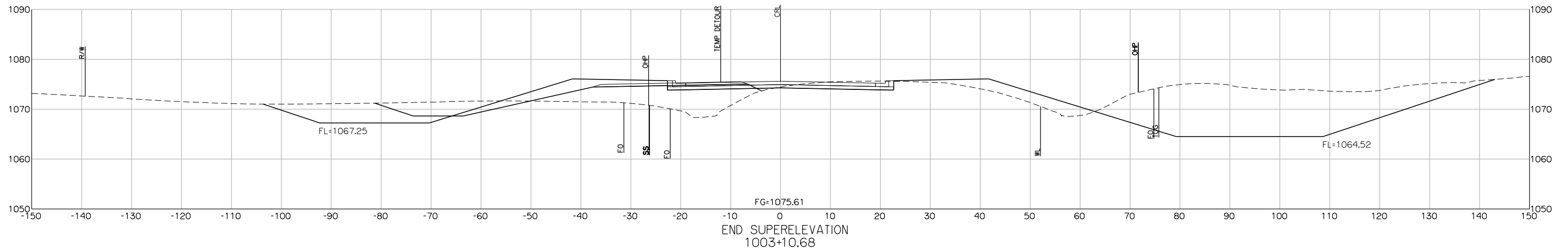
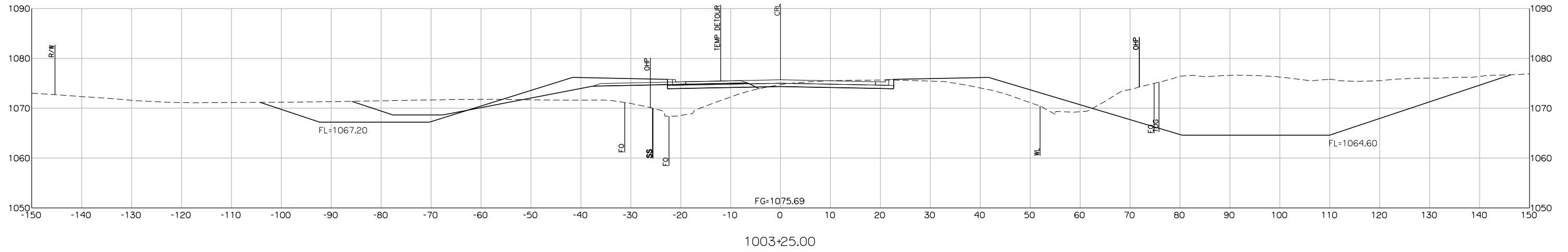

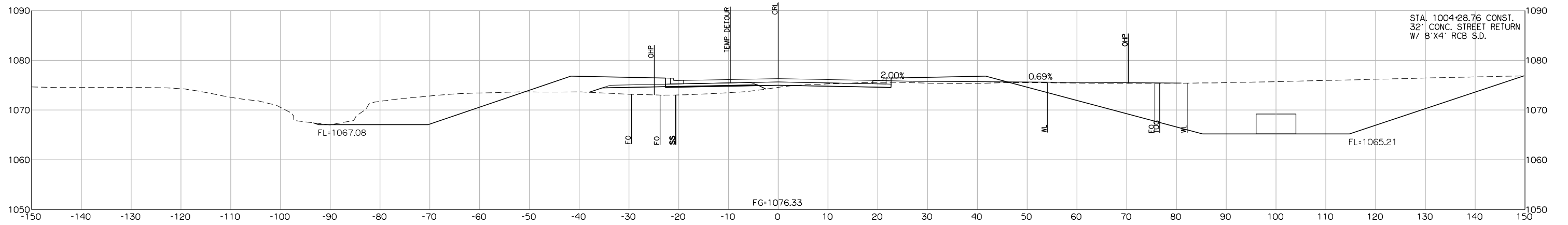

1004+28.76

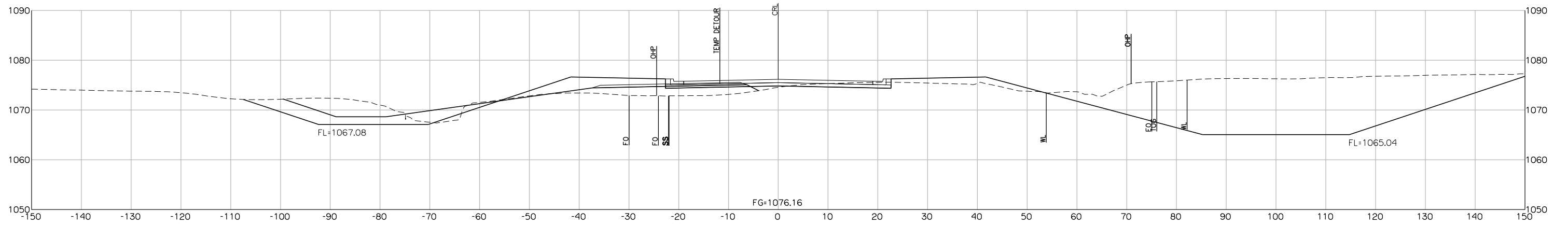

1004+00.00

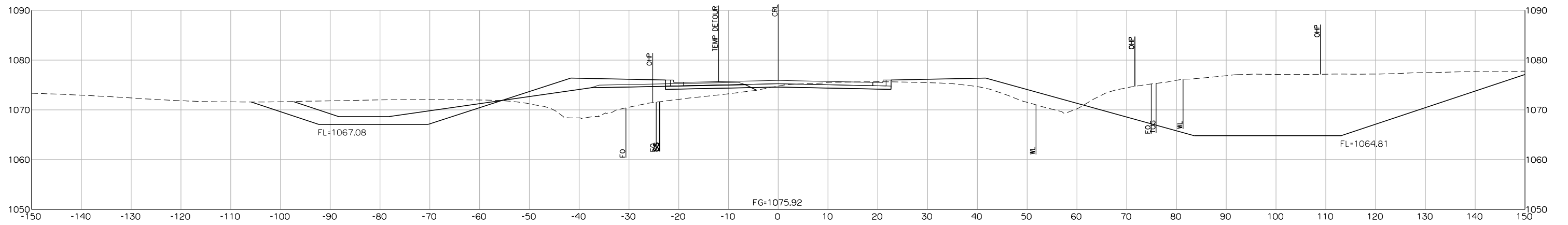

1003+61.29

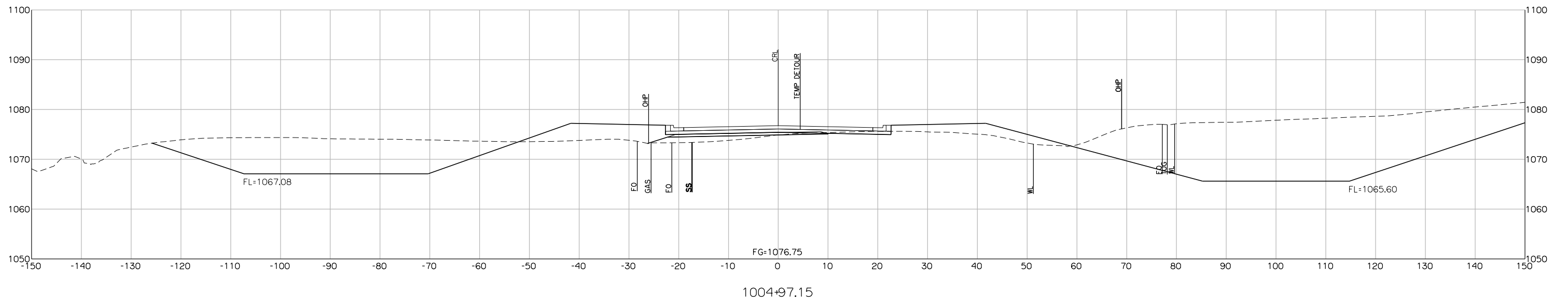
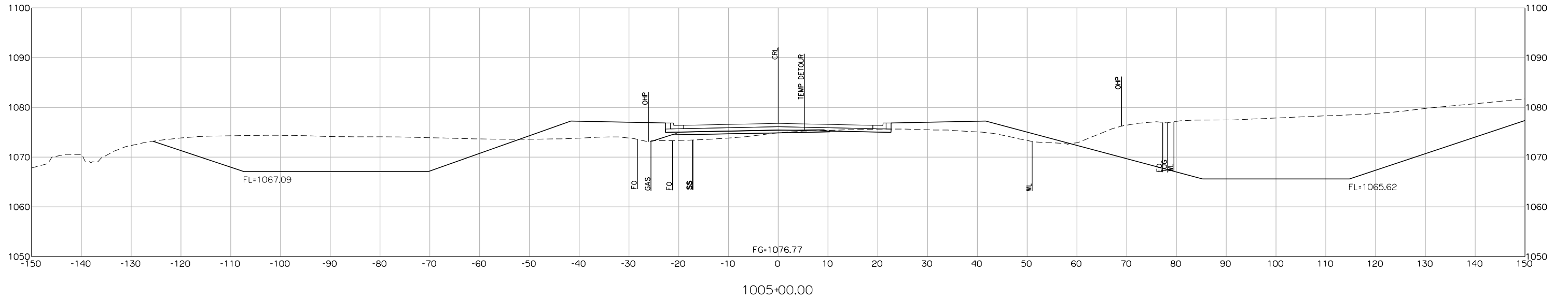

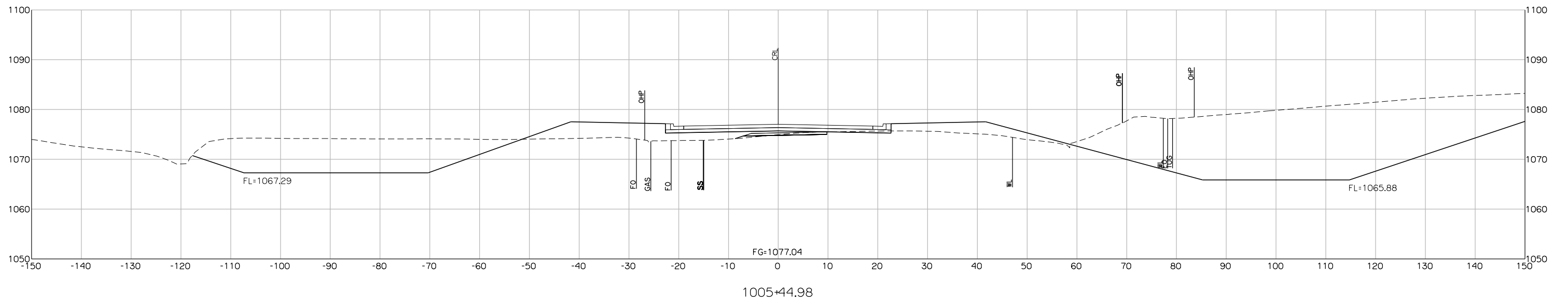
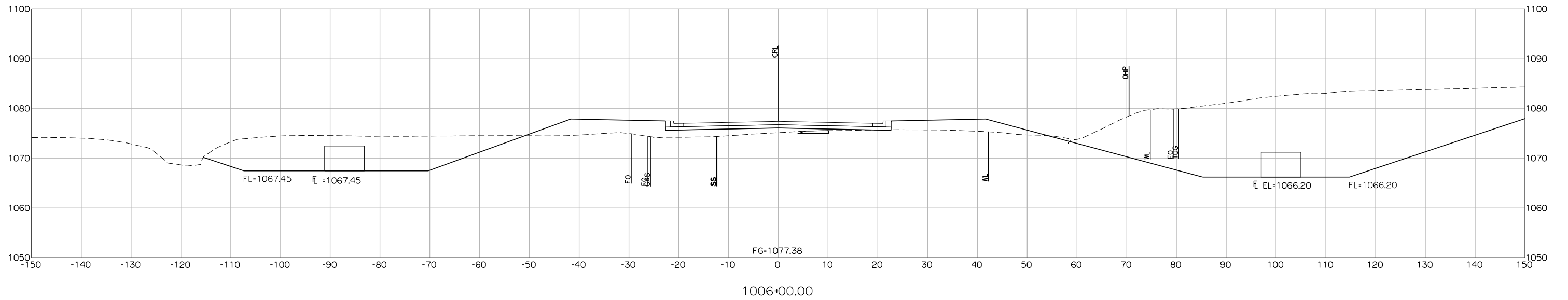

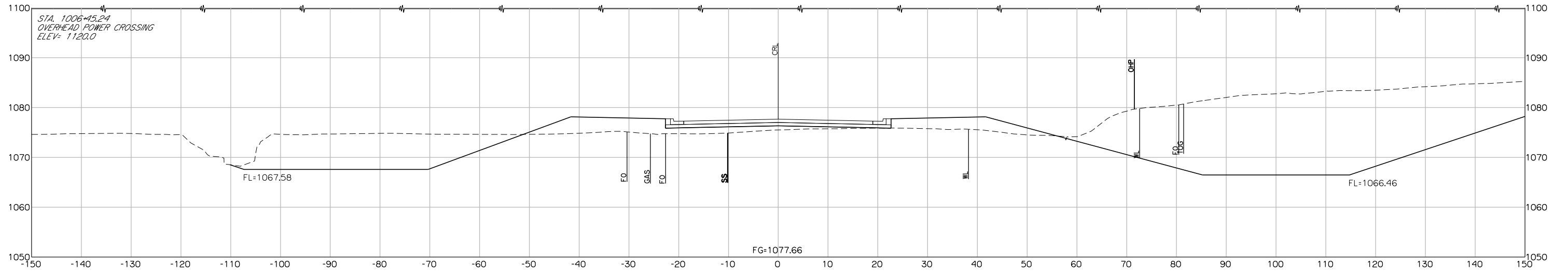

1006+45.24

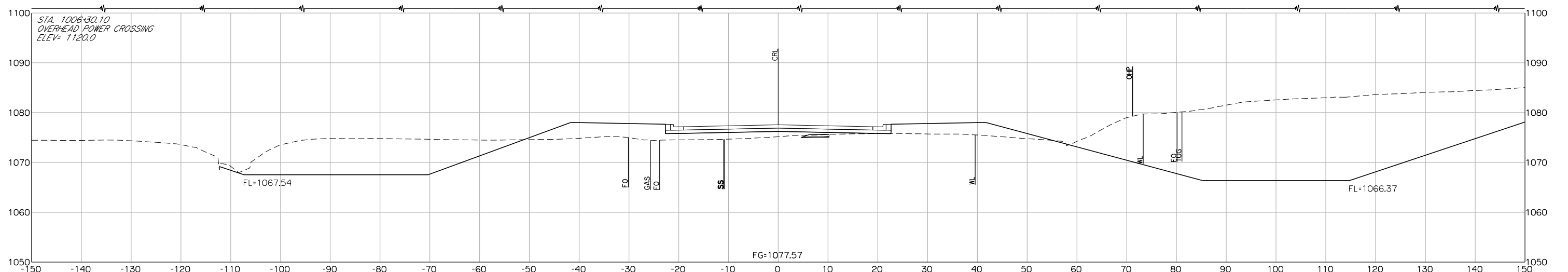

1006+30.10

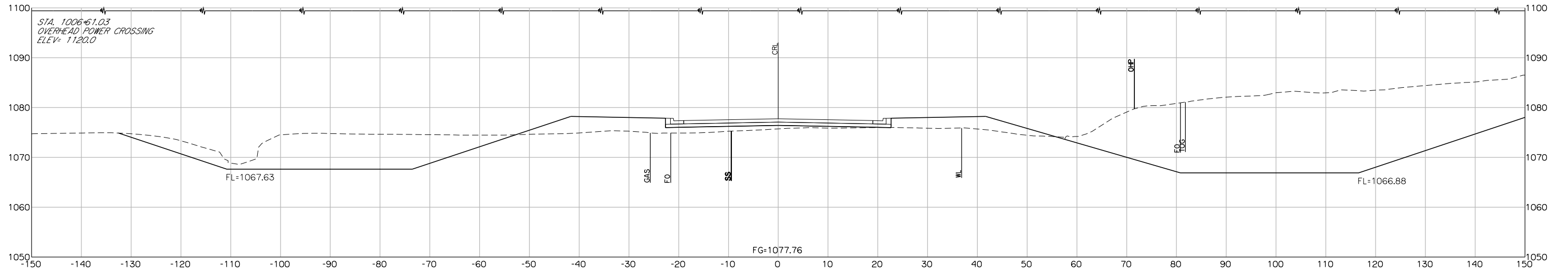

1006+61.03

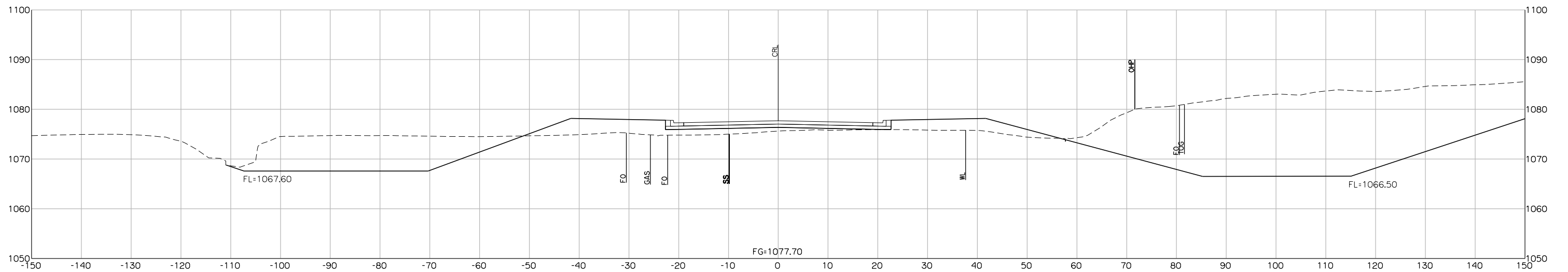

1006+51.96

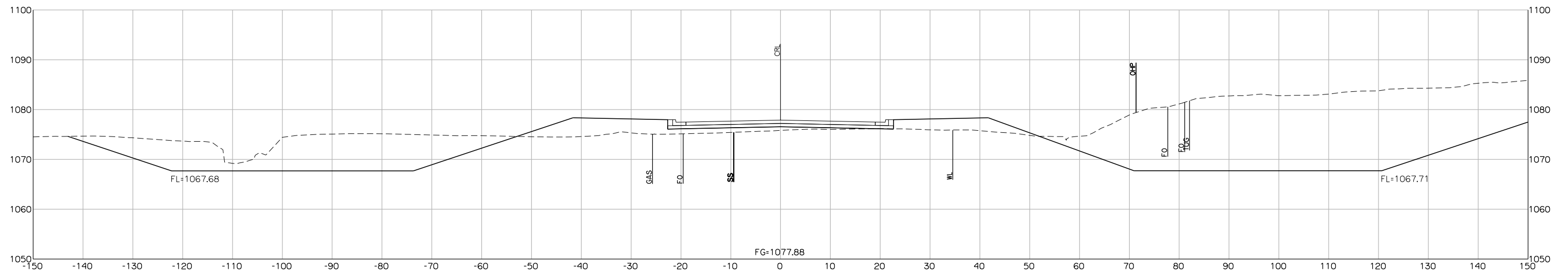

1006+81.15

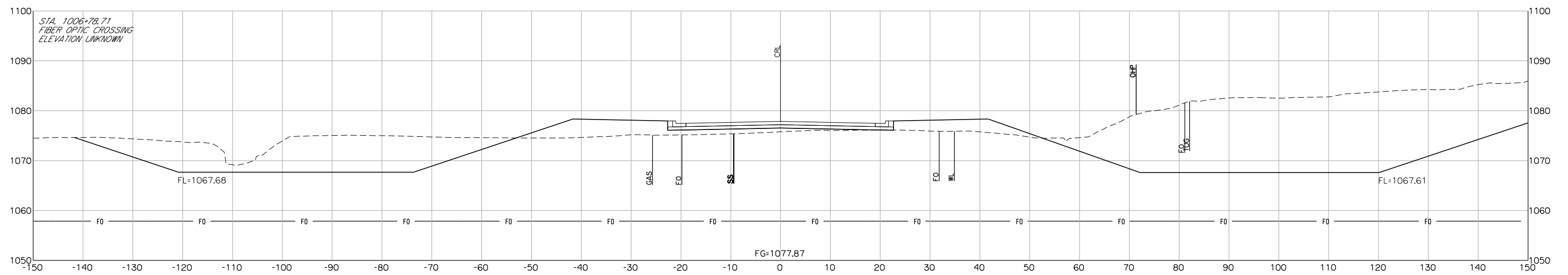

1006+78.71

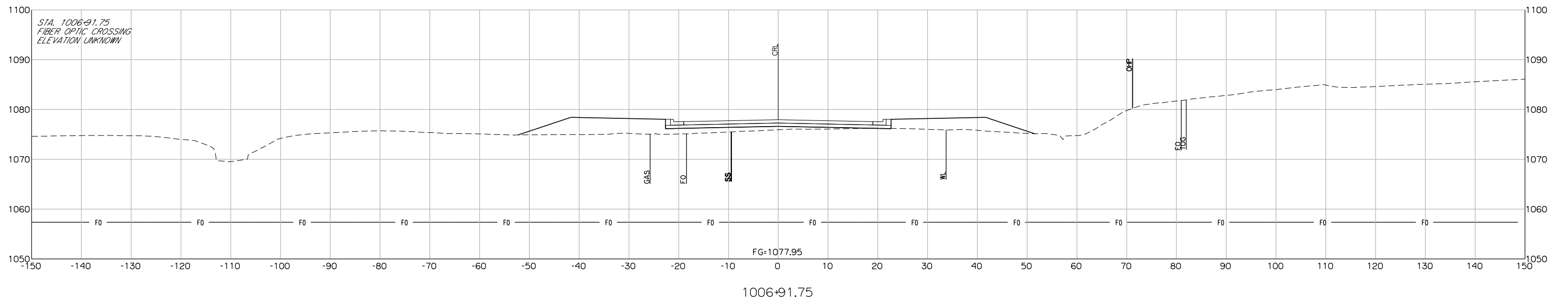
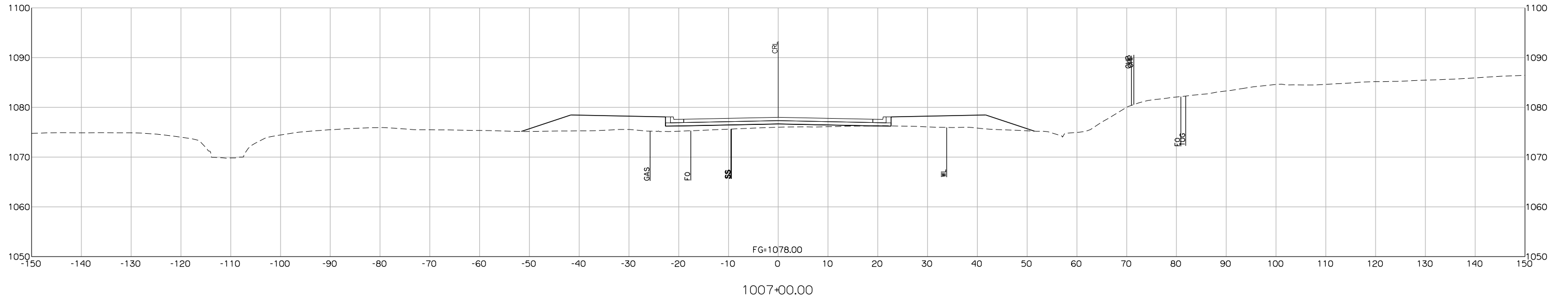

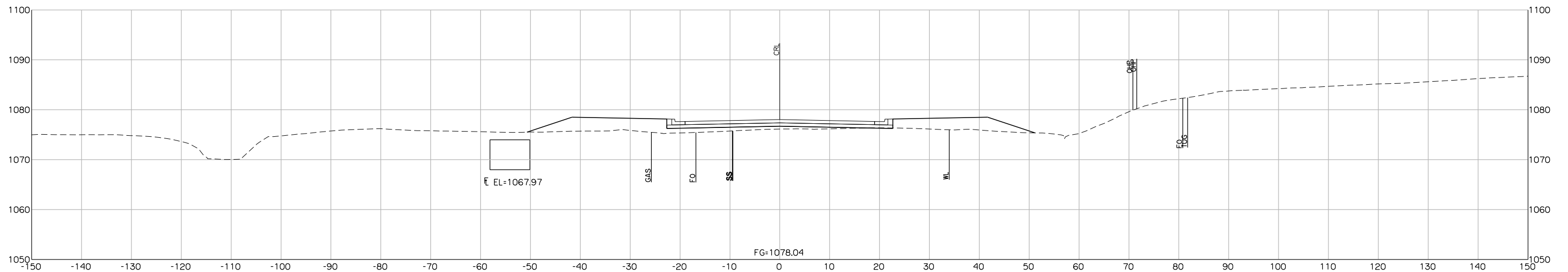
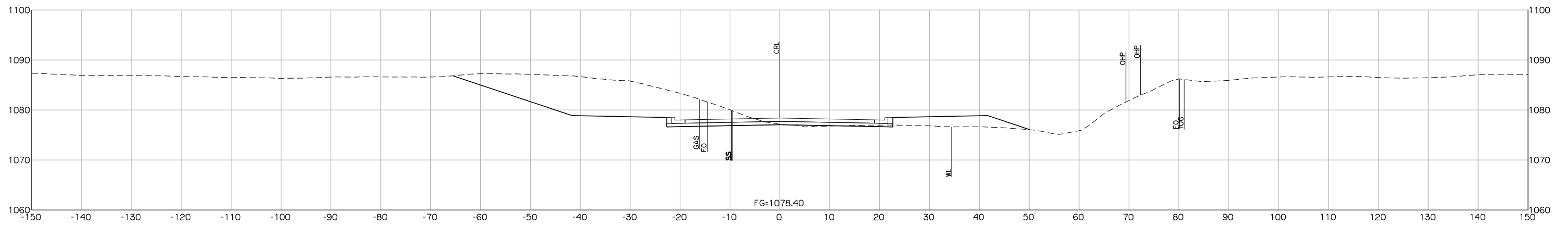
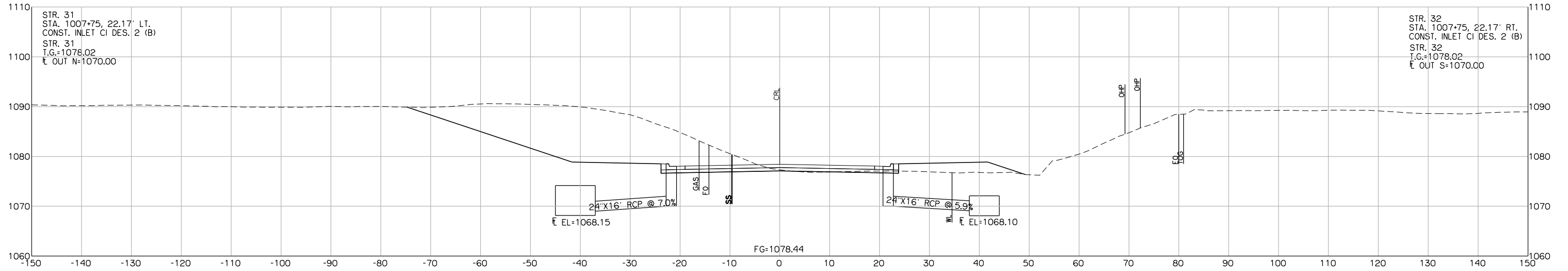

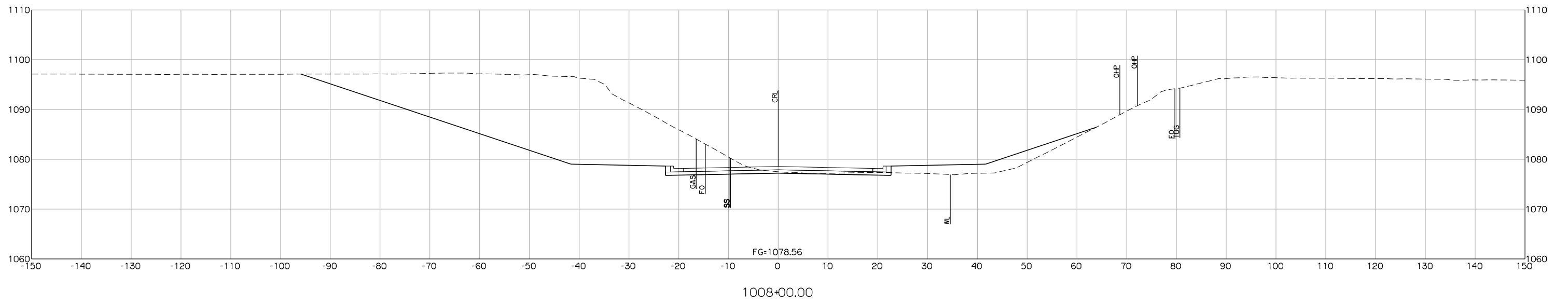
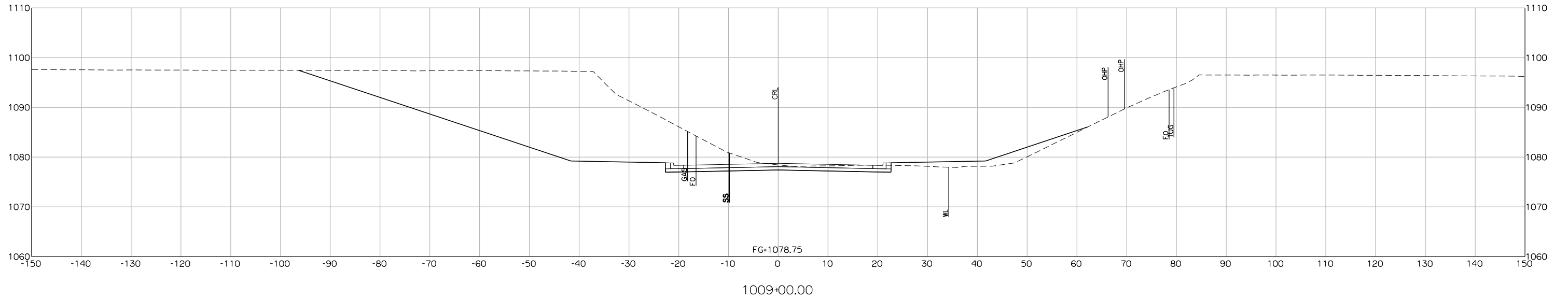

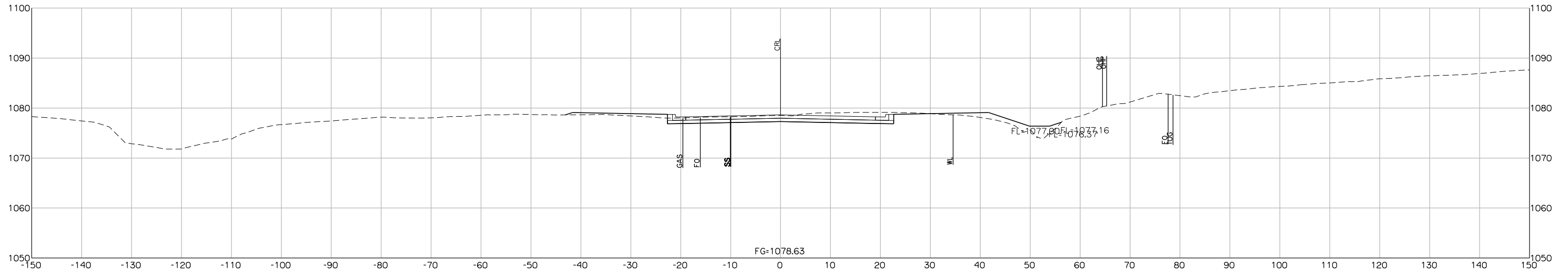

1009+75.00

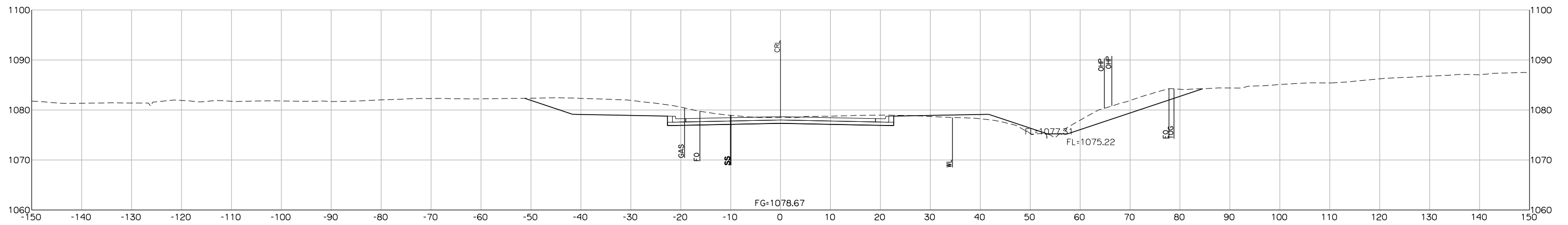

1009+59.56

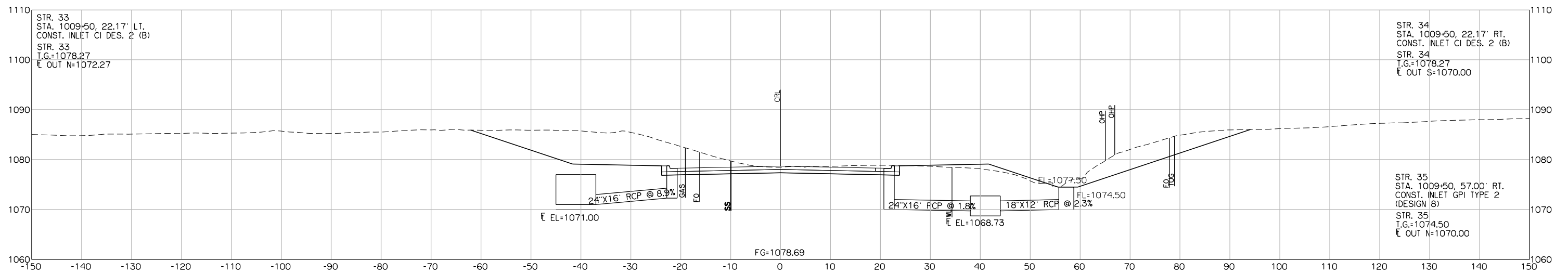

1009+50.00

STR. 33
STA. 1009+50, 22.17' LT.
CONST. INLET CI DES. 2 (B)
STR. 33
I.G.=1078.27
E OUT N=1072.27

STR. 34
STA. 1009+50, 22.17' RT.
CONST. INLET CI DES. 2 (B)
STR. 34
I.G.=1078.27
E OUT S=1070.00

STR. 35
STA. 1009+50, 57.00' RT.
CONST. INLET GPI TYPE 2'
(DESIGN 8)
STR. 35
I.G.=1074.50
E OUT N=1070.00

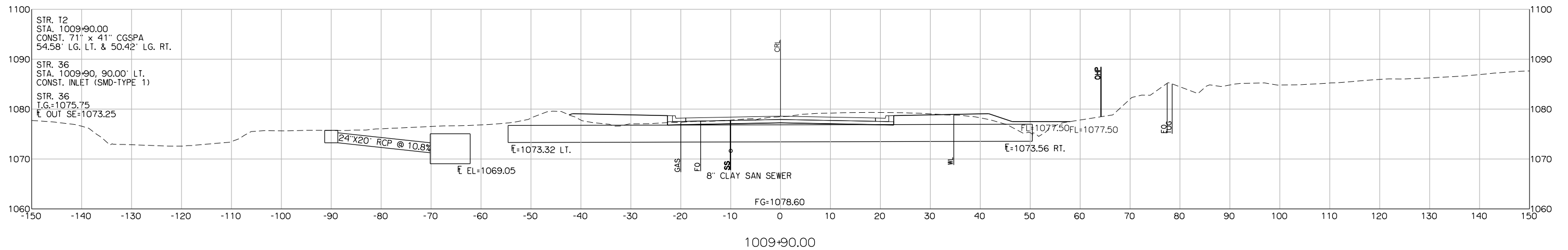
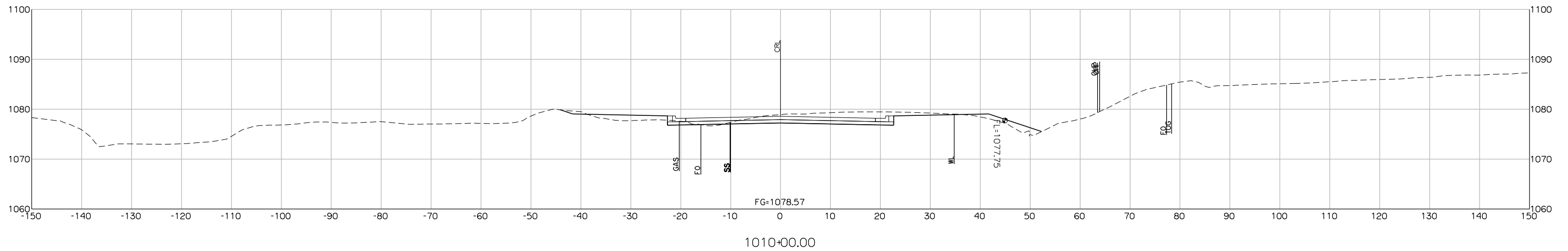
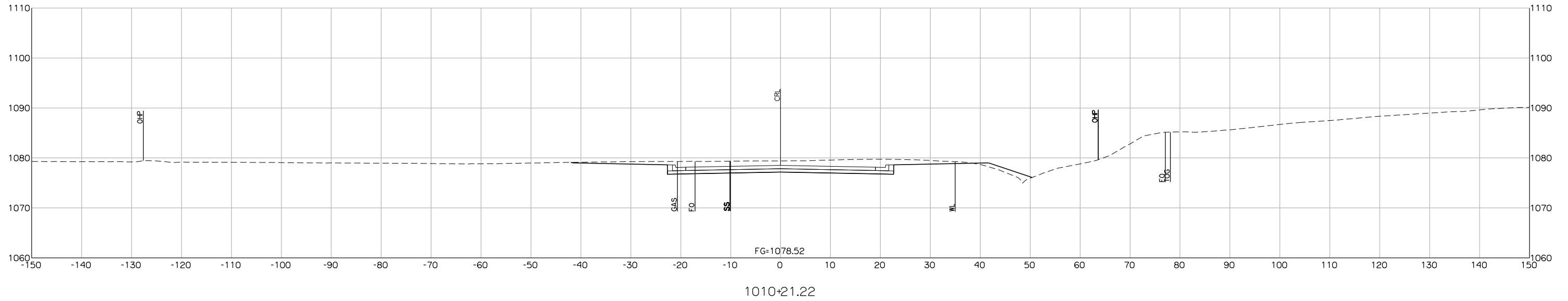

STR. T2
STA. 1009+90.00
CONST. 71" x 41" CGSPA
54.58' LG. LT. & 50.42' LG. RT.

STR. 36
STA. 1009+90, 90.00' LT.
CONST. INLET (SMD-TYPE 1)

STR. 36
I.G.=1075.75
E OUT SE=1073.25

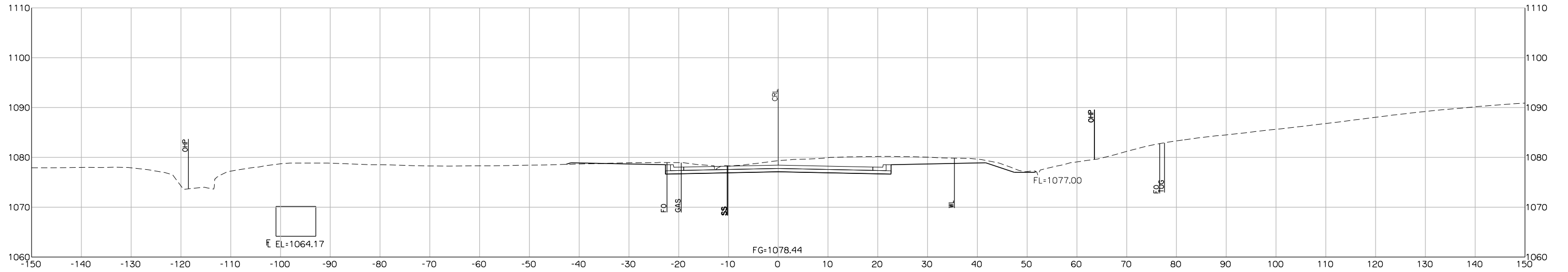

1010+60.00

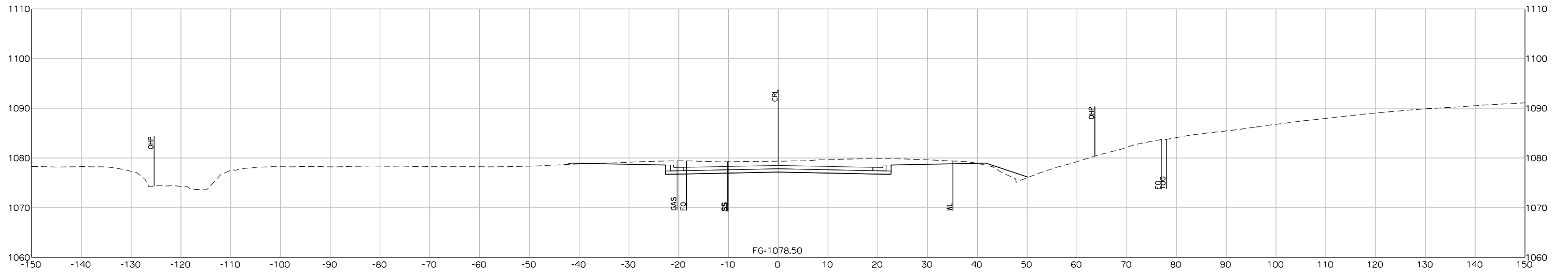

1010+30.80

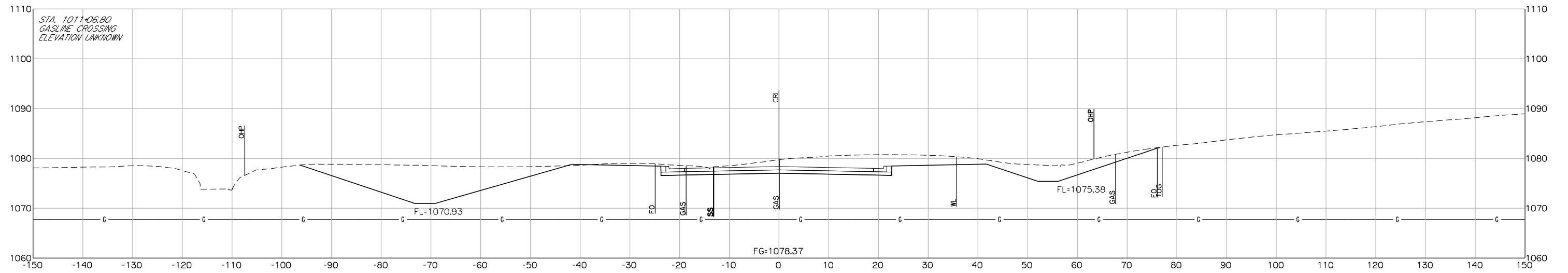

1011+06.80

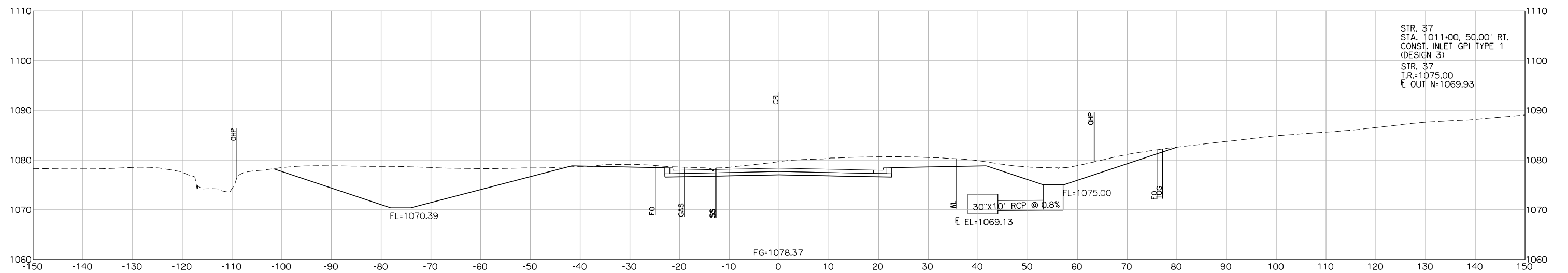

1011+00.00

STR. 37
STA. 1011+00, 50.00' RT.
CONST. INLET GPI TYPE 1
(DESIGN 3)
STR. 37
I.R.=1075.00
E OUT N=1069.93

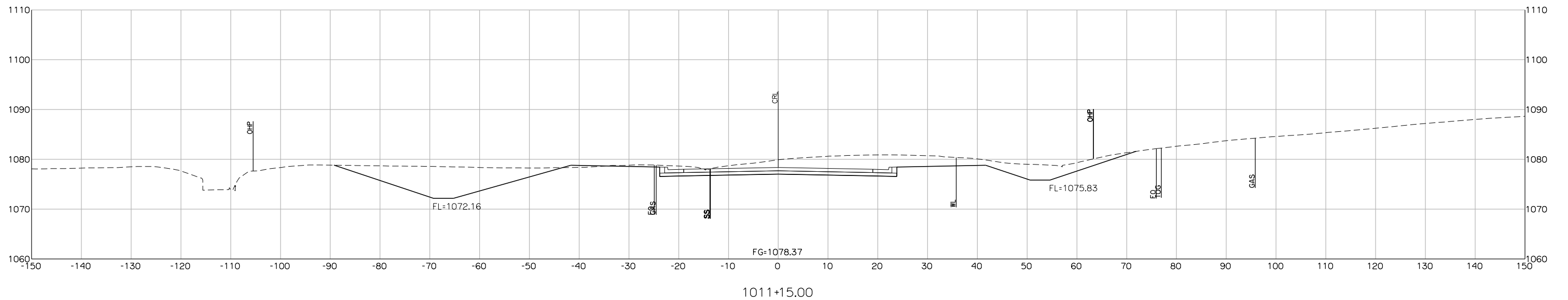
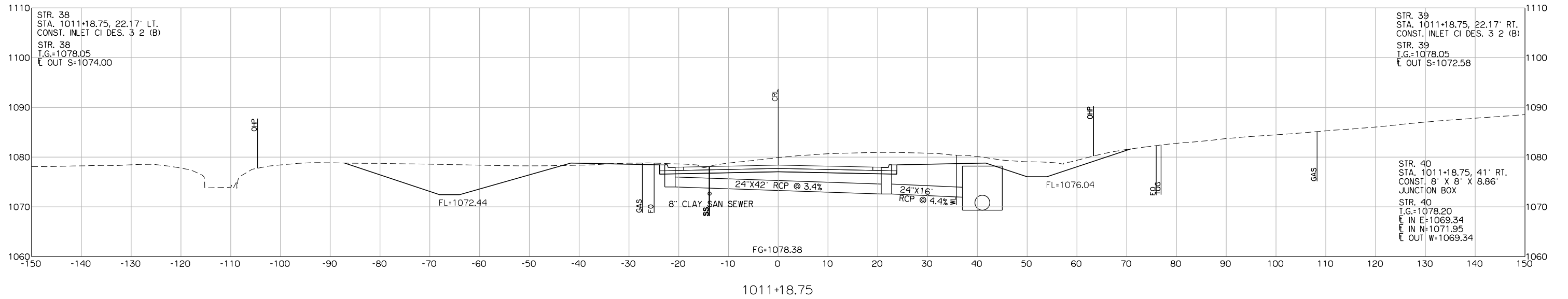
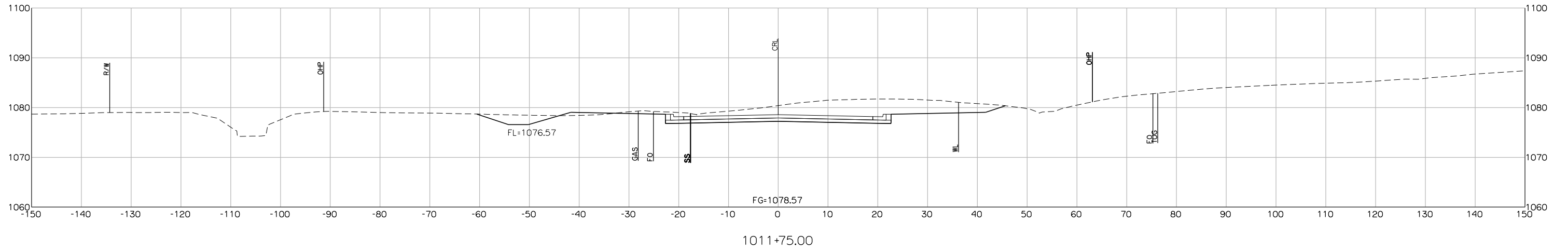

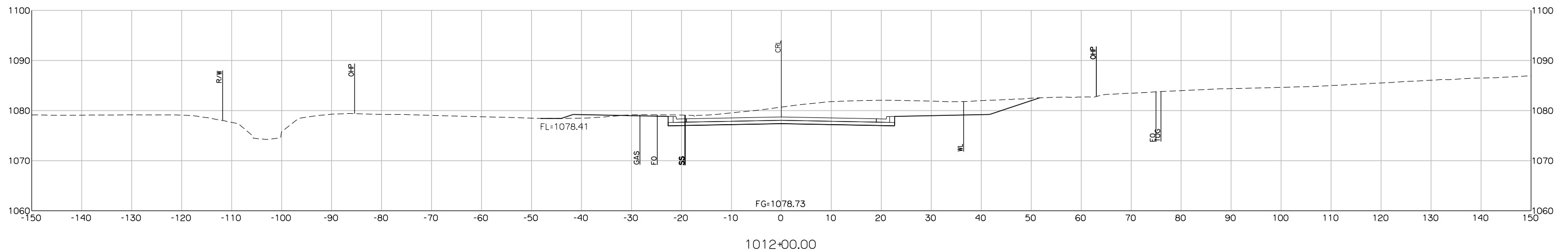
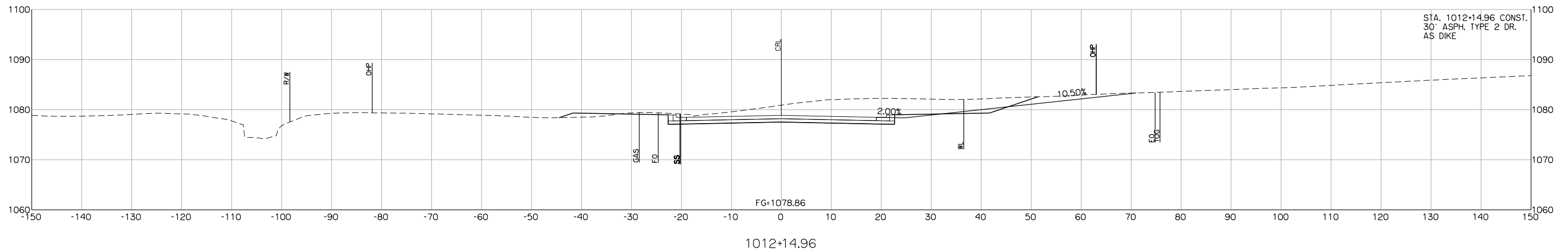
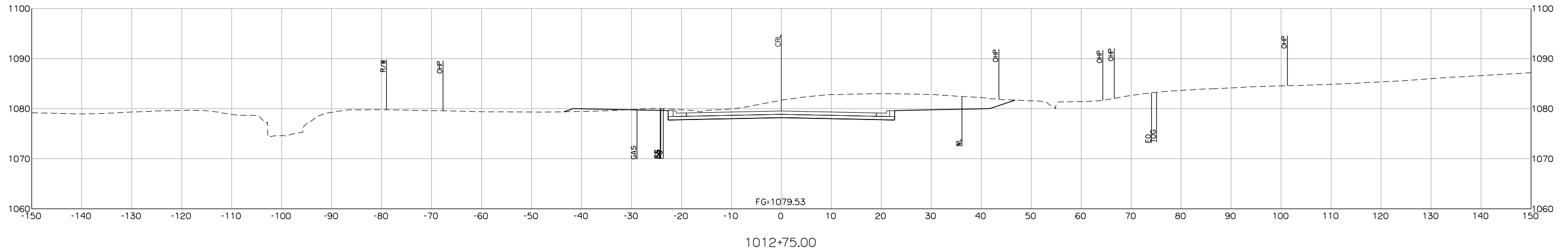

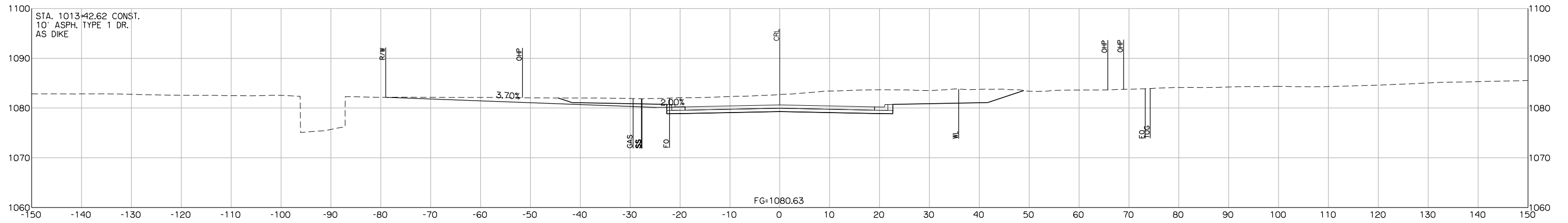

1013+42.62

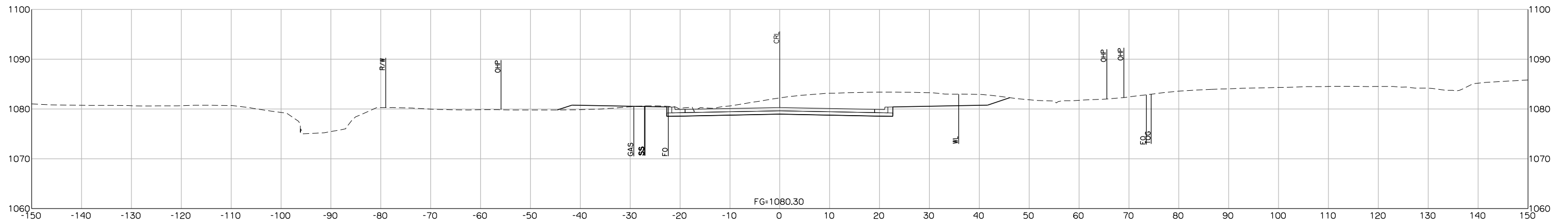

1013+25.00

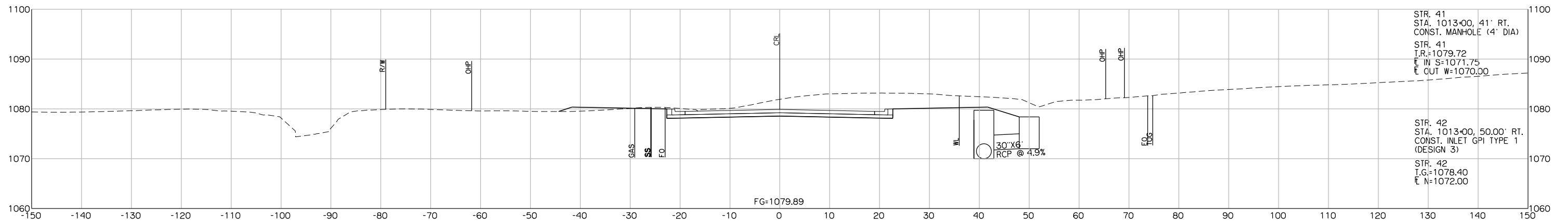

1013+00.00

STR. 41
 STA. 1013+00, 41' RT.
 CONST. MANHOLE (4' DIA)
 STR. 41
 I.R.=1079.72
 E IN S=1071.75
 E OUT W=1070.00

STR. 42
 STA. 1013+00, 50.00' RT.
 CONST. INLET GPI TYPE 1
 (DESIGN 3)
 STR. 42
 I.G.=1078.40
 E N=1072.00

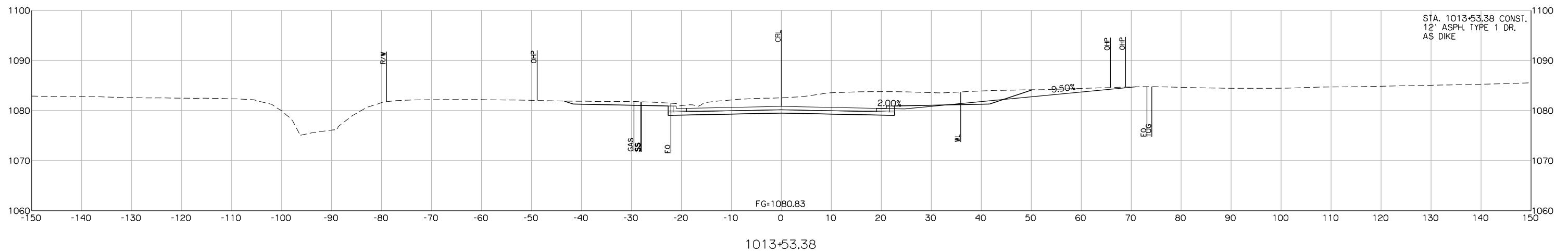
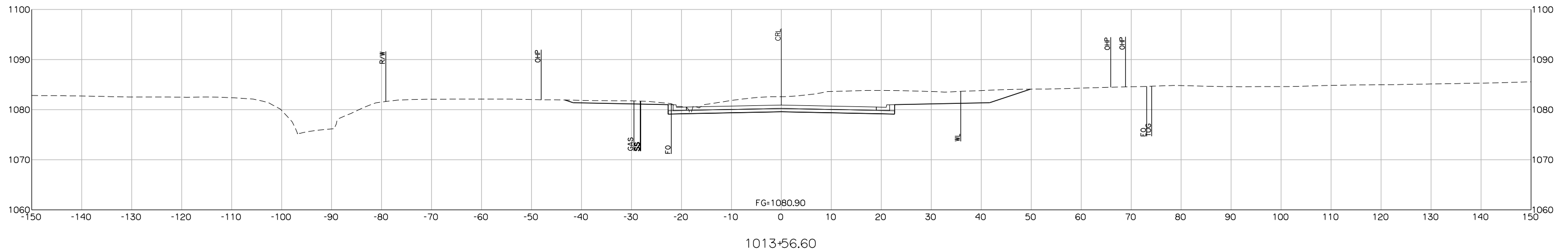
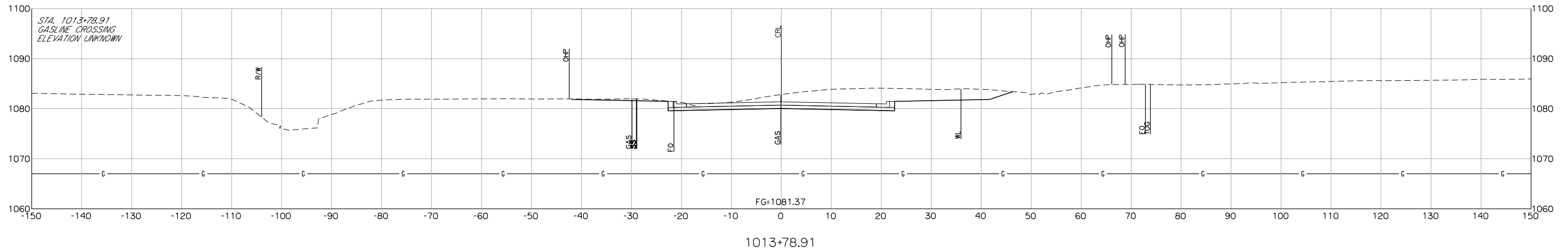

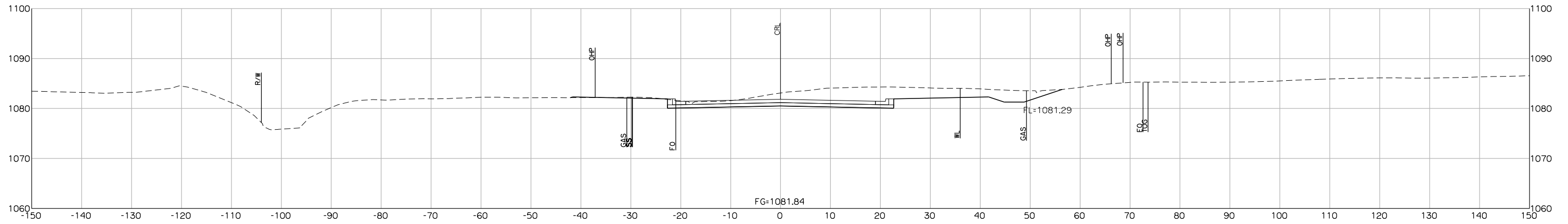

1014+00.00

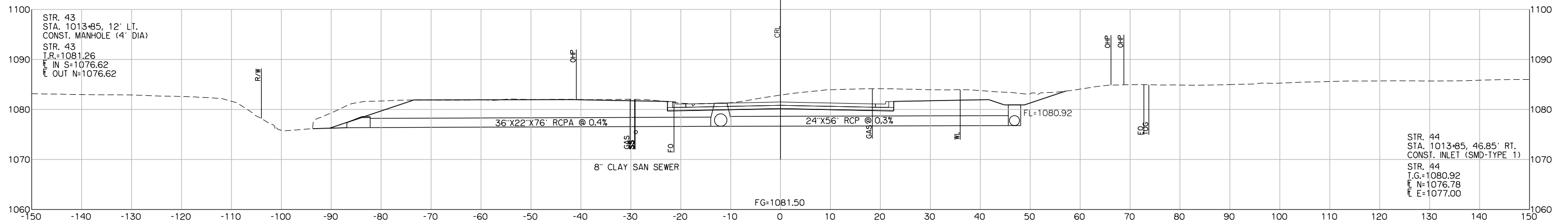

1013+85.00

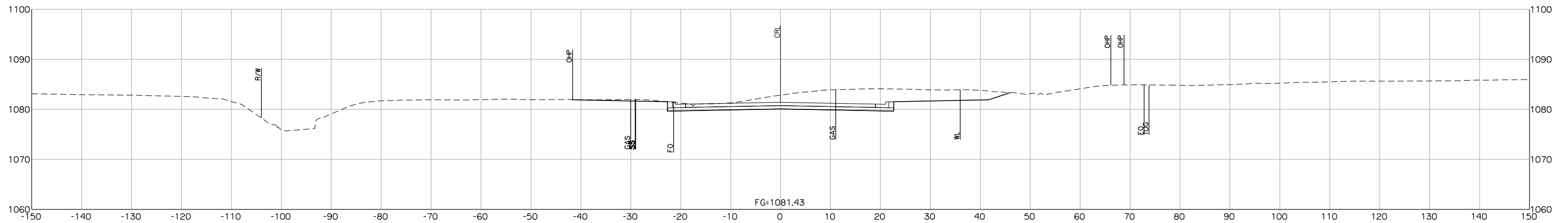

1013+82.00

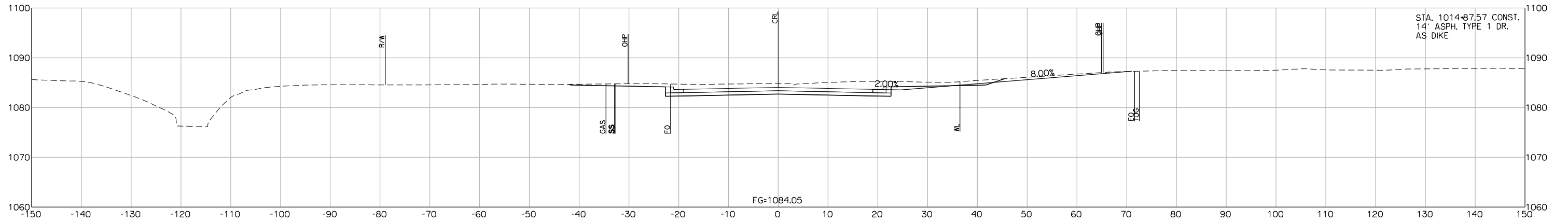

1014+87.57

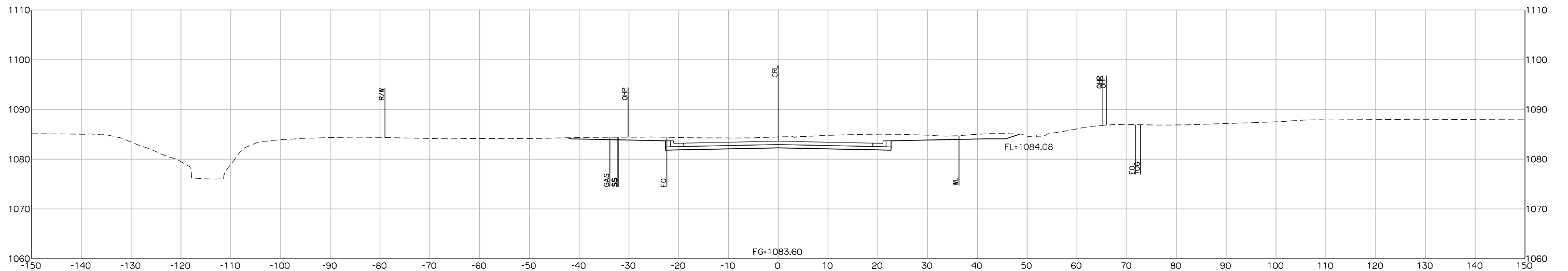

1014+70.00

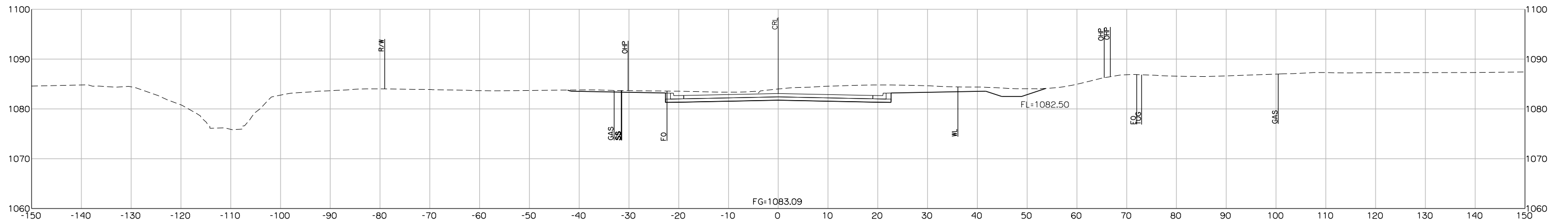

1014+50.00

PROPOSED
R/W
12/17/2021

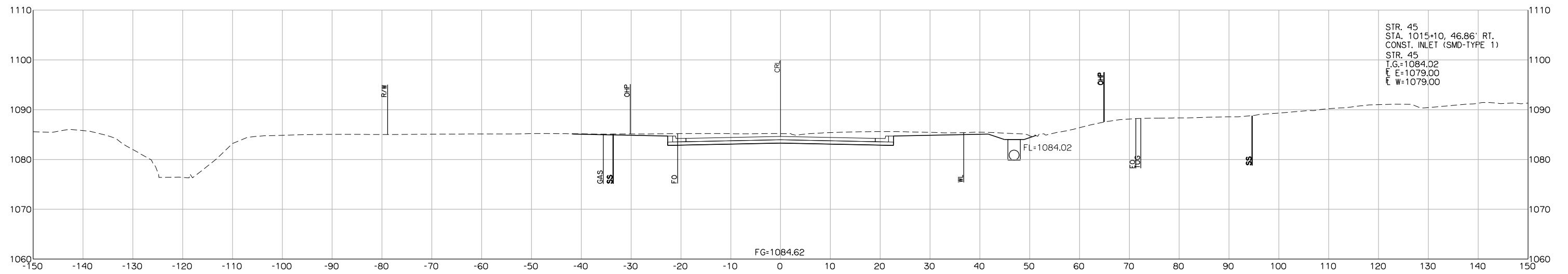

1015+00.00

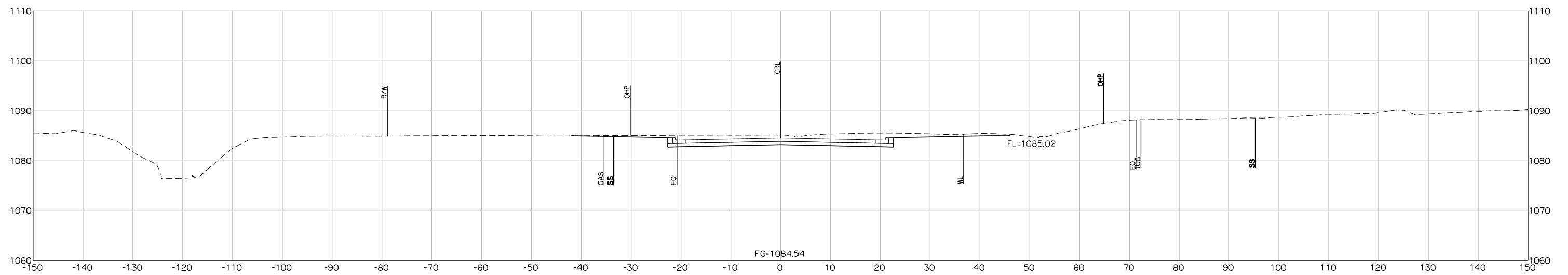

1015+07.00

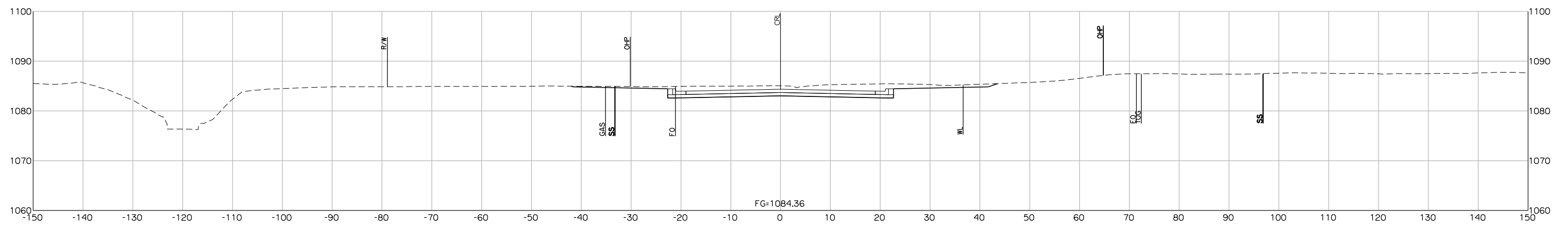

1015+00.00

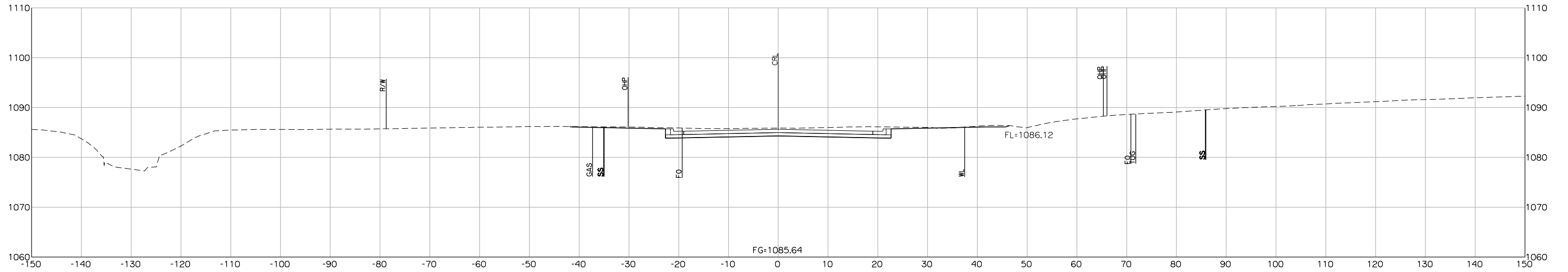

1015+50.00

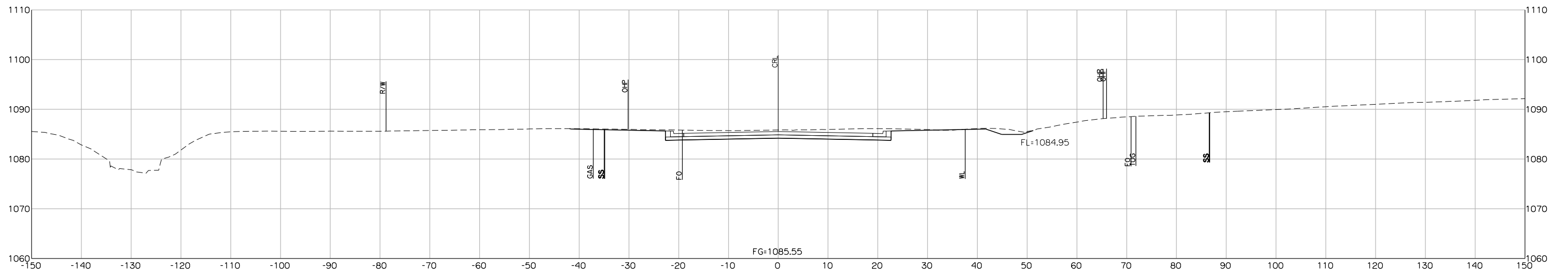

1015+46.50

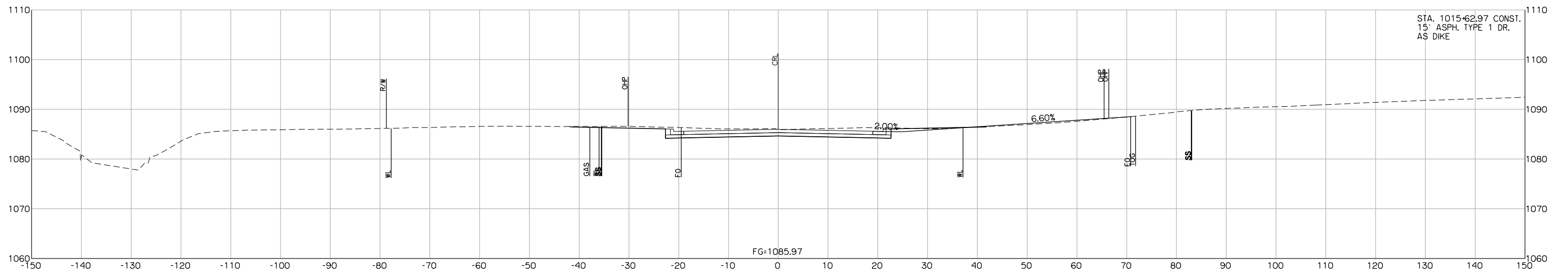
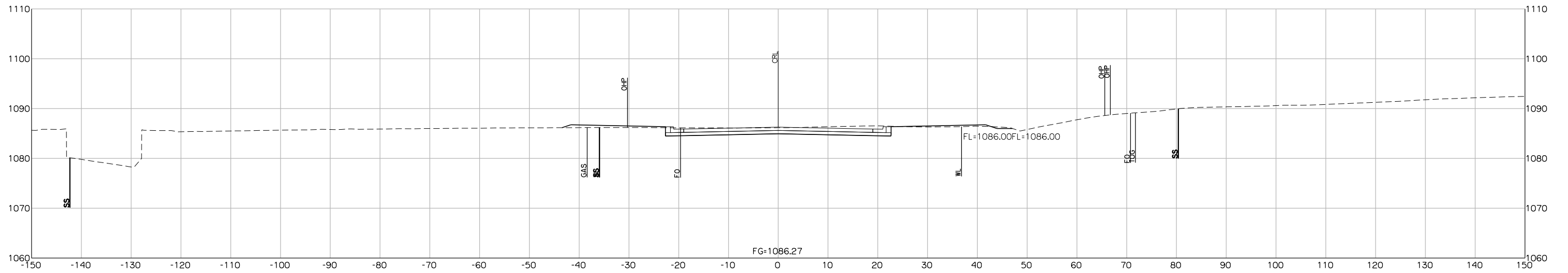

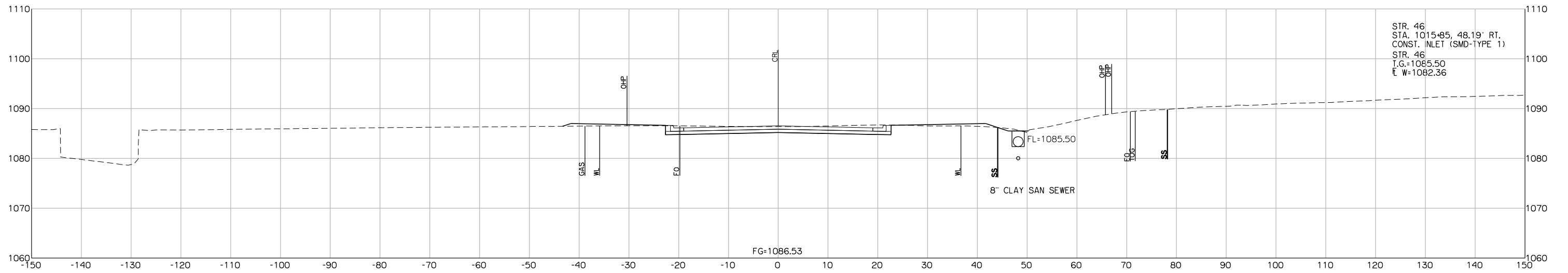

1015+85.00

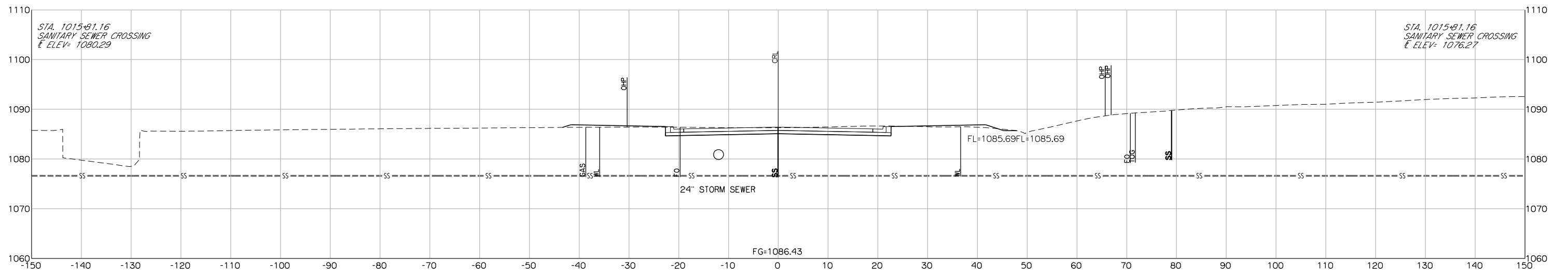

1015+81.16

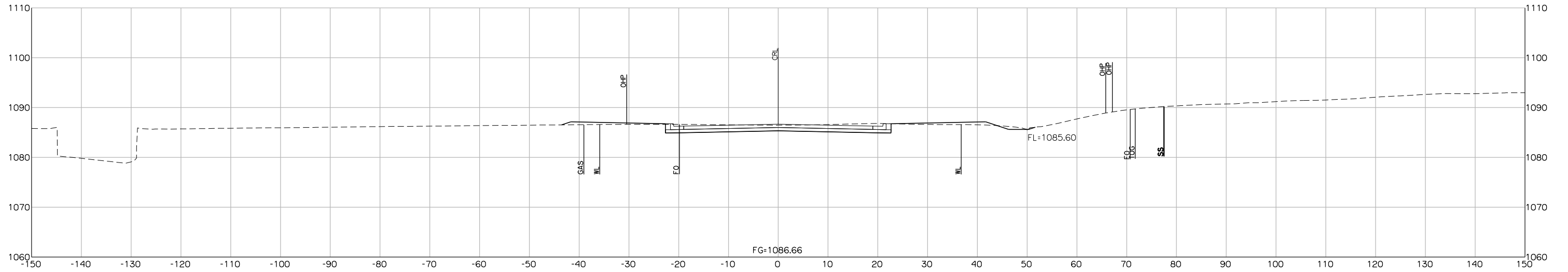

1015+90.27

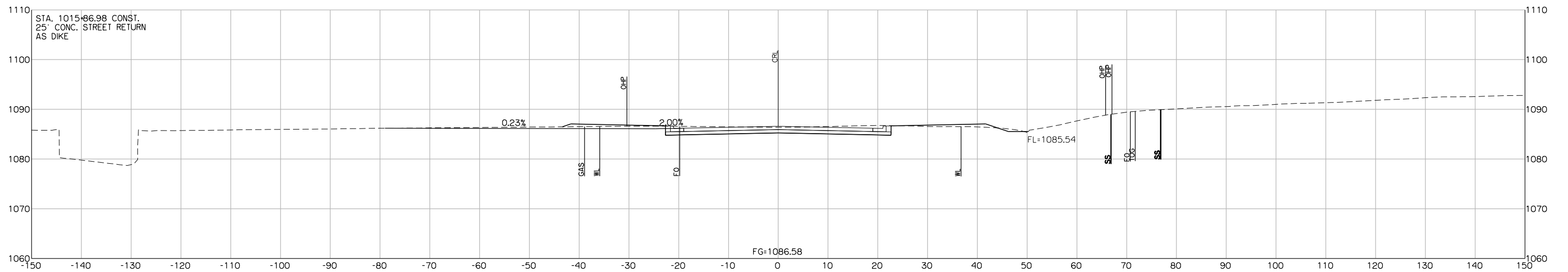

1015+86.98

STA. 1015+86.98 CONST.
25' CONC. STREET RETURN
AS DIKE

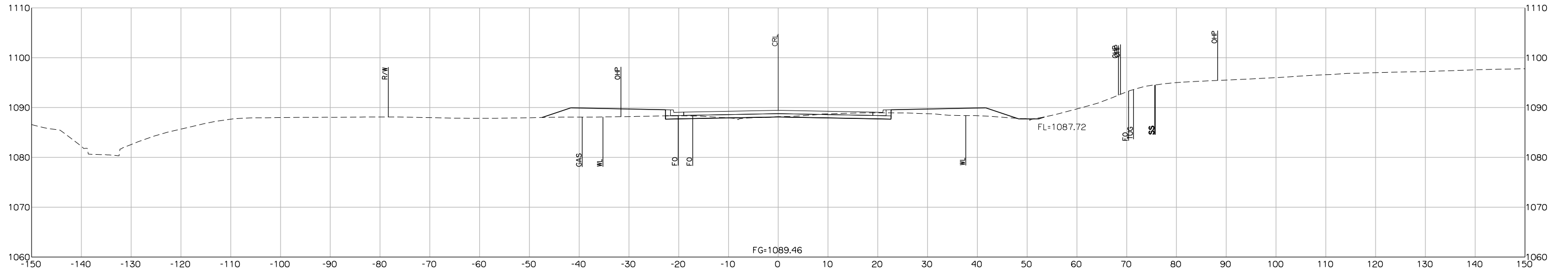

1017+00.00

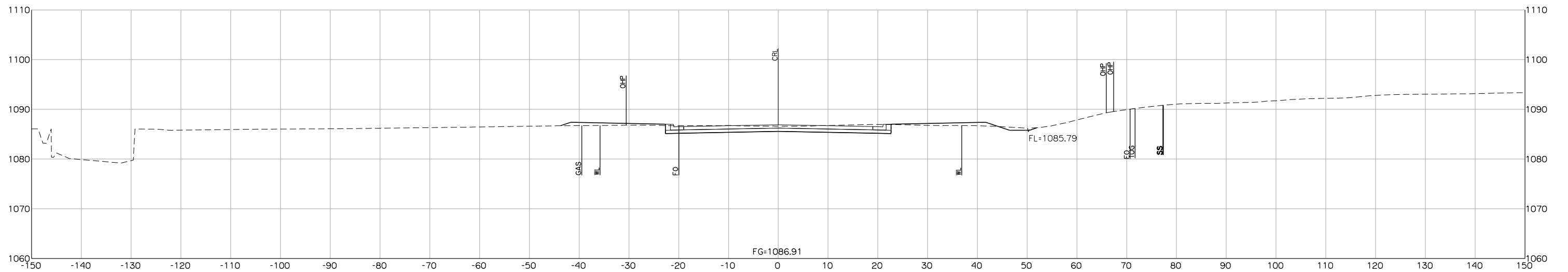

1016+00.00

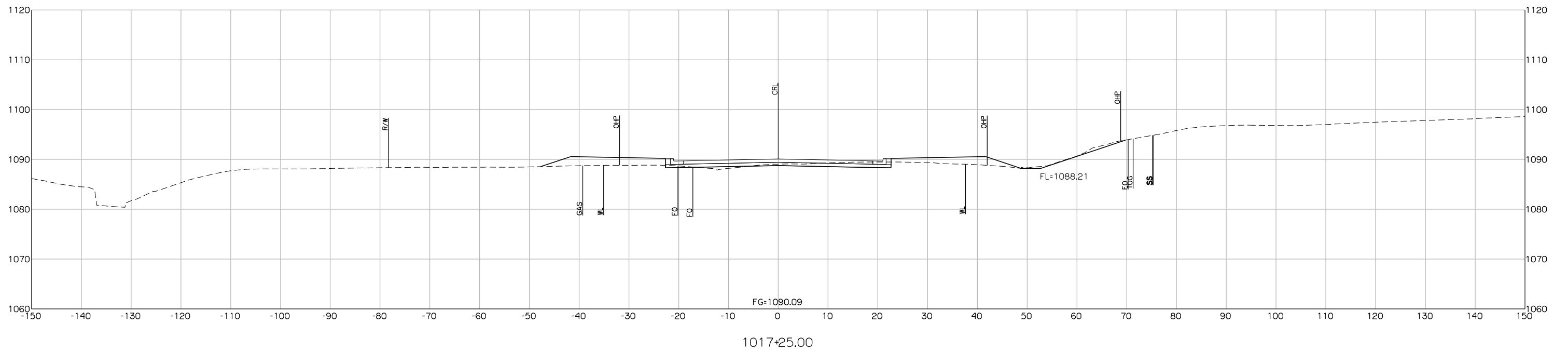
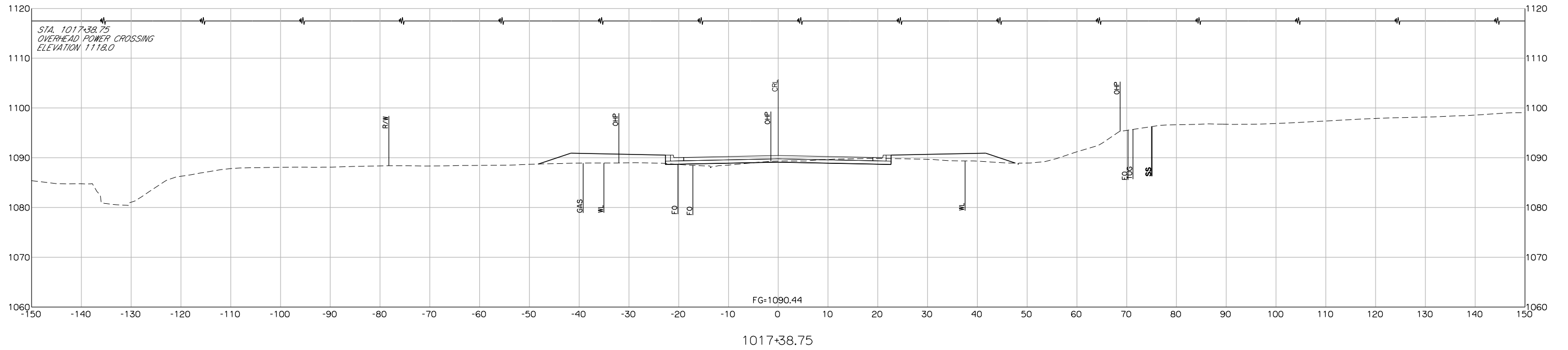

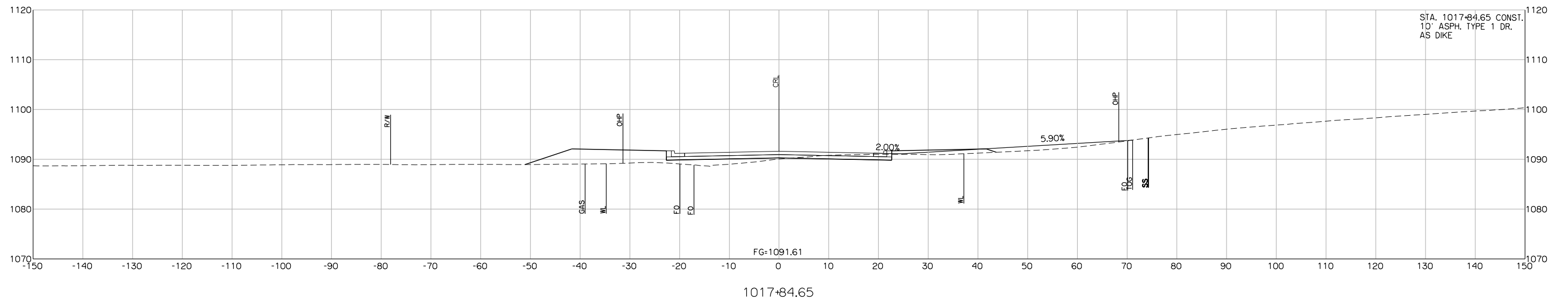
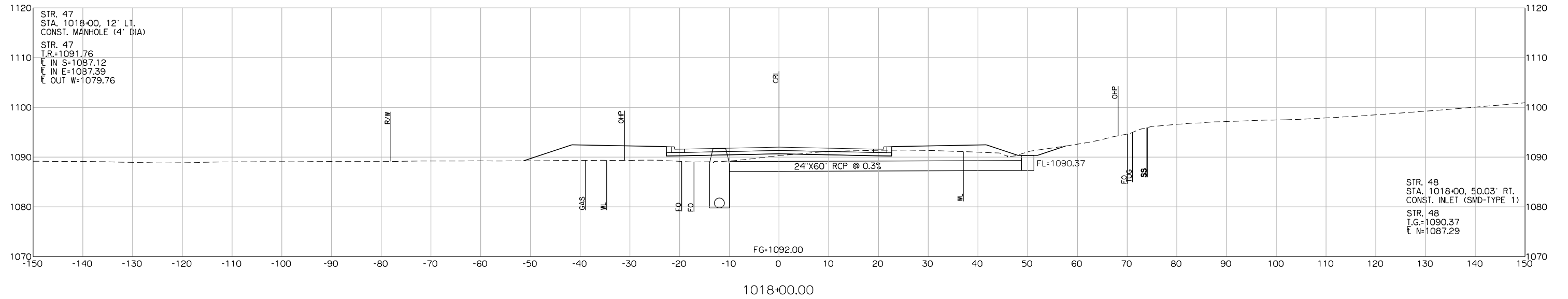

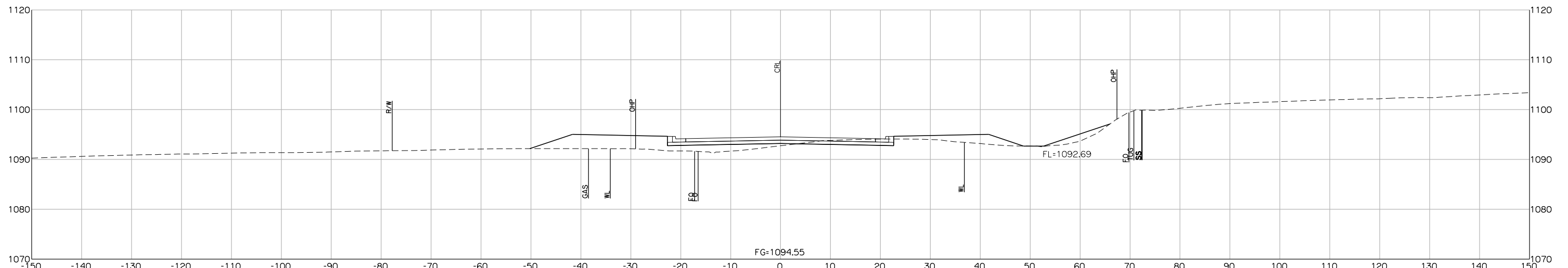
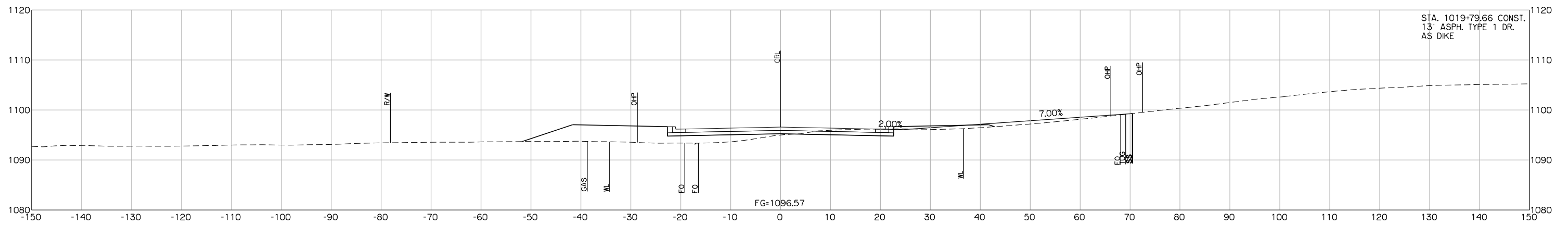
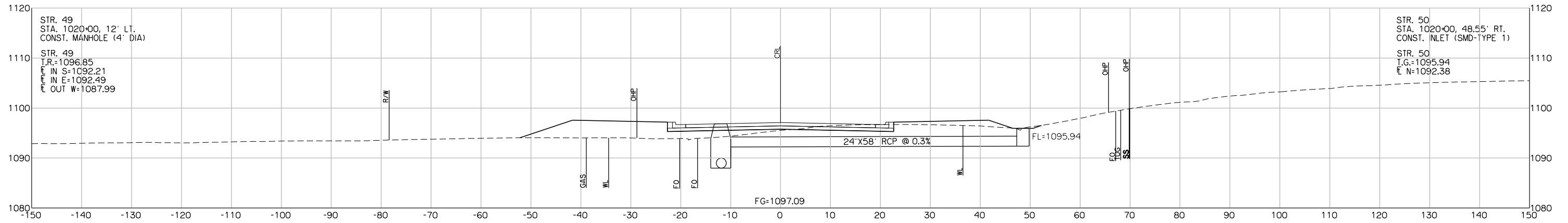

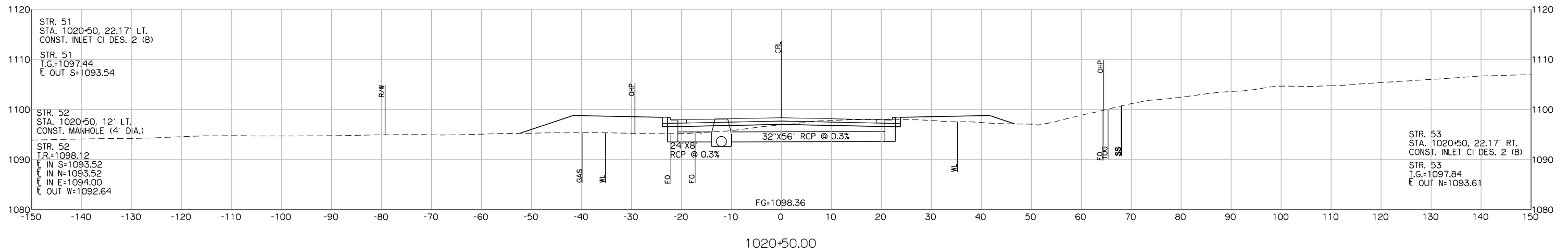
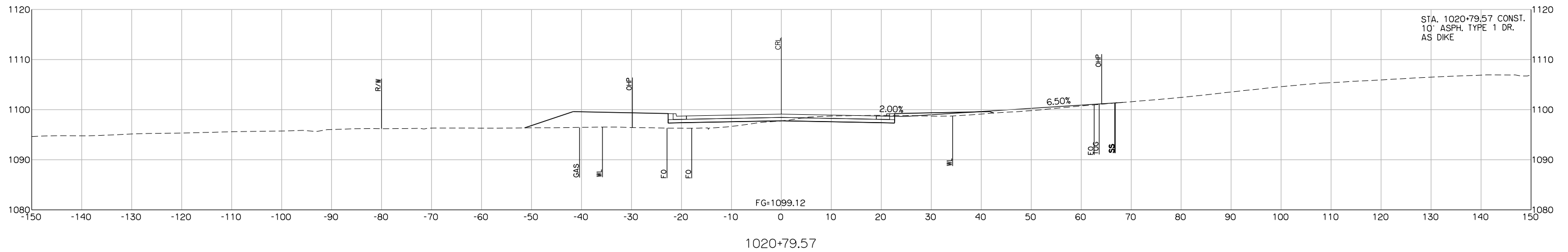
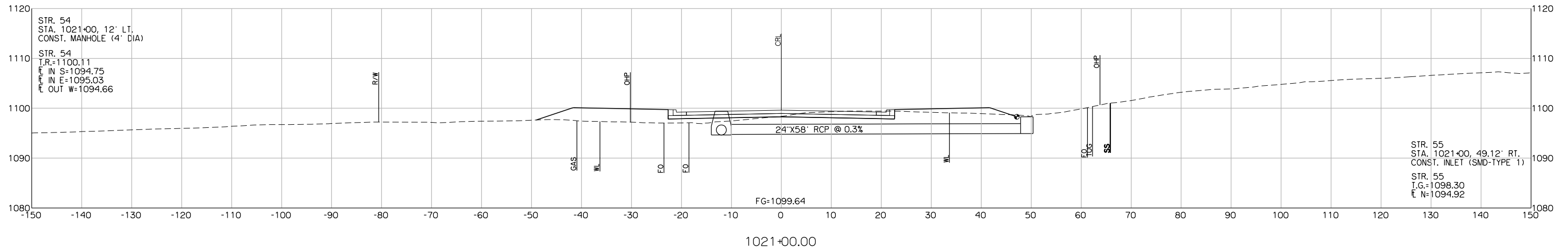

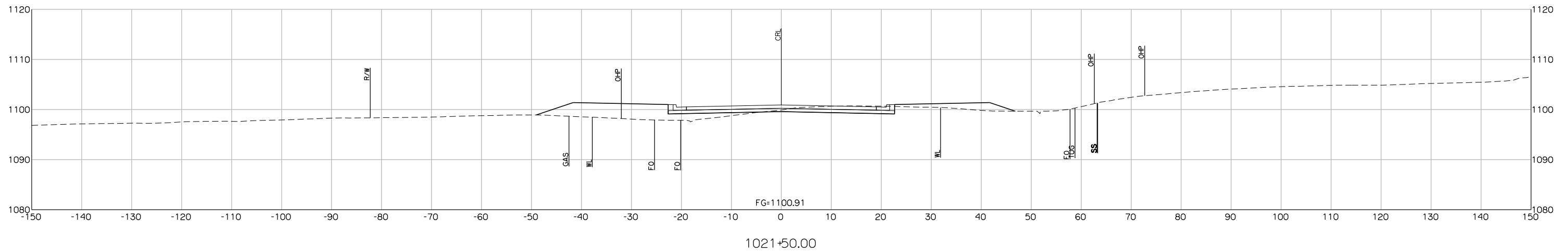
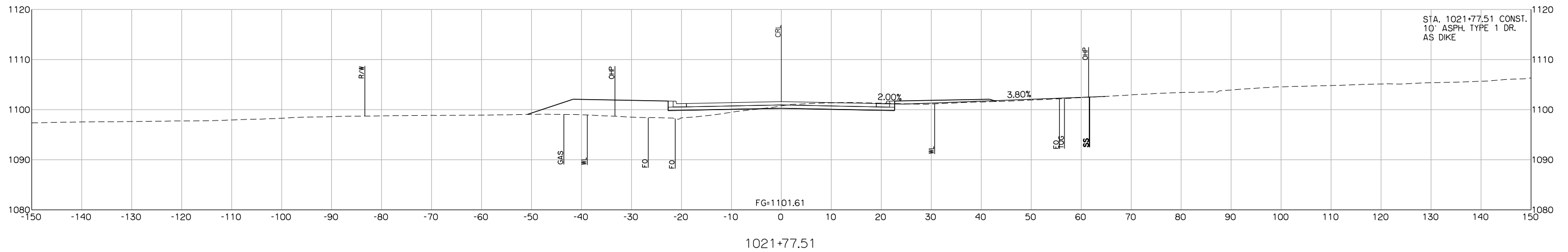
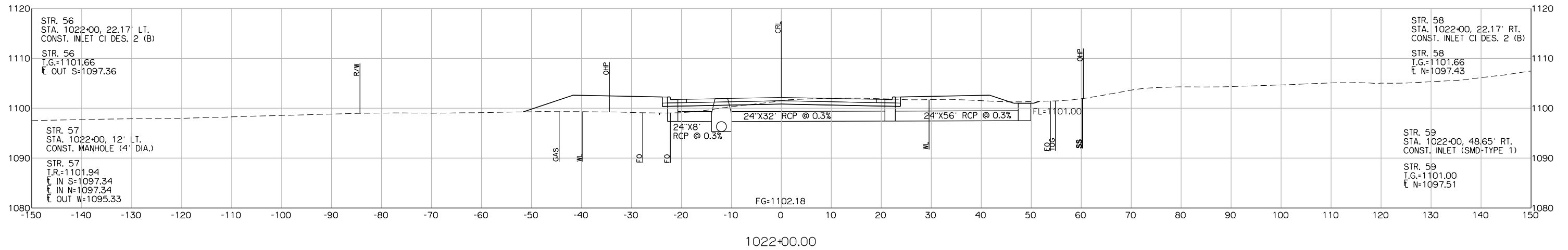

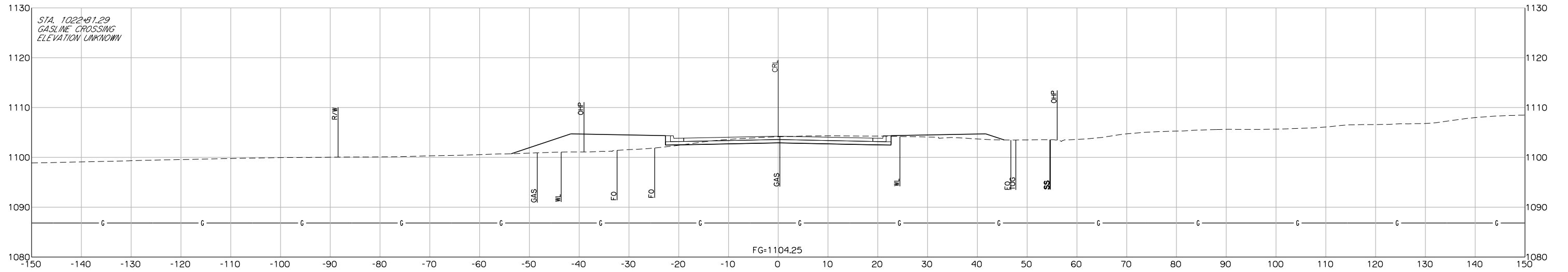

1022+81.29

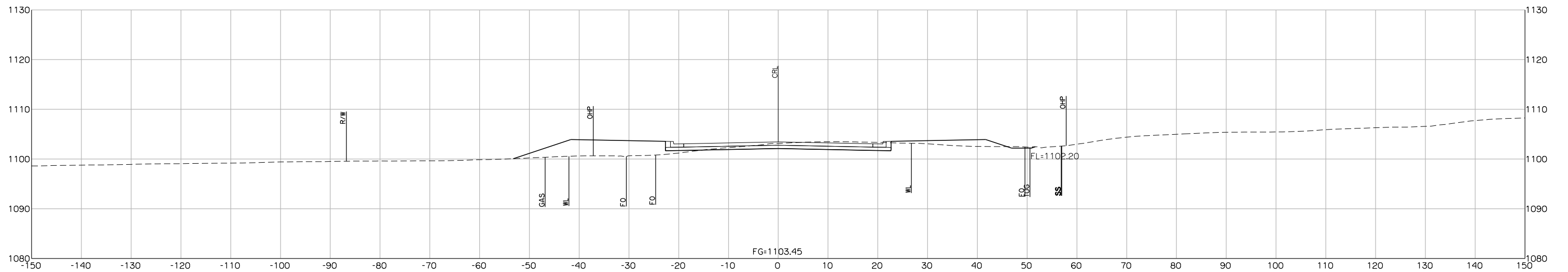

1022+50.00

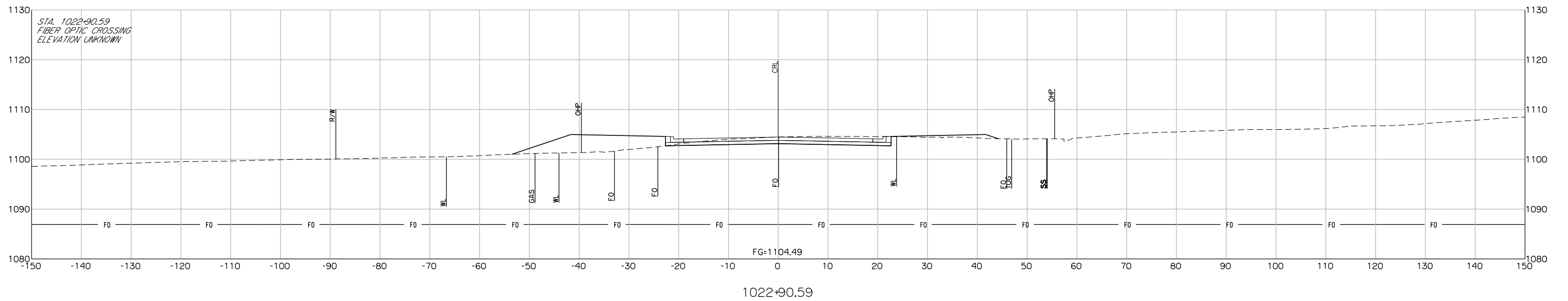
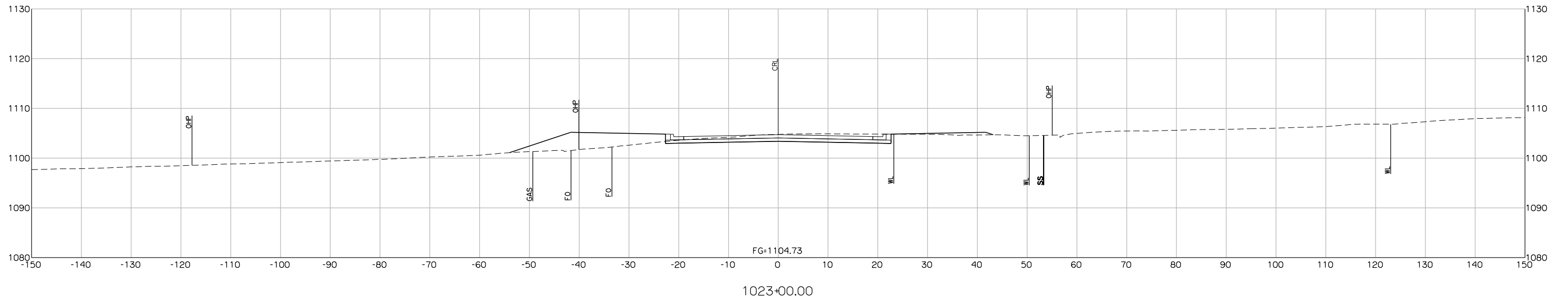

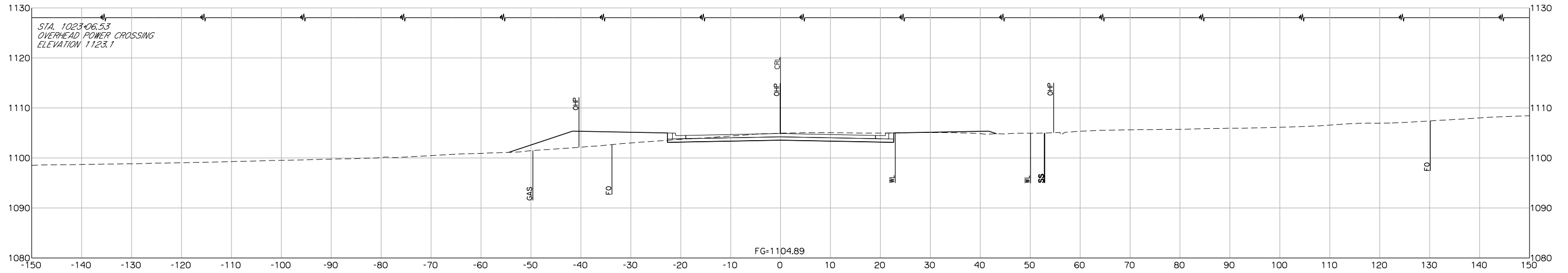

1023+06.53

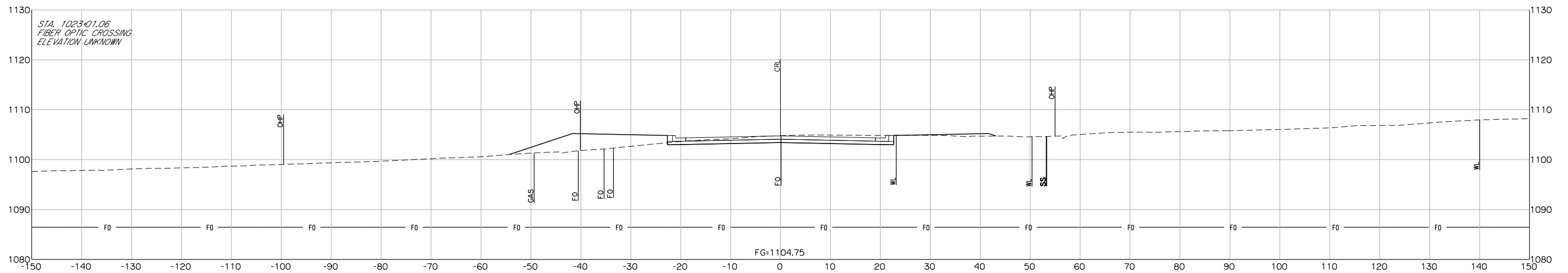

1023+01.06

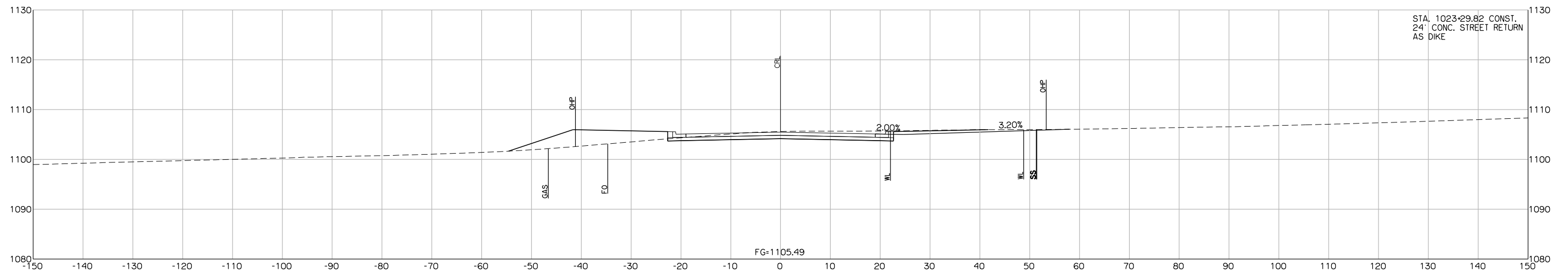

1023+29.82

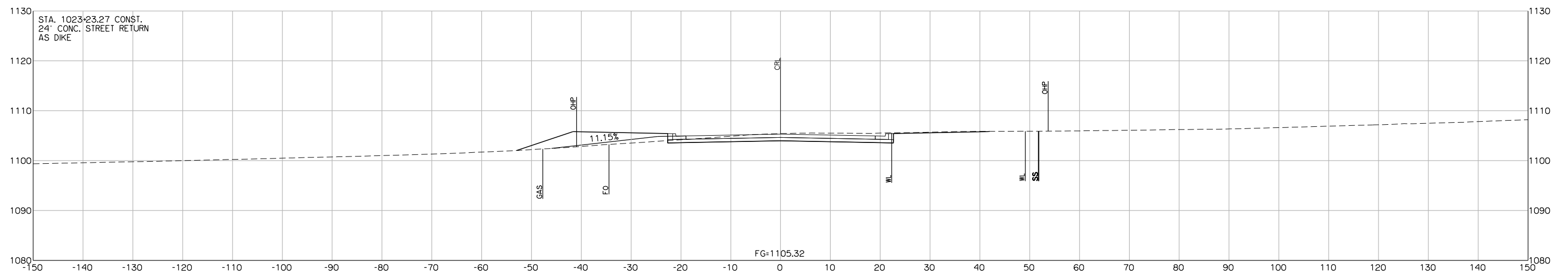

1023+23.27

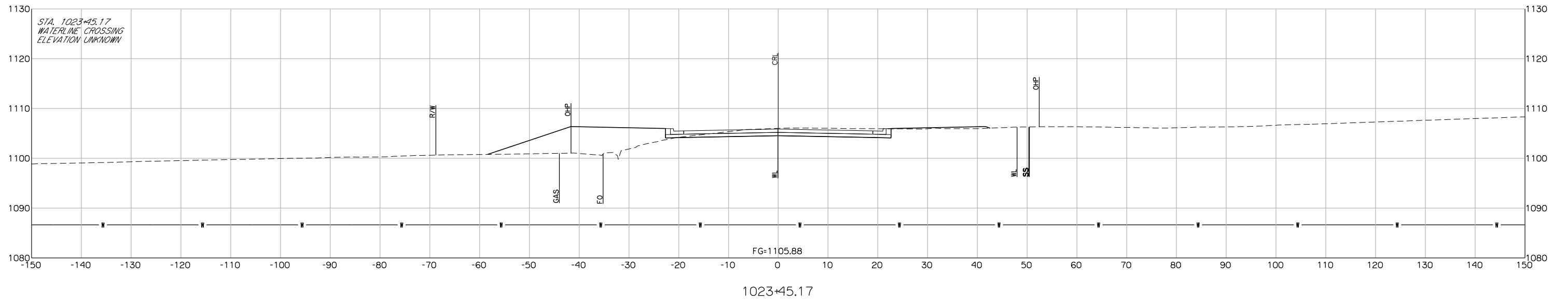
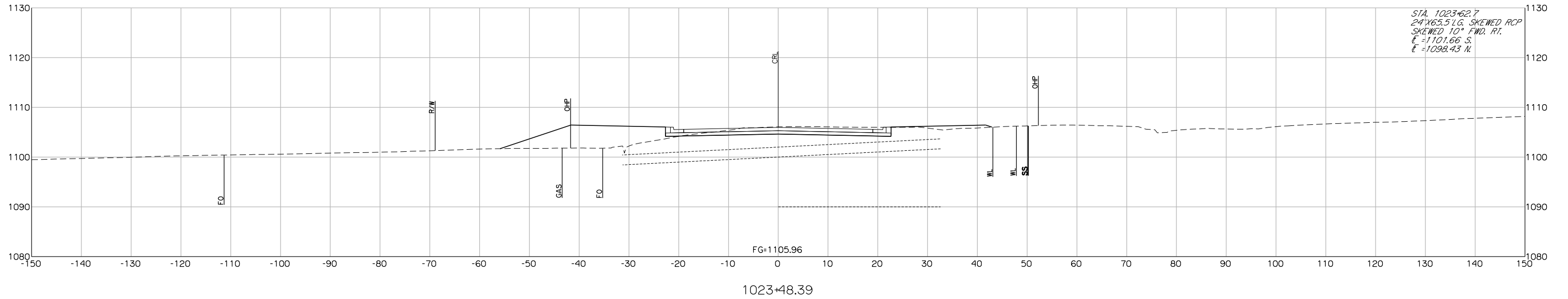
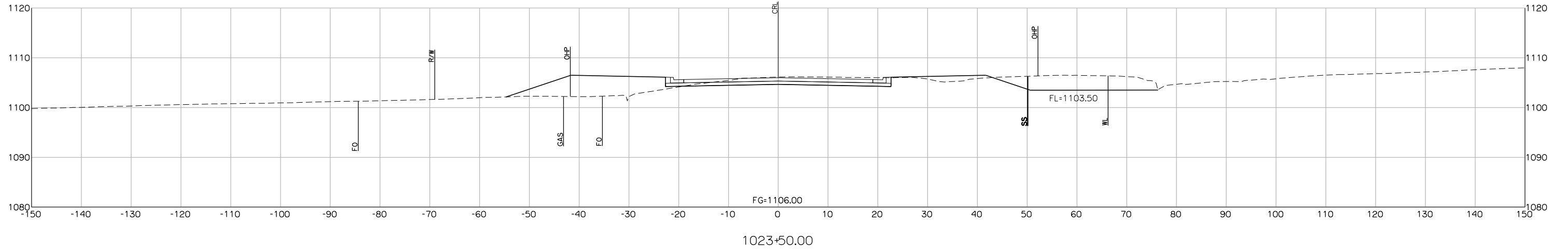

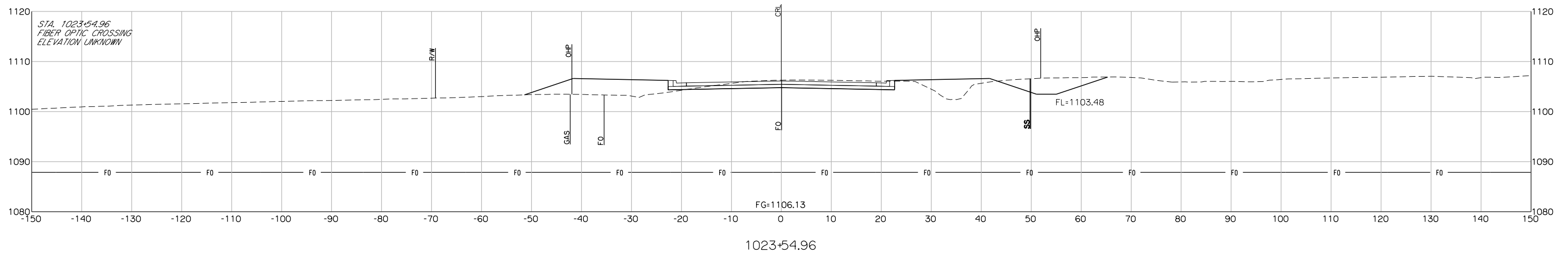
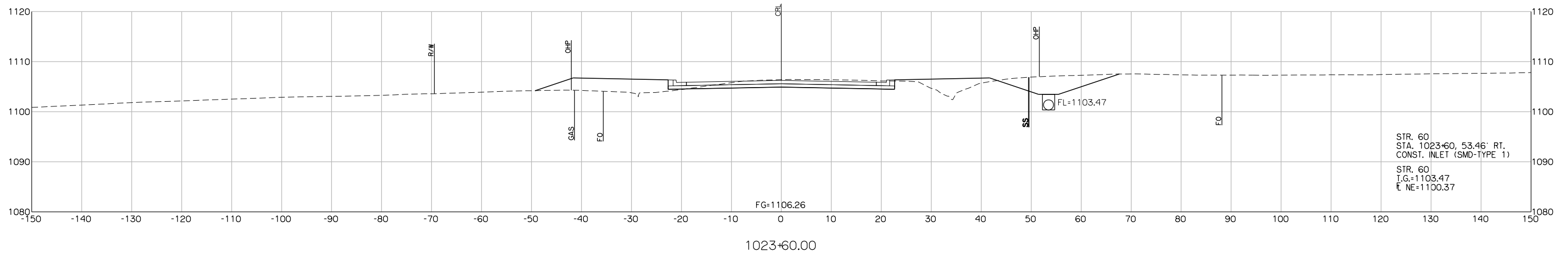
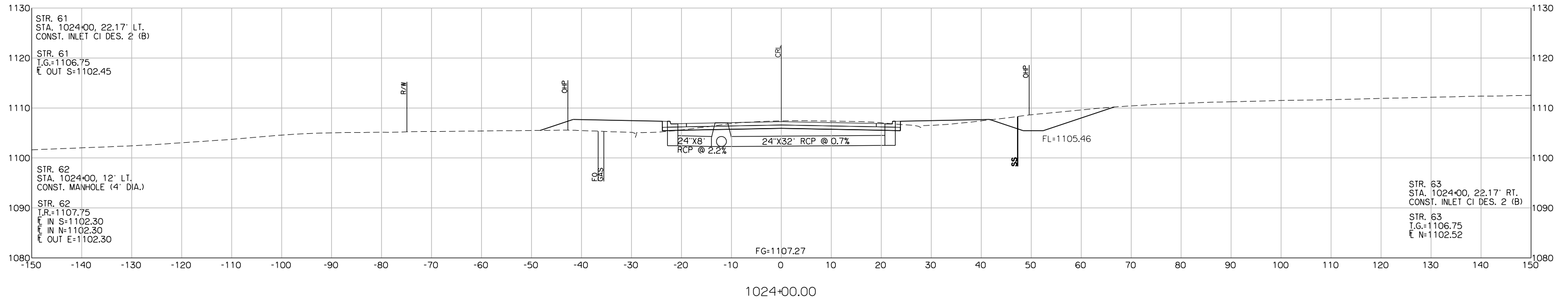

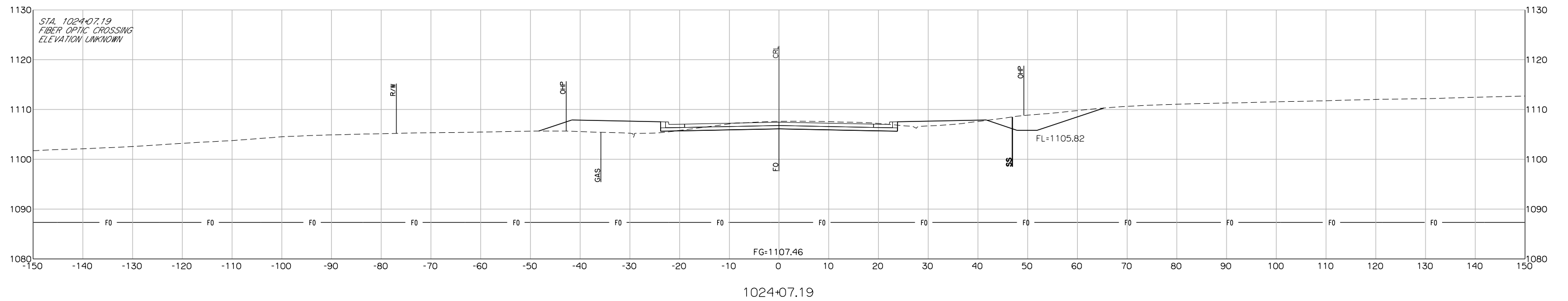
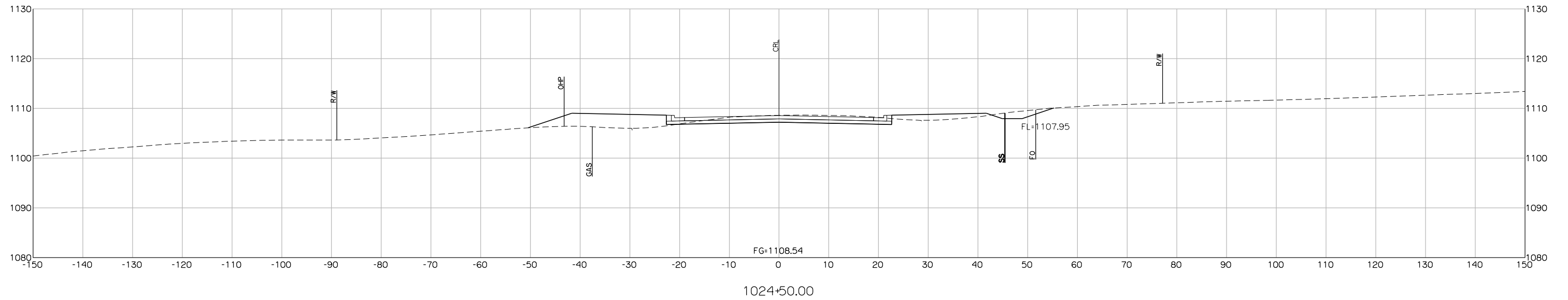

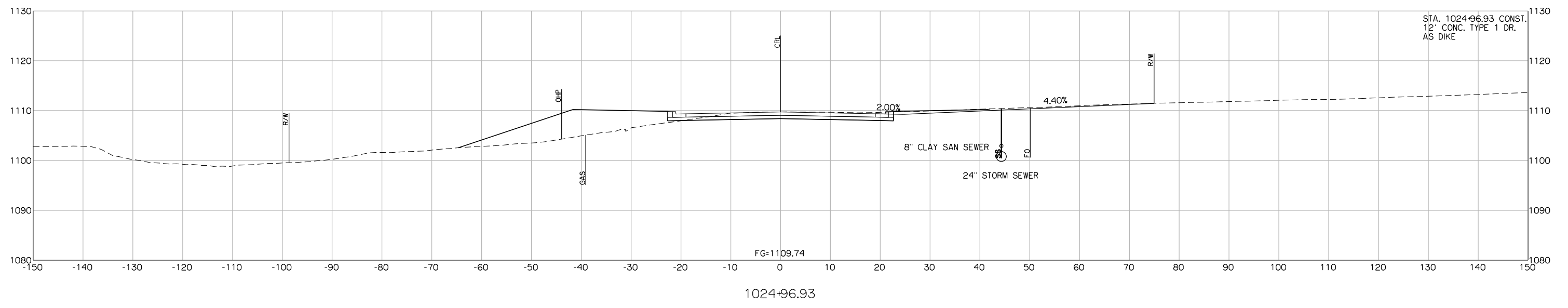
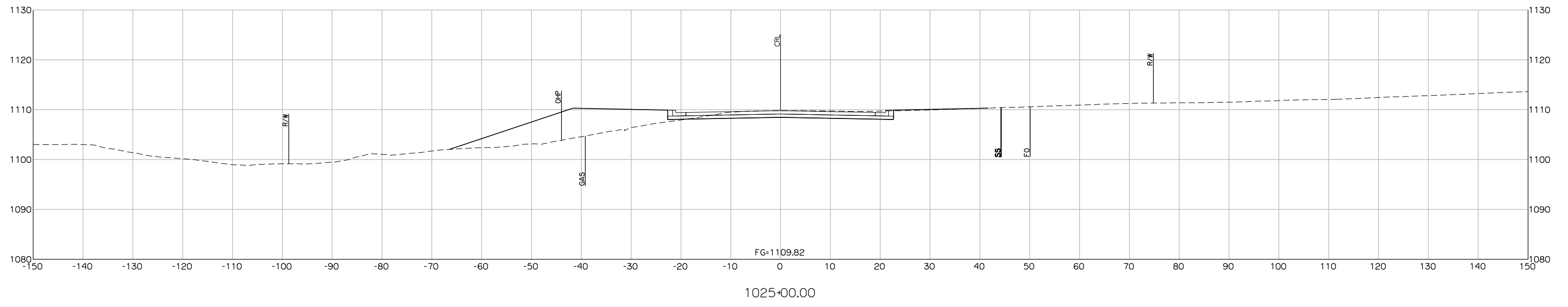

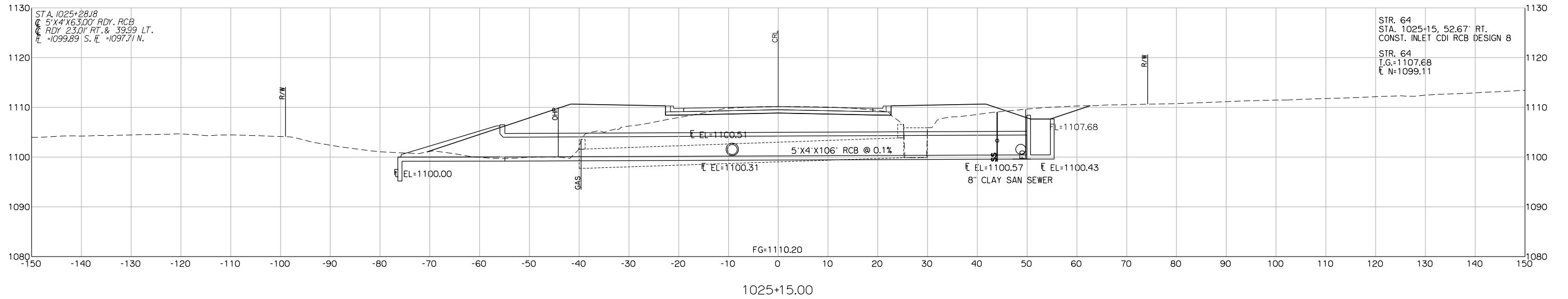
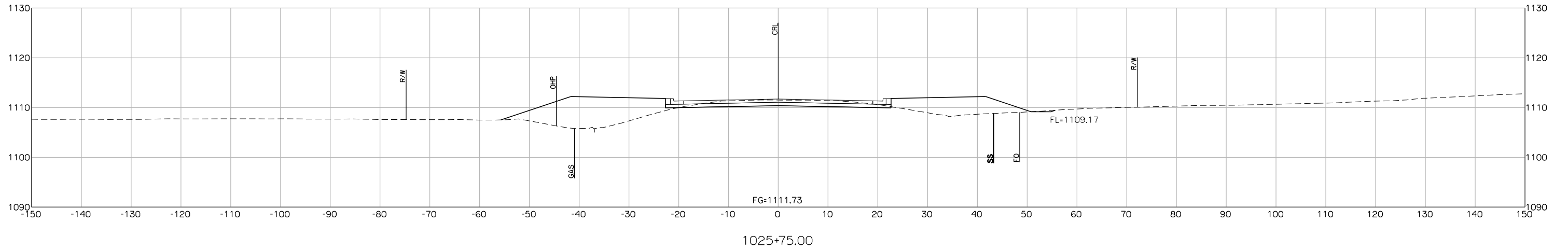

STA. 1025+28.18
 5'x4'x106' RCB
 R.D.Y. 23.01' RT. & 39.99' LT.
 I.L. +1099.89 S. I.L. +1097.71 N.

STR. 64
 STA. 1025+15, 52.67' RT.
 CONST. INLET CDI RCB DESIGN 8
 STR. 64
 I.G.=1107.68
 I.N.=1099.11

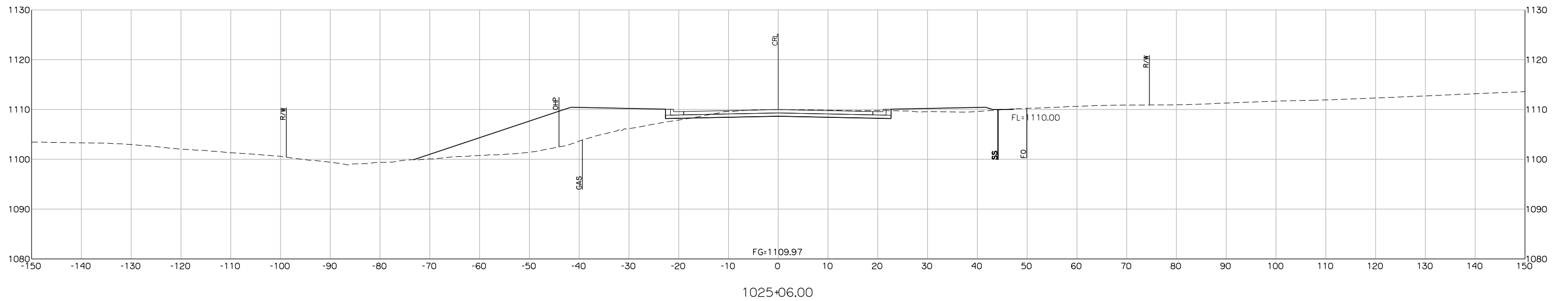

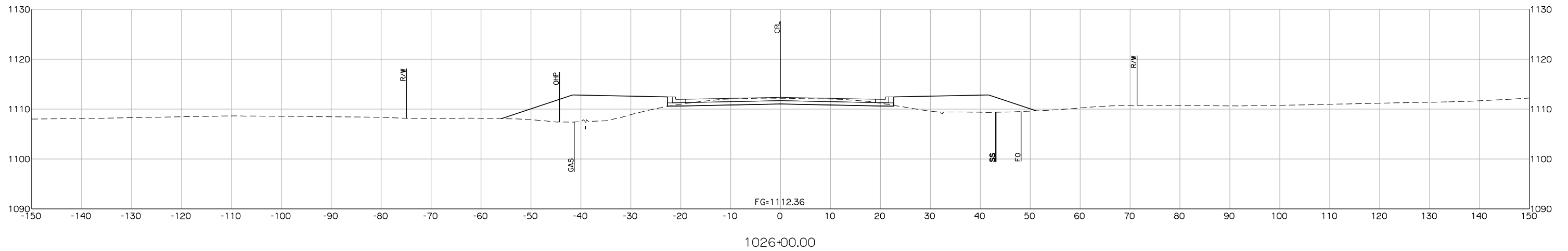
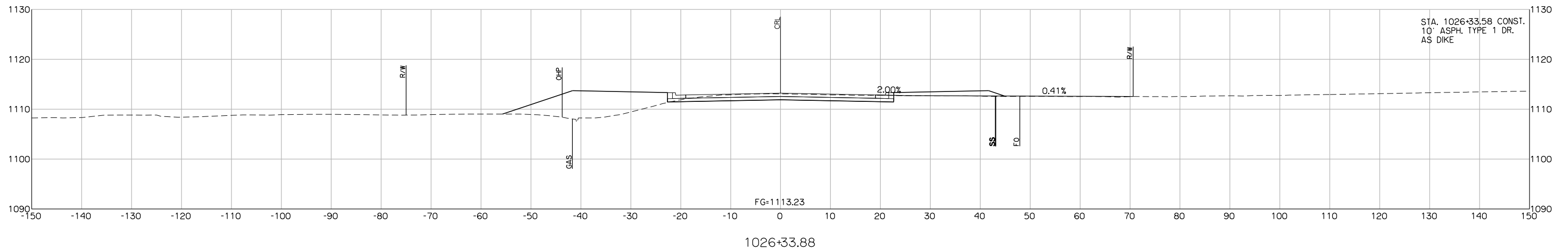
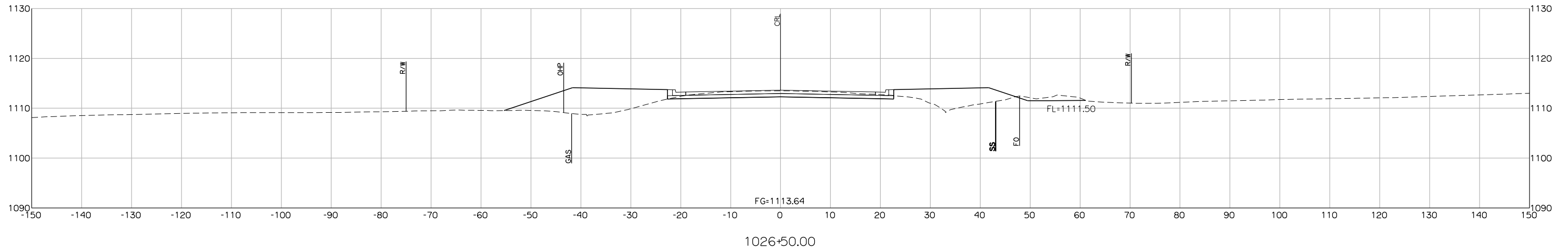

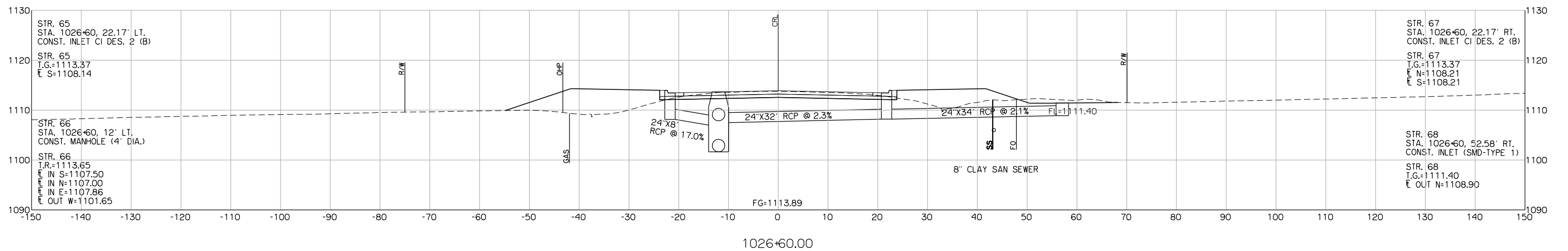
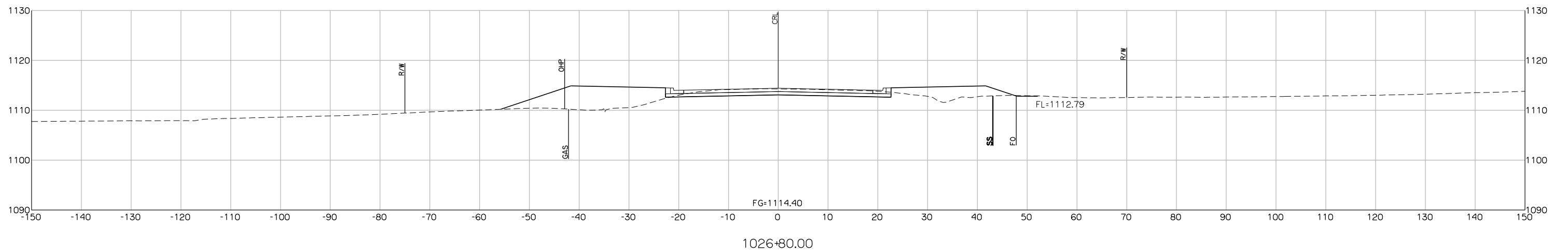
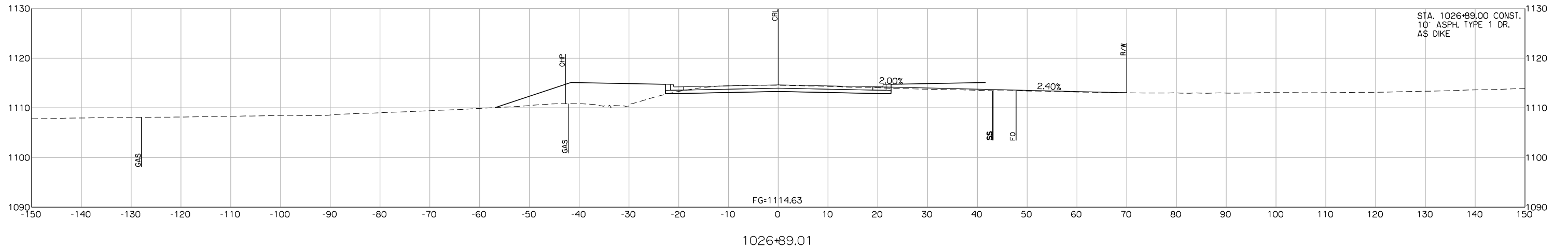

STR. 65
STA. 1026+60, 22.17' LT.
CONST. INLET CI DES. 2 (B)

STR. 65
I.G.=1113.37
E S=1108.14

STR. 66
STA. 1026+60, 12' LT.
CONST. MANHOLE (4' DIA.)

STR. 66
I.R.=1113.65
E IN S=1107.50
E IN N=1107.00
E IN E=1107.86
E OUT W=1101.65

STR. 67
STA. 1026+60, 22.17' RT.
CONST. INLET CI DES. 2 (B)

STR. 67
I.G.=1113.37
E N=1108.21
E S=1108.21

STR. 68
STA. 1026+60, 52.58' RT.
CONST. INLET (SMD-TYPE 1)

STR. 68
I.G.=1111.40
E OUT N=1108.90

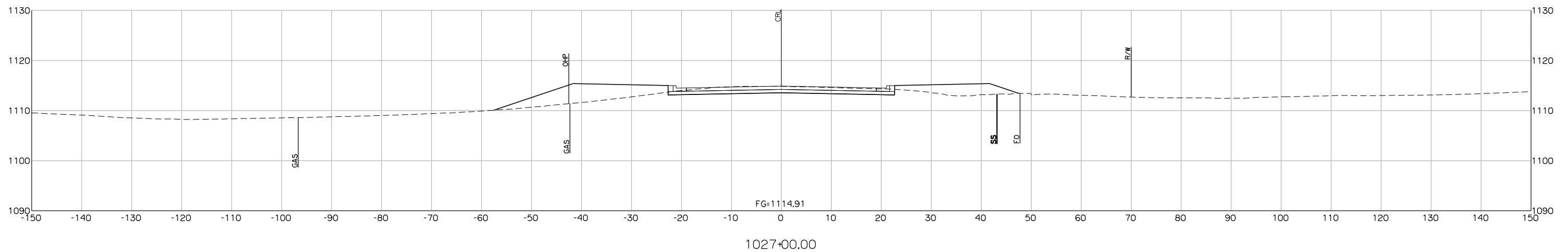
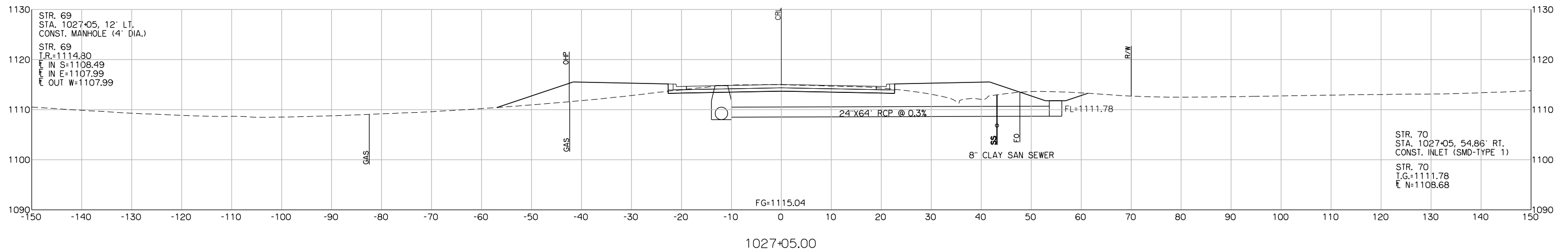
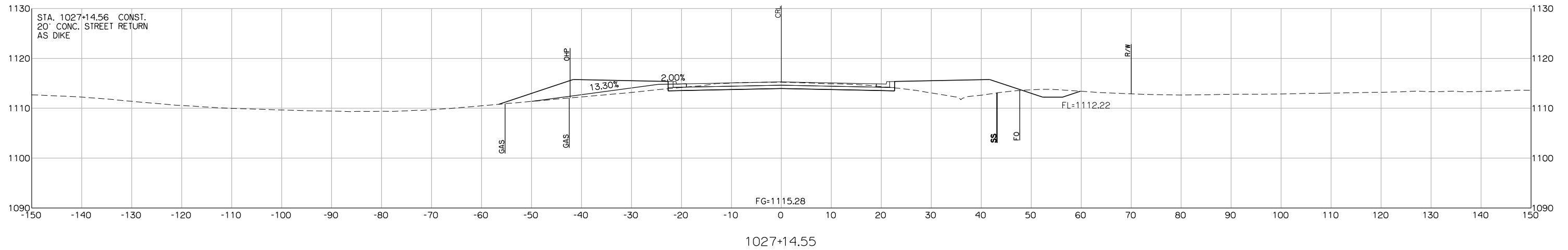

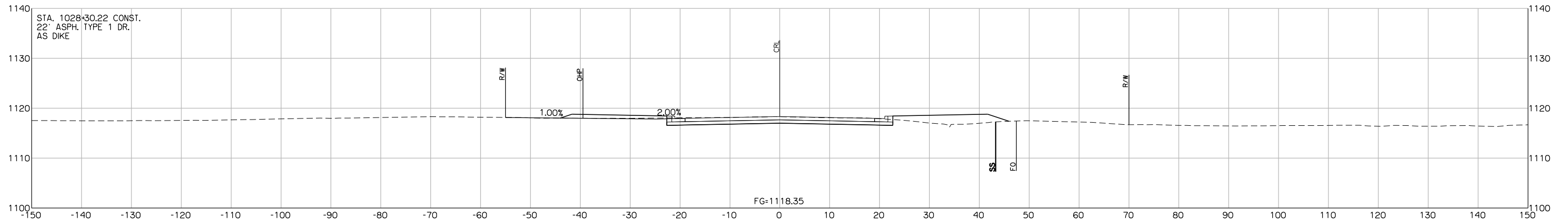

1028+30.22

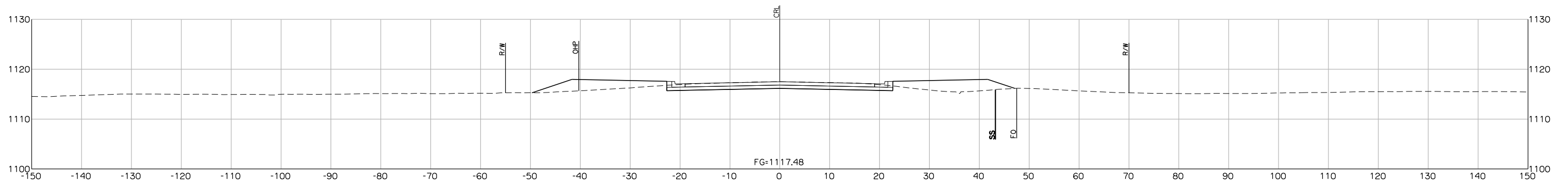

1028+00.00

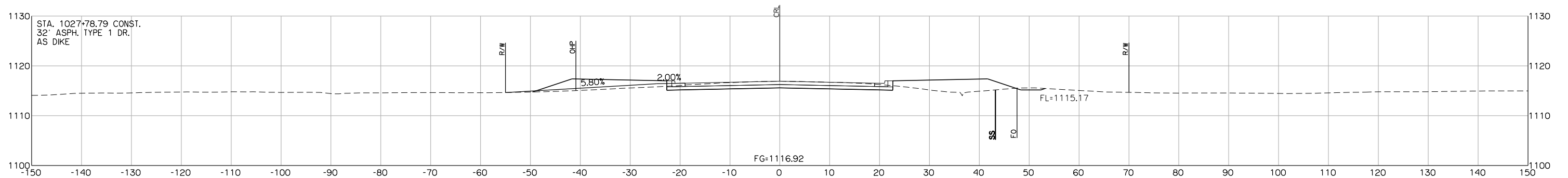

1027+78.79

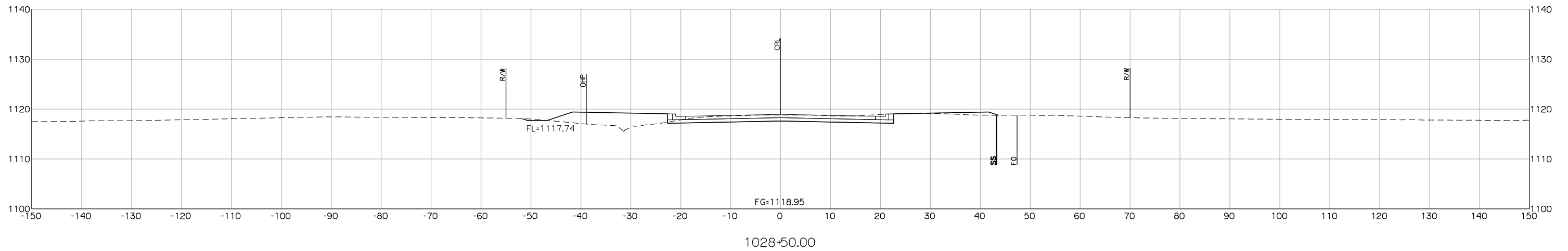
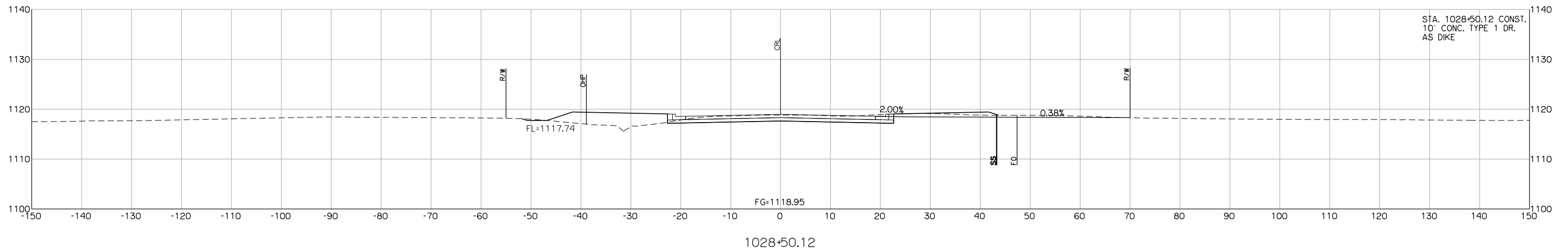
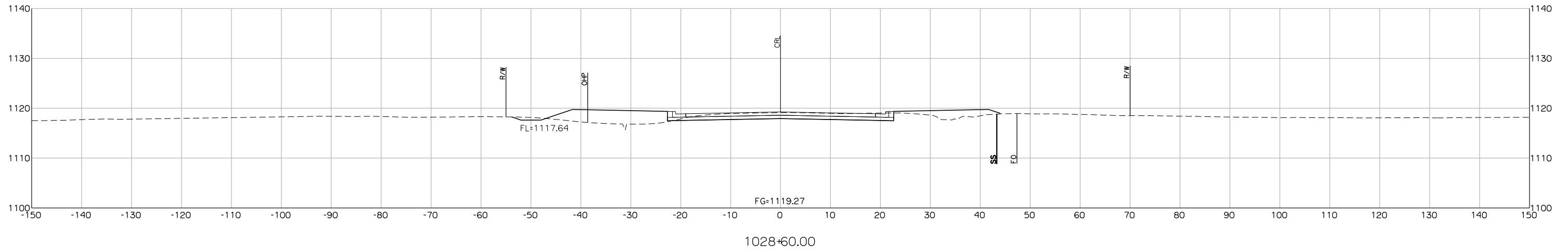

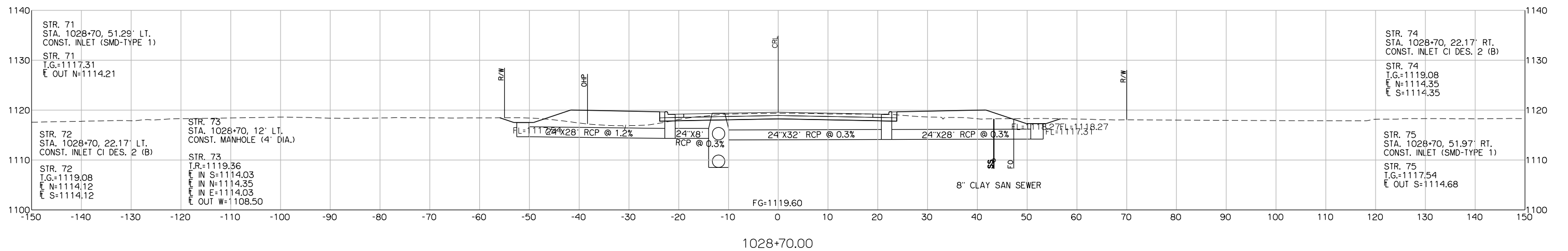
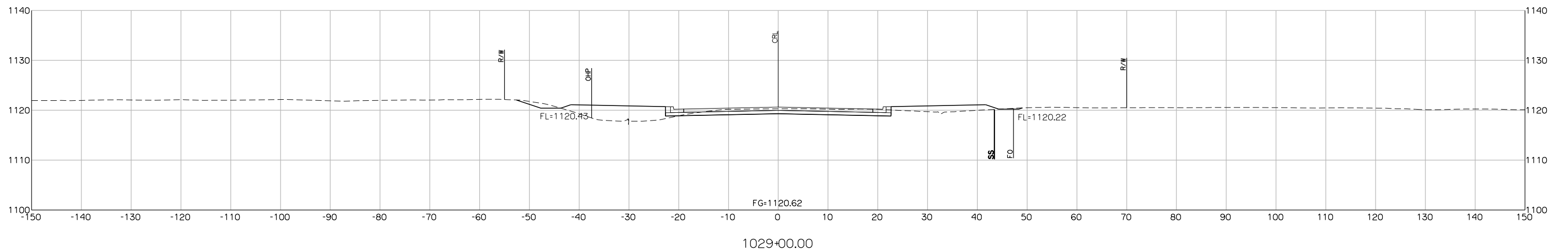
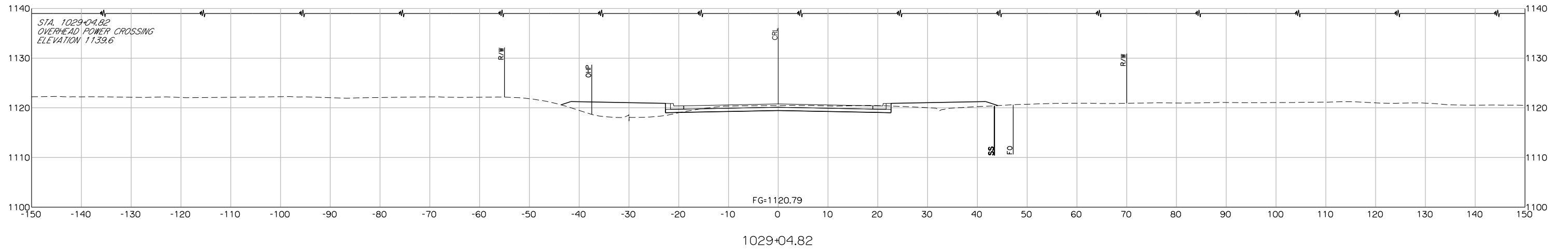

STR. 71
STA. 1028+70, 51.29' LT.
CONST. INLET (SMD-TYPE 1)
STR. 71
I.G.=1117.31
E OUT N=1114.21

STR. 72
STA. 1028+70, 22.17' LT.
CONST. INLET CI DES. 2 (B)
STR. 72
I.G.=1119.08
E N=1114.12
E S=1114.12

STR. 73
STA. 1028+70, 12' LT.
CONST. MANHOLE (4' DIA.)
STR. 73
I.R.=1119.36
E IN S=1114.03
E IN N=1114.35
E IN E=1114.03
E OUT W=1108.50

STR. 74
STA. 1028+70, 22.17' RT.
CONST. INLET CI DES. 2 (B)
STR. 74
I.G.=1119.08
E N=1114.35
E S=1114.35

STR. 75
STA. 1028+70, 51.97' RT.
CONST. INLET (SMD-TYPE 1)
STR. 75
I.G.=1117.54
E OUT S=1114.68

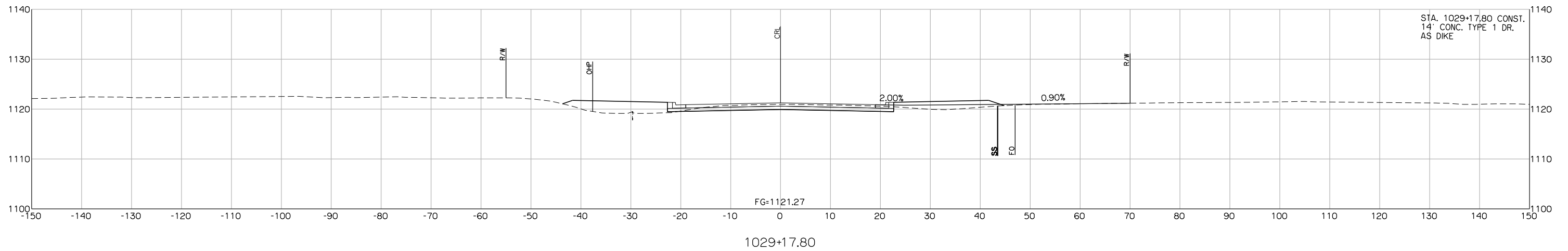
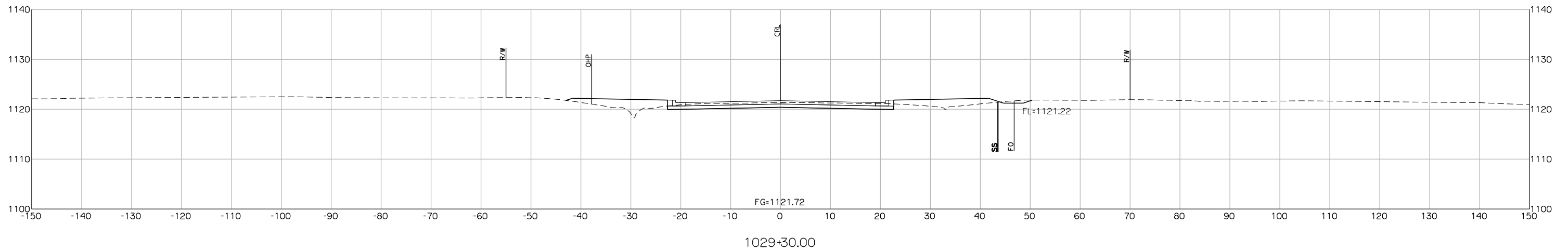
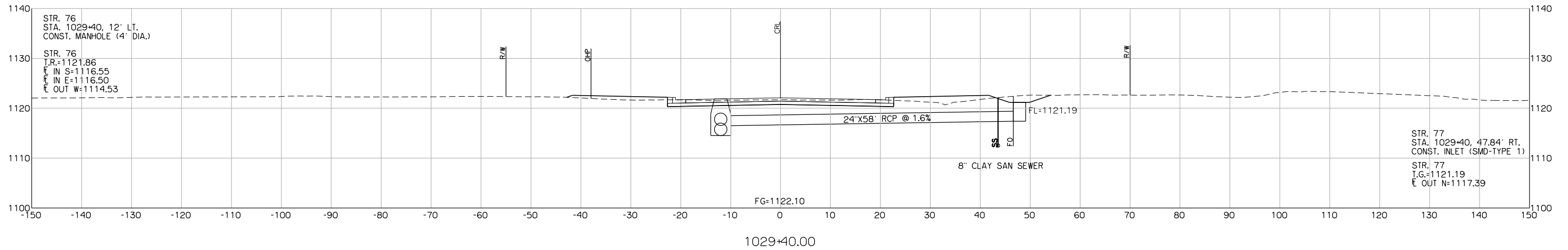

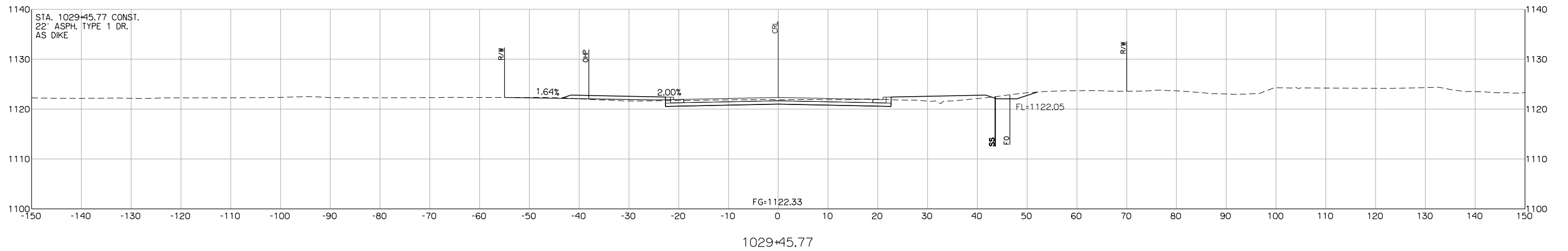
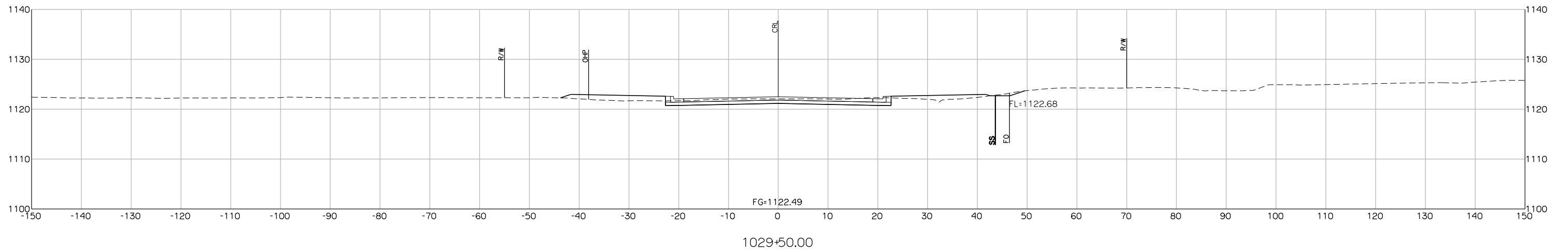
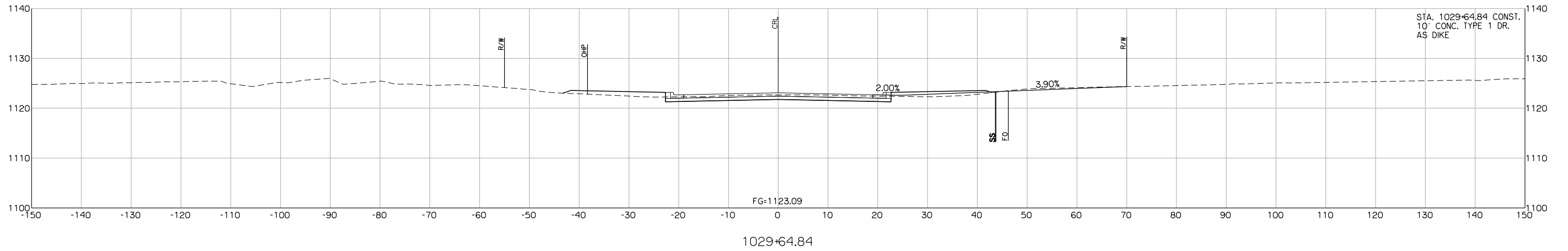

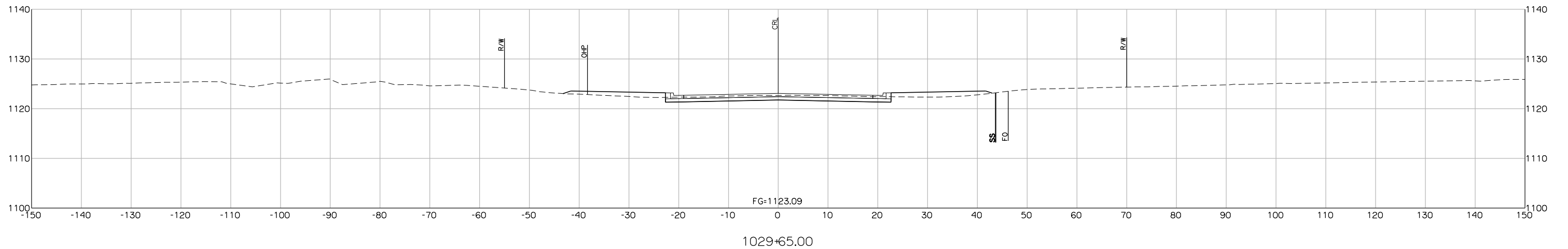
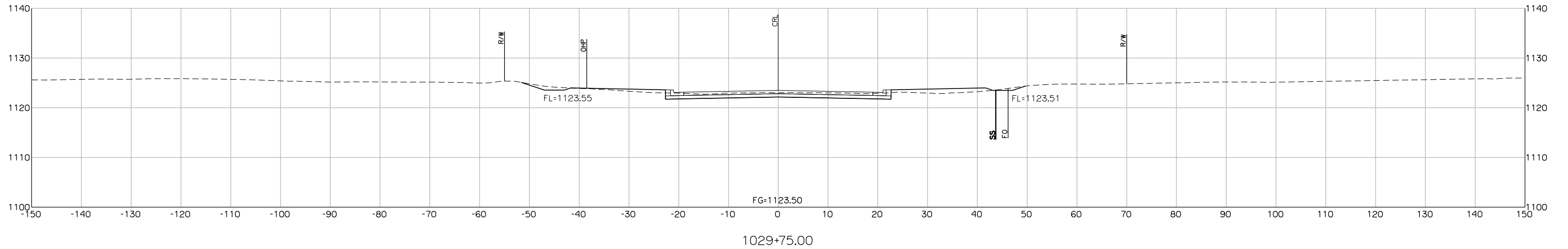
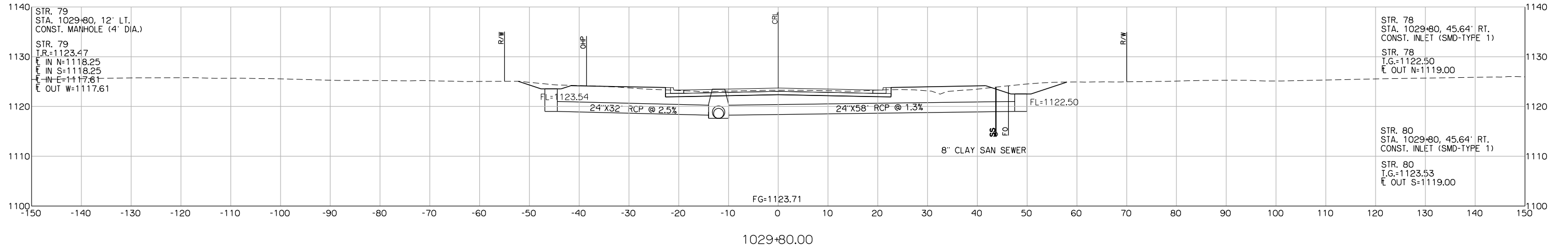

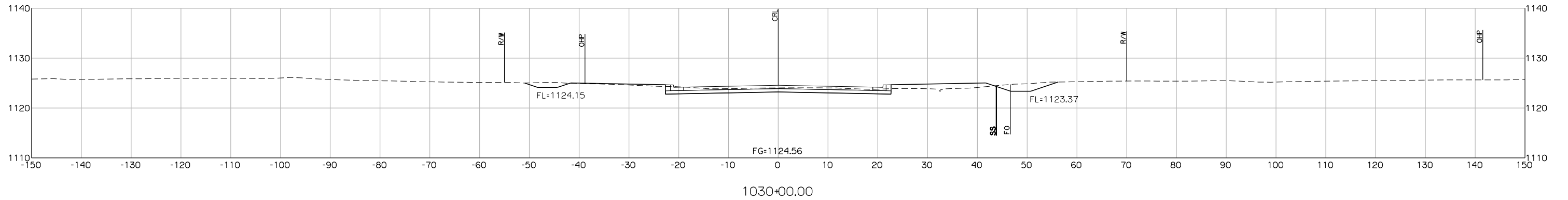
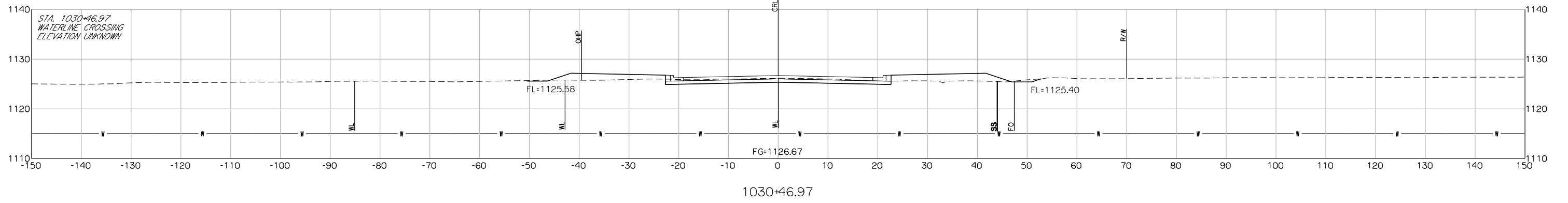
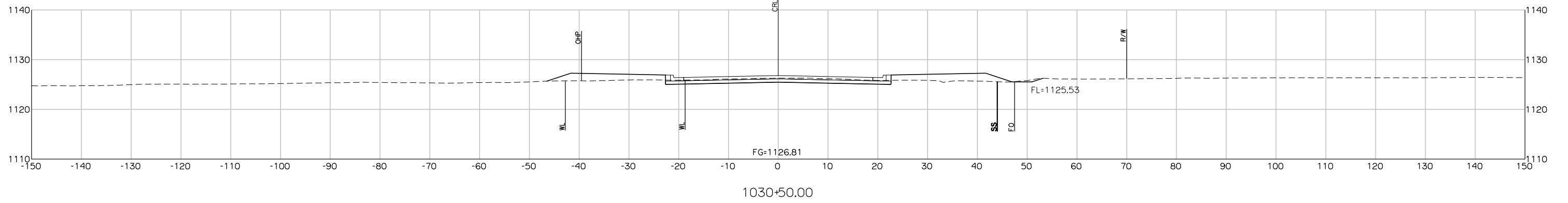
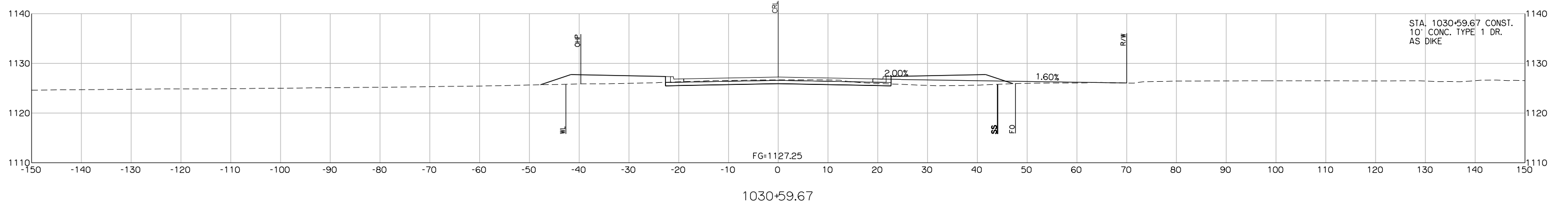

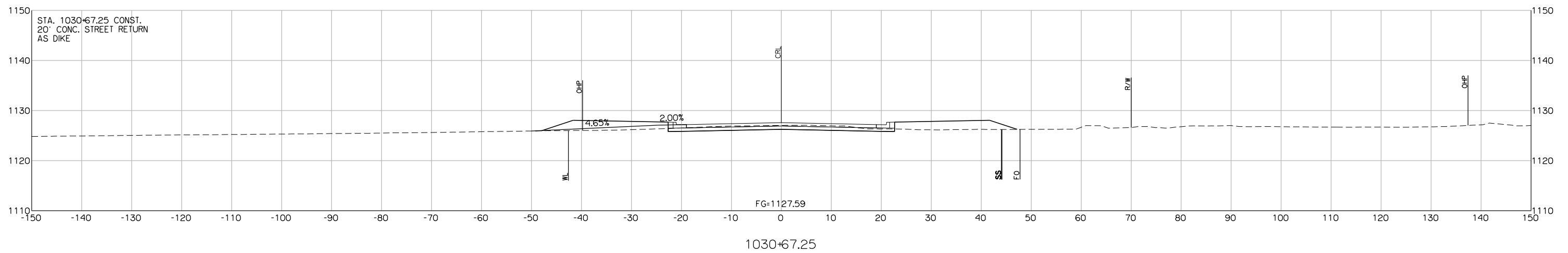
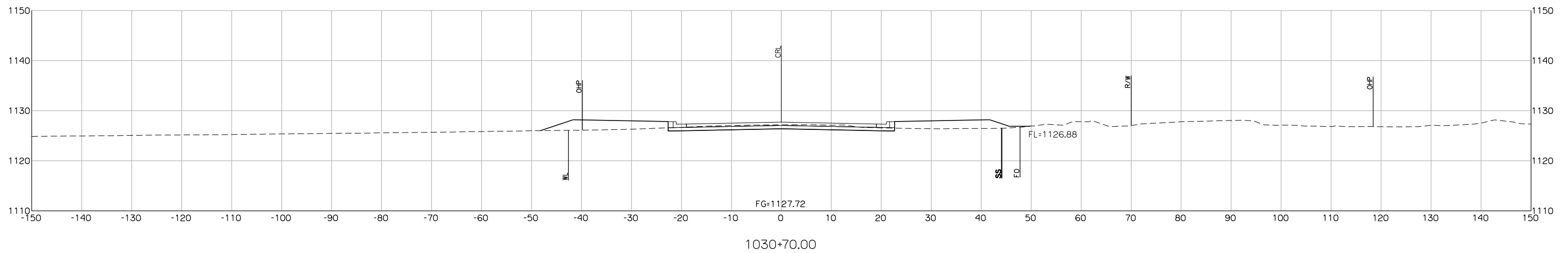
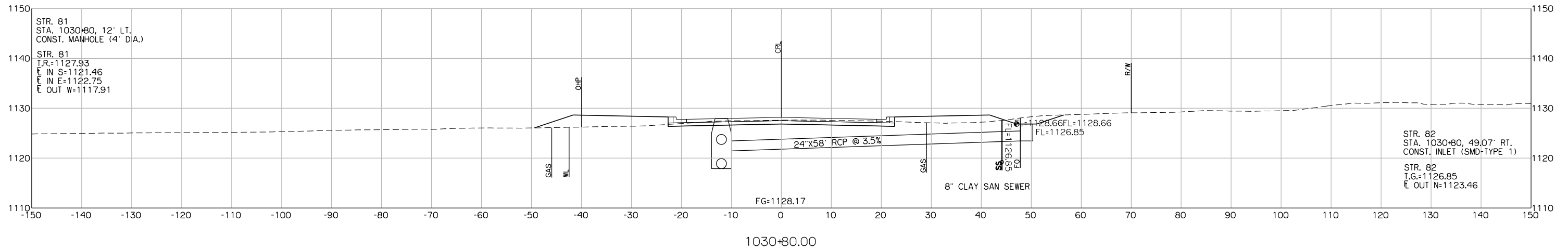

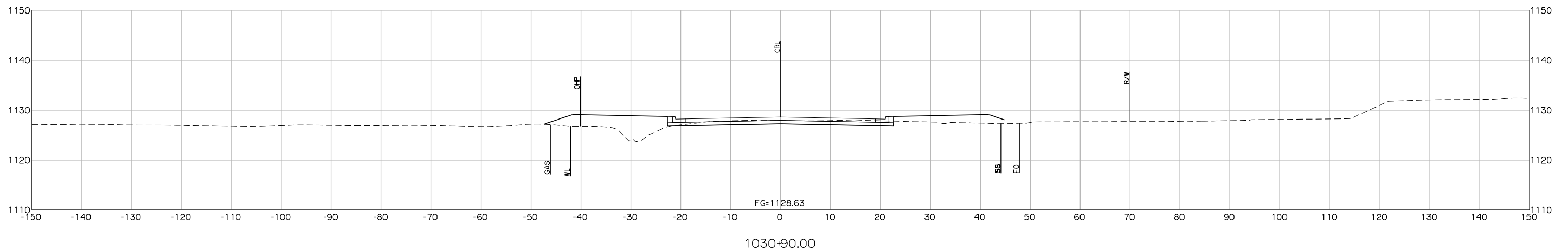
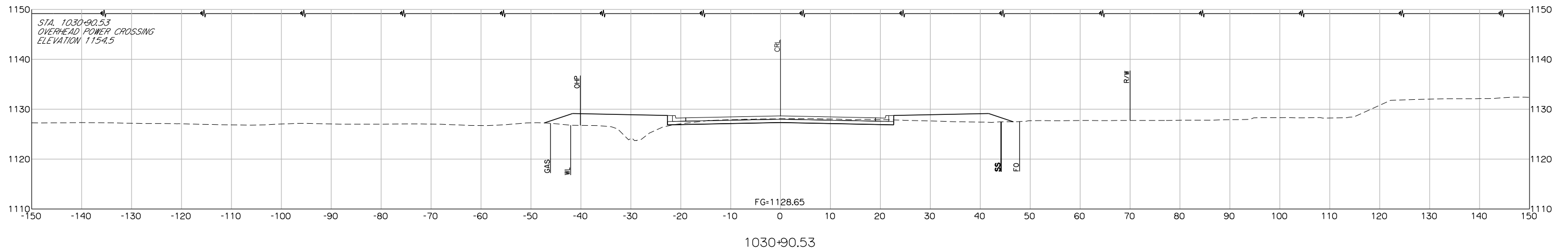
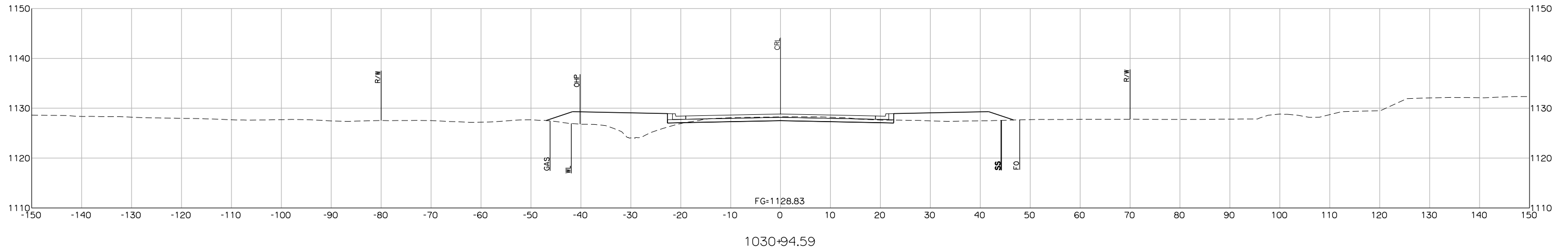

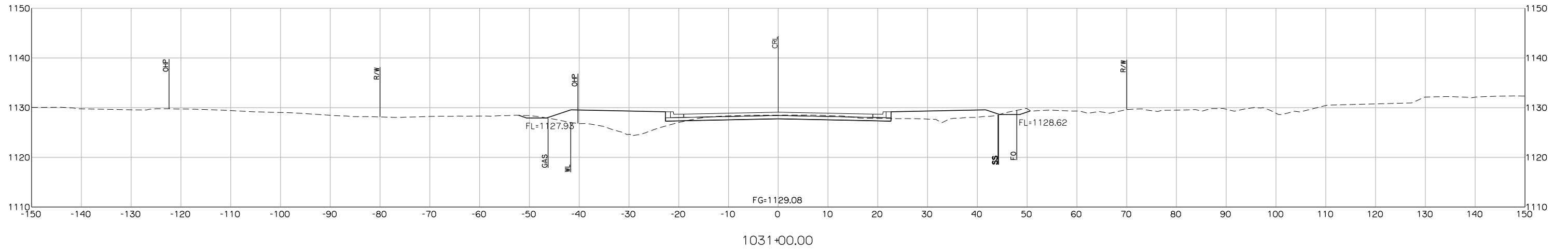
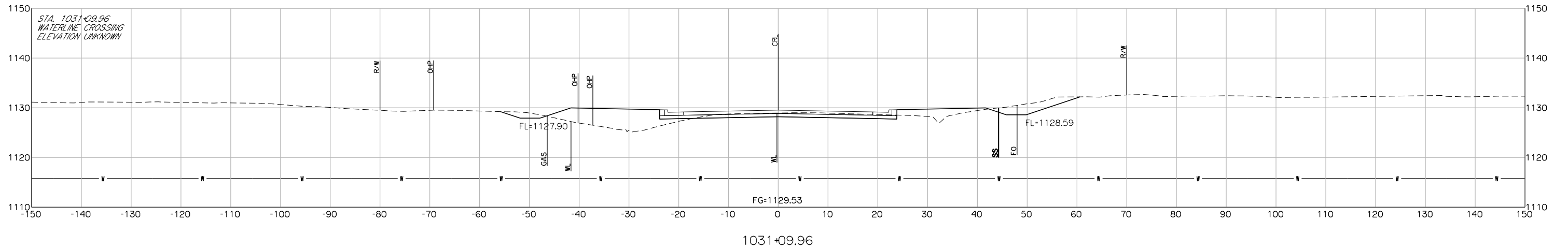
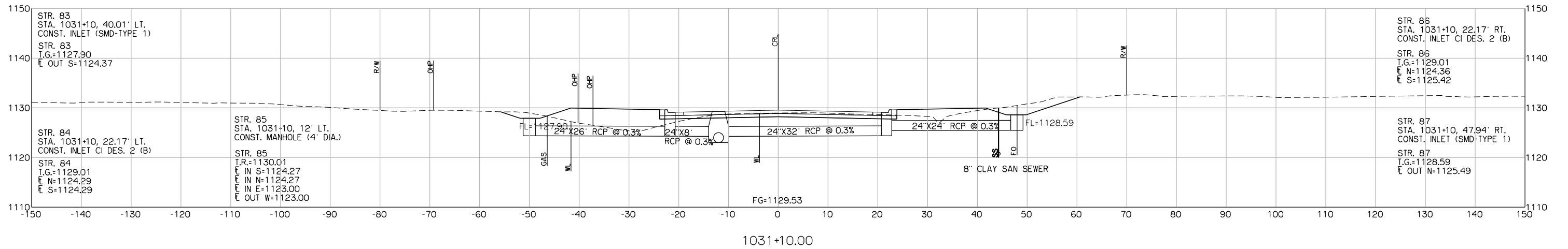

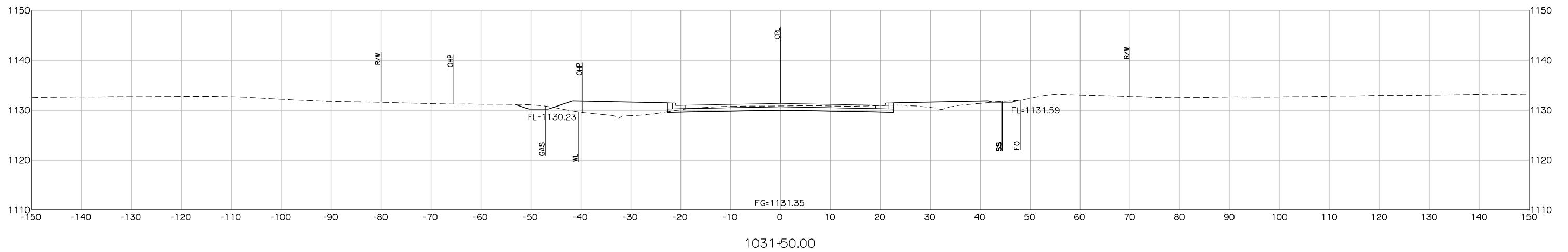
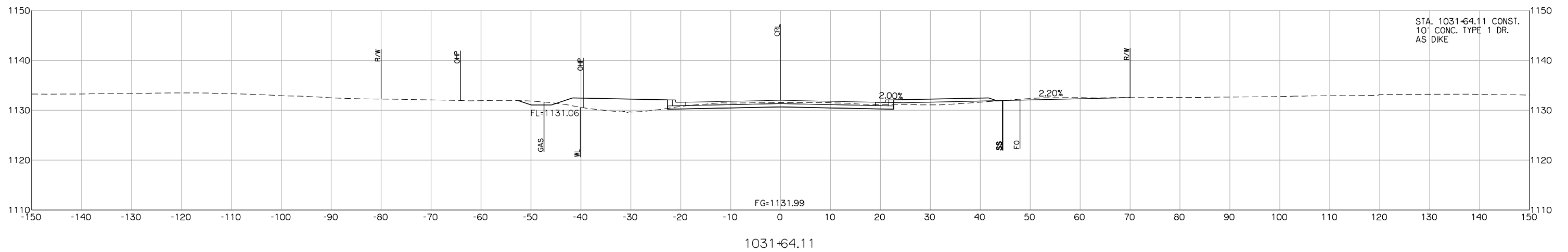
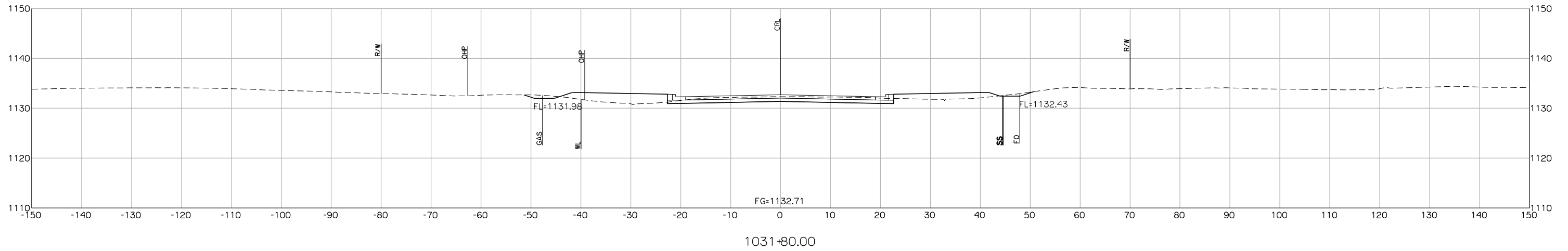

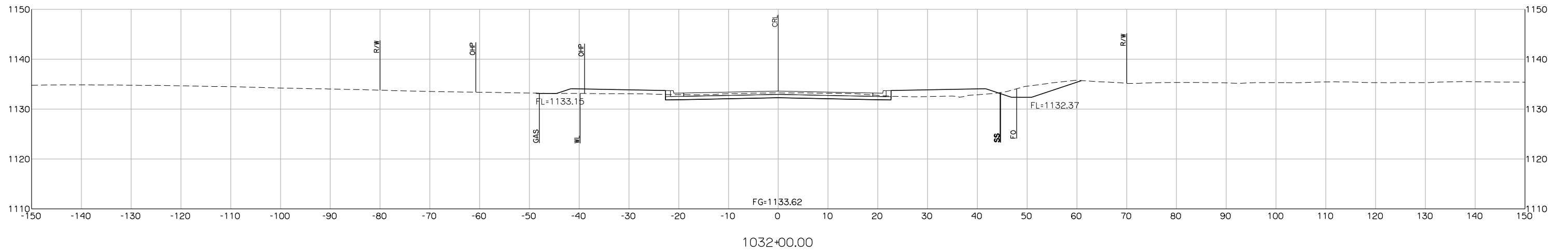
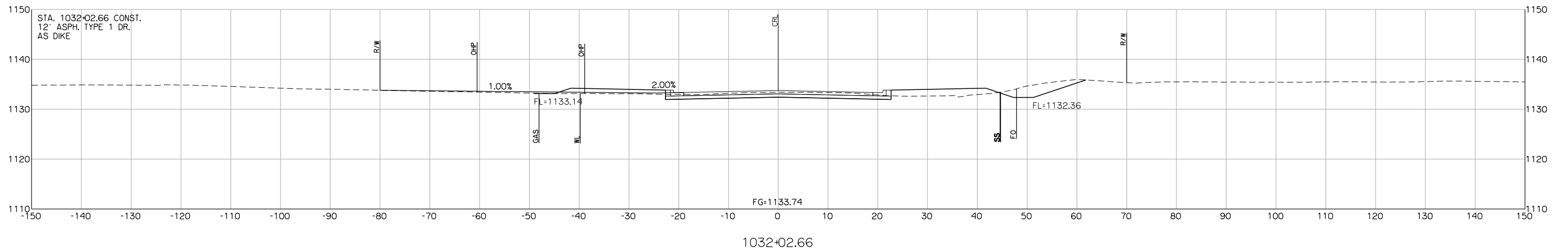
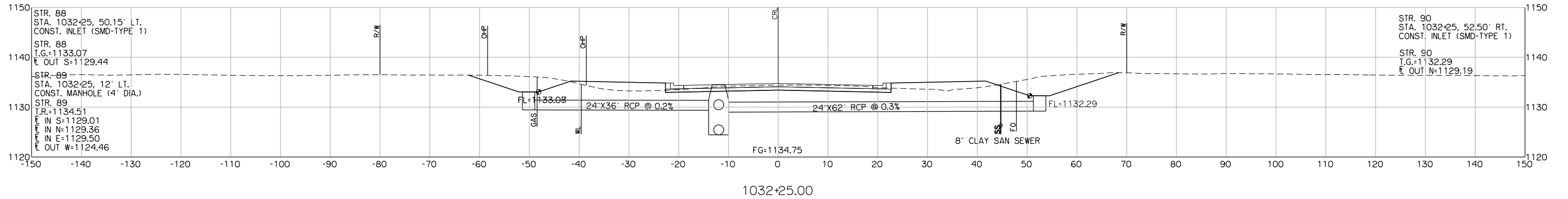

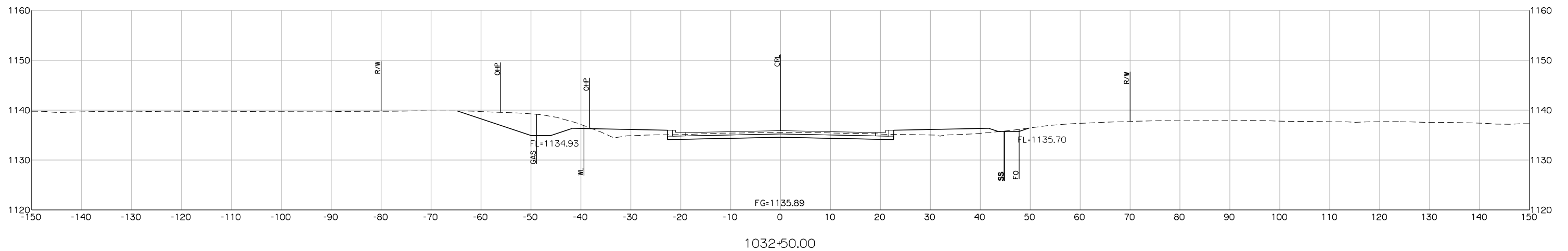
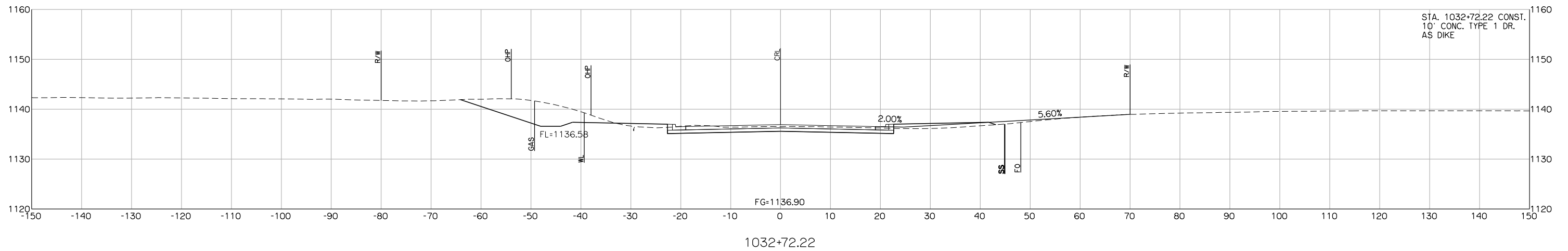
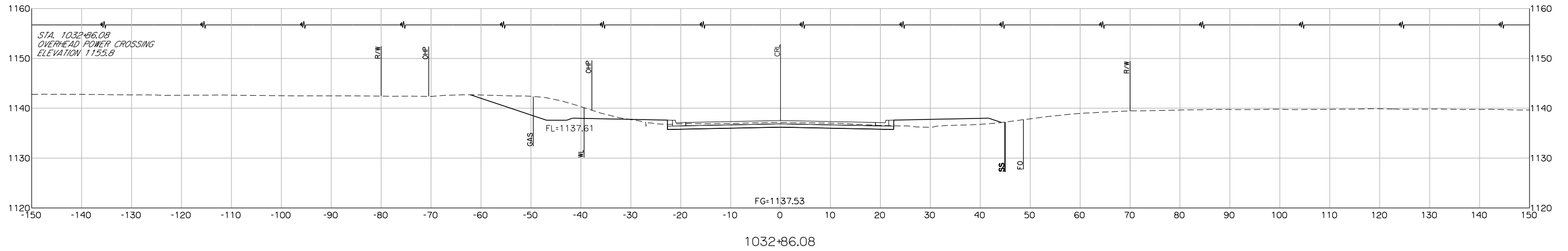

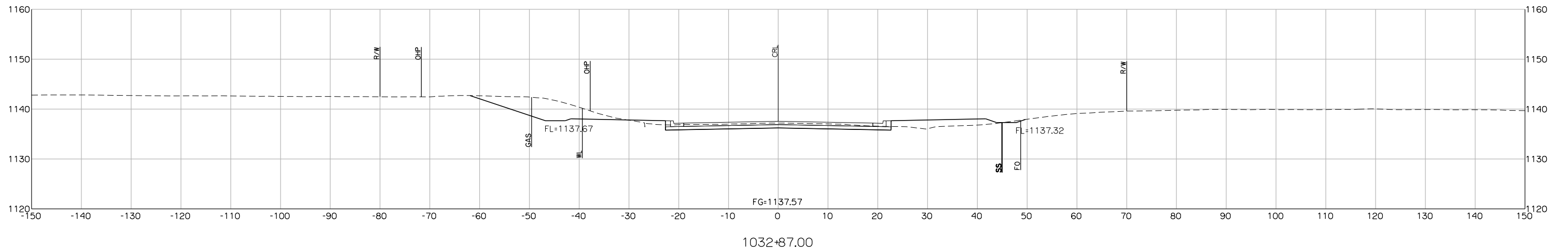
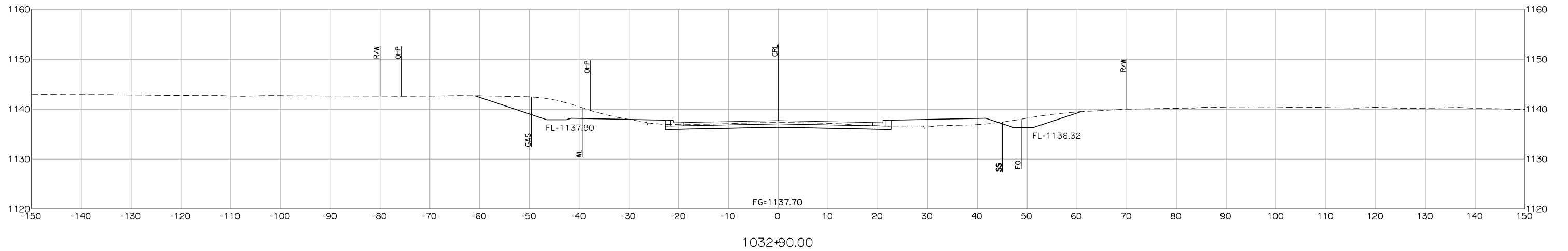
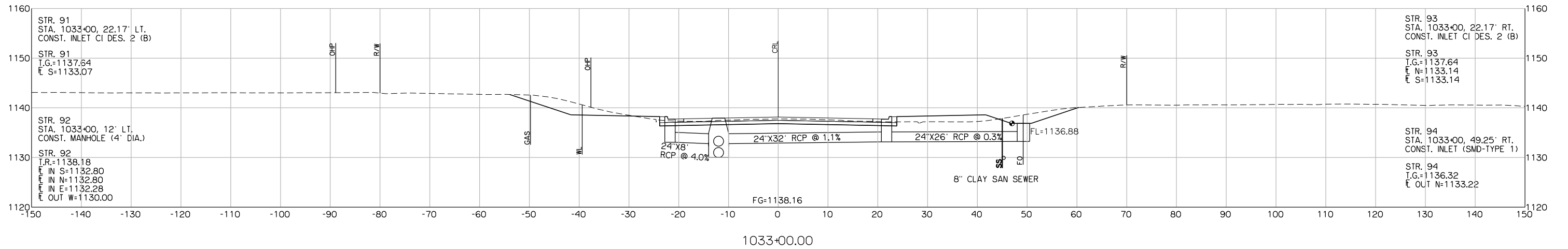

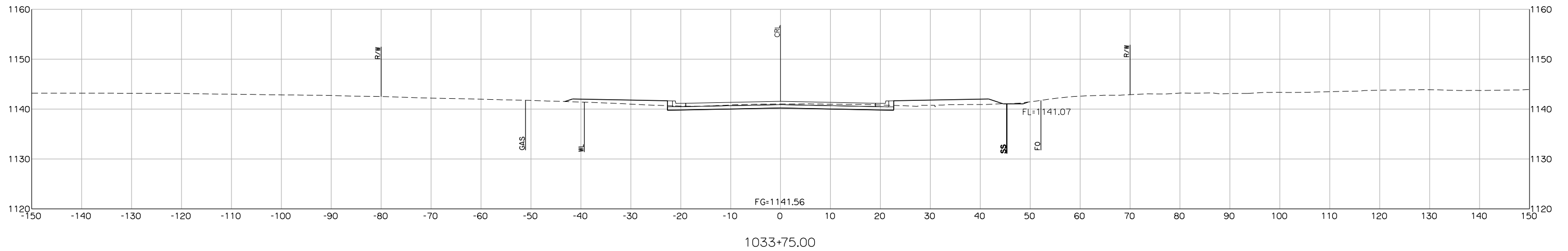
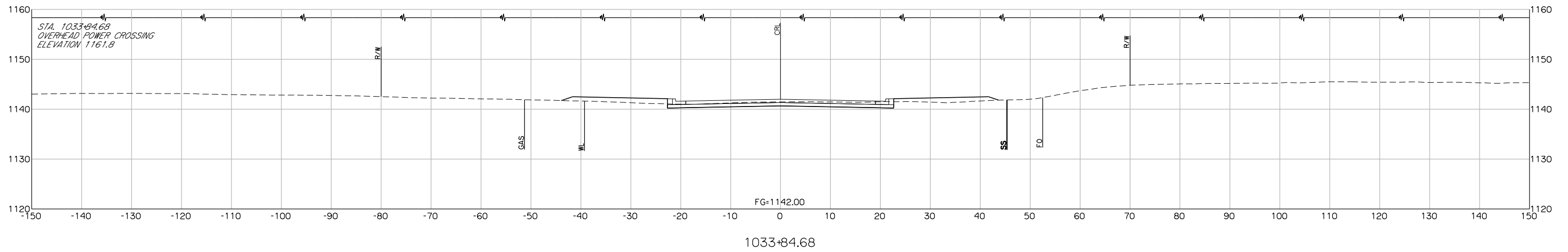
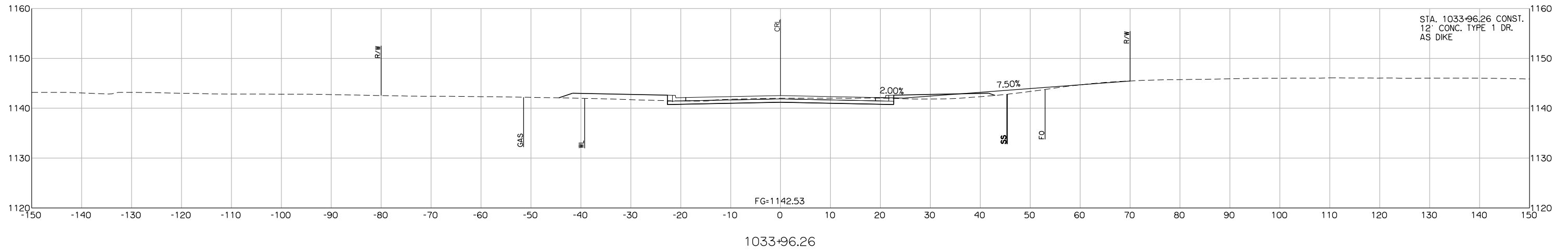

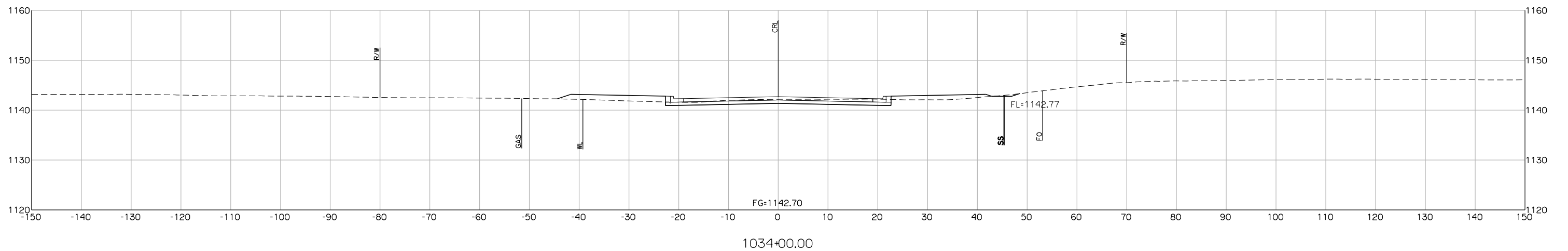
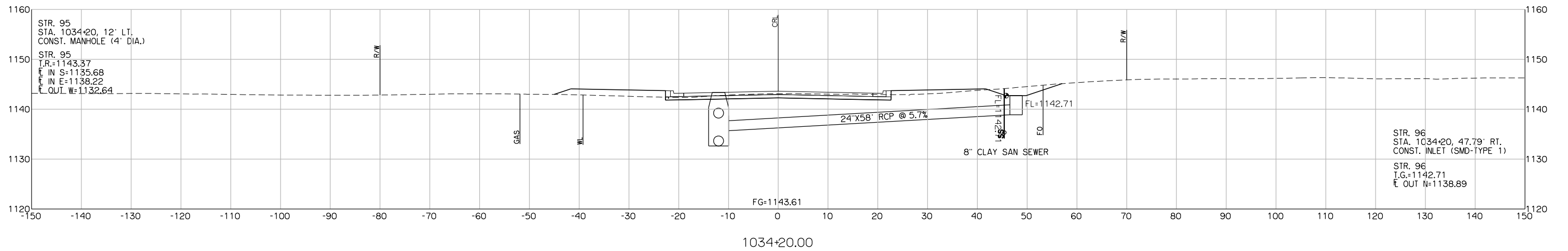
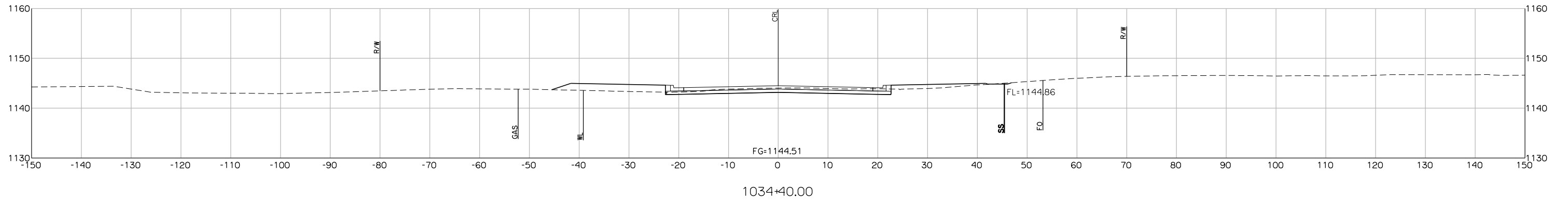

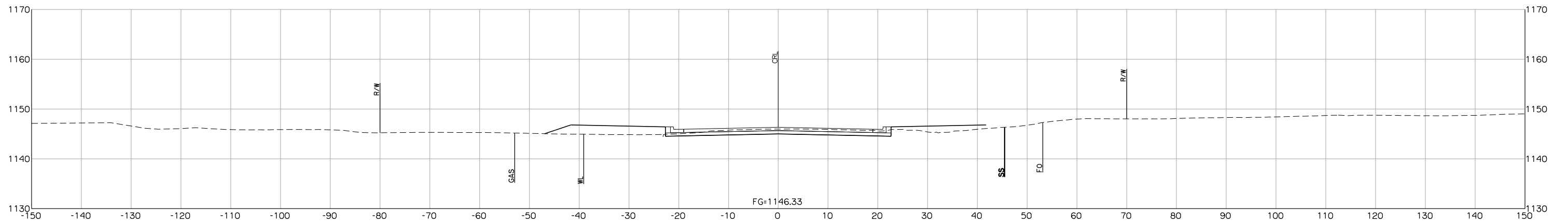

1034+80.00

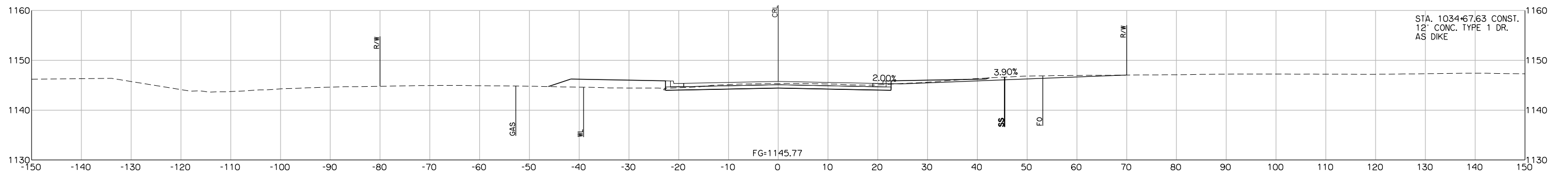

1034+67.63

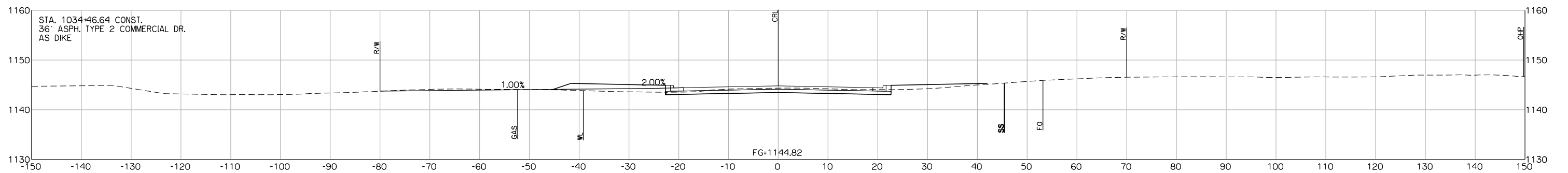

1034+46.64

