



UNDERGROUND GAS STORAGE REGULATORY CONSIDERATIONS

A Guide for State and Federal Regulatory Agencies



Underground Gas Storage Regulatory Considerations

A Guide for State and Federal Regulatory Agencies

States First Gas Storage Workgroup

Disclaimer: This is an informational document, and is not intended to offer recommended rules or regulations. States First recognizes that management and mitigation of the risks associated with underground natural gas storage are best considered at the state level with specific considerations at local, regional, or cross-state levels, due to significant variability in local geology and surface conditions (e.g., population, building conditions, infrastructure, critical facilities, etc.). Neither the Ground Water Protection Council, the Interstate Oil and Gas Compact Commission, (collectively the Group) nor any person acting on their behalf makes any warranty, express or implied; or assumes any legal liability or responsibility for the accuracy, completeness, or any third party's use or reliance on any information, apparatus, product, or process disclosed; or represents that its use would not infringe on privately owned rights. Reference herein to any specific commercial product, process, or service by trade name, trademark, manufacturer, or otherwise, does not constitute or imply its endorsement, recommendation, or favor by the Group nor any person acting on its behalf. The views and opinions of individual authors expressed herein do not necessarily reflect those of the Group.

Recommended citation: Ground Water Protection Council and Interstate Oil and Gas Compact Commission. *Underground Gas Storage Regulatory Considerations : A Guide for State and Federal Regulatory Agencies* . May, 2017. 122 pages.

Table of Contents

Preface.....	1
Executive Summary.....	2
Introduction to Underground Gas Storage.....	2
Regulatory Framework of Underground Gas Storage (Federal and State).....	2
Risk Management.....	3
State Permitting of Underground Gas Storage.....	3
Well Drilling, Construction, and Conversion.....	3
Well Integrity Testing.....	3
Reservoir Integrity.....	4
Injection and Withdrawal Well Operations and Maintenance.....	4
Monitoring and Observation Wells.....	5
Wellhead and Surface Facilities.....	5
Emergency Response Planning.....	5
Temporary Abandonment, Well Closure and Restoration.....	6
Chapter 1: Introduction to Underground Gas Storage.....	7
Chapter 2: Regulatory Framework of Underground Gas Storage (Federal and State).....	10
a. Federal.....	10
b. State.....	12
Chapter 3: Risk Management.....	13
Introduction.....	13
Major Issues and Concerns.....	13
Main Take-Aways.....	13
Risk Management.....	14
a. Plan Elements.....	14
b. Identification of Potential Threats and Hazards.....	14
c. Preventive and Mitigative Responses to Threats and Hazards.....	15
d. Approval and Certification Requirements.....	15
e. Updating Plans.....	16
Chapter 4: State Permitting of Underground Gas Storage.....	17
Introduction.....	17
Major Issues and Concerns.....	17
Main Take-Aways.....	18
State Permitting of Underground Gas Storage by Reservoir Type.....	18
a. Geologic Site Characterization General Comments.....	18
b. Engineering Review.....	23
c. Area of Review.....	25
d. Siting and Spacing Considerations.....	27
e. Operational Requirements Near Sensitive Areas.....	28
f. Drilling Through Storage Reservoirs by Type.....	28

Chapter 5: Well Drilling, Construction, and Conversion	30
Introduction.....	30
Major Issues and Concerns.....	30
Main Take-Aways.....	30
Well Drilling, Construction, and Conversion.....	31
a. Goals of Drilling, Cementing and Completion.....	32
b. Drilling Process for Porosity Storage (Depleted and Aquifer Storage Reservoirs)...	32
c. Casing Program Development for Porosity Storage.....	32
d. Wellhead Construction for Porosity Storage.....	33
e. Well Cementing and Evaluation for Porosity Storage.....	33
f. Well Completion Methodology for Porosity Storage.....	34
g. Drilling Wells for Bedded and Domal Salt Cavern Storage.....	34
h. Casing Program for Bedded and Domal Salt Cavern Storage.....	35
i. Wellhead Construction for Bedded and Domal Salt Cavern Storage.....	35
j. Well Cementing and Evaluation for Bedded and Domal Salt Cavern Storage.....	36
k. Well Completion Methodology for Bedded and Domal Salt Cavern Storage.....	36
l. Drilling Process for Wells in Hard Rock Cavern Storage.....	37
m. Casing Program for Mined-out Cavern Storage.....	38
n. Wellhead Construction.....	38
o. Well Cementing and Evaluation for Hard Rock Cavern Storage.....	39
p. Well Completion Methodology for Hard Rock Cavern Storage.....	39
q. Plugging and Abandonment of Shafts.....	40
Chapter 6: Well Integrity Testing	41
Introduction.....	41
Major Issues and Concerns.....	41
Main Take-Aways.....	41
Objectives, types and methods of mechanical integrity testing.....	41
a. Objectives of Integrity Testing.....	41
b. Types of Well Integrity.....	42
c. Well Integrity Testing Methods and Technologies.....	43
d. Internal Well Integrity.....	46
e. External Well Integrity.....	48
f. Evaluating Mechanical Integrity Testing.....	52
Chapter 7: Reservoir Integrity	53
Introduction.....	53
Major Issues and Concerns.....	53
Main Take-Aways.....	53
Reservoir Integrity.....	54
a. Relevance of Reservoir Integrity to Underground Gas Storage.....	54
b. Guidance from Existing Standards.....	57
c. Risks and Mitigation Strategies in Underground Facilities.....	58
d. Rock Mechanics Aspects of Geologic Storage.....	60
e. Pore Storage Considerations in Depleted Formations.....	62
f. Pore Storage Considerations in Aquifers.....	64
g. Salt Cavern Storage Considerations.....	66

Chapter 8: Injection and Withdrawal Well Operations and Maintenance.....	70
Introduction.....	70
Major Issues and Concerns.....	70
Main Take-Aways.....	70
Well Operation and Maintenance.....	71
a. Long Term Well Integrity.....	71
b. Periodic Well Integrity Testing.....	72
c. Periodic Wellhead Inspections.....	75
d. Periodic Wellsite Inspections.....	75
e. Maintenance Requirements and Schedules.....	76
f. Water Wells.....	76
g. Well Reporting and Compliance.....	76
h. Procedures, Training, and Record Retention.....	77
Chapter 9: Monitoring and Observation Wells.....	78
Introduction.....	78
Major Issues and Concerns.....	78
Main Take-Aways.....	78
Monitoring and Observation Wells.....	78
a. Reasons and Justification.....	78
b. Well Construction.....	79
c. Monitoring Type and Frequency.....	80
d. Reporting Requirements and Alarms.....	80
e. Observation Well Operations and Maintenance.....	80
Chapter 10: Wellhead and Surface Facilities.....	82
Introduction.....	82
Major Issues and Concerns.....	82
Main Take-Aways.....	82
Surface Facilities.....	82
a. Overview.....	82
b. Wellhead.....	83
c. Pipeline Isolation Valve / Equipment Between Wellhead and Hand-off to U.S. Department of Transportation Jurisdiction.....	89
d. Pressure Management/Monitoring.....	90
e. Surface Leak Detection.....	92
Chapter 11: Emergency Response Planning.....	98
Introduction.....	98
Main Issues and Concerns.....	98
Main Take-Aways.....	99
Emergency Response Program Organization.....	99
a. Purpose and Scope.....	99
b. Leadership, Commitment, and Policy.....	99
c. Response Team Organization.....	99
d. Roles and Responsibilities.....	100
e. Resources Allocation and Development.....	100
f. Communication Systems.....	100

Emergency Response Planning.....	100
a. Emergency Response Planning.....	101
b. Emergency Response Planning Implementation.....	101
c. Training and Education.....	102
d. Exercises, Program Maintenance, Improvement, and Update.....	103
Chapter 12: Temporary Abandonment, Well Closure, and Restoration.....	104
Introduction.....	104
Major Issues and Concerns.....	104
Main Take-Aways.....	104
Temporary Abandonment, Well Closure, and Restoration.....	104
a. Safety Considerations.....	104
b. Potential Considerations for Porosity Storage.....	105
(Depleted and Aquifer Storage Reservoirs)	
c. Temporary Abandonment Well Considerations for Porosity Storage.....	105
d. Plugging and Abandonment Well Considerations for Porosity Storage.....	105
e. Restoration of Site for Porosity Storage Wells.....	106
f. Potential Issues for Salt Cavern Storage Wells.....	106
g. Temporary Abandonment Well Considerations for Salt Cavern Storage.....	107
h. Plugging and Abandonment Well Considerations for Salt Cavern Storage.....	107
i. Restoration of Salt Cavern Storage Wells.....	108
j. Potential Considerations for Hard Rock Cavern Storage Wells.....	108
k. Temporary Abandonment Well Considerations for Hard Rock Cavern Storage.....	109
l. Plugging and Abandonment Well Considerations for Hard Rock Cavern Storage.....	109
m. Restoration of Hard Rock Cavern Wells.....	111
Appendix A: List of References.....	112
Appendix B: List of Acronyms.....	118
Appendix C: List of Terms.....	119
Acknowledgements.....	121

Preface

Underground storage of gas is a critical element in the U.S. energy supply and distribution system. It plays an essential role in maintaining the reliability of natural gas supplies and ensuring stable prices for consumers.

The first underground gas storage (UGS) (*Includes underground storage of natural gas and natural gas liquids unless otherwise noted) operation in the U.S. began in 1916 near Buffalo, New York. Today there are over 400 active UGS facilities in the U.S., operated by about 120 companies. Over 80 percent of the U.S. gas storage is in depleted oil or natural gas reservoirs. Most of the remaining storage is in non-potable aquifers or in salt caverns developed specifically for that purpose, with a few facilities utilizing mechanically mined caverns.

Most underground storage facilities have safe histories of operation; however, when an accident occurs, it can have dramatic impacts on public health and safety and the environment. Two of the most serious occurred at the Moss Bluff storage facility in Texas and the Yaggy storage field in Kansas. The Moss Bluff facility was a salt cavern storage operation. In August 2004, casing in one of the wells failed, resulting in a large release of gas and an uncontrolled fire lasting for more than six days. The Yaggy incident involved a wellbore failure which led to a series of gas explosions in Hutchinson, Kansas. The explosions and fire damaged 26 businesses and caused two deaths.

Most recently, there was a serious underground leak at the Aliso Canyon gas storage facility near Los Angeles, California. The leak began in October 2015 and continued for almost four months before it was controlled. It is characterized as the worst natural gas leak in U.S. history, and resulted in the evacuation of about 4,000 homes in the area. The incident has focused attention on the regulation of gas storage operations across the U.S. In response to that concern, states established a Natural Gas Storage Task Force under the auspices of the States First Initiative.

The States First Initiative is a state led program organized by the Interstate Oil and Gas Compact Commission (IOGCC) and the Ground Water Protection Council (GWPC). Its purpose is to facilitate multi-state collaboration and innovative regulatory solutions for states involved with oil and natural gas production and related issues.

This report is the principal work product of the Gas Storage Workgroup of the States First Initiative. The report was drafted by state regulators, with input and advice from experts in academia, industry, non-profit organizations, other state and federal agencies, and other interested parties. The report evaluates potential vulnerabilities at gas storage operations and identifies prospective regulatory responses for consideration by state and federal agencies. It is intended to serve as a resource for regulatory agencies, and not to advocate for specific regulatory actions.

Executive Summary

Introduction to UGS

This report addresses underground storage of both natural gas and liquid petroleum gas (LPG). Natural gas is composed primarily of methane but may have minor amounts of other hydrocarbon gases and other gases. LPG is a product of gas processing and petroleum refining; it is composed primarily of propane, butane, and related hydrocarbons that are gaseous at standard temperature and pressure but are stored and transported in a liquid state under pressure. In this report “gas”, “gas storage”, and UGS refer to both natural gas and LPG unless the wording or context denotes only natural gas.

The primary purpose of UGS is to provide a buffer between a relatively constant supply and variable demand for natural gas and LPG. UGS allows large supplies of gas to be stored during times of low demand, and withdrawn from storage when demand for natural gas is high, which reduces the need for larger transmission pipelines and allows for continuous supply of gas in the event of supply interruptions such as natural disasters, accidents, or acts of terror.

The need to store large volumes of natural gas to provide a leveling buffer between supply and demand has been recognized since natural gas transmission pipelines were initially being built in the late 1890s. Seeing the importance of a reliable supply of natural gas, the U.S. Geological Survey (USGS) recommended in 1909 that surplus natural gas be stored in underground reservoirs.

The natural gas industry relies on a complex network of transmission and distribution lines to provide the primary link from producing areas to end users; however, the storage of natural gas is an essential component of this system and is critical for maintaining its efficiency and reliability. One of the challenges with using gas is that it is more difficult to stockpile than other fuels, such as coal or oil. To manage this issue, gas is stored in underground formations that provide for the containment of large volumes of gas and quick withdrawal to meet the needs of end users.

Regulatory Framework of Underground Gas Storage (Federal and State)

Gas storage is regulated at both the federal and state levels by a combination of regulatory authorities. At the federal level the principal regulatory authority is the Federal Energy Regulatory Commission (FERC). However, FERC has a limited role in the actual management of facilities. Primary responsibility for gas storage facility safety resides with the Pipeline and Hazardous Materials Safety Agency (PHMSA) which is part of the U.S. Department of Transportation (USDOT). With respect to state regulation of gas storage there are a number of authorities which play varying roles. For example in most states the oil and gas regulatory agency has primary authority over permitting, operation, and closure of storage facilities while public utility commissions exercise authority over gas rates. However, in some states the utility regulatory authority has a greater role in actual facility functions.

With the adoption of the PHMSA Interim Federal Rule (IFR), the states and the federal government now may formally share authority over the nation’s 400 plus natural gas storage facilities provided states apply for and obtain certification from PHMSA to do so.

Risk Management

Risk can be defined as the probability of an activity having negative consequences. It is an inherent property of all human activity. While no activity is “risk free”, there are varying degrees of risk and the management of risk is a prime component of any gas storage project. The principal purpose of risk management is to identify, assess and take appropriate risk-reduction measures for threats and hazards associated with gas storage.

Risk management plans (RMPs) are developed by gas storage operators in anticipation of potential events. These plans are typically updated on a routine basis and are usually included in the application for a permit submitted to the state.

State Permitting of Underground Gas Storage

The permitting of gas storage facilities at the state level consists of administrative and technical reviews of an application submitted by a gas storage operator. The purpose of these reviews is to assure that the operation of the storage facility will be conducted in a manner that protects the environment and prevents the migration of gas out of the storage zone. The nature of the review depends upon several factors including the location of the facility, the depth to protected groundwater, the type of storage media (porosity or cavern), the location and condition of existing wells in the storage project area and the operation specifications of the particular storage project.

Well Drilling, Construction and Conversion

One of the principal components of any gas storage project is the wells that are used to emplace and withdraw gas into the storage zone (injection/withdrawal wells) and those that are used to monitor gas storage operations (monitoring wells). The drilling, construction, and conversion of injection/ withdrawal wells is typically authorized under the state oil and gas regulatory authority, which requires an operator to develop wells in a manner that prevents the migration of stored gas out of the storage zone and is protective of human health and the environment. While the drilling and construction of wells varies depending upon the type of storage zone to be utilized, in general, this is accomplished through the application of specific requirements on the operator. These requirements typically include the use of materials and methods such as the use of specific drilling fluids, use of blow out prevention equipment, placement of multiple casing strings, cementing of casing using the displacement method, and, where deemed necessary by the regulatory authority, equipping the well with tubing and packer. For further information about the use of multiple barriers please see the United States Department of Energy (USDOE) report. (1) One principal concern is the conversion of existing wells from oil or gas production to gas storage. Because these wells were not drilled or constructed specifically as gas storage wells, it is important to evaluate their capabilities for this use and to perform testing and, as needed, remedial construction to assure they can be safely operated in a gas storage regime where the well will be subjected to pressures and stresses not typically found in oil and gas production.

Well Integrity Testing

After a well has been drilled and constructed in accordance with regulatory requirements it is necessary to assure that the construction has been accomplished in a way that will prevent migration of gas out of the gas storage zone. This is called well integrity and is accomplished by subjecting the well to various tests that demonstrate both internal (casing, tubing and packer) integrity and external (cement) integrity. The principal test of internal integrity is the Standard Annulus Pressure Test (SAPT). It involves filling the

space between the tubing and the casing with a non-compressible fluid, placing the fluid under pressure for a pre-determined amount of time and evaluating changes in the pressure that might indicate a leak in the casing, tubing or packer. External mechanical integrity is often demonstrated by running a variety of tests which can demonstrate the quality of the cement bond between the casing and cement or demonstrate the lack of fluid or gas movement behind the casing. These tests can include Cement Bond Logs (CBLs), Temperature Logs, Noise Logs; Radioactive Tracer Surveys (RATs) and others.

The risks associated with performing tests should be considered when determining testing schedules, and the application or development of tests that require less invasive changes in the well operations should be encouraged.

Reservoir Integrity

In addition to the integrity of the well, the integrity of the reservoir or gas storage zone is of paramount importance to the safe operation of a gas storage project. Reservoir integrity refers to the geologic conditions for safe operation of UGS facilities beyond the wellbore. It is a function of the volume, operating pressure, and physical conditions of the gas storage reservoir or cavern. Likely risk areas for gas leakage are breaches of vertical and lateral confinement. An operator should consider the potential consequences of artificial penetrations of the gas storage reservoir or cavern, faults, fractures, confining zone/caprock sequence, and stratigraphy.

The integrity of gas storage reservoirs or zones relies primarily upon several factors such as the type of storage zone (porosity vs. cavern), the geologic framework (confining zones, structural closure, zone competence, pressure variables), and factors such as pressure maintenance, hydrologic conditions and others.

Injection and Withdrawal Well Operations and Maintenance

Gas storage wells and fields require proper operations, practices, and regular maintenance and assessments to ensure integrity and intended use throughout all stages of the facility's life – from permitting, start of initial testing, injection, and withdrawal from storage, through final plugging and abandonment.

The operation and maintenance of injection and withdrawal wells is highly dependent upon both the nature of the gas storage reservoir and the gas being stored. In porosity storage, gas storage wells often are converted former oil and natural gas producing wells that may be either existing or newly drilled and completed wells, properly tested to assure these dedicated storage wells will have extended lives. Long-term well integrity and functionality depend upon proper field and well operations and maintenance, including changes in the reservoir, fluids, rates, stimulation, remedial, offset, and surface conditions and parameters.

LPG salt cavern storage wells have significant differences in operation compared to natural gas storage; with both a brine side and a product side to the operation. These systems should be kept separate for safety and environmental considerations. Safety equipment, such as gas separators, directed to flares should be used to handle any LPG that enters the brine system. Gas detectors may also be deployed around the perimeter of the impoundment as an added safety feature. One should be concerned with the containment not only of the LPG, but also the brine.

Hard rock cavern storage relies on geomechanical stability that is addressed by the appropriate geomechanical analysis techniques. (2) The main issues and concerns with hard rock cavern storage include roof collapse, pillar collapse and surface subsidence.

Monitoring and Observation Wells

Gas storage projects require monitoring to assure that gas is not leaking from the gas storage reservoir or zone. This is accomplished through both surface and subsurface monitoring systems. With respect to subsurface systems the principal means of monitoring is through wells that are specifically drilled and constructed so that they can be used to assess the movement of gas within and outside of the reservoir or zone. These wells can be utilized to establish baseline conditions and allow for gas, pressure, and liquid monitoring of conditions and changes. They are typically drilled into formations that have relatively high permeability and porosity so that the movement of gas within the formation will reach the monitoring well and provide an early alert that gas has migrated outside of the storage zone. Monitoring or observation wells being considered for placement directly into the geologic formation(s) utilized for gas storage can be limited to the buffer zone (which is established outside of the delineated gas storage field) and can potentially detect additional pathways of gas migration out of the gas storage reservoir within the storage field. The use of and need for observation wells may be determined as part of the risk assessment for each new gas storage project.

Wellhead and Surface Facilities

In addition to the wells used to inject and withdraw gas from the storage zone there are a number of surface facilities related to gas storage operations. This guide deals exclusively with surface facilities between the well and the first isolation valve beyond the wellhead.

The wellhead is a critical surface facility component. It consists of a series of fittings, valves, and flanges often referred to as the “christmas tree”. The wellhead is essentially a well control mechanism that can be used to shut-in the well, to provide access points to the well itself, to be used to monitor well pressure, and to provide the piping that transports gas into the gathering system.

In addition to well and piping related equipment, gas storage facilities typically utilize equipment designed to detect surface leaks of gas. This includes systems such as infrared cameras and flame ionizations gas detectors that can be manually operated or automated. Surface leak detection equipment is designed to provide the operator with a warning in the event of gas leakage to the atmosphere.

Emergency Response Planning

Unlike risk management planning that is designed to evaluate the potential for failure, emergency response plans (ERPs) are designed to lay out the actions to be taken should a failure actually occur. ERPs may be created for foreseeable emergencies such as unintended releases of fluids, unexpected failure of critical equipment, natural disasters, damage to the facility that impedes facility operations, hazardous material and other releases, gas leaks from wells and pipelines, fire and explosions, well blow-outs, emergencies during routine well operations, medical emergencies, or manmade emergencies.

At a minimum, ERPs should be written to include detailed descriptions of the equipment, procedures, training, equipment testing, roles and responsibilities of all required responders, and supporting plan execution. ERPs should address internal and external communication protocols, including emergency contact information and procedures for notification. ERPs should include procedures for all major facility components, including wells, for all identified emergencies.

Temporary Abandonment, Well Closure, and Restoration

As with most human activities there may come a time when the operations of gas storage wells may need to be suspended temporarily or ceased permanently. The process of temporarily suspending the operation of gas storage wells is typically referred to as “temporary abandonment”. This process differs from mere shut down of a well in that it is governed by a regulatory process that includes notifications to the regulatory agency and in some cases the application of specific physical tests or well management techniques.

Unlike temporary abandonment, well closure involves changing the status of a well permanently by either plugging the well or applying other abandonment requirements as appropriate for the type of storage zone. In the event a well is permanently plugged this is typically accomplished through the placement of mechanical and/ or cement plugs at pre-defined intervals in the well to assure that gas or other fluids will not migrate through the plugged well. In some types of storage zones, such as in bedded salt caverns, wells may sometimes be left unplugged so that they can be used to monitor the conditions of the cavern over time.

The restoration of a gas storage facility site often includes the removal of surface equipment, grading of sites, and remediation of the surface to as near pre-storage condition as required by regulatory authorities. Removal of pipes, wellheads, tanks, gas processing equipment, fluid storage excavations, treatment equipment and all other surface facilities typically only occurs when the last storage well in the project is officially abandoned.

Chapter 1

Introduction to Underground Gas Storage

The U.S. economy relies upon an uninterrupted supply of energy. This energy is supplied by a variety of sources such as crude oil, natural gas, wind, solar, nuclear and coal. Over time, natural gas has become a vital component of the U.S. energy supply, currently comprising 29 percent of the total. In addition, natural gas is playing an ever-increasing role in meeting the nation's electricity demands. (3) The demand for natural gas is spread across numerous sectors of the U.S. economy and natural gas serves as an important energy source for industrial, commercial, and electrical generation sectors and also plays a vital role in residential heating.

The key advantages to natural gas keep an energy source are that it is clean burning, cost effective, and domestically abundant. Compared to other fossil fuels, natural gas is a cleaner-burning fuel with low air emissions, making it a popular choice for power companies seeking to comply with increasingly strict air emission standards. Additionally, over 95 percent of the natural gas consumed in the U.S. is produced domestically, resulting in a low-cost, stable supply that is not dependent on foreign sources that may be subject to potential instability caused by political stresses.

The natural gas industry relies on a complex network of transmission and distribution lines to provide the primary link from producing areas to end users. The storage of natural gas is an essential component of this system and is critical for maintaining its efficiency and reliability. One of the challenges with using natural gas is that it is more difficult to stockpile than other fuels, such as coal or oil. To manage this issue, natural gas is stored in underground formations that allow for the containment of large volumes of natural gas and quick withdrawal to meet the needs of end user.

As demand for natural gas has increased over the years, the importance of underground natural gas storage to the gas delivery network has increased proportionally. As UGS regulations and demand have evolved, operations have also changed and have allowed natural gas storage to maintain its essential role in ensuring the safe and reliable supply of natural gas to the U.S.

The need to store large volumes of natural gas to provide a leveling buffer between supply and demand has been recognized since natural gas transmission pipelines were initially being built in the late 1890s. Seeing the importance of a reliable supply of natural gas, the USGS recommended in 1909 that surplus natural gas be stored in underground reservoirs. (4)

The first underground natural gas storage project was in 1915 in a gas field in Ontario, Canada. The following year, the first underground natural gas storage project was initiated in the U.S. in a depleted gas field to serve peak demands for the City of Buffalo, New York. (5) (4) This storage field is still in operation and is the longest operating underground storage project in the world. (6) As demand for natural gas continued to grow, there was an associated increase in natural gas storage capacity, and by the 1930s, there were nine underground natural gas storage projects located across six states. (7) See the underground natural gas storage timeline in Figure 1-1.

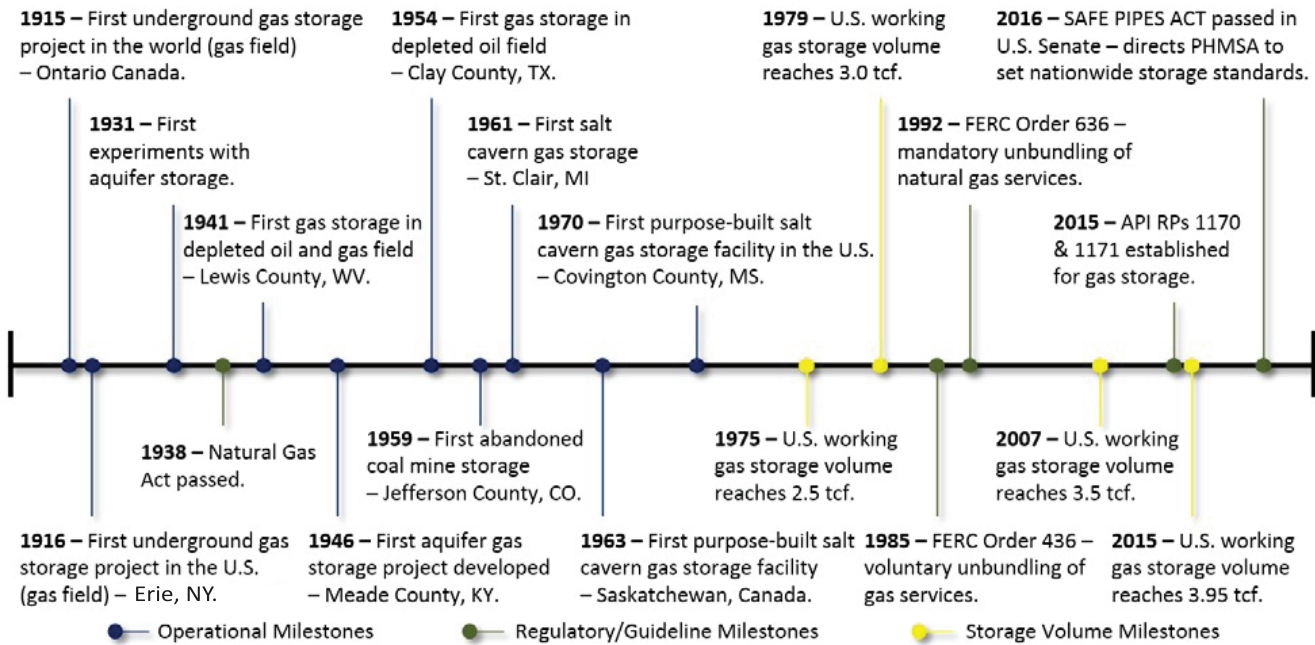

Figure 1-1 Underground Gas Storage Timeline

Until the 1930s, underground natural gas storage in the U.S. had generally been conducted in depleted gas reservoirs; however, with the U.S.'s continued reliance on natural gas, there was an associated need for additional storage capacity throughout the nation, which necessitated additional types of gas storage be used where depleted oil or gas fields were not available. To meet this need, experiments began with underground natural gas storage in different types of storage structures, including depleted oil and gas fields and aquifers. Expanding on the use of depleted hydrocarbon reservoirs for gas storage, the first gas storage project in a depleted oil and gas field was conducted in 1941 in West Virginia and the first storage in a depleted oil field was completed in 1954 in Texas. Early gas storage projects in oil fields were initially conducted to enhance oil recovery but the fields were converted to gas storage once the oil resources were depleted. The presence of oil in the storage reservoirs led to several complications, including enrichment of the gas and oil condensing out of the gas once it entered the pipeline, along with difficulties in assessing gas volumes in the reservoir due to large amounts of gas going into solution with the oil. (13) Since not all regions of the U.S. have adequate depleted oil and gas fields available, natural gas transmission operators began looking at aquifers as a storage option. The first experiments with gas storage in water-bearing formations began in 1931 and the first successful storage project in an aquifer was completed in Kentucky in 1946. (6)

The first usage of a salt cavern for gas storage was in 1961 using an abandoned salt cavern from the Morton Salt Company. Subsequent salt cavern storage facilities were constructed in salt deposits that had been mined for their salt for use in the chemical industry. The first salt cavern designed specifically for use as a gas storage facility was in Saskatchewan, Canada, in 1963, followed by the first “purpose-built” gas storage salt cavern in the U.S. constructed in Mississippi in 1970. (6)

Additionally, storage has historically been conducted in abandoned mines, although none are currently in operation in the U.S. The first abandoned mine used for gas storage was conducted in Jefferson County, Colorado, in an abandoned coal mine. This abandoned mine storage was in operation until 2003 when the city of Aurora, Colorado, bought the mine for use as a subsurface water reservoir. (8)

Over the years, various factors have resulted in a continued increase in the demand for natural gas storage capacity, which has risen 12 percent between 2000 and 2015. (17) As of December 2015, according to the U.S. Energy Information Administration (U.S. EIA), the U.S. has 415 active underground natural gas storage projects, which is more than any other country in the world. (3)

The primary purpose of UGS is to provide a buffer between a relatively constant supply and a variable demand for gas. UGS allows large supplies of natural gas to be stored during times of low demand, and withdrawn from storage when demand for natural gas is high, which reduces the need for larger transmission pipelines and allows for continuous supply of gas in the event of supply interruptions such as natural disaster, accidents, or acts of terror. This helps keep prices relatively stable through seasonal peaks in demand or other disruptions. Further, in a somewhat recent development, gas storage may be used by marketers for price hedging.

Underground natural gas storage facilities play an essential role in reliable natural gas delivery and have been developed to ensure that natural gas is available for delivery to end-users on an as-needed basis. A lack of adequate gas storage could potentially result in the following:

- Black- or brown-outs during unexpectedly warm summers, resulting in a lack of electric power for items such as lights, electronics, and air conditioners;
- Lack of natural gas to heat homes in the winter;
- Lack of power generation for commercial and industrial sectors;
- Increased need for larger and more expensive transmission lines to transport the full volume of natural gas from the point of generation to the end-user; and
- Increased price volatility.

Chapter 2

Regulatory Framework of Underground Gas Storage

a. Federal

Until early 2017, federal regulation did not provide operational, safety, or environmental standards for the subsurface portions of underground natural gas storage facilities (wells, reservoirs, caverns) – the subject of this guidance document. The Natural Gas Pipeline Safety Act of 1968 has been found by a U.S. District Court to provide authority to the PHMSA over such facilities, but until 2017 the agency declined to develop regulations around them, stating in a 1997 Advisory Bulletin that operators should consult industry guidelines and state regulations on the subject.

Responding in part to the Aliso Canyon incident that began in October, 2015, the U. S. Congress passed The Protecting our Infrastructure of Pipelines and Enhancing Safety Act of 2016 (PIPES Act), which provided in Section 12 that PHMSA would develop safety standards relating to underground natural gas storage facilities, with a similar jurisdictional power-sharing arrangement with states to that described below for pipelines (i.e., states could certify with PHMSA to regulate intrastate facilities to PHMSA minimum safety standards plus state requirements that exceed those standards, but for interstate facilities, states may only certify to inspect such facilities while regulatory authority remains with PHMSA).

In December 2016, PHMSA introduced an Interim Final Rule (IFR) that incorporated two American Petroleum Institute (API) Recommended Practices (RP) (API RP 1170, “Design and Operation of Solution-mined Salt Caverns used for Natural Gas Storage,” issued in July 2015 (17), and API RP 1171, “Functional Integrity of Natural Gas Storage in Depleted Hydrocarbon Reservoirs and Aquifer Reservoirs,” issued in September 2015). (16)The IFR requires operators to comply with both the mandatory and non-mandatory provisions of the RP, with different sections required for new versus existing facilities; and for non-mandatory requirements, operators may decline to comply with justification to be reviewed by auditors. The IFR also provides for reporting requirements for facility operators.

The IFR is effective as of January 18, 2017. Operators have one year to comply with the IFR. PHMSA accepted comments on the IFR until February 17, 2017, but it is not required by law to respond or make adjustments to the IFR. PHMSA has signaled an intention to revise the gas storage rule over time.

Notwithstanding safety standards for the subsurface portions of gas storage facilities, the federal government has had longstanding general authority over gas pipelines and storage fields. FERC has jurisdiction over any underground natural gas storage project that is owned by an interstate pipeline and integrated into its system. In addition, independently operated storage project that offer storage services to interstate commerce, also fall under FERC’s jurisdiction. FERC, however, has a very limited role when it comes to the safety aspects of the facilities it regulates, whether such facilities are pipelines, underground storage reservoirs or caverns, or liquid natural gas import or export developments.

The Federal agency with safety primacy over gas storage and transportation is the USDOT. USDOT is mandated to provide pipeline safety under Title 49, U.S.C. Chapter 601. PHMSA’s Office of Pipeline Safety administers the national regulatory program to ensure the safe transportation of natural gas and other hazardous materials by pipeline. It develops safety regulations and other approaches to risk management that ensure safety in the design, construction, testing, operation, maintenance, and emergency response

of pipeline facilities. Many of the regulations are written as performance standards which set the level of safety to be attained and allow the pipeline operator to use various technologies to achieve safety.

PHMSA ensures that people and the environment are protected from the risk of pipeline incidents. This work is shared with state agency partners and others at the federal, state, and local level, as described below. Section 5(a) of the Natural Gas Pipeline Safety Act of 1968 provides that a state agency may assume all aspects of the safety program for intrastate facilities by adopting and enforcing the federal standards upon application to and approval from USDOT; while section 5(b) permits a state agency that does not qualify under section 5(a) to perform certain inspection and monitoring functions. A state may also act as USDOT's agent to inspect interstate facilities within its boundaries; however, USDOT is responsible for enforcement action. The majority of the states have either 5(a) certifications or 5(b) agreements, while nine states act as interstate agents. USDOT pipeline standards are published in Parts 190-199 of Title 49 of the Code of Federal Regulations (CFR). Part 192 of 49 CFR specifically addresses natural gas pipeline safety issues.

Under a Memorandum of Understanding (MOU) on Natural Gas Transportation Facilities dated January 15, 1993 between USDOT and FERC, USDOT has the exclusive authority to promulgate federal safety standards used in the transportation of natural gas. Project developers should attest that they will design, install, inspect, test, construct, operate, replace, and maintain the facility for which a certificate is requested in accordance with federal safety standards and plans for maintenance and inspection. Alternatively, the applicant must certify that it has been granted a waiver of the requirements of the safety standards by the USDOT in accordance with section 3(e) of the Natural Gas Pipeline Safety Act. FERC accepts this certification and does not impose additional safety standards other than the USDOT standards. If the Commission becomes aware of an existing or potential safety problem, there is a provision in the Memorandum to promptly alert USDOT. The MOU also provides for referring complaints and inquiries made by state and local governments and the general public involving safety matters related to pipeline under the Commission's jurisdiction.

FERC also participates as a member of USDOT's Technical Pipeline Safety Standards Committee which determines if proposed safety regulations are reasonable, feasible, and practicable. The pipeline and aboveground facilities associated with any FERC jurisdictional must be designed, constructed, operated, and maintained in accordance with USDOT Minimum Federal Safety Standards in the CFR section 49 CFR Part 192. The regulations are intended to ensure adequate protection for the public and to prevent natural gas facility accidents and failures. Part 192 specifies material selection and qualification, minimum design requirements, and protection from a variety of diverse threats including internal, external, and atmospheric corrosion.

In addition to the new requirements set out by the IFR, Part 192 sets out area classifications for gas storage and a transportation system based on population density in the vicinity of the system and specifies more rigorous safety requirements for populated areas. The class location unit is an area that extends 220 yards on either side of the centerline of any continuous one-mile length of pipeline. For storage projects this pipeline would be the "pipeline header" connecting the storage project to the interstate pipeline grid.

The four area classifications are defined as follows:

- Class 1 Location with 10 or fewer buildings intended for human occupancy;
- Class 2 Location with more than 10 but less than 46 buildings intended for human occupancy;
- Class 3 Location with 46 or more buildings intended for human occupancy or where the

- pipeline lies within 100 yards of any building, or small well-defined outside area occupied by 20 or more people on at least 5 days a week for 10 weeks in any 12-month period; and Class 4 Location where buildings with four or more stories aboveground are prevalent.

Class locations representing more populated areas require higher safety factors in pipeline design, testing, and operation. Pipe wall thickness and pipeline design pressures, hydrostatic test pressures, Maximum Allowable Operating Pressure (MAOP), inspection and testing of welds and frequency of pipeline patrols and leak surveys must also conform to higher standards in more populated areas. If a subsequent increase in population density adjacent to the right-of-way indicates a change in class location for the pipeline, FERC jurisdictional project sponsors would be required to reduce the MAOP or replace the affected segment of the pipeline header with piping of sufficient grade and wall thickness, if required to comply with USDOT code of regulations for the new class location.

b. State

States have regulated gas storage facilities since the beginning of the 20th century. Several states have dedicated regulatory frameworks for gas storage facilities (these are especially common in states with significant cavern storage capacity), but in the majority of states with oil and gas development, the states' core well integrity rules (concerning drilling, casing, cementing, and related topics) apply to gas storage facilities as well. States are increasingly considering the development of stand alone gas storage facility rules (hence the development of this report).

While many states have imposed their rules on intrastate and interstate facilities alike, a 2010 decision by the U.S. District Court for the District of Kansas (*Colorado Interstate Gas Company v. Wright et.al*, U.S. District Court, District of Kansas, April 13, 2010) found that Kansas's regulation of interstate facilities was pre-empted by federal legislation, even though no federal regulation of gas storage facilities existed at the time. While the decision was limited to Kansas, this court-created regulatory vacuum for interstate facilities was part of what prompted increased interest in federal regulation that ultimately led to the PHMSA IFR described in the previous section.

With the adoption of the PHMSA IFR, the states and the federal government now may formally share authority over the nation's 400 plus gas storage facilities provided states apply for and obtain certification from PHMSA to do so. For intrastate facilities, states will now be required to adopt the federal standards but may certify to act as PHMSA's agent and to impose its own rules that go beyond the federal standard. For interstate facilities, states may certify to inspect such facilities to PHMSA standards but may not conduct enforcement activities nor impose any additional rules on those facilities. These certification processes have not been developed as of this report's publication date.

Chapter 3

Risk Management

Introduction

Risk management is an imperative aspect of operating a gas storage project. A risk management plan (RMP) identifies all potential threats and hazards to well and reservoir integrity, as well as to human health, safety, property, natural resources, and the environment. The plan considers all phases of a gas storage project including, but not necessarily limited to, well drilling and rework, completion, injection and withdrawal operations, safety systems, well integrity testing, geological and other hazards, and monitoring. Risk management is conducted regardless of any statutory or regulatory requirement. Risk management addresses both generically-conceived potential risks and site-specific risks. Site- and project-specific planning enables development of risk control and response measures that are appropriate to each facility.

Risk management is a dynamic and ongoing process. Risk assessments and plans are reviewed and updated as necessary as changes occur or at a default frequency, or as determined by regulation. Risk management may include the reasonable tolerance of risk. Risk cannot be completely eliminated. Regulatory authorities may determine or approve levels or types of acceptable risk. Acceptable risk refers to the level of human, property or environmental impact that can be tolerated by individuals, companies, regulators, communities or governments and one for which no mitigation or other risk-reduction effort is made. Acceptable levels or types of risk likely will vary from facility to facility, dependent on state (e.g., specific laws and regulations), proximity of nearby populations, facilities and infrastructure, ecosystems etc., and the reasonably modeled events that might occur if an acceptable risk evolves into an occurrence (event).

Major Issues and Concerns

Risk management is an important element in the operations of storage projects. The major issues and concerns for risk management include:

- Potential threats and hazards to human health, safety, and the environment;
- Assessment and appropriate ranking of potential threats and hazards to human health, safety, and the environment;
- Potential threats and hazards to a storage facility that can affect well and reservoir integrity and performance;
- Preventive and mitigating (P&M) measures to monitor and/or reduce risk; and
- Contingency provisions (e.g., emergency response plans (ERPs); see Chapter 11 of this document) to guide the response to unplanned or emergency events.

Main Take-Aways

- Risk management is undertaken to identify, assess and make appropriate risk-reduction measures for threats and hazards associated with gas storage.
- Risk management is a dynamic, ongoing process that requires periodic updates to the plans.

Risk Management

a. Plan Elements

Risk management has many elements. Many of these elements are discussed in later sections of this guidance and only briefly discussed in this chapter. Elements of gas storage risk management include:

- i. Well work such as drilling, completion, workover, and conversion;
- ii. Geological characterization of the storage reservoir or salt body;
- iii. Well and reservoir integrity monitoring;
- iv. Critical above-ground systems; and
- v. Monitoring and observation wells.

Risk management should be considered during well and reservoir planning, construction, modification and maintenance. Gas storage operators should consider these factors in combination with local geological characteristics, the type of storage operation contemplated, and gas product(s) to be stored. Risk management and mitigation may affect selection, monitoring, and repair/replacement of casing, tubing, packers, various downhole equipment, and also wellhead components. Maintaining well integrity and other aspects of a storage facility is the goal of risk management.

Conversion of existing depleted oil and gas wells that were designed for the production of oil and natural gas is the most common type of development for gas storage facilities. Prior to converting an existing oil and gas well for use in gas storage, operators should conduct a series of tests to verify both internal and external mechanical integrity of a well.

Gas storage operations should never be conducted at pressures exceeding either the as-new design parameters (e.g., strengths) of a well or the strengths as conservatively recalculated following a thorough evaluation of a well's current condition (e.g. corrosion or degradation of casing; modern evaluation of cement outside pipe; etc.). Risk management includes both continuous and periodic monitoring of pressures, casing thicknesses, and other properties within wells and above ground conveyance and processing equipment. It also includes installation, maintenance, and testing of safety systems. Relevant safety systems include both monitoring systems such as Supervisory Control and Data Acquisition system (SCADA) and mechanical or other systems that may physically prevent a fluid or gas pathway.

b. Identification of Potential Threats and Hazards

Identifying and understanding threats and hazards to gas storage operations is requisite to determining and prioritizing risks and mitigative measures. (10) API RP 1171 lists common threats and hazards for safe storage of gas in reservoirs. API RP 1171 groups risks along themes of well integrity, design, operation, maintenance activities, well intervention, third party damage, outside forces/natural causes, geologic uncertainty, and reservoir fluid incompatibility. (10) Table 1 in API RP 1171 separates these risks into categories to account for threats to storage wells, reservoirs, and surface facilities. (10)

Risk assessment can be performed in various ways. Gas storage operators should utilize an appropriate risk assessment method to “identify potential threats and hazards to a storage facility; evaluate likelihood of events and consequences related to the events; determine risk ranking to develop preventive and mitigating measures to monitor and/or reduce risk; document risk evaluation and decision basis for P&M measures; provide for data feedback and validation; and review and update risk assessments to update information and evaluate risk management effectiveness.” (10) P&M measures may not be necessary for all identifiable risks and threats. (2)

The IOGCC document on storage in hard rock caverns lists various factors that should be included in a Process Hazard Analysis (PHA) for storage in hard rock caverns. The document also recommends that personnel performing a PHA for gas storage have engineering and cavern operation experience and knowledge of the specific PHA being utilized. (2) Identification of threats or hazards to salt cavern storage operations should consider general safety, potential loss of product, subsidence effects, and possible environmental impacts with specific regard to potential interactions with abandoned wells within ¼ mile of the cavern or the potential impact on other mining operations in the area. (11)

c. Preventive and Mitigative Responses to Threats and Hazards

API RP 1171 defines preventive measures for reservoir storage as those actions reducing the likelihood of risks to storage facilities and mitigative measures for reservoir storage as those actions reducing the consequences of threats to storage facilities. (10) Some examples of these actions are delineated in Table 2 in API RP 1171 by categories such as wells, reservoir, or surface, and the potential threats and mitigative or preventive measures commonly employed by storage operators. (10)

Some practices should be implemented regardless of storage medium. These practices include regular inspections and testing of instrumentation, valves, pumps, emergency equipment, control systems, shut-down valves, wellheads, and associated pressure monitoring systems. (2) Additionally, caverns, whether in hard rock or salt, and well casings should be tested prior to starting storage operations and regularly after that by an approved method. (2) Subsidence is a risk of cavern storage and such gas storage should include a program to monitor for subsidence. (2) Appropriate security should be in place at any gas storage facility with additional safety and security measures typically necessary during extensive well work. (2)

Cavern gas storage operators should consider the potential for each subsurface activity to adversely impact cavern and facility integrity. (2) Such impacts may include potential loss of product, subsidence effects, and possible environmental impacts with specificity concerning the potential for interaction with activity, current or future, which could have a significant impact on the water table level and allow for gas migration, or other aspects of safe and prudent operation. (2) Wells with long design lives should be constructed to monitor groundwater depth and/or chemistry in the vicinity of storage cavern(s). (2) Cavern storage facilities should be equipped with fail-safe devices which automatically operate in the event of an unauthorized or unsafe condition or status of the facility or in case of other emergency. (2)

d. Approval and Certification Requirements

Gas storage operators should appoint a multi-disciplinary evaluation team, with engineering and geological expertise to institute and conduct reviews of RMPs. (2) Prior to approving or certifying RMPs, regulators may consider using As Low as Reasonably Practical (ALARP) principles in their review of the plans to establish an acceptable level of risk. ALARP is similar to a cost benefit analysis, but takes other components into consideration. (12) ALARP establishes an area for the storage operator to work within different risk thresholds. The thresholds consist of an upper limit that is intolerable and a lower limit

that is broadly acceptable. At some point, the money spent by the storage operator to mitigate a risk may be grossly disproportionate to the associated reduction in risk or the risk has been reduced below the lower threshold where it is classified as broadly acceptable. (12) Regulators should assess whether further mitigation steps justify the costs which will be passed onto the users, and operators must evaluate the conditions surrounding their storage project to react as necessary to keep risk at an acceptable level. (12)

e. Updating Plans

Risk management is an ongoing and dynamic process. Risk assessment and management should be periodically (and additionally as prudent) reviewed and updated process. (10) Operators of cavern gas storage should use a team with appropriate expertise to write and review/update risk assessments and RMPs to verify they correspond to current conditions. (2) The functional integrity of storage operation is the underlying purpose of risk monitoring and management and should include continual review and improvement cycles in risk management activities. (10) Reviews of RMPs should be performed on a basis that is short enough to account for recent changes but long enough to provide useful data to storage operators. (10)

Chapter 4

State Permitting of Underground Gas Storage

Introduction

The permitting of gas storage facilities at the state level consists of administrative and technical reviews of an application submitted by a gas storage operator. The purpose of these reviews is to assure that the construction and operation of the storage facility will be conducted in a manner that protects the environment and prevents the migration of gas out of the storage zone. The nature of the review depends upon several factors, including the location of the facility, the depth to protected groundwater, the type of storage media (porosity or cavern), the location and condition of existing wells in the storage project area and the operation specifications of the particular storage project.

Major Issues and Concerns

The main technical goals of the UGS permitting process are two-fold. First, the applicant must demonstrate that the proposed storage zone, whether a depleted reservoir, aquifer, or salt cavern has the geological and geomechanical properties that render it suitable for secure gas storage over the life of the facility. Gas storage must be confined to the defined storage reservoir or cavern. Second, the applicant must demonstrate the storage operations will not endanger groundwater resources, public safety, human health, or the environment. Groundwater protection is accomplished by both selecting a suitable storage zone and also via suitable well design, construction, and subsequent facility operation. While the operator of a proposed gas storage project should perform initial site screening on its own and only propose what it views as suitable projects to the regulatory authority, the permitting process is the best opportunity for the regulatory authority to eliminate what it views as any unsuitable storage proposals or components of a proposal. The regulator's application review efforts should ensure that any storage project is properly sited and designed to be protective of public safety, natural resources, human health, and the environment.

The nature of gas storage, in any setting, will place large volumes of gas in underground formations. Ensuring this pressurized gas, stored in formations or caverns, does not have avenues for migration is the focus of effective permit application review.

The construction of new gas storage fields is a major capital investment for any company, and will involve many levels of study and review to determine if the site is appropriate for UGS. It is in an applicant's interest to have as much information as possible about a location for a storage field before ultimately pursuing a permit to operate the storage field. Permitting of federally regulated, interstate natural gas facilities will have a mandated permitting process regulated by FERC before receiving any required FERC certificate. Features of the FERC application process will be useful to the state regulator in considering its permit requirements.

The permitting of intrastate facilities, which are not regulated by FERC, will most likely have more burden of oversight placed on the state regulators. Many elements of a FERC approved facility should also be considered in state permitting. An equivalent of protection should be maintained in intrastate facilities as in federally regulated interstate facilities.

Main Take-Aways

- The regulatory review of a permit application for gas storage should focus on evaluating the geological and geomechanical properties of the proposed location, proposed well construction, previous oil or gas activity in the surrounding vicinity, and the ability of the project to be protective of public safety, natural resources, human health and the environment.
- While the main reservoirs used for UGS are either porous media or caverns, the focus of the regulatory review remains the same.
- On-site inspections by regulators are a vital part of the permitting review process. Inspections allow for the verification of all reported and expected site conditions.
- The three main portions of a technical permitting review are focused on geologic review, engineering controls, and the AOR.

State Permitting of Underground Gas Storage by Reservoir Type

a. Geologic Site Characterization General Comments

Geologic site characterization should be required prior to the development or expansion of an underground storage facility. This assessment should be done in conjunction with and coordinated with engineering studies. For existing facilities, the site assessment should be periodically updated during the life of the project as new data becomes available or if there are operational or geologic risk concerns.

The site characterization provides the basis for a practical understanding of the site-specific geology using maps and cross-sections constructed from available data such as well logs, cores, geophysical surveys, and historical records. The analysis of these data provides the geologic basis for feasibility, design, permitting, construction, optimization, and management of a storage asset. It also provides the basis to delineate and recognize geologic features that could potentially compromise the integrity of or be problematic for storage operations.

Creating space, storing and cycling product underground in geologic formations (salt caverns or porous media) creates a potentially dynamic situation in the rock mass that will be altered (i.e. stress, pressure, fluid contacts, etc.) from pre-storage conditions. The extent and impact of these changes need to be understood for the prudent design and operation of storage facilities as these altered conditions can impact technical feasibility, permitting, operations, and assessment of the geologic risk.

The ability to understand the geology in the subsurface will depend upon the availability, quality, quantity, distribution and type of data available. One aspect of a site characterization is to identify data gaps and make recommendations on where additional information is required. This may require the acquisition of additional data such as core data and testing, additional test wells, and well testing or geophysical surveys, depending upon the type of information required. Uncertainty in the geologic model can equate to some level of geologic risk. There will always be an element of geologic risk associated with subsurface work because of the inability to resolve, characterize, or have sufficient understanding of all of the details of the real world geology and potential risk features associated with a particular site. Therefore, an operator should continue to acquire, study, and maintain subsurface data throughout the life of a storage project. Maintaining and updating the geologic database and level of geologic understanding during the lifetime of a facility will allow for improved geologic risk management and mitigation capability.

Geologic maps are not the end product but are generated to provide the basis to analyze and communicate subsurface geologic information. It should also be noted that the geologic maps are an interpretation,

not necessarily the entire answer. The localized geologic interpretation should be consistent with and fit within the context of the surrounding sub regional geologic setting. It should also be consistent with not only the geologic data but also with observations from engineering data, well tests, and operational performance of the wells within the field. The interpretation should be updated and refined during the life of the storage asset as new information becomes available.

Additional information regarding geologic site characterization for underground storage can be found in API RP 1170 and API RP 1171. While these documents were written specifically for gas storage in salt and porous media respectively, the concepts regarding geologic characterization can be applied to underground storage in general. Additional information can be found in API RP 1114 E2 regarding liquid product storage caverns. (13)

i. Geologic Site Characterization for Porous Media

Gas can be stored in depleted oil and gas fields and aquifers. Although the focus may vary, the geologic methodology is basically the same for gas storage in depleted oil and gas fields and aquifers except that depleted oil and gas fields have demonstrated that they can trap gas of a specific volume over a period of time and they are generally associated with more well data and have a production history. New aquifer storage fields are potentially less well understood and may require more extensive exploration programs and testing prior to the beginning of storage operations to develop sufficient understanding to demonstrate that they are suitable candidates to store gas.

It should be noted that every reservoir site is geologically unique depending upon local stratigraphy, reservoir properties, depositional environment and deformational history. The geologic assessment of an underground storage field in porous media differs from that typically performed for oil and gas development in two fundamental ways. First, the reservoir and its sealing capabilities may have been altered by compaction or damage created by previous fluid extraction (hydrocarbons and formation water) due to grain repacking of partially fluid-supported sediments, altered pressure conditions, or migrating fluid contacts. Second, cycling gas in a porous reservoir creates a dynamic system involving pressure differentials and multi-phase fluid interactions that will often be in flux depending upon how and how often the reservoir is cycled. It is important that reservoir boundaries and potential migration paths are identified and product containment is demonstrated under the proposed operating conditions of the storage facility. The potential impact of such changes should be addressed by geologic, geomechanical and reservoir engineering assessments.

The objective of the site characterization is to evaluate the geologic setting to determine if a specified volume of gas can be safely contained in a predetermined location, sufficiently isolated from the Underground Source of Drinking Water (USDW) or other protected groundwater, and be cycled and recoverable in an economic and prudent fashion.

The geologic site evaluation of a porous reservoir should include but is not limited to an analysis of the following:

- ii. Field geometry – areal extent (lateral boundaries), size, structural configuration
 - 1. Reservoir characteristics – lithology, porosity, permeability, capillary pressure, pore throat size, thickness, depositional environment, reservoir /salt anisotropy and heterogeneity, effective vs. non-effective reservoir, faulting, reservoir

- 2. compartmentalization, current and historical fluid contacts, geomechanical properties, fluid saturation, discovery pressure for depleted field, and others;
- 3. Type and strength of reservoir drive (water drive, depletion drive, etc.);
- 4. Top seal/caprock – thickness, lithology, geomechanical strength properties, permeability, porosity, capillary pressure, and others;
- 5. Trapping mechanisms – top seal/caprock, structural closure, faulting, stratigraphic pinchout, gas/hydrocarbon/water contacts, spill points;
- 6. Base of USDW or other protected groundwater - isolation distance and permeability/porosity of intervening rock;
- 7. Hydrocarbon production or injection wells – maintain sufficient isolation from existing hydrocarbon production, and injection wells, including disposal wells;
- 8. Potential geologic risk elements (see Chapters 8 and 9 – for more detail) include but are not limited to:
 - a) migration pathways to the surface via faults or boreholes;
 - b) juxtaposition or potential connection of storage reservoir with other permeable units via scouring, faulting, unconformities and stray sand development, etc.;
 - c) fault compartmentalization;
 - d) spill points;
 - e) delta pressuring;
 - f) compromised caprock/top seal; and
 - g) interference with injection or hydrocarbon production;
- 9. Proximity to sensitive areas: Design for the protection of public safety, human health and the environment is of paramount importance during the storage field design process. This includes a review of safeguards to surrounding culture, surface water and groundwaters. The operator may also perform an environmental impact survey prior to commencing any drilling or facility construction. (10)
- 10. Setback requirements (10): Operators are encouraged to work with applicable land use authorities and landowners to ensure proper setbacks from the facility are applied;

iii. Siting and spacing considerations:

- 1. Geologic reservoir features
 - a) Porosity of formation;
 - b) Permeability of formation;
 - c) Depth of formation: A minimum depth is required. It may be hard to define an exact depth, but sufficient depth to ensure the zone is isolated and will not interact with surface features or people;
 - d) Confining zone: Formation must have impervious rock;
 - e) Lateral confinement: The storage horizon must have laterally containing features. Typically, they can be structural geologic features or other types of geological barriers that provide traps, pinch outs, adjoining salt dome deformation, igneous intrusions or others;
 - f) Define a buffer zone that reflects the geologic uncertainty of the particular field and risk;
 - g) Existing wells in depleted reservoir: Existing production wells in a potential storage field may be candidates for conversion to storage if their design and completion methods meet the storage standards. All existing production wells to be converted to storage should be thoroughly inspected

for well integrity, including downhole casing inspection logs, and pressure tested to confirm suitability for storage service. Any well that does not meet the storage standards should be either reworked to meet those standards or plugged and abandoned; and;

- h) Existing boreholes can be used as storage wells providing they meet regulatory requirements; and

iv. Operational requirements near sensitive areas:

1. The storage field design can include plans to monitor conditions as they pertain to well drilling and storage development for protecting the environment and health and safety of workers and the public. This includes the development of site-specific plans for known problems like geological and other potential hazards. (10)
2. Site specific requirements include (10):
 - a) Installation of protective equipment for site security and safety;
 - b) Development of storage well blowout contingency plans; and
 - c) Liaison with all pertinent local emergency personnel; and
 - d) Operators may also consider more frequent inspections or using leak detectors, downhole shut-off valves, or other safety devices in areas near populations or gathering spaces, or as determined by the site-specific risk assessment.

v. Geologic Site Characterization for Solution Mined Salt Cavern Storage

Both liquid and gaseous products can be stored in solution mined salt caverns in bedded, deformed or domal salt deposits. Gaseous products are also stored in mined salt caverns in bedded salt formations. Bedded salts are relatively undeformed salt deposits where the internal bedding is still largely preserved undisturbed. Domal salt generally has flowed several thousand feet vertically breaching the overlying strata. The internal bedding is often largely broken down into rafted blocks or stringers that parallel the flow banding. Hence, the geologic concerns for bedded salt differ somewhat from domal salt. Depending upon the amount and type of deformation, deformed salt will have various degrees of salt flow and preserved bedding.

Like porous media reservoirs it is important to evaluate salt cavern storage fields with regard to distance and isolation from USDW or other protected groundwater, existing or planned subsurface activity (wells, mines, other salt caverns, etc.) and reservoir quality (geomechanical properties and impurity content of the salt). For domal and highly deformed salts, a geologic assessment becomes more focused on resolving structural complexity, precisely identifying the edge of salt and resolving potentially problematic internal features such as anomalous zones, shear zones and faulting. It is important to remember that domal and deformed salt are potentially active geologic features whose current configuration and internal material properties are determined by initial stratigraphy, deformational history, dissolution, etc. Therefore, salt movement and dissolution can pose risk factors for drilling, well integrity and cavern integrity.

In most cases, as salt is the sealing media, there is no trapping mechanism other than the salt itself. Therefore, it is critical to demonstrate that there is sufficient good quality salt to develop the storage caverns, no geologic or man-made features that may provide potential weak zones or migrations paths, and that sufficient buffer exists from the edge of salt and the cavern, both laterally and vertically above and below the cavern. When assessing the distance to the edge of the salt, it is important to consider the density and definitiveness of the available data and the potential for salt quality to degrade towards the edge. Sufficient salt as determined by engineering studies should be maintained above the cavern to help support the overburden and caprock (if present) over the cavern roof.

Salt caverns are generally constructed in rock salt primarily composed of halite. The strength and creep properties of rock salt are influenced by its deformational history and impurity content.

Impurities and structurally stressed salt are generally considered to be anomalous and potentially problematic for salt cavern development. The presence of highly creep-prone or soluble salts such as Potassium-Magnesium potash salts can create the potential for irregular cavern geometries and high creep closure rates. High non-salt impurity content can lead to solution mining issues, and increased potential for roof falls. Sheared and faulted salt (often containing brine, gas or liquid hydrocarbons) can indicate differential salt movement, weak salt or porous salt that can impact cavern operations, and well and cavern integrity, or can contaminate the stored product.

In the case of bedded salts, the focus, geologically, is more on internal stratigraphy as the distribution of dirty (impure) salt or non-salt interbeds laterally and vertically will potentially limit the space for cavern development in good (pure) salt. Interbeds and dirty salt may be potentially problematic with regard to roof falls, or casing integrity, and they can create potential for irregular cavern shape and provide zones of potentially weak or permeable rock. The distribution, thickness, strength properties, fluid compatibility, and permeability of non-salt interbeds should be investigated. The contacts between non-salt interbeds and the salt can be planes of weakness and can result in unanticipated roof falls.

Differential salt movement between different salt spines, along faults or at the salt/country rock interface can be particularly problematic for well or cavern integrity.

The geologic site evaluation of salt caverns should include, but not be limited to, an analysis of the following:

1. Salt body geometry – areal extent and edge of salt, thickness, structural configuration;
2. Salt quality – salt quality, thickness, geomechanical properties, impurity content (lithology, amount, distribution), non-salt interbeds, anisotropy and heterogeneity, weak zones, highly soluble zones, creep prone zones, porous salt, and others;
3. Interbeds - mostly bedded salts and non-gulf coast domal or deformed salt structures. May be rafted apart where salt flow has occurred;
4. Caprock thickness and lithology (domal salt);
5. Base of USDW or other protected groundwater, - isolation distance and permeability/porosity of intervening rock;
6. Zones of active water flow or salt dissolution; and
7. Potential geologic risk elements, which may include but are not limited to:
 - a) Too close to edge of salt, edge of dome, stratigraphic pinchout, bounding faults, dissolution fronts, non-deposition;
 - b) Differential salt movement, shear zones and faults within the salt (boundary shear zones and edge zones);
 - c) Migration pathways to edge of salt via faults, boundary shear zones, weak salt, permeable salt;
 - d) Proximity to existing salt caverns (thin salt pillar), mines or wells drilled into salt; and
 - e) Caprock faulting and lost circulation zones – pose drilling risk and can compromise integrity of well casing and cementation.

vi. Geologic Site Characterization for Mined Cavern Storage

Liquid hydrocarbons and LPG may be stored in conventionally mined caverns in undeformed, impermeable non-porous rock such as hard shales, carbonates and crystalline igneous or metamorphic rock.

While abandoned mines have been used to store liquid product, it is generally accepted that purpose built mined caverns are less problematic and the better option. Natural gas storage is technically feasible in mined caverns; however, the increased mobility of natural gas would require some type of lining of the cavern walls to insure containment.

Like aquifer storage, mined caverns are generally located in areas of sparse well density and subsurface geologic data. Initial exploration can be done with core wells, hydrogeologic well testing and geophysical surveys. Unlike other types of storage projects, detailed information for mined caverns will be obtained during the construction of the cavern. This will include but not be limited to lithologic analysis, geo-mechanical testing, mapping the distribution and characteristics of fractures and faults, locating water seeps, etc. This geologic information should be used during construction to update the geologic model and modify the initial design as required.

The geologic site evaluation of mined caverns should include but not be limited to an analysis of the following:

1. Geometry of geologic formation of the cavern interval and surrounding rock: - thickness, areal extent, structural configuration, etc.
2. Lithology, rock matrix impermeability, petrophysical properties and strength properties of cavern interval and surrounding rock: - needed to demonstrate containment and structural integrity. The rock formation must be sufficiently impermeable to contain stored product while also stable enough to withstand the mining process and pressures associated with input and withdrawal cycles.
3. Distribution and characteristics of fractures and joint systems are critical: - possible product migration pathway and weak areas for cavern stability. These also may be a safety element during construction for possible rock falls during construction.
4. Isolation from USDW or other protected groundwater.
5. Seal (above and below): thickness, areal extent, structural configuration, lithology, impermeability.
6. Hydrogeological characteristics and distribution of hydraulic potential above, around, and below the cavern.

Potential geologic risks can include:

1. Migration of product through shaft, sump, boreholes, faults, voids, or through surrounding formation (i.e., more permeable, fractured, or zones with lower hydraulic potential, etc.).
2. Sinkhole formation
Long term monitoring of the hydraulic potential with monitoring wells is recommended since hydrogeological containment is a dynamic situation. Also injection wells may be needed to generate pressure curtains so that any fluid migration is in toward the cavern instead of out of the cavern.

b. Engineering Review

In addition to a geologic understanding of the proposed storage reservoir, the impact of installing and operating wells or caverns within the reservoir must also be considered. A detailed discussion of well drilling and operation can be found in Chapters 5 and 8, respectively. General topics to consider when evaluating a storage project from an engineering perspective follow:

i. Engineering Considerations for Porous Media

1. Engineering analyses including: (10)
 - a) An examination of well records to determine which current wells and abandoned wells have penetrated the formation (See Section c. of this chapter for more information on AOR);
 - b) A review of the wellbore mechanical integrity for suitability for the intended design and operation of the well and protection of the reservoir's integrity. This review applies to both new wells and existing wells that are proposed to be converted to storage service. This should include a review of the following:
 - 1) Casing materials;
 - 2) Casing configuration;
 - 3) Set depths;
 - 4) Cement;
 - 5) Placement depths;
 - 6) Completion records; and
 - 7) Geologic setting.
2. An analysis of abandoned and plugged wells to verify effectiveness of plugging methods and materials used as well as the placement of any plugs to prevent migration.
3. An analysis of the chemistry of reservoir fluids to determine characteristics and potential impacts on storage well drilling, completion and stimulation, and storage operations.

ii. Engineering Considerations for Solution Mined Caverns

When evaluating a salt formation for development of solution mined caverns, in addition to the issues discussed previously in the Engineering Considerations for Porous Media, the following issues specific to solution mined caverns should be considered:

1. The placement of the cavern from the edge of the salt
2. Faulting within the salt formation
3. Spacing between storage caverns
4. The proposed size and shape of the cavern, particularly as it relates to cavern stability
5. The maximum and minimum storage pressure within the cavern, with special attention to the fracture gradient of the salt and the minimum pressure needed to minimize salt creep

iii. Engineering Considerations for Mined Caverns

Development of a mined cavern will begin with a main shaft or well. The main shaft is large diameter and used for moving equipment and people into the cavern to begin the mining process. (14) This main entry point and some additional wells will be utilized for input and extraction of stored product. Wells proposed for storage operations should be permitted and constructed in accordance with existing oil and gas well construction standards. The number and distribution of wells for a storage project depends on the nature of the storage and deliverability desired. In addition to wells to be used for input and withdrawal,

the storage operator should be required to install and monitor an observation well or wells depending upon the size of the storage project and local conditions. See monitoring section for more detail on wells outside the cavern boundaries.

The mined cavern must undergo integrity testing prior to the commencement of storage operations. (2) To isolate potential avenues of migration, all penetrations into the cavern should be tested for mechanical integrity separately prior to testing the cavern as a whole. These individual well integrity tests can be performed using tubing and packer or during construction following the cementing of production casing. The storage operator and regulator should work together to agree upon criteria for successful integrity demonstration. Storage operations should not begin until a successful integrity test has been completed and approved by the regulator. In addition to cavern and well integrity, all conveyances should be individually tested prior to beginning service. This ensures integrity of pipelines, connections, valves, and any other potential sources migration or leakage.

c. Area of Review (AOR)

i. Size

1. An AOR will differ depending on type of storage facility. Reservoir and aquifer storage areas most likely have a wider buffer boundary that may be determined by the particulars of local geology, historic and current oil and gas and gas storage development and site specific storage area construction details. Solution mined cavern storage must also consider local geology and may have a smaller, better defined lateral extent.
2. The development of an AOR may consider whether it applies to the entire storage area and a buffer zone around the area, or to individual wells and buffer zones around them.
3. The size of the AOR of a new storage facility should be first determined by the geologic setting of the storage and regulatory requirements. Reservoir storage is often located in domed, anticlinal geologic features, stratigraphic or other geologic structural traps, with an impervious confining zone. Cavern storage AOR should also include an area overlying the storage horizon, considering all potential avenues of migration.
4. The lateral extent should include a horizontal zone of influence where the pressure of injected storage gas may:
 - a) have an effect on nearby production wells; or
 - b) exert pressure sufficient to force the migration of the gas or formation water into zones that present a hazard associated with loss of control of pressure gradient. These hazards could include; effects on USDWs or other protected groundwater, increased pressure in nearby wells, or the migration of gas to the surface, or other geologic horizons.
5. The AOR must also consider the lateral extent of geologic confining structure, to ensure gas does not leak out of the intended geologic structural or stratigraphic feature.

ii. Configuration

1. The configuration of the AOR for reservoir, aquifer, or cavern storage should consider:
 - a) Geologic setting of reservoir, aquifer, or cavern;
 - b) Prevailing directional dip of the formation(s);
 - c) Size, structure, history, evaluation, and depth of salt domes or beds;

- d) Potential sensitive surface features;
- e) Potential USDWs or other protected groundwater;
- f) Potential avenues of gas migration;
- g) History of subsurface drilling and underground activities (mining, solution mining, waste disposal); and
- h) Structural setting (faulting, folding, fracturing, and others).

iii. Elements of an AOR

1. The focus of an AOR must be to ensure that the storage area does not contain avenues of migration for fluid outside of the planned storage area, or if avenues of migration potentially exist that the development and operating plan have contingencies to investigate these avenues and address the risk if a migration avenue is subsequently found to exist.
 2. The AOR elements may share certain features as listed below, and any other local condition, particular to that region that may impact the integrity of the storage area, the integrity of particular wells or any surrounding area. Knowledge of local conditions; history, geologic setting, land use patterns, and demographics is vital to performing an adequate AOR.
 3. An AOR evaluation must contain a review of all available records for wells that were drilled in the AOR and buffer zone. This review should determine the location, depth, history, plugging history, cement integrity, and any other information necessary to ascertain the degree of risk to which existing wells pose a threat for fluid migration. Wells that are known to have penetrated, or were completed in the storage horizon, or are vertically proximate to the storage horizon should be of primary interest.
 4. A review of all plugged well records and their surface locations must be performed to determine if they were constructed and have been plugged in a manner that prevents a man-made pathway for the movement of gas or associated fluids from the storage zone. Particular interest must be focused on wells that penetrate into or through the proposed gas storage zone.
 5. The applicant may consider all the local history, to consider possible activity that was not permitted in the modern era, and for activities that may have not been adequately documented. Historical research and due diligence is of high importance. Historical research could include studies, papers, and reports on the geology of the field and any related engineering review or analysis.
 6. The applicant may also perform any practical physical reconnaissance that could reveal historical features of concern, such as aerial photographs, Light Detection and Ranging data, ground evaluation, seismic surveys, magnetic surveys, and resistivity, or conductivity surveys.
 7. Geologic factors such as faulting, folding, sinkholes, seeps, formation depth, permeability of surrounding rock, confining zone characteristics, and any other known features must be reviewed for all storage facilities for the potential to have adverse impacts to storage area.
 8. The collective evaluation of the AOR data must be a factor in determining the suitability of the area to be used as a storage facility.
 9. An AOR must include extensive documentation of the review process, including maps with all known wells, all relevant features, cross-section profiles, geologic characteristics, indices or copies of reviewed documents, historical studies, reconnaissance reports, and all relevant information that was studied.
-

iv. Corrective Action Strategies

1. Any known safety risks to storage area integrity should be addressed and mitigated prior to beginning storage operations. A remediation plan should be developed to address any issues and the plan submitted as part of the permitting process.
2. Any plugged wells that are identified in the AOR must be reviewed to confirm that they were constructed and plugged adequately. Historical plugging practices may not be adequate to prevent migration of gas, so plugged wells should be frequently monitored during the first few years of a new storage project and periodically monitored throughout the life of the storage project.
3. Unplugged or inadequately plugged wells of concern should be identified for further review.
4. Inadequately constructed or plugged wells that penetrate into or through the storage zone must then be properly reworked or adequately plugged.
5. Laterally offset wells within the buffer zone that penetrate the storage horizon, and that will remain in place, may be used as observation wells to look for communication with storage zones.
6. Initial testing of storage horizons may evaluate the AOR for any adverse impacts, early signs of which may require mitigation, or reevaluation of suitability of the area as a storage location.

d. Siting and Spacing Considerations

i. Physical Features Advantageous for Storage

1. A geologic structure with suitable capacity and flow potential to be commercially viable given its relative location to intended markets and pipeline infrastructure.
2. Close proximity to markets, which provides for storage near the end users, and offers fast response to demand.
3. Close proximity to existing pipeline infrastructure, which makes storage near major pipelines a source for storage gas, as well as outlets.
4. Close proximity to a source of gas.
5. Rural setting. Storage facilities constructed in areas with lower population density present a lower risk to human health and likely fewer land use conflicts.
6. Pipeline right-of-way access. Maintaining secure pipeline right of ways, free from encroachment, is important for safety.

ii. Physical Features Not Advantageous to Storage

1. High population areas.
2. Opposites to all the above, inadequate geologic properties, distant to source gas, markets, pipeline infrastructure, etc.
3. Existing old oil and gas wells
 - a) Areas with a long history of oil and gas production, with many abandoned and undocumented wells. These wells could become potential vertical migration pathways causing serious safety issues at the surface.
 - b) Storage fields with a large number of production wells that penetrate the caprock inherently pose a higher integrity issues than a field with fewer caprock penetrations.

iii. Lease History and Neighboring Oil and Gas Production

1. Some areas of the U.S. have a long history of oil and gas production, with many oil and gas lease holders. A potential storage field operator may need to control significant acreage for the field and buffer zones. Nearby oil and gas wells, may interfere with safe storage operations.
2. In certain areas, other subsurface mineral extraction activities, such as coal mining, may also be ongoing or have surface or subsurface lease interests in land being considered for storage. Storage operators should conduct a thorough review of the mineral ownership in their storage projects to identify potential conflicting interests.

iv. Proximity to USDWs or other protected groundwater for Depleted Reservoir Storage

1. There are areas in the U.S. where oil and gas horizons are very close vertically to USDWs or other protected groundwater. There should be adequate vertical separation, and a confining zone between the two.
2. The storage wells should be constructed with adequate casing and cementing to protect the USDW or other protected groundwater.
3. For new facilities a survey of water quality from water wells adjacent to the facility is important to consider when evaluating the siting of the facility.

e. Operational Requirements Near Sensitive Areas

- i. The storage design should include plans to monitor conditions as they pertain to well drilling and storage development for protecting the environment and health and safety of workers and the public. This includes the development of site-specific plans for known problems like geological and other hazards. (10)
- ii. Site specific requirements should include (10):
 1. Installation of protective equipment for site security and safety;
 2. Development of storage well blowout contingency plans; and
 3. Liaison with all pertinent law enforcement agencies and first responders.
- iii. Operators may consider using leak detectors, downhole shut-off valves, or other safety devices in areas near populations or gathering spaces, if risk assessment indicates they are needed. See Chapter 3 for more information on Risk Assessment.

f. Drilling Through Storage Reservoirs by Type

- i. Drilling through porosity reservoirs
 1. New third party wells within either the vertical or lateral buffer zone should be drilled and completed so the third party wells isolate the storage reservoir as recommended by the storage operator and approved by the regulatory authority. (10)
 2. The entity drilling the well should provide sufficient notice to both the storage operator and the regulatory agency. (15)

ii. Drilling through cavern storage

1. Any situations in which an entity would propose to drill through a salt or hard rock cavern to reach a productive or disposal zone beneath is not recommended.
2. In bedded salt, unlike with a depleted reservoir, the stored gas is contained within the storage cavern and does not freely flow over a large lateral area. Therefore, precautions must be taken to ensure any well passing through the bedded salt zone does not penetrate a storage cavern or come too close to the edge of the cavern. In order to preserve the integrity of the storage cavern, wells passing through the salt should be located at least a distance of $2D$ from any cavern wall, where D is the maximum diameter of the cavern, or 200 feet, whichever is greater. A cavern located closer than 100 feet to any point on the salt's perimeter is not recommended.

Chapter 5

Well Drilling, Construction, and Conversion

Introduction

The drilling, well construction, completion, or conversion of wells associated with underground storage of gas has been accomplished by the gas storage industry for many years. While the vast majority of wells utilized by the gas storage industry in the U.S. are conversions of existing oil and natural gas production wells associated with depleted hydrocarbon reservoirs, new wells are drilled and completed to replace older storage wells, to extend existing gas storage field utilization, and to develop new UGS fields. In addition to formerly depleted hydrocarbon reservoirs, new wells may be drilled into salt or hard-rock mined caverns, or aquifers. Widespread development of new natural gas producing wells with significant liquids production has increased the interest in new LPG storage fields. Well construction and completion will vary extensively between the different types of storage reservoirs (depleted oil and gas horizons, salt caverns, hard-rock caverns, and aquifers) and addressing the various differences must be considered.

Major Issues and Concerns

Perhaps the most important issue to be addressed with the drilling or conversion of any well for storage is to ensure that the construction and completion of a well prevents pathways of gas or liquids migration out of the storage reservoir and zonal isolation of the storage field reservoir from other formations. The biggest concern is that many of the wells converted from oil and gas production in depleted reservoirs are fairly old, may not meet current or contemplated regulatory requirements, and commonly require extensive workover, testing, and remedial action in order to operate with mechanical integrity. Long-term well integrity and functionality depend upon proper consideration of life-of-the-field and life-of-the-well operations and maintenance, including changes in the reservoir, fluids, rates, stimulation, workover and remediation, offset, surface conditions and parameters, and plugging and abandonment. Essential continual monitoring of current conditions with comparison versus design and expected future conditions will indicate the integrity and functionality during each life-of-well.

Main Take-Aways

- Well construction and completion can vary considerably between the different reservoir types.
- The majority of wells are vertically drilled and completed; however, some storage fields may include a well construction option for drilling horizontally in the production or injection zone, since gas can be injected or withdrawn at a higher rate per well. These wells generally do not add any additional risks with regard to well integrity or zonal isolation.
- Well drilling, construction, cementing, and completion practices should be accomplished in the safest manner possible to enhance well integrity and to ensure pathways for leakage are prevented and the gas storage reservoir or cavern is isolated.

Well Drilling, Construction, and Conversion

a. Goals of Drilling, Cementing and Completion

The goal of drilling, cementing, and completion of new wells and conversion of older wells in a gas storage reservoir is to maintain long term well and reservoir integrity. Guidelines for well drilling, construction, cementing, and conversion practices have been established in a number of API RPs and in the Canadian Standards Association should be considered by all gas storage operators and regulatory authorities where applicable to gas storage wells and facilities.

- i. The design of a well casing program in UGS operations should: (16) (17) (10) Provide for control of pressures and fluids encountered by the well;
- ii. Prevent losses of fluids;
- iii. Prevent contamination of aquifers or other uphole and downhole porous or fractured zones; and consider the following:
 1. Wellbore conditions during the running and cementing of casing;
 2. Range of operating pressures and temperatures for the well;
 3. Composition of the hydrocarbons being injected into and withdrawn from the reservoir;
 4. Cyclic mode of storage operations;
 5. Projected life of the well and facility;
 6. Integrity of the geological formations being penetrated and fluid content of each formation; and
 7. Depth of the well.

Additional considerations as to the yield strength design, collapse and tensile design, service conditions, casing setting depths, number of casing strings, pressure testing, and others need to be evaluated. A cementing plan should be designed to provide for isolation of the gas storage reservoir from all sources of porosity and permeability. Primary cementing job designs for gas storage should take into consideration the following: (17) (10) (16)

- i. Types of formations being cemented, including unconsolidated formations and their effect on cement properties:
 1. The use of salt-saturated cement across salt zones;
 2. Bottom-hole pressure and its effect on lost circulation and gas cutting of the cement;
 3. Bottom-hole temperature and its effect on cement thickening and curing times;
 4. Mud displacement; and
 5. Casing centralization and rotation.
- ii. Additional cementing considerations should include:
 1. Compressive strengths;
 2. Cement tops;
 3. Cement placement;
 4. Preflushes;

5. Cement equipment accessories;
6. Pipe movement during cement placement;
7. Wiper plugs;
8. Pressure testing and evaluation;
9. Cement bond evaluation;
10. Cementing records;
11. Specialty cementing considerations; and
12. Remedial cementing.

Operators should determine the maximum and minimum operating pressures that each gas storage well and each gas storage facility component will be subjected to during the well or component lifetime. These pressures should be reviewed, evaluated, and approved by the regulatory agency. The operating pressure range of each well and component, along with other load and condition factors, should be used in each original design, re-design, and operational plan.

Periodically the operational plan should be reviewed and confirmed as applicable to each well and component, so that operators do not exceed the minimum and maximum operating pressure of each. Prior to each workover or remediation, the above factors should be reviewed in light of future use or potential plugging and abandonment.

b. Drilling Process for Porosity Storage (Depleted and Aquifer Storage Reservoirs)

The following processes need to be considered for drilling or conversion of porosity storage wells:

- i. Wellhead control and drilling considerations and capabilities (drilling into existing storage fields under pressure and prevention of reservoir formation damage and contamination);
- ii. Protection of USDWs or other protected groundwater: (may preclude use of drilling fluids not compatible with protected groundwater);
- iii. Addressing the many wellbore issues – corrosion zones, flow zones, lost circulation zones, disposal zones, over pressurized and under pressurized zones, sloughing shales, zones prone to differential sticking, and commercial hydrocarbon-bearing zones;
- iv. Directional drilling and deviation surveys;
- v. Formation integrity and other pressure testing; and
- vi. Open-hole and cased hole geophysical logging considerations

c. Casing Program Development for Porosity Storage

The development and designing of a well construction casing program needs to address the potential protection of USDWs or other protected groundwater and isolation of other zones, while providing for control of wellbore conditions, prevention of migration pathways, and isolation of the storage reservoir.

- i. Types of casing considerations – drive pipe, conductor, mine string (if necessary), surface, intermediate(s), liners, and production casing strings; and
 - ii. Consideration of casing depths, diameters, weights, types, and use of centralizers with utilization of API and CSA standards.
-

d. Wellhead Construction for Porosity Storage

All wellheads and christmas tree assemblies should be constructed so that the fittings, valves, and flanges are rated for pressure greater than the maximum pressure exposure to the wellhead and christmas tree assembly. (18). All wellhead equipment and associated fittings, flanges, and valves should conform to API RP 6A. (18) Additionally, wellhead design should include evaluation of the following: (10)

- i. Treating and stimulation pressures;
- ii. Flow rates;
- iii. Fluid chemical composition of produced fluids and fluids used in well stimulation;
- iv. Possible solids production;
- v. Possible increases in maximum operating pressures;
- vi. Intended flow path; and
- vii. Accommodation for pressure and/or temperature monitoring of tubular and annular spaces.

A review and evaluation of existing state and federal regulatory requirements for wellhead construction should be considered, but gas storage wellhead construction may require additional designs beyond current regulatory standards to ensure well integrity and safety issues.

e. Well Cementing and Evaluation for Porosity Storage

The purpose of cement in the construction of a new or converted gas storage well is to maintain the integrity of the storage reservoir by providing isolation of the reservoir from communication with other permeable and porous geological formations through the drilled wellbore. (10). Cement should meet or exceed quality standards set in API RP 10A. (19) Gas storage wells should have a primary cementing program for each casing string that ensures isolation of zones and elimination of migration pathways. (19)

Such a program needs to provide for on-site necessary changes to cementing programs based upon actual wellbore conditions, which may include changes to the types of cement, changes to cementing equipment, and the use of variety of additives to ensure a successful cement job and provide wellbore and reservoir integrity.

Evaluation of cement placement and quality is accomplished to determine that a competent seal exists to prevent migration of gas and/or fluids from the storage reservoir or other geological formations of interest. (10). Evaluation of the cement is done through assessment of the cementing records and through cement evaluation logging. Cement evaluation logging should consider the cement cure time determined in the cement design and recognize that it may take time for the cement to reach a sufficient compressive strength for accurate interpretation of cement placement and bond quality.

f. Well Completion Methodology for Porosity Storage

The gas storage operator should design and conduct any well completion or stimulation operations in such a manner to verify that pressure, flow rates, and other mechanical conditions have no adverse impacts on the storage reservoir, confining zone(s), or mechanical integrity of the well, or causes communication between the storage zone and other porous geological formations. (10). Completion methodology in porosity storage can include:

- i. Open-hole completions/ re-completions;
- ii. Cased-hole perforations/ re-completions;
- iii. Coiled tubing jet cleaning;
- iv. Acid treatments or hydraulic fracturing stimulation; and
- v. Liner and screen placement.

For all wells in porosity storage additional completion methodology may include:

- i. Cemented pipe with perforations; or
- ii. Open hole with a slotted liner and sand screen; or
- iii. Liner/ production casing with packers; or
- iv. Gravel pack completion.

g. Drilling Wells for Bedded and Domal Salt Cavern Storage

The following processes need to be considered for drilling or conversion of salt cavern storage wells:

- i. Wellhead control considerations and capabilities (drilling into existing storage fields under pressure);
- ii. Protection of USDWs or other protected groundwater– may preclude use of drilling fluids not compatible with protected groundwater;
- iii. Addressing the many wellbore issues such as corrosion zones, flow zones, lost circulation zones, disposal zones, and commercial hydrocarbon-bearing horizons;
- iv. Directional drilling and deviation surveys;
- v. Preparation for drilling into an existing storage reservoir – pressure issues (including inflow or loss of circulation);
- vi. Use of salt-saturated drilling fluid in the drilling operations into the salt to prevent dissolution of the salt and protection of the top of the salt; and
- vii. Open-hole and cased hole geophysical logging considerations.

h. Casing Program for Bedded and Domal Salt Cavern Storage

- i. Development and design of a well construction casing program that addresses the potential protection of USDWs or other protected groundwater, and isolation of other zones, while providing for control of wellbore conditions, prevention of migration pathways, and isolation of the storage reservoir;
- ii. Types of casing considerations – drive pipe, conductor, mine string (if necessary), surface, intermediate(s), and production casing strings;
- iii. In domal salt wells, two casing strings should be set into the salt. (17) These casing strings are the last intermediate and production casing strings; and experience has shown that setting the last intermediate casing between 150 to 200 feet into the salt may be necessary for isolation of the confining zone(s);
- iv. Consideration of casing depths, diameters, weights, types, and use of centralizers and utilization of API and CSA standards;
- v. Utilization of tubing string in cavern development and salt dissolution well connectivity in bedded salt deposits;
- vi. The use of a mule shoe at the bottom of the hanging string adds additional protection to an overfill event. As the interface of the product in the cavern starts to uncover the top of the mule shoe only a portion of the product starts to come up the hanging brine string (instead of a full diameter return of product to the surface in an overfilling event) which minimizes the impact of the overfill and is helpful if the weep hole has salted over for some reason; and
- vii. Additionally a weep hole should be placed at a calculated distance from the top of the mule shoe. The location of the weep hole is dependent on the diameter of the cavern (barrels per foot) and the typical filling rate. This allows the desired or required margin of safety to be calculated.

i. Wellhead Construction for Bedded and Domal Salt Cavern Storage

All wellheads and christmas tree assemblies should be constructed so that the fittings, valves, and flanges are rated for pressure greater than the maximum pressure exposure.. All wellhead equipment and associated fittings, flanges, and valves should conform to API RP 6A. (18) Additionally, wellhead design should include evaluation of the following: (17)

- i. Treating and stimulation pressures;
- ii. Flow rates;
- iii. Fluid chemical composition of produced fluids and fluids used in well stimulation;
- iv. Possible solids production;
- v. Possible increases in maximum operating pressures;

- vi. Intended flow path; and
- vii. Accommodation for pressure and/or temperature monitoring of tubular and annular spaces.

A review and evaluation of existing state and federal regulatory requirements for wellhead construction should be considered, but gas storage wellhead construction may require additional designs beyond current regulatory standards to ensure well integrity and safety issues. Typically, two separate wellhead designs are used during the service life of a cavern system: One for solution mining development of the caverns and one for gas storage service. (18) The wellhead design for gas storage service typically includes a snubbing or shut-off valve to allow for well workovers under pressure. (18)

j. Well Cementing and Evaluation for Bedded and Domal Salt Cavern Storage

The purpose of cement in the construction of a new or converted gas storage well is to maintain the integrity of the storage reservoir by providing isolation of the reservoir from communication with other permeable and porous geological formations through the drilled wellbore.. Cement should meet quality standards set in API RP 10A (19) or exceeds the requirements set in these standards. Each gas storage well should develop a primary cementing program for each casing string that ensures isolation of zones and elimination of migration pathways. Salt-saturated cements should be utilized in the cementing of any casing strings completed within the salt deposits.

Such a program needs to provide for on-site necessary changes to cementing programs based upon actual wellbore conditions, which may include changes to the types of cement, changes to cementing equipment, and the use of variety of additives to ensure a successful cement job and provide wellbore and reservoir integrity.

Evaluation of cement placement and quality is accomplished to determine that a competent seal exists to prevent migration of gas and/or fluids from the storage reservoir or other geological formations of interest. (15) Evaluation of the cement is done through assessment of the cementing records and through cement evaluation logging. Cement evaluation logging should not take place until the cement cure time determined in the cement design has allowed the cement to reach a sufficient compressive strength for accurate interpretation of cement placement and bond quality.

k. Well Completion Methodology for Bedded and Domal Salt Cavern Storage

After initial drilling and well completion, dissolution of the salt is undertaken to create the cavern. Cavern development is initiated by salt dissolution utilizing either the direct circulation or reverse circulation method. Direct circulation involves the injection of water or under saturated brine down the longest hanging string, which starts dissolution of the salt at the bottom of this string. The saturated brine is then pumped out of the shortest hanging string back to the surface. The reverse circulation method involves the injection of water or under saturated brine down the shortest hanging string and then the saturated brine is returned to the surface through the longest hanging casing string. During the cavern creation process, care must be taken to ensure the cavern grows in size and shape as it was engineered and designed. In bedded salt deposits, multiple salt cavern well completions are utilized and single hanging strings are typically used once the wells have been connected within the salt.

A cavern can typically be developed in phases. There may be as many as three distinct phases needed for gas storage in salt caverns and these phases can include: (17)

- i. Initial development of the sump only (using direct circulation);
- ii. Sump and chimney creation (utilizing the direct circulation method); and
- iii. Development of the upper cavern and roof (using reverse circulation method).

Completion methodology can be different if storage of LPG versus natural gas is utilized.

I. Drilling Process for Wells in Hard Rock Cavern Storage

Typically, hard rock caverns are created by mechanically mining out hard rock using the “room and pillar” method at relatively shallow depths ranging from approximately 230 to 650 feet below the surface. (10) (2) The rock must be hard enough for cavern stability and the rock types typically utilized are non-porous, such as chalk, shale, limestone, dolomite, and granite. The construction and well drilling processes need to consider:

- i. Wellhead control considerations and capabilities (drilling into existing storage fields under pressure);
- ii. Protection of USDWs or other protected groundwater (may preclude use of drilling fluids not compatible with protected groundwater);
- iii. Addressing the many wellbore issues such as corrosion zones, flow zones, lost circulation zones, disposal zones, and commercial hydrocarbon-bearing horizons;
- iv. Preparation for drilling into an existing storage reservoir – pressure issues and prevention of reservoir formation damage and contamination;
- v. Formation integrity and other pressure testing; and
- vi. Open-hole geophysical logging considerations



Figure 5-1 is a photograph of a hard rock cavern under construction in shale in Middletown, Ohio in 1959. Source: <http://caplaconference.com/wp-content/uploads/2015/04/Pipelines>.

m. Casing Program for Mined-out Cavern Storage

A casing program may seem less complex due to the shallow depths of most of these caverns but can become complicated by the large diameter casing strings involved, which are not normally found in other types of storage programs. Development and design of a well construction casing program that addresses the potential protection of USDWs or other protected groundwater and isolation of other zones, while providing for prevention of migration pathways and isolation of the storage reservoir is critical. Depths of casing, diameters, weights, types, use of centralizers, and utilization of API standards must be considered. Many off-the-shelf tools are not available for large diameter boreholes and casing string.

n. Wellhead Construction

Wellhead configuration of hard rock caverns is entirely different from other gas storage reservoirs due to the larger casing diameters and completion methodology. Figure 5-2 illustrates a typical wellhead design for a hard rock cavern and is often called the “dome.”



Figure 5-2: Example of wellhead configuration of hard rock cavern storage.
Source: <http://caplaconference.com/wp-content/uploads/2015/04/Pipelines.pdf>

o. Well Cementing and Evaluation for Hard Rock Cavern Storage

Development of a cementing program for each casing string to ensure isolation of zones and elimination of migration pathways is very important. Operators need to adjust cementing programs based upon actual wellbore conditions. An operator should maintain cementing records and conduct cement evaluation logging as needed. One of the most critical components of the hard rock cavern well is cementing of the last casing string, especially around the casing shoe. (2)

p. Well Completion Methodology for Hard Rock Cavern Storage

Completion methodology is different than other types of storage due to density differences with LPG versus natural gas. Figure 5-3 illustrates the typical completion methodology developed for hard rock caverns.

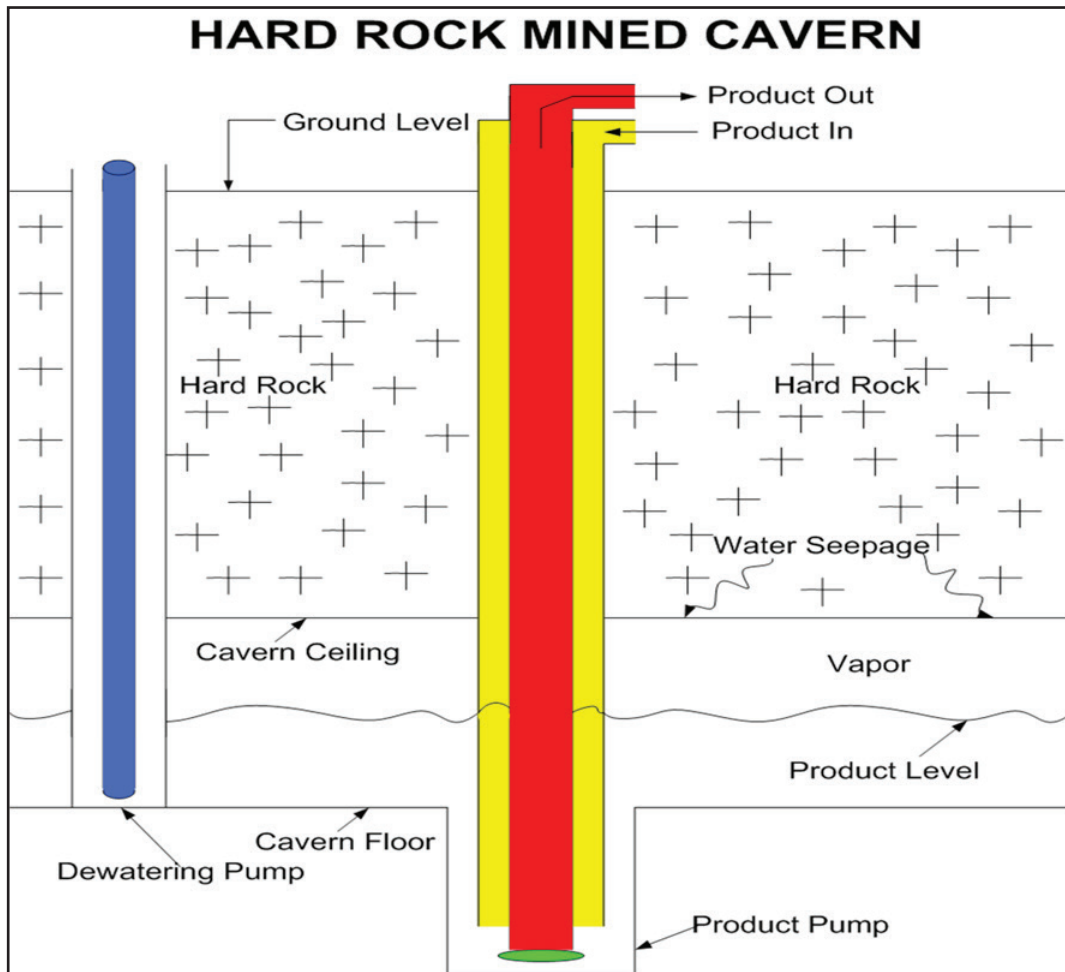

Figure 5-3: Example of a well construction diagram of a hard rock cavern. Source: <http://ca-placonference.com/wp-content/uploads/2015/04/Pipelines.pdf>

q. Plugging and Abandonment of Shafts

Mine shafts used for creating the cavern mined out in the rock and for operation needs to be properly plugged and sealed to prevent migration and to isolate the storage reservoir. The concrete plug to seal the shaft should be designed to be sufficiently long enough and to have adequate capacity against shearing. (20)

Chapter 6

Well Integrity Testing

Introduction

Mechanical integrity testing of underground gas and hydrocarbon storage wells is a critical aspect of long-term success for any gas storage project. Gas storage wells vary broadly in age and construction around the country and can include wells that are over 50 years in age, converted from oil and gas production wells, or completed into bedded or domal salt deposits or mined-out caverns, and new wells specifically designed for injection and production of stored gas or other hydrocarbons. As such, testing and evaluation methods for assessing mechanical integrity can vary considerably. Furthermore, regulatory scrutiny of well integrity and its assessment has increased due to recent incidents and the risk of new incidents. This section will review objectives and details pertaining to approaches and methods of assessing the integrity of gas and/or hydrocarbon storage wells using a holistic approach to the evaluation of well integrity.

Major Issues and Concerns

One of the greatest threats to gas or hydrocarbon storage is the loss of well integrity. Approximately 79 percent of existing gas storage fields in the U.S. was converted from depleted oil and gas reservoirs, with a large percentage of the wells in these fields being rather old so that wells were often not drilled and completed to today's standards. Consequently, well integrity is an ongoing issue in many storage reservoir fields that must be addressed using the proper (i.e., modern) well integrity testing methodologies and remediating any well integrity deficiencies. In addition, injection/withdrawal wells represent a significant potential vulnerability in cavern storage facilities and their integrity is of critical importance.

Main Take-Aways

- Lack or loss of well integrity is one of the greatest threats and risks to any gas storage project.
- There are a variety of well integrity testing methods, but no single testing method alone should be used to determine well integrity.
- Assessment of well integrity requires a holistic, risk based approach.

Objectives, types and methods of mechanical integrity testing

a. Objectives of Integrity Testing

Mechanical integrity is the design, installation, operation and maintenance of all well equipment to a standard that ensures the safe containment of well fluids and injectate for the life of the well. (21) Simply put, mechanical integrity is a lack of significant leakage within the well and wellbore. Ongoing routine mechanical integrity testing is a critical aspect of the long-term success of any gas storage project and can help ensure the following objectives are met:

- i. Protection of USDWs or other protected groundwater;

- ii. Proper well configuration for the demands of underground gas and hydrocarbon storage;
- iii. Safety and risk prevention; and
- iv. Meeting regulatory goals and operational demands.

A holistic, risk based approach to mechanical integrity testing should be used to facilitate the determination of well integrity. This type of an approach does not rely on any single tool, but evaluates overall well integrity using a variety of industry standard tests and logs that have been refined to achieve specific testing objectives. While any one test may indicate a potential concern, a compilation of tests in a holistic approach will help to refine and/or clarify whether a well has mechanical integrity. The holistic well integrity assessment process should include a series of analytical reviews and tests which includes but is not limited to the following:

- i. Well casing and cementing review;
- ii. Well integrity testing;
- iii. Well logging; and
- iv. Routine monitoring.

Test objectives and methodology should be tailored for gas storage wells. Often, industry standard practices that were developed for production and water injection wells may not be appropriate for the assessment of gas storage wells. In order to be effective, specific testing methods that are appropriate for gas storage wells, together with detailed implementation expectations (e.g., fluid-filled annulus, logging speeds, etc.) and explicit requirements for test results (e.g., pressure testing to maximum allowable internal pressure, etc.) must be established.

It should be noted that some types of tests, particularly tests that require the removal of tubing, change of downhole conditions (e.g., filling the well with liquid), or an insertion of new tools downhole introduce some risk to well operation during those times. Thus, the risks associated with performing tests should be considered when determining testing schedules, and the application or development of tests that require less invasive changes in the well operations should be encouraged. This fits very well into a holistic, risk-based approach, where some types of tests should be performed more frequently than others based on the information that they give, the well-specific risks that have been determined, and the risks associated with the testing, among others.

b. Types of Well Integrity

When evaluating well mechanical integrity, both internal and external integrity must be considered and evaluated for a complete assessment. Internal and external well integrity considerations are illustrated in Figure 6-1 and discussed in further detail below. Certain integrity considerations are not always applicable to salt cavern and hard rock mined storage.

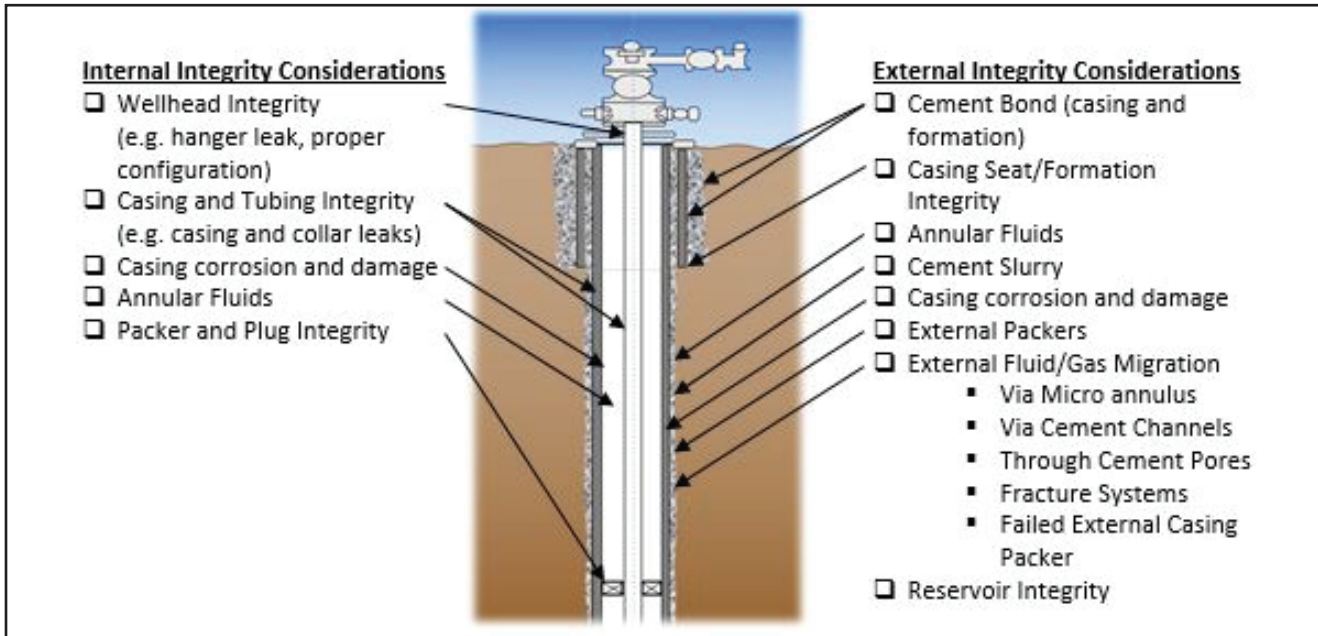

Figure 6-1: Diagram Illustrating Internal and External Mechanical Integrity Considerations
Source: ALL Consulting, Inc., 2017

- i. **Internal Integrity:** Internal well integrity generally refers to the portion of a well extending from the production casing inward and including all components in that space from the wellhead to the bottom of the casing. This includes but is not limited to casing, tubing, packers, plugs, and well head components. Thus, when testing the internal integrity of a well, the testing is aimed at the current condition of well components, changes in the condition of the components between tests, and the ability of those components to contain and control the movement of fluids and or gases between the target formation or cavern and the surface.
- ii. **External Integrity:** External well integrity generally refers to the portion of a well extending from the production casing outward to the wellbore contact with the formations surrounding the well and including all the components in that space (e.g., cement). When testing a well's external integrity, the testing will reflect the adequacy and condition of the well components and their effectiveness in protecting USDWs or other protected groundwater, prohibiting communication of fluids and gases between geologic zones, and limiting the flow of fluids and gases to/from the target zone to the production casing.
- iii. **Other Integrity Considerations:** Although not specifically addressed within this document, other items that should be considered with a holistic evaluation may include well pad, pits, impoundments, tanks, trucks, pumping equipment, other surface equipment, and pipelines.

c. Well Integrity Testing Methods and Technologies

The following paragraphs discuss a variety of internal well integrity testing methods and technologies. Table 6-1 indicates which of these technologies are most appropriate for testing internal vs. external integrity and also notes which can be used for either. The list of testing methods comprised here is not entirely comprehensive and does not account for future testing developments.

Mechanical Integrity Testing Methods	Internal or External Integrity	Test/Log Objective	Well Preparation	Comments/Considerations
Mechanical Integrity Test				
Standard Annular Pressure Test	Internal	<ul style="list-style-type: none"> – Demonstrate no leaks in the casing-tubing annulus – Casing/packer leak detection 	<ul style="list-style-type: none"> – Wellbore and well must be full of fluid – Must stabilize temperature in well and annulus – Must pull tubing and set bridge plug for wells without a packer 	<ul style="list-style-type: none"> – Pass/Fail Criteria can be established – Can be used on any well – No unapproved fluid additives – Testing pressure should be equal to at least the maximum allowable injection pressure
Annular Pressure Build-up Test	External (including wellhead) & Internal	<ul style="list-style-type: none"> – Identify gas flow outside of casing (annular pressure) 	<ul style="list-style-type: none"> – Annuli and casing must be bled to 0 psig prior to initiating test – Shut-in annuli should be allowed to vent for a period of time prior to testing. 	<ul style="list-style-type: none"> – Pass/Fail Criteria can be established – Interpretation is relatively straightforward (type curves are available for comparison) – Test can be influenced by outside factors such as barometric pressure, mud clogging or freezing of lines, etc. – Gauges must be properly sized for the anticipated pressures – Continuous data recording are important to confirm quality of results
Annular Venting Flow Rate Test	External & Internal	<ul style="list-style-type: none"> – Identify flow of gas to surface as an indication of a leak 	<ul style="list-style-type: none"> – Shut-in annuli should be allowed to vent for a period of time prior to testing. 	<ul style="list-style-type: none"> – Pass/Fail Criteria can be established – Simple interpretation – Two test types: <ul style="list-style-type: none"> – Manometer Tests: Quantitative assessment of flow – Balloon Test/Bubble Test: Qualitative assessment of flow (used when flow is below quantifiable rates)
Wellhead Methane Monitoring	External & Internal	<ul style="list-style-type: none"> – Identify flow of gas to surface as an indication of a leak 	<ul style="list-style-type: none"> – None 	<ul style="list-style-type: none"> – Pass/Fail Criteria can be established – Simple interpretation – Various direct-reading instruments are available that can detect methane either directly or as a component of combustible gas – Field procedures must be standardized to ensure consistent results
Nitrogen - Brine Interface Test	External (Cavern) & Internal (Well)	<ul style="list-style-type: none"> – For domal and bedded salt caverns and mined-out caverns – Identify internal or external leaks as well as integrity of the storage cavern itself 	<ul style="list-style-type: none"> – Not necessary to remove tubing – Must allow stabilization of pressure/temperature – Use of fully saturated brine helps reduce stabilization time 	<ul style="list-style-type: none"> – Pass/Fail Criteria can be established – The test is not practical for caverns with large, flat roofs and no cavern neck –
Cavern Wells – Freshwater-Brine Interface Test	Internal	<ul style="list-style-type: none"> – For domal, bedded and mined salt reservoirs 	<ul style="list-style-type: none"> – Useful when packer or plug sealing is difficult – May avoid depressurizing cavern 	<ul style="list-style-type: none"> – Pass/Fail Criteria can be established – Does not account for changes in cavern pressure; a reference well or tubing must be used for comparison – May not be an approved test method in some states.
Geophysical Logging				
Temperature Log	External & Internal	<ul style="list-style-type: none"> – Casing Leak Detection – Identify Behind Casing Flow – Entry/Exit Point Delineation 	<ul style="list-style-type: none"> – Remove Tubing – Wellbore must be full of fluid – Stabilization Period (at least 12-24 hours) 	<ul style="list-style-type: none"> – Misinterpretation of results is possible – Run logs in sets: production casing closed and surface casing open, production casing open and surface casing closed – Sensitive to the differing thermal conductivities of different sedimentary rock types

Mechanical Integrity Testing Methods	Internal or External Integrity	Test/Log Objective	Well Preparation	Comments/Considerations
Audio Log	External & Internal	<ul style="list-style-type: none"> - Casing Leak Detection - Identify Behind Casing Flow - Entry/Exit Point Delineation - Distinguish Flow Type 	<ul style="list-style-type: none"> - Remove Tubing - Wellbore must be full of fluid - Stabilization Period (at least 12-24 hours) 	<ul style="list-style-type: none"> - Misinterpretation of results is possible - Run logs in sets: production casing closed and surface casing open, production casing open and surface casing closed
Ultrasonic Noise Log	Internal	<ul style="list-style-type: none"> - Casing Leak Detection - Can detect leaks through tubing and casing 	<ul style="list-style-type: none"> - Remove Tubing - Operate in dry hole - May be run inside tubing - Logging rate ~30fpm 	<ul style="list-style-type: none"> - Run logs in sets: production casing closed and surface casing open, production casing open and surface casing closed
Cement Evaluation Logs – 1st Generation				
Cement Bond Log (CBL)	External	<ul style="list-style-type: none"> - TOC Determination - Casing/Formation Bond Evaluation 	<ul style="list-style-type: none"> - Remove Tubing - Wellbore must be full of fluid 	<ul style="list-style-type: none"> - Tool widely available - Historical use results in consistent interpretation - Sensitive to wellbore conditions
Radial Cement Bond Log (RCBL)	External	<ul style="list-style-type: none"> - TOC Determination - Casing/Formation Bond Evaluation - Casing Bond Radial Display 	<ul style="list-style-type: none"> - Remove Tubing - Wellbore must be full of fluid 	<ul style="list-style-type: none"> - Tool widely available - Historical use results in consistent interpretation - Sensitive to wellbore conditions
Cement Evaluation Logs – 2nd Generation				
Cement Evaluation Tool (CET)	External & Internal	<ul style="list-style-type: none"> - Casing Cement Bond Evaluation - Identify Cement Channeling - Cement Compressive Strength - Casing wear/corrosion Indication 	<ul style="list-style-type: none"> - Remove Tubing - Wellbore must be full of fluid 	<ul style="list-style-type: none"> - Simpler interpretation - Less sensitive to borehole conditions - No cement to formation bond information
Segmented Bond Tool (SBT)	External	<ul style="list-style-type: none"> - Determining Cement Seal - Identify Cement Channeling - Cement Compressive Strength 	<ul style="list-style-type: none"> - Remove Tubing - Can be run in fluid or gas 	<ul style="list-style-type: none"> - Insensitive to wellbore conditions
Ultrasonic Imager Tool (USIT)	External & Internal	<ul style="list-style-type: none"> - Casing Cement Bond Evaluation - Identify Cement Channeling - Cement Compressive Strength - Casing Corrosion Detection - Casing Internal/External Damage - Casing Thickness Measurement 	<ul style="list-style-type: none"> - Remove Tubing - Scrap casing - Wellbore must be full of fluid 	<ul style="list-style-type: none"> - Simpler interpretation - Less sensitive to wellbore conditions - No formation to cement bond information - Newer tools such as slim memory CBL and radial CBL can be run thru tubing
Corrosion Logs				
Multi-Finger Caliper Log	Internal	<ul style="list-style-type: none"> - Radial measurement of tubing/casing inside diameter 	<ul style="list-style-type: none"> - Remove Tubing - Scrap casing 	<ul style="list-style-type: none"> - Used to identify zones of thinned casing wall thickness assuming a uniform (constant) external diameter
Electromagnetic Casing Inspection Log	Internal	<ul style="list-style-type: none"> - Casing Internal and External Corrosion Indication - Casing Thickness Measurement 	<ul style="list-style-type: none"> - Some can be run through tubing 	<ul style="list-style-type: none"> - Operates in liquid or gas environments - Low Frequency pass can scan multiple casing strings
Magnetic Flux Leakage Tool	Internal	<ul style="list-style-type: none"> - Casing Corrosion Indication - Casing Thickness Measurement 	<ul style="list-style-type: none"> - Remove Tubing - Scrap casing 	<ul style="list-style-type: none"> - The tool can measure metal loss both internally and externally. - May not be effective if corrosion is continuous or has limited variation over an entire segment of casing.

Mechanical Integrity Testing Methods	Internal or External Integrity	Test/Log Objective	Well Preparation	Comments/Considerations
Magnetic Flux Leakage Tool	Internal	<ul style="list-style-type: none"> – Casing Corrosion Indication – Casing Thickness Measurement 	<ul style="list-style-type: none"> – Remove Tubing – Scrap casing 	<ul style="list-style-type: none"> – The tool can measure metal loss both internally and externally. – May not be effective if corrosion is continuous or has limited variation over an entire segment of casing.
Ultrasonic Imager Tool (USIT)	– See Entry Above			
Imaging Equipment				
Infrared Camera	External (including wellhead and supporting surface equipment) & Internal	<ul style="list-style-type: none"> – Identify flow of gas to surface as an indication of a leak 	<ul style="list-style-type: none"> – Not necessary to remove Tubing 	<ul style="list-style-type: none"> – IR camera equipment does not identify chemical species and does not estimate flow rate – Baseline monitoring should be conducted prior to operations in order to establish background conditions – Periodic monitoring is required to demonstrate ongoing containment/compliance
Downhole Video Log	Internal	<ul style="list-style-type: none"> – Identify compromised casing (corrosion, mechanical wear, collapse or breach) 	<ul style="list-style-type: none"> – Remove Tubing 	<ul style="list-style-type: none"> – Downhole video equipment not always available through traditional logging service companies
Abbreviations and Acronyms CBL – Cement Bond Log CET – Cement Evaluation Tool CPET – Corrosion Protection Evaluation Tool fpm – feet per minute GR – Gamma Ray Log IR – infrared RCBL – Radial Cement Bond Log RTS – Radioactive Tracer Survey SBT – Segmented Bond Tool TOC – top of casing USIT – Ultrasonic Imager Tool URS – Ultrasonic Radial Scanner				

Table 6-1: Mechanical Integrity Testing Matrix

d. Internal Well Integrity

- i. **Standard Annular Pressure Test (SAPT)**
 The Standard Annular Pressure Test (SAPT) is a common method used to demonstrate internal well integrity. The SAPT assesses the ability of the annulus of a well to maintain an applied test pressure, thereby indicating the presence or absence of leaks in the system (i.e., packer, tubing, casing, and wellhead).
- ii. **Downhole Video Log**
 This tool consists of a light source and video camera that can record a continuous video image of the internal surfaces of a well. Some tools are configured to allow a view looking either straight down the well or laterally out to the side to provide greater detail of the internal casing surfaces. These videos are useful for well integrity evaluations where they can provide a visual image of scale, corrosion; mechanical wear, etc. See Figure 6-2 for an example.

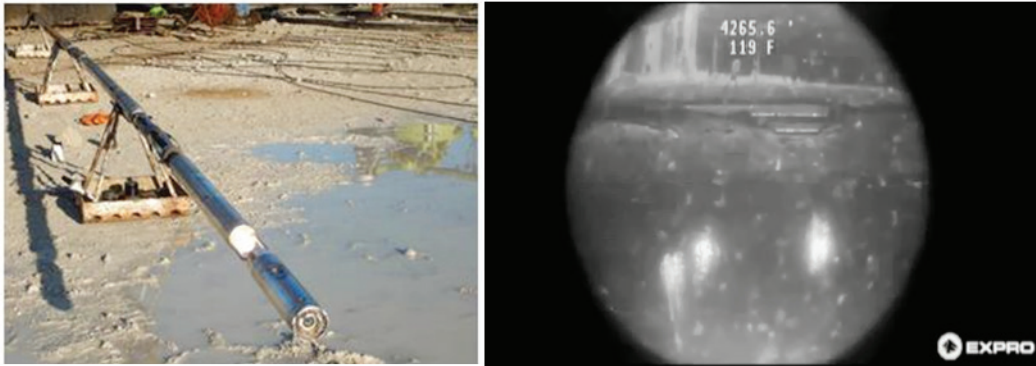

Figure 6-2: Downhole Video Tool and Snapshot from Video Log Showing Exposed Casing Threads at a Pipe Joint
Source: EXPRO, 2016

- iii. **Nitrogen-Brine Interface Test (Cavern Wells)**
 The Nitrogen-Brine (or product) Interface Test can be used to assess the internal integrity of a storage well and/or the integrity of a cavern. Nitrogen is injected into the well, displacing brine or product until the nitrogen-brine interface is either just above the base of the casing (casing test) or below the bottom of the casing (cavern test). Geophysical tools are used to monitor the nitrogen-brine interface if there is a leak above the interface. A calculated leak rate can be derived from interface movement measurements. It is recommended that all stored product be removed from the reservoir to the extent possible when performing this test.
- iv. **Freshwater-Brine Interface Test (Cavern wells)**
 The Freshwater-Brine Interface Test is used as an alternative test method where use of the SAPT is impractical. (22) The test requires that the reservoir be filled with brine and then freshwater is injected into the wellbore, displacing brine to about 50 feet from the bottom of the well. Wellhead pressure is monitored, which will indicate an upward movement of the freshwater-brine interface. To distinguish this pressure change from variations caused by changes in cavern pressure, it is compared to pressure measured either at a nearby reference well or the pressure in a column of fluid in the injection tubing may be used.
- v. **Infrared Imaging**
 The infrared (IR) camera provides a reliable, qualitative screening tool with which to identify fugitive hydrocarbon emissions from surface equipment (see Figures 6-3 and 6-4). The sensor in the IR camera detects specific wavelengths that correspond to the absorption wavelengths of chemicals present in the atmosphere. IR cameras are particularly useful for the evaluation of wellhead and equipment integrity. They provide real time identification of leaks which in turn allows for informed decision making and for repair/remediation tasks, some of which can be conducted very quickly and at limited expense.



Figure 6-3: Surveying Wellheads for Potential Fugitive Emissions
Source: ALL Consulting, 2015

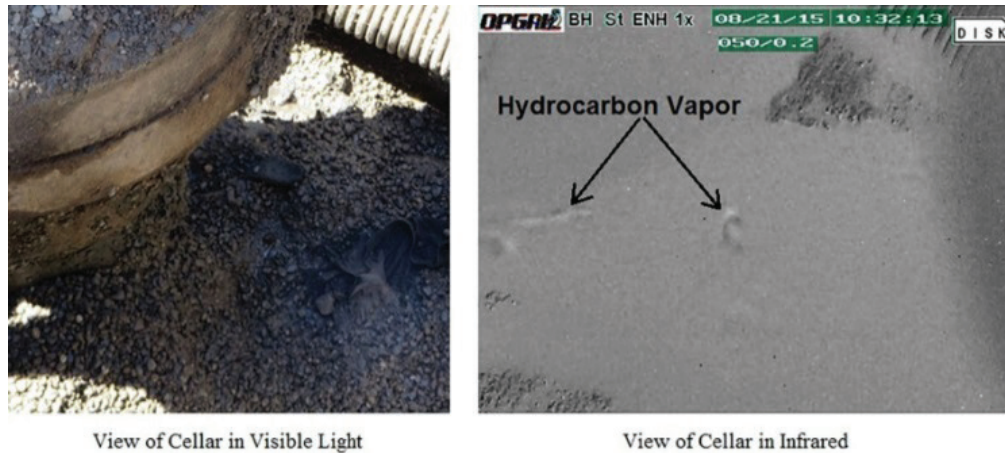

Figure 6-4: Photographs of a Cellar in Visible Light (Left) and in Infrared (Right)
Source: ALL Consulting, 2015

e. External Well Integrity

i. Pressure Build-up Testing

Pressure build-up testing should be a main component of any routine monitoring and assessment of external mechanical integrity. A pressure build-up test consists of closing the vent for the well annulus being tested and allowing pressure to build-up on the annulus for a specified duration of time. The results can then be interpreted to assess the pressure within an annulus and the nature of the pressure build-up rate. Considerations of this testing includes:

1. The continuous collection of pressure data using transducers with data loggers is preferred over periodic observation of gauges.
2. Transducer pressure ranges and error bands should be based on anticipated pressures to ensure accuracy of test results.
3. Proper planning and preparation are vital to prevent testing errors and anomalous conditions (mud in annular risers, freezing of test assemblies during winter months, and leaks in connections points of test assemblies).
4. Static shut-in annular pressure should be bled-off and the annulus allowed to vent for a period of time to allow the wellbore to stabilize prior to initiating the pressure build-up test.

ii. Annular Venting Flow Rate Test

Annular venting flow rate tests are performed to quantify the volume of gas that may be present in the casing or annulus of a well. In conjunction with shut-in pressure build-up tests, they help to identify and characterize wellbore gas intrusion and are a key component in the routine assessment of well integrity. Elements of annular venting flow rate testing are:

1. Two quantitative devices are appropriate to measure annular flow rates in gas wells: the orifice well tester and the critical flow prover. They are appropriate for testing wells with different pressure ranges: (23)
 - a. Orifice Well Tester: For use when upstream pressure is less than 15 psig.
 - b. Critical Flow Prover: For use with higher flows and where pressure on the upstream side of the plate or choke is at least twice as large as the down stream pressure.

2. Testing is conducted using a manometer. The pressure differential on the manometer is cross referenced to established flow rate tables which are based on laboratory results. (23)
3. Two qualitative methods may be used when flow rates are too low to be measured using the manometer: (24)
 - a. Balloon Test: The balloon test consists of allowing a small balloon (4 to 6 inches) to inflate for 10 minutes. Photographic documentation of the balloon is taken at the completion of the 10-minute interval.
 - b. Bubble Test: A bubble test is performed by running a 3/8-inch or 1/2-inch diameter tube from the casing riser into a 5-gallon bucket that is half-filled with water. Bubbles floating to the top of the water in the bucket are counted and recorded over a 10-minute period.

iii. Geophysical Logs

1. Temperature Log
Temperature logging is an industry- and regulatory-accepted tool for evaluating both internal and external mechanical integrity. It is based on the fact that temperature typically increases uniformly with depth in natural settings unaffected by human influence. A deviation from that normal gradient can result from the presence of a fluid derived from a different depth (and hence a fluid at a different temperature) or gas entering the wellbore. (25) Considerations in temperature logging include:
 - a. Standardized logging practices should be used and the well must be properly prepared in order to ensure quality of logging results.
 - b. The tubing must be removed, the wellbore must be 100 percent filled with fluid, and the well should be allowed to stabilize for a minimum of 12 to 24 hours prior to initiating logging activities.
 - c. The temperature log should be completed on the down-pass with a consistent speed of no more than 30 feet per minute.
 - d. Temperature logs are predominantly conducted and interpreted in conjunction with audio logs.
2. Audio Log
Audio logging equipment and techniques have been refined to become industry- and regulatory-accepted tools for evaluating external mechanical integrity. Simply, an audio log is a series of audible sound measurements recorded by a hydrophone at prescribed intervals throughout a wellbore. By analyzing the frequency structure, amplitude and depth of recorded noise, the type of flow, magnitude of flow, and origin of flow can be identified. (26) Audio logging considerations include:
 - a. As with temperature logs, the tubing must be removed and the wellbore must be 100 percent filled with fluid.
 - b. The audio log should be completed by stopping at stationary intervals of no more than 250 feet, allowing the noise to stabilize for a minute or more as needed, and recording the ambient noise.
 - c. Additional stationary intervals should be completed above, adjacent, and below casing shoes, perforations, and any anomalies identified on a temperature log.

3. **Ultrasonic Noise Log**
Ultrasonic Noise Logging is a relatively new sound log that focuses on monitoring sound characteristics of gas leaks through casing. Unlike normal audio logs, which record acoustic energy between 200 Hz to 6 KHz, ultrasonic logging measure energy in the 40 KHz range where energy from a small casing breach is likely to occur. Detection of leak rates as small as 0.0024 gallons per minute is reportedly possible.
4. **Cement Evaluation Logs**
Cement evaluation is a critical component of the assessment of external mechanical integrity. In combination with casing and cementing records review, the completion and analysis of cement evaluation logs provide insight into the presence of cement behind casing along with the level of cement bond to both the casing and formation. (27) Additionally, cement evaluation logs can also identify cement conditions such as micro-annulus, channeling, and compromised cement. (28)

A wide variety of cement evaluation logs are available to assist with the assessment of casing and cement integrity. These can be generally grouped into acoustic and ultrasonic logs. Cement evaluation logs are often run in combination to provide a more robust evaluation of cement and cement bond. Examples of each are provided below along with a brief description of the tool.

- a. **Cement Bond Log (CBL):** The acoustic CBL is the most commonly used cement evaluation log. (29) The CBL is an acoustic logging tool that measures the changes in the acoustic signal as an indication of the integrity of the cement bond. However, CBL's are a qualitative tool because they do not measure the bond through the entire 360 degree circumference of the well.
- b. **Radial Cement Bond Log (RCBL):** Similar to a CBL, an RCBL is an acoustic logging tool that measures the changes in the acoustic signal as an indication of the integrity of the cement bond. It incorporates eight radial receivers that provide 360 degree coverage of the surveyed casing section.
- c. **Cement Evaluation Tool (CET):** A CET log is an ultrasonic tool utilizing 8 transducers located at 45 degree increments for full wellbore coverage. The CET is capable of identifying cement channels and contaminated cement. It also provides a determination of cement compressive strength and casing corrosion.
- d. **Segmented Bond Tool (SBT):** An SBT is an ultrasonic tool that uses 6 padded receptors to measures cement bond integrity for full 360 degree coverage of the casing. SBT has advantages over conventional tools (i.e., acoustic tools) because is less sensitive to borehole conditions (e.g., bore hole fluids, fast formations, tool centering, etc.).
- e. **Ultrasonic Imager Tool (USIT):** A USIT log is an ultrasonic tool that uses a rotating receiver to measure 360 degree coverage of cement bond integrity as well as casing wall thickness and corrosion detection. As with other ultrasonic tools, interpretation of USIT log is not as dependent on wellbore conditions.
- f. **Isolation Scanner:** The Isolation Scanner combines pulse-echo technology with an ultrasonic technique of flexural wave imaging to evaluate cement job and casing condition for a wide range of cements – heavy, traditional to light weight cements. The older CBL/USIT logs may make it difficult to evaluate cements with low acoustic impedance or cements contaminated with mud while the isolation scanner differentiates between high-performance light weight cements from liquids and maps annulus material as solid, liquid, or gas.

5. **Radioactive Tracer Survey**
A radioactive tracer survey is commonly used to test the mechanical integrity of an injection well by detecting the movement of fluids tagged with a tracer. If mechanical integrity is compromised, the tracer fluid will be observed to split and travel in different directions. This survey is based on the presence of liquid in the wellbore; as such, it has minimal applicability to gas storage wells.
6. **Spinner Survey**
Spinner surveys make use of bladed spinners to measure the velocity of fluid flow in a well and are typically used in fluid injection wells or oil/gas production wells. This survey is based on the presence of liquid in the wellbore; as such, it has minimal applicability to gas storage wells.

iv. **Corrosion Logging**

Corrosion is a natural chemical process that is almost impossible to prevent. Consequently, controlling and monitoring of corrosion rate is often the preferred approach to managing corrosion. It is of concern throughout the life of the well and therefore must be monitored throughout the life of the well. There are several general categories of corrosion:

1. **Electromechanical:** includes crevice/pitting and stray current corrosion.
2. **Chemical:** hydrogen sulfide, polysulfide, sulfur, carbon dioxide, strong acid, concentrated brine, and biologically-influenced corrosion.
3. **Mechanical and mechanical/corrosive effects:** cavitation, erosion, corrosion fatigue, sulfide stress corrosion, chloride stress cracking, embrittlement and stress corrosion cracking.

The tools/techniques used for corrosion monitoring include:

1. **Multi-Finger Caliper Log:** Caliper feelers on the logging tool deflect as the tool is run through the casing. This deflection of each feeler is used to identify where corrosion is occurring and the percentage of casing wall thickness that has been lost to corrosion.
2. **The CPET, or Corrosion Rate log,** measures potential differences and casing resistance between electrode pairs to calculate radial current density from which the casing corrosion rate is computed.
3. **Electromagnetic Casing Inspection Log:** The Electromagnetic Pipe Scanner Tool measures the average thickness of the casing pipe and also discriminates between damage on the inside of the casing from damage on the outside. The Electromagnetic Pipe Scanner can be run inside tubing.
4. **Magnetic Flux Leakage Tool:** This tool induces a magnetic field and then measures perturbations in that field resulting from variations in the thickness of the casing.
5. **USIT and Ultrasonic Casing Imager:** Both tools use pulse-echo ultrasonic energy to reflect off of and resonate within the casing wall. Frequency analysis of the resonant signal allows computation to determine the thickness of the casing. In turn, the internal radius and computed thickness allows an assessment of both internal and external loss of original casing thickness.

v. **Additional Information**

1. An assessment of mechanical integrity should also include a thorough geologic review and evaluation of potential migration pathways. All available open-hole

geophysical logs and mud logs as well as drilling records should be evaluated with particular attention paid to the occurrence of gas shows above the gas storage reservoir as well as zones with potential for high transmissivity. Potential gas sources and pathways include but are not limited to the following:

- a. Shallow gas-bearing zones: Natural gas can occur naturally in shallow near-surface zones. Therefore, the presence of shallow gas would not necessarily indicate a breach in the integrity of a gas storage reservoir at greater depths.
- b. Coal seams and underground coal mines: Methane gas naturally occurs in coal seams and underground coal mines. Therefore, the presence of natural gas in and near coal seams would not necessarily indicate a breach in the integrity of a gas storage reservoir at greater depths.
- c. Legacy oil and gas wells: Active and abandoned oil and gas wells proximal to gas storage reservoirs may act as conduits for natural gas to migrate into other strata including shallow aquifers. Legacy oil and gas wells, particularly historic wells that were drilled, completed, and plugged and/or abandoned prior to implementation of modern drilling techniques, well construction, cementing, and plugging practices, can present avenues for gas migration from gas storage reservoirs.

f. Evaluating Mechanical Integrity Testing

A complete assessment of mechanical integrity requires a holistic, risk based approach. This holistic approach should use a combination of investigative procedures to assess mechanical integrity and draw results based on an overall well evaluation analysis, as opposed to focusing on one single test or well log, and should consider risks of testing and of testing histories. No single test or log can provide a proper determination of mechanical integrity. Routine monitoring, testing, and record keeping for the life a well can ensure mechanical integrity objectives are met.

Chapter 7

Reservoir Integrity

Introduction

Reservoir integrity is defined by the geologic conditions for safe operation of UGS facilities beyond the wellbore. It specifies the volume, operating pressure, and integrity of the gas storage reservoir or cavern. Likely risk points for gas leakage are breaches of vertical and lateral confinement caused by man-made penetrations (wells), and naturally occurring faults, fractures, confining zone/caprock sequence, and stratigraphy. This chapter includes an overview of factors affecting reservoir or cavern integrity. Regulatory and risk management elements, including API and International Organization for Standardization (ISO) recommendations, are discussed. The important issue of reservoir monitoring is considered in Chapter 9.

Major Issues and Concerns

Although wells constitute a fundamental risk element for product loss, the geological and geomechanical integrity of the reservoir itself is also of primary concern (30). Hydrocarbons (gas and liquids) can escape confinement from their intended subsurface zone by means of multiple mechanisms including accessing faults and fracture sets (31) (32), failure of confining zone (caprock) sequences, and structural spill points. Failures of reservoir integrity and migration of gas and liquids are well documented for all main types of gas storage facilities (depleted oil and gas fields, aquifers, and caverns), along with storage in abandoned mines or purpose-built mined-rock caverns (33) (34) (35) .

Storage operators should be aware that, while a reservoir being operated as a production field may have sufficient isolation from adjacent production fields, when operated as a storage field there may be communication with those adjacent fields due to the significant pressure differentials, particularly with boundaries with spill point(s) or boundaries consisting of stratigraphic trapping mechanisms, i.e. porosity and permeability pinch outs. Similarly, a dry hole or observation well drilled on the perimeter of a field during the field's production era may not be "dry" during the field's storage era. The operator should also take into consideration during the field's design that operating above the discovery pressure may, depending on the field's specific characteristics, increase the risk of communication and gas movement.

Risk registers can be assessed and mitigative practices developed in the oil and gas (36), geothermal (37), and carbon dioxide sequestration (38) (39) (40) (41) industries. Standard practices for risk management include multiple-barrier models such as bowties (diagrams used to analyze risks and responses) (42) (43) and workflows that include well integrity, reservoir integrity, and operational/organizational elements. Design of monitoring programs to ensure reservoir integrity can be informed by analytical and computational reservoir and cavern models and regular assessments of the results.

Main Take-Aways

- Gas or liquids can leak or move from an underground storage facility of any type, if reservoir or cavern integrity is compromised, even when well integrity is maintained.
- Geologic and geomechanical characterization of storage reservoirs and cavern scan identify applicable risk elements for potential gas or liquid migration including faults, fracture sets, confining zone/caprock sequence failure, and structural spill points.

- Based on reviews of publically available literature and data, the frequency of gas migration or leakage from UGS facilities is generally very small. The lowest frequency is for solution-mined caverns in salt and the largest for depleted hydrocarbon formations.
- This is likely because such depleted formations may have older wellbores that were converted from production to storage.
- Risk mitigation should include management of reservoir and cavern pressures to minimize the risk of confining zone/caprock sequence failure.
- Risk management programs that include reservoir and cavern integrity issues should address the goals of available standards (such as API and ISO) and Federal legislation (PIPES Act of 2016).

Reservoir Integrity

a. Relevance of Reservoir Integrity to Underground Gas Storage

According to data from the U.S. Energy Information Administration (EIA), and shown in Figure 7-1, the majority (329, or 79 percent) of the 415 natural gas storage facilities in the U.S. (data as of 2015) utilize depleted oil and gas fields; 47 (11 percent) occupy depleted aquifers, and 39 (9 percent) are in mined salt caverns. Porosity storage then represents 91 percent of UGS fields, with solution-mined salt caverns comprising the remainder. The values compiled by EIA and noted here do not include approximately 70 additional facilities developed in mined hard-rock caverns such as coal mines that store LPGs such as propane.

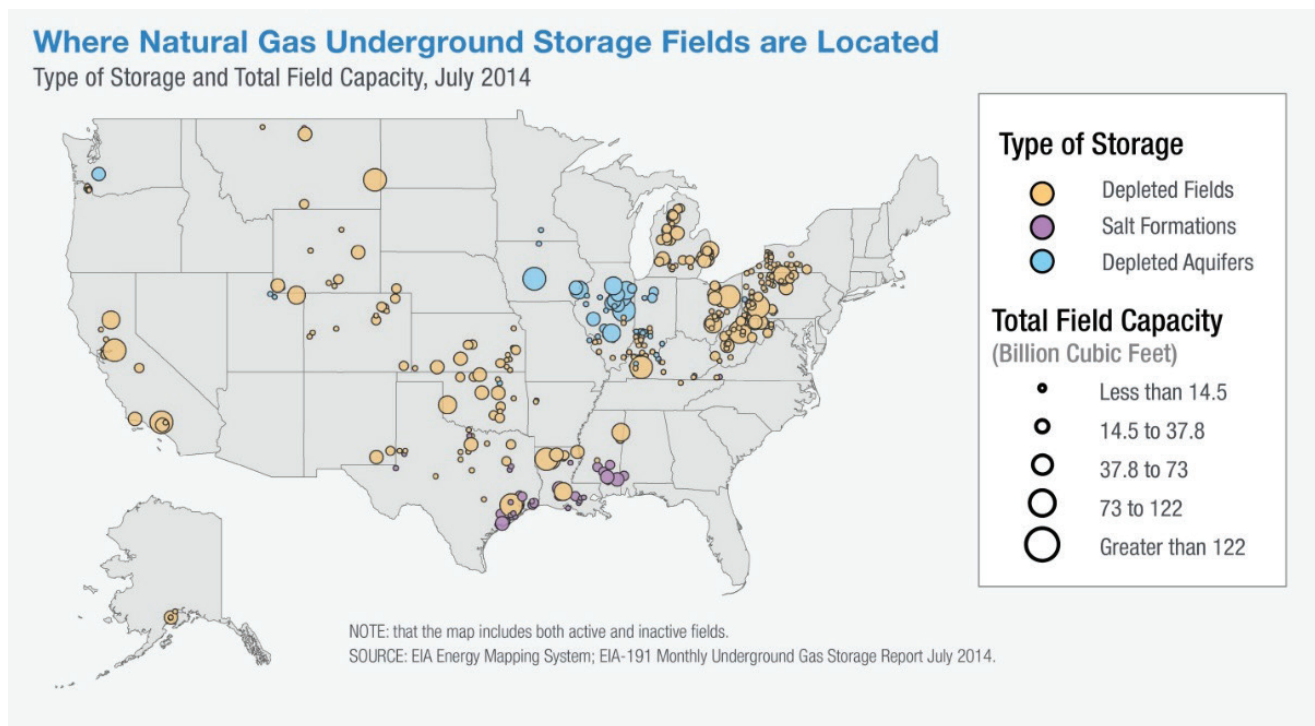

Figure 7-1 Geographic locations of Underground Storage facilities in the U.S.
Source: U.S. EIA www.eia.gov

Many examples are available in the literature that document migration of gas and liquids from their intended subsurface zone, even when wellbore integrity is maintained. These have been compiled and discussed by Evans and Folga et al. with additional events noted in this chapter. Although loss of well integrity is the primary cause of gas or liquid leakage events in the U.S. and worldwide for depleted oil and gas fields, loss of subsurface integrity is the dominant cause for depleted aquifer fields, salt cavern fields, and mined cavern fields.

The first use of abandoned mines for hydrocarbon storage (44) was in Sweden in 1947-1950 (20). A worldwide survey of underground mines repurposed for oil and gas storage by Peila and Pelizza (45) lists eight such mines globally, including six mines in the U.S., that were used for petroleum storage as of 1995 (their table 4). Of those eight mines, only three (one in the US (the Leyden mine and two in Belgium) were used to store gas according to Lu. At least five LPG storage facilities located in mined caverns were reported separately from Ohio alone, with leakage reported from one of these in 2013 (46). A report to the USDOE in 1998 (47) cited from an unpublished earlier study that a total of 1,122 UGS caverns were in operation in the U.S. for LPG as of 1991; of these, 70 were in hard rock caverns and 1,052 were in salt caverns. The Leyden storage facility northwest of Denver, Colorado utilized an abandoned coal mine that was in operation until 1950 (48).

Mined rock caverns are often at shallow depths below the ground surface, unlined, have depths exceeding about 150 feet, and typically utilize hydrodynamic containment (water curtains) (49) approaches when used to store oil and gas. (20) General guidance for natural gas and especially LPG storage in mined rock caverns is given by IOGCC (2) which emphasizes the role of mitigating limitations in the geology (such as fracturing or pillar strength) to promote safe operation of these facilities. Subsidence of the ground above mined caverns may promote an increased risk of product leakage and needs to be monitored and managed for this type of storage facility.

Of the 415 natural gas storage facilities in the U.S. (3), 74, or 15 percent, have experienced some type of product leak (liquid or gas) at some point in their operational life-cycle through 2005. (33) Following studies by Papanikolaou et al. (54) and Folga et al. (50) the approximate average incident frequency estimates for underground natural gas storage are listed and compared in Table 7-1. (After Schultz) (61) The values from the latter two studies combine different degrees of severity and therefore overestimate the rates of significant leakage events, such as those with fatalities and/ or property damage.

The values listed in Table 7-1 suggest that the frequency of leakage (in the subsurface) from all types of underground natural gas storage facilities in the U.S. ranges between approximately:

- 8.4×10^{-4} /facility/year, or once in about 1,192 facility years (54);
- 6.2×10^{-3} /facility/year, or once in about 161 facility years (50), which incorporates incidents through 2016 but uses facility years and well-year values from dating from approximately 2005); and
- 5.1×10^{-3} /facility/year, or once in about 197 facility years (50) with facility years and well-years estimated for 2016, the date of their study).

Correspondingly, the frequency of an incident involving a loss of well integrity at all types of underground natural gas storage facilities in the US ranges between approximately:

- 1.0×10^{-5} /well/year, or once in about 98,943 well-years of well operation (which incorporates incidents through 2016 but uses facility years and well-year values from dating from approximately 2005); (50) and

Facility Type	Cause	Leakage frequency, /facility/year		Leakage frequency from well-integrity loss,/well/year	
		Papanikolau et al. ¹	Folga et al. ²	Papanikolau et al. ¹	Folga et al. ²
Depleted oil and gas field	Well integrity	5.1 x 10 ⁻³	6.9 x 10 ⁻⁴ to 5.6 x 10 ⁻⁴	2.1 x 10 ⁻⁵	1.8 x 10 ⁻⁵ to 9.8 x 10 ⁻⁶
	Subsurface integrity		1.6 x 10 ⁻³ to 1.3 x 10 ⁻³		
	Operations		1.1 x 10 ⁻³ to 8.9 x 10 ⁻⁴		
Aquifer	Well integrity		9.9 x 10 ⁻⁵ to 8.1 x 10 ⁻⁵		2.5 x 10 ⁻⁶ to 1.4 x 10 ⁻⁶
	Subsurface integrity		1.6 x 10 ⁻³ to 1.3 x 10 ⁻³		
	Operations		1.5 x 10 ⁻⁴ to 1.2 x 10 ⁻⁴		
Salt cavern	Well integrity		3.9 x 10 ⁻⁴ to 3.2 x 10 ⁻⁴		1.0 x 10 ⁻⁵ to 5.6 x 10 ⁻⁶
	Subsurface integrity		2.5 x 10 ⁻⁴ to 2.0 x 10 ⁻⁴		
	Operations		3.5 x 10 ⁻⁴ to 2.8 x 10 ⁻⁴		

Table 7-1: Migration frequency from underground natural gas storage facilities

(1) Incidents were not broken out into separate causes or degrees of severity

(2) First value listed uses facility year and well-year frequencies from 2005 (54); second value listed uses estimated frequencies through 2016.

- 5.6 x 10⁻⁶ /well/year, or once in about 178,041 well-years of well operation (with facility years and well-years estimated for 2016). (50)

The data in Table 7-1 and summarized above confirm that solution-mined salt cavern storage is the least likely to leak (e.g., (51)), with aquifer storage having a greater average leakage frequency. Many UGS facilities in the U.S. have been operated for about a century and their average leakage rate is orders of magnitude smaller leakage rates of above-ground facilities such as tanks and pipelines. (33) In general, loss of well integrity is the primary factor in UGS leakage events with failures of subsurface integrity and operations being important secondary contributors.

Leakage events from UGS facilities have occurred from a number of causes (Table 7.1). Many can be related to a loss of well integrity, whereas others can be attributed to a loss of subsurface integrity (such as confining zone/caprock sequence failure, salt movement, or roof collapse) or operations (for example, procedures not followed). Many events are related to multiple causes and not all leakage events can be attributed solely to a loss of well integrity. In many cases the facilities were operated according to established guidelines, while at others operators failed to follow procedures. In all cases the risk of leakage events could potentially be reduced by improved guidelines for wells, geologic characterization, and operations.

Bruno et al. (52) showed that 22 leakage events from a total of approximately 485 porosity-storage facilities worldwide could be attributed to gas migration through the confining zone/caprock sequence, corresponding to about 10 percent of all reported migration events investigated in their study. Of these, half were due solely to failure of the confining zone/caprock sequence itself, a quarter were due solely to undetected or incorrectly characterized faults or fractures in the sequence, and the remaining quarter were due to a combination of confining zone/caprock sequence failure and seal bypass mechanisms. Aquifer storage accounted for about 10 percent of the worldwide total (but more than 31 percent of U.S. facilities; Table 7.1) but 65 percent of those 22 confining zone/caprock sequence-failure events.

The values noted in this chapter were computed as simple averages, following prior work in the literature on incident frequency (e.g., [(54) (55) (50)]). More robust methods such as those described by Hubbard (56) may lead to different probabilities or frequencies of facility and well leakage rates, and a corresponding difference in risk, for UGS facilities. For example, depending on the actual distribution of events and their magnitudes, the average frequency may overestimate the median, leading to an underestimate of the frequency of occurrence of large-magnitude events and a corresponding increase in risk (and decrease in time interval between them) for those larger events.

The underground storage of LPG in hard rock caverns is based on a principle of natural hydraulic containment, which involves keeping the hydrostatic pressure of the groundwater in the host rock higher than the vapor pressure of the stored product. (2) Reservoir integrity must be evaluated throughout the operations by: (2)

- Checking the stability of the cavern by continuous surveillance of acoustic emissions (seismic monitoring);
- Periodic subsidence monitoring;
- Permanent monitoring of the hydrogeological system through observations wells equipped with piezometers; and
- Ensuring that hydrogeological conditions necessary for the hydrodynamic containment of the stored product are maintained at all times.

b. Guidance from Existing Standards

Risk mechanisms and mitigation strategies for reservoir and cavern integrity are discussed in several applicable standards, including API RP 1170, 1171, and ISO 55000. (57) Risk mechanisms and mitigation strategies are listed in Table 2 of API RP 1171. Previous guidance for regulators produced by IOGCC is also incorporated into this chapter. (11)

ISO 55000 is an international standard for asset management. (57) It replaced Publicly Available Standard (PAS) 55, a 28-point checklist of requirements developed in 2004 for effective physical asset management in 2015. The PAS and ISO standards are currently being used by at least one U.S. public utility company that operates UGS facilities. (58)

API RP 1170 was developed in 2015 to provide recommendations for salt cavern facilities (cavern storage) used for natural gas storage service and covers facility geomechanical assessments, cavern well drilling and completion design, and solution mining techniques and operations, including monitoring and maintenance practices. API RP 1170 essentially updated and consolidated similar documents for UGS in solution-mined salt caverns published by the API, including API RP 1114 *Recommended Practice for the Design of Solution-mined Underground Storage Facilities* (13) (59) and API RP 1115 on *Operation of Solution-Mined Underground Storage Facilities*. (60) API RP 1171 is a new RP for natural gas storage in porous formations. (10)

Tables 1 and 2 in API RP 1171 list a set of risks and mitigation strategies for porosity storage of natural gas. Taken together, these tables resemble a bowtie diagram correlating risks (their Table 1) and mitigations (their Table 2). There is no corresponding set of risks or mitigations for natural gas storage in salt rock in API RP 1170.

There are three main groups of risk areas identified for porosity storage in API RP 1171, with several subcategories, as listed here:

- i. Surface
 - 1. Third-party damage
 - a. Surface encroachment
 - b. Intentional/unintentional damage
 - 2. Outside force: natural causes such as weather-related or ground movement
- ii. Reservoir
 - 1. Third-party damage
 - a. Drilling, completion, and workover activities
 - b. Production, injection, or disposal operations
 - 2. Geologic uncertainty
 - a. Extent of reservoir boundary
 - b. Expansion, contraction, and migration of storage gas
 - c. Failure of caprock
 - 3. Contamination of storage reservoir by foreign fluids; wellbore damage or corrosion
- iii. Wells
 - 1. Well integrity (corrosion, material defects, erosion, equipment failure, annular flow)
 - 2. Design
 - 3. Operations and maintenance
 - 4. Intervention
 - 5. Third-party damage
 - 6. Outside force: natural causes such as weather-related or ground movement

c. Risks and Mitigation Strategies in Underground Facilities

Reservoir integrity issues may be categorized by considering wellbore integrity and subsurface integrity as separate but interacting categories. (61) Gas or liquids may migrate out of their intended zones even if wellbore integrity is maintained due to unforeseen pathways in the subsurface, such as confining zone/caprock sequence failure or seal-bypass events above a producing reservoir. Based on experience with producing oil and gas and carbon dioxide sequestration fields (62), some of the risk factors that might be considered in subsurface integrity assessments for underground gas and liquids storage include:

- i. Over-pressuring relative to formation or confining zone/ caprock sequence strength;
 - ii. Frictional stability of major faults in a compartmentalized reservoir;
-

- iii. Availability of conduits such as faults, fractures, and stratigraphy that might connect to freshwater aquifers, storage horizons, or the ground surface; and
- iv. Exceedance of specified limits on injected volumes, or pressure in the storage facility, dependent upon settings and maintenance of surface control equipment, such as safety valves.

As far as geologic or geomechanical risks are concerned; only confining zone/caprock sequence integrity was noted in API RP 1171. Additional risk elements related to the geology include stress state determination, faults, and potential seal-bypass mechanisms.

Mitigation of risks of fluid migration or leakage (through the confining zone/caprock sequence) falls into several categories.

- i. Mitigation strategies for geologic uncertainty of the reservoir, following API RP 1171, include:
 - 1. Collect and review regional data;
 - 2. Collect new data from nearby wells;
 - 3. Acquire new data (seismic, new wells, gas tracer);
 - 4. Establish a buffer zone (vertically and horizontally) for evaluation the regulating or governing agency;
 - 5. Conduct semiannual tests for inventory verification;
 - 6. Acquire property and mineral rights;
 - 7. Establish observation wells;
 - 8. Inspect older wells that were used in production of hydrocarbons, injection wells previously used for pressure maintenance or stimulation, or converted to storage; and
 - 9. Inspect plugged and abandoned wells, review records for all wells.
- ii. Mitigation strategies for confining zone/caprock sequence failure, following Bruno et al. (52), involve three areas of risk: (a) the mechanical state, including stress state, reservoir pressure, and the presence of faults that cut into the confining zone/caprock sequence from the reservoir; (b) the confining zone/caprock sequence-reservoir system, including extent, thickness, and depth of reservoir and confining zone/caprock sequence, plus confining zone/caprock sequence characterization; and (c) operations, including well density and number of cased vs. uncased wells. These strategies apply to porosity storage and to salt storage. The basic mitigation strategies developed by Bruno et al (2014) to reduce the likelihood of confining zone/caprock sequence failure, and thus fluid movement, include:
 - 1. Reservoir pressure: must be less than the fracture pressure (for normal and strike-slip faulting regimes) and critical pressure of the fault reactivation of the confining zone/caprock sequence;
 - 2. Caprock characterization: confining zone/caprock sequences that are thicker than about 30 meters, strong, low permeability values, homogeneous, and composed of multiple intercalated sealing lithologies provide the safest barrier zones against fluid movement from the reservoir;
 - 3. Faults and natural seismicity (63): confining zone/caprock sequences that are cut by faults, especially those which are close to wellbores, pose greater risk for fluid movement than those with few to no faults. UGS in seismically quieter areas have

- a lower likelihood for faults to be reactivated under fluid injection/withdrawal conditions, permitting larger values of reservoir pressure; and
- 4. Reservoir thickness and depth: thicker and deeper reservoirs are safer than shallower ones for confining zone/caprock sequence integrity since these impose smaller stress and displacement changes onto confining zone/caprock sequence and overburden.

Pre-existing or abandoned wellbores including previously pressurized or depleted areas, and previously generated hydraulic fractures should also be considered as risk elements.

In the industry, fluid leakage through the confining zone/caprock sequence is usually mitigated by reducing reservoir pressures and, in extreme cases, closing the storage facility, as damaged confining zone/caprock sequence in general cannot be repaired. Geologic, geophysical, and geomechanical characterization of a UGS site that can inform the mitigation strategies provide the basis for assessing and potentially reducing the degree of subsurface integrity risk.

d. Rock Mechanics Aspects of Geologic Storage

As described above, there are in general four types of geologic structures used for UGS: depleted oil and gas formations, aquifers, solution-mined caverns in salt formations, and mechanically mined rock formations. The rock-mechanical properties of each are somewhat different, and these different properties require consideration for gas storage operation, as well as for the development of regulations to ensure reliable operation and safety. Depleted oil and gas formations and water aquifers are of similar rock type and will be addressed together as porosity storage. Salt formations used for solution-mined salt caverns have properties quite different from porosity storage rocks in that the porosity and permeability of salt are negligible in comparison. Finally, mechanically constructed mines, such as in coal or salt, are considered as a distinct fourth type of UGS facility.

Two of the principal properties of rock that are of vital importance to underground storage of natural gas are porosity and permeability. These concepts are defined as follows and illustrated in Figure 7-2:

Porosity – Rock is composed of solid materials, grains, and pore space, as illustrated in Figure 7-2. In the subsurface, the pore space is filled with gas (e.g., air or natural gas) or liquids (e.g., oil or water). For example, the pore space in typical oil and gas formations is filled with pressurized oil, natural gas, and brackish/ saline water. The pore space fluids are pressurized due to depositional and geochemical processes. Porosity is the ratio of the pore space to the total volume of rock, usually expressed as a percentage. For the purposes of UGS, higher porosity means greater volume of gas that can be stored. Table 7.2 summarizes the porosity of some rock types.

Permeability – Permeability is the measure of the ability of a fluid to flow through rock. For a rock to be permeable, it must have not only pores, but the pores must be connected to provide a path for flow. This property is also indicated in Figure 7-2.

With regard to Table 7-2 and UGS, there are two important points to be considered with regard to porosity and permeability. First, porosity governs the volume of gas or liquid that can be stored in a porous rock formation. The total volume of a porous rock formation that can be used for storage is dependent on the thickness of the formation, its lateral extent, and the deformability (i.e., compressibility) of the formation. Sandstone has an obvious advantage over salt for porous rock storage, based on porosity. On the other hand, salt is soluble in water, and sand is not. So, to create volume in salt for storage, a well is drilled into

Rock type	Porosity - %	Permeability - Darcy
Sandstone	10 – 30	0.1 – 5.0
Salt	0.01 – 1.0	10^{-22}

Table 7-2: Typical ranges of porosity and permeability of UGS rocks (64)

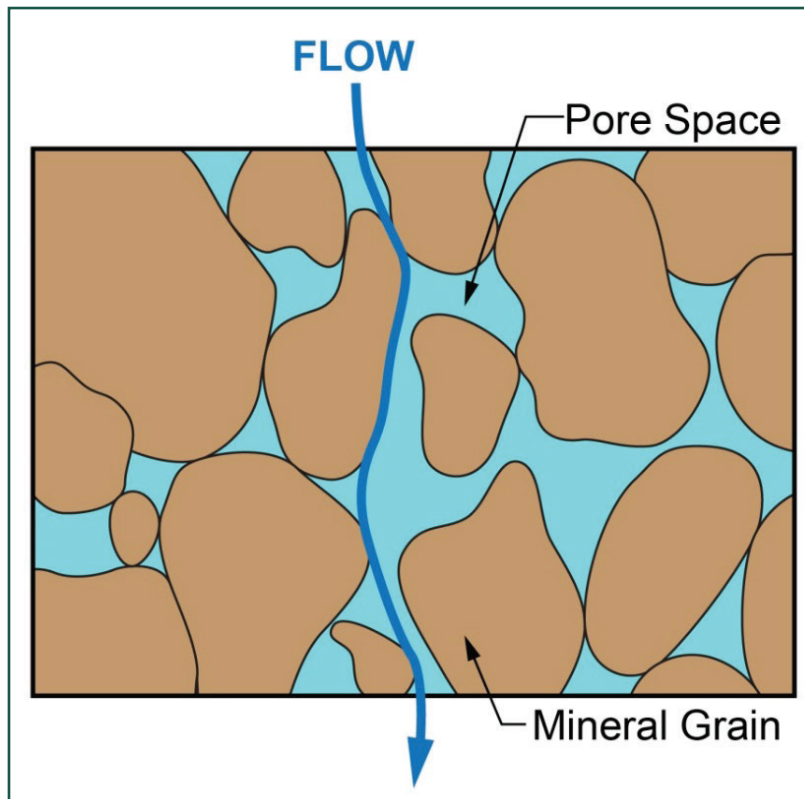

Figure 7-2: Cross section of porous and permeable rock

a salt formation, concentric tubing strings are installed in the wellbore, freshwater is pumped into the inner tubing, and brine is produced from the annular space between the concentric tubing strings. This process is called solution mining. Large caverns can be created to store gas or hydrocarbon fluids using solution mining methods, as much as 2,000 feet tall and 350 feet in diameter.

Second, permeability governs how easily gas and liquid can flow through a rock formation. Sandstone has a much greater permeability than salt (assuming a small to modest degree of diagenesis and cementation between the grains), so gas can flow or migrate very quickly and for large distances in sandstone. On the other hand, since salt has such a small permeability (i.e., it is almost impermeable), gas cannot flow through it and thus salt can be used to trap gas in a cavern.

Though salt may be considered to be nearly impermeable, and thus ideal for hydrocarbon storage, it is known that salt domes or beds may not be perfectly homogeneous. Salt bodies may include discrete thin zones of higher permeability than the bulk of the salt body, such as splines, clay layers, and faults. Thus, in preparation for hydrocarbon storage design, careful geological investigations should be conducted.

To give some physical meaning to the storage space comparing solution-mined caverns in salt and sandstone depleted oil and gas reservoirs, consider the results of some realistic examples. An ideally shaped cylindrical solution-mined cavern could be 2,000 feet tall and 300 feet in diameter, which results in a storage volume of 141,371,669 cubic feet. Now, considering the pore volume of the same cylinder 2,000 feet tall and 300 feet, but in sandstone with 20 percent porosity, the storage volume would be only 28,274,334 cubic feet. But, a hypothetical depleted sandstone formation 300 feet thick, but with a diameter of 2,000 feet would have a pore volume for storage of 188,495,559 cubic feet. In fact, the idealized diameter of a typical depleted formation may be many times larger than 2,000 feet, and in fact may sometimes be as large as 20,000 to 40,000 acres in size; so depleted formations can have a much greater volume than a single cavern.

Two important operational volumes in UGS of gas are the working and cushion volumes. Cushion gas, or pad gas, is the volume of gas that must remain in a cavern or in the pore space at all times. The reservoir pressure support provided by the cushion gas serves two purposes. First, the pressure support permits the storage field to have deliverability high enough to meet its design day market requirements fairly late into the withdrawal season. Second, cushion gas also provides enough pressure support for average day deliverability to be high enough to permit the working gas volume to be withdrawn in a relatively short period of time, i.e. typically the 5-month winter season for most reservoir and aquifer storage and shorter periods of time for salt cavern storage. The volume of cushion gas makes it easier to withdraw gas during withdrawal periods. Cushion gas is also required to maintain the structural stability of a solution-mined cavern, as will be explained below. The working gas volume is the volume that is storage, which is injected and withdrawn over time.

e. Pore Storage Considerations in Depleted Formations

The advantages and disadvantages of porous rock formations, such as depleted oil and gas reservoirs and aquifers, are summarized in this section.

- i. Reservoir characteristics
A schematic cross section of a depleted oil and gas formation is shown in Figure 7-3. Depleted reservoirs originally contained and produced oil, natural gas or both. The reservoir rock itself must have sufficient porosity and permeability to allow the gas to be easily pumped into the rock and migrate through the reservoir in the first place, and the easily allow withdrawal of the stored gas when needed. Injection and withdrawal cycles can take place as many as five times per year. Higher quality depleted reservoirs, those with high porosity and permeability, also have lower cushion gas requirements. Depleted oil and gas formations are generally the least expensive to develop, operate and maintain.

The factors that determine whether or not a depleted reservoir will make a suitable storage facility are both geographic and geologic. Geographically, depleted reservoirs must be in a location with access to a customer market, either residential, commercial, industrial, or a combination. The facility should also be close to pipeline and transmission infrastructure.

- ii. Vertical and lateral confinement
To ensure containment within a depleted reservoir (a requirement for any gas storage facility) there must be an impermeable cap rock/ confining zone above and either structural or stratigraphic containment on the flanks of the formation. A competent overlying cap rock (the confining zone/caprock sequence) is required to seal the storage formation

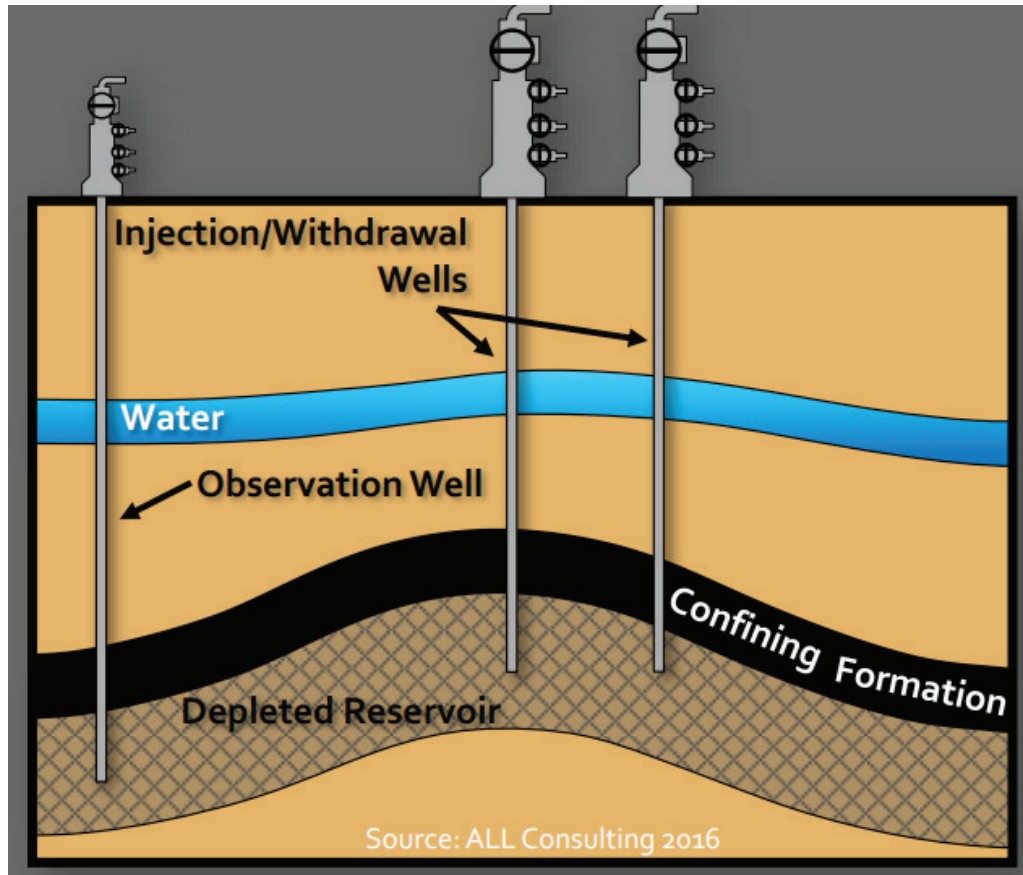

Figure 7-3: Depleted hydrocarbon formation storage

Source: http://www.gwpc.org/sites/default/files/event-sessions/Alleman_Nathan.pdf

and prevent vertical fluid movement. Preventing or minimizing horizontal fluid movement can be a more difficult challenge, particularly for stratigraphic trap type fields. Monitor wells are placed strategically at the perimeter of the field, with the pressure monitored and the composition of the gas checked from samples. In some cases, faults might be considered geological horizontal barriers, but faults are often not always impermeable, (65) and may be activated as leakage pathways under sufficiently elevated stresses or reservoir pressures. In other cases, geological pinch-outs can serve as a boundary.

iii. Operating pressure design

In order to maintain pressure in depleted reservoirs, up to about 50 percent of the natural gas in the formation must be kept as cushion gas. Depleted natural gas reservoirs require less injected cushion gas because some native gas still remains. Operating pressures are customarily dictated by the fracture strength of the formation rock and the pressure integrity of the casing shoe. Gas migration may also be a consideration in establishing the maximum storage pressure, since the rate of gas flow in a porous and permeable formation increases with increasing storage pressure.

The MAOP should be determined after a thorough analysis of a variety of factors including the rock fracture strength (or the fracture gradient) and critical frictional strength of any nearby faults at the bottomhole location, the water gradient, initial formation pressure, caprock seal integrity, geomechanical testing, and other considerations. The pressure

required to inject intended gas volumes, particularly at total inventory, should be limited by reservoir rock strength, well integrity, wellheads, piping, or associated surface facilities.

The minimum reservoir pressure should not be less than historic minimum operating pressure, unless reservoir geomechanical competency can be demonstrated. The impacts of intended minimum reservoir pressure should be accounted for in a regional review of the geologic formation as it relates to geomechanical stress, subsidence, reservoir liquid vertical influx as gas is withdrawn, surface facility gas cleaning and liquid handling, and liquid disposal, all of which affect the maximum cycling capacity of the storage field and can impact mechanical integrity of the facilities. (10)

f. Pore Storage Considerations in Aquifers

As summarized in API RP 1171, (10) if depleted hydrocarbon reservoirs are not present in a geographic area where storage is desired, aquifers exhibiting the qualities of a hydrocarbon reservoir may be utilized. Aquifer reservoir storage dates back to 1946. (10) As of 2015, there were 51 operating aquifer storage reservoirs in the U.S. and Canada representing over 2,300 reservoir-years of operation, with a maximum inventory capacity of 1.3 trillion cubic feet, accessed and monitored by more than 2,600 wells.

Aquifer reservoirs are similar to depleted hydrocarbon reservoirs in terms of the nature of the porous rock media used to contain the gas and the methodology for assessing the reservoir. The storage suitability of an aquifer reservoir requires careful investigation on an individual basis, using a number of means to evaluate reservoir integrity, well integrity, and existing fluid chemistry.

i. Reservoir characteristics

As shown schematically in Figure 7-4, aquifer storage is similar in many ways to depleted hydrocarbon storage. Aquifers are underground porous and permeable rock formations that act as natural water reservoirs. Some aquifers can be used as natural gas storage facilities. As they are more expensive to develop than depleted reservoirs, these types of storage facilities are usually used only in areas where there are no nearby depleted reservoirs. Traditionally, because of the requirement to fill slowly while pushing water back, these facilities are operated with a single winter withdrawal period.

Aquifers can be the most challenging and most expensive type of natural gas storage facility for a number of reasons. First, the geological characteristics of aquifer formations are not as thoroughly understood when compared with depleted reservoirs because of lack of history that includes site characterization (e.g. drilling and production logs). A significant amount of time and money goes into discovering the geological characteristics of an aquifer, and determining its suitability as a natural gas storage facility. Geophysical testing must be performed, similar to what is done for the exploration of potential natural gas formations. The area of the formation, the composition and porosity of the formation itself, and the existing formation pressure must all be characterized prior to development of the formation. In addition, the capacity of the reservoir is unknown, and may only be determined once the formation is further developed. Lastly, confining zone/caprock sequences that would promote gas containment may be of unacceptably poor quality (e.g., thin, fractured, or even absent; Bruno et al.). (52)

In aquifer formations, cushion gas requirements average about 70 percent of the total capacity and can be as high as 90 percent. While it is possible to extract cushion gas from depleted reservoirs, doing so from aquifer formations could have negative effects, including loss of effective permeability. As such, most of the cushion gas that is injected into any one aquifer formation may remain unrecoverable, even

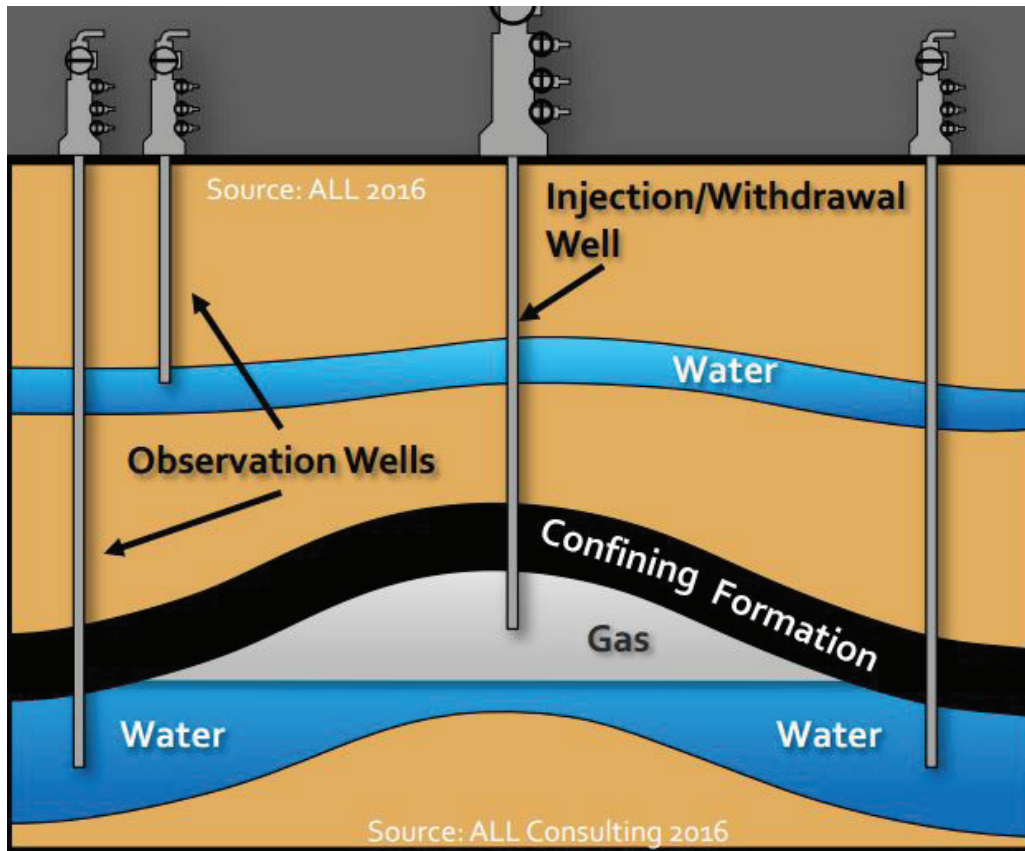

Figure 7-4: Aquifer storage

Source: http://www.gwpc.org/sites/default/files/event-sessions/Alleman_Nathan.pdf

after the storage facility is shut down. Most aquifer storage facilities were developed when the price of natural gas was low, meaning this cushion gas was not very expensive. When gas prices are higher, aquifer formations are increasingly expensive to develop.

- ii. Vertical and Lateral Confinement
The lateral and vertical confinement is essentially the same as depleted oil and gas formations. Vertical confinement may be more challenging in part because aquifers are generally shallower.
- iii. Operating Pressures
The basis for operating pressures for aquifer storage is essentially the same as for depleted hydrocarbon formation, since the rock type is usually similar (i.e. sandstone). Aquifers are generally shallower than depleted hydrocarbon formation, thus requiring some additional considerations. Aquifer storage reservoirs operate at pressures above and below the pressure of the water in the aquifer, resulting in potential water efflux and influx, and changing gas reservoir size. Therefore, semiannual surveys, which are essentially the summer and winter time frames, may not be effective in inventory assessment (some states, such as Louisiana, require quarterly assessments of solution-mined caverns). In addition, extended shut-in periods, whether at high or low inventory levels, result in changes in the reservoir volume that could be detrimental to the reservoir's operation. (10)

g. Salt Cavern Storage Considerations

Construction of the first solution-mined salt caverns in the U.S. created specifically for the storage of natural gas began in the Eminence Salt Dome in Mississippi in the late 1960s by Transcontinental Gas Pipe Line. (66)

i. Geological characteristics

As shown schematically in Figure 7-5, salt caverns are located in underground salt formations either in salt domes or in salt beds. The caverns are typically solution mined by injecting fresh water through a well drilled into the salt, dissolving the salt into brine with the fresh water and withdrawing the resulting brine for disposal in underground rock formations near the salt cavern. The produced brine is frequently used commercially as feedstock in chemicals manufacturing.

Essentially, salt caverns are formed out of existing salt deposits. These underground salt deposits may exist in two possible forms: salt domes and salt beds. Costs for salt dome-based caverns are typically lower than the development costs for bedded salt-based caverns; usually due to the size of the caverns (caverns in salt domes are typically larger than caverns in bedded salt).

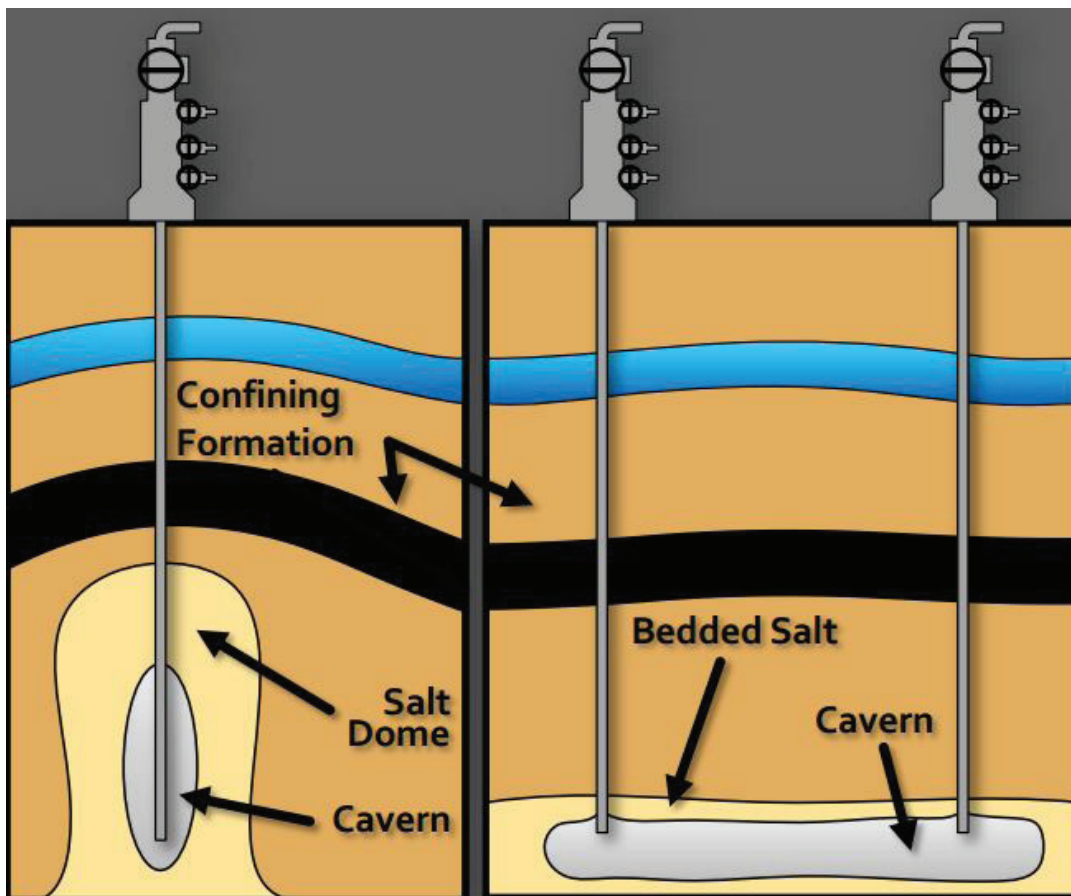

Figure 7-5: Solution mined caverns in salt dome (left) ; bedded salt formation (right)
 Source: http://www.gwpc.org/sites/default/files/event-sessions/Alleman_Nathan.pdf

Salt cavern storage facilities are primarily located along the U.S. Gulf Coast, as well as in the northern states. Salt cavern storage is well suited for peak load storage since the gas can be quickly withdrawn compared to depleted porous formations. Salt caverns can readily begin flowing gas on as little as one hour's notice, which is useful in emergency situations or during unexpected short term demand surges. There are significant cost and schedule advantages to using suitable existing caverns for gas storage rather than solution mining new caverns specifically designed for gas storage. As discussed earlier in this chapter, salt caverns are typically much smaller than depleted gas reservoirs and aquifers. Thus, salt caverns generally cannot hold the volume of gas necessary to meet base load storage requirements. However, deliverability from salt caverns is typically much higher than for either aquifers or depleted reservoirs, so caverns can accommodate more frequent withdrawal and injection cycles.

Salt domes: Salt domes are thick formations created from natural salt deposits that, over time, flow up through overlying sedimentary layers to form large dome-type structures. They can be as large as a mile in diameter, and 30,000 feet in height. Typically, salt domes used for natural gas storage are between 1,000 and 2,500 feet beneath the surface, although in certain circumstances they can exist much closer to the surface.

Salt beds: Bedded salts are shallower, thinner formations. These formations are usually no more than 1,000 feet in height and are commonly composed of multiple thin layers. Because salt beds are wide, thin formations, once a salt cavern is introduced they are more prone to deterioration, due to potential flexure of the roof of the mined cavern. (52)

ii. Vertical and lateral confinement

Lateral confinement of gas within a solution-mined cavern is governed by the low permeability of salt. Careful geological investigations are required, however, to determine the presence of anomalous high-permeability layers or stringers. Vertical migration is governed by the overlying cap rock, which may be composed of anhydrite, gypsum, and calcite cap above many salt domes that is formed by consolidation, cementation, and alteration of insoluble residue left by salt dissolution. In domal salts, which are created by the upward deformation of salt formations, the cap rock may be fractured, thus cap rock must be adequately characterized in detail, and a wellbore penetrating the cap rock may be difficult to cement efficiently. (52)

iii. Operating pressure design

As compared to reservoirs or aquifers, salt caverns offer high rates of injection and withdrawal relative to the amount of working gas capacity. The result is that the working gas capacity in salt caverns can be cycled many more times than either reservoirs or aquifers, typically in the range of 12 annual cycles of working gas capacity. Salt caverns also require less cushion gas; usually 20 percent to 30 percent of the facility's working gas volume, as compared to depleted formations.

The MAOP is based on the fracture pressure of the salt at the casing shoe. But geomechanical analysis should also be used as a basis for determining possible microfracturing of the salt under high cavern pressure.

The minimum pressure in a storage operation is dictated by the creep closure of the cavern. The minimum pressure is specified to minimize surface subsidence and creep closure. Creep closure and cavern roof deformation (sagging) can result in high stress and strain on wellbore casing strings, which should be considered in cavern operations, including long term shut in, operating cycles, and abandonment. (67)

iv. Geomechanical Modeling

Geomechanical modeling is the analytical or, numerical or computational modeling of geologic materials to predict and understand deformations and loads due to changes in stress or fluid pressure on rocks or soils. A rich literature exists on this topic. In the context of UGS, geomechanical modeling is used to assess the stability of caverns in solution-mined salt caverns, and the deformation of depleted formations and their caprock/confining zone sequences. Cyclic deformation and stresses during injection and withdrawal cycles can cause undesirable loads on wellbores, which can affect overall integrity of the storage system. Currently, there are no specific state regulations or requirements for geomechanical modeling of UGS facilities. PHMSA, however, has recently promulgated regulations on UGS which incorporate by reference API RP 1170 and API RP 1171, which may make geomechanical modeling of UGS facilities mandatory, at least regarding solution mined caverns in salt. Some considerations of geomechanical modeling of UGS include:

1. **Salt Cavern Storage Considerations:** Sections 5.4 and 5.5 of API RP 1170 address geomechanical site characterization and numerical modeling for gas storage in caverns solution mined in salt. Section 5.4 covers the types of core tests and their results that are recommended for characterizing the behavior of the salt, and the quantitative results recommended as input into numerical geomechanical models. Section 5.4 provides recommendations for numerical geomechanical modeling: *“The structural stability and geomechanical performance of natural gas storage caverns in salt should be assessed using numerical models that represent the geometries of the caverns, their development history and operating conditions during gas storage, the geologic structure around the caverns, the mechanical properties of the salt and nonsalt units, and the preexisting in-situ conditions. In particular, the numerical models should simulate the time-dependent creep deformation that is distinctive of rock salt and other evaporites.”* RP 1170 states that the geomechanical model should be of sufficient detail to produce results to judge the structural stability and mechanical integrity of a cavern during gas storage operations, such as cavern shape and size; cavern proximity to other caverns and the edge of the salt deposit; depths of casing seat, roof, and floor; wellbore and cavern roof design; minimum and maximum storage pressures and cycling; and estimation of surface subsidence.

API RP 1170 does not provide recommendations for the type of geomechanical method to be used, but in general the published literature includes the numerical approaches as explicit or implicit finite element methods, and the finite difference method. Whichever method is used, it is important that the method include a verified constitutive model for creep behavior of the salt (e.g. with values determined by the laboratory tests on salt from the cavern). An example of such geomechanical modeling for UGS in solution mined salt caverns, which includes references to other similar geomechanical methods, is given in Hilbert and Saraf. (67) Analysis for a bedded salt deposit is presented in Bruno. (52)

2. **Depleted hydrocarbon formations and aquifers:** API RP 1171 for gas storage in depleted hydrocarbon formations and aquifers does not include any recommendations for geomechanical modeling. Geomechanical modeling for storage in depleted formations may be considered to determine stresses on wellbores, potential shearing of wells due to slip on faults or at geologic unconformities, and surface subsidence or heave during injection and withdrawal cycles. For UGS in nonsalt porous rocks the methods and techniques are similar to the techniques used for reservoir modeling in the upstream oil and gas industry. An example of a geomechanical computational model for UGS can be found in Teatini et al. (68)

Chapter 8

Injection and Withdrawal Well Operations and Maintenance

Introduction

Gas storage wells and fields require proper operations, practices, and regular maintenance and assessments to ensure integrity and intended use throughout all stages of life – from start of initial testing, injection and withdrawal from storage, up to final plugging and abandonment. Since each gas storage field and its wells are different, general processes are covered here that apply across all fields and wells. Recently formulated and earlier documents covered proper operations practices and regular maintenance, and they are referenced here with additional suggestions.

Major Issues and Concerns

In porosity storage, gas storage wells often are converted former oil and gas producing wells, and whether converted or newly drilled and completed, these dedicated storage wells will have extended lives. Long-term well integrity and functionality depend upon proper field and well operations and maintenance, including changes in the reservoir, fluids, rates, stimulation, remedial work, offset drilling, and surface conditions and parameters. Essential continual monitoring of current conditions, and comparison versus designed and expected future conditions, will indicate the integrity and functionality issues during facility and well life. Accordingly, monitoring, access and control need to be implemented at all times and under all conditions.

LPG salt cavern storage wells have significant differences in operation compared to natural gas storage in porous reservoirs. LPG salt cavern storage well systems have a brine side and a product side to the operation. These systems are kept separate for safety and environmental considerations. Brine is injected into a tubing string to displace product out the annulus and when product is emplaced into the cavern, the displace brine is then retained and stored in surface impoundments or injected into another formation. The brine storage impoundments can be designed to prevent leakage which can result in contamination of the environment. Safety equipment such as gas separators directed to flares should be used to handle any LPG that enters the brine system. Gas detectors may also be deployed around the perimeter of the impoundment as an added safety feature. One should be concerned with the containment not only of the LPG, but also the brine.

Hard rock cavern storage relies on geomechanical stability which can be addressed by the appropriate geomechanical analysis techniques. (2) The main issues and concerns with hard rock cavern storage are:

- Roof collapse;
- Pillar collapse; and
- Surface subsidence.

Main Take-Aways

- Gas or liquids can leak or migrate from an underground storage facility of any type, if wellbore integrity is compromised, even when reservoir or cavern integrity is maintained.
- Well maintenance, operations, and well integrity can vary considerably between the different types of reservoirs.

- Well workovers and operations can be conducted to evaluate or restore functional mechanical integrity of a wellbore and should be accomplished to ensure well integrity.
- Periodic well integrity testing is an important tool for operators to assess the changing functional integrity of downhole and wellhead assets. Testing methods discussed are: annular pressure monitoring and casing inspection. Frequency of integrity re-assessment should be driven by the operator's risk assessment procedure as discussed in Chapter 3.
- Operators should establish standard operating procedures for well reporting, and compliance with State and Federal agencies.

Well Operation and Maintenance

a. Long Term Well Integrity

- i. API RP 1170 and API RP 1171 – Guidelines established in API RP 1170 and API RP 1171 may be used by gas storage operators wherever these API RP are applicable to natural gas storage wells and facilities.
- ii. Minimum and maximum operating pressure –
 1. Operators determine the maximum and minimum operating pressures each gas storage well and each gas storage facility component will be subjected to during the well or component lifetime. A starting point for maximum operating pressure analysis is a field's discovery pressure. If an operator chooses to operate the facility above the discovery pressure then additional reservoir and cap rock analyses are required to be able to justify safe operations at that pressure level. The minimum pressure should be established to meet minimum customer deliverability requirements, but in no case should the minimum pressure allow for detrimental subsidence or other integrity complications.
 2. The operating pressure range of each well and component, along with the gas pipeline system demands, should be used in each original design, re-design, and operational plan.
 3. Periodically, the operational plan should be reviewed and confirmed to be applicable to each well and component. During the operational plan review storage operators should ensure that operating pressures do not exceed the minimum and maximum operating pressure at storage well or wellhead.
 4. For salt or hard rock caverns, it is extremely important that the maximum operating pressure gradient remain below the fracture gradient to maintain reservoir or cavern integrity.
 5. When assessing field-wide risks, a probabilistic model is recommended where the risk can be quantified and maintained within acceptable limits as determined by physical limitations, regulations and industry standard practices.
- iii. Construction (See Chapter 5)
- iv. Workovers
 1. Major workovers typically include drilling rigs and/or service-type pulling units that operate in situations where the wellhead christmas tree is removed and wellbore is accessible for work. If the current wellhead assembly does not allow for workovers under pressure, the operator should consider installation of a

master shut-off valve or snubbing valve on the production casing for additional well control. Major workovers include:

- a) Running or pulling existing casing;
 - b) Drilling;
 - c) Running or pulling tubing; and
 - d) Casing repairs, including:
 - 1) Casing patches;
 - 2) Casing liners; and
 - 3) Remedial cementing;
 - e) Milling;
 - f) Fishing jobs;
 - g) Hydraulic fracturing; and
 - h) Re-completions.
2. Minor workovers typically are methods conducted through existing completions (whether the completion has tubing or not), that provide remedial and/or enhanced well operation. Minor workovers often are performed via workover rigs, coiled tubing and/or wireline methods, for a variety of purposes, including but not limited to:
- a) Downhole sensor work;
 - b) Wellbore stimulations (e.g., acid jobs, coil tubing cleanouts, etc.);
 - c) Casing integrity logs;
 - d) Perforating;
 - e) Subsurface safety valve work; and
 - f) Well cleanouts.
3. Operators should develop standard operating procedures addressing records retention and key records retained for the life of the storage field.
4. Operator staff and contractors should be appropriately trained for their assigned tasks and their competency should be periodically reviewed to ensure job proficiency
5. Protection of the public health, safety, property, and the environment must be taken into consideration when planning a workover. A blowout preventer and/or other well control methods are used.
6. Where appropriate the operator should evaluate and implement additional site security measures while well work is ongoing and equipment is on site.

b. Periodic Well Integrity Testing

i. Annular monitoring

1. The operator should monitor each well annulus that is not cemented to the surface by placing a valve on the wellhead, and the measurement device should have an isolating valve between it and the wellhead annulus, so the measurement device can be removed and/or changed safely and efficiently without disturbing the well operation. Some contributors to this report advocate for monitoring all annuli, regardless of whether they are cemented to surface, to identify potential cementing problems.
2. Annulus monitoring may be by simple visual analog dial measurements and/or digital remote sensing methods.
3. The operator may also consider the continuous monitoring of all annulus pressures, establishing SCADA limits and alarms.

ii. Casing inspection

1. Operators may use a variety of casing inspection methods and tools to ascertain an original baseline, and subsequent changes, in casing integrity and condition. A detailed list of these methods and tools are discussed in Table 6-1.

iii. Inspection and integrity testing frequencies

1. Frequency of casing inspection is based upon the operator's risk analysis for each field, area in the field, and well and should be included in the operator's field and well operating plan. Regulatory guidelines must also be taken under consideration.
2. The operator will integrate the latest casing inspection results with the design data for the well in addition to any prior inspection results as part of the current analysis. Significant changes in a well's condition or the remaining life of casing will be further investigated.

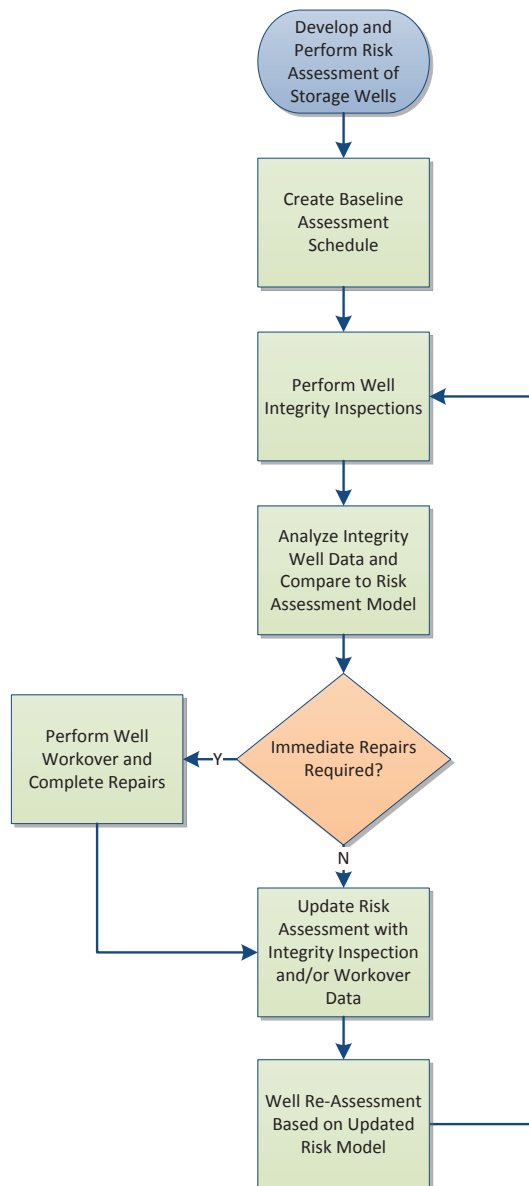

Figure 8-1: Flowchart of casing inspection frequencies based on risk assessment

3. Frequency of casing inspection is included in the operator's field and well operating plan, based upon the risk analysis in item 1 above. Regulatory guidelines must also be taken under consideration. The flowchart shown as Figure 8-1 can be utilized by regulatory agencies to determine if an operator's re-assessment schedules follow risk management principles and are reasonable:
 1. Based on operator's threat and risk assessments wells can be inspected at different frequencies. Wells that have more redundant safety features should lower the overall well risk and therefore can have longer re-assessment intervals. Some redundant safety features are listed below:
 - a) Annular pressure monitoring via SCADA;
 - b) Production casing cement to surface;
 - c) Casing, packer, tubing design;
 - d) Established corrosion rate estimate;
 - e) Surface or sub-surface emergency shut-off valves;
 - f) Well's isolation from populated areas; and
 - g) Other factors that may be identified
 2. As general guidance casing inspection re-assessment frequencies are determined based on the operator's risk assessment procedure and the information derived from baseline evaluations.
 - a) For re-assessments greater than 15 years substantial safety features and remaining life on the casing should be calculated using the established well corrosion rate from previous inspections.
 - iv. Volume, rate, pressure monitoring
 1. Each well should have a method of estimating or measuring the injection pressure and withdrawal/production rates from the well.
 2. Monitoring of each well's injection and withdrawal/production rates and pressures may be done by methods which do not disturb normal operations.
 3. Measurement sensors are calibrated with accuracy, resolution and repeatability metrics that are appropriate for the expected measurement ranges within well and environmental conditions and during extended testing and/or operating periods.
 4. The operator may also consider continuous monitoring of injection/withdrawal pressures.
 - v. Subsurface leak detection
 1. Subsurface leak detection may include various singular or combined methods based upon the operator's risk analysis and operational plan.
 2. Changes in a well's surface and/or downhole measurements may indicate a wide range of conditions, and measured changes may or may not be attributable to subsurface gas migration.
 3. The operator should use a variety of measurements from each well suspected of a downhole leak, and combine information from adjacent and similar wells within the field area and zones of interest to decide which further investigative methods will be applicable to diagnose whether and where a downhole leak is occurring. As needed integrity assessment tools as described in Table 6-1 can be deployed to identify the wellbore leak.
-

vi. Subsidence and cavern storage

1. Surface subsidence occurs when the surface of a well or group of wells, or established monuments, subside below a baseline surveyed elevation. Subsurface caving or formation collapse may or may not manifest itself by surface subsidence or by sink-hole formation.
2. Wellbore and reservoir integrity may be affected by subsidence.
3. Operators should monitor wellheads, well locations, and established monuments for any indication of subsidence, and if subsidence is indicated, measure the rate at which subsidence is occurring over field operating cycles and external conditions, and compare any measurements against the risk analysis and operational plan which should include established standards.
4. Various analytical methods developed to analyze subsidence data may be utilized to evaluate subsidence. These methods can include graphs of elevations versus time and field subsidence rate maps.
5. Consideration should be given for all cavern storage facilities to establish surface survey loops and conduct a monument grid survey on an annual basis to detect ground surface movement. All wells should be included in the monument grid network. The frequency of the subsidence surveys should be based on the operator's experience and as required by regulations.

vii. Inventory tracking

1. Operators can calculate base/pad gas storage volumes and monitor injections and withdrawals/production continually. That information can be evaluated using periodic inventory reconciliations, and analyses can be compared to measured data.
2. Cavern operators should monitor injections continuously with periodic inventory reconciliations, such as resetting the inventory in the cavern based on emptying or by wireline measurement referencing the most recent sonar survey.
3. For depleted reservoirs semi-annual shut-in tests should be performed to verify storage inventories as recommended in API RP 1171.
4. Operators can further analyze apparent anomalies when mass balance and other calculations vary from expected data.

c. Periodic Wellhead Inspections

- i. Refer to Section 12.b.vi-vii for information on wellhead inspections.

d. Periodic Wellsite Inspections

- i. Operators should create periodic wellsite inspection procedures following API RP 1171 Section 10.5 (10) to verify the functional mechanical integrity of natural gas storage wellsites.
 1. Such procedures may include:
 - (a) Reason for the inspection;
 - (b) Identification of operation personnel and training requirements;
 - (c) Directions to conduct the inspection;
 - (d) Frequency of the inspection;

- (e) Reassessment of hazards and potential threats; and,
- (f) Documentation, reporting, and recordkeeping requirements.

The operator may choose to combine wellhead and wellsite inspections into a single procedure.

e. Maintenance Requirements and Schedules

- i. Operators should include a maintenance schedule in the field operational plan.
- ii. Maintenance requirements are based upon the operator's risk analysis for the field, each field area, and each well based upon the risk factors, well and wellhead design, and historical experience operating the facility, wells, and equipment.
- iii. Maintenance schedules are based upon the frequency with which wells and wellhead components require work, and all maintenance should be regularly recorded and tracked for risk analysis reviews.
- iv. Records are typically maintained for the life of the facility.

f. Water Wells

- i. Gas storage fields may also have water wells drilled and completed for various purposes, including water source and monitoring.
- ii. Operators may include water well operation and maintenance in their field operating plan with the same or similar considerations as included herein for gas storage wells.
- iii. For aquifer storage facilities all water wells that see some gas pressure throughout the year should be designed according to Chapter 5 guidelines.

g. Well Reporting and Compliance

- i. Reporting requirements
 - 1. Operators can centrally record all measurements and analyses performed across field operations, including injections, withdrawals/production rates and volumes, pressures, maintenance, conditions, and other.
 - 2. Operators may periodically analyze the reported data for trends, issues, risk analyses, and reporting to outside agencies and organizations as appropriate.
- ii. Compliance schedule
 - 1. Operators should be familiar with all regulatory requirements, agencies, and other outside organizations' required information and dates for proper reporting compliance.
 - 2. Operators should have a written procedure for proper and timely reporting to government and outside organizations.

- iii. Agency notification and approval of changes to wells/operations
 - 1. Operators should have a written procedure for proper and timely reporting to regulatory agencies of any required notices and requests for approval when required for changes to wells/operations.
 - 2. Operators are advised to keep a written record of all notifications and approval requests and responses from agencies.

h. Procedures, Training, and Record Retention

- i. Operators should create a storage operation and maintenance procedure manual and an operator qualification program for UGS injection and withdrawal well activities. For cavern storage operators refer to API RP 1170 Section 9.7 for details. For porosity storage operators refer to API RP 1171 Section 11.

Chapter 9

Monitoring and Observation Wells

Introduction

Monitoring and observation wells associated with the underground storage of gas have been utilized by the gas storage industry for a many years. One purpose for the construction of these wells is to monitor for the potential horizontal and vertical migration of storage gas. These wells can be the first evidence of potential issues with gas storage reservoir integrity. The placement of these wells is of high importance to ensure adequate monitoring of the gas storage reservoir is accomplished. The use of and type of observation wells vary greatly with each storage project, and some storage projects may not require them.

Major Issues and Concerns

Addressing physical surface location placement, proposed depths, and geological considerations are major issues and concerns regarding monitoring and observation wells associated with gas storage facilities. A geologic formation selected for monitoring must have sufficient porosity and permeability to ensure monitoring is feasible. Locations and spacing of monitoring wells should be based on the geology and hydrogeology, including but not limited to flow paths, flow directions, and formation pressure gradients. Depth considerations of these wells can be critical and placement of some monitoring wells needs to be within the first porous and permeable zone directly above the gas storage reservoir. Monitoring or observation wells being considered for placement directly into the geologic formation(s) utilized for gas storage can be limited to the buffer zone (which is established outside of the delineated gas storage field) to potentially detect additional pathways of gas migration out of the gas storage reservoir within the storage field. The use of and need for observation wells may be determined as part of the risk assessment for each new gas storage project.

Main Take-Aways

- Observation and monitoring wells serve as the early detection and warning system for gas storage reservoir integrity; and for LPG storage, they can also serve to monitor the integrity of the brine system, including brine storage ponds.
- Placement of these wells both on the surface and in the correct subsurface geologic zone is critical to the success of an observation/monitoring well program.
- Proper well construction, integrity, and monitoring are important aspects of these wells.

Monitoring and Observation Wells

a. Reasons and Justification

- i. Monitoring and observation wells serve as an early detection and monitoring system for identifying potential gas migration and reservoir integrity issues. These wells can be utilized to establish baseline conditions and allow for monitoring of gas, and liquid conditions and changes. Groundwater monitoring wells can also be used to detect changes in groundwater quality that could be indicative of contamination.

- ii. Strategically placed observation or monitoring wells in the vicinity of reservoir spill points, within an aquifer, and above the confining zones in porous and permeable formations should be installed and monitored to detect the presence or movement of gas or LPG. Observation wells can be placed above, below, or laterally within the gas storage reservoir depending upon the geology of each gas storage project. (10) These wells need to be placed within porous and permeable geologic formations capable of being monitored. The location and design of observation and monitoring wells should take into consideration (16) the following:
 - 1. Location relative to the storage zone. Monitoring wells located within the storage zone that are suitable for monitoring reservoir pressure, can be considered but should be placed within the buffer zones in order to limit artificial penetrations within the gas storage field reservoir;
 - 2. Potential migratory paths from the reservoir to another formation;
 - 3. Fluid interface monitoring at the location of the reservoir spill point;
 - 4. Permeable zones and stratigraphic traps above the storage zones; and
 - 5. Low-permeability zones, formations or fields adjacent to and in communication with the storage zones.
- iii. Gas analysis from observation wells may provide proof of the arrival of storage gas when the hydrocarbon, inert gases, and/or isotopic composition of the storage gas is noticeably different than that of the native gas.
- iv. Monitoring wells completed in aquifers to determine groundwater quality should also be considered where appropriate. Groundwater monitoring at LPG storage operations should include placement and monitoring around the brine storage impoundments. These wells should be sampled initially for baseline fluid chemistry and then sampled periodically using a set of chemical parameters (including chloride), to determine if changes in groundwater quality have occurred.

b. Well Construction

Perhaps the most critical aspect of any well drilled within a gas storage field is an appropriate well construction plan. Observation and monitoring wells should consider:

- i. A well construction plan designed to ensure proper placement of well casing, cementing, and completion practices. It should provide for adequate safety, monitoring and sampling. It should also provide for the zonal protection and isolation of other reservoirs and aquifers intersected by each monitor and observation wellbore per regulatory requirements;
- ii. Appropriate testing protocols that can demonstrate the well integrity;
- iii. In salt cavern construction, use of salt saturated cement through salt zones when cementing a casing string set into the salt. A mule shoe and weep hole should be located a minimum of one foot above the bottom of the brine tubing to assist in the early detection of overfilling the cavern with product; and

- iv. Well construction of shallow monitoring wells in gas storage fields utilized for groundwater monitoring and baseline sampling needs to be as stringent as the deeper, observation wells. Construction, must meet minimum jurisdictional requirements and approvals.

c. Monitoring Type and Frequency

After initial observation or monitoring well completion and baseline recording and/or sampling have been accomplished, development of a monitoring, recording, and sampling plan needs to be undertaken. This plan should consider:

- i. Analysis for hydrocarbon, nonhydrocarbon gases, and/or isotopes.
- ii. Monitoring of pressure changes and fluid-levels. Sampling should be considered on a case-by-case basis by the regulatory agency as necessary.
- iii. Criteria for measurement sensors. Sensors may be located at the surface and/or downhole, with calibrated accuracy, resolution, and repeatability per manufacturer's specifications that is sufficient for the expected measurement ranges within well and environmental conditions during extended operating periods;
- iv. Monitoring and sampling frequency. The frequency of monitoring should take into account seasonal variations, and may change over time as the storage field transitions from activation to the mature stage.

d. Reporting Requirements and Alarms

Significant changes in pressure or the migration of gas into the monitoring or observation well borehole indicating a potential loss of gas storage well or reservoir integrity should require an immediate notification to the appropriate company representatives and to the appropriate regulatory agency or agencies. Additional observation or monitoring well reporting requirements for the presence of gas, pressure and fluid-level monitoring, and groundwater sampling should be developed cooperatively between the regulatory agency or agencies and the gas storage operator prior to installation. Additionally, real-time electronic monitoring on observation or monitoring wells at the surface should be considered and should utilize alarms set for significant changes in pressure or presence of gas at the lower explosive limit (LEL) beyond the original baseline readings.

e. Observation Well Operations and Maintenance

- i. Operations should refer to the relevant recommendations from Chapter 8: Injection and Withdrawal Well Operations and Maintenance, to ensure functional mechanical integrity of observation wells located in gas storage zones. Relevant areas are:
 - 1. 8.a.ii.1: Minimum and maximum operating pressure;
 - 2. 8.a.4: Workovers;
 - 3. 8.b.i: Annular monitoring;
 - 4. 8.b.ii: Casing inspection;
 - 5. 8.b.iii: Inspection and integrity frequencies;
 - 6. 8.b.v: Subsurface leak detection;
 - 7. 8.b.vi: Subsidence and cavern storage;
 - 8. 8.c: Periodic wellhead inspections;

- 9. 8.d: Periodic wellsite inspections;
- 10. 8.e: Maintenance requirements and schedules;
- 11. 8.g: Well Reporting and Compliance; and,
- 12. 8.h: Procedures, Training, and Records Retention.

Chapter 10

Wellhead and Surface Facilities

Introduction

The surface equipment at gas storage wells is the interface between the wells themselves and the compressor and pipeline systems used to transport the gas offsite. The handoff point between gas storage agency jurisdiction and pipeline agency jurisdiction may vary from state to state and even within facilities. Operators should work with oil and gas agencies to clearly delineate this point at each facility, and agencies may consider establishing MOUs with sister agencies to manage regulatory overlap and gaps. This report's scope focuses on the wellhead itself, the various valves and monitors found on the wellhead, the physical interface between jurisdictions (often a pipeline isolation valve), and surface leak detection related to the wellhead.

Major Issues and Concerns

Properly designed and functioning wellheads efficiently direct gas flow while providing operators with information about subsurface well integrity and preventing unintentional gas leaks at the surface. Designs consider issues like appropriate pressure ratings, valving, ability to perform workover and maintenance operations under pressure, pressure monitoring devices, emergency safety systems, and leak detection. Considerations include which systems to require, what kind of maintenance is appropriate, and what information should be reported to the regulator.

Main Take-Aways

- Wellhead configurations depend on a variety of factors, but there are manufacturing and testing standards for each component.
- The use of safety devices depends on well architecture, risks intrinsic to each well's history and location, and regulator risk tolerance with respect to safety and environmental considerations.
- Special attention should be paid to the point of regulatory handoff between the agency regulating the well and the agency regulating the pipeline network to ensure seamless regulatory coverage and cooperation
- Pressure monitoring is a common method for determining overall well integrity; regulators should consider appropriate measurement frequency and reporting requirements based on well history and other risk factors.
- Surface leak detection technology is rapidly evolving, and can play a role in a comprehensive leak detection program.

Surface Facilities

a. Overview

This section provides detailed guidance to help regulators develop rules and analyze operator plans related to wellheads, surface equipment between the wellhead and the point of hand-off to CFR 49 Part 192's pipeline regulations, pressure management and monitoring, and surface leak detection. The subsections below go into extensive detail on these topics, with cross-references elsewhere in the document as appropriate. (69)

b. Wellhead

i. General principles

1. The design criteria for wellheads at gas storage facilities should include, but is not necessarily limited to:
 - a) MAOP and maximum flow rate;
 - b) Number and size of casing and tubing strings;
 - c) Number and type of valves on the tree assembly;
 - d) Injection/withdrawal fluids composition;
 - e) Potential for solids production;
 - f) Pressure and/or temperature monitoring of annular spaces; and
 - g) Full bore access for well workovers.

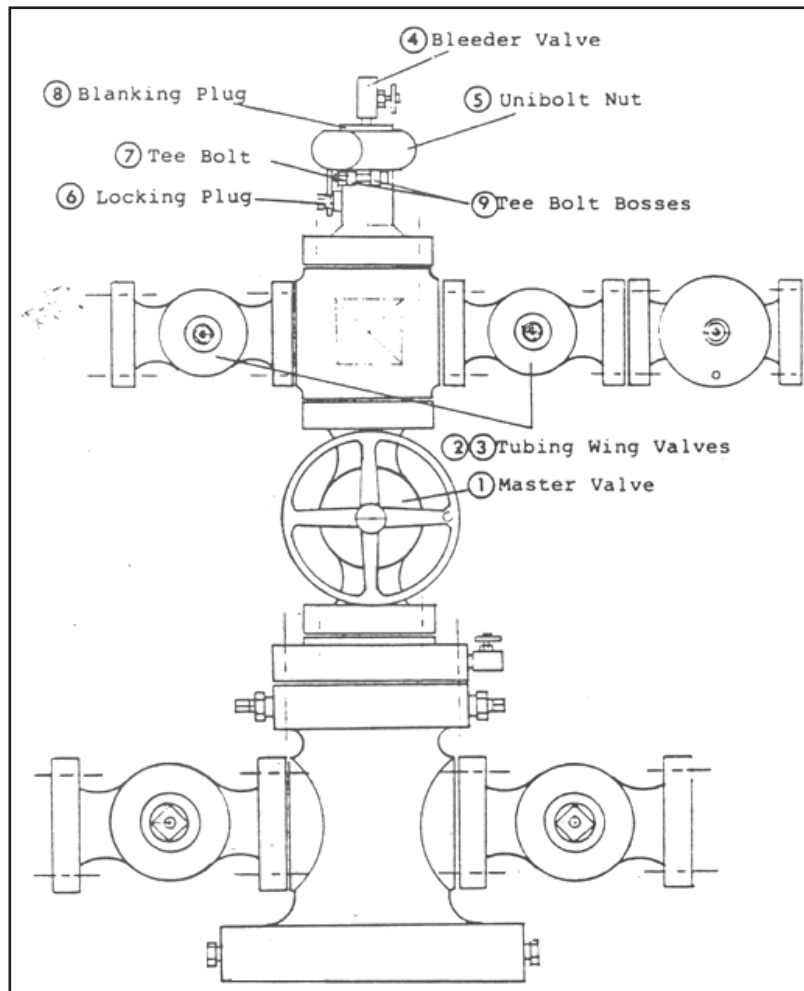

Figure 10-1: Example of a Depleted Reservoir or Aquifer Gas Storage Tubing and Casing Wellhead Configuration

Source: SoCalGas

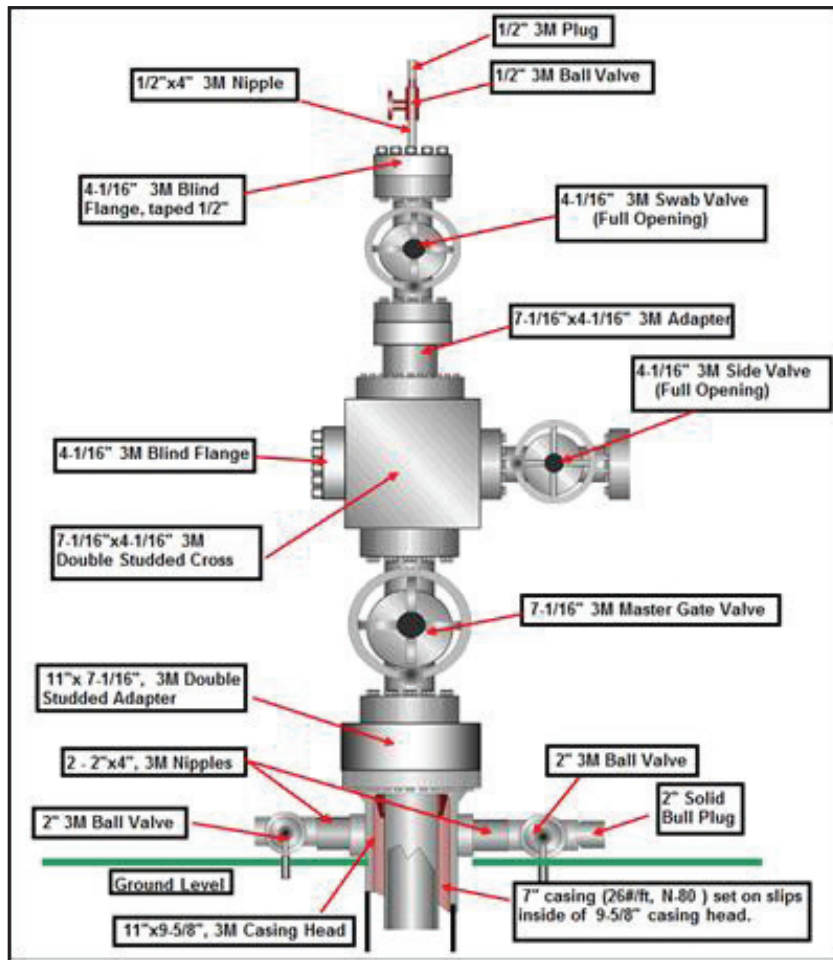

Figure 10-2: Example of a Depleted Reservoir or Aquifer Gas Storage Casing Injection/Withdrawal Wellhead Configuration
 Source: Anonymous

2. Wellhead equipment, fittings, valves, and flanges should conform to API Specification 6A, (18) and should be rated to a MAOP which exceeds that of the storage field. The potential for future expansion of the facility to a higher MAOP may also be considered, if feasible, so that the wellhead remains fit for purpose in the event of an expansion. Various types of valves may be used as part of the tree assembly, though typically gate valves or ball valves are the valve of choice because of their superior sealing capability and resistance to seal failure. The chemical composition of the injection and withdrawal fluid streams should also be considered. Trace amounts of CO₂ or H₂S in the withdrawal stream may result in detrimental effects to the wellhead internals and seals if the proper service trim level is not specified. Likewise, the potential for solids production and erosion should be evaluated and factored into the wellhead selection and design/specification. Full bore opening valves should also be considered in the design to enable passage of workover equipment and tools.
3. Other design criteria must also be considered. For example, the potential for hydraulic fracturing of the well, the use of surface and/or subsurface safety valves, whether downhole chemical injection may be necessary, and for cavern wells, the use of different wellheads for solution mining versus gas storage. Representative wellhead configurations for porosity storage reservoirs are shown in Figures 10-1 and 10-2. Figure 10-1 illustrates an example wellhead configuration

of a depleted reservoir or aquifer gas storage well where injection and withdrawal would be possible through both the production tubing and production casing. Figure 10-2 illustrates a wellhead configuration where injection and withdrawal would be done through the production casing.

4. API Guidance Document HF1, which provides guidelines for well construction and integrity, may be referred to if the gas storage well may undergo hydraulic fracturing during its life cycle (regulators may also be interested in API RP 100-1, which is an update of HF1). (69) If subsurface safety valves are determined to be necessary, the wellhead selection must accommodate passage of the safety valve and provide porting for safety valve control lines, or other small diameter lines for chemical injection.
5. For cavern wells, the hanging string may undergo potentially damaging oscillation during periods of de-brining/re-watering the cavern. Accelerometers should be installed on the wellhead to detect and respond to this condition. Also, a wellhead designed specifically for solution mining which allows for the injection of raw water, return of brine, and the injection of a blanket material to protect the cavern roof are required for proper control of the cavern design. The design of the wellhead should be based on site-specific conditions, which includes consideration of corrosion resistant internal coatings. Once solution mining is completed and prior to the commissioning Mechanical Integrity Test (MIT) and de-brining, a wellhead designed specifically for gas storage purposes must be installed. Wellhead components exposed to raw water and brine during solution mining should not be reused for gas storage service. API RP 1170, Sections 6 and 9 provide specific guidance related to the design of wellheads for cavern storage facilities. Figure 10-3 illustrates a typical wellhead configuration of a salt cavern well during the

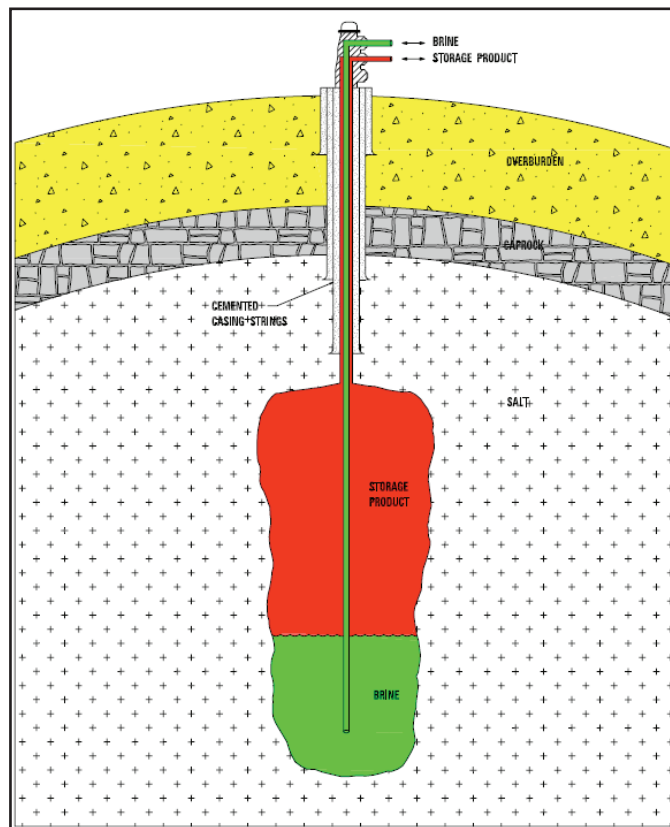

Figure 10-3 Example Salt Cavern Well Wellhead Configuration During Solution Mining
 Source: <http://caplaconference.com/wp-content/uploads/2015/04/Pipelines.pdf>



Figure 10-4: Example Salt Cavern Well Wellhead Configuration During Gas Storage Operations

Source: <http://caplaconference.com/wp-content/uploads/2015/04/Pipelines.pdf>

solution mining phase when fresh water is being pumped into and brine is being circulated out of the cavern during its development. Figure 10-4 illustrates a typical salt cavern wellhead configuration once development is completed and the cavern is being used for gas storage purposes.

6. Finally, if the wellhead is located in close proximity to roads, railways, airports, active farming operations, flood plains, or areas where landslides may occur, consideration should be given to the use of “Jersey” barriers, bollards, fencing, or other barrier methods that afford physical protection and limit unauthorized access to the wellhead.
7. Wellheads should be routinely monitored for operability, leaks, and mechanical faults, and annually inspected and tested to ensure functionality. Monitoring should include wellhead injection pressure and flow rate for unexpected, rapid changes in pressure or flow which may be indicative of a mechanical problem or abnormal operating condition. Annuli pressures should also be monitored for changes which may indicate an abnormal operating condition.
8. Emergency shutdown valves which are integral or adjacent to the wellhead tree assembly may be appropriate based on an analysis of site-specific risks. These types of valves may be activated by conditions such as over-pressuring, excess flow, gas leakage, and/or heat detection.

ii. Master valve

1. UGS wellheads should consist of at least one master valve. This applies to casing only or casing-tubing-packer completions. Master valves give operators additional well control and isolation options and allow them to perform certain maintenance activities under pressure such as snubbing or wireline operations.
 - a) Valves should be inspected and function tested for operability and sealing capability at least once per year, (or as required by regulations) and inspection and test results documented. More frequent inspections may be appropriate based on site-specific risk factors or conditions which include produced fluids which are corrosive, solids production, prior to and immediately after workovers, and following hydraulic fracturing or other well stimulation activities.
 - b) Valves should be lubricated and serviced as indicated by the manufacturer and in accordance with the operator's routine maintenance programs.

iii. Isolation valves

1. Valves which isolate the wellhead from the gathering system or pipeline should be inspected and function tested for operability and sealing capability at least once per year, and inspection and test results documented. More frequent inspection may be appropriate based on regulations and on site-specific risk factors or conditions similar to those mentioned above for master valves. This is particularly true for wellhead wing valves which serve as isolation valves between the wellhead and gathering system/pipeline.

iv. Other valves (snubbing unit, wing, etc.)

1. Other valves may also be incorporated into the wellhead including swab valves (snubbing unit) which may be located above the master valve or at the very top of the wellhead tree, and wing valves on the side of the tree, as previously mentioned. Swab valves are used for isolation during other well work activity such as wireline work or coiled tubing work, and wing valves (also known as side gate valves) may provide another means of injecting into the well during kill operations. Inspection, testing, and maintenance activity on the other valves listed here should be performed at least once a year and inspection and test results documented.

v. Emergency shut-down devices

1. Surface Safety Valves: A surface safety valve can be installed on a wellhead (typically a type of master valve) or located as a wing valve and small diameter low pressure check valves on the annular spaces in certain instances to prevent oxygen access to the annular space. Surface safety valves are typically designed to automatically close (fail safe) based on conditions that may include excess flow or pressure, gas detection above LEL, erosion, or fire. Small diameter check valves are typically spring-loaded and normally closed; they open only in an "overpressure" condition. Circumstances where use of surface safety systems may be appropriate should be addressed as part of an overall site-specific evaluation of threats and potential consequences (risk analysis). All components of safety valve systems should be tested on a regular schedule, based on operating conditions and historical performance or as required by regulations
2. Subsurface safety valve: A subsurface safety valve is typically installed on or in a tubing string below the wellhead. The purpose of a subsurface safety valve is to allow an operator to shut-in the well below the surface in the case of a surface

emergency or if the wellhead is damaged. Subsurface safety valve are typically designed to automatically close (fail safe) based on conditions which may include loss of the wellhead, loss of functionality of the wellhead, and surface conditions such as fires that may endanger the wellhead from functioning as designed. Circumstances where the use of a subsurface safety valve may be appropriate should be addressed as part of the overall site-specific evaluation of threats and potential consequences (risk analysis) and performed on a per well basis.

3. API RP 1171 Section 6.2.5 provides guidance concerning emergency shut-down valves in general, and when and where such systems may be appropriate. This includes both surface and sub-surface safety valves. Considerations include but are not necessarily limited to:
 - a) Distance from dwellings, occupied structures, playgrounds, etc.;
 - b) Distance between adjacent wellheads or other production equipment;
 - c) Gas or fluid composition and maximum flow potential;
 - d) Proximity to roads, railways, airports or other rights of way;
 - e) Current and future development potential;
 - f) Alternative measures that could afford physical protection to the wellhead; and
 - g) Added risk created by installing and servicing safety valves.
 - h) Other considerations, which may include:
 - 1) proximity to environmentally or culturally sensitive areas;
 - 2) proximity to seismically active areas, faults, floodplains, or land slide potential; and
 - 3) risk of sabotage.

Where installed, these systems should be function tested at least annually and in accordance with API RP 14B. (70)

vi. Wellhead Seals such as gaskets, packing and welds

1. Seals, gaskets, and welds should be inspected as part of routine wellhead inspections. Gaskets, including, ring and conventional flat-faced, should be replaced and not reused any time the seals are broken during maintenance activity or when evidence of leakage is detected. Packing materials, such as injectable plastic, may be used for remedial purposes in sealing minor wellhead leaks on wellheads equipped with injection/test ports.

vii. Corrosion/Erosion inspection

1. Routine inspection of surface equipment and development of a corrosion management program are integral to effective wellhead integrity demonstration, verification, and monitoring.
 2. Corrosion coupons may be useful in concert with other monitoring methods, such as produced fluids sampling and analysis, for monitoring internal corrosion rates and/or the effectiveness of corrosion inhibitor treatment programs.
 3. Acoustic sensing devices (ultrasonic probes) may be useful in detecting both internal corrosion and erosion. A program of periodic surveys at pre-defined locations on valve bodies, elbows, and/or other fittings where flow impingement occurs can be effective in assessing internal integrity where other methods are not possible or practical.
 4. Corrosion probes, also known as electrical resistance probes, provide another option for monitoring internal corrosion rates. The action of corrosion on an exposed metal element reduces the cross-sectional area of the element, thereby increasing its electrical resistance. The value of the resistance increases in a predictable manner with the depth of corrosion, which permits an accurate determination of the corrosion rate.
-

5. Sand probes work on a similar concept as corrosion probes. Sand and abrasives erode a sacrificial sensing element that is inserted through a sealed high pressure assembly. Abrasives eventually erode through the probe, exposing the sealed assembly to working pressure, which is detectable via pressure gauge or alarm.
 6. Other inspection methods and procedures may be employed if microbially-influenced corrosion is suspected or likely. This would likely include obtaining fluid samples and culturing the samples for the presence of viable bacteria, such as sulfate reducing bacteria. If active cultures are detected, treatments with the appropriate biocides should be considered.
- viii. Cathodic protection (CP)
1. Considerations and justification of whether wellhead and well casing should be protected is a site-specific issue. Buried gathering lines and pipelines at storage facilities typically have impressed current applied to them for corrosion protection. Some storage facilities apply CP to well casing strings and wellheads while others install insulating flange gaskets, washers and bushings to isolate the wellhead and casing strings from electrochemical corrosion. Factors such as the corrosivity of soil and strata above the gas storage zone, the presence or absence of fully cemented casing strings, and the risk of damaging stray current should be evaluated when considering whether or not to apply CP to the storage wells.
- ix. Atmospheric coatings
1. All wellheads and exposed connected piping shall be coated to prevent atmospheric corrosion.

c. Pipeline Isolation Valve / Equipment Between Wellhead and Hand-off to USDOT Jurisdiction

The pipeline isolation valve is the location at each storage facility where regulatory oversight transitions from the regulatory agency that has responsibility for gas storage wells, to the regulatory agency that has responsibility for pipelines. The location of this valve might be different for each storage facility depending on whether the facility is an intrastate or an interstate facility; it may also vary from state to state.

In many states the hand-off point between well and pipeline regulatory responsibility occurs at the point of interconnect between the downstream flange of the wing valve on the wellhead to the flange of the gathering line/pipeline which connects it to the wing valve. However, this convention is not universally applied. In some instances, the hand-off point may be further downstream (closer to the storage field compressor station or transmission line), and there may be additional equipment between the wellhead and the hand-off point between regulatory agencies. This equipment may include, but is not limited to, wellhead measurement facilities, separators, sand/solids traps, chemical injection facilities, or other production related equipment such as pig launchers/receivers.

Regulators from these two different agencies (wells and pipelines) should consult with each other and with the storage operator and agree on the specific location where the transition occurs, and operational considerations related to the hand-off point. This will ensure clarity for all affected parties, minimize uncertainty concerning regulatory compliance requirements, and best serve the interests of public safety. It may also help avoid potentially conflicting or confusing directives.

d. Pressure Management/Monitoring**i. Equipment**

1. Equipment associated with pressure management and monitoring at gas storage facilities includes, but may not be limited to:
 - a) Pressure control valves;
 - b) Pressure relief valves and emergency shut-down systems (ESD);
 - c) Calibrated dead-weight pressure gauges;
 - d) Calibrated digital and analog pressure gauges;
 - e) Temperature-compensated pressure transducers; and,
 - f) check valves.
 2. Pressure control valves are typically used to reduce storage field gathering system pressure down to the pipeline transmission system pressure. These types of valves are oftentimes located between a storage well and a pipeline isolation valve, though some facilities exist where the pressure control valve is on the well head. They may at times be used to control station inlet pressure to a storage field compressor station. These types of valves are typically automated valves that are controlled via station automation systems, electronic data monitoring system, or SCADA systems. Pressure control valves may also be used at individual wells, though that is a less common application. Routine inspection and maintenance on these types of valves should be per manufacturer's specifications and in accordance with the operators routine operations and maintenance procedures.
 3. Pressure relief valves and ESD systems are designed to protect the storage facility by preventing exceedance of the facility MAOP including compressor station piping, brine lines and fresh water lines for caverns, and storage field gathering system piping, against a situation where MAOP is exceeded. Relief valves are typically installed on the discharge piping at a storage field compressor station and other locations within the storage field piping immediately downstream of where there is a reduction in the maximum allowable operating pressure (specification break) in the piping. They may also be installed on pressure vessels such as separators and other process equipment where an overpressure condition could occur. Relief valves are subject to federal USDOT testing/verification requirements under 49 CFR Part 192 for natural gas storage facilities and under Part 195 for liquid hydrocarbon storage facilities. The flow capacity of relief valves must be verified and documented annually by the operator to ensure they meet federal safety standards.
 4. All ESD systems should be tested annually, or more often, depending on operating conditions and performance history, to ensure they perform as intended in the event of an emergency. For cavern wells, ESD valves are typically located on or near the wellhead and are automatically activated in the event of excessive pressure or flow. They should allow for local and remote activation, electrically and mechanically. All components of the system should be tested including, valves, transmitters, switches, and other end devices. Results of all inspections, maintenance, repairs, and testing of this equipment should be documented by the operator. Inspectors for the regulatory agency with jurisdiction should be afforded the opportunity to witness testing of these and all other safety systems.
 5. Other types of pressure monitoring equipment commonly used at storage facilities include dead-weight pressure gauges, analog gauges, digital electronic gauges, and electronic temperature compensated pressure transducers. These instruments should all be subject to periodic calibration and function testing (at least annually) against a known calibrated standard gauge to ensure accuracy. Malfunctioning
-

equipment is repaired or replaced, and equipment that can't be calibrated within manufacturer's specifications is replaced.

6. Pressure check valves may also be used in some instances where fluid flow is acceptable in one direction, but not in the other. These may include flow lines which are used for storage withdrawals only, and on the annular spaces of wells to prevent oxygen from entering the annular space. Inspection and maintenance of these types of valves should be in accordance with manufacturer's specifications.

ii. Protocols

1. Storage operators monitor operating pressure of their storage facilities on a real-time basis for the purposes of evaluating facility performance and monitoring system integrity. This should include developing and implementing procedures for routine monitoring, recording, and analysis of the tubing and annulus pressure conditions at individual wells to aid in identifying abnormal operating conditions and potential wellbore integrity issues. Pressure readings may be obtained and recorded either manually or via automated readings from an electronic data monitoring system or a SCADA system. The frequency and type of monitoring that is required should be based on site-specific conditions and a risk assessment to identify potential threats and hazards to the storage operation. But in any case, pressures should be monitored at least daily, and operators should keep adequate logs of these results.
2. Operators should develop and implement procedures for investigation and remediation of abnormal tubing and/or annulus pressure conditions. This includes but is not necessarily limited to:
 - a) Safely validating anomalous pressure readings to confirm whether a loss of integrity has occurred;
 - b) Internal and external notifications to company officials, regulators, and local first responders, if a leak is confirmed;
 - c) Determining whether a leaking well can/should be isolated from the gathering system;
 - d) Conducting follow-up testing including gas sampling and analysis to determine the source of the leak;
 - e) Performing further evaluations by temperature/noise surveys, and other surface and downhole assessments to identify the source of the leak;
 - f) Performing remedial repairs if possible or plugging and abandonment of the well;
 - g) Documenting all steps taken to address the issue; and
 - h) Implementing contingency procedures where necessary.

iii. Automation

1. An electronic data monitoring system or SCADA system may be used to monitor and control storage facility process flow conditions in real time. These systems may be associated only with compressor station operations at some facilities, or may be more complex (due to the requirements for wired or wireless communications equipment) and include real time monitoring and control of each of the storage wells or storage caverns, as the case may be. They may be configured for monitoring only, for on-site control only, or remote (off-site) control, including routine start/stop capability of process equipment and flow; and they may include system alarms (audible and/or visual) and automatic shut-down in the event of process upsets or abnormal operating conditions.

2. At cavern facilities during solution mining operations, SCADA systems may be used to monitor and control the solution mining process. These systems generally incorporate instrument control and shut-down capability to safely isolate the cavern/well in the event of abnormal operating conditions and emergency situations. They alert operators to system upsets that may require further investigation and/or operator response. This includes, but is not necessarily limited to, rapid increases in brine outflow rates, oscillation of the hanging string during debrining, and complete or partial failure of the leaching or debrining string.
3. Electronic data monitoring systems may be used to monitor and control gas injections and withdrawals on a real time basis. This may include the capability to monitor and control system pressure, flow rate, and shut-in capability. It may also include the capability to control pressure and flow from individual wells at some facilities. ESD systems should be integrated into the overall electronic data monitoring system or SCADA system at any storage facility. Both audible and visual alarms should be incorporated into SCADA control to alert operators to process upsets and abnormal operating conditions. The electronic data monitoring system or SCADA system functionality and system safety components should be tested periodically to ensure all instruments are properly calibrated and functioning per design capability, all alarms function properly, and the system performs as intended in the event of an emergency. All components of the system should be tested and results recorded and documented according to regulatory requirements and/or operator procedures. Often a Control Room Management Plan is required per 49 CFR 192 and 195; this plan will give details on required procedures and SCADA design and management.

e. Surface Leak Detection

Surface leak detection appropriate for surface equipment at storage well sites leverages heavily on methods utilized at other oil and gas infrastructure, including production wells, compressor facilities and distribution networks. Active leak detection programs are often structured in Leak Detection and Repair, where leaks are detected utilizing a variety of techniques, scheduled for repair or monitoring, and then repaired. Surface leak detection has evolved rapidly in recent years. Currently deployed processes often utilize staff to perform leak detection and assessment. In addition, new technologies are in development, allowing for reliable and low-cost continuous leak detection over short distances. The different surface leak detection technologies can be used in concert, with some specializing in detection and others in location (to facilitate repair). When considering new technologies for regulatory requirements, or in approving an approach as part of a RMP, regulators should consider pilot projects to test the efficacy and cost effectiveness of different setups in different circumstances, and should endeavor to audit the results of leak detection systems to ensure functionality meets expectations.

- i. Typical leak survey processes in current use:
 1. States may consider requiring leak surveys at regular intervals with appropriate levels of reporting for tracking and control.
 2. Optical Gas Imaging - Leak surveys of well sites can be performed using an Optical Gas Imaging (OGI) camera, a type of IR camera which filters light to highlight methane in escaping gas. During a leak survey a trained camera operator walks through the site (e.g. a well pad), and observes every potential leak point, including unions, gauges, valves, separator equipment, etc. A leak is typically defined as an observed plume in the OGI camera viewing screen. (Example: 40 CFR 98.234 - Monitoring and QA/QC requirements) The operator then records and, optionally, tags the leak for future tracking. Large leaks are reported to repair teams immediately.

Approach	Example Technologies	Type	Frequency	Status	Pros	Cons	Brand Examples
Ground-based Optical Gas Imaging (OGI)	Forward Looking infrared camera; hyperspectral camera	Handheld	Daily to Weekly	IR camera widely used; hyperspectral cameras emerging	Able to visually identify leaks; Highly efficient survey time	High capital cost; high labor cost; detection only during surveys; detection limit dependent on operator skill and weather conditions	FLIR; OPGAL; Rebellion Photonics
Aerial surveys	Forward Looking infrared camera (low elevation); Infrared imaging spectrometer	Aerial	Periodic	Emerging	Able quickly survey large number of sites	Only can identify the largest leaks	Leak Surveys, Inc; Kairos Aerospace
Point measurements (Handheld)	Flame ionization detector; tunable diode laser	Handheld	Periodic	Method 21 widely used;	Measurements identify individual leaks	Handheld measurements only detect during surveys;	Los Gatos; Bascom
Point measurements (Stationary)	non-dispersive infrared sensor	Stationary	Continuous	Emerging; Pilot programs in California and other states	Provide continuous measurements	Requires data analysis for leak detection; Can be costly in wide spaced fields.	
Open Path Infrared	tunable diode laser	Stationary	Periodic/ Continuous	Emerging / In use in some states	Stationary monitors provide continuous measurements	Handheld measurements only detect during surveys; continuous monitors require data analysis for leak detection	Boreal; Heath RMLD

Table 10-1: Leak Detection Approaches

- a. The efficacy of OGI surveys is well respected, though the technology and practice continue to evolve. Several cautions should be noted. First, OGI effectiveness is highly dependent on wind conditions – smaller leaks are difficult to pinpoint during higher wind conditions. For example, one vendor provides detection limits ranging from 0.8-11 g/hr, based upon degree of mixing and wind speeds from 0-5 MPH. (Benson et al.). States should consider maximum wind limits for which an OGI survey is considered valid. Wind limits are available from some of the camera vendors. Second, the IR image in an OGI camera is the combination of both light absorption by methane and temperature gradient against the background or reflected light source. Leaks may be difficult to detect in low-contrast conditions,

- and teams should observe key locations on a site from different angles to maximize the opportunity to highlight the leak against the background.
- b. Some operators have already begun to implement OGI as part of regular facility inspections, with both in-house and third-party contracting firms performing this work. In addition, several local and state agencies are using OGI equipment within surveys and audits as part of normal inspection and enforcement efforts to determine the presence of leaking components. As more inspections and research are performed, the additional data on OGI use should be collected and analyzed. At the same time, operators should be exploring the use of OGI as an additional tool for surface facility integrity verification.
 - c. Increasing frequency of OGI inspections, in theory, will detect leaks sooner and provide multiple opportunities to identify any one leak. However, operator fatigue that builds with many repetitious surveys may reduce survey efficacy, and states should be cautious about unduly increasing the frequency of OGI surveys.
3. Remote leak detection – typically using laser absorption instruments (e.g. Heath RMLD™) – may be an effective complement to OGI. Laser instruments can quickly scan components, identifying leaks to a small area, which can then be inspected with OGI to localize to a specific leak source. As with OGI, laser detectors are sensitive to wind conditions and should only be utilized in below a maximum threshold wind speed.
 4. Leak detection with quantification - If emission rates measurements are desirable, most leaks at well pads may be measured using high-flow instruments, (e.g. Bacharach Hi Flow® sampler). Due attention should be paid to calibration of these devices, at least daily or after any contact with wet gas, in alignment with manufacturer’s specifications. (“Bacharach Hi-Flow Sampler, Instruction 0055-9017, Operation and Maintenance” 2015; Howard, Ferrara, and Townsend-Small; Howard; Allen, Sullivan, and Harrison). In addition to high flow samplers, some monitoring companies (e.g. Rebellion Photonics) have developed OGI based systems that are paired with sophisticated computation algorithms to quantify emissions rates and volumes from leaking components.
 5. Non OGI point-source leak detection – Methane leak detection has been occurring at sites across the country for decades, either using hand held equipment or stationary equipment. States may consider requiring point-source leak detection at some or all gas storage wells, depending on facility architecture, weather patterns, topography, and safety and environmental risk tolerances – such systems are being piloted at facilities in California and elsewhere. Mobile leak detection technology (leak detection affixed to mobile detection equipment), while also rapidly evolving, is generally more expensive to operate, but can help in initial surveys to determine baseline leak information, in finding leaks once detected by a point-source device, in quantifying leak flux rates when desirable, and in verifying the success of repairs and remediation programs. Equipment types available for this purpose include:
 - a. Stationary Point Source Gas Detectors – Various types of equipment are available for leak detection at storage fields, and the appropriate technology may vary depending on a variety of factors such as the source of a potential leak being monitored (surface emissions from subsurface leakage or well pad emissions), the proximity of wells to one another, and the overlying

topography of the field (water flooded, topographic fluctuations, etc.) These factors may greatly affect both the quality and consistency of detection and the cost effectiveness of this solution. Point detectors typically use Non-Dispersive Infrared (NDIR) sensors calibrated for Methane. Point Detectors need to be strategically deployed in sufficient numbers at proper locations to compensate for day-to-day changes in wind speed and direction. Analytical models such as Gaussian Plume analysis can be employed to aid in determining detector placement. Networks of point detectors can be made much more robust if combined with on line data analytics that overlays data from all detectors in the system and adds other data such as local wind speed, local wind direction, pressures at key points in the system, and position of control valves. The density of sensors required to adequately cover a gas storage field varies widely with facility architecture, weather patterns, and topography, and will change both the effectiveness and cost efficiency over time with the advent of newer sensor technologies.

- b. Other Types of stationary gas monitors may also be utilized for detecting and quantifying surface emissions from localized areas, or for establishing a perimeter monitoring system to evaluate a larger area. Whatever the area, stationary monitoring technologies exist that can detect methane concentrations at very low levels and automatically alert operators of the elevated presence of methane. These technologies include open path infrared gas detector technologies and extractive analyzers that also use NDIR detectors.
- c. Mobile monitors – several types of monitors and monitoring techniques exist for use in handheld, vehicular, airplane based, drone based and satellite based applications. These systems generally employ sophisticated infrared imaging technology. The selection of deployment method (e.g. airplane, hand-held, vehicular, or satellite based systems depends largely on the reason for the monitoring activity.) These systems have been demonstrated as effective at locating leaks. These technologies generally required a highly trained operator to correctly interpret the data gathered by the devices. These technologies are generally expensive in terms of initial cost of the devices, cost of operating the mobile equipment and cost of labor for trained operators. Generally, these technologies are cost prohibitive for routine daily monitoring but are important for periodic surveying of sites, locating the specific source of hard to find leaks identified by fixed systems, and confirmation of remediation of discovered leaks.
- d. Strengths and weaknesses of existing inventory methods: Traditional inventory methods for natural gas storage fields, like other oil and gas segments, have tended to undercount actual emissions as determined by more advanced techniques. Due to the presence of super emitters, and potentially inaccurate emissions factors, higher than expected component numbers, and equipment fatigue/ corrosion processes have led to higher emissions than expected. Due to advancements in aerial survey techniques and peer reviewed research developed in the field, inventories that utilize aerial surveys may increasingly be seen as a leading practice
- e. New technologies for continuous monitoring are becoming more widely available and are offered at reduced costs. These technologies allow advanced monitoring using stationary gas detectors, both in arrays of

point detectors, and area monitors (open path and extractive.) Applications are being developed and deployed at several oil and gas sites. Although some of these sites have used expensive infrared imaging systems that require continuous onsite personnel, new continuous monitors that use both infrared (NDIR) point detection and infrared laser-based detection (open path detection) do not require significant facility personnel to operate, and can communicate remotely with existing computer (Distributed Control System or Programmable Logic Controller) and/or facility SCADA systems. Such technology may be used to develop sensor networks at lower cost than infrared imaging systems. Available wireless technologies may significantly reduce the cost of installing point detectors. Traditionally point detectors required connection to line power and a direct signal wire connection to the host controlsystem and/or data analytic system. Wiring costs will exceed the equipment costs by factors of x 10 or greater. New developments in wireless self powered instrument technologies now allows point detectors to operate off grid on long life lithium batteries and transmit their data using self-organizing wireless mesh networks. Wireless systems can also be used for monitoring other parameters such as pressure, temperature, and valve positions using available self-powered, wireless mesh network instruments. Open source protocol based wireless mesh network are becoming increasingly common in the oil and gas industries. Pilot programs are recommended to validate the effectiveness of this technology under field conditions. Field conditions, such as weather or topography, may affect the reliability of results and cost effectiveness of continuous monitoring as a solution.

- f. On line data analytical software is available and used by many large oil and gas companies, and can be provided by third-party contracting firms. This type of software overlays data from point detectors, open path area monitors, and other data such as local wind speed and direction, pressures and temperatures at key points in the system, and valve positions. On line continuous analysis of the data using algorithms in the software allow differentiation from normal releases such as bleeding of pneumatically actuated valves, normal operation of pressure relief valves, or depressurization of systems for maintenance from unintended leakage from the systems. The data analysis helps to quickly identify the source and approximant magnitude of a leak and allows maintenance to be quickly deployed to assess and repair.

- ii. Frequencies

- 1. Daily audio-visual observations are required at some storage sites, with operators visiting well platforms to observe equipment for odors, noises, and visual cues of leaks.
 - 2. Continuous monitoring equipment is increasingly accurate and sensitive while costs are falling, and may be considered at natural gas storage field well sites, within a relatively short distance from well sites (approx. 100 feet), (71) (72) (73) and along facility fence lines. Several states currently require continuous leak detection at certain gas storage wells that pose immediate safety risks, while others are considering continuous leak detection at all gas storage wells. Resources include the Department of Energy's ARPA-E MONITOR technology program.
-

(<https://arpa-e.energy.gov/?q=arpa-e-programs/monitor>) and the Environmental Defense Fund's Methane Detectors Challenge (<https://www.edf.org/energy/natural-gas-policy/methane-detectors-challenge>).

3. For mobile leak detection:
 - a. In the absence of continuous leak detection, approximately weekly surveys using OGI or OGI plus laser detector may be appropriate.
 - b. Leaks should be identified (tagged and recorded) and persistent leak locations tracked over time. States should consider requiring measurement of persistent leaks, and requiring repair for leaks above a set threshold within a specified time period.
4. States should design regulations so that companies may shift from existing processes (e.g. OGI surveys) to automated systems as technology advances and costs drop.

iii. Thresholds

1. Technology exists today that allows for rapid detection of elevated levels in parts per billion of methane above background. States should consider the upfront and maintenance costs and lifespan of such systems versus parts per million systems. States may develop standards on appropriate threshold requirements to investigate elevated methane readings based on proximity to populated areas, the potential for a large-scale release, and general risk tolerance.

- iv. Overview of measurement methods. Notes on quality control by adhering to appropriate measurement protocols.
- v. Considerations for cavern leak detection include both heat and gas detectors.

Chapter 11

Emergency Response Planning

Introduction

Emergencies create safety and environmental risk and disrupt routine business activities. It is therefore important for operators to develop an effective Emergency Response Plan (ERP) that will enhance protection, mitigation, and response to the full range of possible emergencies. Thorough preparation and practice will result in reduced impacts to life, property, and the environment and promote a swifter return to routine business. ERPs are unique to each site and project. ERP is a dynamic and ongoing process. All ERPs must be reviewed, modified, and updated frequently to ensure appropriate responses to foreseeable emergencies. The consequences of outdated or inadequate ERPs can include greater damage to life, property, and environment, as well as fines and criminal or civil suits.

The purpose of this chapter is to introduce regulators to key elements of an ERP. There is no single template for an ERP, but they should have at a minimum the topics in this chapter. This chapter is not intended to be exhaustive in coverage. Regulatory bodies and organizations must also consult a number of applicable international, federal, state, and local standards for guidance in evaluating and developing comprehensive operation-specific ERPs such as ISO 22301 (71), CSA Z731-03 (72) and NFPA 1600 (73).

Major Issues and Concerns

Critical components of successful emergency response should be addressed during ERP, including:

- Total commitment of leadership and staff with a clear purpose and scope;
- Identification of needed resources, response team organization, roles and responsibilities, and comprehensive internal and external communication systems;
- ERP planning that includes goals, objectives, an incident management system, risk assessments and comprehensive hazard identification;
- Coordination of response actions with government or other emergency response entities;
- Development and implementation of a plan that has clear procedures, recordkeeping, incident management protocols, and incident termination/recovery steps; and
- A comprehensive training and education program, aimed at training and educating personnel to consistently display competency in executing the ERP. All exercises and drills should test the ERP effectiveness with lessons learned and corrective actions implemented. They should integrate all interested parties/agencies and incorporate input from all participants.

Regulators may also recommend that operators:

- Coordinate continuous development and modification of ERPs with appropriate authorities (e.g., fire department with facility jurisdiction, and others);
- Perform a thorough hazard identification and associated risk assessment of all phases of their operation; and
- Employ an objective, independent and competent audit function to continually assess the ERP.

Main Take-Aways

- ERPs are used to protect life, property, and the environment. Their design also helps prevent or mitigate impacts suffered in emergency situations. ERP strategies also include developing plans to address a comprehensive range of emergency situations.
- ERP and preparation is a dynamic and ongoing process.
- ERP design and update involves multiple stakeholders including first responders, regulators, internal staff and leadership, and media and community representatives
- Important parts of ERP design are hazard identification and the assessment of associated risk with effective responses managed through an incident management system.

Emergency Response Program Organization

Protecting life, environment, and property must be a core value that is intimately threaded throughout an organization. A properly organized ERP communicates deep commitment to the organization and affected outside agencies and communities. Organizations must address leadership, team structure, roles and responsibilities, resource allocation and deployment, and communication.

a. Purpose and Scope

An effective ERP will guide personnel in emergency preparedness, response, and management. In so doing, the safety of personnel, public, environment, and property will be protected to the maximum extent possible. Recovery times will be reduced for both surrounding communities and routine business activities. A properly designed and executed ERP (covering unique facility attributes as well) will establish minimum guidelines for emergency preparedness, response, and management. It applies to all levels of staff and management, outside emergency response and regulatory agencies, and adjacent communities that may be affected. The ERP will be applicable to all phases of operations including entities owned or contracted by the organization.

b. Leadership, Commitment and Policy

The ERP and its support program must have full commitment of leadership, especially at the executive level. Support must be clearly evident to the entire organization or the ERP and support program will be marginalized. Developing policy pertinent to the ERP is vital and should be a joint effort of management and staff reflecting the organization's core values. ERP policies should be easy to understand and apply, and must include clear statements of everyone's commitment to protecting life, environment, and property. Knowledge, understanding, and implementation of this policy are everyone's responsibility.

c. Response Team Organization

Many organizations use the Incident Command System (ICS), National Incident Management System (NIMS), or close variations which are well known with documented success. These systems are flexible and will cover the full range of emergency situations. They provide an organized set of scalable and standardized operational templates for structure. It is vital to train the organization to use the ICS or NIMS templates if selected for ERP implementation as most businesses organize their operations differently. Important team components are audit and regulatory. The audit function must be objective and independent. Audits must be conducted regularly and with a frequency to insure the ERP is performing as designed and desired. Audits should include detailed records, analysis, summary of plan performance, and corrective

actions at a minimum. A well trained regulatory staff is vital to keep an organization informed and coordinate with all outside regulatory agencies. The ERP must always adhere to all applicable laws, rules, and regulations.

d. Roles and Responsibilities

Well-defined roles and responsibilities, and training to understand them, are critical. Many organizations adopt systems such as RACI (Responsible, Accountable, Consulted, and Informed) to agree upon and communicate all roles and responsibilities for the entire ERP. Roles and responsibilities must be understood to insure the most effective and efficient ERP.

e. Resource Allocation and Development

Defining critical resources is required for an effective ERP to respond properly to an emergency. Resource needs extend beyond money, equipment, and manpower. The organization must devote time, energy, and expertise to identify resources that will be needed to build and manage a comprehensive logistics network, and acquire, manage, and deploy all the necessary resources for an effective ERP. The distribution and logistics function must incorporate a tracking system to insure all staff is supplied with the necessary resources, training, and up-to-date information. Documenting and tracking extraordinary costs associated with the ERP and emergencies are needed as well as any alternative authorization levels in management to avoid confusion or duplication during emergency situations.

f. Communication Systems

The ERP should thoroughly address all aspects of communication. Routine communication networks should include, but are not limited to, procedures, equipment and personnel deployment (primary and back-up), and alarms supporting specific operations. Emergency response operations will likely require communication plans that are specific to the emergency event and location.

A communication plan should include:

- i. Public information avenues;
- ii. Professional communications personnel;
- iii. Links to all outside agencies and regulators; and
- iv. Methods to address appropriate internal audiences.

During emergencies it is important to coordinate the dissemination of accurate, timely, and appropriate information. Communication sources and receptors must be well defined to avoid confusion. There must be information sharing between facilities, emergency responders, and affected communities. Proper communication systems and procedures save lives and better protect property and the environment in emergencies.

Emergency Response Planning

The ERP is the culmination of established standards, regulations, experience, and coordinated dialogue with all stakeholders. It addresses specific needs and applications as well as goals and objectives. ERPs

vary greatly, but can be dissected into two major components: planning and implementation. The planning segment may include goals, objectives, design, incident management system, and means of hazard identification. The ERP implementation section may include prevention and mitigation standards, operational procedures and recordkeeping, damage assessment and incident management, and incident termination and business resumption.

a. Emergency Response Plan Planning

- i. Plan goals and objectives: Any ERP must be underlain with goals and objectives consistent with the plan purpose and scope. Goals should be constructed to insure continual improvement in ERP quality by evaluating ERP effectiveness through drills and exercises, as well as real time emergencies. Goals should be understood throughout the organization and identify clear responsibilities and accountabilities. ERPs may include SMART goals where the goals should be Specific, Measurable, Attainable, Realistic, and Time-bound.
- ii. ERP design: Plan design combines strategies, tactics, vision, policies, goals, required capabilities, detailed risk assessment, and business impact analysis. The planning process must address potential events that could impact personnel, property, the public, or the environment. Design must combine the needs of all stakeholders into a coordinated and coherent plan. Through the use of well-defined procedures, the design can identify, respond to, and manage any emergency. Designs should take into consideration how the quality of emergency management will impact an organization's reputation, ability to conduct business, operations, and relationships with key stakeholders.
- iii. Incident management system: Incident management systems (IMS) should be foundational to every organization's health, safety, regulatory, and environmental policies and procedures. IMSs are used to manage resources during an incident. Resources include facilities, personnel, equipment, communication systems, and pre-determined response procedures. Every incident must be investigated to determine root causes. Incidents must be properly documented, and the organization must measure response and recovery against goals, objectives, and Key Performance Indicators to determine criteria for improvement.
- iv. Hazard identification: Hazard identification (refer to chapter 3 on Risk Management for additional detail on identification and mitigation of potential threats and hazards) is crucial to planning any ERP and key to continual improvement and update. Adequate time, personnel, and resources must be devoted to analyze all operations for routine and non-routine hazards. Once identified, all hazards need to be risk assessed and prioritized with specific procedures developed to avoid, mitigate, and recover from incidents involving such hazards. A hierarchy to deal effectively with a wide range of hazards may address elimination or substitution of tasks or the engagement of additional engineering and administrative controls. The very last barrier is always use of personal protective equipment (PPE). Well-tested and standardized hazard identification systems are available from the safety engineering industry.

b. Emergency Response Plan Implementation

ERPs address personnel and public safety, as well as protection of property and environment. ERPs shall also document assumptions, functional roles and responsibilities, delegation and transfer of authority,

external liaisons, and support required from logistics and supply chain. The implemented plan should consist of a single, integrated plan, but may include sections specific to operations such as:

- i. P&M standards: P&M should be based on hazard identification, risk assessment, business impact, and cost-benefit analysis. Strategies should be built to either prevent specific incidents or mitigate them to limit impact and consequences. Strategies are dynamic with procedures to adjust to changing conditions. See Chapter 3 on Risk Management.
- ii. Operational procedures and recordkeeping: Procedures must be clearly written and designed to protect life, property, and the environment to the maximum extent possible. Procedures need to allow for concurrent activities of response, mitigation, prevention, business continuity, and recovery. Volumes of information, data, updates, exercise and emergency documentation, and audit results must be maintained in a recordkeeping system that protects the security and integrity of the ERP. Systems must provide for ease of maintenance, information retrieval, and back-up. Information retention should be sufficiently beyond facility life to accommodate the possible development of latent issues. Quality records are also required to support needs for subsequent due diligence, training, and possible litigation.
- iii. Situational/damage assessment and incident management: During any emergency, the organization must timely assess the incident so that appropriate response may continually be executed. Complete instructions are to be included in the ERP about how to perform situational/damage assessment of an emergency incident. Some items to be considered are determination of the nature of the emergency, weather, location, and time; threats to life, property and the environment; and appropriate corrective actions. An operations center should be designed and will issue all appropriate directives to manage the incident.
- iv. Incident termination and business resumption: Through effective incident management, the emergency will cease to be a significant threat to life, property, and the environment. Plans should include steps to communicate internally and externally as appropriate, secure the incident area for necessary recovery and remediation activities, and begin the transition from emergency to non-emergency conditions. Business recovery and resumption plans should provide for the restoration of all processes, operations, and communications. The recovery process must be documented. At a minimum, consider issues such as final damage assessment, total operational recovery, supply chain needs, communication protocols with regulators and the public, required additional financial resources, and employee assistance.

c. Training and Education

A critical element of an ERP is a comprehensive, well-integrated, and robust training program. The program should at a minimum include goals, specific training and testing. All involved staff must possess the necessary skills and knowledge to implement, support, and maintain the ERP. An ERP without this component is not complete, nor will it be effective. This component should at a minimum include:

- i. Type and frequency of training: Basic training should be general, broadly covering all topics generic to the operation. Other trainings should be specific to task, location, equipment, roles, responsibilities, hazards, and procedures. All personnel should be thoroughly and routinely trained on all aspects within their roles and responsibilities. Frequency of training

should be driven by regulatory requirements which is typically annually but may vary up to every 3 years, and demonstrating competency. To reach desired levels of competency, more frequent training and exercise may be needed beyond that required by law. Keeping detailed training records should be and often is required by regulation.

- ii. Public education: All emergency responders and other impacted outside agencies need to be thoroughly trained and briefed regarding the specific operations, equipment, hazards, communications, organizations and any other important previous operational issues. The public should be made aware of potential impacts from operational incidents, ERP procedural information, and key communication and organizational structures.

d. Exercises, Program Maintenance, Improvement and Update

Effective execution of ERPs will not occur without frequent and meaningful exercises and drills. At a minimum, these activities should provide opportunities for staff to take action, solve problems, interact with all stakeholders, and deepen their understanding of the ERP. No amount of classroom or tabletop exercises can replace drills and exercises conducted as if a real emergency were taking place.

- i. Frequency and types of exercises and drills: Exercise and drill frequency should be at least annually. More frequent drills may be needed to ensure all stakeholders are well-versed in the ERP and can perform their duties effectively. Types of drills can vary from workshops and tabletops to specific functional drills or full-scale exercises. Plan drills and exercises carefully to cover a variety of situations across the full breadth of operations. Strong consideration should also be given to conducting no-notice exercises. Effective exercises and drills require adequate resources (time, material, planning, and personnel) and a full commitment from all stakeholders, particularly senior leadership. Proper practice is definitely one of the most critical parts of ERP implementation.
- ii. Exercise and drill design: Exercises must be well-designed and executed for maximum value. They must evaluate ERP effectiveness, procedures, and strategy to deal with a broad range of emergencies. All outside agencies should be integrated into the exercise. Exercises should incorporate a standardized template designed to test the ERP performance, post-exercise analysis, lessons learned, and interaction with all stakeholders.
- iii. Total plan review and update: Effective ERPs are dynamic documents and should be thoroughly reviewed and updated at least annually. Other opportunities for improvement, review, and update include exercises and drills, internal and external audit results, changing regulations, organizational modifications, policy and procedural changes, and performance objective refinements. Updates should be timely, follow a sound management of change process, and be immediately communicated internally and to appropriate outside agencies.

Chapter 12

Temporary Abandonment, Well Closure, and Restoration

Introduction

The temporary abandonment, plugging, and restoration of wells associated with the underground storage of gas and other hydrocarbon storage gas operations has been accomplished by the gas storage industry for a many years. Temporary abandonment, well plugging, and restoration requirements can vary extensively between the various state regulatory agencies. Additionally, because of the different types of storage wells (wells in depleted oil and gas horizons, salt caverns, hardrock caverns, and aquifers) consideration of the various methodologies utilized for temporary and permanent abandonment must be evaluated.

Major Issues and Concerns

Perhaps the most critical issue to be addressed is to ensure that by placing the gas storage well into temporary abandonment status or final plugging and abandonment prevents any potential for pathways of gas migration and completely isolates the storage field reservoir from any temporarily or permanently abandoned well. Wells placed into temporary abandonment status still need to demonstrate well integrity, be monitored, be appropriately remediated if necessary, and returned to service, or eventually be permanently plugged and abandoned. While placement of all plugs in a well is important, placement of the first or bottom plug is critical to ensuring that the storage reservoir itself is isolated.

Main Take-Aways

- Temporary abandonment and well closure can be accomplished in a manner that ensures wellbore integrity and prevents those wellbores from serving as pathways for the migration of storage gas.
- Proper well closure and abandonment ensures the integrity of the gas storage reservoir.

Temporary Abandonment, Well Closure, and Restoration

Temporary abandonment of gas storage wells may be considered, but with significant regulatory conditions (including limits on wells remaining in temporary abandonment status) established to ensure that these wells will not present an immediate risk of gas migration out of the gas storage reservoir. Well abandonment designs must ensure that the gas storage cavern or reservoir is isolated long-term from all other porous or hydrocarbon-bearing zones in order to prevent fluid flow or gas migration between the storage zone and any other penetrated formations and the surface. (16) (10) Once the well is plugged and permanently abandoned, the operator should ensure the surface is returned to as near-original condition as is practicable and should follow all applicable regulations and prudent practices.

a. Safety Considerations

A number of safety issues must be considered during testing of temporarily abandoned and/ or permanent plugging and abandonment of gas storage wells. During each phase of the plugging or restorations operations, a job safety analysis should be undertaken prior to any work being conducted. Everyone onsite

has stop work authority. All required PPE should be worn at all times when on location and the appropriate level of safety training should be conducted for anyone that will be on location.

b. Potential Considerations for Porosity Storage (Depleted and Aquifer Storage Reservoirs)

- i. Wellhead control considerations and capabilities;
- ii. Protection of USDWs or other protected groundwater;
- iii. The many potential wellbore issues – corrosion zones, flow zones, lost circulation zones, disposal zones, commercial hydrocarbon-bearing horizons, lost fish, casing patches, liners, junk, etc.;
- iv. Directionally drilled wells;
- v. Preparation for working with pressures anticipated from an existing storage reservoir and potential pressures and flows from uphole formations currently behind pipe that may be exposed to the wellbore if pipe is pulled;
- vi. Well integrity and other pressure testing; and
- vii. Open-hole and cased hole geophysical logging considerations.

c. Temporary Abandonment Well Considerations for Porosity Storage

- i. Develop a plan to prevent migration pathways and isolate the storage reservoir in compliance with regulatory requirements;
- ii. Time considerations and notifications;
- iii. Well testing and monitoring during temporary abandonment;
- iv. Well workovers and corrective action;
- v. Temporary abandonment status vs. “idle” well status – identify the differences; and
- vi. Reporting requirements.

d. Plugging and Abandonment Well Considerations for Porosity Storage

- i. General requirements and considerations
 1. Plugging permit, closure plan, or other authorization, if required; and
 2. Regulatory review, requirements, and notifications.
- ii. Wellhead design considerations
 1. Blow-out protection and well control; and
 2. Snubbing or swabbing valve on production casing.

- iii. Plugging methods, considerations and regulatory requirements
 - 1. Removal of all downhole equipment;
 - 2. Setting of initial bottomhole plug – cement vs. mechanical or both – consideration of pressure testing to ensure isolation of gas storage reservoir;
 - 3. Additional cement plug requirements – casing shoes, casing rips, lost circulation, flow zones, commercial hydrocarbon-bearing zones, corrosion zones, other mineral zones (coal and others), USDWs or other protected groundwater, and surface plugs;
 - 4. Staging of cement vs. bullhead cement jobs;
 - 5. Cement types, additives, quality, and quantity;
 - 6. Wait-on-cement time, pressure testing, and tagging plugs;
 - 7. Plug spacer considerations;
 - 8. Casing recovery (when possible and not cemented to surface);
 - 9. Geophysical logging considerations;
 - 10. Groundwater monitoring considerations; and
 - 11. Submittal of plugging and abandonment report.

e. Restoration of Site for Porosity Storage Wells

- i. Removal of wellhead and wellhead equipment;
- ii. Cut off casing below grade (below plow depth if required);
- iii. Tack weld steel plate with API or other identification information/number;
- iv. Restoration of the area around the well; and
- v. Records retention considerations.

f. Potential Issues for Salt Cavern Storage Wells

- i. Wellhead control capabilities;
- ii. Protection of USDWs or other protected groundwater;
- iii. Addressing the many wellbore issues – corrosion zones, flow zones, lost circulation zones, disposal zones, commercial hydrocarbon-bearing horizons, lost fish, casing patches, liners, junk, and others;
- iv. Directionally drilled wells;
- v. Preparation for working with pressures anticipated from the existing gas storage reservoir;
- vi. Well integrity and other pressure testing; and
- vii. Geophysical logging considerations.

g. Temporary Abandonment Well Considerations for Salt Cavern Storage

- i. Develop a plan for agency approval to prevent migration pathways and isolate the storage cavern;
- ii. Time considerations and notifications;
- iii. Well testing and monitoring during temporary abandonment – maintain a minimum pressure for stability, monitor pressure;
- iv. Temporary abandonment status vs. “idle” well status – identify the differences;
- v. Reporting requirements include appropriate monitoring data such as pressures. Report significant activities in regards to the well. Determine an appropriate reporting frequency;
- vi. Implement measures in regards to wellhead equipment to prevent inadvertent use of the well for storage; and
- vii. Submit plan for agency approval for returning well to service.

h. Plugging and Abandonment Well Considerations for Salt Cavern Storage

- i. General requirements and considerations
 1. Review well construction, operational, monitoring, testing and logging information.
 2. Develop a closure plan submitted to the regulatory agency for review and consideration of approval. Plugging permit, closure plan, or other authorization if required;
 3. Regulatory review, requirements, and notifications;
 4. Wellhead design considerations;
- ii. Plugging methods and requirements
 1. Blow-out protection and well control;
 2. Snubbing or swabbing valve on production casing;
 3. Removal of all downhole equipment;
 4. Prior to abandonment, removal of all gas to the extent possible through displacement of brine; (11)
 5. The cavern must be filled with saturated brine to assist in maintaining cavern stability.
 6. Conduct geophysical logging/ cavern surveys. Considerations include - gamma ray, cement bond, temperature, casing inspection logs, and sonar survey;
 7. Set initial bottomhole plug – must be a mechanical bridge plug set at the deepest location within the production casing to both properly isolate the cavern and not damage the casing – performance of pressure testing to ensure isolation of gas storage reservoir and then place cement plug on top of the mechanical plug;
 8. Additional cement plug requirements – casing shoes, casing rips, loss circulation zones, flow zones, commercial hydrocarbon-bearing zones, corrosion zones, other mineral zones (coal and others), USDWs or other protected groundwater, and surface plugs;

9. Staging of cement;
10. Cement types, additives, quality, and quantity considerations;
11. Wait-on-cement time, pressure testing, and tagging plugs;
12. If there is a fall back of cement inside the production casing at the surface, the casing must be topped off to the surface with cement.
13. Plug spacer considerations – if allowed. It is recommended that if feasible the well casing be filled with cement from bottom to surface;
14. Casing recovery (when possible and not cemented to surface);
15. Consideration for well and cavern to be at state of static equilibrium prior to plugging and abandonment ;
16. Submittal of plugging and abandonment report; and

i. Restoration of Salt Cavern Storage Wells

- i. Remove wellhead equipment;
- ii. Tack weld steel plate with API, or other identification information/ number;
- iii. Leave casing top accessible and incorporate into monument grid for subsidence monitoring;
- iv. Continue groundwater monitoring; and
- v. Records retention must meet agency requirements, must be maintained for a period of time until satisfied there are no problems with the well/cavern.

j. Potential Considerations for Hard Rock Cavern Storage Wells

- i. Typically, hard rock caverns are normally relatively shallow;
 - ii. Wellhead control considerations and capabilities;
 - iii. Operating pressures in the cavern system are intended to keep the stored product in a liquid phase. Depending on the cavern depth and the stored product, these pressures are typically in the range of 20 to 125 psi. A loss of this operating pressure can result in a rapid transformation of liquid into gas;
 - iv. Protection of USDWs or other protected groundwater is accomplished during the initial installation of operational and venting wells installed to perform mining operations. Not only is the USDW or other protected groundwater protected but the casing program prevents groundwater invasion into the mine;
 - v. Addressing any wellbore issues – corrosion zones, flow zones, lost circulation zones, lost fish, liners, and junk, etc.;
 - vi. Well integrity and other pressure testing;
 - vii. Geophysical logging considerations; and
 - viii. Favorable conditions for adequate hydraulic containment.
-

k. Temporary Abandonment Well Considerations for Hard Rock Cavern Storage

- i. Develop a plan for prevention of migration pathways and isolation of the storage reservoir. Prior to temporarily abandoning a mined cavern, the stored liquid must be removed and the cavern filled with an inert gas or liquid. To ensure the cavern has been rendered completely inert, the operator may conduct and submit chemical analyses of the storage fluids to the regulatory agency for review. The inert gas can also assist with recovery of both the liquid and gas phases in the cavern. The inert gas is used to maintain positive pressure (100 plus psi depending on depth or the minimum pressure determined by a rock mechanical properties assessment) (53) on the cavern to support the pillars and prevent collapse of the cavern. The inert gas pressure can be monitored at the surface as a possible indicator of migration from either the cavern itself or from one (or more) of the access points.
- ii. Time considerations and notifications
The length of time necessary to render inert any cavern will depend on the product volume and market. For example, an operator may have difficulty making a propane cavern inert in July due to market demand. The regulatory agency (federal or state) with responsibility for mined cavern operations is notified when a cavern or caverns are taken out of service.
- iii. Well testing and monitoring
When a cavern is temporarily abandoned, the pressure in the access wells is monitored continuously with any significant change in pressure reported within 48 hours. The pressure is used to support the cavern roof and pillars and the loss of pressure could result in catastrophic failure of the cavern. Integrity testing of the access wells (and other conveyances) may be confirmed before beginning large scale product evacuations and again once the cavern is confirmed to be inert.
- iv. Temporary abandonment status vs. “idle” well status – identifying the differences
- v. Reporting requirements: The owner/operator of the cavern reports pressure measurements on a quarterly basis for any and all access wells.

I. Plugging and Abandonment Well Considerations for Hard Rock Cavern Storage

Prior to abandoning a hard rock cavern, the cavern should be evacuated, to the extent practicable, of all hydrocarbons. The plugging and abandoning of a mined cavern storage operation requires that the abandonment of the cavern be considered as well as the abandonment of any and all wells that provide access to the cavern. Caverns can be abandoned by filling with an appropriate inert gas or potentially other fluid. The depth of the cavern and any potential communication with the local USDWs or other protected groundwater will dictate the appropriate material. Typically, one or more large diameter boring(s) (60 inches or greater) provides the initial entry to begin mining operations. A single casing string is installed in this boring to the roof of the proposed mine and is either grouted or cemented in place. This casing string provides future access to the mine as well as providing protection of the USDW or other protected groundwater. Subsequent to the completion of the mining operation, additional smaller diameter wells are drilled and cased to provide additional points to place or remove the stored hydrocarbons.

A permit to mine the cavern may have been issued by the federal or state agency with authority over underground mining. The permit to drill the access wells may have been issued by the federal or state agency with authority over drilling. The abandonment of any well permitted to drill should obtain a permit to plug.

The regulatory agency – federal or state – with the authority to permit the mining portion of the operation may require application and review of any plan to abandon the mine and notification when the activity is scheduled to occur. The regulatory agency – federal or state – with the authority to permit any drilling, casing or cementing associated with cavern operation will review any proposal to abandon a permitted operation. The agency may require appropriate prior notification to allow for site inspection and or witnessing.

An operator should develop a plugging and abandonment plan that includes:

- i. Demonstration of the stability of all caverns being abandoned with geomechanical analysis and pressure build-up;
 - ii. Removal of all downhole equipment and uncemented casing strings, unless circumstances prohibit their removal;
 - iii. Complete isolation from all other porous and permeable zones or hydrocarbon-bearing formations.
 - iv. Wellhead design considerations
 - v. Plugging and abandonment procedures;
 - vi. Blow-out protection and well control;
 - vii. Snubbing or swabbing valve on production casing;
 - viii. Setting of initial bottomhole plug, which must include a mechanical plug and then consideration of pressure testing of the mechanical plug to ensure isolation of gas storage reservoir;
 - ix. Mechanical bridge plugs can be set inside the smaller diameter access wells near the base of the casing where good cement bond exists between the casing and the formation. Once the bridge plug is set, 100 feet of cement is usually placed on the plug with tubing and allowed to cure long enough to reach a prescribed compressive strength. A cement bond log should be run on access wells to ensure that the cement sheath provides adequate hydraulic isolation of the casing/formation annulus;
 - x. Cement should be spotted with tubing or work string and stage cemented to surface;
 - xi. Cement types, additives, quality, and quantity considerations;
 - xii. Wait-on-cement, pressure testing, and tagging plugs;
 - xiii. A written closure or plugging report summarizing the plugging activities may be submitted to the permitting authority. The report identifies the plugging method, materials, equipment and results. Supporting documentation in the form of contractor reports, invoices and/or job summaries may also accompany the plugging report; and
 - xiv. Potential groundwater monitoring considerations.
-

m. Restoration of Hard Rock Cavern Wells

- i. Remove wellhead equipment; (57)
- ii. Tack weld of steel plate with API or other identification information/ number;
- iii. Leave casing top accessible and incorporate into monument grid for subsidence monitoring; and
- iv. Records retention requirements.

Appendix A

List of References

1. **U.S. Department of Energy.** *Ensuring Safe and Reliable Underground Natural Gas Storage: Final Report of the Interagency Task Force on Natural Gas Storage Safety.* s.l. : U.S. Department of Energy, October, 2016.
2. **IOGCC, Energy Resource, Technology, and Research Committee.** *Hydrocarbon storage in mined caverns: A guide for State regulators.* 1998. p. 38.
3. **U.S. EIA.** [Online] 2015. https://www.eia.gov/cfapps/ngqs/ngqs.cfm?f_report=RP7.
4. **Clark, James A.** *The Chronological History of the Petroleum and Natural Gas Industries.* Houston : Clark Book Co., 1963.
5. **Natural Gas Supply Association.** Storage of Natural Gas. [Online] January 28, 2013. <http://naturalgas.org/naturalgas/storage>.
6. **British Geological Survey.** *An Appraisal of Underground Gas Storage Technologies and Incidents for the Development of Risk Assessment Methodology, RR^)%.* s.l. : Health and Safety Executive, 2008.
7. **Lord, Anna S.** *Overview of Geologic Storage of Natural Gas with an Emphasis on Assessing the Feasibility of Storing Hydrogen.* s.l. : Sandia National Laboratories, SAND200-5878, 2009.
8. **J. Reed, Leyden Coal Mine.** [Online] [Cited: April 18, 2016.] http://www.rockware.com/vt/leydon_coal_mine.html.
9. **U.S. EIA.** Natural Gas Annual Respondent Query System (EIA 191) Date through 2015. *191 Field Level Storage Data (Annual) -2005 and 2015.* [Online] 2016. [Cited: June 2016, 2016.] http://www.eia.gov/cfapps/ngqs/ngqs.cfm?f_report=RP7&f_sortby=ACI&f_items=&f_year_start=2005&f_year_end=2015&f_show_compид=Name.
10. **API.** *RP 1171 Functional integrity of natural gas storage in depleted and aquifer reservoirs, API RP 1171, First Edition.* s.l. : API, September 2015.
11. **IOGCC, Energy Resources Committee.** *Natural gas storage in salt caverns: A guide for State regulators.* 1998. p. 45.
12. *Preliminary SED Staff Whitepaper on As Low As Reasonably Practicable (ALARP) Risk-informed Decision Framework Applied to Public Utility Safety.* Haine, Stephen. 2015.
13. **API.** *RP 1114 Recommended Practice for the Design of Solution-mined Underground Storage Facilities, First Edition.* 1220 L St. NW, Washington D.C. : API Publishing Services, 1994.
14. **NYDEC.** *Generic Environmental Impact Statement on the Oil, Gas and Solution Mining Regulatory Program.* New York Department of Environmental Conservation. [Online] [Cited: February 2, 2017.] <http://www.dec.ny.gov/energy/45912.html>.

15. **Kansas, State of.** K.A.R. 82-3-311.
16. **CSA.** *Storage of hydrocarbons in underground formations*, 2341 Series- 14, 138 P. s.l. : Canadian Standards Association, August, 2014.
17. **API.** *RP 1170 Design and Operation of Solution-mined Salt Caverns Used for Natural Gas Storage, API RP 1170, First Edition.* s.l. : API, July 2015.
18. —. *RP 6A Specification for wellhead and Christmas tree equipment, 20th edition.* s.l. : API, October 2011.
19. —. *RP 10A Specification for Cements and Materials for Well Cementing, 24th Edition.* s.l. : API, 2010.
20. *Rock engineering problems related to underground hydrocarbon storage.* **Lu, Ming.** 2010, Journal of Rock Mechanics and Geotechnical Engineering, Volume 2, Issue 4, pp. 289-297.
21. *Well Integrity Workshop.* **Arthur, J. D. and Casey, Greg.** Sarasota : s.n., January, 2012. GWPC Annual UIC Conference.
22. **USEPA Region 5.** *Determination of The Mechanical Integrity of Injection Wells*, Rev. ed. February, 2008.
23. *A Study of the Orifice Well Tester and Critical Flow Prover.* **Lesem, Louis B., McKetta, John J. Jr. and Fancher, George H.** September 1957, Journal of Petroleum Technology, o, no. 9, pp. 61-64.
24. **British Columbia Oil and Gas Commission.** *Well Completion, Maintenance and Abandonment Guideline, Version 1.18.* September 2015.
25. *The Structure and Interpretation of Noise from Flow behind Cemented Casing.* **McKinley, R. M., Bowler, F. M. and Rumble, R. C.** March 1973, Journal of Petroleum Technology 25, no. 3, pp. 269-278.
26. **McKinley, R. M.** *Temperature, Radioactive Tracer, and Noise Logging for Injection Well Integrity.* July, 1994.
27. *A Practical Approach to the Interpretation of Cement Bond Logs.* **Bigelow, E.L.** July 1985, Journal of Petroleum Technology 37, no. 7, pp. 1285-1294.
28. **Schlumberger, Inc.** *Cement Evaluation.* s.l. : Schlumberger Educational Services, 1989.
29. *Cementing, Henry L. Doherty Series, v. 4 (H.L. Doherty Memorial Fund of AIME).* **Smith, Dwight K.** New York : Society of Petroleum Engineers, 1990.
30. *Overview on underground storage of natural gas.* **Katz, D. L. and Tek, M. R.** 1981, Journal of Petroleum Technology 33, pp. 943-951.
31. *Analysis of fault leakage from Leroy underground natural gas storage facility, Wyoming, USA.* **Chen, M., et al.** 2013, Hydrogeology Journal 21, pp. 1429-1445.
32. *Three-dimensional geologic model of the Pecatonica gas storage field, Winnebago County, Illinois.* **Kron, N. D. and Maline, D. H.** 2015, World Journal of Environmental Engineering 3, pp. 121-125.

33. **Evans, D. J.** *A review of underground fuel storage events and putting risk into perspective with other areas of the energy supply chain*, In *Underground gas storage: Worldwide experiences and future development in the UK and Europe*. [ed.] D. J. Evans and R. A. Chadwick. s.l. : Geological Society: London, 2009. pp. 173-216.
34. **United Nations Economic Commission for Europe.** *Study on underground gas storage in Europe and Central Asia*. Geneva, Switzerland : United Nations, 2013.
35. *Analysis of major risks associated with hydrocarbon storage caverns in bedded salt rock*. **Yang, C., et al.** 2013, *Reliability Engineering and System Safety* 113, pp. 94-111.
36. *Geomechanical challenges in petroleum reservoir exploitation. KSCE Journal of Civil Engineering 15; Schultz, R.A., Mutlu, U., Bere, A. (2016) Critical issues in subsurface integrity Paper ARMA 16-37. Dusseault, M.B. Houston : s.n., 2016. 50th US Rock Mechanics/ Geomechanics Symposium. pp. 669-678.*
37. **Ghassemi, A.** *A review of some rock mechanics issues in geothermal reservoir development. Geotechnical and Geological Engineering* 30. 2012. pp. 647-664.
38. *Estimating fault stability and sustainable fluid pressures for underground storage of CO₂ in porous rock*. **Streit, J. E. and Hillis, R. R.** *Energy* 29, pp. 1445-1456.
39. *The geomechanics of CO₂ storage in deep sedimentary formations*. **Rutqvist, J.** 2012, *Journal of Geotechnical and Geological Engineering* 30, pp. 525-551.
40. *Earthquake triggering and large-scale geologic storage of carbon dioxide*. **Zoback, M. D. and Gorelick, S. M.** 2012. *Proceedings of the U.S. National Academy of Science* 109. pp. 10,164-10,168.
41. *Recent advances in risk assessment and risk management of geologic CO₂ storage*. **Pawar, R. J., et al.** 2015, *International Journal of Greenhouse Gas Control* 40, pp. 292-311.
42. *Thesis—keeping the management system ‘live’ and reaching the workforce Paper SPE 36034*. **Primrose, M. J., Bentley, P. D. and Van der Graff, G. C.** New Orleans, LA : s.n., 1996, *Journal of Petroleum Technology*, Vol. SPE 36034, p. 19.
43. *Ten golden rules for developing robust bowties*. **Ramsden, M., et al.** London, UK : s.n., April, 2013. SPE European Health, Safety, Environment, and Social Responsibility in Oil and Gas Exploration Conference and Exhibition.
44. *Cavern storage of liquified natural gas. Paper WPC-12534*. **Khan, A. R., Anderson, P. J. and Eakin, B. E.** Mexico City : s.n., April, 1967. 7th World Petroleum Congress.
45. *Civil reuses of underground mine openings: A summary of international experience*. **Peila, D. and Pelizza, S.** 1995, *Tunneling and Underground Space Technology* 10, pp. 179-191.
46. *Ohio seeks US guidance on storage caverns*. **Cromwell, L.** March 6, 2013, *CantonRep.com*.
47. **PB-KBB, Inc.** *Advanced underground gas storage concepts: Refrigerated-mined cavern storage. Final Report to USDOE, contract number DE-AC26-97FT34349*. 1998.
-

48. *Underground gas storage in the Leyden lignite mine*. **Meddles, R. M.** 1978. 1978 Symposium on Energy Resources of the Denver Basin, Rocky Mountain Association of Geologists. pp. 51-59.
49. *The water curtain: A successful means of preventing gas leakage from high-pressure, unlined rock caverns*. **Kjorholt, H. and Broch, E.** 1992, Tunneling and Underground Space Technology 7, pp. 127-132.
50. **Folga, S., et al.** *U.S. natural gas storage risk-based ranking methodology and results*. s.l. : Argonne National Laboratory Technical Report ANL-16/19, 2016.
51. *Safety of salt caverns used for underground storage*. **Berest, P. and Brouard.** s.l. : Oil & Gas Science and Technology, 2003, Vol. Rev. IFP 58.
52. **Bruno, M. S., et al.** *Development of improved caprock integrity analysis and risk assessment techniques*. Energy Procedia 63: 4708-4744. 2014.
53. **Nemec, R.** *California's second-largest gas storage field closed for leak repair*. NGI's Daily Gas Price Index. 2016.
54. *Safe storage of CO₂: Experience from the natural gas storage industry*. **Papanikolau, N., et al.** Trondheim, Norway : N.A. Rokke et al., Editors, 2006. 8th International Conference on Greenhouse Gas Control Technologies. Vols. Abstracts volume, June 19-22, 2006.
55. *Well blowout rates in California oil and gas District 4: Update and trends*. **Jordan, P.D. and Benson, S.M.** s.l. : Exploration and Production: Oil and Gas Review, Vols. Paper LBNL-2989E.
56. **Hubbard, D.W.** *The failure of risk management: Why it's broken and how to fix it*. New York : Wiley, 2009.
57. ISO. 55000 Asset management- Overview, principles and terminology, 1st Edition. s.l. : International Standards Organization, January 15, 2014.
58. Pacific Gas & Electric. [Online] <http://www.pgecurrents.com/2016/02/05/pge-safely-operates-its-natural-gas-storage-facilities>.
59. **API.** *RP 1114 Recommended Practice for the Design of Solution-mined Underground Storage Facilities, Second Edition*. 1220 L. St., NW, Washington D.C. : API Publishing Services, 2013.
60. —. *RP 1115 Recommended Practice for Operation of Solution-Mined Underground Storage Facilities, First Edition*. s.l. : API Publishing Services, 1220 L. St. NW, Washington D.C., 1994.
61. *Subsurface containment assurance program—Key element overview and best practice examples, Paper OTC 24851; Pawar et al. 2015, ref. 9*. **Schultz, R. A., et al.** Kuala Lumpur, Malaysia : s.n., March, 2014. Off-shore Technology Conference Asia.
62. *Geomechanical technology for seal integrity analysis- The three-step approach Paper IPTC 17057*. **Davidson, J.M., et al.** Beijing : s.n., 2013. International Petroleum Technology Conference.
63. Monitoring and induced seismicity from underground gas storage: First steps in Italy, Paper EGU 2013-12375. **Mucciarelli and Priolo.** Vienna, Austria : s.n., 2013. EGU General Assembly.

64. **Jaeger, J.C., Cook, N.G.W. and Zimmerman, R.W.** *Fundamentals of Rock Mechanics, Fourth Edition*. s.l. : Blackwell Publishing, 2007.
65. *Use of natural gas compositional tracers to investigate gas migration from a gas storage field*. **Saba, T. and Boehm, P.D.** s.l. : Environmental Geosciences 19(2): 1-12, 2012.
66. *Eminence Dome- Natural-Gas Storage In Salt Comes of Age, SPE 3433-PA*. **Medley, A.H.** s.l. : Journal of Petroleum Technology Vo. 24 No. 11, 1975.
67. **Hilbert, L.B. and Saraf, V.K.** *Salt mechanics and casing deformation in solution-mined gas storage operations, Paper ARMA 08-383*. San Francisco, CA : 42nd U.S. Rock Mechanics Symposium and 2nd U.S.-Canada Rock Mechanics Symposium, 2008.
68. *Geomechanical response to season gas storage in depleted reservoirs: A case study in the Po River basin, Italy*. **Teatini, et al.** F02002, doi: 10.1029/2010JF001793, s.l. : Journal of Geophysical Research, 2011, Vol. 116.
69. **API.** *RP 100-1 Hydraulic Fracturing-Well Integrity and Fracture Containment, 1st Edition*. s.l. :API, October 1, 2015.
70. —. *RP 14B Design, Installation, Operation, Test, and Redress of Subsurface Safety Valve Systems, 6th Edition*. s.l. : API, September 1, 2015.
71. **ISO.** *22301 Societal security- Business continuity management systems- Requirements, 1st Edition*. s.l. : International Standards Organization, May 15, 2012.
72. **CSA.** *Z731-03 Emergency Preparedness and Response*. s.l. : Canadian Standards Association, 2014.
73. **NFPA.** *1600: Standard on Disaster/ Emergency Management and Business Continuity/ Continuity of Operations Programs*. s.l. : National Fire Prevention Association, 2016.
74. **IOGCC, Energy Resources Committee.** *Natural Gas Storage in Salt Caverns: A Guide for State Regulators*. p. 16.
75. *Comment on 'Methane Emissions from Process Equipment at Natural Gas Production Sites in the U.S.: Pneumatic Controllers*. **Howard, Touche.** 2015, Environmental Science & Technology 49 (6), pp. 3981-3982.
76. *The status quo and technical development direction of underground gas storages in China*. **Ding, G., et al.** 2015, Natural Gas Industry B2, pp. 535-541.
77. **Benson, Robert, et al.** *Standoff Passive Optical Leak Detection of Volatile Organic Compounds Using a Cooled InSb Based Infrared Imager*. In. *Vo. Paper 06-A-131*. New Orleans, LA : s.n., 2006.
78. **USDOT, PHMSA [Docket No. PHMSA-2016-0016]** . *Pipeline Safety: Safe Operations of Underground Storage Facilities for Natural Gas, Notice; Issuance of Advisory Bulletin (ADB-2016-02)*. Washington D.C. : U.S. Federal Register, February 2016. pp. 6334-6336.

79. *Induced seismicity from underground gas storage: First steps in Italy*. Vienna : s.n., 2005. EGU2013-12375 presented at EGU General Assembly, 7-12 April 2013. pp. 37-38.

80. **Bacharach, Inc.** *Bacharach Hi-Flow Sampler, Instruction 0055-9017, Operation and Maintenance*. s.l. : Bacharach, Inc., 2015.

81. Asset Management Standards. [Online] <http://www.assetmanagementstandards.com/iso-55000-standards-for-asset-management/>.

82. **International Association of Oil and Gas Producers.** *Asset integrity: the key to managing major incident risks*. 2008.

83. **Gas Processors Association Midstream Association.** [Online] <https://www.gpaglobal.org/knowledge-center/midstream-operations>.

84. **Allen, David T., Sullivan, David W. and Harrison, Matt.** *Response to Comment on Methane Emissions from Process Equipment at Natural Gas production Sites in the U.S.: Pneumatic Controllers*. s.l. : Environmental Science & Technology 49(6): 3983-84. doi:10.1021/acs.est.5b00941.

85. *Overview on underground storage of natural gas.* **Katz, D. L. and Tek, M. R.** 1981, Journal of Petroleum Technology 33, pp. 943-951.

Appendix B

List of Acronyms

Acronym	Meaning
ALARP	As Low as Reasonably Practical
AOR	Area of Review
API	American Petroleum Institute
CBL	Cement Bond Log
CBLs	Cement Bond Logs
CET	Cement Evaluation Tool
CFR	Code of Federal Regulations
CPET	Corrosion Protection Evaluation Tool
CSA	Canadian Standards Association
EM	Electromagnetic Casing Inspection Log
ERP	Emergency Response Plan
ERPs	Emergency Response Plans
FERC	Federal Energy Regulatory Commission
GWPC	Ground Water Protection Council
IFR	Interim Federal Rule
IR	Infrared
IOGCC	Interstate Oil and Gas Compact Commission
ISO	International Organization for Standardization
LEL	Lower Explosive Limit
LPG	Liquid Petroleum Gas
MIT	Mechanical Integrity Test
MAOP	Maximum Allowable Operating Pressure
MOU	Memorandum of Understanding
P&M	Preventative and Migration
PAS	Publicly Available Standard
PHA	Process Hazard Analysis
PHMSA	Pipeline and Hazardous Materials Safety Administration

Acronym	Meaning
PPE	Personal Protective Equipment
RCBL	Radial Cement Bond Log
RMP	Risk Management Plan
RMPs	Risk Management Plans
RP	Recommended Practice
SCADA	Supervisory Control and Data Acquisition system
SAPT	Standard Annulus Pressure Test
SBT	Segmented Bond Tool
UGS	Underground Gas Storage * (Includes underground storage of natural gas and natural gas liquids unless otherwise noted)
USDOE	U.S. Department of Energy
USDOT	U.S. Department of Transportation
USEIA	U.S. Energy Information Administration
USEPA	U.S. Environmental Protection Agency
USDW	Underground Source of Drinking Water
USIT	Ultrasonic Imager Tool

Appendix C

List of Terms

Term	Meaning
Abandonment	The final closure of a well following plugging
Annulus	The space between a casing string and the wellbore, between two casing strings or between tubing and casing
Area of Review	The review of a specified area around a well or defined storage reservoir or cavern
Buffer zone	The region surrounding an underground storage facility within the Area of Review within which observation wells and other monitoring strategies are deployed to detect undesired fluid movement. Defined similarly in API RP 1171
Christmas tree	An assembly of valves, spools, pressure gauges and chokes fitted to the wellhead of a completed well to control production.
Confining Zone/ Caprock Sequence	The stratigraphic layers located above or around the reservoir, often including shales and other lower-permeability rock types that separate the reservoir from areas such as groundwater aquifers, other producing formations, and the ground surface. Referred to as “caprock” in API RP 1170 and 1171.
Containment	Retention of subsurface fluids in their intended wellbores or subsurface zones, such as the reservoir; the desired state for underground gas and liquids storage. Defined similarly in API RP 1171.
Gas	Means natural gas and liquid petroleum gas (LPG) unless otherwise noted
Idle well	A well that is not being used for its intended purpose but which is not plugged or formally temporarily abandoned
Intermediate casing	A casing string set between the surface casing and production casing
Isolation valve	The first valve in a gathering line that is located beyond the wellhead and which could be used to isolate the well
Leakage	Unintended or undesired movement of subsurface fluids into locations such as groundwater aquifers, other producing formations, or the ground surface; corresponds to a loss of containment.

Term	Meaning
Movement	Relocation of subsurface fluids into wellbores or other stratigraphic units; can be intentional (i.e., injection and withdrawal) or unintentional (i.e., reservoir fluids moving through the confining zone/caprock sequence).
Monitoring well	A well drilled into the gas storage zone used to monitor the movement and pressure of the gas stored in the zone
Pipeline	A tube or system of tubes used for transporting crude oil and natural gas from the field or gathering system
Plugging	The permanent sealing of a wellbore with materials designed to prevent the vertical migration of fluids (e.g. cement, bridge plugs)
Production casing	The casing string through which the production of hydrocarbons is achieved
Restoration	The return of a wellsite to the conditions that existed prior to drilling and production
Significant	The amount of change that would be considered unusual under normal operational practices and conditions
Spill point	The structurally lowest point in a <u>hydrocarbon</u> trap that can retain hydrocarbons.
Surface casing	The casing string set through fresh water zones for the protection of groundwater
Temporary abandonment	A well that is in a non functioning condition under an authorization from a regulatory agency
Wellhead	The surface termination of a wellbore that incorporates facilities for installing casing hangers during the well construction phase
Workover	The process of performing major maintenance or remedial treatments on an oil or gas well.

Acknowledgements

The States First Initiative would like to acknowledge the following individuals for their contributions to this guide. (Listed alphabetically by group)

Development Leadership Team

Tim Baker, Director, Oil and Gas Division, Oklahoma Corporation Commission
Diana Burn, Eastern Engineering Supervisor, Colorado Oil and Gas Conservation Commission
Hal Fitch, Chief, Office of Oil, Gas, and Minerals, Michigan Department of Environmental Quality (Co-chair)
Ryan Hoffman, Director of Oil and Gas, Kansas Corporation Commission
Virginia Hullinger, Technical Services Manager - Oil and Gas Division, Oklahoma Corporation Commission
Rick Simmers, Chief, Division of Oil and Gas Resources, Ohio Department of Natural Resources (Co-chair)
Michael Sims, Engineer, Technical Permitting, Oil and Gas Division, Railroad Commission of Texas
Alan Walker, Supervising Oil and Gas Engineer, Division of Oil, Gas and Geothermal Resources, California Department of Conservation

Contributing Authors

Andrew Adgate, UIC Manager, Division of Oil and Gas Resources, Ohio Department of Natural Resources
Jacob Isaac K. Abraham, Storage Reservoir Engineer, Dominion Energy
Andrew Adgate, UIC Manager, Division of Oil and Gas, Ohio Dept. of Natural Resources
Tom Alexander, Consulting Engineer, Environmental Defense Fund
Scott Anderson, Senior Policy Director, U.S. Climate and Energy Program, Environmental Defense Fund
Dan Arthur, President, ALL Consulting
James Bolander, President, JLB Engineering, L.L.C.
Alan Brannon, Consulting Engineer, Dominion Transmission
Vivian Chou, Division of Oil, Gas and Geothermal Resources, California Department of Conservation
Mike Cochran, Chief, Geology and Well Technology Section, Kansas Department of Health and Environment
Dan Collins, Senior Principal Geologist, GeostockSandia, LLC
Jessica Crossman, Chief, Underground Hydrocarbon Storage Unit, Kansas Department of Health and Environment, Bureau of Water/ Geology and Well Technology Section
Phil Gibicar, Associate Oil and Gas Engineer, California Department of Conservation
L. Brun Hilbert, Jr., Ph.D., Principal Engineer, Exponent Failure Analysis Associates
John Kearney, Environmental Resource Analyst - Office of Oil and Gas, West Virginia Department of Environmental Protection
Jeff Kennedy, Senior Geologist, ALL Consulting
Kurt Loeff, Senior Principal Geologist, GeostockSandia, LLC
Berne Mosley, BSCE, Energy Projects Consulting, LLC
Gregg Parsons, Director of Functional Safety Technology, United Electric Controls
Adam Peltz, Senior Attorney, U.S. Climate and Energy, Environmental Defense Fund
Bob Pilko, Strategic Director, Blade Energy Partners
Avideh Razavi, Southern California Gas Company, Storage Risk Management
Teresa Rougon, Geologist DCL, Louisiana Office of Conservation
Richard A. Schultz, Ph.D., Senior Research Scientist- Overburden 7 Reservoir Geomechanics, University of Texas at Austin, Center for Petroleum and Geosystems Engineering

Gene Smith, Assistant Chief - Permitting, Office of Oil and Gas, West Virginia Department of Environmental Protection

Tom Tomastik, Senior Geologist and Regulatory Specialist, ALL Consulting

Robert F. Van Voorhees, Executive Director, Underground Injection Technology Council

Tom Williams, Senior Advisor, Environmentally Friendly Drilling

Robert Worstall, Deputy Chief, Division of Oil and Gas Resources, Ohio Department of Natural Resources

Daniel Wynne, Associate Oil and Gas Engineer, Division of Oil, Gas and Geothermal Resources, California Department of Conservation

Independent Review Team

Grant Bromhal, Ph.D., U.S. Dept. of Energy, HQ, Office of Fossil Energy

Candace Cady, Utah Division of Water Quality, Underground Injection Control (UIC) Program

Joe Carmer, Phillips 66, Cavern Engineer

Catherine Foerster, Commissioner, Alaska Oil and Gas Conservation Commission

Mathieu Fournier, Vice President, Engineering & Operations, Niska Gas Storage

Doug Johnson, Senior Director, Economics/FTI Platt Sparks

Noah Matthews, USDOT, PHMSA, SW Region, Engineer (Inspector)

John McLennan, Ph.D., Department of Chemical Engineering, University of Utah

Berne Mosley, President, Energy Projects Consulting

Andy Theodos, Consultant, INGAA

Staff Support

Gerry Baker, Associate Executive Director, Interstate Oil and Gas Compact Commission

Carol Booth, Communications Manager, Interstate Oil and Gas Compact Commission

Amy Childers, Federal Projects Manager, Interstate Oil and Gas Compact Commission

Mike Nickolaus, Special Projects Director, Ground Water Protection Council

