

# Environmental

# Permit Assistance Guide

*An Overview for Oklahoma Industry,  
Business and Water Authorities*



Revised April 2026



Oklahoma City



# I. Introduction

The Oklahoma Department of Environmental Quality (DEQ) was created in 1993 as the state's primary environmental regulatory agency to administer programs protecting Oklahoma's air, land, and water resources. DEQ adheres to statutes, regulations, rules, and guidelines that direct the agency to adopt a posture that is focused on customer service.

Over the past two decades DEQ's Customer Assistance Program (CAP) established itself as a leader among state agencies that took the initiative to reach out to both small and large businesses alike as well as welcoming new facilities starting up in our state. The program is now part of the Permit Assistance & Public Outreach Team (Permit Assistance or PAPOT) that guides companies through the state permitting process, and now, takes on a new role as facilitator for the public engagement process to ensure a professional standardized turnkey approach to get through the process and quickly on to what you are all about, the safe clean operation of your facility!

Permit Assistance will help with determining what permits are needed to construct and operate. DEQ permitting has authorization from the Environmental Protection Agency (EPA) for all division permits in air, stormwater, wastewater, public water supply, and RCRA, so your facility can file all of your permit applications directly with DEQ.

The Permit Assistance Team will also coordinate meetings between DEQ permit writers and the facility's technical staff. DEQ's permitting staff at every level are keenly aware of the need for a timely turnaround in order to meet construction schedules and other deadlines; and once we receive complete and accurate applications, DEQ has an outstanding track record for getting permits through their queue.

Timelines for each permit type may be found in Section VI of this guide.

## DEQ Contact:

If you have questions, please contact Owen Mills,  
Director, Permit Assistance and Public Outreach Team.



## II. Environmental Permitting Process Summary

OS §27A-2-14 of the Oklahoma Environmental Quality Code established the Oklahoma Uniform Environmental Permitting Act (Act).

It is the intent of the Oklahoma Legislature that the Act provide for uniform permitting provisions regarding notices and public participation opportunities that apply consistently and uniformly to applications for permits and other permit authorizations issued by the Department of Environmental Quality. It requires that DEQ licenses, permits, certificates, approvals, and registrations fit into the Act's application Tier I, II, or III designations.

<https://oksenate.gov/sites/default/files/2019-12/os27A.pdf>



**Tier I** means a basic process of permitting which includes application, notice to the landowner and Department review. For the Tier I process a permit shall be issued or denied by a technical supervisor of the reviewing Division, a local representative of the Department, or the chief engineer of the Department provided such authority has been delegated thereto by the Executive Director;

**Tier II** means a secondary process of permitting which includes:

- a. the Tier I process,
- b. published notice of application filing,
- c. preparation of draft permit or draft denial,
- d. published notice of draft permit or draft denial and opportunity for a formal public meeting, and
- e. public meeting, if any.

Oklahoma Statutes - Title 27A. Environment and Natural Resources Page 287

For the Tier II process, a permit shall be issued or denied by the Director of the reviewing Division or the chief engineer of the Department provided such authority has been delegated thereto by the Executive Director; and

**Tier III** means an expanded process of permitting which includes:

- a. the Tier II process except the notice of filing shall also include an opportunity for a process meeting,
- b. preparation of the Department's response to comments, and
- c. denial of application, or
- d. preparation of a proposed permit, published notice of availability of proposed permit and response to comments and of opportunity for an administrative permit hearing; and administrative permit hearing if any.

For the Tier III process a permit shall be issued or denied by the Executive Director.

OAC 252:4 Rules of Practice and Procedure Appendix C:

<https://oklahoma.gov/content/dam/ok/en/deq/documents/deqmainresources/004.pdf>



# Permitting Process Steps – All Media

Air Quality Permits

Water Quality Permits

Land Protection Permits

Steps	Tier I	Tier II	Tier III
Filing – Applicant files application, pays any required fee, and provides landowner notice. Applicant may meet with DEQ staff prior to this.	Yes	Yes	Yes
Notice of filing – Applicant publishes notice in one newspaper local to site.	No	Yes	Yes
Process meeting – Notice – 30-day opportunity is published with notice of filing. DEQ holds meeting if requested and sufficient interest is shown.	No	No	Yes
Administrative completeness review – DEQ reviews application and asks applicant to supply any missing information.	Yes	Yes	Yes
Technical review – DEQ reviews application for technical compliance and requests applicant to cure any deficiencies.	Yes	Yes	Yes
Draft permit or draft denial – DEQ prepares this after completing review.	No	Yes	Yes
Notice of draft permit, public comment period and public meeting request opportunity – Applicant publishes this in one newspaper local to site (DEQ publishes notice of draft denial).	No <sup>1</sup>	Yes	Yes
Public comment period – 45 days for hazardous waste treatment, storage or disposal draft permits; 30 days for all others.	No <sup>1</sup>	Yes	Yes
Public meeting – Conducted by DEQ if held. The applicant or a representative of the <u>applicant shall be present at the meeting</u> to respond to questions.	No	Yes	Yes
Review of comments – DEQ (written response)	No	Yes	Yes
Proposed permit – DEQ prepares this in response to comments on draft permit.	No	No	Yes
Notice of proposed permit – Applicant publishes, in one newspaper local to site, notice of 20-day opportunity to review permit and request administrative hearing.	No	No	Yes
Administrative permit hearing – Conducted by DEQ if held. Results in final order.	No	No	Yes
Issuance or denial – DEQ’s final decision.	Yes	Yes	Yes

Note for Clean Air Act permits: In order to meet the minimum federal public participation requirements for state air pollution control programs, certain additional steps apply to the AQD permitting process. See OAC 252:4-7-13(g)

1. Tier I Air Permits must be published on the DEQ Website for 30 days. No public meeting or newspaper publication required.

# III. Air Quality Division (AQD)

## Air Permits

Construction and operating permits for air emissions may be required for many operations. Minor Source Tier I, Major Source Tier I and II, and Prevention of Significant Deterioration (PSD) Tier II and III requirements are found in DEQ rules OAC 252:4-7 at <https://tinyurl.com/3ujcwa8n>.

**Permit Exempt** – A facility would not need an air permit if the Potential to Emit (PTE) is below major source levels (100 tons/year of any criteria pollutant – 10 tons/year of any individual federally defined hazardous air pollutant (HAP) – 25 tons/year of all HAPs combined), actual emissions of each criteria pollutant are below 40 tons/year, and the facility is not subject to any emission standard, equipment standard, or work practice standard, under New Source Performance Standard (NSPS) or National Emission Standard for Hazardous Air Pollutants (NESHAP).

**Tier I Minor Source Permit** – A Minor Source Permit is needed if a facility does not qualify as Permit Exempt. Minor Source Individual Permits are processed as Tier I and require a 30-day public review. These permits are typically issued in 4 – 6 months but can be processed in as little as 6 weeks depending upon the need of the facility and the quality of the application.

**Tier II Major Source Permit** – A Major Source Permit is required if the facility does not qualify under the lower categories. Major Source Permits are processed as Tier II permits and require 30-day public review of the draft permit. These are typically issued in 6 – 9 months but timelines vary depending on the company need, facility complexity and application quality.

**Tier III PSD-Major Sources** – PSD-Major Sources are large sources with permitted criteria emissions above 250 tons/year (this level can be 100 tons/year if it is a designated source type as classified by EPA). PSD-Major Source construction permits are processed as Tier III permits and require 30-day public review of the draft and 20-day public review of the proposed permit. These permits are typically issued in 9 – 12 months.



**Permit Modification** – These facilities often do modifications to their facilities. These modifications are processed as either Tier I or Tier II based on the nature of the project. Tier I modifications are typically issued in 3 – 6 months. Tier II modifications are typically issued in 6 – 9 months. Depending on the type of application submitted, certain construction activities are allowed prior to issuance of the construction permit.

- **Major-PSD New Source Review (NSR) construction projects** – AQD follows EPA guidance on what construction activities are allowed prior to issuance of the construction permit.
- **Minor NSR projects** – Facilities may begin construction upon submittal of an administratively complete permit application and prior to issuance of the construction permit. An applicant may begin construction up to, but not including, making any emissions unit operational. In initiating these activities prior to permit issuance, the applicant assumes the risk of losing any investment it makes toward initiating construction. DEQ retains the authority to deny the permit application without consideration of and regardless of any investment the applicant has made prior to permit issuance. The regulations address this issue in OAC 252:100-7-2(b)(5) and OAC 252:100-8-4(a)(1)(D). Please contact the AQD permitting section at 405-702-4188 for further guidance.

# Transparency in Permitting

DEQ is transitioning to a new web application titled “Permits for Public Review,” that presents the steps in the process and gives public access to view and download pertinent documents of the permitting process from application to finalization

Step 1
Step 2
Step 3
Step 4
Step 5
6A
6B
Step 7
Step 8

**PLANT | 2018-000000 -TVR3 (AQD)**  
Tier II - Title V Operating Permit

**Step: Technical Review**  
**Status: Under DEQ Review**

Application Receipt Date: 3/2/2018  
Calendar Days: 2937  
DEQ Review Days: 106

Process Step Descriptions

#	Description
1	Filing – Applicant files application, pays any required fee, and provides landowner notice. Applicant may meet with DEQ staff prior to this.
2	Notice of filing – Applicant publishes notice in one newspaper local to site.
3	Administrative completeness review – DEQ reviews application and asks applicant to supply any missing information.
4	Technical review – DEQ reviews application for technical compliance and requests applicant to cure any deficiencies.
5	Draft permit or draft denial – DEQ prepares this after completing review.
6A	Notice of draft permit, public comment period and public meeting request opportunity – Applicant publishes this in one newspaper local to site (DEQ publishes notice of draft denial). Public comment period – 45 days for hazardous waste draft permits; 30 days for all others.
6B	Public meeting – Conducted by DEQ if held. The applicant or a representative of the applicant shall be present at the meeting to respond to questions.
7	Review of comments – DEQ (written response)
8	Issuance or denial – DEQ’s final decision.

Related Documents

Document Name	Date
<a href="#">Application Additional Submittal</a>	Oct 12, 2023
<a href="#">Application Additional Submittal</a>	Nov 25, 2025
<a href="#">Application Additional Submittal</a>	Nov 04, 2019
<a href="#">Notice of Filing</a>	Mar 21, 2018
<a href="#">Permit Application</a>	Mar 02, 2018
<a href="#">Administratively Complete Letter</a>	Apr 27, 2018



# IV. Water Quality Division (WQD)

## A. Stormwater Permits

**Stormwater permit authorizations are typically issued within 14-30 days.**

<https://oklahoma.gov/deq/permits/water-permits/stormwater-permitting.html>

**1. Construction** – A construction stormwater permit will be required if the project will disturb one (1) or more acres. The Oklahoma Pollution Discharge Elimination System (OPDES) requires construction site owners/operators to obtain coverage under the OPDES Construction General Permit OKR10 to discharge stormwater from their construction sites. As part of the application, the owner and/or operator must develop and implement a Stormwater Pollution Prevention Plan (SWP3) to minimize pollutants and reduce stormwater runoff. The applicant may also need additional permit coverage from the city/county government for the construction site. The applicant will need to file a Notice of Intent (NOI).

<https://tinyurl.com/2c8zdyeh>



**2. Industrial** – Facilities wishing to discharge stormwater associated with industrial activities may elect to obtain coverage under either the stormwater multi-sector general permit OKR05 or an individual OPDES discharge permit. As part of the application process, the owner or operator must develop a stormwater pollution prevention plan (SWP3) that explains how it will control and reduce pollutants in the stormwater runoff and submit an NOI or permit application to DEQ. The applicant may also need additional permit coverage from the city/county government for the construction site.

<https://tinyurl.com/34pwmyaw>



Notices of Intent (NOIs) may be submitted online (preferred), via email or through the mail. Learn more about Stormwater Permitting here:

<https://oklahoma.gov/deq/permits/water-permits/stormwater-permitting.html>



## B. Wastewater Permits

**1. Industrial User Permit** – If the facility's wastewater system is to be connected to a Publicly Owned Treatment Works (POTW), an Industrial User Permit will be required if the facility will contribute a significant volume of wastewater flow (>25,000 gallons per day or >5 percent of the total loading to the POTW) or if the wastewater will contain pollutants likely to pass through or interfere with treatment processes at the POTW. If the POTW operates an approved pretreatment program it will issue the industrial user permit. Otherwise DEQ will issue the permit. In either case, a permit can typically be issued within six months. The application form and instructions for a DEQ Industrial User Permit in a non-pretreatment municipality can be found on the DEQ website here:

<https://tinyurl.com/yxjbt4s8>



**2. Municipal Wastewater Discharge Permit – Tier II and Tier III** – If a facility is in need of a new direct discharge permit, a wasteload allocation (WLA) study and public notice will be required, as well as a public meeting, if requested. The WLA will also prompt an update to the state’s Water Quality Management Plan (WQMP) including technical review by EPA and a second (often concurrent) public process for the WQMP. This update must occur prior to issuance of the discharge permit. The entire process commonly takes a year or more. Municipal Wastewater Discharge Permit rules begin with Subchapter 3 of OAC 252:606 (OPDES Standards) and may be found at:



<https://oklahoma.gov/content/dam/ok/en/deq/documents/deqmainresources/606.pdf>

**3. Wastewater System (Surface Impoundment, Tank System, or Land Application) Permit** – If the facility proposes to store water in an impoundment or subsurface tank or land apply sludge or wastewater, a permit to construct and operate the wastewater system will be required. The permitting process can take up to 6 months, depending on the complexity of the wastewater system. and the completeness of the application. Industrial wastewater system rules begin with Subchapter 3 of OAC 252:616 and may be found at:



<https://oklahoma.gov/content/dam/ok/en/deq/documents/deqmainresources/616.pdf>

**4. Water Reuse** – If the facility proposes to purchase reclaimed water from a POTW, the facility must enter into a User/Supplier agreement with the POTW, and the POTW must seek to modify their DEQ permit to supply reclaimed water to the User. The POTW must be permitted to supply reclaimed water of a category appropriate for the proposed use. The relevant rules for the operation and maintenance of water reuse systems begin with Subchapter 1 of OAC 252:627. The relevant rules for Land application of reclaimed water begin in Subchapter 25 of OAC 252:656:



<https://oklahoma.gov/content/dam/ok/en/deq/documents/deqmainresources/627.pdf>  
and



<https://oklahoma.gov/content/dam/ok/en/deq/documents/deqmainresources/656.pdf>

## C. Public Water Supply Permits

In many cases, an industrial facility will become a customer of an existing public water supply system rather than developing its own source of drinking water, so no permit would be required.

If a facility develops its own source of drinking water, a DEQ construction permit will be required. A water right will likely be required as well. Contact Permitting at the Oklahoma Water Resources Board, 405-530-8800.

## D. Oklahoma DEQ Wasteload Allocations (WLA) Process for All New Discharges

1. Official letter from the Designated Management Agency (DMA) requesting to discharge
2. Discharger submits an Alternatives Report- A report that explains why discharging is the most feasible option (Oklahoma CPP page 158).
3. The discharger will submit a workplan providing details of how data will be collected and how that data will be used in a model(s) to develop a WLA.
4. Sampling may begin after the workplan is approved by DEQ.
5. Development of a water quality model to determine the impact of oxygen demanding substances on the instream D.O. concentration.
6. After the model and WLA report are submitted to DEQ, DEQ has 30 days to review.
7. If there are no issues with the model and/or the report, the model files and report will be transmitted to EPA for technical approval. EPA Region 6 has 30 days to review the information.
8. After EPA technical approval is granted and any EPA comments are addressed, a public notice of 208 Plan modification will be published.
9. The public comment period is open for 45 days. If there is a significant interest based on comments received, then a public meeting will be scheduled.
10. If a public meeting is warranted, notices will be sent out informing the public of the location and time of the meeting.
11. DEQ will address all public comments received during public notice period and submit the final document to EPA for approval. EPA will have 30 days for final review.
12. Subsequent to EPA approval, DEQ will update the 208 Plan for the facility with the new WLA.
13. The approved WLA will be incorporated into the facility's discharge permit.

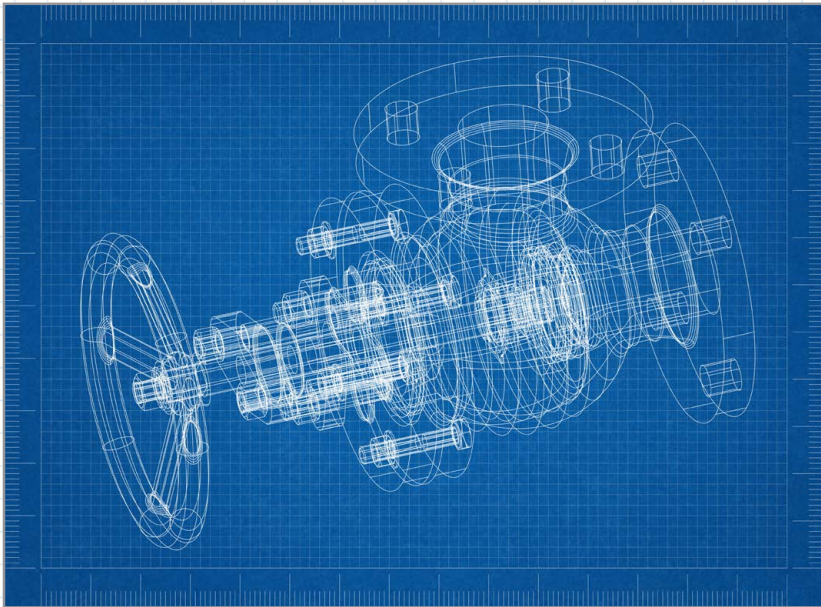

# V. Land Protection Division (LPD)

## A. Hazardous Waste

**1. Resource Conservation and Recovery Act (RCRA) Permits** – A RCRA permit is required for a facility that does one or more of the following:

- stores hazardous wastes for greater than 90 days;
- treats hazardous waste; and/or
- disposes of hazardous waste on-site.

**2. Generator Requirements** – If a facility generates hazardous waste, it must follow RCRA rules for its generator size as provided in the federal rules, which Oklahoma has adopted by reference. These rules may be found at:

<https://oklahoma.gov/content/dam/ok/en/deq/documents/deqmainresources/205.pdf>



## B. Solid Waste

**1. Solid Waste Permits** – The following types of facilities are considered solid waste disposal facilities and will require a permit from DEQ prior to construction and/or operation.

- Land disposal facilities** – a landfill, or any other discrete area of land or land excavation, where solid waste is placed for treatment, processing, and/or disposal, with some exceptions.
- Solid waste processing facilities** – including: transfer stations; solid waste incinerators receiving waste from off-site sources; regulated medical waste processing facilities receiving waste from off-site sources, and that are not shared service facilities; waste tire facilities; composting facilities, except yard waste composting facilities; permanently established household hazardous waste collection facilities; and any other type of facility that processes solid waste.
- Solid waste storage** – facilities used for the storage of solid waste for longer than 10 days.
- Used tire storage** – facilities used for the storage of more than 50 waste tires, except as authorized by 27A O.S. § 2-11-401.7.



**2. Non-Hazardous Industrial Waste (NHIW) Disposal** – If a facility disposes more than 10 cubic yards per month of non-hazardous industrial waste NHIW, as defined in 27A O.S. § 2-10-103 (definition 16), it will need to submit a non-hazardous industrial waste certification to DEQ before sending the waste to an Oklahoma landfill for disposal.



<https://www.oscn.net/applications/oscn/DeliverDocument.asp?CiteID=79100>

The NHIW certification form can be found at:

<https://tinyurl.com/yc4e25yb>



## C. SARA Title III (Superfund)

Facilities that store chemicals requiring a Safety Data Sheet (SDS) or perform manufacturing that uses hazardous chemicals may have reporting requirements under the Superfund Amendments and Reauthorization Act (SARA) Title III.

**1. Tier 2 Reporting** – Facilities storing 500 lbs. of a listed Extremely Hazardous Substance (list can be found on DEQ website or on SDS) or storing any other chemical requiring an SDS in amounts over 10,000 lbs. will be required to report that storage on a Tier 2 form. Due date is March 1st annually. Oklahoma requires on-line reporting; instructions can be found on the DEQ website.



<https://tinyurl.com/y3h2m84m>

**2. Toxic Release Inventory** – Facilities engaged in manufacturing, having more than 10 full time employees, and using listed chemicals in threshold amounts, all of which can be found on the EPA TRI website, may be required to report a Form R under the Toxic Release Inventory (TRI). Those reports are due annually on July 1st and must be submitted electronically over the EPA website. Reports are then transmitted to Oklahoma. All instructions and reporting material may be found on the EPA website.



<https://www.epa.gov/toxics-release-inventory-tri-program/reporting-tri-facilities>

## D. Radiation Management

This section is responsible for regulation of radioactive materials, industrial/analytical x-ray machines and particle accelerators, and medical therapeutic x-ray machines and particle accelerators. (It does not regulate medical diagnostic X-Ray machines.) Additional information can be found at:



<https://oklahoma.gov/deq/divisions/land-protection/radiation.html>

## E. Underground Injection Control

This section is responsible for regulation of injection wells not associated with oil and gas activity, which are regulated by the Oklahoma Corporation Commission. Additional information can be found at:



<https://oklahoma.gov/deq/divisions/land-protection/underground-injection-control.html>

## VI. Permit Process Timelines

<b>Tier I</b>	<b>Air Quality Division Permits . . . . .</b>	<b>16</b>
<b>Tier I</b>	<b>Industrial Wastewater Permits . . . . .</b>	<b>17</b>
<b>Tier II</b>	<b>Air Quality Division Permits . . . . .</b>	<b>18</b>
<b>Tier II</b>	<b>Industrial Wastewater Permits . . . . .</b>	<b>19</b>
<b>Tier II</b>	<b>Land Protection Division Permits . . . . .</b>	<b>20</b>
<b>Tier III</b>	<b>Air Quality Division Permits . . . . .</b>	<b>21</b>
<b>Tier III</b>	<b>Industrial Wastewater Permits . . . . .</b>	<b>22</b>
<b>Tier III</b>	<b>Land Protection Division Permits . . . . .</b>	<b>23</b>
	<b>Wasteload Allocation (WLA) Process . . . . .</b>	<b>24</b>

Air Quality Permits

Water Quality Permits

Land Protection Permits



# Tier I Air Quality Division Permits\*

## Minor Source

Month	1	2	3	4	5	6
Administrative Review						
Technical Review						
Draft Permit 30-Day Public Review						
Response to Comments and Issuance						

\*Does not represent potential extensive public comment time frame.

Note: Blue time line represents application completeness and effective communication, gray designates schedule flexibility for increased permit complexity.

# Tier I Industrial Wastewater Permits

## General and State Permitting Process

DEQ has several general permits to assist certain industries with obtaining their authorizations more quickly and without public notice. Authorizations under a general permit can usually be processed in 7 – 45 days if the applications are complete. The application forms are available on the DEQ website:

<https://oklahoma.gov/deq/permits/water-permits/industrial-permitting.html>



DEQ also has state permits that are available to total retention facilities. These go through public notice the first time they are issued or the first time a land application site is permitted but not upon renewal. The application forms are available on the DEQ website. State permits can usually be processed in 2 – 4 months if the applications are complete.



# Tier II Air Quality Division Permits\*

## Non-PSD Major Source

Month	1	2	3	4	5	6	7	8	9
Notice of Filing	30 Day								
Administrative Review									
Technical Review									
Draft Permit (Public Review)					30 Day			30 Day	
Response to Comments and Public Meeting									
Issuance							60 to 90 Days		

\*Does not represent potential extensive public comment time frame.

Note: Blue time line represents application completeness and effective communication, gray designates schedule flexibility for increased permit complexity.

# Tier II Industrial Wastewater Permits

## Facility and EPA Review Concurrent<sup>1</sup>

Month	1	2	3	4	5	6	7	8	9	10	11	12
Public Notice of Application <sup>2</sup>	█											
Administrative Review <sup>2</sup>	█	█										
Technical Review <sup>3</sup>			█	█	█	█	█	█	█			
Draft Permit Reviewed by EPA and Facility										█		
Public Notice of Draft Permit											█	
Issuance												█

**1** Presumes no comments received from EPA, the facility or the public.

**2** WLA process may be performed concurrently.

**3** If WLA is required, Technical Review cannot begin until WLA is approved.



# Tier II Land Protection Division Permits

## Facility and EPA Review Concurrent<sup>1,5</sup>

Month	1	2	3	4	5	6	7	8
Public Notice of Application	█							
Administrative Review	█	█						
Technical Review	█	█	█	█				
Draft Permit Reviewed by EPA and Facility <sup>2</sup>					█			
Public Notice of Draft Permit <sup>3</sup>						█		
Public Notice of Public Meeting, if requested <sup>4</sup>							█	
Issuance								█

1 Timelines may vary depending on company need, facility complexity, application quality and comments received.

2 Solid Waste permits do not require EPA review.

3 Public Notice for a draft RCRA permit is 45 days. All other LPD draft permits are 30 days.

4 Public meetings require a 30-day notice. The applicant may choose to voluntarily conduct the public meeting with the draft permit to ensure the timeline is not extended an additional 30 days for the notice. If comments are received, a response to comments must be prepared, which can take 60 to 90 days.

5 For RCRA permits, additional federal requirements apply.

# Tier III Air Quality Division Permits\*

## PSD Major Source

Month	1	2	3	4	5	6	7	8	9	10	11	12
Notice of Filing	30 Day											
Administrative Review												
Technical Review												
Draft Permit (Public Review)							30 Day			30 Day		
Response to Comments (30 Day) and Proposed Permit Public Review (20 Day)								50 Day			50 Day	
Issuance												

\*Does not represent potential extensive public comment time frame.

Note: Blue time line represents application completeness and effective communication, gray designates schedule flexibility for increased permit complexity.



# Tier III Industrial Wastewater Permits

## Facility and EPA Review Concurrent<sup>1</sup>

Month	1	2	3	4	5	6	7	8	9	10	11
Public Notice of Application <sup>2</sup>	█										
Administrative Review <sup>2</sup>	█	█									
Technical Review <sup>3</sup>			█	█	█	█	█	█			
Draft Permit Reviewed by EPA and Facility									█		
Public Notice of Draft Permit										█	
Issuance											█

**1 Presumes no comments received from EPA, the facility or the public.**

**2 WLA process may be performed concurrently.**

**3 If WLA is required, Technical Review cannot begin until WLA is approved.**

# Tier III Land Protection Division Permits

## Facility and EPA Review Concurrent<sup>1,7</sup>

Month	1	2	3	4	5	6	7	8	9
Public Notice of Filing Application	█								
Public Notice of Process Meeting, if requested <sup>2</sup>	█								
Administrative Review	█	█							
Technical Review	█	█	█	█	█				
Draft Permit Reviewed by EPA and Facility <sup>3</sup>						█			
Public Notice of Draft Permit <sup>4</sup>							█		
Public Notice of Public Meeting, if requested <sup>5</sup>								█	
Public Notice of Proposed Permit <sup>6</sup>									█
Issuance									█

**1** Timelines may vary depending on company need, facility complexity, application quality and comments received.

**2** 30-day opportunity to request a process meeting is published with the notice of filing. Public meetings require a 30-day notice. The applicant may choose to voluntarily conduct the public meeting with the draft permit to ensure the timeline is not extended an additional 30 days for the notice. If comments are received, a response to comments must be prepared.

**3** Solid Waste permits do not require EPA review.

**4** Public Notice for a draft RCRA permit is 45 days. All other LPD draft permits are 30 days.

**5** Public meetings require a 30-day notice. The applicant may choose to voluntarily conduct the public meeting with the draft permit to ensure the timeline is not extended an additional 30 days for the notice. If comments are received, a response to comments must be prepared.

**6** Public notice of proposed permit is 20 days. The public has the opportunity to request an administrative hearing. Final Issuance timeline presumes no administrative hearing is requested.

**7** For RCRA permits, additional federal requirements apply.

# Wasteload Allocation (WLA) Process

## For New Discharges

Water Quality Permits

Month	1	Undetermined <sup>1</sup>	2	3	4	5	6	7	8
DEQ Reviews WLA Workplan									
Facility Performs Sampling & Analysis, Prepares WLA Report		Not Under DEQ Control							
DEQ Draft of WLA Report									
EPA Review & Technical Acceptance of WLA Report									
Public Notice Process <sup>2</sup>									
Response to Public Comments									
EPA Reviews Draft Final WLA Report									
Time to Respond to Comments on Workplan, WLA Report and Modeling									

<sup>1</sup> Sampling, analysis, modeling, and report preparation could result in lengthening the WLA process by an additional 4-10 months. The additional time will vary based on seasonal monitoring requirements, number of samples required, and model complexity.

<sup>2</sup> If, as a result of public notice, there is significant interest, a public hearing will be scheduled. WLA Process will not proceed until public hearing is completed.

## VII. Permitting Fees

### Air Permit Application Fees for Minor Facilities

**Minor Facility Permit Application Fees:** A permit application or a request for an applicability determination will be assessed a one-time fee that must accompany the application or request. Applications received without appropriate fees are incomplete. Fees must be paid by check or money order made payable to the Department of Environmental Quality in accordance with the following fee schedule:

**Note: Fees in this guide are for your convenience and not authoritative. All values are subject to change.**

#### Applicability Determination

\$500, to be credited against the construction or operating permit application fee, if a permit required. If no permit is required, the fee will be retained to cover the cost of making the determination.

#### Construction Permit Application Fees

Permit by Rule Registration	\$250
General Permit Authorization or NOI (Notice of Intent)	\$500
Individual Permit (Initial Construction or for Added Emissions)	\$2,000
Amendments of Individual Permits Which Do Not Increase Emissions	\$500
Extension of Time and Transfer of Ownership	No Fee

#### Operating Permit Application Fees

Permit by Rule Registration	\$100
General Permit Authorization	\$500
Individual permit	\$750
Modification of Individual Permit	\$750
Relocation	\$250

## Air Permit Application Fees for Part 70 Sources and Major New Source Review Sources

**Permit Application Fees:** A permit application or a request for an applicability determination will be assessed a one-time fee, which must accompany the application or request. Applications received without appropriate fees are administratively incomplete. Fees must be paid by check or money order made payable to the Department of Environmental Quality in accordance with the following fee schedule:

**Note: Fees in this guide are for you convenience and not authoritative. All values are subject to change.**

Applicability Determination	
\$500, to be credited against the construction or operating permit application fee, if a permit is required. If no permit is required, the fee will be retained to cover the cost of making the determination.	
Construction Permit Application	
New Part 70 Source	\$7,500
Modification of a Part 70 Source	\$5,000
Authorization Under a General Permit	\$900
Operating Permit Application	
Initial Part 70 Permit	\$7,500
Authorization Under a General Permit	\$900
Renewal Part 70 permit	\$7,500
Significant Modification of Part 70 Permit	\$6,000
Minor Modification of Part 70 Permit	\$3,000
Part 70 Temporary Source Relocation	\$500

## Water Permit Application Fees for Minor Water Systems and Stormwater

**Note: Fees in this guide are for you convenience and not authoritative. All values are subject to change.**

Construction Stormwater Authorization r (OKR10) :	\$447.71 (\$100 application fee + \$347.71 annual fee)
Industrial Stormwater Authorization (OKR05):	\$447.71 (\$100 application fee + \$347.71 annual fee)
Minor Public Water Supply System (<15 connections or <25 population) new application:	\$279.10
Minor Water System annual fee (invoiced July each year):	\$244.25

The Minor Water fees change (increases) July 1 each year with the Consumer Price Index (CPI).

## Permit Application Fees for Industrial Wastewater

**Note: Fees in this guide are for you convenience and not authoritative. All values are subject to change.**

OPDES Permit Application Fee		FY2025	FY2026
	FY Consumer Price Index Percent increase	1.041	1.029
Application Type	Billing Basis		
Application Fee Class I Significant Risk	OAC 252:616-3-3(a)(1) + CPI after FY2013	\$405.69	\$417.46
Application Fee Class II Moderate Risk	OAC 252:616-3-3(a)(2) + CPI after FY2013	\$270.45	\$278.29
Application Fee Class III and General Permit No Substantial Risk	OAC 252:616-3-3(a)(3) + CPI after FY2013 OAC 252:606-3-4(d)(1) + CPI after FY2013	\$135.23	\$139.15
Application Fee Class V Other IWW	OAC 252:616-3-3(a)(4) + CPI after FY2013	\$429.93	\$442.40
Individual Discharge Major Application Fee	OAC 252:606-3-4(b)(1)(A,B) + CPI after FY2013	\$676.15	\$695.76
Individual Discharge Minor Application Fee	OAC 252:606-3-4(b)(1)(A,B) + CPI after FY2013	\$676.15	\$695.76
Individual Industrial User Permit Application Fee	OAC 252:606-3-4(c)(1)(A,B) + CPI after FY2013	\$676.15	\$695.76

**Note: Annual fees also apply for Industrial Tank Systems and Surface Impoundments by wastewater class.**

# Hazardous Waste and Underground Injection Control Fees

**Note: Fees in this guide are for you convenience and not authoritative. All values are subject to change.**

Fees for Hazardous Waste Generators	
Large Quantity Generator Monitoring and Inspection	\$300.00/year
Small Quantity Generator	\$25.00/year
Fees for Treatment, Storage, and Disposal Facilities	
Permit Application Fees	
Base Fee	\$3,000.00
Tanks and Containers	Base Fee + \$2,000
Waste Piles	Base Fee + \$2,500
Miscellaneous Thermal Unit	Base Fee + \$2,000
Incinerator, Boiler and Industrial Furnace, Thermal Treatment	Base Fee + \$12,000
Land Treatment Unit	Base Fee + \$6,000
Landfill, Surface Impoundment	Base Fee + \$20,000
Research	Base Fee + \$2,000
Recycling	Base Fee + \$2,000
Injection Well (Hazardous Waste)	Base Fee + \$15,000
Injection Well (Non-Hazardous Waste)	Application Fee: \$2,000 Renewal Fee: \$500

## Waste Management Fees

### Treatment, Storage, or Land Disposal

On-Site	\$9.50/ton \$20,000/year minimum
Off-Site	\$9.50/ton \$50,000/year minimum for treatment or land disposal \$20,000/year minimum for storage
On-Site Generation and Treatment of Hazardous Waste to Meet BDAT, and On-Site Disposal	\$4.50/ton For Land Disposal Until \$22,000 Has Been Paid, Then \$9.00/ton \$0.015/gallon for Underground Injection Until \$22,000 Has Been Paid, Then \$0.03/gallon

### Recycling

On-Site	No Fee
Off-Site	\$4.00/ton \$20,000/year minimum except no fee for facilities recycling less than 10 tons per month

### Underground Injection

On-Site	\$0.03/gallon for hazardous waste. Maximum fee \$50,000/year \$0.0002/gallon for non-hazardous waste. Minimum fee \$10,000/year. Maximum fee \$50,000/year
Off-Site	\$0.03/gallon for hazardous waste \$0.0002/gallon for non-hazardous waste. Minimum fee \$10,000/year. Maximum fee \$50,000/year

### Research and Design Testing

On-Site	No Fee
Off-Site	\$9.00/ton for treatment, storage, or disposal \$4.00/ton for recycling Minimum \$10,000/year

### Fees for Delisting of Hazardous Waste

Base Application Fee	\$20,000 for first petition \$15,000 for or subsequent petitions submitted at the same time
Monitoring Fee	\$1,200/year for each delisted waste

## Solid Waste Disposal Fees

**Note: Fees in this guide are for your convenience and not authoritative. All values are subject to change.**

Facility Type	Fee*
Commercial Landfill	\$1.25/ton
Commercial Incinerator	\$1.25/ton
Commercial Composting Facility	\$1.25/ton
Roofing Material Recycling Facility	\$1.25/ton

\*Fee is charged by the facility to users of the facility, and remitted to the DEQ. For new facilities, fee is \$1.50/ton, with a provision that the facility will retain \$0.25/ton for capital improvements (such as for purchase/installation of scales) until a total of \$40,000 has been recouped, then the fee will drop to \$1.25/ton.





Tulsa



# OKLAHOMA Environmental Quality

