

# Carpentry Skills Workbook

Student Edition  
[www.okcimc.com](http://www.okcimc.com)  
800-654-4502

**CIMC**

12-034567890

TI3645

# CARPENTRY SKILLS WORKBOOK

This free curriculum resource provided by  
the Resource Center for CareerTech Advancement  
Oklahoma Department of Career and Technology Education  
<https://www.okcareertech.org/educators/resource-center>



Developed by the  
Curriculum and Instructional Materials Center  
for the Trade and Industrial Education Division  
Oklahoma Department of Career and Technology Education

Copyright 2012

Project Manager: Craig Maile  
Graphic Design: Kathy Wood

Oklahoma Department of Career and Technology Education  
Curriculum and Instructional Materials Center

All rights reserved.

Permission granted to download and print this publication for non-commercial use in a classroom or training setting.

Printed in the United States of America by the  
Oklahoma Department of Career and Technology Education  
Stillwater, Oklahoma 74074-4364

This publication, or parts thereof, may not be reproduced in any form by photographic, electrostatic, mechanical, or any other methods for any use including information storage and retrieval, without written permission from the publisher.

Web site addresses were accurate and all content on referenced web sites was appropriate during development and production of this product. However, web sites sometimes change; the CIMC takes no responsibility for a site's content. The inclusion of a web site does not constitute an endorsement of that site's other pages, products, or owners. You are encouraged to verify all web sites prior to use.

The Oklahoma Department of Career and Technology Education does not discriminate on the basis of race, creed, color, national origin, sex, age, veteran status, or qualified handicap.

# TABLE OF CONTENTS

## RESIDENTIAL CARPENTRY

<b>Residential Door Installation</b> .....	9
Job Sheet 1 .....	11
<b>INSTALL A METAL THRESHOLD ON A CONCRETE FLOOR</b>	
Job Sheet 2 .....	15
<b>INSTALL AN ENTRY DOOR FRAME, CASING, DOOR, AND LOCK</b>	
Job Sheet 3 .....	23
<b>INSTALL AN EXTERIOR PREHUNG DOOR UNIT</b>	
Job Sheet 4 .....	27
<b>INSTALL WEATHERSTRIPPING</b>	
Job Sheet 5 .....	31
<b>INSTALL DOOR FRAME AND INSIDE JAMBS FOR AN OVERHEAD DOOR</b>	
Job Sheet 6 .....	37
<b>INSTALL A SPLIT-JAMB PREHUNG DOOR UNIT</b>	
Job Sheet 7 .....	41
<b>INSTALL A SOLID-JAMB DOOR UNIT</b>	
Job Sheet 8 .....	45
<b>INSTALL INTERIOR DOOR FRAME, DOOR, LOCK, AND TRIM</b>	
Job Sheet 9 .....	55
<b>INSTALL A BIFOLD DOOR UNIT</b>	
Job Sheet 10 .....	59
<b>INSTALL A POCKET DOOR UNIT</b>	
<b>Residential Roof Framing</b> .....	63
Job Sheet 1 .....	65
<b>LAY OUT RAFTER LOCATIONS ON THE TOP PLATE AND RIDGEBOARD ON 2' CENTERS</b>	
Job Sheet 2 .....	69
<b>LAY OUT, CUT, AND INSTALL CEILING JOISTS AND ERECT RAFTERS FOR GABLE ROOFS</b>	
Job Sheet 3 .....	79
<b>FRAME A GABLE END WITH A VENT OPENING</b>	

Job Sheet 4 .....	85
<b>LAY OUT AND CUT CEILING JOISTS AND RAFTERS FOR HIP ROOFS</b>	
Job Sheet 5 .....	97
<b>ERECT CEILING JOISTS AND RAFTERS FOR HIP ROOFS</b>	
Job Sheet 6 .....	101
<b>LAY OUT, CUT, AND ERECT RAFTERS FOR AN INTERSECTING HIP ROOF WITH VALLEY</b>	
Job Sheet 7 .....	115
<b>FRAME AN OPENING IN A ROOF</b>	
Job Sheet 8 .....	119
<b>APPLY ROOF SHEATHING</b>	
Table 1 .....	123
Table 2 .....	124
<b>Wall and Ceiling Framing .....</b>	<b>125</b>
Job Sheet 1 .....	127
<b>LAY OUT WALL PARTITION LOCATIONS ON FLOOR</b>	
Job Sheet 2 .....	133
<b>CUT STUDS, TRIMMERS, CRIPPLES, AND HEADERS TO LENGTH</b>	
Job Sheet 3 .....	139
<b>ASSEMBLE CORNERS, TS, AND HEADERS</b>	
Job Sheet 4 .....	145
<b>CONSTRUCT WALL SECTIONS</b>	
Job Sheet 5 .....	155
<b>LAY OUT AND INSTALL CEILING JOISTS</b>	
Job Sheet 6 .....	161
<b>INSTALL FIBERBOARD OR INSULATION-PANEL, DRYWALL, AND PLYWOOD SHEATHING</b>	
Job Sheet 7 .....	167
<b>INSTALL SHEATHING AND PLYWOOD SIDING</b>	
<b>Stair Framing .....</b>	<b>173</b>
Job Sheet .....	175
<b>CONSTRUCT A STAIR</b>	
<b>Cornice and Gable Ends .....</b>	<b>183</b>
Job Sheet 1 .....	185
<b>BUILD A HORIZONTAL BOX CORNICE</b>	
Job Sheet 2 .....	197
<b>APPLY SIDING TO GABLE END</b>	



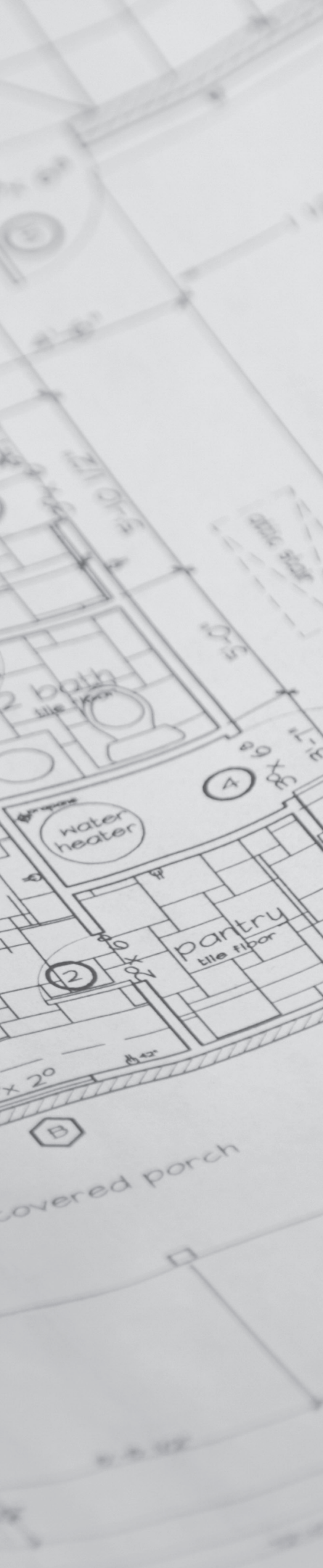

<b>Exterior Walls and Trim</b> .....	203
Job Sheet 1 .....	205
<b>INSTALL FIBERBOARD OR INSULATION-PANEL, GYPSUM-BOARD, AND PLYWOOD SHEATHING</b>	
Job Sheet 2 .....	211
<b>INSTALL BEVEL SIDING</b>	
Job Sheet 3 .....	219
<b>INSTALL SHEATHING AND PLYWOOD SIDING</b>	
Job Sheet 4 .....	227
<b>INSTALL VINYL SIDING</b>	
<b>Cabinets Shelves, and Built-Ins</b> .....	241
Job Sheet 1 .....	243
<b>INSTALL A FACTORY-BUILT CABINET</b>	
Job Sheet 2 .....	251
<b>INSTALL SHELVES IN A CLOSET</b>	
<b>Floor Finishing</b> .....	257
Job Sheet 1 .....	259
<b>INSTALL UNDERLAYMENT</b>	
Job Sheet 2 .....	263
<b>INSTALL RESILIENT TILE</b>	
Job Sheet 3 .....	271
<b>INSTALL TONGUE-AND-GROOVE HARDWOOD STRIP FLOORING</b>	
Job Sheet 4 .....	277
<b>INSTALL BLOCK FLOORING</b>	
<b>Roof Finishes</b> .....	283
Job Sheet 1 .....	285
<b>USE A ROOFER'S HATCHET PROPERLY</b>	
Job Sheet 2 .....	289
<b>USE A PNEUMATIC FASTENER</b>	
Job Sheet 3 .....	293
<b>APPLY ASPHALT SHINGLES WITH A 5" EXPOSURE</b>	
Job Sheet 4 .....	301
<b>APPLY WOOD SHINGLES WITH A 5" EXPOSURE OVER SPACED SHEATHING</b>	

# COMMERCIAL CARPENTRY

<b>Column Forms</b> .....	307
Job Sheet 1 .....	309
<b>CONSTRUCT AND STRIP FORMS FOR A SQUARE COLUMN</b>	
Job Sheet 2 .....	315
<b>SET AND STRIP A ROUND COLUMN</b>	
<b>Beam Forms</b> .....	321
Job Sheet 1 .....	323
<b>CONSTRUCT AND STRIP A SPANDREL BEAM FORM</b>	
Job Sheet 2 .....	333
<b>CONSTRUCT AND STRIP AN INTERIOR BEAM FORM</b>	
Job Sheet 3 .....	339
<b>CONSTRUCT AND STRIP A PLATE GIRDER BEAM FORM</b>	
<b>Above-Grade Slab Systems</b> .....	345
Job Sheet 1 .....	347
<b>CONSTRUCT AND STRIP FORMS FOR A ONE-WAY JOIST SYSTEM</b>	
Job Sheet 2 .....	355
<b>CONSTRUCT AND STRIP FORMS FOR A TWO-WAY JOIST SYSTEM</b>	
Job Sheet 3 .....	367
<b>CONSTRUCT, SET, AND STRIP A FLYING SLAB FORM</b>	
Job Sheet 4 .....	373
<b>SET SCREEDS ON A DECK FOR A FLAT SLAB</b>	
<b>Bridge Deck Forms</b> .....	377
Job Sheet .....	379
<b>CONSTRUCT AND STRIP FORMS FOR A BRIDGE DECK</b>	
<b>Fireproof Encasement Forms</b> .....	385
Job Sheet .....	387
<b>CONSTRUCT AND STRIP FIREPROOF ENCASEMENT FORMS FOR BEAMS</b>	



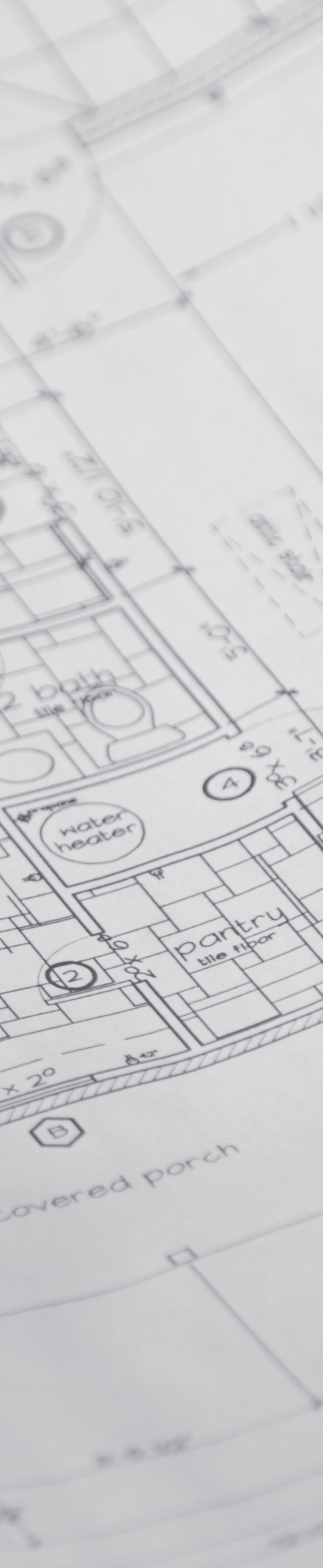

<b>Commercial Door Installation</b> .....	395
Job Sheet 1 .....	397
<b>INSTALL A METAL THRESHOLD ON A CONCRETE FLOOR</b>	
Job Sheet 2 .....	401
<b>INSTALL A METAL KNOCKDOWN-TYPE DOOR FRAME</b>	
Job Sheet 3 .....	407
<b>INSTALL AN ENTRY DOOR FRAME, CASING, DOOR, AND LOCK</b>	
Job Sheet 4 .....	417
<b>INSTALL AN EXTERIOR PREHUNG DOOR UNIT</b>	
Job Sheet 5 .....	423
<b>INSTALL WEATHERSTRIPPING</b>	
Job Sheet 6 .....	427
<b>INSTALL DOOR FRAME AND INSIDE JAMBS FOR AN OVERHEAD DOOR</b>	
Job Sheet 7 .....	433
<b>INSTALL INTERIOR DOOR FRAME, DOOR, LOCK, AND TRIM</b>	
 PROFILE OF TRAINING MASTERY .....	 443





# **RESIDENTIAL DOOR INSTALLATION**

**CARPENTRY SERIES**



# RESIDENTIAL DOOR INSTALLATION CARPENTRY SERIES JOB SHEET

# 1

Student Name: \_\_\_\_\_ Score: \_\_\_\_\_

## INSTALL A METAL THRESHOLD ON A CONCRETE FLOOR.

### BASIC SKILLS



### INTRODUCTION

Installing a metal threshold on a concrete floor requires attention to the door opening and threshold measurements. Metal thresholds are manufactured in various heights and widths with door openings ranging from standard to customized sizes. The threshold is usually positioned so that the closed door is approximately centered over the door opening. Metal thresholds may have a vinyl insert used to adjust the height of the threshold and provide a seal for the door. Always refer to the threshold manufacturer's installation instructions for the exact procedure.

### EQUIPMENT AND SUPPLIES

- Caulking gun and caulk
- Concrete screw anchors
- Drill with masonry bits
- Extension cord
- Hacksaw
- Metal threshold and manufacturer's installation instructions
- Personal protective equipment
- Screwdriver
- Screws
- Steel tape

## PROCEDURE

Yes No

- |                          |                          |  |
|--------------------------|--------------------------|--|
| <input type="checkbox"/> | <input type="checkbox"/> | 1. Put on appropriate personal protective equipment.   |
| <input type="checkbox"/> | <input type="checkbox"/> | 2. Read the manufacturer's installation instructions before starting work.   |
| <input type="checkbox"/> | <input type="checkbox"/> | 3. Measure the door opening between the side jambs and transfer the measurement to the threshold.                              |
| <input type="checkbox"/> | <input type="checkbox"/> | 4. Use a hacksaw to cut the threshold to the desired length as required for proper fit.  |
| <input type="checkbox"/> | <input type="checkbox"/> | 5. Cut the opening for the doorstops.  |
| <input type="checkbox"/> | <input type="checkbox"/> | A. Measure the thickness of the doorstop.  |
| <input type="checkbox"/> | <input type="checkbox"/> | B. Mark the thickness of the doorstop from each end.   |
| <input type="checkbox"/> | <input type="checkbox"/> | C. Cut along the line at the mark deep enough to allow for the doorstop when the closed door is centered over the weatherseal. |

**NOTE** ► The threshold should be positioned so that the closed door is approximately centered over the weatherseal. See Figure 1.

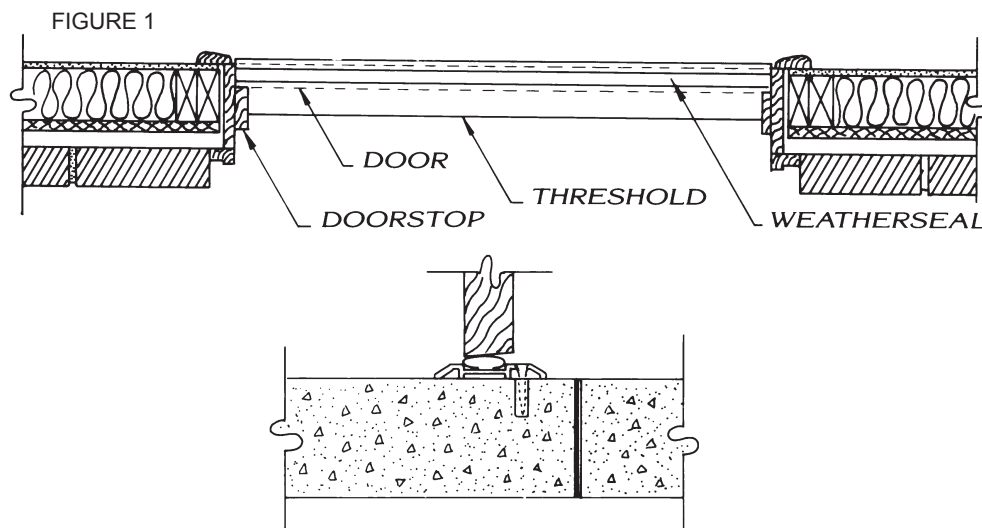

- |                          |                          |   |
|--------------------------|--------------------------|---|
| <input type="checkbox"/> | <input type="checkbox"/> | D. Cut in from each end to provide the notch for doorstops. |
| <input type="checkbox"/> | <input type="checkbox"/> | 6. Place the threshold in position to check for proper fit. |



**Yes No**

- 7. With the threshold in proper position, mark along each edge of the threshold and through screw holes onto the concrete floor.
- 8. Remove threshold.
- 9. Drill holes into the concrete at each screw location, using the proper drill and bit for the anchors being used.
- 10. Clean out each hole, insert anchor in each hole, and tap in place.
- 11. Run a small bead of caulk along the inside of each of the two marked lines on the floor, approximately where the edges of the threshold will rest, and run a bead of caulking material along the ends of the threshold.
- 12. Press the threshold into place.
- 13. Start all screws before tightening evenly.
- 14. Clean up caulk that may have squeezed from under the threshold.
- 15. Clean up area and put away equipment and supplies.

## PRODUCT EVALUATION

### SKILL TEST RECORD

**Evaluator note:** Rate the student on the following criteria by circling the appropriate numbers. Each criterion must receive a rating of “3” or higher to demonstrate student mastery. (See Key below.) A student who is unable to demonstrate mastery should review the material and submit another product for evaluation.

Criteria:

Observe safety procedures	4	3	2	1
Threshold positioned properly	4	3	2	1
Threshold secure	4	3	2	1
Caulking properly applied	4	3	2	1

## AVERAGE RATING

**Evaluator note:** To obtain an average rating for the Profile of Training Mastery, total the points in Product Evaluation and divide by the total number of criteria. Circle the rating on the Key.

## KEY

- 4 Skilled** — Can perform job with no additional training
- 3 Moderately Skilled** — Has performed job during training program; limited additional training may be required
- 2 Limited Skill** — Has performed job during training program; additional training is required to develop skill
- 1 Unskilled** — Is familiar with process, but is unable to perform job

## EVALUATOR'S COMMENTS

---

---

---



Student Name: \_\_\_\_\_ Score: \_\_\_\_\_

**INSTALL AN ENTRY DOOR FRAME, CASING, DOOR, AND LOCK.**

**BASIC SKILLS**



**INTRODUCTION**

This exercise will allow you to develop the skills to install an entry door into a rough opening as well as install the casing and door hardware. The same procedure can be used to install interior doors as well.

**EQUIPMENT AND SUPPLIES**

- 1 x 6 door spreader
- 10d casing nails
- 30" or 78" hand level or jamb level
- 4d, 6d, and 8d finishing nails
- Butt hinges
- Circular saw
- Claw hammer
- Cylindrical lockset with template and manufacturer's installation instructions
- Door
- Door casing
- Door frames
- Door jack
- Door-hanging kit
- Drill and drill bits
- Extension cord
- Flat-blade screwdrivers
- Framing square
- Handsaw



- Nail sets
- Personal protective equipment
- Phillips screwdrivers
- Power miter saw
- Power planer
- Router
- Sawhorses, one pair
- Self-centering punch
- Shims
- Steel tape
- Wood chisels

## PROCEDURE

Yes No

1. Put on personal protective equipment.
2. Check the rough opening for proper dimensions.  
**NOTE ►** Rough openings should be the same size as the door size plus 2½" width and 2" height. The standard thickness for the side jamb is ¾".
3. Check the trimmer studs for plumb.
4. Make sure the floor is level.
5. Assemble and install the door frame.  
**NOTE ►** Check the length of the side jambs with the rough opening. Sometimes it is necessary to cut off part of the lug on the top of the side jambs before assembling. Do not cut off too much of the lug or the assembled frame will not be strong enough.
- A. Fit the head jamb into the dado on the side jambs; glue and nail together with 6d galvanized nails.  
**NOTE ►** If using hardwood drill pilot holes for the nails.
- B. Place the frame in the rough opening.
- C. Center the frame over the opening with the side jambs resting on the floor and the edges flush with the wall face.
- D. Place a spreader on the floor between the side jambs.  
**NOTE ►** The spreader should be the same length as the header between the two side jambs.





Yes No

E. Check to see that the installation is properly aligned and the header is level.

F. Determine the swing of the door from the plans and mark the hinge side on the frame.

G. Secure the frame in the opening using shims at the top and the bottom on both sides of the frame, checking to make sure it is straight and plumb.

H. Adjust the shims to plumb and square the jambs.

I. Temporarily nail side jambs in place remembering not to drive the nails all the way in.

J. Insert shims at each hinge location to adjust for proper clearance.

**NOTE ►** Typically, the top of the upper hinge is located 7" down from the top of the frame, the bottom of the lower hinge is 11" up from the bottom of the door, and if a third hinge is used it is centered between the top and bottom hinges.

K. Use 8d case or finish nails and drive two nails side by side to secure the shims and to keep the jamb from twisting.

L. Follow the same procedure to secure the other side of the jamb making sure to shim the jamb at the strike location.

M. Use intermediate shims wherever needed to make the jamb plumb and square.

N. Recheck the door frame for level, plumb, and square.

O. Trim the shims.

6. Prepare door for installation.

A. Place the door in the door jack.

B. Use a power planer or hand plane to cut the proper bevel.

C. Nail temporary stop blocks on the side jambs to keep the door from going through the hole when you fit it to the opening.

Yes No

- D. Remove the door from the door jack and fit the door to the opening.

**NOTE ▶** The clearance should be  $\frac{1}{8}$ " on the lock side and  $\frac{1}{32}$ " on the hinge side. Leave  $\frac{1}{8}$ " clearance on top and between  $\frac{1}{2}$ " and  $\frac{5}{8}$ " on the bottom. The bottom of the door may need to be trimmed later depending on the floor finish.

- E. Bevel the edge of the door on the lock side to approximately 3 to 5 degrees.

7. Install the butt hinges and hang door.

**NOTE ▶** See the manufacturers instructions for the proper assembly of the router hinge template.

- A. Position the router template on the hinge edge of the door.

- B. Adjust the template to each hinge location.

- C. Set the router for the proper depth of cut.

**NOTE ▶** Check the manufacturers safety instruction before using the router and bit.

- D. Use the router to cut gains for the butt hinges.

- E. Remove the template from the door.

**NOTE ▶** Square the corners if using square butt hinges.

- F. Drill the holes at the screw locations.

- G. Install the hinges on the door with the loose pins toward the top of the door.

- H. Attach the router template to the doorjamb, positioning it to make the matching cuts on the jamb.

- I. Use the router to cut gains on the doorjamb.

- J. Remove the template and drill the holes at the screw locations.

- K. Using the free leaf repeat the same installation procedure for the butt hinge on the doorjamb.





Yes No

L. Remove the door from the door jack and hang it in place.

M. Check the clearance between the door and the doorjamb and make necessary adjustments.

8. Install doorstops.

**NOTE** ► The doorstop is installed with square cuts from one side jamb to the other. Next, the side doorstop is installed with a cope joint at the top and a bevel as the bottom.

A. Measure and cut head stop to size.

B. With the door closed, install the head doorstop with the top against the door on the lock side and  $\frac{1}{16}$ " away from the door on the hinge side; tack the head doorstop in place.

C. Cut a cope joint on top of the side doorstops and check for accuracy over the head doorstop.

D. Cut a bevel on the side doorstops leaving between  $\frac{1}{2}$ " to  $\frac{5}{8}$ " clearance from the floor.

E. Tack the side doorstops in place allowing  $\frac{1}{16}$ " clearance on the hinge side and on the lock side.

9. Install the casing.

**NOTE** ► The casing may be installed with the header casing first or the side jambs first. For this exercise we will install the side casing first.

A. Mark on the doorjamb an appropriate margin between the jamb and the casing.

B. Set a piece of casing on the floor and mark the position of the miter. This is the measurement for the heel of the miter.

C. Miter cut the casing and check it for accuracy.

D. Tack the casing in place.

E. Cut the casing for the opposite side of the door and tack it into place.

Yes No

F. To install the head casing cut a miter on one end of the casing stock.

G. Hold the casing upside down on top of the side casing and mark the toe of the miter. This will be the longest portion of the head casing.

H. Cut the second miter on the head casing.

I. Check for accuracy and make any adjustment.

J. Install the head casing by placing a small amount of adhesive on the miter joints.

**NOTE ►** If using hardwood, drill pilot holes to keep from splitting the wood.

K. Nail the head and side casing with 4d finish nails on the jamb side and 6d finish nails on the wall side. Nail near the ends and about every 16".

**NOTE ►** Nailing too close to the end will split the wood.

L. Use a damp cloth to wipe excess adhesive from the miters if needed.

M. Use a nail set to set all exposed nailheads in the frame and the casing.

10. Install the Lockset.

A. Mark the height of the lock.

**NOTE ►** For this exercise we measure 36" from the floor and mark the door at this point.

B. Wedge the door open so it won't move.

C. If using a template fold the lockset template over the edge of the door at the height line.

D. Mark the center of the strike hole on the door edge and the lockset hole on the face of the door.

E. If using a boring jig you will not need the template.

F. Bore the lockset holes through the door boring half way through on both sides of the door and drill the latch hole through the door edge.





**Yes**   **No**

- |                          |                          |   |
|--------------------------|--------------------------|---|
| <input type="checkbox"/> | <input type="checkbox"/> | G. Mark the location of the latch plate on the door and chisel or route out the mortise.  |
| <input type="checkbox"/> | <input type="checkbox"/> | H. Mark the height and the vertical center for the strike plate and use the center strike template to mark the center point for the boring jig. |
| <input type="checkbox"/> | <input type="checkbox"/> | I. Drill the hole for the strike plate.   |
| <input type="checkbox"/> | <input type="checkbox"/> | J. Cut the mortise for the strike plate and install the strike plate.   |
| <input type="checkbox"/> | <input type="checkbox"/> | K. Install the latch unit.  |
| <input type="checkbox"/> | <input type="checkbox"/> | L. Install the lockset by following manufacturer's instructions.  |
| <input type="checkbox"/> | <input type="checkbox"/> | M. Remove the wedge from the door and make sure the lock works properly.  |
| <input type="checkbox"/> | <input type="checkbox"/> | N. Adjust doorstop if required.   |
| <input type="checkbox"/> | <input type="checkbox"/> | O. Set all doorstop nails.  |
| <input type="checkbox"/> | <input type="checkbox"/> | 11. Clean up area and put away equipment and supplies.  |

## PRODUCT EVALUATION

### SKILL TEST RECORD

**Evaluator note:** Rate the student on the following criteria by circling the appropriate numbers. Each criterion must receive a rating of "3" or higher to demonstrate student mastery. (See Key below.) A student who is unable to demonstrate mastery should review the material and submit another product for evaluation.

Criteria:

Side jambs plumb ( $\frac{1}{16}$ "	4	3	2	1
Side jambs straight ( $\frac{1}{16}$ "	4	3	2	1
Casing miter fitted ( $\frac{1}{32}$ "	4	3	2	1
Door clearance correct ( $\frac{1}{32}$ "	4	3	2	1

Door bevel correct ( $\frac{1}{32}$ "	4	3	2	1
Hinges at proper location ( $\frac{1}{16}$ "	4	3	2	1
Hinge flush with door ( $\frac{1}{32}$ "	4	3	2	1
Doorstop in correct position ( $\frac{1}{16}$ "	4	3	2	1
Lock at correct position ( $\frac{1}{16}$ "	4	3	2	1
Lock tightly fit ( $\frac{1}{16}$ "	4	3	2	1

## AVERAGE RATING

**Evaluator note:** To obtain an average rating for the Profile of Training Mastery, total the points in Product Evaluation and divide by the total number of criteria. Circle the rating on the Key.

## KEY

- 4 Skilled** — Can perform job with no additional training
- 3 Moderately Skilled** — Has performed job during training program; limited additional training may be required
- 2 Limited Skill** — Has performed job during training program; additional training is required to develop skill
- 1 Unskilled** — Is familiar with process, but is unable to perform job

## EVALUATOR'S COMMENTS

---



---



---



Student Name: \_\_\_\_\_ Score: \_\_\_\_\_

**INSTALL AN EXTERIOR PREHUNG DOOR UNIT.****BASIC SKILLS****INTRODUCTION**

This exercise will allow you to develop the skills to install an exterior prehung door unit. The best time to have the prehung doors delivered is after the concrete or plaster is dry. Since these doors are relied upon to perform many functions it is best to guard them against the elements. Always check each door to determine straightness and appearance. The hinge that is used most commonly on exterior doors is the loose-pin butt mortise hinge. The size of the hinge is designated by the length of a leaf in inches. The most common size of hinge recommended is a 3½" or a 4" hinge.

**EQUIPMENT AND SUPPLIES**

- 16d and 8d casing nails
- 30", 4', or 6' hand levels
- 4d and 6d finishing nails
- Caulking gun and sealer
- Claw hammer
- Fiberglass insulation or sill sealer
- Framing square
- Nail sets
- Personal protective equipment
- Prehung door and manufacturer's installation instructions
- Shims
- Steel tape



## PROCEDURE

Yes No

- |                          |                          |  |
|--------------------------|--------------------------|--|
| <input type="checkbox"/> | <input type="checkbox"/> | 1. Put on appropriate personal protective equipment.   |
| <input type="checkbox"/> | <input type="checkbox"/> | 2. Check the prehung door manufacturer's installation instructions for exact procedure.  |
| <input type="checkbox"/> | <input type="checkbox"/> | 3. Remove crate from door unit and check for damage.   |
| <input type="checkbox"/> | <input type="checkbox"/> | 4. Check the rough opening for proper dimensions.<br><b>NOTE</b> ► Rough openings should be the same size as the door size plus $2\frac{1}{4}$ " width and $2\frac{1}{8}$ " height. The standard thickness for the side jamb is $\frac{5}{8}$ ". |
| <input type="checkbox"/> | <input type="checkbox"/> | 5. Check the trimmer studs for plumb.  |
| <input type="checkbox"/> | <input type="checkbox"/> | 6. Make sure the floor is level.   |
| <input type="checkbox"/> | <input type="checkbox"/> | 7. Check the building plans to determine which edge of the door is the hinge edge and which is the lock edge.  |
| <input type="checkbox"/> | <input type="checkbox"/> | 8. Mark both door edges as hinge and lock edges.   |
| <input type="checkbox"/> | <input type="checkbox"/> | 9. Center the door unit temporarily in the opening.  |
| <input type="checkbox"/> | <input type="checkbox"/> | 10. Check to see that the threshold is level and the outside trim is tight against the wall.<br><b>NOTE</b> ► Adjust the level of the opening with shims where required.   |
| <input type="checkbox"/> | <input type="checkbox"/> | 11. With the door unit in the proper position, mark along inside edge of threshold.  |
| <input type="checkbox"/> | <input type="checkbox"/> | 12. Remove the door unit from the opening.   |
| <input type="checkbox"/> | <input type="checkbox"/> | 13. Run a bead of caulk on the floor inside the marked line, approximately where the edges of the threshold will rest and run a bead at the jamb-end locations.  |
| <input type="checkbox"/> | <input type="checkbox"/> | 14. Set the door unit back in the center of the rough opening.   |
| <input type="checkbox"/> | <input type="checkbox"/> | 15. Open the door and recheck the threshold for the level.   |
| <input type="checkbox"/> | <input type="checkbox"/> | 16. Check the header for level.  |
| <input type="checkbox"/> | <input type="checkbox"/> | 17. Temporarily nail the side jambs into place, taking care not to drive the nails all the way in.   |





**Yes**   **No**

- 18. Plumb the hinge jamb by inserting shims at the top of the hinge jamb and slightly above the threshold.
- 19. Nail the jamb into position through the shims and into the trimmer studs.
- 20. Adjust for proper clearance by inserting shims at each hinge.
- 21. Nail the jamb through the hinge shims.  
**NOTE** ▶ One screw may be removed and replaced with a long screw that will help anchor the jamb to the rough frame.
- 22. Insert the shims on the lock jamb, starting at top, then the bottom, then to center at strike location.
- 23. Nail the jamb to the rough framing through each set of shims.  
**NOTE** ▶ It may be necessary to add two more sets of shims between the top and the center and the center and the bottom in order to adjust to the proper clearance.
- 24. Close door and recheck for proper clearance.
- 25. Cut off the shims that may protrude outside of the frame.
- 26. Nail the exterior trim using 8d casing nails spaced about 16" apart.
- 27. Fill the opening between jamb and trimmer studs with fiberglass insulation or sill sealer.
- 28. Install interior trim and lockset.
- 29. Adjust the threshold if necessary by following the manufacturer's instructions.
- 30. Clean up area and put away equipment and supplies.

# PRODUCT EVALUATION

## SKILL TEST RECORD

**Evaluator note:** Rate the student on the following criteria by circling the appropriate numbers. Each criterion must receive a rating of “3” or higher to demonstrate student mastery. (See Key below.) A student who is unable to demonstrate mastery should review the material and submit another product for evaluation.

Criteria:

Observed safety procedures	4	3	2	1
Checked rough opening dimensions	4	3	2	1
Hinge jamb plumb	4	3	2	1
Door operates properly	4	3	2	1
Caulking properly applied	4	3	2	1

## AVERAGE RATING

**Evaluator note:** To obtain an average rating for the Profile of Training Mastery, total the points in Product Evaluation and divide by the total number of criteria. Circle the rating on the Key.

## KEY

- 4 Skilled** — Can perform job with no additional training
- 3 Moderately Skilled** — Has performed job during training program; limited additional training may be required
- 2 Limited Skill** — Has performed job during training program; additional training is required to develop skill
- 1 Unskilled** — Is familiar with process, but is unable to perform job

## EVALUATOR’S COMMENTS

---

---

---

Student Name: \_\_\_\_\_ Score: \_\_\_\_\_

**INSTALL WEATHERSTRIPPING.**

**BASIC SKILLS**



**INTRODUCTION**

As the cost of heating and cooling increases, weatherstripping becomes a cost effective measure. Weatherstripping is narrow strips of material, such as metal, installed around the doors to retard the passage of air, water, moisture, or dust. The weatherstripping should form a seal that compresses against the closed door. This exercise will allow you to develop the skills to install bronze weatherstripping.

**EQUIPMENT AND SUPPLIES**

- Drill and drill bits
- Extension cord
- Miter
- Personal protective equipment
- Screwdriver
- Screws (usually provided with the weatherstripping)
- Steel tape
- Tin snips
- Utility knife
- Weatherstripping and manufacturer's installation instructions

## PROCEDURE

Yes No

- |                          |                          |  |
|--------------------------|--------------------------|--|
| <input type="checkbox"/> | <input type="checkbox"/> | 1. Put on appropriate personal protective equipment.   |
| <input type="checkbox"/> | <input type="checkbox"/> | 2. Cut the weatherstripping to the desired length.   |
| <input type="checkbox"/> | <input type="checkbox"/> | A. Measure between the two side jambs on the part of the header jamb that is not rabbet or does not include the doorstop.  |
| <input type="checkbox"/> | <input type="checkbox"/> | B. Transfer the measurement to the weatherstripping.   |
| <input type="checkbox"/> | <input type="checkbox"/> | C. Cut the metal part of the weatherstripping with the tin snips; use the utility knife to cut the other material on the miter at both ends.                                     |
| <input type="checkbox"/> | <input type="checkbox"/> | D. Measure from the floor to the header on the part of the side jambs that is not rabbeted or does not include a doorstop.   |
| <input type="checkbox"/> | <input type="checkbox"/> | E. Transfer the measurements to the weatherstripping.  |
| <input type="checkbox"/> | <input type="checkbox"/> | F. Cut the weatherstripping as described as above with the miter at the top.   |
| <input type="checkbox"/> | <input type="checkbox"/> | 3. Install the weatherstripping.   |
|                          |                          | <b>NOTE</b> ► Weatherstripping should be attached to the center section of the frame, flush with rabbeted edge or doorstop.  |
| <input type="checkbox"/> | <input type="checkbox"/> | A. Position the header jamb weatherstripping on the jamb with the seal material flush with the rabbet edge or doorstop.  |
| <input type="checkbox"/> | <input type="checkbox"/> | B. Mark the location of the screw slots on the doorjamb and on the nail holes in the weatherstripping.   |
| <input type="checkbox"/> | <input type="checkbox"/> | C. If screws are used for installation, remove the weatherstripping and drill appropriate-sized hole in the center of the marked slots.  |
| <input type="checkbox"/> | <input type="checkbox"/> | D. Position the weatherstripping back on the header and install the screws or nails.   |
|                          |                          | <b>NOTE</b> ► If weatherstripping has slots for adjustment, do not tighten the screws. Leave the weatherstripping so that when ready it can be slipped into the proper position. |





E. Use the same procedure described above to install the weatherstripping on the side jambs.

F. Close the door.

G. For adjustable mountings

- 1) Slide the weatherstripping snug against the door at the header and tighten all of the screws.
- 2) Slide the weatherstripping snug against the door at the side jambs and tighten all of the screws.

H. Open the door and check the weatherstripping for the proper location.

**NOTE** ► Weatherstripping should protrude of the edge approximately  $\frac{1}{8}$ ". For proper fit, the seal should compress against the closed door.

4. Clean up area and put away equipment and supplies.

## PRODUCT EVALUATION

### SKILL TEST RECORD

**Evaluator note:** Rate the student on the following criteria by circling the appropriate numbers. Each criterion must receive a rating of "3" or higher to demonstrate student mastery. (See Key below.) A student who is unable to demonstrate mastery should review the material and submit another product for evaluation.

Criteria:

Observed safety procedures	4	3	2	1
Weatherstripping cut to length ( $\frac{1}{16}$ " )	4	3	2	1
Smooth door operation	4	3	2	1

## AVERAGE RATING

**Evaluator note:** To obtain an average rating for the Profile of Training Mastery, total the points in Product Evaluation and divide by the total number of criteria. Circle the rating on the Key.

## KEY

- 4 **Skilled** — Can perform job with no additional training
- 3 **Moderately Skilled** — Has performed job during training program; limited additional training may be required
- 2 **Limited Skill** — Has performed job during training program; additional training is required to develop skill
- 1 **Unskilled** — Is familiar with process, but is unable to perform job

## EVALUATOR'S COMMENTS

---

---

---



Student Name: \_\_\_\_\_ Score: \_\_\_\_\_

**INSTALL DOOR FRAME AND INSIDE JAMBS FOR AN OVERHEAD DOOR.**

**BASIC SKILLS**



READING



MATHEMATICS



CRITICAL THINKING



EMPLOYABILITY

**INTRODUCTION**

Overhead doors may be either a single-section swing door or multiple sections hinged together. A single section door operates on a pivot principle with the track mounted on the ceiling and rollers located at the center and top of the door. The sectional overhead door has rollers at each section fitted into a track at the side of the door and the ceiling. The sectional overhead door is the most common type used in commercial door installation.

A counter-balance spring is mounted on the sectional overhead door to help support the weight of the door and provide ease of opening. The counter-balance springs may be either torsion or stretch. Always refer to the building plan for exact opening size and requirements. Always refer to the overhead door manufacturer's installation instructions for exact procedures.

**EQUIPMENT AND SUPPLIES**

- 12d or 16d galvanized casing nails
- 2 x 6s for inside jambs
- 2 x 7s for door frames
- 6' stepladder
- Caulk
- Caulking gun



- Circular saw
- Claw hammer
- Extension cord
- Framing square
- Level
- Overhead door and manufacturer's specifications
- Personal protective equipment
- Sawhorses, one pair
- Steel tape
- Wood shingles or shims

## PROCEDURE

Yes No

- |                          |                          |   |
|--------------------------|--------------------------|---|
| <input type="checkbox"/> | <input type="checkbox"/> | 1. Put on appropriate personal protective equipment.  |
| <input type="checkbox"/> | <input type="checkbox"/> | 2. Check the rough opening with the size of the overhead door to ensure proper fit.   |
| <input type="checkbox"/> | <input type="checkbox"/> | 3. Check the side jambs for plumb.  |
| <input type="checkbox"/> | <input type="checkbox"/> | 4. Check the header for level and square.   |
|                          |                          | <b>NOTE ►</b> The rough opening should be the same size as the door size, plus the thickness of the frame, plus the clearance.  |
| <input type="checkbox"/> | <input type="checkbox"/> | 5. Cut the door frame members to size.  |
|                          |                          | <b>NOTE ►</b> The header jamb should be the width of the door plus twice the thickness of the side jamb. The side jambs should be the same as the height of the door. |
| <input type="checkbox"/> | <input type="checkbox"/> | 6. Install the finish header jamb.  |
| <input type="checkbox"/> | <input type="checkbox"/> | A. Determine the height of the finish header.   |
| <input type="checkbox"/> | <input type="checkbox"/> | B. Install the header at the desired height, flush with the interior of the wall.   |
| <input type="checkbox"/> | <input type="checkbox"/> | C. Use the shingles to shim the header level.   |
| <input type="checkbox"/> | <input type="checkbox"/> | D. Nail the header in place and check for level.  |
| <input type="checkbox"/> | <input type="checkbox"/> | 7. Install the finish side jambs.   |
| <input type="checkbox"/> | <input type="checkbox"/> | A. Install the first side jamb flush with the interior wall.  |
| <input type="checkbox"/> | <input type="checkbox"/> | B. Use the shingles to shim the jamb plumb and square.  |
| <input type="checkbox"/> | <input type="checkbox"/> | C. Nail the jamb in place and check for plumb and square.   |





Yes No

D. Install the second side jamb in the same manner.

E. Check the finish opening to see that it is the size of the overhead door.

8. Cut and install the inside casing and track-mounting supports.

**NOTE** ▶ The inside side casing is installed full length between the floor and ceiling.

A. Measure the distance between the floor and the ceiling and cut the side casing to this length.

B. Install the side casing flush with the face of the finish frame.

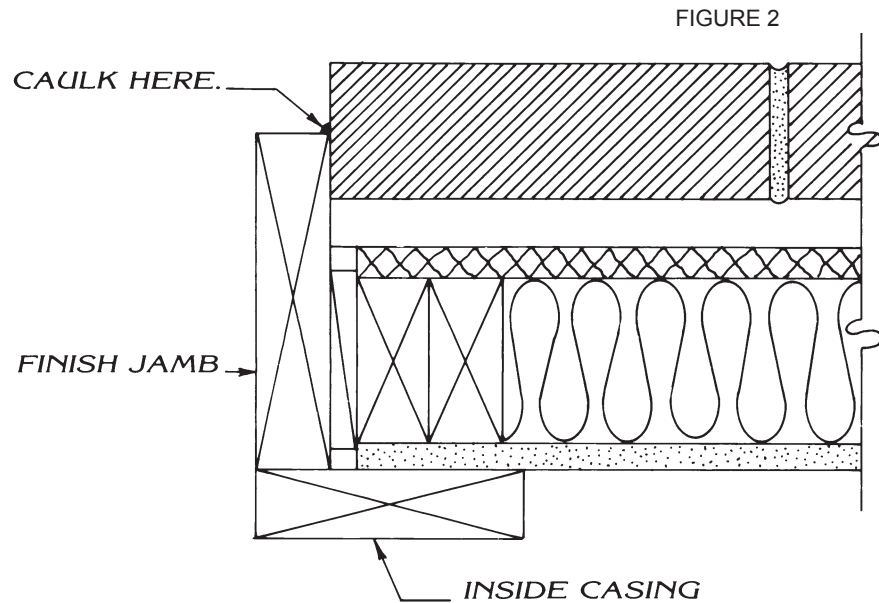

Yes No

C. Cut and install the inside header casing between the two side casings and flush with the face of the finish header.

D. Cut and install the center vertical mounting support between the inside header casing and the ceiling.

- 9. Caulk the outside of the finish door frame between the frame and brick if used.

**NOTE ►** Doorstops will be furnished and installed by the door hanger.

- 10. Check for level, plumb, and square.

- 11. Clean up area and put away equipment and supplies.

## PRODUCT EVALUATION

### SKILL TEST RECORD

**Evaluator note:** Rate the student on the following criteria by circling the appropriate numbers. Each criterion must receive a rating of “3” or higher to demonstrate student mastery. (See Key below.) A student who is unable to demonstrate mastery should review the material and submit another product for evaluation.

Criteria:

Observed safety procedures	4	3	2	1
Checked rough opening dimensions ( $\pm \frac{1}{16}$ "	4	3	2	1
Use of shims to level header	4	3	2	1
Casing and track mounting properly installed	4	3	2	1
Smooth door operation	4	3	2	1
Caulking applied	4	3	2	1

### AVERAGE RATING

**Evaluator note:** To obtain an average rating for the Profile of Training Mastery, total the points in Product Evaluation and divide by the total number of criteria. Circle the rating on the Key.





## KEY

- 4 **Skilled** — Can perform job with no additional training
- 3 **Moderately Skilled** — Has performed job during training program; limited additional training may be required
- 2 **Limited Skill** — Has performed job during training program; additional training is required to develop skill
- 1 **Unskilled** — Is familiar with process, but is unable to perform job

## EVALUATOR'S COMMENTS

---

---

---



# NOTES

---

---

---

---

---

---

---

---

---

---

---

---

---

---

---

---

---

---

---

---

---

---

---



Student Name: \_\_\_\_\_ Score: \_\_\_\_\_

**INSTALL A SPLIT-JAMB PREHUNG DOOR UNIT.**

**BASIC SKILLS**



**INTRODUCTION**

Suppliers normally specify doors as either left or right hand without indicating reverse door swings. The carpenter must order the correct door for the application and install locksets to meet requirements.

**EQUIPMENT AND SUPPLIES**

- 30" hand level
- Claw hammer
- Drill and bits
- Framing, try, and combination squares
- Glue
- Handsaw
- Lockset with template
- Nails
- Nail set
- Personal protective equipment
- Sawhorses, one pair
- Shims
- Split-jamb prehung door unit
- Standard and Phillips screwdrivers
- Steel tape

## PROCEDURE

Yes No

1. Put on appropriate personal protective equipment.

2. Check the rough opening for proper dimensions.

**NOTE ►** Rough openings should be 2½" wider and 2" taller than the door. The standard thickness for the side jamb is ¾".

3. Uncrate the door.

4. Lay the unit on sawhorses with hinges up.

5. Remove small nails driven through jamb into the door on the lock side.

6. Remove the bottom spreader. FIGURE 3

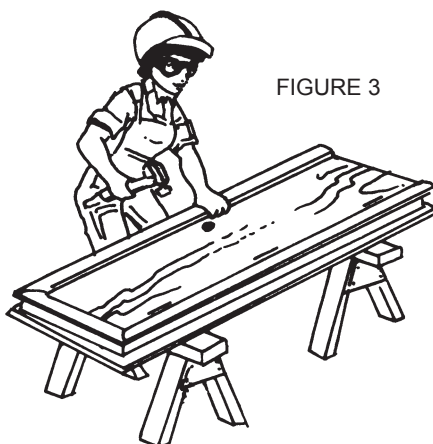

7. Separate the two halves by lifting the top half containing the door.

8. Check for damage.

9. Set the door portion in the rough opening. FIGURE 4

10. Check trim for plumb and clearance at the head and side jamb.





**Yes No**

- 11. Nail the hinge side to the trimmer stud. FIGURE 5
- 12. Using the edge of the door as a margin guide nail the trim on the lock side of the trimmer stud.
- 13. Place shims at top and bottom of the jamb and each hinge on hinge side.
- 14. Place shims at the strike on the lock side.
- 15. Nail through jamb and shims into the trimmer stud.

**CAUTION:** Do not nail through doorstop.

- 16. Insert remaining half of the door unit into grooved section containing the door. FIGURE 6
- NOTE ►** This half will be plumb.
- 17. Nail the casing.
- 18. Nail through stops and into studs. FIGURE 7
- 19. Install the lock following the manufacturer's instructions.
- 20. Check the operation of the door.
- 21. Clean up area and put away equipment and supplies.

FIGURE 5



FIGURE 6



FIGURE 7



**PRODUCT EVALUATION**

**SKILL TEST RECORD**

**Evaluator note:** Rate the student on the following criteria by circling the appropriate numbers. Each criterion must receive a rating of "3" or higher to demonstrate student mastery. (See Key below.) A student who is unable to demonstrate mastery should review the material and submit another product for evaluation.



Criteria:

Door and trim are plumb ( $\frac{1}{16}$ "	4	3	2	1
Proper clearance between door and jamb ( $\frac{1}{32}$ "	4	3	2	1
Shims installed properly	4	3	2	1
No hammer marks	4	3	2	1
Doorlock+ functions properly	4	3	2	1

## AVERAGE RATING

**Evaluator note:** To obtain an average rating for the Profile of Training Mastery, total the points in Product Evaluation and divide by the total number of criteria. Circle the rating on the Key.

## KEY

- 4 **Skilled** — Can perform job with no additional training
- 3 **Moderately Skilled** — Has performed job during training program; limited additional training may be required
- 2 **Limited Skill** — Has performed job during training program; additional training is required to develop skill
- 1 **Unskilled** — Is familiar with process, but is unable to perform job

## EVALUATOR'S COMMENTS

---

---

---



RESIDENTIAL DOOR INSTALLATION  
CARPENTRY SERIES  
**JOB SHEET**

**7**

Student Name: \_\_\_\_\_ Score: \_\_\_\_\_

**INSTALL A SOLID-JAMB DOOR UNIT.**

**BASIC SKILLS**



**INTRODUCTION**

Suppliers normally specify doors as either left or right hand without indicating reverse door swings. The carpenter must order the correct door for the application and install locksets to meet requirements.

**EQUIPMENT AND SUPPLIES**

- 30" hand level and 6' straight edge or jamb level
- Claw hammer
- Framing and combination squares
- Handsaw
- Lockset with template
- Nails
- Nail set
- Personal protective equipment
- Shims
- Solid-jamb prehung door unit
- Steel tape

## PROCEDURE

Yes No

- |                          |                          |  |
|--------------------------|--------------------------|--|
| <input type="checkbox"/> | <input type="checkbox"/> | 1. Put on personal protective equipment.   |
| <input type="checkbox"/> | <input type="checkbox"/> | 2. Check the rough opening for proper dimensions.<br><b>NOTE ►</b> Rough openings should be 2½" wider and 2" taller than the door. The standard thickness for the side jamb is ¾".   |
| <input type="checkbox"/> | <input type="checkbox"/> | 3. Uncrate the door.   |
| <input type="checkbox"/> | <input type="checkbox"/> | 4. Check for damage.   |
| <input type="checkbox"/> | <input type="checkbox"/> | 5. Set the unit centered in the opening with installed trim tight against the wall.  |
| <input type="checkbox"/> | <input type="checkbox"/> | 6. Check for proper fit and alignment.   |
| <input type="checkbox"/> | <input type="checkbox"/> | 7. Open door and place a spreader on the floor between the two side jambs.<br><b>NOTE ►</b> Spreader should be the exact length of the header jamb between the two side jambs.   |
| <input type="checkbox"/> | <input type="checkbox"/> | 8. Temporarily nail the side jambs to hold the unit in place. Do not drive nails all the way in.   |
| <input type="checkbox"/> | <input type="checkbox"/> | 9. Insert shims at the top and bottom of the hinge jamb until plumb.   |
| <input type="checkbox"/> | <input type="checkbox"/> | 10. Nail jamb at each hinge.   |
| <input type="checkbox"/> | <input type="checkbox"/> | 11. Insert shims on the lock jamb starting at the top, then the bottom, and finally at the center at the strike location.  |
| <input type="checkbox"/> | <input type="checkbox"/> | 12. Nail lock jamb to rough framing through each set of shims.<br><b>NOTE ►</b> It may be necessary to add two additional sets of shims between the top and center and bottom and center in order to adjust the proper door clearance. |
| <input type="checkbox"/> | <input type="checkbox"/> | 13. Remove the spreader and check the door for proper door clearance.  |
| <input type="checkbox"/> | <input type="checkbox"/> | 14. Cut off any shims that may protrude outside the frame.   |





- 15. Nail trim to other side of door, spacing nails about every 16".
- 16. Set nails.
- 17. Install the lock following the manufacturers instructions.
- 18. Clean up area and put away equipment and supplies.

## PRODUCT EVALUATION

### SKILL TEST RECORD

**Evaluator note:** Rate the student on the following criteria by circling the appropriate numbers. Each criterion must receive a rating of "3" or higher to demonstrate student mastery. (See Key below.) A student who is unable to demonstrate mastery should review the material and submit another product for evaluation.

Criteria:

Proper swing	4	3	2	1
Proper edge clearance ( $\frac{3}{32}$ " )	4	3	2	1
Shims installed properly	4	3	2	1
Door opens/closes properly	4	3	2	1
Nails in proper location and set	4	3	2	1

### AVERAGE RATING

**Evaluator note:** To obtain an average rating for the Profile of Training Mastery, total the points in Product Evaluation and divide by the total number of criteria. Circle the rating on the Key.

## KEY

- 4 **Skilled** — Can perform job with no additional training
- 3 **Moderately Skilled** — Has performed job during training program; limited additional training may be required
- 2 **Limited Skill** — Has performed job during training program; additional training is required to develop skill
- 1 **Unskilled** — Is familiar with process, but is unable to perform job

## EVALUATOR'S COMMENTS

---

---

---



Student Name: \_\_\_\_\_ Score: \_\_\_\_\_

**INSTALL INTERIOR DOOR FRAME, DOOR, LOCK, AND TRIM.**

**BASIC SKILLS**



**INTRODUCTION**

As with exterior doors, interior doors usually come in flush and panel styles. Most standard interior doors are 1 $\frac{3}{8}$ " thick. Common widths for single interior doors are 2' 6" for bedrooms and other habitable rooms. Bathrooms are 2' 4" with small closets and linen closets generally at 2'.

Installing an interior door frame, door, lock, and trim is very similar to installing an exterior door. Always refer to the building plans for specific door hand and specifications. Always follow the manufacturer's instructions and details included with each lockset to install the lockset. Follow the manufacturer's instructions for adjusting the lock.

**EQUIPMENT AND SUPPLIES**

- 30" hand level
- 4d and 6d finish nails
- 6' straight edge or jamb level
- 8d casing nails
- Butt hinges
- Claw hammer
- Door
- Door casing

- Door jack
- Doorjamb
- Door spreader
- Door-hanging kit
- Drill & drill bits
- Extension cord
- Flat screwdrivers
- Framing square
- Glue
- Hand plane
- Handsaw or circular saw
- Lockset with template
- Nail sets
- Personal protective equipment
- Phillips screwdrivers
- Power miter saws
- Power planer
- Router with hinge-mortising bit
- Sawhorses, one pair
- Self-centering punch
- Shims
- Steel tape
- Utility knife
- Wood chisel

## PROCEDURE

Yes No

1. Put on personal protective equipment.
2. Check the rough opening for proper dimensions.
- NOTE ►** Rough openings should be the same size as the door size plus 2½" width and 2" height. The standard thickness for the side jamb is ¾".
3. Check the trimmer studs for plumb.
4. Make sure the floor is level.
5. Assemble and install the door frame.
- NOTE ►** Check the length of the side jambs with the rough opening. Sometimes it is necessary to cut off part of the lug on the top of the side jambs before assembling. Do not cut off too much of the lug or the assembled frame will not be strong enough.
- A. Fit the head jamb into the dado on the side jambs; glue and nail together with 6d galvanized nails.
- NOTE ►** If using hardwood drill pilot holes for the nails.
- B. Place the frame in the rough opening.





Yes No

C. Center the frame over the opening with the side jambs resting on the floor and the edges flush with the wall face.

D. Place a spreader on the floor between the side jambs.

**NOTE ►** The spreader should be the same length as the header between the two side jambs.

E. Check to see that the installation is properly aligned and the header is level.

F. Determine the swing of the door from the plans and mark the hinge side on the frame.

G. Secure the frame in the opening using shims at the top and the bottom on both sides of the frame, checking to make sure it is straight and plumb.

H. Adjust the shims to plumb and square the jambs.

I. Temporarily nail side jambs in place remembering not to drive the nails all the way in.

J. Insert shims at each hinge location to adjust for proper clearance.

**NOTE ►** Typically, the top of the upper hinge is located 7" down from the top of the frame, the bottom of the lower hinge is 11" up from the bottom of the door, and if a third hinge is used it is centered between the top and bottom hinges.

K. Use 8d case or finish nails and drive two nails side by side to secure the shims and to keep the jamb from twisting.

L. Follow the same procedure to secure the other side of the jamb making sure to shim the jamb at the strike location.

M. Use intermediate shims wherever needed to make the jamb plumb and square.

N. Recheck the door frame for level, plumb, and square.

O. Trim the shims.



Yes No

6. Prepare door for installation.
- A. Place the door in the door jack.
- B. Use a power planer or hand plane to cut the proper bevel.
- C. Nail temporary stop blocks on the side jambs to keep the door from going through the hole when you fit it to the opening.
- D. Remove the door from the door jack and fit the door to the opening.
- NOTE ►** The clearance should be  $\frac{1}{8}$ " on the lock side and  $\frac{1}{32}$ " on the hinge side. Leave  $\frac{1}{8}$ " clearance on top and between  $\frac{1}{2}$ " and  $\frac{5}{8}$ " on the bottom. The bottom of the door may need to be trimmed later depending on the floor finish.
- E. Bevel the edge of the door on the lock side to approximately 3 to 5 degrees.

7. Install the butt hinges and hang door.
- NOTE ►** See the manufacturers instructions for the proper assembly of the router hinge template.
- A. Position the router template on the hinge edge of the door.
- B. Adjust the template to each hinge location.
- C. Set the router for the proper depth of cut.
- NOTE ►** Check the manufacturers safety instruction before using the router and bit.
- D. Use the router to cut gains for the butt hinges.
- E. Remove the template from the door.
- NOTE ►** Square the corners if using square butt hinges.
- F. Drill the holes at the screw locations.
- G. Install the hinges on the door with the loose pins toward the top of the door.





Yes No

H. Attach the router template to the doorjamb, positioning it to make the matching cuts on the jamb.

I. Use the router to cut gains on the doorjamb.

J. Remove the template and drill the holes at the screw locations.

K. Using the free leaf repeat the same installation procedure for the butt hinge on the doorjamb.

L. Remove the door from the door jack and hang it in place.

M. Check the clearance between the door and the doorjambs and make necessary adjustments.

8. Install doorstops.

**NOTE ►** The doorstop is installed with square cuts from one side jamb to the other. Next, the side doorstop is installed with a cope joint at the top and a bevel as the bottom.

A. Measure and cut head stop to size.

B. With the door closed, install the head doorstop with the top against the door on the lock side and  $\frac{1}{16}$ " away from the door on the hinge side; tack the head doorstop in place.

C. Cut a cope joint on top of the side doorstops and check for accuracy over the head doorstop.

D. Cut a bevel on the side doorstops leaving between  $\frac{1}{2}$ " to  $\frac{5}{8}$ " clearance from the floor.

E. Tack the side doorstops in place allowing  $\frac{1}{16}$ " clearance on the hinge side and on the lock side.

9. Install the casing.

**NOTE ►** The casing may be installed with the header casing first or the side jambs first. For this exercise we will install the side casing first.

A. Mark on the doorjamb an appropriate margin between the jamb and the casing.

Yes No

B. Set a piece of casing on the floor and mark the position of the miter. This is the measurement for the heel of the miter.

C. Miter cut the casing and check it for accuracy.

D. Tack the casing in place.

E. Cut the casing for the opposite side of the door and tack it into place.

F. To install the head casing cut a miter on one end of the casing stock.

G. Hold the casing upside down on top of the side casing and mark the toe of the miter. This will be the longest portion of the head casing.

H. Cut the second miter on the head casing.

I. Check for accuracy and make any adjustment.

J. Install the head casing by placing a small amount of adhesive on the miter joints.

**NOTE ►** If using hardwood, drill pilot holes to keep from splitting the wood.

K. Nail the head and side casing with 4d finish nails on the jamb side and 6d finish nails on the wall side. Nail near the ends and about every 16".

**NOTE ►** Nailing too close to the end will split the wood.

L. Use a damp cloth to wipe excess adhesive from the miters if needed.

M. Use a nail set to set all exposed nailheads in the frame and the casing.

10. Install the Lockset.

A. Mark the height of the lock.

**NOTE ►** For this exercise we measure 36" from the floor and mark the door at this point.





**Yes**   **No**

B. Wedge the door open so it won't move.

C. If using a template fold the lockset template over the edge of the door at the height line.

D. Mark the center of the strike hole on the door edge and the lockset hole on the face of the door.

E. If using a boring jig you will not need the template.

F. Bore the lockset holes through the door boring half way through on both sides of the door and drill the latch hole through the door edge.

G. Mark the location of the latch plate on the door and chisel or route out the mortise.

H. Mark the height and the vertical center for the strike plate and use the center strike template to mark the center point for the boring jig.

I. Drill the hole for the strike plate.

J. Cut the mortise for the strike plate and install the strike plate.

K. Install the latch unit.

L. Install the lockset by following manufacturer's instructions.

M. Remove the wedge from the door and make sure the lock works properly.

N. Adjust doorstop if required.

O. Set all doorstop nails.

11. Clean up area and put away equipment and supplies.

## PRODUCT EVALUATION

### SKILL TEST RECORD

**Evaluator note:** Rate the student on the following criteria by circling the appropriate numbers. Each criterion must receive a rating of "3" or higher to demonstrate student mastery. (See Key below.) A student who is unable to demonstrate mastery should review the material and submit another product for evaluation.

Criteria:

Side jambs plumb ( $\frac{1}{16}$ "	4	3	2	1
Side jambs straight ( $\frac{1}{16}$ "	4	3	2	1
Casing miter fitted ( $\frac{1}{32}$ "	4	3	2	1
Door clearance correct ( $\frac{1}{32}$ "	4	3	2	1
Door bevel correct ( $\frac{1}{32}$ "	4	3	2	1
Hinges at proper location ( $\frac{1}{16}$ "	4	3	2	1
Hinge flush with door ( $\frac{1}{32}$ "	4	3	2	1
Doorstop in correct position ( $\frac{1}{16}$ "	4	3	2	1
Lock at correct position ( $\frac{1}{16}$ "	4	3	2	1
Lock tightly fit ( $\frac{1}{16}$ "	4	3	2	1

### AVERAGE RATING

**Evaluator note:** To obtain an average rating for the Profile of Training Mastery, total the points in Product Evaluation and divide by the total number of criteria. Circle the rating on the Key.





## KEY

- 4 **Skilled** — Can perform job with no additional training
- 3 **Moderately Skilled** — Has performed job during training program; limited additional training may be required
- 2 **Limited Skill** — Has performed job during training program; additional training is required to develop skill
- 1 **Unskilled** — Is familiar with process, but is unable to perform job

## EVALUATOR'S COMMENTS

---

---

---



Student Name: \_\_\_\_\_ Score: \_\_\_\_\_

**INSTALL A BIFOLD DOOR UNIT.**

**BASIC SKILLS**



**INTRODUCTION**

The following steps are to be used as a guideline when installing a bifold door unit. Always follow the installation and adjustment instructions provided by the manufacturer.

**EQUIPMENT AND SUPPLIES**

- 30" hand level and 6' straight edge or jamb level
- Bifold door unit
- Claw hammer
- Drill and bits
- Framing and combination squares
- Glue
- Handsaw
- Nails
- Nail set
- Power miter saw
- Personal protective equipment
- Shims
- Standard and Phillips screwdrivers
- Steel tape



## PROCEDURE

Yes No

- |                          |                          |   |
|--------------------------|--------------------------|---|
| <input type="checkbox"/> | <input type="checkbox"/> | 1. Put on personal protective equipment.              |
| <input type="checkbox"/> | <input type="checkbox"/> | 2. Install doorjamb if not already installed.         |
| <input type="checkbox"/> | <input type="checkbox"/> | 3. Install door track.                                |
| <input type="checkbox"/> | <input type="checkbox"/> | 4. Install pivot brackets in frame.                   |
| <input type="checkbox"/> | <input type="checkbox"/> | 5. Install pivots and door aligners on door.          |
| <input type="checkbox"/> | <input type="checkbox"/> | 6. Install doors.                                     |
| <input type="checkbox"/> | <input type="checkbox"/> | 7. Adjust doors to proper fit.                        |
| <input type="checkbox"/> | <input type="checkbox"/> | 8. Install casing.                                    |
| <input type="checkbox"/> | <input type="checkbox"/> | 9. Clean up area and put away equipment and supplies. |

## PRODUCT EVALUATION

### SKILL TEST RECORD

**Evaluator note:** Rate the student on the following criteria by circling the appropriate numbers. Each criterion must receive a rating of “3” or higher to demonstrate student mastery. (See Key below.) A student who is unable to demonstrate mastery should review the material and submit another product for evaluation.

Criteria:

Door aligned in frame (Per manufacturer’s specs.)	4	3	2	1
Door clearances correct (Per manufacturer’s specs.)	4	3	2	1
Door operates smoothly	4	3	2	1
Casing installed properly	4	3	2	1





## AVERAGE RATING

**Evaluator note:** To obtain an average rating for the Profile of Training Mastery, total the points in Product Evaluation and divide by the total number of criteria. Circle the rating on the Key.

## KEY

- 4 Skilled** — Can perform job with no additional training
- 3 Moderately Skilled** — Has performed job during training program; limited additional training may be required
- 2 Limited Skill** — Has performed job during training program; additional training is required to develop skill
- 1 Unskilled** — Is familiar with process, but is unable to perform job

## EVALUATOR'S COMMENTS

---

---

---



Student Name: \_\_\_\_\_ Score: \_\_\_\_\_

**INSTALL A POCKET DOOR UNIT.**

**BASIC SKILLS**



**INTRODUCTION**

Pocket door frames are normally installed during the framing phase of construction. The following steps are to be used as a guideline when installing a pocket door unit. Always follow the installation and adjustment instructions provided by the manufacturer.

**EQUIPMENT AND SUPPLIES**

- 2' 6" x 6' 8" pocket door unit
- 3/4" stock for base plate (or floor anchor) and screws and anchors if necessary
- 30" hand level and 6' straight edge or jamb level
- Claw hammer
- Drill and bits
- Framing and combination squares
- Glue
- Handsaw
- Nails
- Nail set
- Power miter saw
- Personal protective equipment
- Shims
- Standard and Phillips screwdrivers
- Steel tape
- Utility knife

## PROCEDURE

Yes No

- |                          |                          |   |
|--------------------------|--------------------------|---|
| <input type="checkbox"/> | <input type="checkbox"/> | 1. Put on personal protective equipment.  |
| <input type="checkbox"/> | <input type="checkbox"/> | 2. Check rough opening for proper dimensions, trimmer studs for plumb, and header for level and square. |
| <input type="checkbox"/> | <input type="checkbox"/> | 3. Set frame unit in opening.   |
| <input type="checkbox"/> | <input type="checkbox"/> | 4. Install frame.   |
| <input type="checkbox"/> | <input type="checkbox"/> | 5. Cut base plate to fit between side frames in pocket section.   |
| <input type="checkbox"/> | <input type="checkbox"/> | 6. Install base plate on the floor using glue and appropriate anchors, depending on type of floor.      |
| <input type="checkbox"/> | <input type="checkbox"/> | 7. Nail side frames to the base plate.  |
| <input type="checkbox"/> | <input type="checkbox"/> | 8. Install wall material over frame.  |
|                          |                          | <b>CAUTION:</b> Do not drive nails from wall material into the door.                                    |
| <input type="checkbox"/> | <input type="checkbox"/> | 9. Install casing.  |
| <input type="checkbox"/> | <input type="checkbox"/> | 10. Clean up area and put away equipment and supplies.  |

## PRODUCT EVALUATION

### SKILL TEST RECORD

**Evaluator note:** Rate the student on the following criteria by circling the appropriate numbers. Each criterion must receive a rating of “3” or higher to demonstrate student mastery. (See Key below.) A student who is unable to demonstrate mastery should review the material and submit another product for evaluation.





Criteria:

Head jamb level ( $\frac{1}{8}$ "	4	3	2	1
Side jambs plumb ( $\frac{1}{8}$ "	4	3	2	1
Jamb joints tight ( $\frac{1}{32}$ "	4	3	2	1
Door slides freely	4	3	2	1
Proper reveals ( $\frac{1}{8}$ "	4	3	2	1
Thumb-pull installed properly	4	3	2	1

## AVERAGE RATING

**Evaluator note:** To obtain an average rating for the Profile of Training Mastery, total the points in Product Evaluation and divide by the total number of criteria. Circle the rating on the Key.

## KEY

- 4 Skilled** — Can perform job with no additional training
- 3 Moderately Skilled** — Has performed job during training program; limited additional training may be required
- 2 Limited Skill** — Has performed job during training program; additional training is required to develop skill
- 1 Unskilled** — Is familiar with process, but is unable to perform job

## EVALUATOR'S COMMENTS

---

---

---



# **RESIDENTIAL ROOF FRAMING**

**CARPENTRY SERIES**





# RESIDENTIAL ROOF FRAMING CARPENTRY SERIES JOB SHEET

# 1

Student Name: \_\_\_\_\_ Score: \_\_\_\_\_

## LAY OUT RAFTER LOCATIONS ON THE TOP PLATE AND RIDGEBOARD ON 2' CENTERS.

### BASIC SKILLS



### EQUIPMENT AND SUPPLIES

- Circular saw and extension cord
- Completed wall sections with double top plate
- Framing square
- Personal protective equipment
- Ridgeboard material
- Steel tape

### PROCEDURE

See FIGURE 8  
for an example.

- NOTE** ► This procedure is for laying out a gable roof with box cornice and may be done while laying out ceiling joists. For clarification, ceiling joist marks are NOT shown in illustrations.

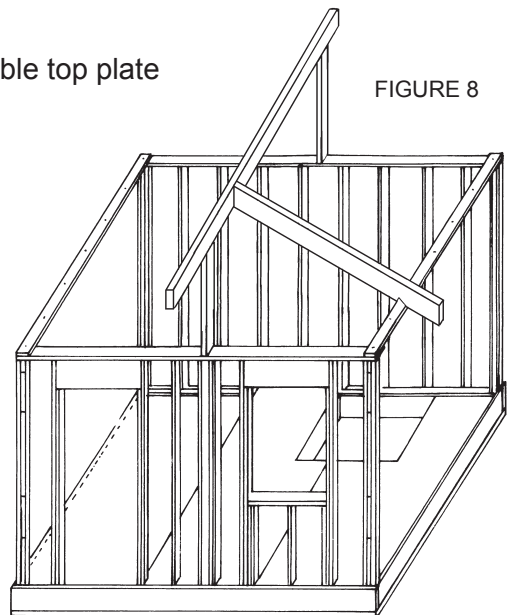

Yes No

- |                          |                          |   |
|--------------------------|--------------------------|---|
| <input type="checkbox"/> | <input type="checkbox"/> | 1. Put on personal protective equipment.  |
| <input type="checkbox"/> | <input type="checkbox"/> | 2. Cut ridgeboard to correct length, allowing for barge rafter at each end if used.   |
| <input type="checkbox"/> | <input type="checkbox"/> | 3. Lay out rafter locations on double top plate.  |
| <input type="checkbox"/> | <input type="checkbox"/> | A. Begin at one end of top plate and locate first rafter flush with end of top plate.   |
| <input type="checkbox"/> | <input type="checkbox"/> | B. Use steel tape with the "0" held against the left outside end of wall to mark 2' locations on top plate; mark an "R" to the right of mark. See Figure 9. |
| <input type="checkbox"/> | <input type="checkbox"/> | C. Set last rafter flush with instruments outside of opposite end of structure.   |
|                          |                          | <b>NOTE ►</b> The spacing between the last two rafters may be less than, but not more than 2'.  |
| <input type="checkbox"/> | <input type="checkbox"/> | D. Use framing square to square a line across top plate at each 2' mark.  |
| <input type="checkbox"/> | <input type="checkbox"/> | E. Repeat the marking process on opposite top plate, being sure to start from same end of structure; work from right to left.                               |

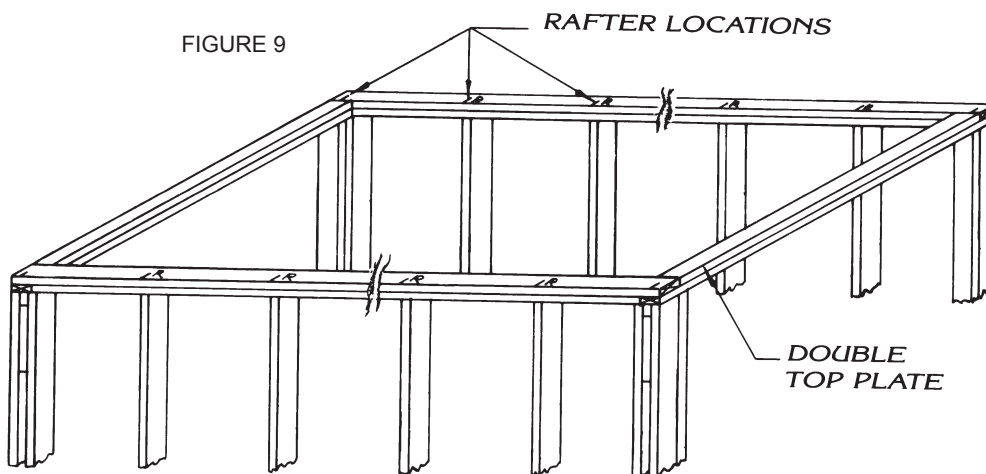



Yes No

- 4. Lay out ridgeboard
- A. Place ridgeboard on edge of top plate with required projection at each end.
- B. Mark ridgeboard on both sides to correspond to marks on top plate.
- C. Use framing square to square lines across each face of ridgeboard at each mark, and write an "R" (rafter) to the right of each mark as for the top plate.
- 5. Clean up area and put away equipment and supplies.

## PRODUCT EVALUATION

### SKILL TEST RECORD

**Evaluator note:** Rate the student on the following criteria by circling the appropriate numbers. Each criterion must receive a rating of "3" or higher to demonstrate student mastery. (See Key below.) A student who is unable to demonstrate mastery should review the material and submit another product for evaluation.

Criteria:

Observed safety procedures	4	3	2	1
Used proper equipment correctly	4	3	2	1
Performed steps in a timely manner	4	3	2	1
Followed instructions	4	3	2	1
Provided satisfactory responses to questions asked	4	3	2	1

### AVERAGE RATING

**Evaluator note:** To obtain an average rating for the Profile of Training Mastery, total the points in Product Evaluation and divide by the total number of criteria. Circle the rating on the Key.

## KEY

- 4 **Skilled** — Can perform job with no additional training
- 3 **Moderately Skilled** — Has performed job during training program; limited additional training may be required
- 2 **Limited Skill** — Has performed job during training program; additional training is required to develop skill
- 1 **Unskilled** — Is familiar with process, but is unable to perform job

## EVALUATOR'S COMMENTS

---

---

---

Student Name: \_\_\_\_\_ Score: \_\_\_\_\_

**LAY OUT, CUT, AND INSTALL CEILING JOISTS AND ERECT  
RAFTERS FOR GABLE ROOFS.**

**BASIC SKILLS**



**Words You  
Should Know**

**Crown**

the slight convex  
edge of a framing  
member

**INTRODUCTION**

In this exercise you will be constructing a roof with an 8 and 12 slope. Ceiling joists are installed after the walls are erected and before the roof is framed.

**EQUIPMENT AND SUPPLIES**

- 16d box nails
- 25' tape with markings at 16" centers
- Chalk line
- Circular handsaw and extension cord
- Framing hammer
- Framing square or speed square
- Joists, lengths, and sizes as specified
- Personal protective equipment
- Steel tape

## PROCEDURE

Yes No

1. Put on all personal protective equipment.
2. Determine which direction the joist will run.  
**NOTE** ▶ They are usually placed parallel to the shortest dimension of the structure; however, refer to the plans.
3. Lay out the joist and rafter locations on the double top plate.
4. Measure 15¼" from the end of the outside corner to the closest edge of the first joist.
5. Drive a nail and hook the end of the tape to the nail.
6. Lay out for 16" centers and place an "X" on the side where the joist will be placed and place an "R" on the side where the rafter will be located.
7. Repeat steps 4 - 6 on the opposite wall or on the bearing partition.  
**NOTE** ▶ Be sure to reverse the measuring procedure.

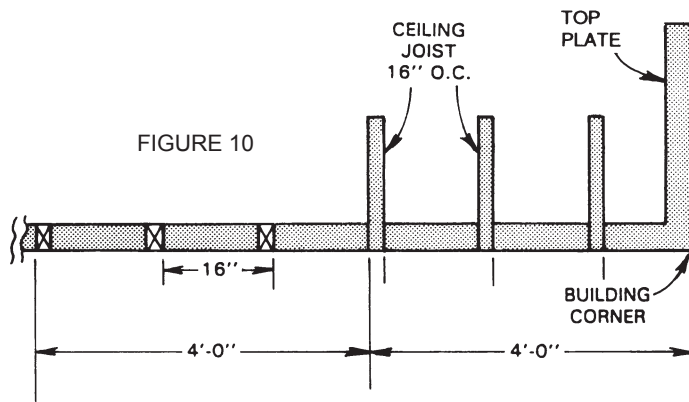

8. Lay out the ridgeboard to equal the length of the building plus the overhang.
9. Mark the ridgeboard with 16" centers. See Figure 11.

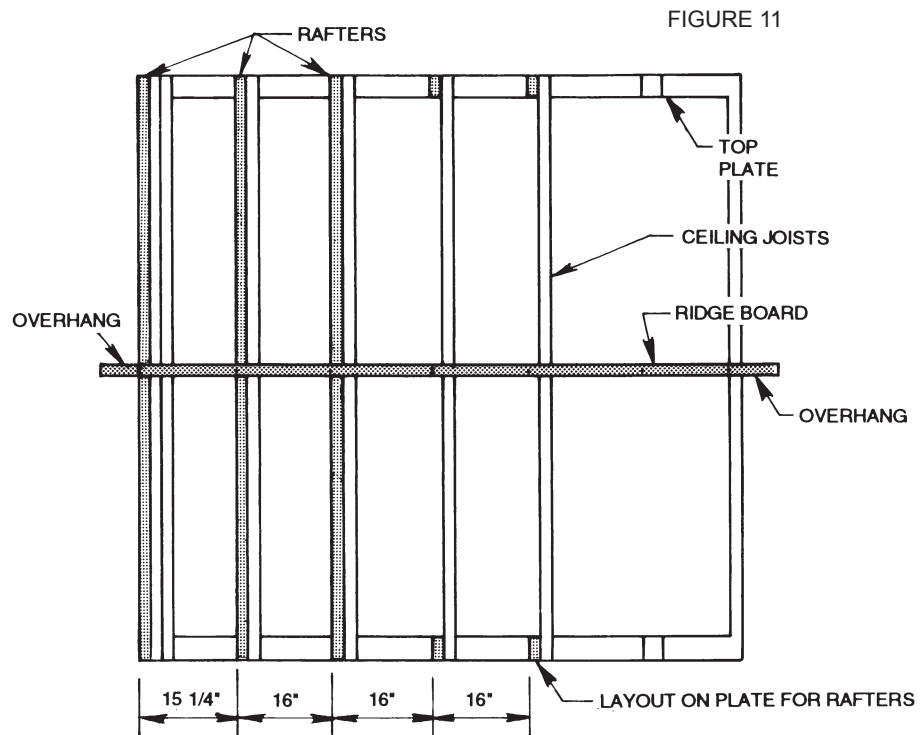

**Yes No**

10. Install the ceiling joists. See Figures 12 and 13.

A. Be sure the crown is up.

B. Cut the joist to the proper length and to the approximate pitch of the roof.

C. Place one joist, crown up, on each mark that was made on the plate.

**NOTE ►** If the building span is wider than the length of the joist material, you must lap the joist on the interior bearing wall. When this occurs, ceiling joists must be placed on opposing sides of rafters.

D. Toenail the joist to the plate with three 16d nails. See Figure 16.

E. Continue installing the ceiling joists until all are installed.



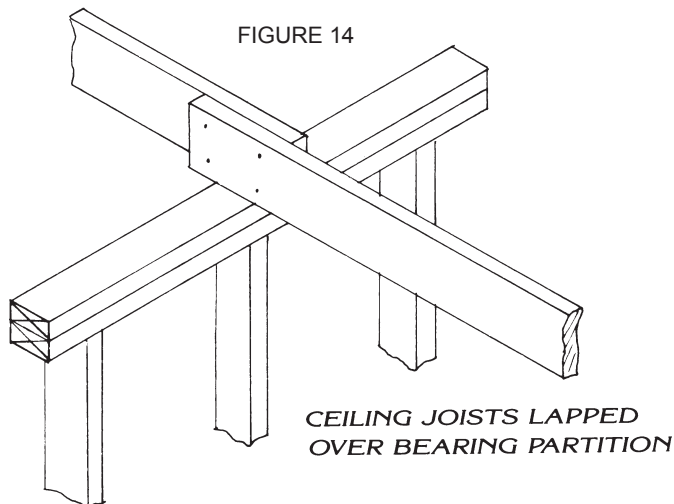
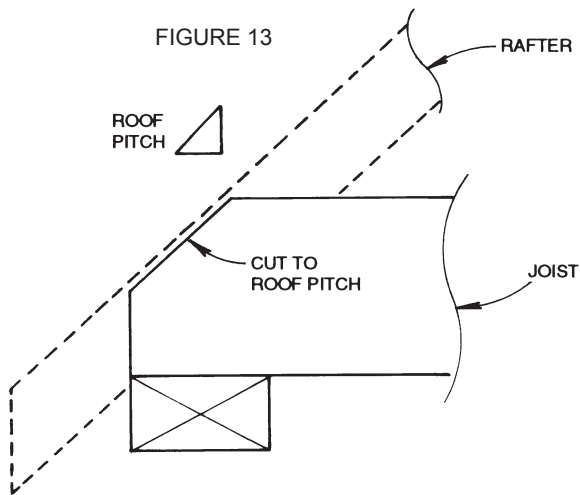
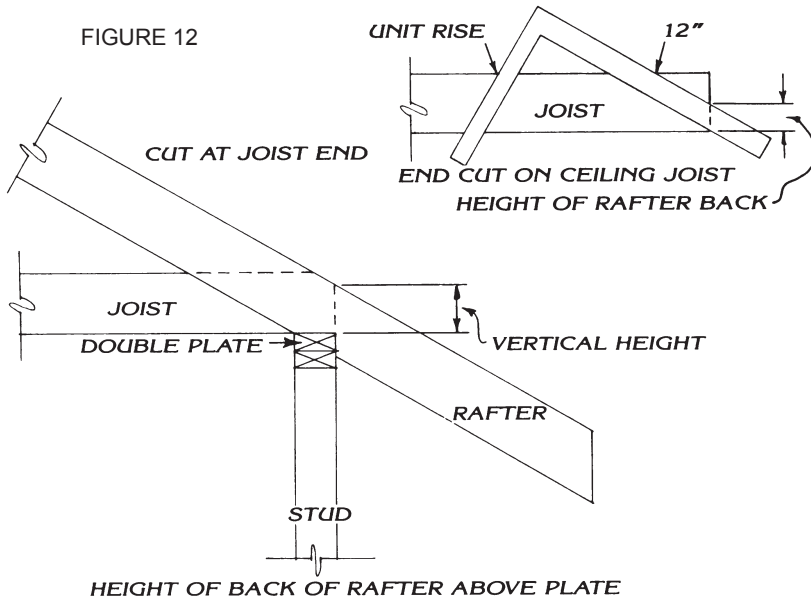



FIGURE 15

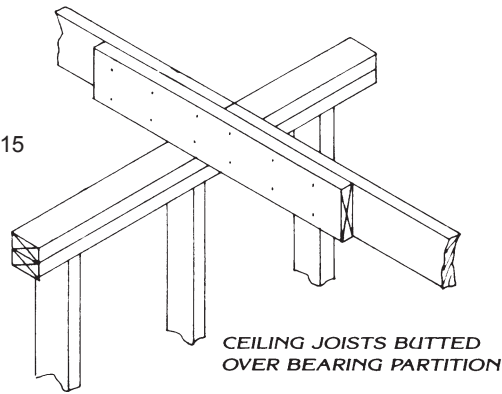
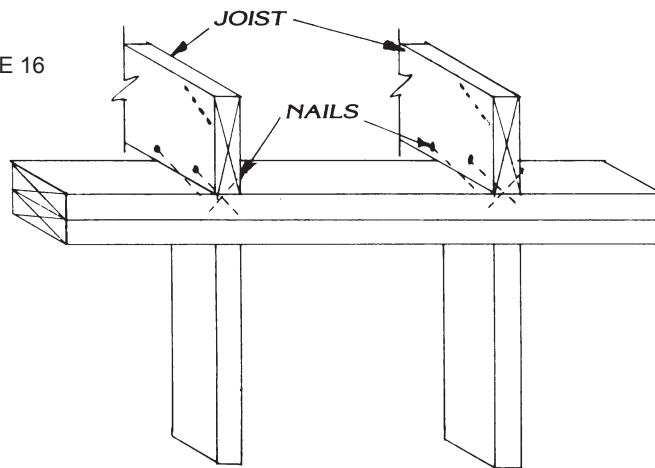

FIGURE 16



Yes No

11. Lay out, cut, and erect the rafters.

**NOTE ►** Before completing the next stage of construction, you should be familiar with common roofing terminology such as span, run, rise, and pitch. Knowledge of these terms will aid understanding and reading rafter tables. Ask your instructor or supervisor for an explanation if you do not understand these terms.

A. Lay out and cut a pattern for the common rafters.

- 1) Use a framing square or rafter table to calculate the length of the rafter.
- 2) Subtract the length of the rafter by  $\frac{1}{2}$  the thickness of the ridgeboard.

- 3) Select lumber long enough for a common rafter, including the overhang, and lay it across two sawhorses.
- 4) Use the framing square to mark the top end of the plumb cut using the following steps:
  - a. Determine the crown edge of the rafter.
  - b. Make sure the toe or long point of the plumb cut is on the crown edge.
  - c. Place the framing square across the face of the rafter near one end.

**NOTE ►** The blade runs lengthwise with the rafter and the tongue runs across the face of the rafter.
  - d. Locate the inches of rise per foot of run on the tongue of the framing square.
  - e. Locate the inches of run on the blade.

**NOTE ►** For common rafters the run will always be 12" for a gable roof.
  - f. Mark the rafter on the outside edge of framing-square tongue.
  - g. Measure the length of the rafter on the top edge from the toe of the plumb cut.
  - h. Measure the thickness of the ridge board and deduct  $\frac{1}{2}$  that distance from the length of the rafter.

**NOTE ►** Measure perpendicular to the plumb cut.
  - i. Place the framing square in position to mark the plumb cut for the bird's mouth.

**NOTE ►** The bird's mouth should not exceed  $\frac{1}{3}$  the width of the material.
  - j. Place the framing square in position to mark the seat cut for the bird's mouth and mark the seat cut.
  - k. Mark the rafter on the outside edge of framing-square tongue.
- 5) Cut only part of the bird's mouth with the circular saw, following safety procedure.

**NOTE ►** An accurate cut on this first piece is important because it will be the pattern for cutting and remaining common rafters.



Yes No

6) Finish each cut with a handsaw.

7) Write "pattern" on both sides.

B. Use your pattern to mark and cut the remaining common rafters.

**NOTE** ► While marking, be sure to keep the top flush at the bird's mouth.

12. Frame the gable roof.

A. Place boards across the ceiling joists to walk on.

B. Lean all the rafters against the sides of the structure at each joist. Place them so the rafter plumb cut is up.

C. Complete ridgeboard preparation.

D. Nail one rafter at each end of the ridgeboard.

E. Lift the ridgeboard into a temporary position.

F. Nail bird's mouth cuts to the top plate.

G. Nail bird's mouths of opposing rafters to the top plate.

H. Toenail plumb cuts of opposing rafters to the ridgeboard.

I. Use a temporary brace to hold the ridgeboard in place vertically until the nailing is completed.

**NOTE** ► It may also be checked by stretching a string along the top over the center of the ridgeboard.

J. Install temporary lateral bracing in order to plumb the end rafters.

K. Erect the remaining rafters, including the end rafters.

13. Frame the gable end.

A. With all rafters erected, install purlins, strongbacks, and collar beams, as required.

B. Replace the temporary lateral bracing.

14. Trim the rafter tails.
- NOTE ►** Build a platform or erect a scaffold and assume a comfortable and safe position before starting each cut.
- A. Mark the length of each end rafter at the determined length.
- B. Chalk a line on top of all rafters to locate the cutting line.
- C. Mark the side of each rafter with the framing square for a square end cut or plumb cut.
- D. Cut off the tails with a circular saw.
15. Nail sub (or false) fascia to the ends of all the rafters around the perimeter.
- NOTE ►** On a gable roof like this one, allow the ends to extend far enough for the barge rafter.
16. Install the barge rafters.
- NOTE ►** The barge rafters have no bird's mouth cut.
17. Clean up area and put away equipment and supplies.

## PRODUCT EVALUATION

### SKILL TEST RECORD

**Evaluator note:** Rate the student on the following criteria by circling the appropriate numbers. Each criterion must receive a rating of "3" or higher to demonstrate student mastery. (See Key below.) A student who is unable to demonstrate mastery should review the material and submit another product for evaluation.



Criteria:

Observed safety procedures	4	3	2	1
Used proper equipment correctly	4	3	2	1
Performed steps in a timely manner	4	3	2	1
Followed instructions	4	3	2	1
Provided satisfactory responses to questions asked	4	3	2	1

## AVERAGE RATING

**Evaluator note:** To obtain an average rating for the Profile of Training Mastery, total the points in Product Evaluation and divide by the total number of criteria. Circle the rating on the Key.

## KEY

- 4 Skilled** — Can perform job with no additional training
- 3 Moderately Skilled** — Has performed job during training program; limited additional training may be required
- 2 Limited Skill** — Has performed job during training program; additional training is required to develop skill
- 1 Unskilled** — Is familiar with process, but is unable to perform job

## EVALUATOR'S COMMENTS

---

---

---



Student Name: \_\_\_\_\_ Score: \_\_\_\_\_

**FRAME A GABLE END WITH A VENT OPENING.**

**BASIC SKILLS**



**Words You  
Should Know**

**Cripple Stud**

a stud that is  
shorter than full  
length

**EQUIPMENT AND SUPPLIES**

- 16d and 8d nails
- 100' tape
- Circular saw and extension cord
- Framing hammer
- Framing square
- Hand level
- Handsaw
- Plumb bob and line
- Pencil
- Personal protective equipment
- Specifications (furnished by instructor)
- Steel tape
- Stud material



## PROCEDURE

Yes No

- |                          |                          |   |
|--------------------------|--------------------------|---|
| <input type="checkbox"/> | <input type="checkbox"/> | 1. Put on all the appropriate personal protective equipment.  |
| <input type="checkbox"/> | <input type="checkbox"/> | 2. Plumb down from the center of the gable to the top of the end-wall top plate.                                  |
| <input type="checkbox"/> | <input type="checkbox"/> | 3. Square a line across the end-wall top plate at this mark.  |
| <input type="checkbox"/> | <input type="checkbox"/> | 4. Lay out a vent opening by measuring out from the center line one half of the opening size needed for the vent. |
| <input type="checkbox"/> | <input type="checkbox"/> | 5. Perform this same step on the other side of the center line.   |
| <input type="checkbox"/> | <input type="checkbox"/> | 6. Lay out and mark the stud locations directly above the wall studs.   |
| <input type="checkbox"/> | <input type="checkbox"/> | 7. Stand a stud upright at the first mark and plumb it.   |
| <input type="checkbox"/> | <input type="checkbox"/> | 8. Mark across the edge of the stud at the underside of the rafter.   |

**NOTE** ► This mark will give you the correct cutting angle.

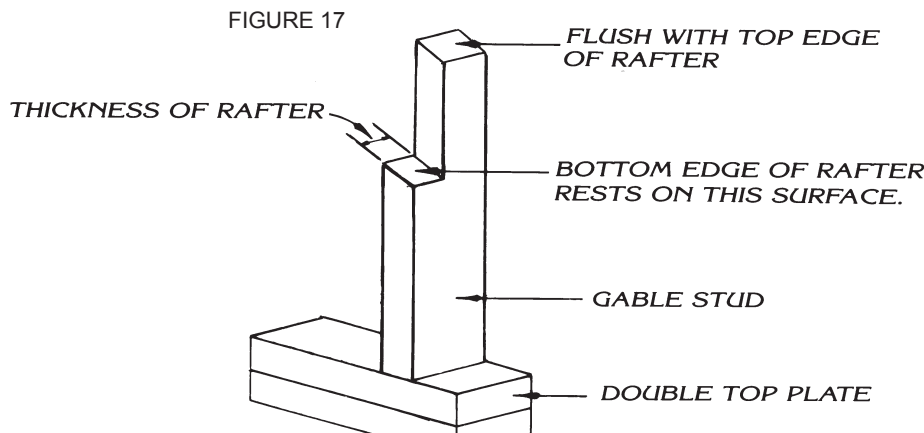

- |                          |                          |  |
|--------------------------|--------------------------|--|
| <input type="checkbox"/> | <input type="checkbox"/> | 9. Continue to mark the remaining stud locations.            |
| <input type="checkbox"/> | <input type="checkbox"/> | 10. Cut all the studs to length following safety procedures. |
- NOTE** ► Make the notch cut as deep as the thickness of the rafter.
- |                          |                          |   |
|--------------------------|--------------------------|---|
| <input type="checkbox"/> | <input type="checkbox"/> | A. Keep the electric cord free of the blade.            |
| <input type="checkbox"/> | <input type="checkbox"/> | B. Be sure the automatic guard is free and retractable. |



- C. Never lock the automatic guard in the retracted position.
- D. Check the stock for nails, metal, or concrete before cutting.
- E. Make sure the blade is sharp and in good condition.
- F. Use good, solid support for the stock while cutting.
- G. Set the blade deep enough to cut through the stock only.
- H. Lay the saw on its base after finishing the cut.

FIGURE 18

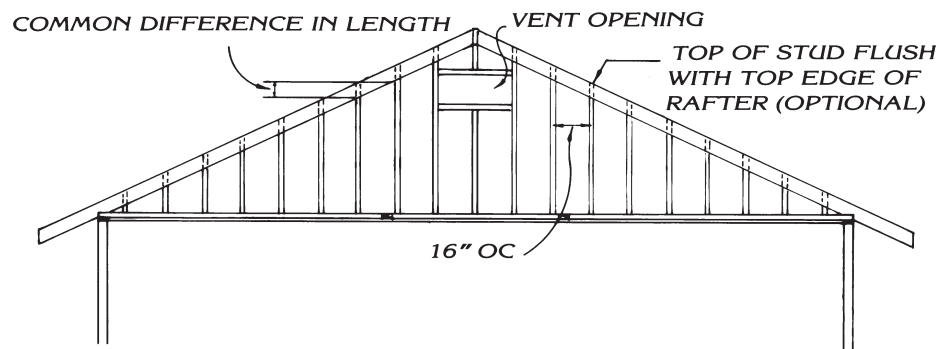

- 11. Plumb studs and nail them into position.
- 12. Measure, cut, and nail in a header.
- 13. Nail a sill for the vent.
- 14. Lay out, cut, and nail the cripple studs above and below the vent opening, directly above the studs in the wall.
- 15. Clean up area and put away equipment and supplies.

# PRODUCT EVALUATION

## SKILL TEST RECORD

**Evaluator note:** Rate the student on the following criteria by circling the appropriate numbers. Each criterion must receive a rating of “3” or higher to demonstrate student mastery. (See Key below.) A student who is unable to demonstrate mastery should review the material and submit another product for evaluation.

Criteria:

Observed safety procedures	4	3	2	1
Used proper equipment correctly	4	3	2	1
Performed steps in a timely manner	4	3	2	1
Followed instructions	4	3	2	1
Provided satisfactory responses to questions asked	4	3	2	1

## AVERAGE RATING

**Evaluator note:** To obtain an average rating for the Profile of Training Mastery, total the points in Product Evaluation and divide by the total number of criteria. Circle the rating on the Key.

## KEY

- 4 Skilled** — Can perform job with no additional training
- 3 Moderately Skilled** — Has performed job during training program; limited additional training may be required
- 2 Limited Skill** — Has performed job during training program; additional training is required to develop skill
- 1 Unskilled** — Is familiar with process, but is unable to perform job



## EVALUATOR'S COMMENTS

---

---

---



Student Name: \_\_\_\_\_ Score: \_\_\_\_\_

**LAY OUT AND CUT CEILING JOISTS AND RAFTERS FOR HIP ROOFS.**

**BASIC SKILLS**



**INTRODUCTION**

A hip roof is made up of common rafters, a ridgeboard, hip rafters, jack rafters and end common rafters. The procedures described in this job sheet require care and practice. To illustrate calculations, an example will be used throughout the job sheet. The example consists of a structure with an 8 and 12 slope. Your instructor may have you construct these rafters for practice or apply the procedures to other rafters.

**EQUIPMENT AND SUPPLIES**

- 8d and 16d box nails
- 100' tape
- Chalk line
- Circular saw and extension cord
- Framing hammer
- Framing square
- Handsaw
- Rafter tables booklet
- Pencil
- Personal protective equipment
- Rafter materials
- Ridgeboard material
- Sawhorses (2)
- Steel tape
- String line

## PROCEDURE

Yes No

1. Put on personal protective equipment.  
**NOTE** ▶ Refer to Tables 1 and 2 at the end of this unit if necessary.
2. Determine which direction the rafters and joists will run.  
**NOTE** ▶ They are usually parallel to the shortest dimension of the structure; however, refer to the plan.
3. Lay out the common rafter locations for the hip roof.  
**NOTE** ▶ The remaining rafters locations will be laid out later.
4. Measure the width or span of the structure and determine the run.

FIGURE 19

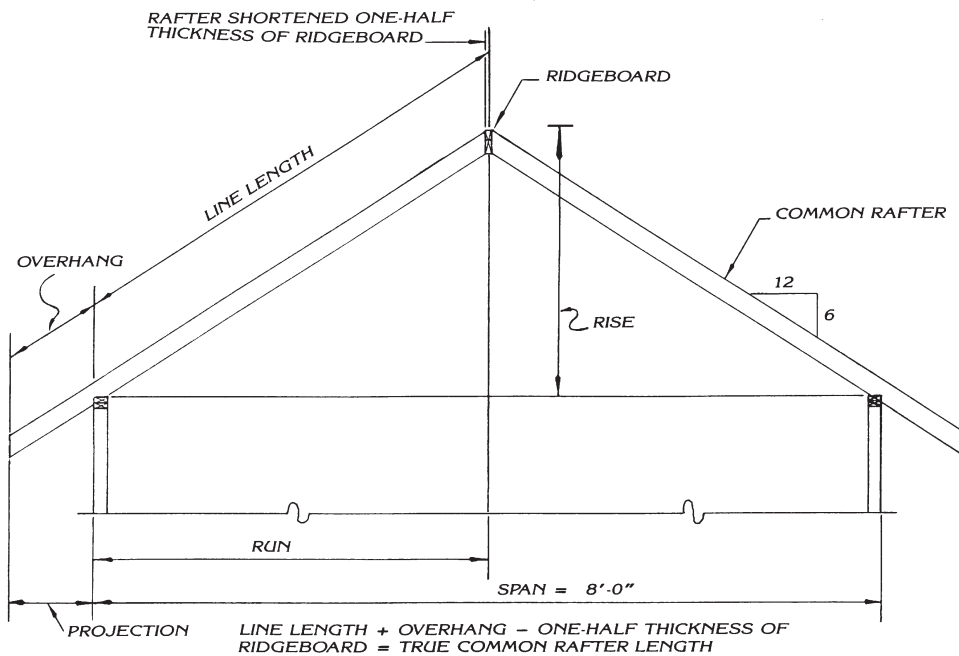

5. Measuring from the corners, layoff and mark the distance of the run on both the end and side walls.  
**NOTE** ▶ These marks will show the location of the center of common rafters and the end common rafter.



Yes No

6. Lay out the remainder of the common rafters and joists in both directions at 16" centers. Measure from the center of the common rafters that you previously marked.

7. Lay out the joist locations for the hip roof.

**NOTE** ► The location of the first joist will be on the hip end of the structure next to the first common rafter.

A. Designate the common and jack rafters.

B. Lay out the location of the jack rafter and stub joist on the end wall.

**NOTE** ► Notice that the stub joist is laid out to be installed next to the end common rafter.

C. Repeat these steps on the opposite end until all ceiling joists are marked.

8. Cut and install the ceiling joists.

A. Making sure the crowns are up, cut the joists to their proper length and their ends to the approximate pitch of the roof.

B. Place one joist, crown up, on each mark that was made on the plate.

C. Lap the joist on the bearing walls.

**NOTE** ► Remember, there should be a minimum overlap of 6".

D. Toenail the joist to the plate with three nails.

E. Continue installing the ceiling joists until this portion of the job is completed.

F. Cut and install stub joists on the hip end of the structure.

9. Layout and cut the common rafters using the following steps.

**NOTE** ► Earlier you laid out the common rafter locations.

10. Determine the length of the rafters by using a framing square or a rafter table.

**NOTE** ► Subtract the length of the rafter by  $\frac{1}{2}$  the thickness of the ridgeboard.



FIGURE 20

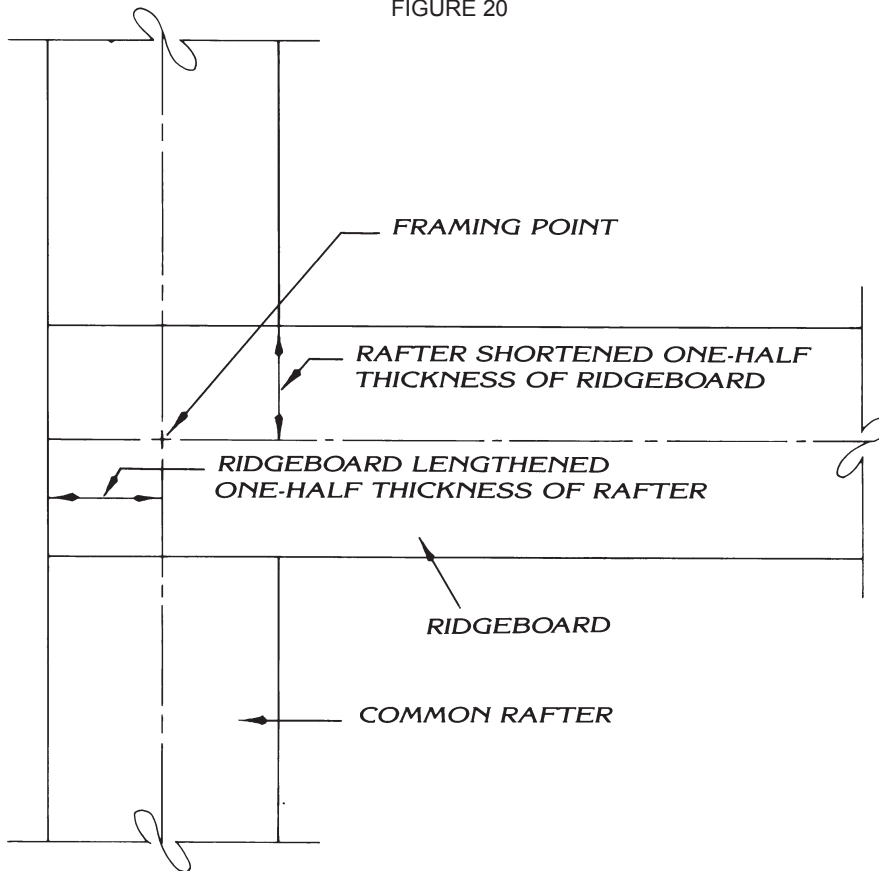

Yes No

- |                          |                          |   |
|--------------------------|--------------------------|---|
| <input type="checkbox"/> | <input type="checkbox"/> | 11. Select a rafter long enough for a common rafter, including the overhang, and lay it across two sawhorses. |
| <input type="checkbox"/> | <input type="checkbox"/> | 12. Use the framing square to mark the top end of the plumb cut, using the following steps.                   |
| <input type="checkbox"/> | <input type="checkbox"/> | A. Determine the crown edge of the rafter.  |
| <input type="checkbox"/> | <input type="checkbox"/> | B. Make sure the toe of the plumb cut is on the crown edge.   |
| <input type="checkbox"/> | <input type="checkbox"/> | C. Place the framing square across the face of the rafter near one end.                                       |
|                          |                          | <b>NOTE</b> ► The blade runs lengthwise with the rafter and the tongue runs across the face of the rafter.    |
| <input type="checkbox"/> | <input type="checkbox"/> | D. Locate the inches of rise per foot of run on the tongue of the framing square.                             |



Yes No

E. Locate inches of run on the blade.

F. Mark the rafter on the outside edge of framing-square tongue.

G. After marking the end of the plumb cut, measure the length of the rafter on the top edge from the toe of the plumb cut.

H. Consider the thickness of the ridge board by measuring the thickness of the ridge board and deducting  $\frac{1}{2}$  that distance from the length of the rafter.

**NOTE** ▶ This must be done perpendicular to the plumb cut.

I. Place the framing square in position to mark the plumb cut for the bird's mouth.

**NOTE** ▶ The bird's mouth should not exceed  $\frac{1}{3}$  the width of the material.

J. Place the framing square in position and mark the seat cut for the bird's mouth.

13. Cut the rafter.

**NOTE** ▶ Get an accurate cut on this first piece because it will be the pattern for cutting the remaining common rafters.

14. Cut only part of the bird's mouth with the power hand saw, following safety procedures.

A. Keep the electric cord free of the blade.

B. Be sure the automatic guard is free and retractable.

C. Never lock the automatic guard in the retracted position.

D. Check the stock for nails, metal, or concrete before cutting.

E. Make sure the blade is sharp and in good condition.

F. Use good, solid support for the stock while cutting.

G. Set the blade deep enough to cut through the stock only.

H. Lay the saw on its side after finishing the cut.

**Yes No**

15. Finish the cut with a handsaw.
16. Write "pattern" on both sides.
17. Use the pattern to mark and cut the remaining common rafters.
- NOTE ►** Be sure to keep the top flush at the bird's mouth while marking.
18. Stack the completed common rafters.
19. Layout and cut hip rafters using the following steps.
20. Determine the length of the rafters by using a framing square or a rafter table.
- NOTE ►** In laying out a hip rafter subtract the length of the rafter by  $\frac{1}{2}$  the diagonal thickness of the ridgeboard. For a  $1\frac{1}{2}$ " ridgeboard this measurement is commonly  $1\frac{1}{16}$ ".
21. Determine the amount to shorten the length of the rafter. Determine the length of the hip rafter and subtract  $\frac{1}{2}$  the diagonal dimension of the ridgeboard perpendicular to the plumb cut.
22. Select a rafter long enough for a hip rafter, including the overhang, and lay it across two sawhorses.
23. Use the framing square to mark the top end of the plumb cut, using the following steps.
- A. Determine the crown edge of the rafter.
- B. Make sure the toe of the plumb cut is on the crown edge.
- C. Place the framing square across the face of the rafter near one end.
- NOTE ►** The blade runs lengthwise with the rafter and the tongue runs across the face of the rafter.
- D. Locate the inches of rise per foot of run on the tongue of the framing square.
- E. Locate inches of run on the blade. For hip rafters the run will always be 17".

Yes No

F. Mark the rafter on the outside edge of framing-square tongue. This establishes the center line of the plumb cut. See Figures 21 and 22.

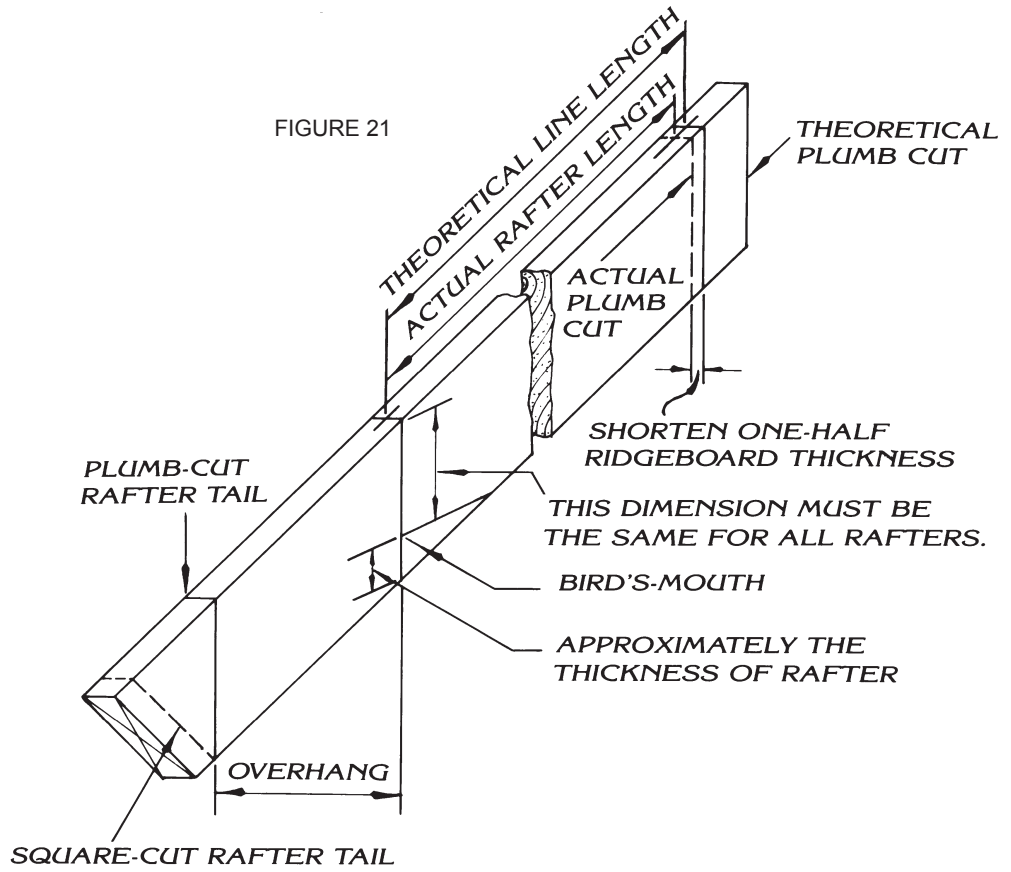
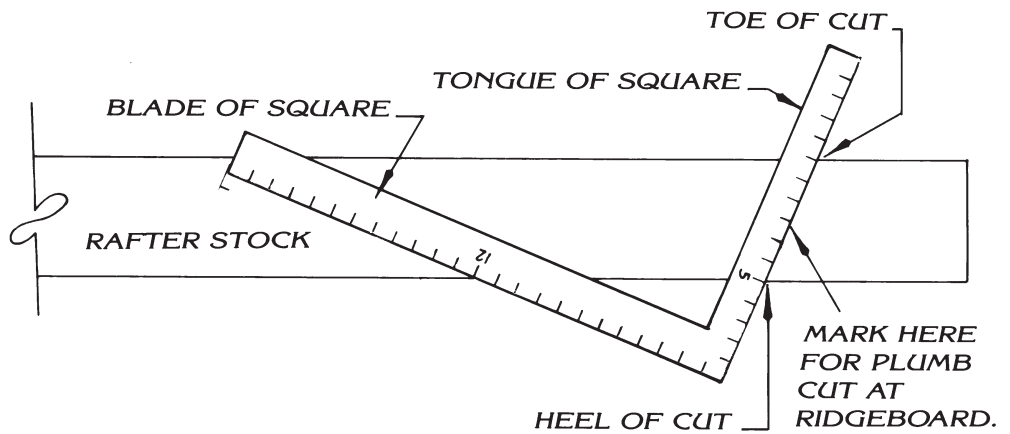

FIGURE 22



Yes No

G. After marking the end of the plumb cut, measure the length of the rafter on the top edge from the toe of the plumb cut. See Figure 23.

H. Place the framing square in position to mark the plumb cut for the bird's mouth.

**NOTE** ▶ For the hip rafter the bird's mouth should be dropped  $\frac{3}{8}$ " on  $1\frac{1}{2}$ " material. The vertical distance between the top of the bird's mouth and the top of the rafter will be  $\frac{3}{8}$ " less than that of a common rafter. See Figure 24.

FIGURE 23

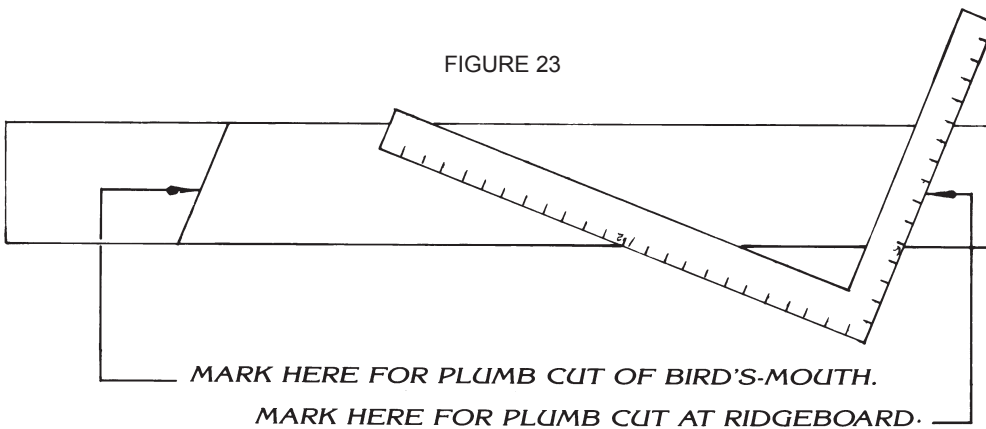
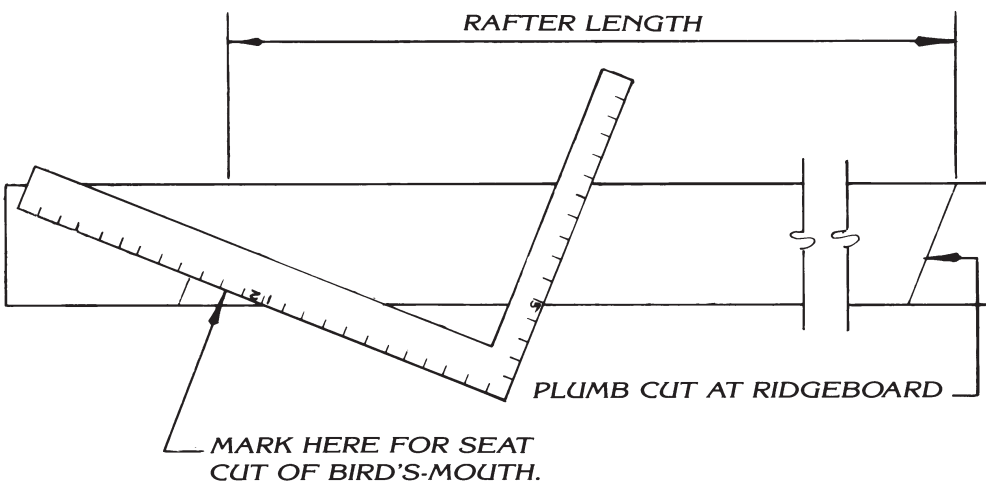

FIGURE 24





Yes No



1. Place the framing square in position and mark the seat cut for the bird's mouth.



24. Cut the hip rafter.

**NOTE** ► Get an accurate cut on this first piece because it will be the pattern for cutting the remaining common rafters. See Figure 25.

FIGURE 25

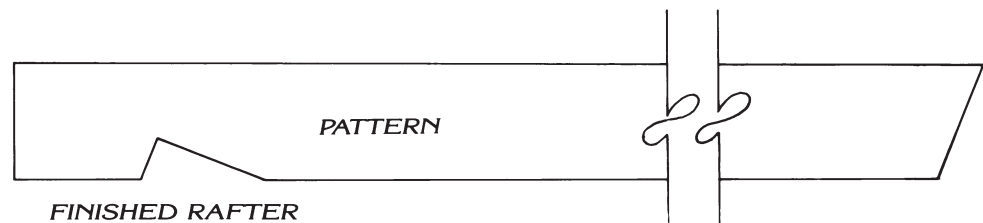

25. Cut only part of the bird's mouth with the power hand saw.



26. Finish the cut with a handsaw.



27. Write "pattern" on both sides.



28. Use the pattern to mark and cut the remaining hip rafters.

**NOTE** ► Be sure to keep the top flush at the bird's mouth while marking.



29. Stack the completed hip rafters.



30. Layout and cut jack rafters using the following steps.

**NOTE** ► Layout the jack rafters on 16" centers.



A. Determine the length of the first jack rafter by using a framing square or a rafter table.

**NOTE** ► This is the jack rafter closest to the length of the end common rafter.

**REMEMBER:** The figure read from the framing square is the difference in length of jack rafters from the common rafters.

Yes No

B. Use the pattern for the common rafters to mark the bird's mouth.

C. Measure the length of the first jack rafter from the plumb cut of the bird's mouth.

**NOTE ►** This length is the theoretical length of the jack rafter. The actual length must be shortened by  $\frac{1}{2}$  the diagonal thickness of the hip rafter.

D. Shorten the rafter.

E. Determine the length of the remaining jack rafters and cut all jack rafters.

**NOTE ►** For every jack rafter with a cheek cut on the left there must be one with a cheek cut on the right.

F. Determine the length of the ridgeboard by taking the length of the building minus the span plus the thickness of the ridgeboard.

31. Stack the completed jack rafters.

32. Clean up area and put away equipment and supplies.

## PRODUCT EVALUATION

### SKILL TEST RECORD

**Evaluator note:** Rate the student on the following criteria by circling the appropriate numbers. Each criterion must receive a rating of "3" or higher to demonstrate student mastery. (See Key below.) A student who is unable to demonstrate mastery should review the material and submit another product for evaluation.



Criteria:

Observed safety procedures	4	3	2	1
Used proper equipment correctly	4	3	2	1
Performed steps in a timely manner	4	3	2	1
Followed instructions	4	3	2	1
Provided satisfactory responses to questions asked	4	3	2	1

## AVERAGE RATING

**Evaluator note:** To obtain an average rating for the Profile of Training Mastery, total the points in Product Evaluation and divide by the total number of criteria. Circle the rating on the Key.

## KEY

- 4 Skilled** — Can perform job with no additional training
- 3 Moderately Skilled** — Has performed job during training program; limited additional training may be required
- 2 Limited Skill** — Has performed job during training program; additional training is required to develop skill
- 1 Unskilled** — Is familiar with process, but is unable to perform job

## EVALUATOR'S COMMENTS

---

---

---





Student Name: \_\_\_\_\_ Score: \_\_\_\_\_

## **ERECT CEILING JOISTS AND RAFTERS FOR HIP ROOFS.**

### **BASIC SKILLS**



### **INTRODUCTION**

Once the rafters and joists have been cut following the steps in Job Sheet 4 then follow the steps listed in this job sheet to erect those roof members. As always care should be taken when working above the ground to avoid injury to yourself and your coworkers.

### **EQUIPMENT AND SUPPLIES**

- 8d and 16d box nails
- 100' tape
- Chalk line
- Circular saw and extension cord
- Framing hammer
- Framing square
- Handsaw
- Rafter tables booklet
- Pencil
- Personal protective equipment
- Rafter materials
- Ridgeboard material
- Sawhorses (2)
- Steel tape
- String line

## PROCEDURE

Yes No

1. Put on personal protective equipment.

2. Erect the rafters by using the following steps.

**NOTE ►** Erect the rafters in order beginning with opposing common rafters on both ends, then the other common rafters, followed by the hip, hip jack, and then the remaining rafters.

3. Place boards across the ceiling joists to walk on.

4. Lean all the rafters against the sides of the structure at each location mark. Place them so the ridgeboard plumb cut it up.

5. Nail one rafter at each end of the ridgeboard.

6. Lift the ridgeboard into a temporary position.

7. Nail bird's mouth cuts to the top plate.

8. Use a temporary brace to hold the ridgeboard in place until the nailing is completed.

9. Nail bird's mouths of opposing rafters to the top plate.

10. Toenail plumb cuts of opposing rafters to the ridgeboard.

11. Erect the end common rafters being sure that the top of the rafters are flush with the top of the ridgeboard.

12. Toenail into the ridgeboard.

**NOTE ►** Make sure the plumb cut of the bird's mouth is snug to the outside of the top plate.

13. Toenail into top plate.

14. Erect the hip rafters using the following steps.

15. Stretch a string from the top of the hip to the bottom to help keep the hip line straight.

16. Erect the hip jack rafters.

**NOTE ►** Work from the longest to the shortest rafter.



**Yes**   **No**

- |                          |                          |  |
|--------------------------|--------------------------|--|
| <input type="checkbox"/> | <input type="checkbox"/> | 17. Nail through the jack rafter into the hip rafter at the cheek with 8d nails.                             |
| <input type="checkbox"/> | <input type="checkbox"/> | 18. Work both sides of the hip at the same time.   |
| <input type="checkbox"/> | <input type="checkbox"/> | 19. Erect remaining rafters.   |
| <input type="checkbox"/> | <input type="checkbox"/> | 20. When all the rafters have been erected install purlins.  |
| <input type="checkbox"/> | <input type="checkbox"/> | 21. Install strongbacks, rafter braces, and collar ties as required.   |
| <input type="checkbox"/> | <input type="checkbox"/> | 22. Trim the rafter tails.   |
| <input type="checkbox"/> | <input type="checkbox"/> | A. Mark the length of each end rafter at the determined length.  |
| <input type="checkbox"/> | <input type="checkbox"/> | B. Chalk a line on top of all rafters to locate the cutting line.  |
| <input type="checkbox"/> | <input type="checkbox"/> | C. Mark the side of each rafter with the framing square for a square end cut or plumb cut.                   |
| <input type="checkbox"/> | <input type="checkbox"/> | D. Build a platform or erect a scaffold and assume a comfortable and safe position before starting each cut. |
| <input type="checkbox"/> | <input type="checkbox"/> | E. Cut off the tails with a circular saw.  |
| <input type="checkbox"/> | <input type="checkbox"/> | 23. Nail sub (or false) fascia to the ends of all the rafters around the perimeter.                          |
| <input type="checkbox"/> | <input type="checkbox"/> | 24. Clean up area and put away equipment and supplies.   |

## PRODUCT EVALUATION

### SKILL TEST RECORD

**Evaluator note:** Rate the student on the following criteria by circling the appropriate numbers. Each criterion must receive a rating of “3” or higher to demonstrate student mastery. (See Key below.) A student who is unable to demonstrate mastery should review the material and submit another product for evaluation.

Criteria:

Observed safety procedures	4	3	2	1
Used proper equipment correctly	4	3	2	1
Performed steps in a timely manner	4	3	2	1
Followed instructions	4	3	2	1
Provided satisfactory responses to questions asked	4	3	2	1

## AVERAGE RATING

**Evaluator note:** To obtain an average rating for the Profile of Training Mastery, total the points in Product Evaluation and divide by the total number of criteria. Circle the rating on the Key.

## KEY

- 4 Skilled** — Can perform job with no additional training
- 3 Moderately Skilled** — Has performed job during training program; limited additional training may be required
- 2 Limited Skill** — Has performed job during training program; additional training is required to develop skill
- 1 Unskilled** — Is familiar with process, but is unable to perform job

## EVALUATOR'S COMMENTS

---

---

---

Student Name: \_\_\_\_\_ Score: \_\_\_\_\_

**LAY OUT, CUT, AND ERECT RAFTERS FOR AN INTERSECTING HIP ROOF WITH VALLEY.****BASIC SKILLS****INTRODUCTION**

This procedure describes the steps to layout, cut, and erect rafters for an intersecting hip roof with a valley. In the example given the slope of the common rafter is 5 in 12, uses 2x framing material, and the rafters are on 24" centers. Consult with your instructor should other measurements be desired.

**EQUIPMENT AND SUPPLIES**

- 8d and 16d box nails
- 100' tape
- Chalk line
- Circular saw and extension cord
- Framing hammer
- Framing square
- Handsaw
- Rafter table booklet
- Pencil
- Personal protective equipment
- Rafter materials
- Ridgeboard material
- Sawhorses (2)
- Steel tape
- String line

## PROCEDURE

This job sheet continues the construction of the structure with a gable roof by adding an intersecting hip roof with valley. The hip roof is highlighted in Figure 26.

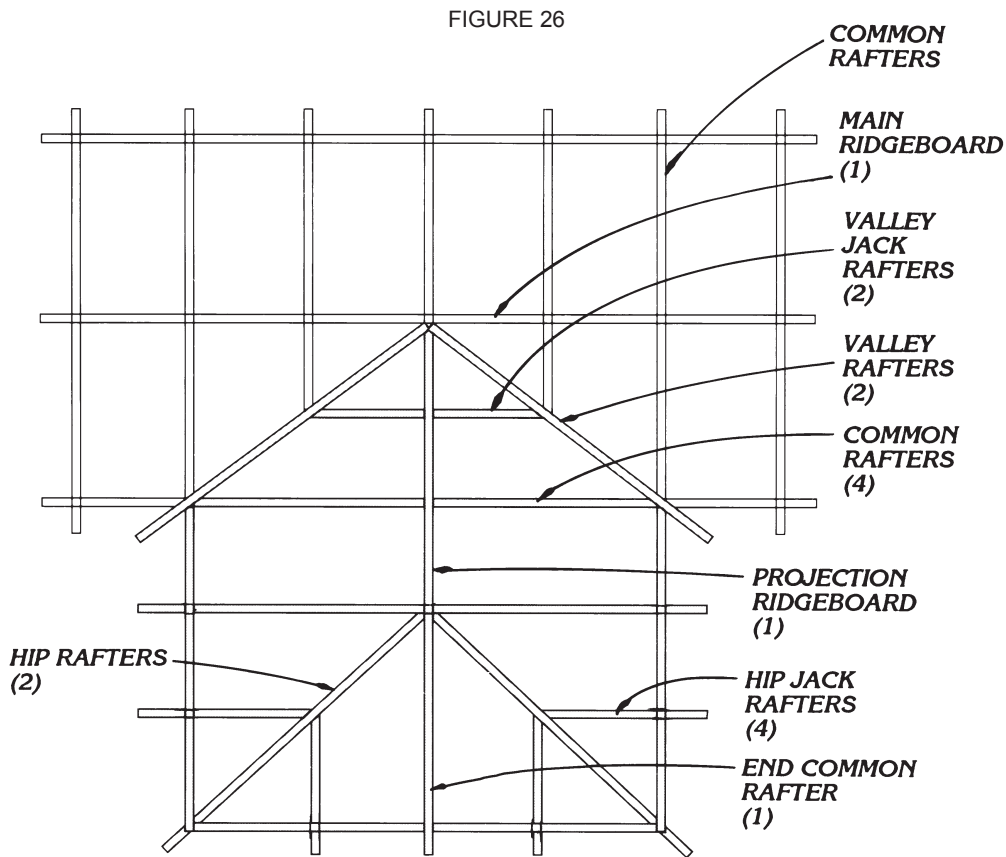

Yes No

1. Put on personal protective equipment.

2. Lay out top plate and ridge as shown in Figure 27.



FIGURE 27

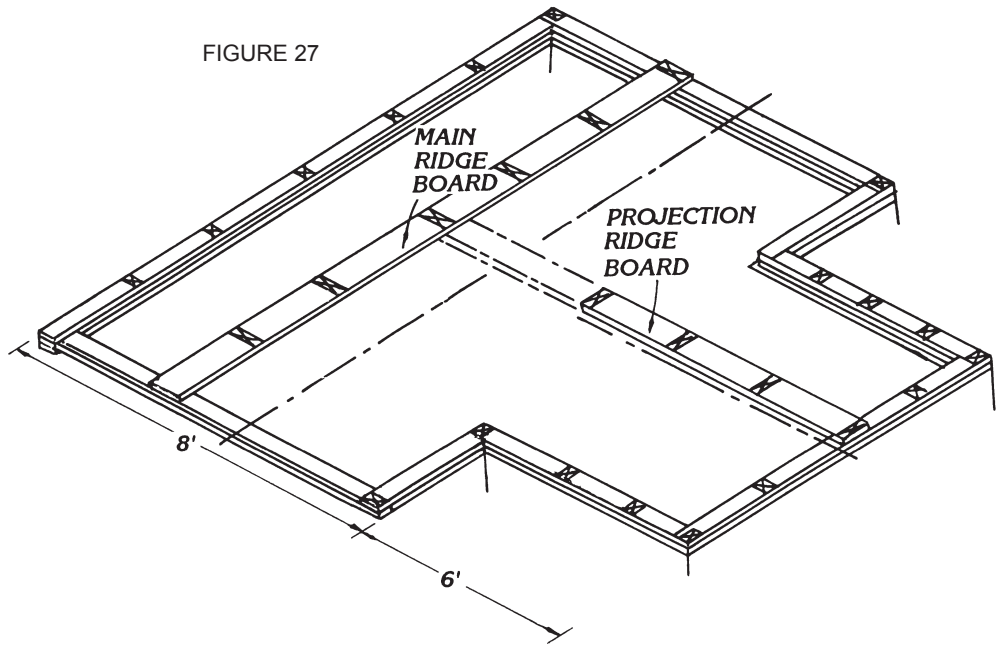

Yes No

- Lay out and cut the hip and valley rafters for the building projections.

**NOTE** ▶ The projection ridgeboard will intersect with the hip and valley rafters as shown in Figure 28.

FIGURE 28

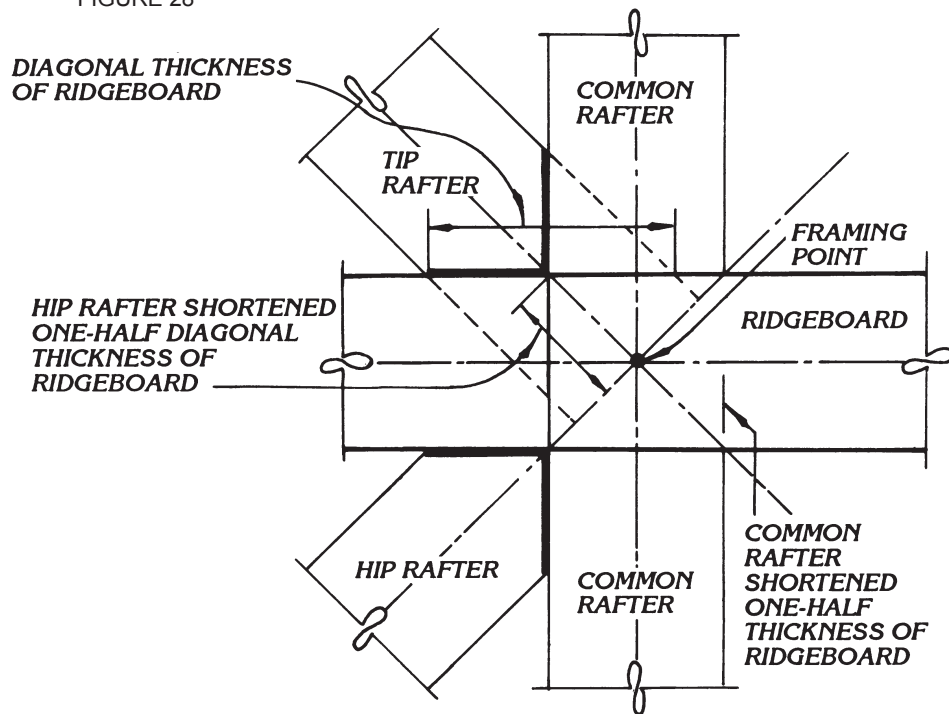



Yes No

A. Using Figure 29 and Table 2 at the end of this unit, calculate the length of the hip and valley rafters.

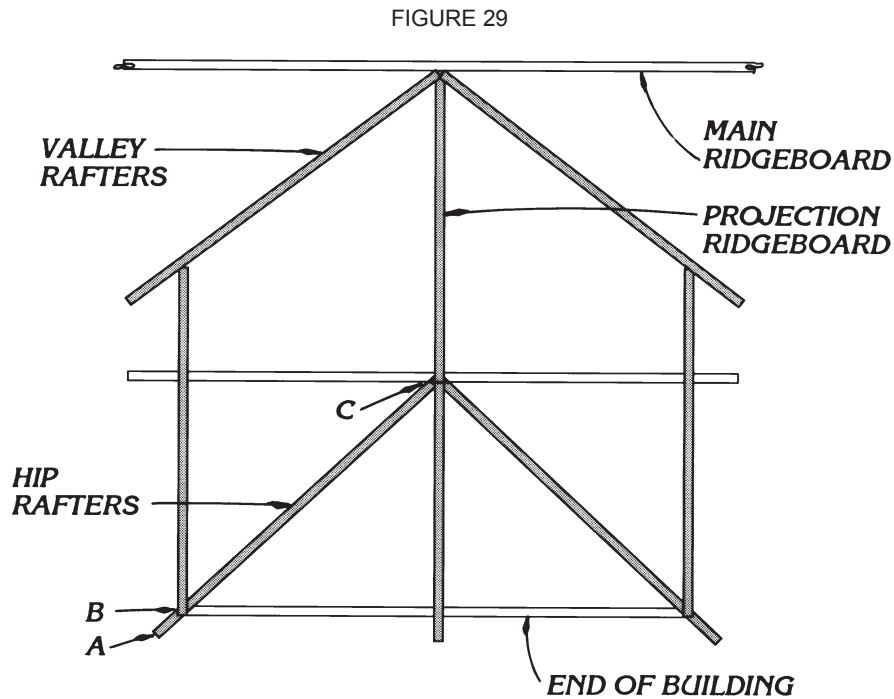

B. Using the hip and valley rafter lengths obtained from the table, subtract one-half the diagonal width of the projection ridgeboard and add the length of the rafter tail or overhang. Length of hip/valley rafter = A to C.

C. Cut one hip rafter with a bevel or cheek cuts and birds-mouth as shown in Figure 30. In comparison to a common rafter, lower the birds-mouth by  $\frac{3}{8}$ " ( $A + \frac{3}{8}$ ").

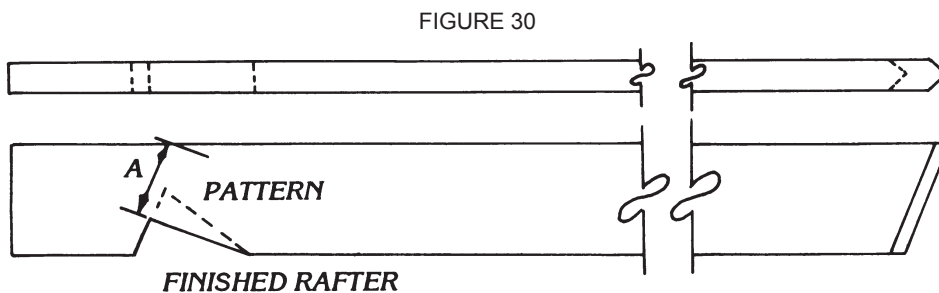



Yes No

D. Double check your layout and if correct, use the finished rafter as a pattern for the second rafter.

E. Cut two valley rafters with the bird's mouth cut raised by  $\frac{3}{8}$ " (A -  $\frac{3}{8}$ ") in comparison to a common rafter.

4. Lay out and cut the projection ridgeboard.

A. The ridgeboard length is equal to the total length of the building extension plus one-half the width of the main gabled structure minus one-half the width of the building extension.

**EXAMPLE:** ► For an 8' x 12' structure, the projection ridgeboard is equal to  $6' + 4' - 4' = 6'$ .

B. Using a framing square, mark and square cut the projection ridgeboard.

5. Lay out and cut jack rafters on 24" centers.

A. Measure length of first jack rafter from the plumb of the bird's mouth.

**NOTE** ► Remember that the figure read from the framing square is the difference in length of jack rafters from the common rafter.

B. Use pattern for common rafters to mark bird's mouth.

**NOTE** ► Drop the hip  $\frac{3}{8}$ " to align with common rafter and raise  $\frac{3}{8}$ " on valley rafters for  $\frac{1}{2}$ " material.

C. Measure length of first jack rafter from plumb cut of bird's mouth.

**NOTE** ► Remember that this length is the theoretical length of the jack rafter and it must be shortened one-half the diagonal thickness of the hip rafter.

FIGURE 31

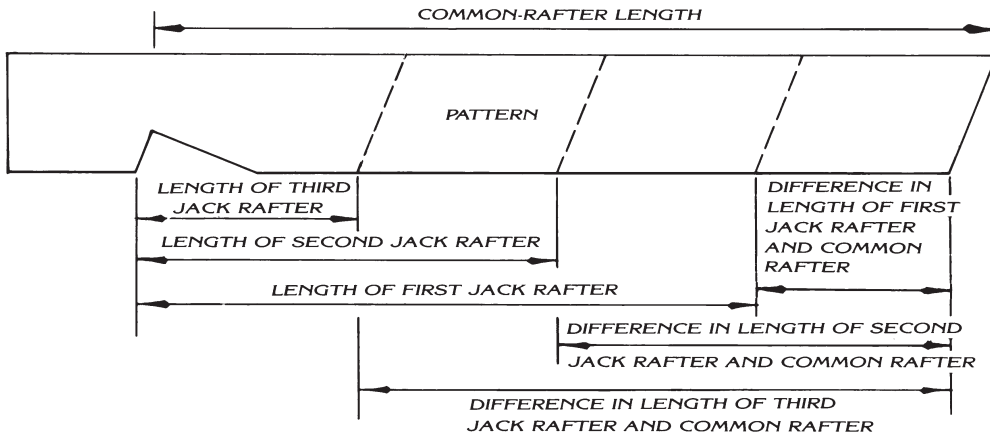
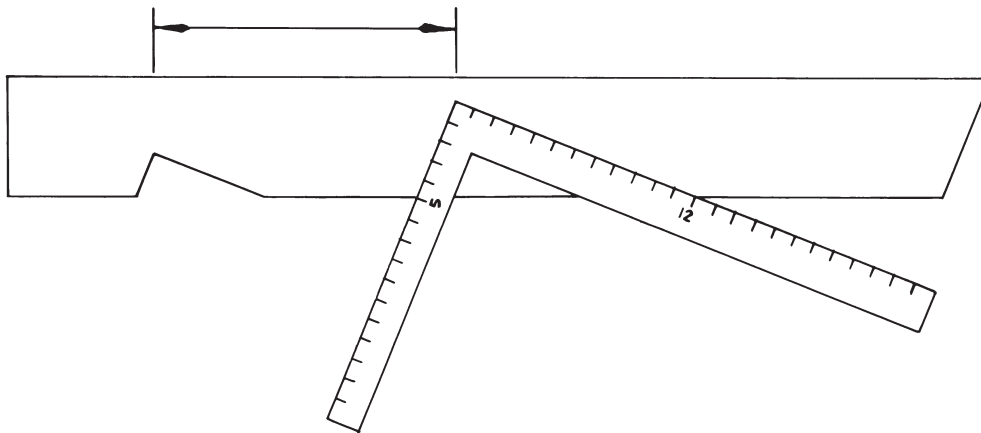

FIGURE 32



Yes No

D. Shorten rafter and bevel as required.



FIGURE 33

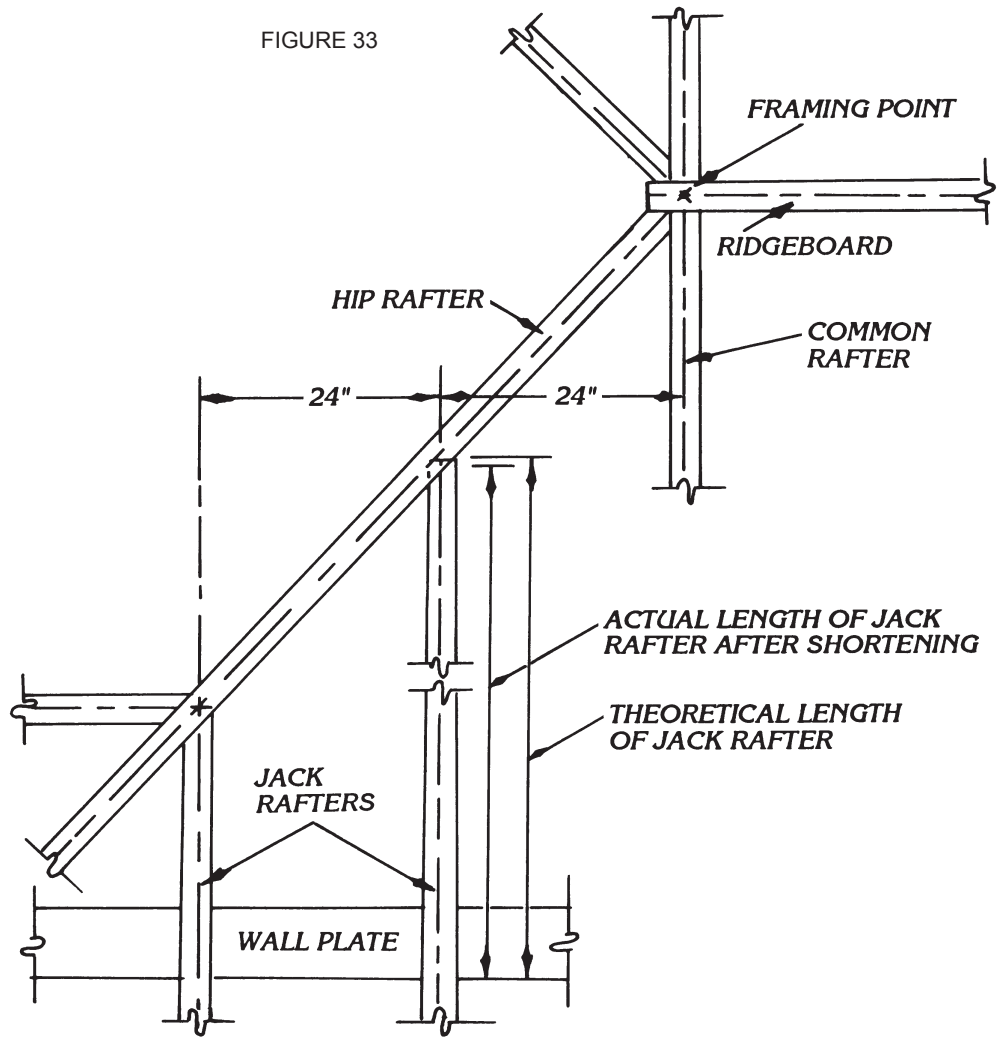

Yes No

6. Lay out and cut all jack rafters (2 for hip, 2 for valley).

**NOTE** ▶ For every jack rafter with a cheek cut on the left, there must be one of equal length with a cheek cut on the right.

7. Lay out and cut all end common rafters (3 each) with cheek cuts.

8. Lay out and cut common rafters for building projection (4 each). Two common rafters should be cut with an overhang considered.

FIGURE 34

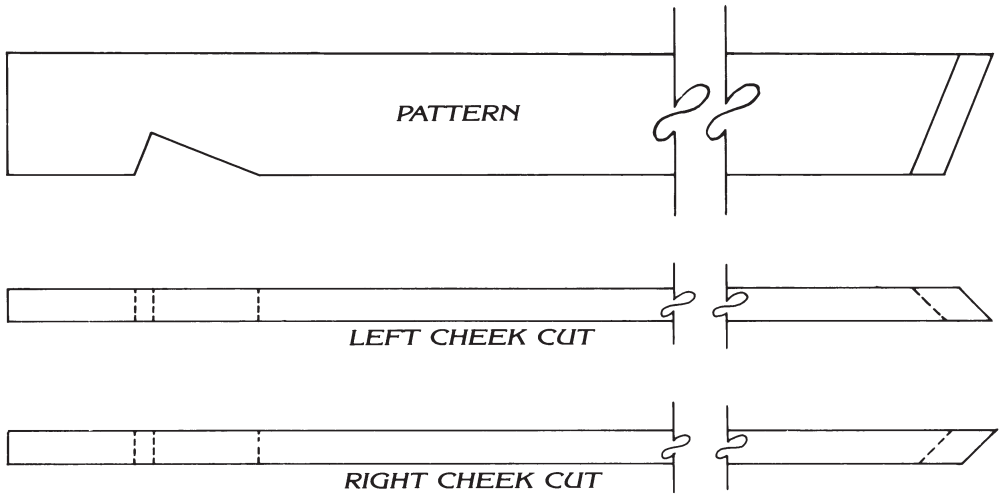

**CAUTION:** Place boards across ceiling joists to walk on.

Yes No

A. Lean all rafters against sides of structure at each rafter location mark, with ridgeboard plumb cut up.

B. Erect common rafters with ridgeboard as shown in Figure 35.

FIGURE 35

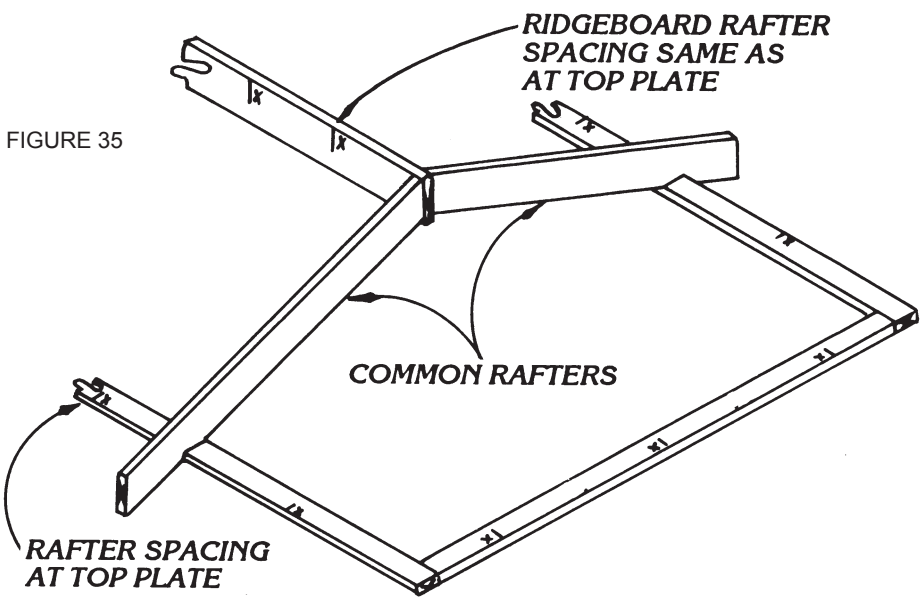



Yes No

C. Nail through ridgeboard into end of rafters with 16d box nails.

**NOTE** ▶ Be sure that tops of all rafters are flush with top of ridgeboard.

D. Toenail seat of bird's mouth cut to top plate with 16d box nails.

**NOTE** ▶ Be sure that the plumb cut of the bird's mouth is snugged up to the outside of the top plate.

9. Use straightline to keep ridgeboard straight.

10. Erect end common rafters, toenailing into ridgeboard and into top plate. See Figure 36.

**NOTE** ▶ Be sure that the top of the rafters are flush with the top of the ridgeboard and that the plumb cut of the bird's mouth is snug to the outside of the top plate.

11. Erect hip rafters.

FIGURE 36

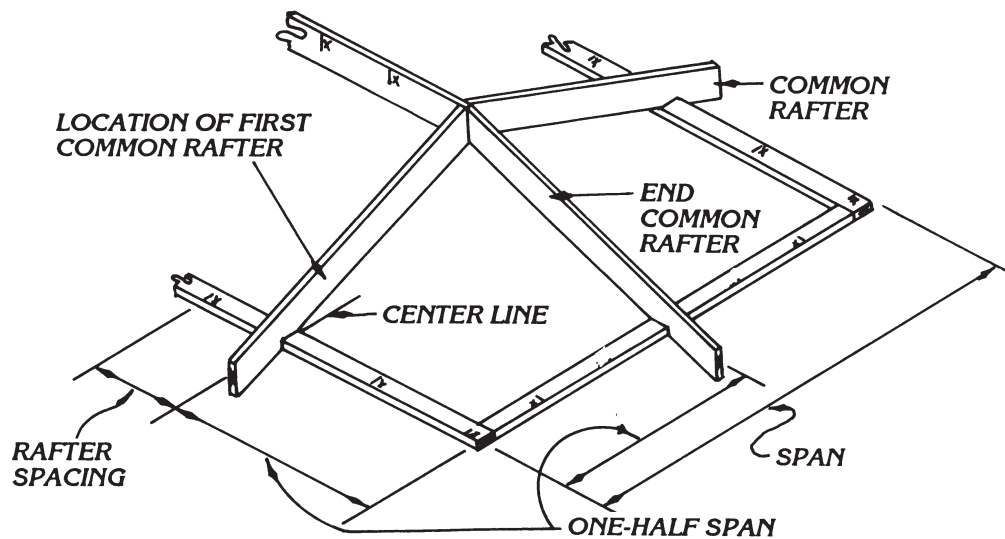
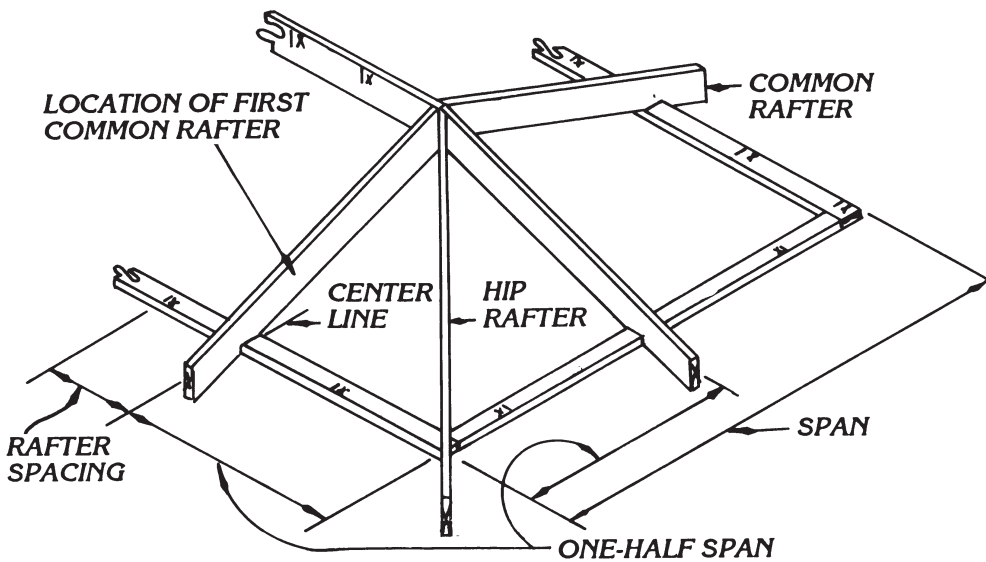

FIGURE 37



Yes No

12. Erect hip jack rafters.
- A. Proceed from longest to shortest rafter.
- B. Work both sides of hip at same time.

**NOTE** ▶ Nail through the jack rafter into the hip rafter at the cheek with 8d box nails. Be sure to keep the top of the hip in a straight line from top to bottom.

FIGURE 38

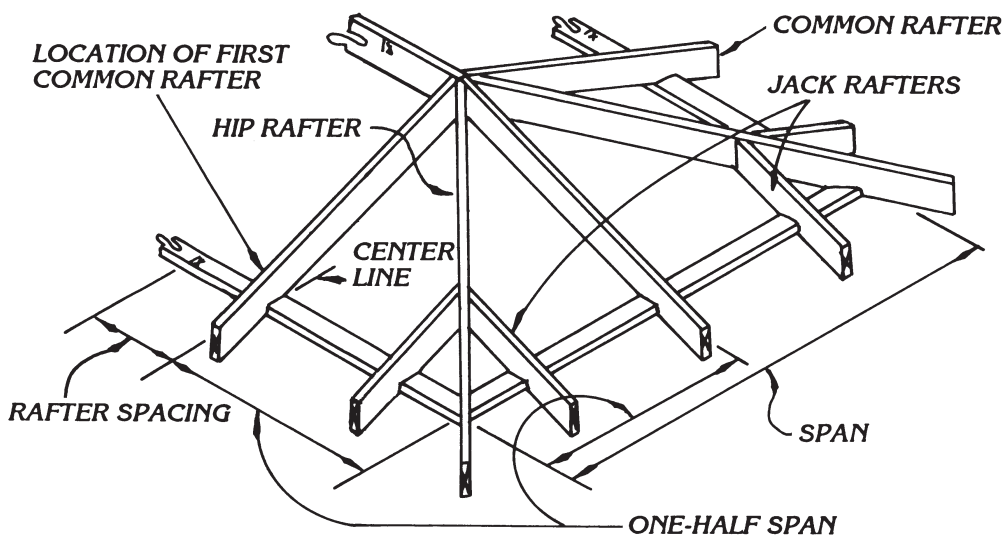



Yes No

C. Stretch a string from top of the hip to the bottom to aid in keeping the hip line straight.

13. Erect remaining rafters.

14. Install purlins, strongbacks, and collar beams as required.

FIGURE 39

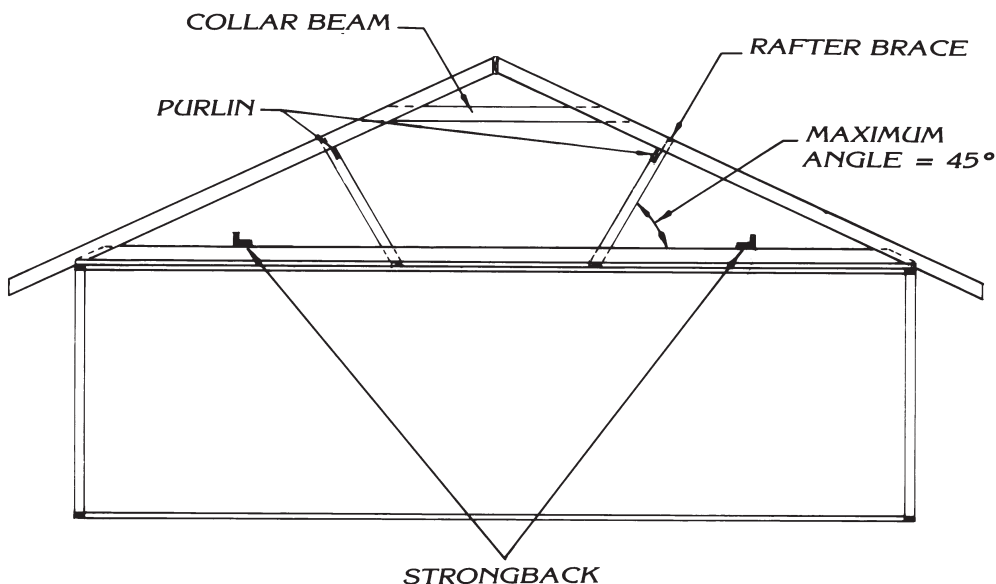

15. Trim rafter tails.

A. Mark length of each end rafter at determined length.

B. Chalk a line on top of all rafters to locate cutting line.

C. Mark side of each rafter with framing square for a square end cut.

D. Cut off tails with circular saw.

**CAUTION:** Erect a platform to use while cutting, and assume a comfortable and safe position before starting each cut.

16. Nail false fascia to ends of all rafters around structure's perimeter, allowing ends on roof to extend far enough for barge rafter. See Figure 40.



FIGURE 40

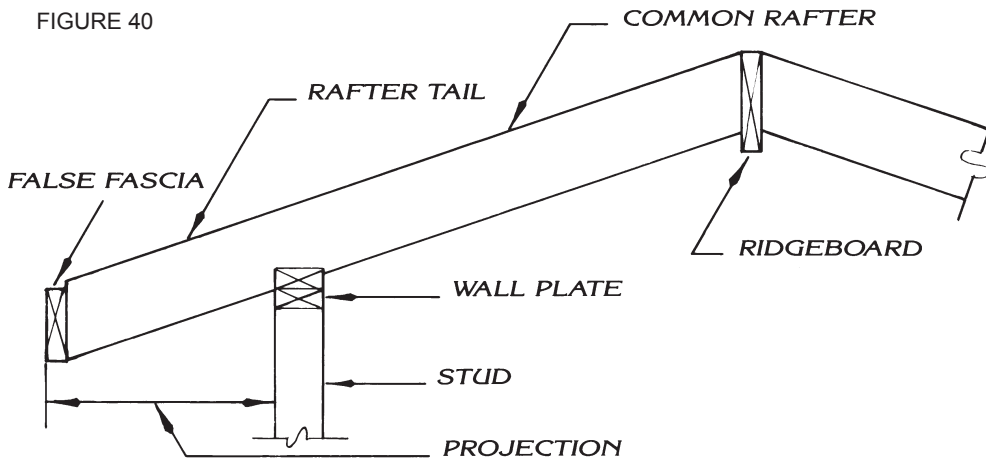

Yes No



17. Clean up area and put away equipment and supplies.

## PRODUCT EVALUATION

### SKILL TEST RECORD

**Evaluator note:** Rate the student on the following criteria by circling the appropriate numbers. Each criterion must receive a rating of “3” or higher to demonstrate student mastery. (See Key below.) A student who is unable to demonstrate mastery should review the material and submit another product for evaluation.

Criteria:

Observed safety procedures	4	3	2	1
Used proper equipment correctly	4	3	2	1
Performed steps in a timely manner	4	3	2	1
Followed instructions	4	3	2	1
Provided satisfactory responses to questions asked	4	3	2	1

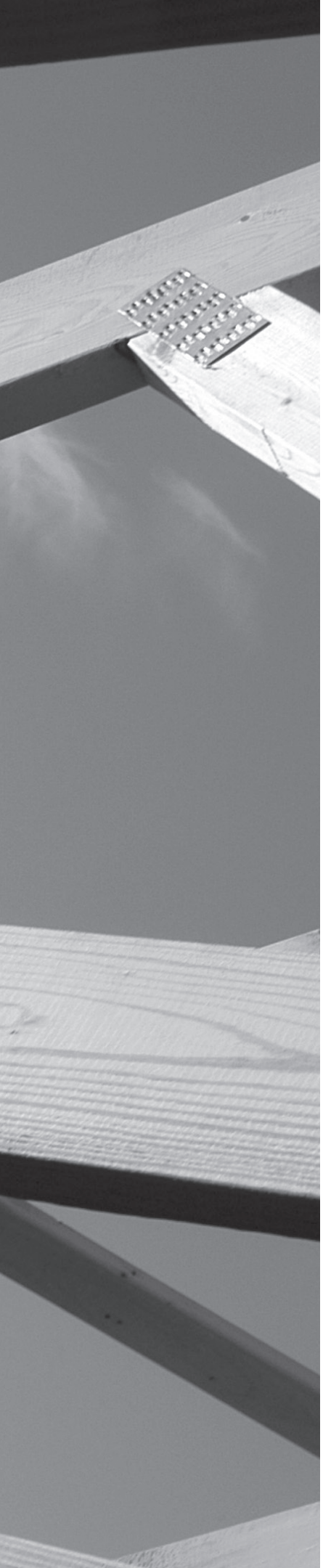

## AVERAGE RATING

**Evaluator note:** To obtain an average rating for the Profile of Training Mastery, total the points in Product Evaluation and divide by the total number of criteria. Circle the rating on the Key.

## KEY

- 4 Skilled** — Can perform job with no additional training
- 3 Moderately Skilled** — Has performed job during training program; limited additional training may be required
- 2 Limited Skill** — Has performed job during training program; additional training is required to develop skill
- 1 Unskilled** — Is familiar with process, but is unable to perform job

## EVALUATOR'S COMMENTS

---

---

---



Student Name: \_\_\_\_\_ Score: \_\_\_\_\_

**FRAME AN OPENING IN A ROOF.**

**BASIC SKILLS**



**INTRODUCTION**

You may need to frame an opening in a roof for a skylight, chimney, or other application.

**EQUIPMENT AND SUPPLIES**

- 100' tape
- 16d and 8d nails
- Circular saw
- Claw hammer
- Framing square
- Hand level
- Joist and header material
- Pencil
- Personal protective equipment
- Plans (furnished by instructor)
- Plumb bob and line
- Steel tape

## PROCEDURE

Yes No

- |                          |                          |   |
|--------------------------|--------------------------|---|
| <input type="checkbox"/> | <input type="checkbox"/> | 1. Put on personal protective equipment.  |
| <input type="checkbox"/> | <input type="checkbox"/> | 2. Check your plans to establish the position and size of the opening.  |
| <input type="checkbox"/> | <input type="checkbox"/> | 3. Lay out the opening on the floor.<br><b>NOTE</b> ► Remember to provide clearance as required for chimney.  |
| <input type="checkbox"/> | <input type="checkbox"/> | 4. Use a plumb bob to transfer the layout to the rafters. Mark the plumb lines using a framing square or level.   |
| <input type="checkbox"/> | <input type="checkbox"/> | 5. Nail a temporary brace across the top of the rafters to be cut.<br><b>NOTE</b> ► This brace will hold the rafters in place until the headers are installed.          |
| <input type="checkbox"/> | <input type="checkbox"/> | 6. Measure the headers.   |
| <input type="checkbox"/> | <input type="checkbox"/> | 7. Cut the headers to size, following safety precautions.   |
| <input type="checkbox"/> | <input type="checkbox"/> | 8. Cut the rafter, allowing for appropriate clearance and for double headers, if they are required.<br><b>NOTE</b> ► Double headers should be used if opening is large. |
| <input type="checkbox"/> | <input type="checkbox"/> | 9. Install additional rafters as required.  |
| <input type="checkbox"/> | <input type="checkbox"/> | 10. Nail the headers in place.  |
| <input type="checkbox"/> | <input type="checkbox"/> | 11. Add a double trimmer rafter to both sides of opening. See Figure 41.  |
| <input type="checkbox"/> | <input type="checkbox"/> | 12. Clean up area and put away equipment and supplies.  |



FIGURE 41

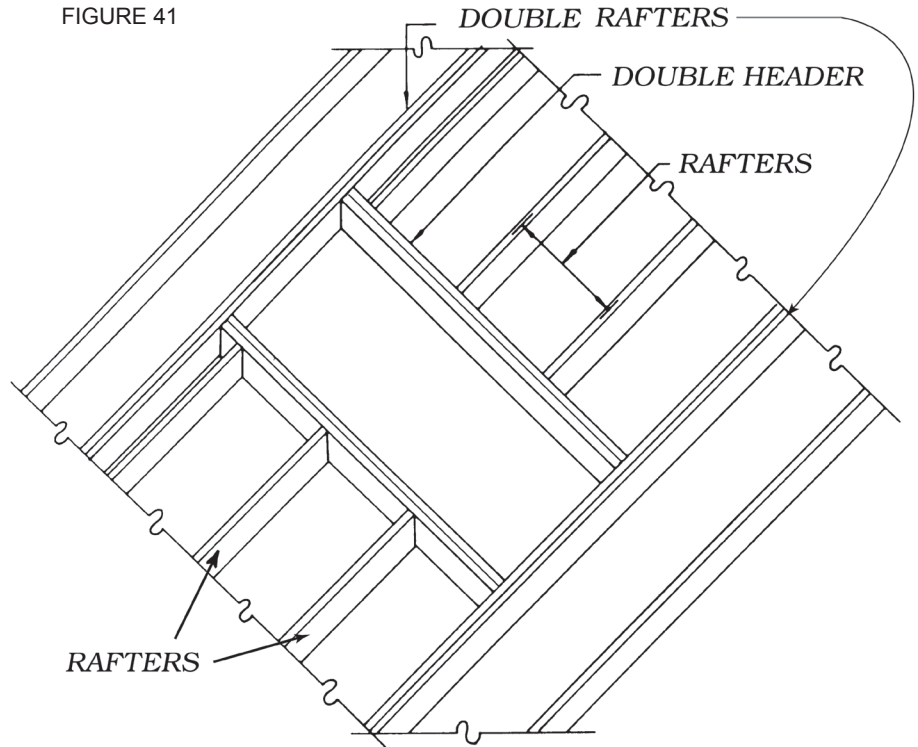

## PRODUCT EVALUATION

### SKILL TEST RECORD

**Evaluator note:** Rate the student on the following criteria by circling the appropriate numbers. Each criterion must receive a rating of “3” or higher to demonstrate student mastery. (See Key below.) A student who is unable to demonstrate mastery should review the material and submit another product for evaluation.

Criteria:

Observed safety procedures	4	3	2	1
Used proper equipment correctly	4	3	2	1
Performed steps in a timely manner	4	3	2	1
Followed instructions	4	3	2	1
Provided satisfactory responses to questions asked	4	3	2	1

## AVERAGE RATING

**Evaluator note:** To obtain an average rating for the Profile of Training Mastery, total the points in Product Evaluation and divide by the total number of criteria. Circle the rating on the Key.

## KEY

- 4 Skilled** — Can perform job with no additional training
- 3 Moderately Skilled** — Has performed job during training program; limited additional training may be required
- 2 Limited Skill** — Has performed job during training program; additional training is required to develop skill
- 1 Unskilled** — Is familiar with process, but is unable to perform job

## EVALUATOR'S COMMENTS

---

---

---

Student Name: \_\_\_\_\_ Score: \_\_\_\_\_

**APPLY ROOF SHEATHING.**

**BASIC SKILLS**



**INTRODUCTION**

Roof sheathing provides a base for the roofing material as well as providing strength to the roof framing. Plywood is the most common sheathing material, but lumber or laminated decking is also used.

**EQUIPMENT AND SUPPLIES**

- Chalk line
- Circular saw
- Framing square
- Framing hammer
- Nails specified for sheathing
- Pencil
- Personal protective equipment
- Plans (furnished by instructor)
- Steel tape
- Toe boards



## PROCEDURE

Yes No

- |                          |                          |   |
|--------------------------|--------------------------|---|
| <input type="checkbox"/> | <input type="checkbox"/> | 1. Put on all the appropriate personal protective equipment.                                  |
| <input type="checkbox"/> | <input type="checkbox"/> | 2. Check the plans for special installation requirements.                                     |
| <input type="checkbox"/> | <input type="checkbox"/> | 3. Measure and mark 48¼" up from where the finish fascia will be installed. See Figure 42.    |
| <input type="checkbox"/> | <input type="checkbox"/> | 4. Chalk a line at the marks across the rafters or trusses.                                   |
| <input type="checkbox"/> | <input type="checkbox"/> | 5. Install bottom row of sheathing. See Figure 43.  |
|                          |                          | <b>NOTE</b> ▶ Be sure to check that all rafters or trusses are on proper centers.             |
| <input type="checkbox"/> | <input type="checkbox"/> | 6. Apply toe board where pitch requires and use a safety harness.                             |
| <input type="checkbox"/> | <input type="checkbox"/> | 7. Stagger plywood joints by starting the second row with a half sheet.                       |
|                          |                          | <b>NOTE</b> ▶ Install plywood clips before applying the second row of sheathing, if required. |

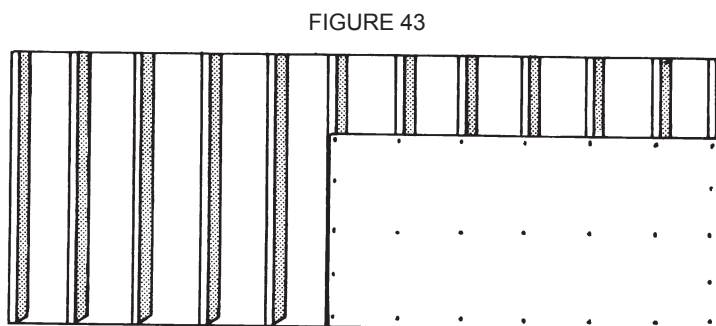
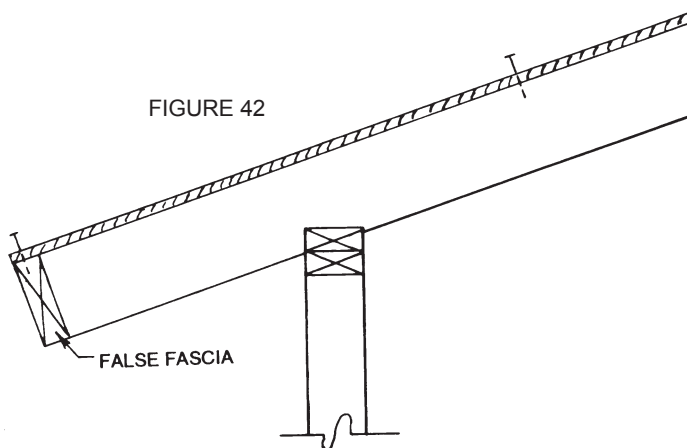



Yes No

8. Install remaining sheets on the roof.
- A. Check rafter or truss layout.
- B. Nail the top of each row.
- C. Allow sheathing to extend over the hip and ridge of the roof as well as the gable end.

**NOTE** ► Do not stand or walk on the extended sheathing. Sheathing should extend over the hip rafter if a hip roof is being installed.

9. After all the sheathing is nailed, chalk a line at the edge of the roof on the extended sheathing.

10. Cut the extended sheathing off with a circular saw, following safety precautions.

**NOTE** ► Sawdust can make footing very dangerous.

11. Finish nailing all the sheathing and install the fasteners according to the manufacturer's instructions. See Figure 44.

12. Clean up area and put away equipment and supplies.

FIGURE 44

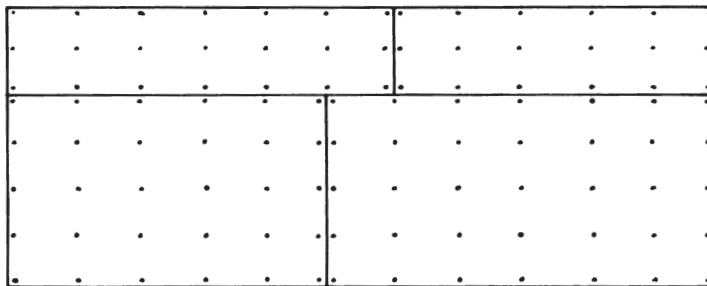

## PRODUCT EVALUATION

### SKILL TEST RECORD

**Evaluator note:** Rate the student on the following criteria by circling the appropriate numbers. Each criterion must receive a rating of “3” or higher to demonstrate student mastery. (See Key below.) A student who is unable to demonstrate mastery should review the material and submit another product for evaluation.

Criteria:

Observed safety procedures	4	3	2	1
Used proper equipment correctly	4	3	2	1
Performed steps in a timely manner	4	3	2	1
Followed instructions	4	3	2	1
Provided satisfactory responses to questions asked	4	3	2	1

## AVERAGE RATING

**Evaluator note:** To obtain an average rating for the Profile of Training Mastery, total the points in Product Evaluation and divide by the total number of criteria. Circle the rating on the Key.

## KEY

- 4 Skilled** — Can perform job with no additional training
- 3 Moderately Skilled** — Has performed job during training program; limited additional training may be required
- 2 Limited Skill** — Has performed job during training program; additional training is required to develop skill
- 1 Unskilled** — Is familiar with process, but is unable to perform job

## EVALUATOR'S COMMENTS

---

---

---

# TABLE 1

**JACK RAFTER**

Spaced In.	Length Ft. In.
1..	1
2..	2 1/8
3..	3 1/8
4..	4 1/4
5..	5 1/4
6..	6 3/8
7..	7 3/8
8..	8 3/8
9..	9 1/2
10..	10 1/2
11..	11 5/8
12..	11 5/8
13..	1 3/4
14..	2 3/4
15..	3 3/4
16..	4 7/8
17..	5 7/8
18..	7
19..	8
20..	9 1/8
21..	10 1/8
22..	11 1/4
23..	11 1/4
24..	1 1/4
25..	2 3/8
26..	3 3/8
27..	4 1/2
28..	5 1/2
29..	6 5/8
30..	7 5/8
31..	8 5/8
32..	9 3/4
33..	10 3/4
34..	11 7/8
35..	11 7/8
36..	2
37..	3
38..	4
39..	5 1/8
40..	6 1/8
41..	7 1/4
42..	8 1/4
43..	9 3/8
44..	10 3/8
45..	11 3/8
46..	11 3/8
47..	1 1/2
48..	2 5/8

## 4-INCH RISE PER FOOT

### EXPLANATION

**Common Rafter**  
Width of building.....31'4 3/4"  
Find length of Common Rafter.

**Answer:**  
Under Span, ft. find 31' = 16' 4"  
" " in. " 4 3/4" = 2 1/2"

Total length Common Rft. 16' 6 1/2"

**When rafters overhang**, add both overhangs to width of building. Use total span as before.

**To get length of rafter by its run:** doubling the run gives the span. Proceed as before.

Tables give full length. Allow for half thickness of ridge.

Spans over 50', as 60', add lengths of 50' & 10' spans together.

#### Hip Rafter

If common rafter span is 31'4 3/4", Hip rafter is 22'9 3/4" long. Measure length of Hip on center of top edge. If Hip is unbacked (top edge square), see Index. If edge is backed (beveled), see Index.

Allow for half thickness of ridge.

#### Jack Rafters

Spaced 28" apart are 2'5 1/2" different in length. Measure length on center of top edge. Cut short equal to half thickness of hip.

#### CUTS FOR STEEL SQUARE.

The first figure is always the cut.

<b>Common Rafter</b>	<b>Purlin Rafter</b>
Plumb 4 - 12	<b>Roof Sheathing</b>
Level. 12 4	Plumb 4 - 12 5/8
	Cross. 12 - 12 5/8

<b>Hip Rafter</b>	<b>Valley Shingles</b>
Plumb 4 - 17	Cross. 12 - 12 5/8
Level. 17 - 4	Set bevel on
Side.. 8 3/4 - 8 1/2	butt end. "
Backing 4 - 17 3/8	

Set bevel to last named.

<b>Jack Rafter</b>	<b>Mitre-Box Cuts</b>
Plumb 4 - 12	<b>for Gable Moulds</b>
Level. 12 4	Plumb 4 - 12
Side.. 12 5/8 - 12	Mitre. 12 5/8 - 12

**Bisection of**  
4- 12=3 7/8- 24

For full explanation see Index.

**COMMON RAFTER**

Span Ft.	Length Ft. In.	Span In.	Lgth. In.
1..	6 3/8	1/4..	1/8
2..	1. 0 5/8	1/2..	1/4
3..	1. 7	3/4..	3/8
4..	2. 1 1/4	1 ..	1/2
5..	2. 7 5/8	1 1/4..	5/8
6..	3. 2	1 1/2..	3/4
7..	3. 8 1/4	3/4..	7/8
8..	4. 2 5/8	2 ..	1
9..	4. 8 7/8	1 1/4..	1/8
10..	5. 3 1/4	1 1/2..	3/8
11..	5. 9 5/8	3/4..	1/2
12..	6. 3 7/8	3 ..	5/8
13..	6. 10 1/4	1 1/4..	3/4
14..	7. 4 1/2	1 1/2..	7/8
15..	7. 10 7/8	3/4..	2
16..	8. 5 1/4	4 ..	1 1/8
17..	8. 11 1/2	1 1/4..	1/4
18..	9. 5 7/8	1 1/2..	3/8
19..	10. 0 1/8	3/4..	1/2
20..	10. 6 1/2	5 ..	5/8
21..	11. 0 7/8	1 1/4..	3/4
22..	11. 7 1/8	1 1/2..	7/8
23..	12. 1 1/2	3/4..	3
24..	12. 7 3/4	6 ..	1 1/8
25..	13. 2 1/8	1 1/4..	1/4
26..	13. 8 1/2	1 1/2..	3/8
27..	14. 2 3/4	3/4..	1/2
28..	14. 9 1/8	7 ..	3/4
29..	15. 3 3/8	1 1/4..	7/8
30..	15. 9 3/4	1 1/2..	4
31..	16. 4	3/4..	1 1/8
32..	16. 10 3/8	8 ..	1/4
33..	17. 4 3/4	1 1/4..	3/8
34..	17. 11	1 1/2..	1/2
35..	18. 5 3/8	3/4..	5/8
36..	18. 11 5/8	9 ..	3/4
37..	19. 6	1 1/4..	7/8
38..	20. 0 3/8	1 1/2..	5
39..	20. 6 5/8	3/4..	1 1/8
40..	21. 1	10 ..	1/4
41..	21. 7 1/4	1 1/4..	3/8
42..	22. 1 5/8	1 1/2..	1/2
43..	22. 8	3/4..	5/8
44..	23. 2 1/4	11 ..	3/4
45..	23. 8 5/8	1 1/4..	7/8
46..	24. 3	1 1/2..	6
47..	24. 9 1/4	3/4..	1 1/4
48..	25. 3 3/8	12 ..	3/8
49..	25. 9 7/8		
50..	26. 4 1/4		

**HIP OR VALLEY RAFTER**

Span Ft.	Length Ft. In.	Span In.	Lgth. In.
1..	8 3/4	1/4..	1/8
2..	1. 5 3/8	1/2..	3/8
3..	2. 2 1/8	3/4..	1/2
4..	2. 10 7/8	1 ..	3/4
5..	3. 7 5/8	1 1/4..	7/8
6..	4. 4 1/4	1 1/2..	1 1/8
7..	5. 1	3/4..	1 1/4
8..	5. 9 3/4	2 ..	1/2
9..	6. 6 1/2	1 1/4..	5/8
10..	7. 3 1/8	1 1/2..	7/8
11..	7. 11 7/8	3/4..	2
12..	8. 8 5/8	3 ..	1 1/8
13..	9. 5 3/8	1 1/4..	3/8
14..	10. 2	1 1/2..	1/2
15..	10. 10 3/4	3/4..	3/4
16..	11. 7 1/2	4 ..	7/8
17..	12. 4 1/4	1 1/4..	3 1/8
18..	13. 0 7/8	1 1/2..	1/4
19..	13. 9 5/8	3/4..	1 1/2
20..	14. 6 3/8	5 ..	5/8
21..	15. 3 1/8	1 1/4..	7/8
22..	15. 11 3/4	1 1/2..	4
23..	16. 8 1/2	3/4..	1 1/8
24..	17. 5 1/4	6 ..	3/8
25..	18. 2	1 1/4..	1/2
26..	18. 10 5/8	1 1/2..	3/4
27..	19. 7 3/8	3/4..	7/8
28..	20. 4 1/8	7 ..	5 1/8
29..	21. 0 7/8	1 1/4..	1/4
30..	21. 9 1/2	1 1/2..	1/2
31..	22. 6 1/4	3/4..	5/8
32..	23. 3	8 ..	3/4
33..	23. 11 3/4	1 1/4..	6
34..	24. 8 3/8	1 1/2..	1 1/8
35..	25. 5 1/8	3/4..	3 1/8
36..	26. 1 7/8	9 ..	1/2
37..	26. 10 1/2	1 1/4..	3/4
38..	27. 7 1/4	1 1/2..	7/8
39..	28. 4	3/4..	7 1/8
40..	29. 0 3/4	10 ..	1/4
41..	29. 9 3/8	1 1/4..	1/2
42..	30. 6 1/8	1 1/2..	5/8
43..	31. 2 7/8	3/4..	3/4
44..	31. 11 5/8	11 ..	8
45..	32. 8 1/4	1 1/4..	1 1/8
46..	33. 5	1 1/2..	3/8
47..	34. 1 3/4	3/4..	1/2
48..	34. 10 1/2	12 ..	3/4
49..	35. 7 1/8		
50..	36. 3 7/8		

# TABLE 2

**ACK RAFTER**

paced In.	Length Ft. In.
1..	1 1/8
2..	2 1/4
3..	3 3/8
4..	4 1/2
5..	5 5/8
6..	6 3/4
7..	7 7/8
8..	9
9..	10 1/8
10..	11 1/8
11.. I	0 1/4
12..	1 3/8
13..	2 1/2
14..	3 5/8
15..	4 3/4
16..	5 7/8
17..	7
18..	8 1/8
19..	9 1/4
20..	10 3/8
21..	11 1/2
22.. 2..	0 5/8
23..	1 3/4
24..	2 7/8
25..	4
26..	5 1/8
27..	6 1/8
28..	7 1/4
29..	8 3/8
30..	9 1/2
31..	10 5/8
32..	11 3/4
33.. 3..	0 7/8
34..	2
35..	3 1/8
36..	4 1/4
37..	5 3/8
38..	6 1/2
39..	7 5/8
40..	8 3/4
41..	9 7/8
42..	11
43.. 4..	0 1/8
44..	1 1/4
45..	2 1/4
46..	3 3/8
47..	4 1/2
48..	5 5/8

## 6-INCH RISE PER FOOT

### EXPLANATION

#### Common Rafter

Width of building.....24'6 1/4"  
Find length of Common Rafter.

**Answer:**

Under Span, ft. find 24' = 13' 5"  
" " in. " 6 1/4" = 3 1/2"

Total length Common Rft. 13' 8 1/2"

**When rafters overhang, add both overhangs to width of building. Use total span as before.**

**To get length of rafter by its run:** doubling the run gives the span. Proceed as before.

Tables give full length. Allow for half thickness of ridge.

Spans over 50', as 60', add lengths of 50' & 10' spans together.

#### Hip Rafter

If common rafter span is 24'6 1/4", Hip rafter is 18'4 5/8" long. Measure length of Hip on center of top edge. If Hip is unbacked (top edge square), see Index. If edge is backed (beveled), see Index.

Allow for half thickness of ridge.

#### Jack Rafters

Spaced 24" apart are 2'2 7/8" different in length. Measure length on center of top edge. Cut snort equal to half thickness of hip.

#### CUTS FOR STEEL SQUARE.

The first figure is always the cut.

Common Rafter		Purlin Rafter	
Plumb	6 - 12	Roof Sheathing	
Level.	12 - 6	Plumb	6 - 13 3/8
		Cross.	12 - 13 3/8
Hip Rafter		Valley Shingles	
Plumb	6 - 17	Cross.	12 - 13 3/8
Level.	17 - 6	Set bevel on	
Side..	9 - 8 1/2	butt end.	
Backing	6 - 18	Mitre-Box Cuts	
Set bevel to		for Gable Moulds	
last named.		Plumb	6 - 12
Jack Rafter		Mitre.	13 3/8 - 12
Plumb	6 - 12	Bisection of	
Level.	12 - 6	6 - 12 = 5 3/8 - 24	
Side..	13 3/8 - 12		

For full explanation see Index.

**COMMON RAFTER**

Span Ft.	Length Ft. In.	Span In.	Lgth. In.
1..	6 3/4	1/4..	1/8
2..	1. 1 3/8	1/2..	1/4
3..	1. 8 1/8	3/4..	3/8
4..	2. 2 7/8	1..	1/2
5..	2. 9 1/2	1 1/4..	3/4
6..	3. 4 1/4	1 1/2..	7/8
7..	3. II	3/4..	I
8..	4. 5 5/8	2..	1 1/8
9..	5. 0 3/8	1/4..	1/4
10..	5. 7 1/8	1/2..	3/8
11..	6. 1 3/4	3/4..	1/2
12..	6. 8 1/2	1..	5/8
13..	7. 3 1/4	1 1/4..	7/8
14..	7. 9 7/8	1 1/2..	2
15..	8. 4 5/8	3/4..	1 1/8
16..	8. II 3/8	4..	1 1/4
17..	9. 6	1/4..	3/8
18..	10. 0 3/4	1/2..	1/2
19..	10. 7 1/2	3/4..	5/8
20..	11. 2 1/8	5..	1 3/4
21..	11. 8 7/8	1/4..	7/8
22..	12. 3 5/8	1/2..	3 1/8
23..	12. 10 1/4	3/4..	1 1/4
24..	13. 5	6..	1 3/8
25..	13. II 3/4	1/4..	1 1/2
26..	14. 6 3/8	1/2..	5/8
27..	15. 1 1/8	3/4..	3/4
28..	15. 7 7/8	7..	1 7/8
29..	16. 2 1/2	1/4..	4
30..	16. 9 1/4	1/2..	1 1/4
31..	17. 4	3/4..	3 3/8
32..	17. 10 5/8	8..	1 1/2
33..	18. 5 3/8	1/4..	5/8
34..	19. 0 1/8	1/2..	3/4
35..	19. 6 3/4	3/4..	7/8
36..	20. 1 1/2	9..	1 5/8
37..	20. 8 1/4	1/4..	1 1/8
38..	21. 2 7/8	1/2..	1 1/4
39..	21. 9 5/8	3/4..	1 1/2
40..	22. 4 3/8	10..	1 5/8
41..	22. II	1/4..	3/4
42..	23. 5 3/4	1/2..	7/8
43..	24. 0 1/2	3/4..	6
44..	24. 7 1/8	11..	1 1/8
45..	25. 1 7/8	1/4..	1 1/4
46..	25. 8 5/8	1/2..	3 3/8
47..	26. 3 1/4	3/4..	1 1/2
48..	26. 10	12..	1 3/4
49..	27. 4 3/4		
50..	27. II 3/8		

**HIP OR VALLEY RAFTER**

Span Ft.	Length Ft. In.	Span In.	Lgth. In.
1..	9	1/4..	1/4
2..	I. 6	1/2..	3/8
3..	2. 3	3/4..	5/8
4..	3. 0	1..	3/4
5..	3. 9	1 1/4..	I
6..	4. 6	1 1/2..	1 1/8
7..	5. 3	3/4..	1 1/4
8..	6. 0	2..	1 1/2
9..	6. 9	1/4..	5/8
10..	7. 6	1/2..	7/8
11..	8. 3	3/4..	2
12..	9. 0	3..	1 1/4
13..	9. 9	1/4..	3 3/8
14..	10. 6	1/2..	5 3/8
15..	11. 3	3/4..	3 3/4
16..	12. 0	4..	3 3/8
17..	12. 9	1/4..	1 1/8
18..	13. 6	1/2..	3 3/8
19..	14. 3	3/4..	1 1/2
20..	15. 0	5..	1 3/4
21..	15. 9	1/4..	7/8
22..	16. 6	1/2..	4 1/8
23..	17. 3	3/4..	1 1/4
24..	18. 0	6..	1 1/2
25..	18. 9	1/4..	5 3/8
26..	19. 6	1/2..	7 3/8
27..	20. 3	3/4..	5
28..	21. 0	7..	1 1/4
29..	21. 9	1/4..	3 3/8
30..	22. 6	1/2..	5 3/8
31..	23. 3	3/4..	3 3/4
32..	24. 0	8..	1 6
33..	24. 9	1/4..	1 1/8
34..	25. 6	1/2..	3 3/8
35..	26. 3	3/4..	1 1/2
36..	27. 0	9..	1 3/4
37..	27. 9	1/4..	7 3/8
38..	28. 6	1/2..	7 1/8
39..	29. 3	3/4..	1 1/4
40..	30. 0	10..	1 1/2
41..	30. 9	1/4..	5 3/8
42..	31. 6	1/2..	7 3/8
43..	32. 3	3/4..	8
44..	33. 0	11..	1 1/4
45..	33. 9	1/4..	3 3/8
46..	34. 6	1/2..	5 3/8
47..	35. 3	3/4..	3 3/4
48..	36. 0	12..	1 9
49..	36. 9		
50..	37. 6		

# **WALL AND CEILING FRAMING**

**CARPENTRY SERIES**



WALL AND CEILING FRAMING  
CARPENTRY SERIES  
**JOB SHEET**

1

Student Name: \_\_\_\_\_ Score: \_\_\_\_\_

**LAY OUT WALL PARTITION LOCATIONS ON FLOOR.**

**BASIC SKILLS**

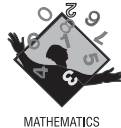

**INTRODUCTION**

Two common types of wall framing are platform framing and balloon framing. Most construction will call for the platform type of framing to be used. Platform framing is a wood frame construction method in which studs are one story high and a platform is built on the plates over the studs and acts as a base for the next floor. Platform framing is also known as western framing. Balloon framing is a residential construction method in which one-piece studs extend from the sill to the roof plate and the joists for the upper floors are nailed to the sides of studs. The most common of the two methods is platform framing.

Partition walls or interior walls are of either bearing or non-bearing. A bearing wall supports ceiling joists, while a nonbearing wall supports only itself. The building plans will provide the sizes of the interior walls or partitions and their locations. A good understanding of the building plans is essential to the overall quality of the finished product.



## EQUIPMENT AND SUPPLIES

- 8d nails
- 25' tape
- 8d Chalk line
- 8d Framing hammer
- 8d Framing square
- 8d Personal protective equipment
- 8d Steel tape

FIGURE 45

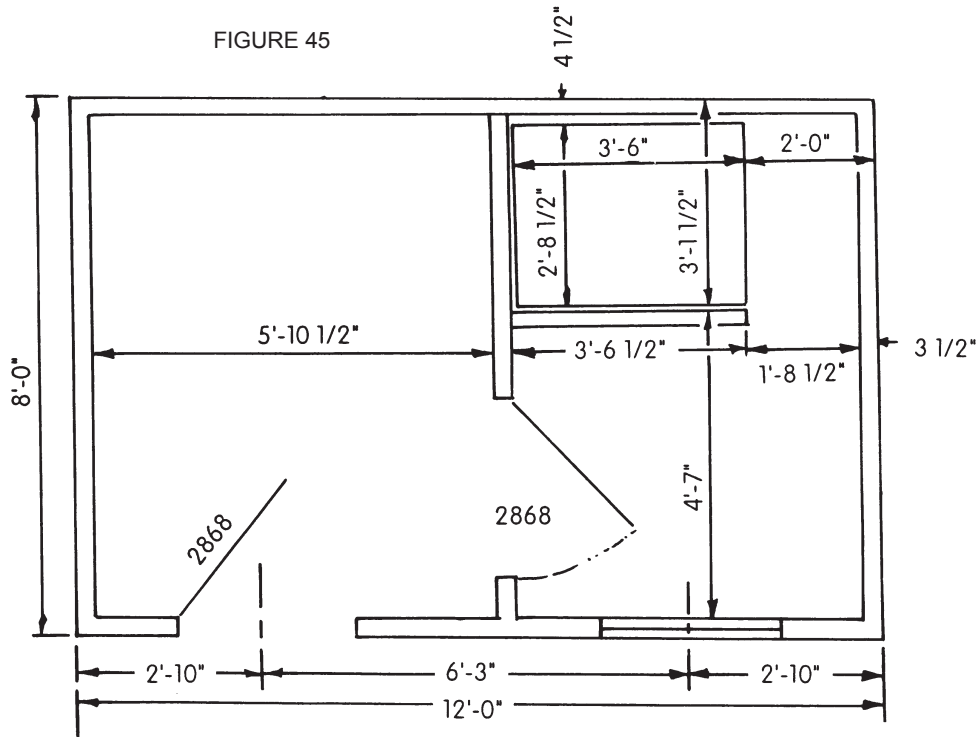

Scale: 3/8" = 1'-0"





FIGURE 46

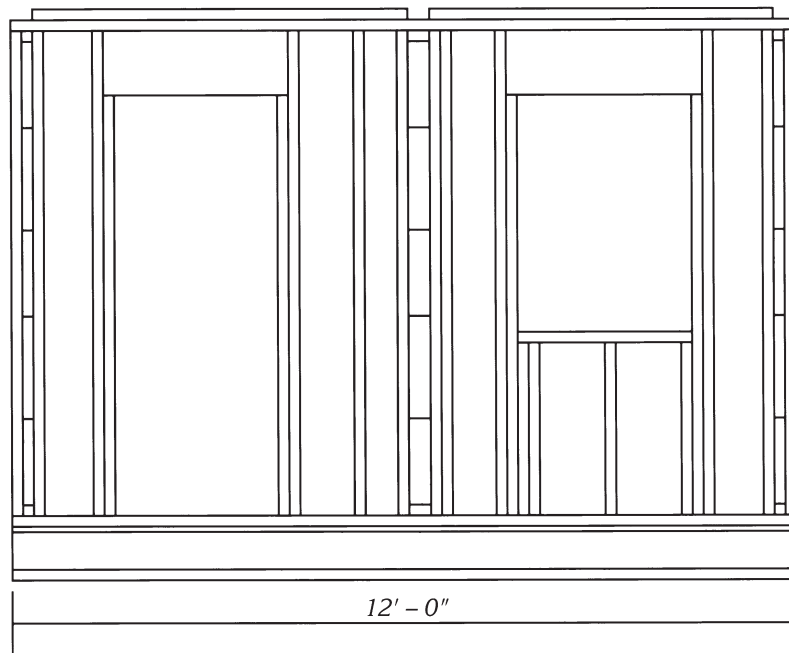

## PROCEDURE

**NOTE** ▶ Refer to Figure 45 and 46 for reference.

**Yes**   **No**

1. Lay out the outside walls.

A. Measure in the width of the soleplate from the outside edge of the floor on each end of the structure and mark this distance.

**NOTE** ▶ On concrete slab construction you must allow for sheathing thickness.

 

B. Start a nail at each mark.

C. Snap a chalk line between the marks.

FIGURE 47

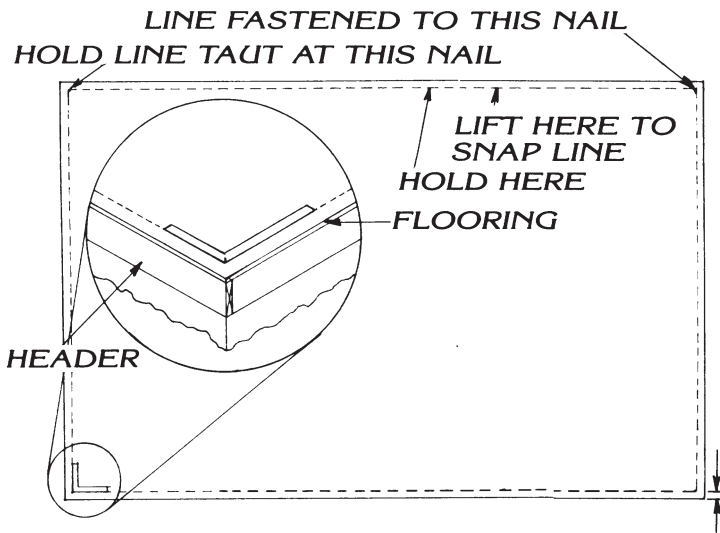

Yes No

D. Check for square of the sub floor by using the 3-4-5 method.

**NOTE** ▶ On longer walls, be sure the line is straight and well marked. Secure one end of the line and have someone hold the other end of the line and pull the line tight. Place your thumb on the line approximately in the center. Be sure to hold the line firmly to the floor. Carefully lift one side of the line with your other hand and let it snap to the floor. Repeat this process on the other half of the line.

E. Mark the other outside walls with the chalk line.

F. Make sure the outside walls are parallel.

2. Lay out the inside walls

**NOTE** ▶ Check for equal diameter dimensions and ensure overall square.

A. Mark each of the partitions.

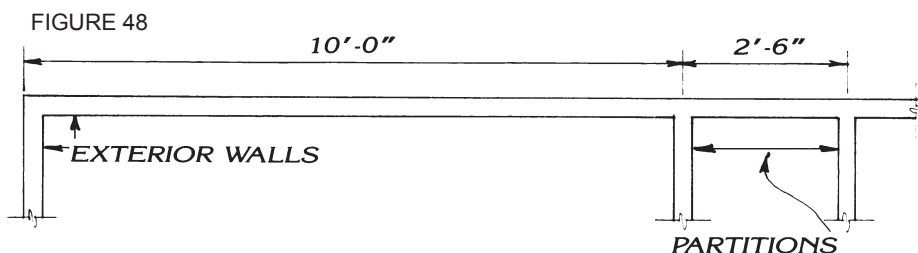



Yes No

- B. Repeat this procedure for the other side of the wall.
- C. Stretch a chalk line very tightly along the length of the partition and snap a line.
- D. If the chalk lines are to be exposed to weather, protect the lines by using a clear protective coating.
3. Have your instructor check your work.
4. Clean up the area and put away the equipment and supplies.

## PRODUCT EVALUATION

### SKILL TEST RECORD

**Evaluator note:** Rate the student on the following criteria by circling the appropriate numbers. Each criterion must receive a rating of “3” or higher to demonstrate student mastery. (See Key below.) A student who is unable to demonstrate mastery should review the material and submit another product for evaluation.

Criteria:

Observed safety procedures	4	3	2	1
Used proper equipment correctly	4	3	2	1
Performed steps in a timely manner	4	3	2	1
Followed instructions	4	3	2	1
Provided satisfactory responses to questions asked	4	3	2	1

### AVERAGE RATING

**Evaluator note:** To obtain an average rating for the Profile of Training Mastery, total the points in Product Evaluation and divide by the total number of criteria. Circle the rating on the Key.

## KEY

- 4 **Skilled** — Can perform job with no additional training
- 3 **Moderately Skilled** — Has performed job during training program; limited additional training may be required
- 2 **Limited Skill** — Has performed job during training program; additional training is required to develop skill
- 1 **Unskilled** — Is familiar with process, but is unable to perform job

## EVALUATOR'S COMMENTS

---

---

---



Student Name: \_\_\_\_\_ Score: \_\_\_\_\_

**CUT STUDS, TRIMMERS, CRIPPLES, AND HEADERS TO LENGTH.**

**BASIC SKILLS**



READING



MATHEMATICS



CRITICAL  
THINKING



EMPLOYABILITY

**INTRODUCTION**

Studs, trimmers, cripples, and headers are made of 2 x 4s or 2 x 6s spaced 16" or 24" on center. The lumber used in wall framing call for stiffness, nail-holding ability, warp resistance, and ease. The length of the framing lumber comes in increments of two feet. Some vertical members are precut and come in standard lengths of 92<sup>5</sup>/<sub>8</sub> inches and 92<sup>1</sup>/<sub>4</sub> inches.

When cutting studs it is important to use straight material for the full-length studs. Use the less straight material for the trimmer and cripple studs. Remember that each header requires two pieces. Cut the longest headers first, and plan all your cuts to keep waste to a minimum. Spacers should be cut slightly less than the width of the header, and they should be at least 1<sup>1</sup>/<sub>2</sub>" wide. Three spacers are needed for short headers and more for longer headers.

FIGURE 49

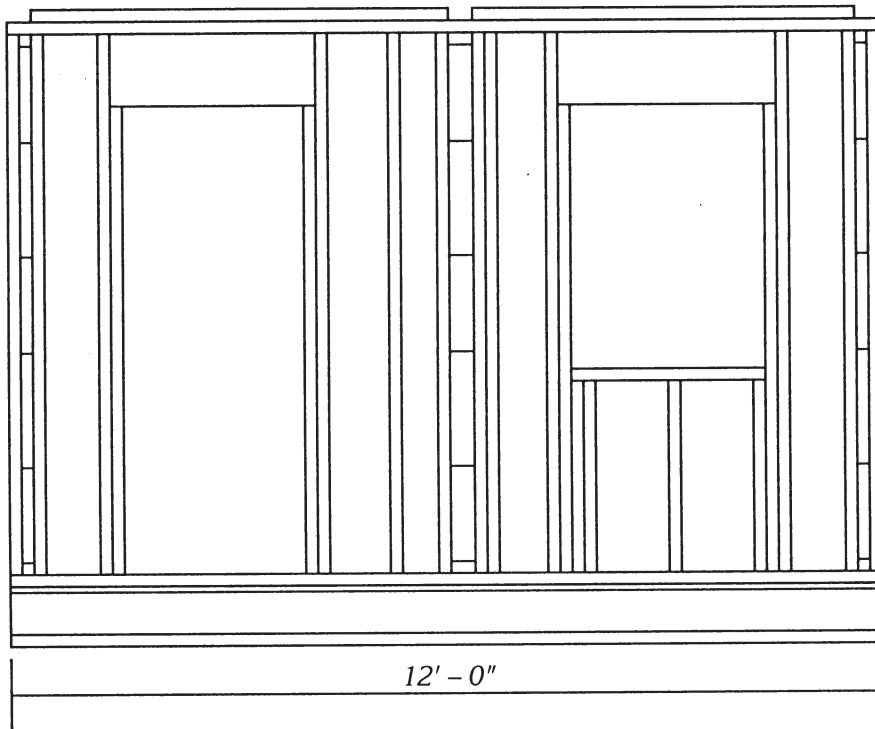

## EQUIPMENT AND SUPPLIES

- ½" CD plywood
- 2 x 4s or 2 x 6s
- 2 x 12s
- 16d box nails
- Circular saw
- Extension cord
- Framing hammer
- Framing square
- Personal protective equipment
- Steel tape

## PROCEDURE

Yes No

- |                          |                          |   |
|--------------------------|--------------------------|---|
| <input type="checkbox"/> | <input type="checkbox"/> | 1. Put on personal protective equipment.  |
| <input type="checkbox"/> | <input type="checkbox"/> | 2. Cut the studs.   |
| <input type="checkbox"/> | <input type="checkbox"/> | A. Determine the number of full studs needed.   |
| <input type="checkbox"/> | <input type="checkbox"/> | B. Determine the length of the full studs by subtracting the thickness of the sole plate, top plate, and double top plate from the wall height. |





Yes No

C. Measure and mark the length of the full studs.

D. Cut the first stud, following safety procedures.

E. Measure the stud again to make sure it is the right length.

F. If the stud is the correct length, use the stud as a pattern to cut the rest of the full studs.

**NOTE** ▶ It is important to use straight material for full studs. Use the less straight material for trimmer studs.

3. Cut the trimmer studs.

A. Determine the lengths of the trimmers.

**NOTE** ▶ The trimmer length equals the height of the header less the thickness of the sole plate.

B. Determine how many trimmer studs of each length are needed.

C. Measure and mark the length of the longest trimmer stud.

D. Cut the longest trimmer stud.

4. Cut the cripple studs.

A. Determine how many lengths are needed.

**NOTE** ▶ The upper cripple equals the length of the stud less the length of the trimmer and the height of the header. The lower cripple equals the height of the bottom rough opening less the sill and the sole plate.

B. Determine the number of each length needed.

C. Measure and mark the length of the longest cripple stud.

D. Cut the longest cripple stud.

**NOTE** ▶ Use the shortest material available to cut the cripple stud.



Yes No

E. Repeat this procedure for each length of cripple stud, cutting the next shorter length with each cut.

5. Cut the material for the headers.

**NOTE ►** On some jobs a different type of header may be specified or multiple trimmers.

A. Determine the length of headers needed.

**NOTE ►** The header length equals the rough opening width plus the thickness of the two trimmers.

B. Determine the number of the headers needed for each size opening.

**NOTE ►** All headers require two pieces. Cut the longest header first and plan all your cuts to keep waste to a minimum.

C. Measure and mark the length of the longest header.

D. Use the framing square to square a line across the header.

E. Cut the longest header.

F. Repeat the entire process for each length of header.

6. Cut spacers for the headers from ½" plywood.

**NOTE ►** Spacers should be cut slightly less than the width of the header and they would be at least 1½" wide. Three spacers are needed for short headers and more are needed for longer headers.

7. Have your instructor check your work.

8. Clean up the area and put away the equipment and supplies.

## PRODUCT EVALUATION

### SKILL TEST RECORD

**Evaluator note:** Rate the student on the following criteria by circling the appropriate numbers. Each criterion must receive a rating of "3" or higher to





demonstrate student mastery. (See Key below.) A student who is unable to demonstrate mastery should review the material and submit another product for evaluation.

Criteria:

Observed safety procedures	4	3	2	1
Used proper equipment correctly	4	3	2	1
Performed steps in a timely manner	4	3	2	1
Followed instructions	4	3	2	1
Provided satisfactory responses to questions asked	4	3	2	1

## AVERAGE RATING

**Evaluator note:** To obtain an average rating for the Profile of Training Mastery, total the points in Product Evaluation and divide by the total number of criteria. Circle the rating on the Key.

## KEY

- 4 Skilled** — Can perform job with no additional training
- 3 Moderately Skilled** — Has performed job during training program; limited additional training may be required
- 2 Limited Skill** — Has performed job during training program; additional training is required to develop skill
- 1 Unskilled** — Is familiar with process, but is unable to perform job

## EVALUATOR'S COMMENTS

---

---

---



Student Name: \_\_\_\_\_ Score: \_\_\_\_\_

**ASSEMBLE CORNERS, TS, AND HEADERS.**

**BASIC SKILLS**



**INTRODUCTION**

The important considerations are solid corner and nailing surfaces for the interior and exterior wall finishes. In addition, try to choose the straightest, least defective studs for corner assemblies.

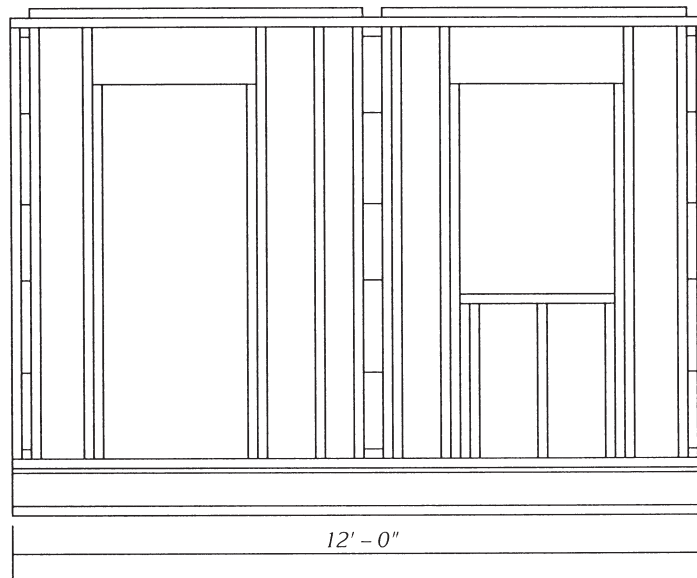

FIGURE 50

## EQUIPMENT AND SUPPLIES

- ½" CD plywood cut for header spacers
- 2 x 12 header material cut to length
- 16d box nails
- Circular saw
- Extension cord
- Framing hammer
- Personal protective equipment
- Steel tape
- Stock for blocking
- Studs

## PROCEDURE

Yes No

1. Put on personal protective equipment.
2. Construct the corners.
- A. Stack the materials in an out-of-the-way but convenient location.
- B. Review the plans to determine the number of corners needed.

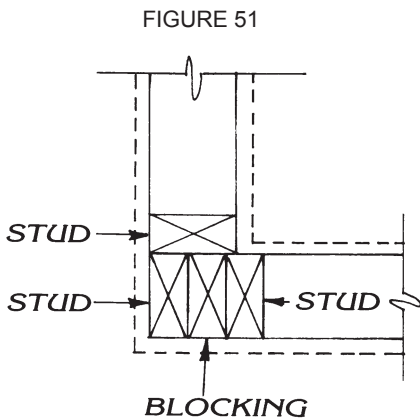
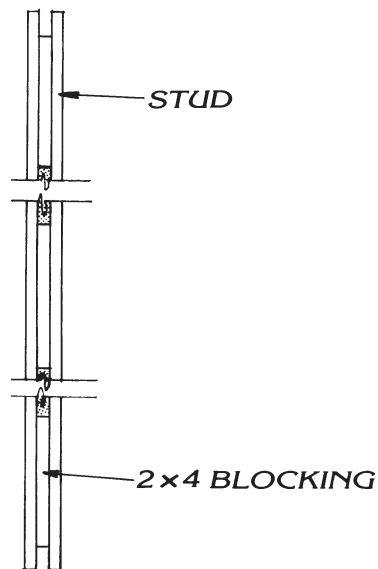

FIGURE 52





Yes No

C. Select three of the straightest studs for each corner to ensure that the corners are plumb.

D. Construct the corners as you see them in the Figure 53.

**NOTE** ▶ Use three blocking pieces that are 10" to 16" long for each corner. Scrap material may be used.

FIGURE 53

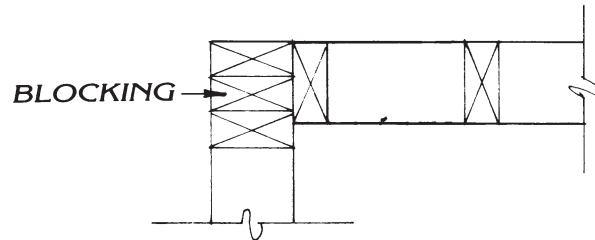

E. Nail two studs together with the blocking in between.

3. Construct the partition Ts. See figures 54 and 55.

A. Decide which material is needed for the type of T you are building.

FIGURE 54

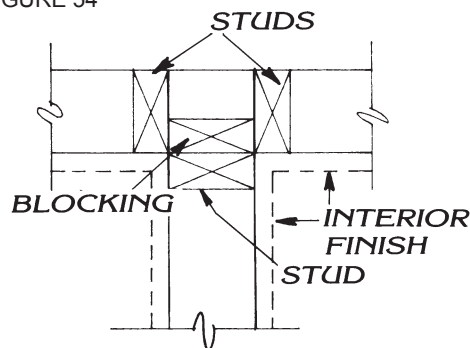
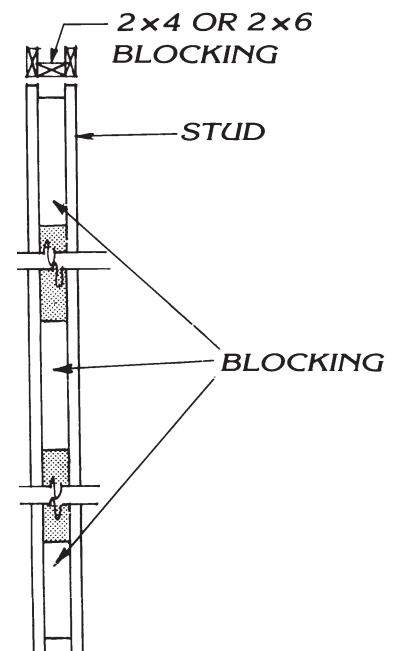
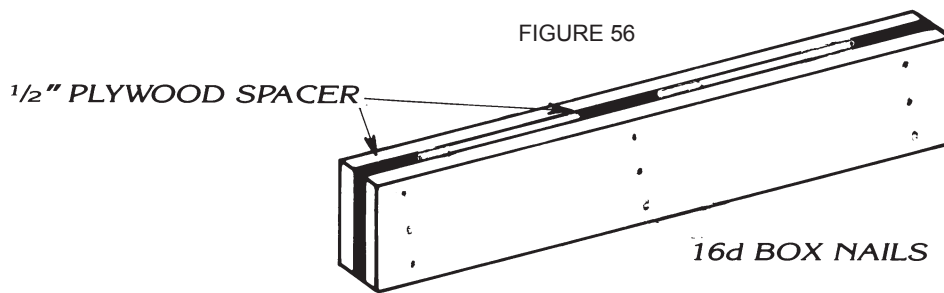

FIGURE 55



- B. Select two of the straightest studs for the T.
- C. Use three blocking pieces that are 10" to 16" long for each T.
- D. Nail the two studs together with the blocking in between.
- 4. Construct the headers. See Figure 56.
  - A. Mark the crown on the header materials.
  - B. Arrange the plywood spacers 16" to 24" apart along one of the 2 x 12s.
  - C. Place the second 2 x 12 on top of the spacers with the edges even with the first 2 x 12.
  - D. Hold the second 2 x 12 in place with both crowns up, and drive the nails into it.



- E. Cut the rough sills using safety procedures.
  - NOTE ►** Determine the measurement for the cut using this formula: length of sill = width of rough opening.
- F. Cut one rough sill for each window.
  - NOTE ►** Some very heavy windows may require a double sill.
- 5. Have your instructor check your work.
- 6. Clean up the area and put away the equipment and supplies.



## PRODUCT EVALUATION

### SKILL TEST RECORD

**Evaluator note:** Rate the student on the following criteria by circling the appropriate numbers. Each criterion must receive a rating of “3” or higher to demonstrate student mastery. (See Key below.) A student who is unable to demonstrate mastery should review the material and submit another product for evaluation.

Criteria:

Observed safety procedures	4	3	2	1
Used proper equipment correctly	4	3	2	1
Performed steps in a timely manner	4	3	2	1
Followed instructions	4	3	2	1
Provided satisfactory responses to questions asked	4	3	2	1

### AVERAGE RATING

**Evaluator note:** To obtain an average rating for the Profile of Training Mastery, total the points in Product Evaluation and divide by the total number of criteria. Circle the rating on the Key.

### KEY

- 4 Skilled** — Can perform job with no additional training
- 3 Moderately Skilled** — Has performed job during training program; limited additional training may be required
- 2 Limited Skill** — Has performed job during training program; additional training is required to develop skill
- 1 Unskilled** — Is familiar with process, but is unable to perform job



## EVALUATOR'S COMMENTS

---

---

---



Student Name: \_\_\_\_\_ Score: \_\_\_\_\_

**CONSTRUCT WALL SECTIONS.**

**BASIC SKILLS**



**INTRODUCTION**

Interior walls are framed in the same method without regard to the system used for the exterior walls. There are a various ways to lay out and erect a framed wall. However, the modified tilt-up method as described in the procedure below is commonly used because of its efficiency and ease.

FIGURE 57

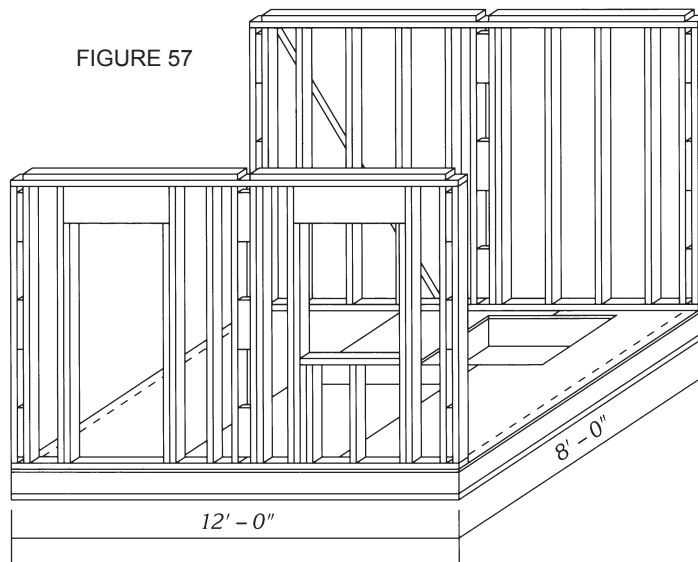

## EQUIPMENT AND SUPPLIES

- 4' level
- 6' step ladder
- 8d and 16d box nails
- 25' tape marked 16" on center
- Circular saw
- Corners
- Cripple studs
- Extension cord
- Framing square
- Headers
- Metal strapping brace material
- Personal protective equipment
- Plate material
- Regular studs
- Speed square
- Ts for partitions

## PROCEDURE

Yes No

- 1. Put on personal protective equipment.
- 2. Plan the sequence for raising the walls.  
**NOTE ►** Use the most productive and efficient sequence for your situation.
- 3. Select the materials from stock for the plates.
- 4. Cut the sole plate and top plate for the first wall to length, following safety procedures.
- 5. Tack the sole plate and the top plate for the first wall together and lay them on the edge at the wall location.
- 6. From the plans, lay out the following on the plates:
  - A. Rough openings
  - B. Corners
  - C. Partition T's
  - D. Stud locations
- 7. Mark the plates for the corners.
- 8. Locate the centers of the openings and lay out the trimmer stud locations. See Figure 58.
  - A. Determine the distance from the end of the plate to the center of the opening, according to the plan.





Yes No

B. Measure the required distance and mark it on the plate.

C. Measure and mark  $\frac{1}{2}$  the header length on each side of the center of the opening.

**NOTE** ▶ This locates the outside of each trimmer stud.

D. Recheck the dimensions.

E. Mark the trimmer stud locations with a "T".

F. Mark the cripple stud locations with a "C".

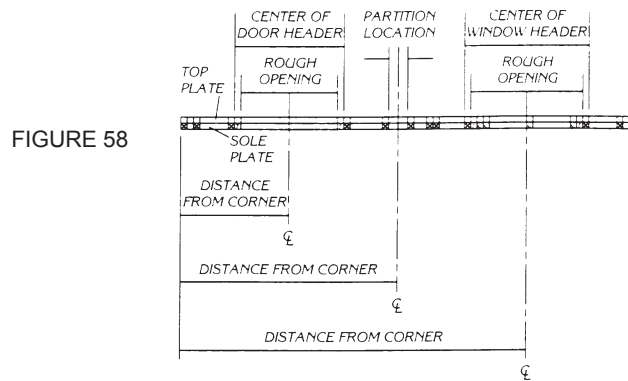

9. Use a tape to lay out all of the full stud locations. See Figure 59.

A. Measure  $15\frac{1}{4}$ " from the end of the outside corner to the leading edge of the first stud.

B. Drive a nail at this point and hook the end of the tape to the nail.

C. Mark 16" centers and place a small "X" to the far side of each mark.

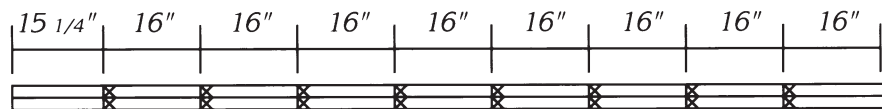

FIGURE 59

Yes No

D. Use a square to mark the stud locations across both of the plates. See Figure 60.

**NOTE** ▶ Another accepted method is to mark your plates on the edge. Splices in the plate must fall at the center of the stud.

FIGURE 60

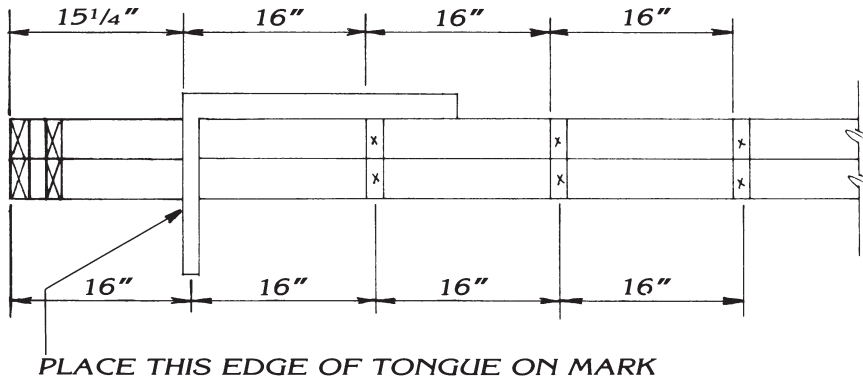

10. Build the wall with the inside of the wall facing down.
11. Place the soleplate at the partition line with the marked side up.
12. Move the top plate to the approximate stud length.
13. Place the corner and partition Ts at the appropriate mark.
14. Lay the studs at each "X" mark.
15. Check all the studs and turn them so that the crown is up.
- NOTE** ▶ If the studs are bowed too badly, they should be used for cripples or blocking.
16. Put the headers in place.
17. Place the trimmer studs at each "T" mark.
- NOTE** ▶ The trimmer studs and headers may be assembled prior to the wall assembly.





FIGURE 61

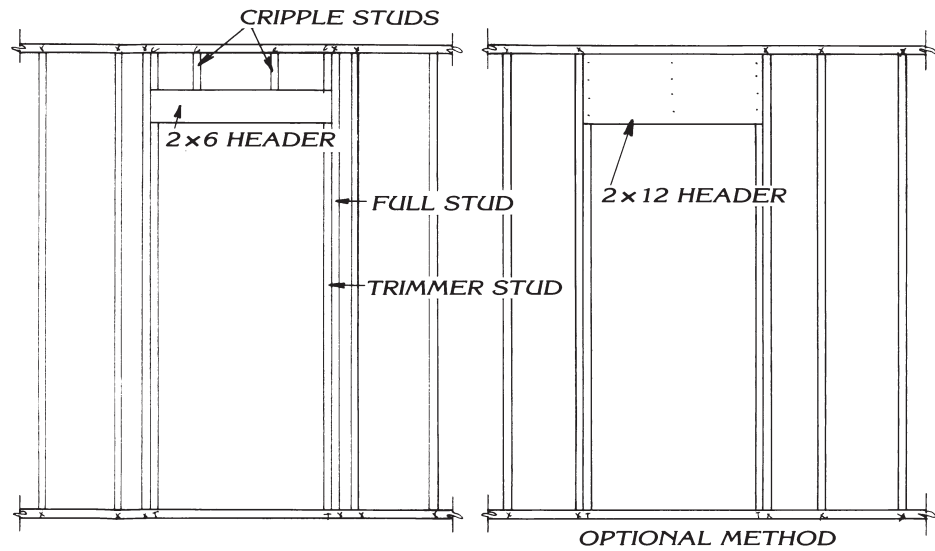

Yes No

18. Place the rough sills and cripple studs where the openings are located.

19. Nail the framework together. See Figure 62.

A. Drive two 16d nails through the plate into the end of each 2 x 4 stud or three nails for 2 x 6 studs.

**NOTE** ▶ The use of a nail gun is common practice. Special training is required to ensure safe use.

FIGURE 62

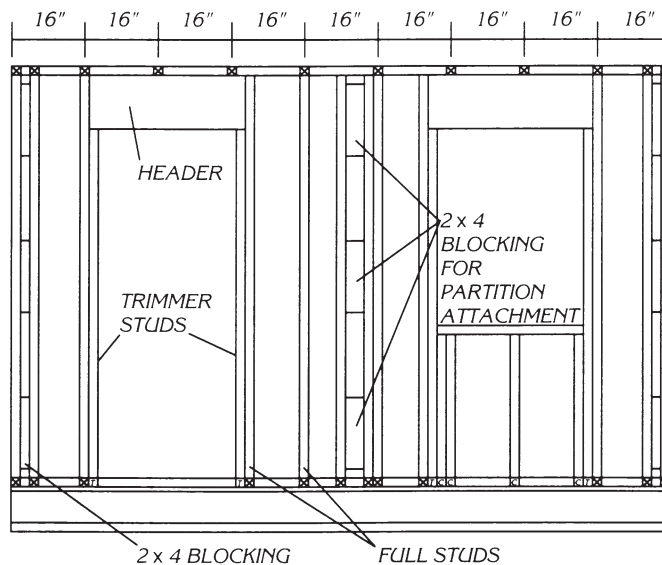

Yes No

- B. Install the headers and trimmers, or opening assemblies.
- C. Nail the cripple studs in place.
- D. Install rough sills and ensure all rough openings are the proper size.
- E. Finish nailing the framework together.
20. Measure and cut the double top plate. See Figure 63.
- NOTE** ► Be sure to allow for the overlap of corners and Ts.
- A. Cut the double top plate on the exterior walls to accept the plate from the other walls or partitions.

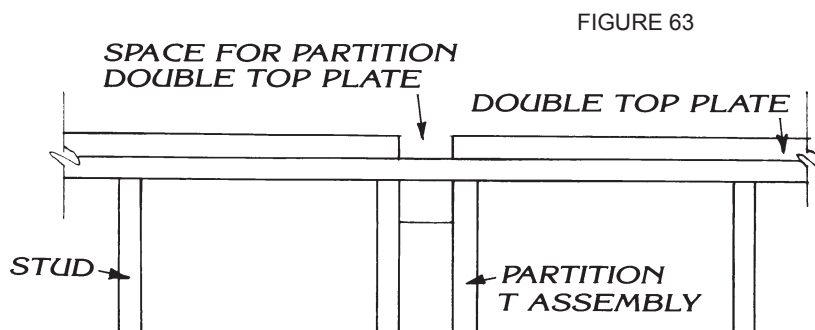

- B. Install the double top plates by first driving two 16d nails at one end of each double top plate section.
21. Drive one 16d nail on each side of the stud locations on opposite sides of the double top plate. See Figure 64.
- NOTE** ► Some permanent bracing requires preparation prior to installation of walls.
22. Raise the wall section and nail it in place.
- NOTE** ► To do this on wood floors, use two 16d nails every other floor joist. On concrete slabs, use pre-set anchor bolts or powder-actuated pins where appropriate. The use of powder-actuated tools requires special training to ensure their safe use.

**WARNING:** Before using a powder-actuated tool, you must be certified and possess a safety certification card.





FIGURE 64

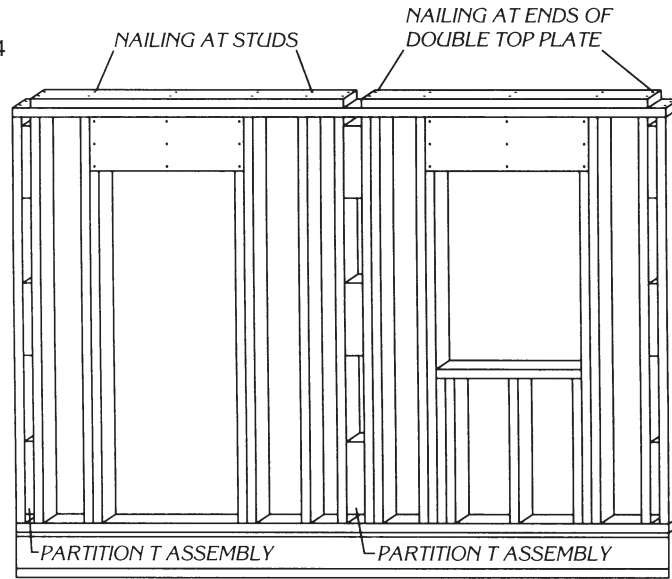

Yes No

- 23. Plumb the corners.
- 24. Attach temporary exterior braces.
- 25. Install remaining walls and brace in the same manner. See Figure 65.

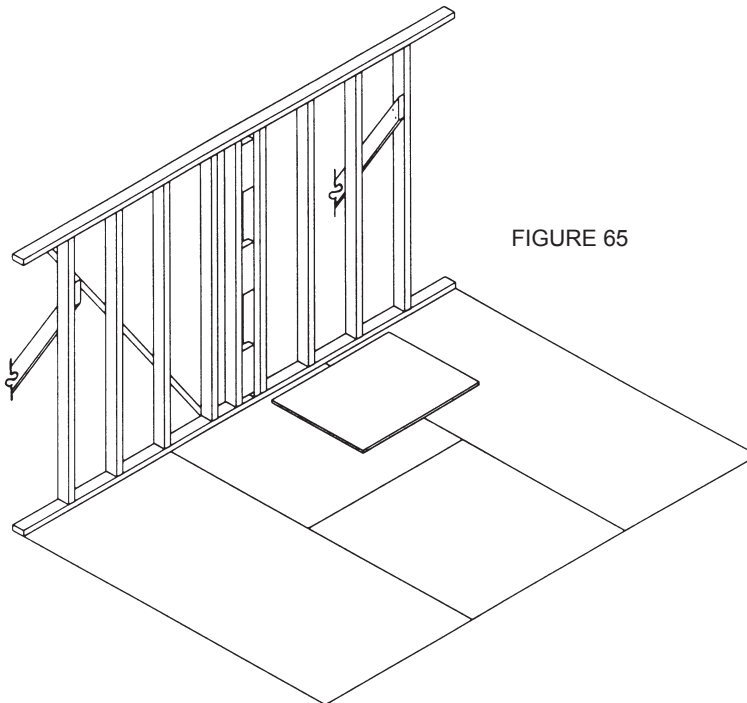

FIGURE 65



Yes No

26. Check the corners and adjust plumb if necessary.
27. Straighten the walls and nail the top of the temporary bracing in place. See Figure 66.
- A. Nail a  $\frac{3}{4}$ " block on each corner at the top of the walls.
- B. String a line from one end of the wall to the other.  
**NOTE** ▶ Be sure to stretch the line very tightly so that it does not sag.
- C. Use a  $\frac{3}{4}$ " gauge block to check the wall line.
- D. Adjust and nail the bracing during the straightening process.  
**NOTE** ▶ Be sure the bracing does not extrude beyond the exterior wall.

FIGURE 66

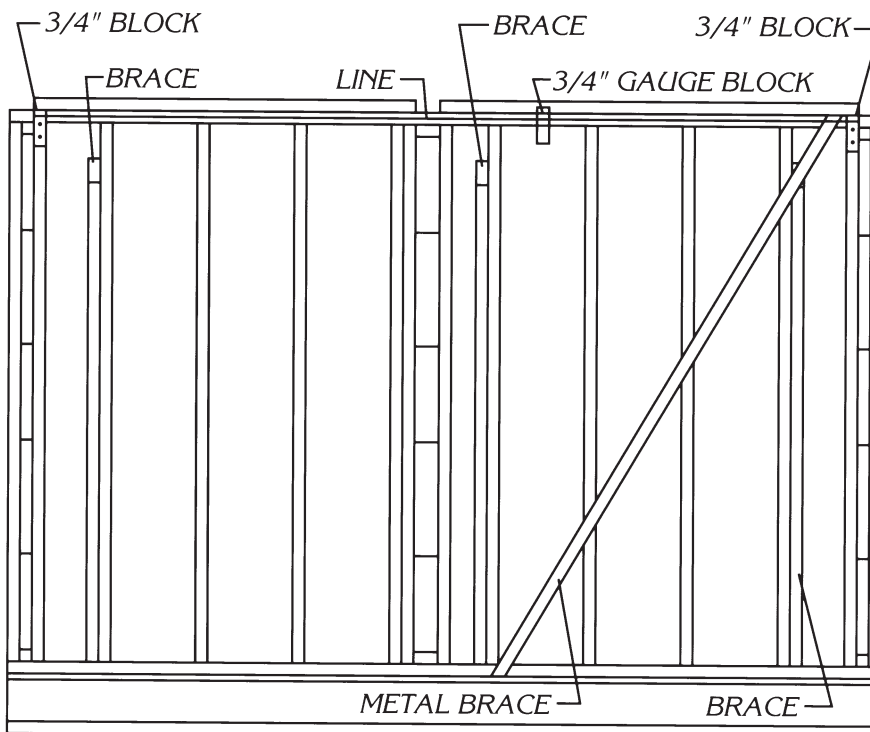



**Yes**   **No**

- 28. Install the appropriate permanent bracing.
- 29. Remove the exterior temporary bracing that is no longer needed.
- 30. Have your instructor check your work.
- 31. Clean up the area and put away the equipment and supplies.

## PRODUCT EVALUATION

### SKILL TEST RECORD

**Evaluator note:** Rate the student on the following criteria by circling the appropriate numbers. Each criterion must receive a rating of “3” or higher to demonstrate student mastery. (See Key below.) A student who is unable to demonstrate mastery should review the material and submit another product for evaluation.

Criteria:

Observed safety procedures	4	3	2	1
Used proper equipment correctly	4	3	2	1
Performed steps in a timely manner	4	3	2	1
Followed instructions	4	3	2	1
Provided satisfactory responses to questions asked	4	3	2	1

### AVERAGE RATING

**Evaluator note:** To obtain an average rating for the Profile of Training Mastery, total the points in Product Evaluation and divide by the total number of criteria. Circle the rating on the Key.

## KEY

- 4 **Skilled** — Can perform job with no additional training
- 3 **Moderately Skilled** — Has performed job during training program; limited additional training may be required
- 2 **Limited Skill** — Has performed job during training program; additional training is required to develop skill
- 1 **Unskilled** — Is familiar with process, but is unable to perform job

## EVALUATOR'S COMMENTS

---

---

---



Student Name: \_\_\_\_\_ Score: \_\_\_\_\_

**LAY OUT AND INSTALL CEILING JOISTS.**

**BASIC SKILLS**



READING



MATHEMATICS



CRITICAL  
THINKING



EMPLOYABILITY

**INTRODUCTION**

Ceiling joists are normally installed after the walls are erected and before the roof is framed. However, in laying out and installing the ceiling joists, the roof design must be considered. Your instructor may choose to teach this procedure after you have studied roof framing.

Some suggestions to speed up the ceiling joist installation are:

- Cut joist to correct length.
- Trim the outer ends of the joists to the correct roof slope.
- Have a helper hand the joists up to someone on the top.
- Lay out the joists flat across the span at their proper location.
- If spacing is the same as the studs, nail the joists directly above the studs, this allow for pipes, flues, ducts and so on that run through the roof to be installed more easily.
- Use a carpenter on each end when nailing joists in place.

## EQUIPMENT AND SUPPLIES

- 16d box nails
- 25' tape with markings at 16" centers
- Circular saw
- Extension cord
- Framing hammer
- Framing square or speed square
- Joists, lengths and sizes as specified
- Personal protective equipment

## PROCEDURE

Yes No

- |                          |                          |   |
|--------------------------|--------------------------|---|
| <input type="checkbox"/> | <input type="checkbox"/> | 1. Put on all personal protective equipment.  |
|                          |                          | 2. Lay out joist locations on double top plate.   |
| <input type="checkbox"/> | <input type="checkbox"/> | A. For Gable Roof. See Figure 67.   |
|                          |                          | 1) Determine which direction the joist will run.  |
|                          |                          | <b>NOTE</b> ▶ They are usually placed parallel to the shortest dimension of the structure; however, refer to the plans. |
|                          |                          | 2) Locate the outside of the first joist flush with the outside corner of the double top plate.                         |

FIGURE 67

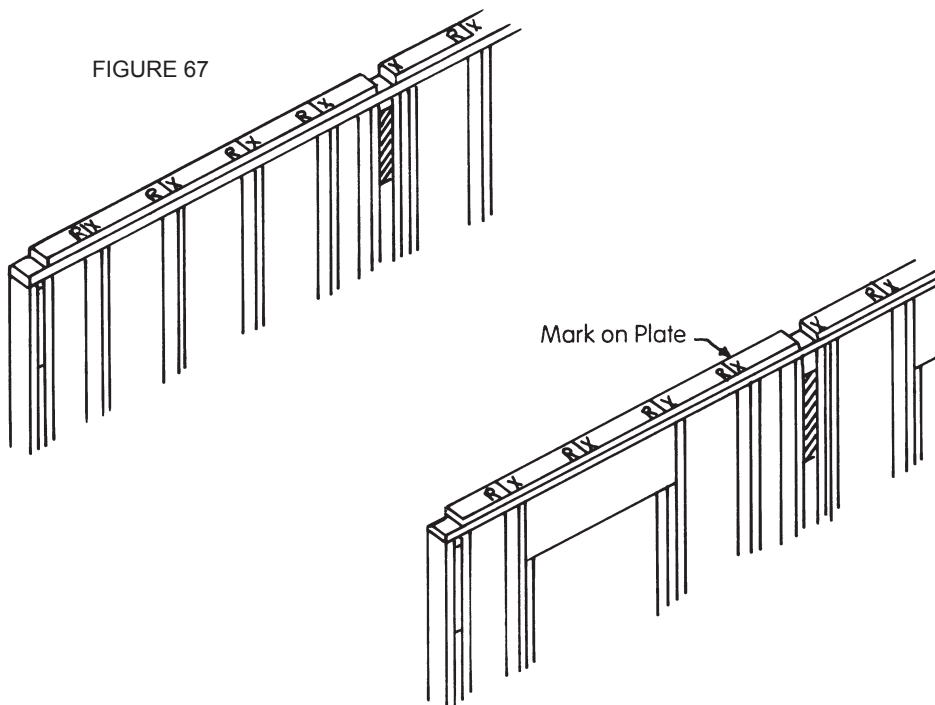



Yes No

- 3) Measure  $15\frac{1}{4}$ " from the end of the outside corner to the closest edge of the first joist.
- 4) Drive a nail and hook the end of the tape to the nail.
- 5) Lay out for 16" centers and place an "X" on the side where the joist will be placed and place an "R" on the side where the rafter will be located.
- 6) Repeat steps 3 - 6 on the opposite wall or on the bearing partition.

**NOTE** ▶ Be sure to reverse the measuring procedure.



B. For a hip roof. See Figure 68.

- 1) Determine which direction the joist will run.

**NOTE** ▶ They are usually placed parallel to the shortest dimension of the structure; however, refer to the plans.

- 2) Determine the length of run and transfer this measurement to the double top plate.
- 3) Measure  $15\frac{1}{4}$ " from the end of the outside corner to the closest edge of the first joist.
- 4) Drive a nail and hook the end of the tape to the nail.

FIGURE 68

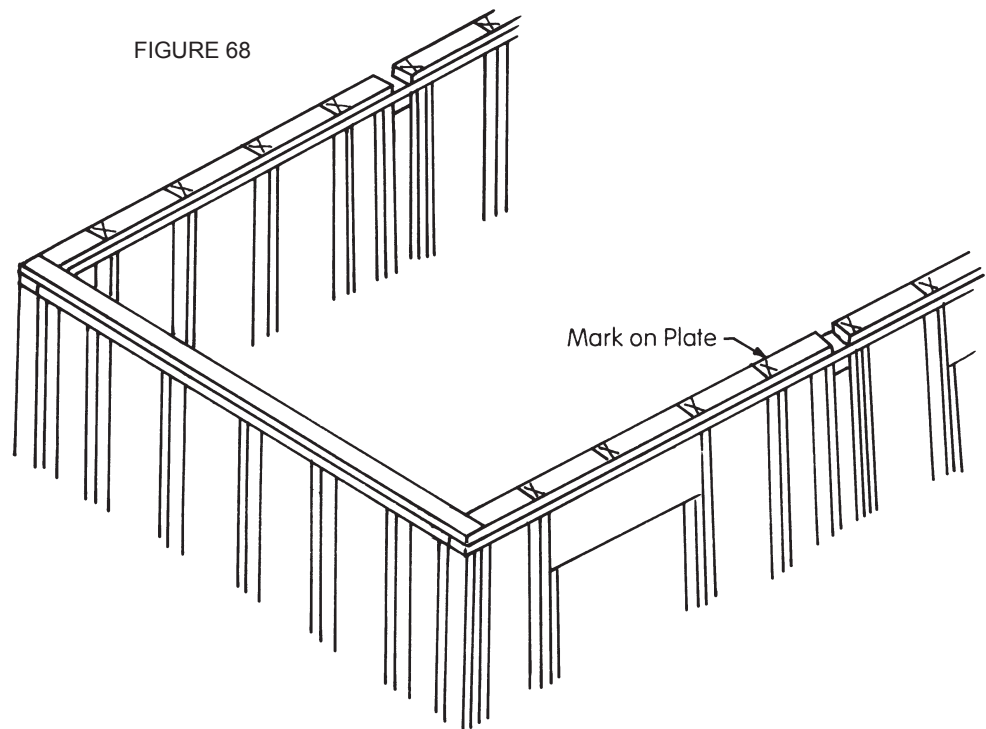

- 5) Lay out for 16" centers and place an "X" on the side where the joist will be placed.
  - 6) Repeat steps 3 - 6 on the opposite wall or on the bearing partition.
- NOTE** ▶ Be sure to reverse the measuring procedure.
- 7) Establish center of end wall and mark.
  - 8) Measure 15¼" from the end of the outside corner to the closest edge of the first joist.
  - 9) Drive a nail and hook the end of the tape to the nail.
  - 10) Lay out for 16" centers and place an "X" on the side where the joist will be placed.
  - 11) Repeat steps 8 - 11 on the opposite wall or on the bearing partition.

Yes No

3. Install ceiling joist

A. Cut the joist ends to the pitch of the roof. See Figure 69.

B. Place one joist, crown up, on each mark that was made on the plate.

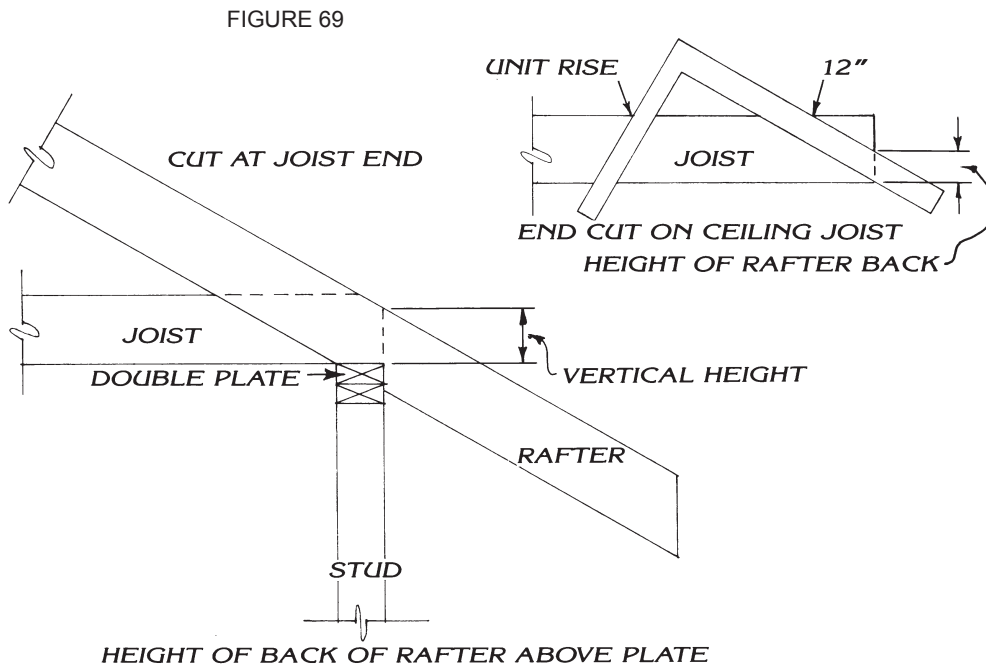
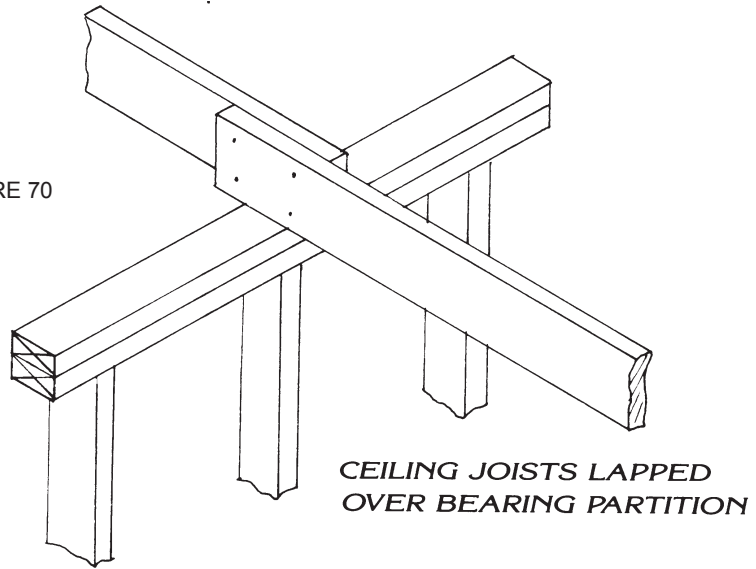



FIGURE 70



Yes No

C. Splice the joist on the bearing. See Figure 70.

**NOTE** ▶ There should be a minimum overlap of 6".

D. Toenail the joist to the plate with three nails.

FIGURE 71

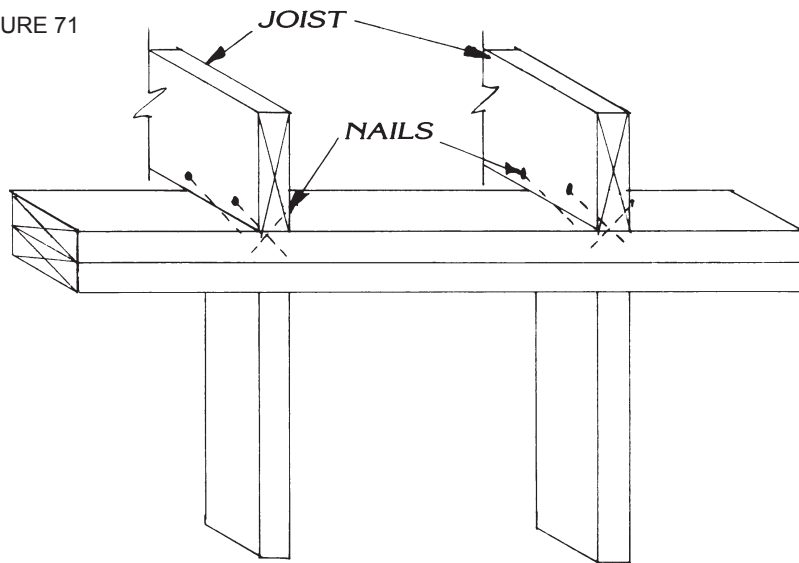

4. Have your instructor check your work.

5. Clean up area and put away equipment and supplies.



# PRODUCT EVALUATION

## SKILL TEST RECORD

**Evaluator note:** Rate the student on the following criteria by circling the appropriate numbers. Each criterion must receive a rating of “3” or higher to demonstrate student mastery. (See Key below.) A student who is unable to demonstrate mastery should review the material and submit another product for evaluation.

Criteria:

Observed safety procedures	4	3	2	1
Used proper equipment correctly	4	3	2	1
Performed steps in a timely manner	4	3	2	1
Followed instructions	4	3	2	1
Provided satisfactory responses to questions asked	4	3	2	1

## AVERAGE RATING

**Evaluator note:** To obtain an average rating for the Profile of Training Mastery, total the points in Product Evaluation and divide by the total number of criteria. Circle the rating on the Key.

## KEY

- 4 Skilled** — Can perform job with no additional training
- 3 Moderately Skilled** — Has performed job during training program; limited additional training may be required
- 2 Limited Skill** — Has performed job during training program; additional training is required to develop skill
- 1 Unskilled** — Is familiar with process, but is unable to perform job

## EVALUATOR’S COMMENTS

---

---

---



Student Name: \_\_\_\_\_ Score: \_\_\_\_\_

**INSTALL FIBERBOARD OR INSULATION-PANEL, DRYWALL,  
AND PLYWOOD SHEATHING.**

**BASIC SKILLS**



**INTRODUCTION**

Sheathing is the inner layer of the outside wall covering on a frame structure that forms a flat layer base upon which the siding or other material is applied. The sheathing adds strength and usually rigidity to the house. However, some sheathing may require bracing if the material is not rigid enough.

The most common types of sheathing are fiberboard, insulation-panel, gypsum board, and plywood. Plywood sheathing is used to cover large areas fast while adding strength and rigidity to the structure. Plywood holds nails well and provides a solid nailing base for the finish material. Plywood comes in 4' x 8' sheets and is usually applied vertically or horizontally. When applied horizontally, it will require diagonal corner bracing in the wall framework. The building plans will specify which method should be used to apply the sheathing.

Gypsum sheathing is composed of treated gypsum filler faced on both sides with lightweight paper. Gypsum comes in 2' x 8' or 4' x 8' sheets and is applied horizontally. The gypsum sheathing may be edged with a tongue and groove finish to ease in its application.

Wall sheathing may be applied at any one of three stages; when the wall is lying on the sub floor, completely framed and squared or when the wall and ceiling frames have been erected, plumbed, and braced. Most carpenters will apply the sheathing as quickly as possible to add strength and provide a solid surface for the ceiling members.

## EQUIPMENT AND SUPPLIES

- 1 x 4 for diagonal braces
- 1½" barbed roofing nails for gypsum board
- 2" ring shank roofing nails for fiberboard
- 6d box nail for plywood
- 8d box nail for braces
- Chalk line
- Circular saw
- Claw hammer
- Extension cord
- Framing square
- Fiberboard
- Gypsum board (Gyplap)
- Personal protective equipment
- Plywood
- Straightedge
- Steel tape

## PROCEDURE 1

### Install fiberboard or insulation-panel sheathing with plywood corner bracing

**NOTE** ► Follow manufacturer's recommendations for nailing, joints, and installation.

**Yes**   **No**

- |                          |                          |  |
|--------------------------|--------------------------|--|
| <input type="checkbox"/> | <input type="checkbox"/> | 1. Put on all personal protective equipment.   |
| <input type="checkbox"/> | <input type="checkbox"/> | 2. Apply a full sheet of plywood to each exterior corner of the structure.   |
| <input type="checkbox"/> | <input type="checkbox"/> | A. Chalk a line vertically on the sheathing at each stud.  |
| <input type="checkbox"/> | <input type="checkbox"/> | B. Start at the bottom of the corner of one wall and tack the panel in place.  |
| <input type="checkbox"/> | <input type="checkbox"/> | C. Complete the nailing.   |
|                          |                          | <b>NOTE</b> ► Space the nails 6" on the center of edges and 12" on the center for each stud.                                 |
| <input type="checkbox"/> | <input type="checkbox"/> | D. Continue the procedure, lapping the edges of the plywood at the corners until all the plywood bracing has been installed. |





FIGURE 72

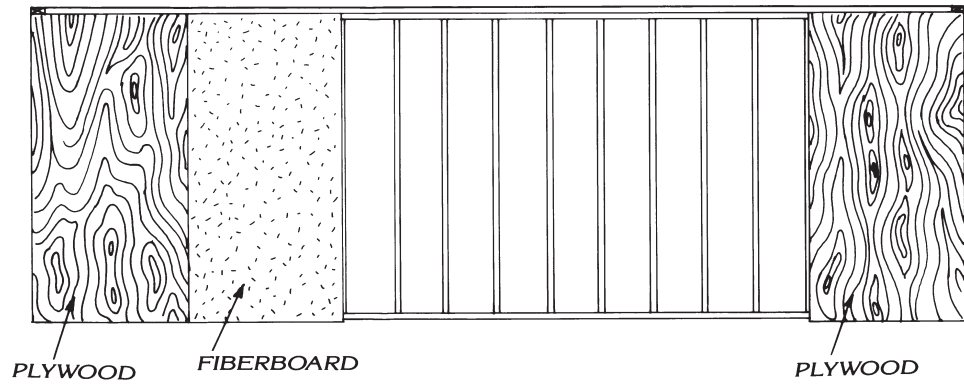

**Yes No**

- 3. Apply the fiberboard sheathing. See Figure 72.
  - A. Chalk the lines vertically on the sheathing at each stud.
  - B. Tack the panels in place.
  - C. Complete the nailing.
- NOTE** ▶ Space the nails 3" inches on the center at the edges and 6" on the center at each stud.
- 4. Have your instructor check your work.
  - 5. Clean up the area and put away the equipment and supplies.

## PROCEDURE 2

### Installation of gypsum-board sheathing with metal diagonal bracing

**Yes No**

- 1. Put on all personal protective equipment.
  - 2. Starting at the bottom of the corner of one wall tack the panel in place with the topside up. See Figure 73.
  - 3. Complete the nailing procedures as described above.
- NOTE** ▶ Nail as required for the type of exterior finish to be used.
- 4. Continue the installation, working up from the bottom and staggering the joints. See Figure 73.

FIGURE 73

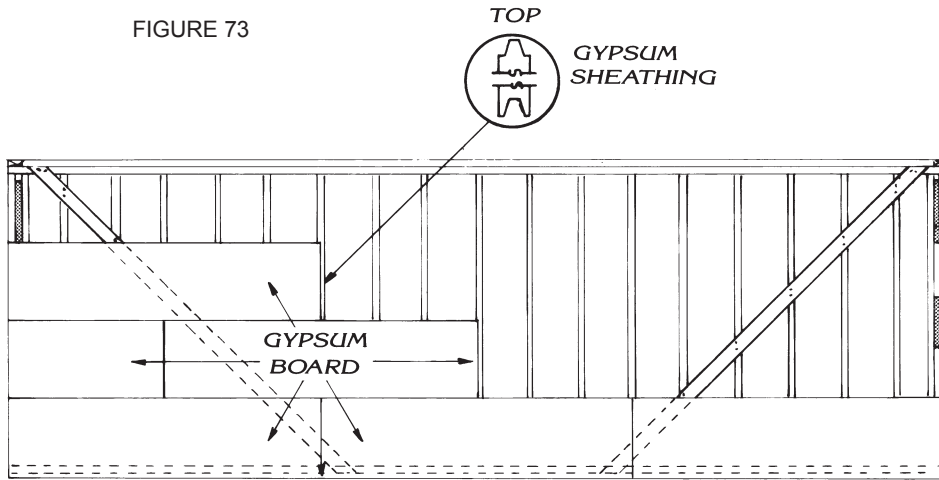

Yes No

- 5. Have your instructor check your work.
- 6. Clean up the area and put away the equipment and supplies.

### PROCEDURE 3

#### Installation plywood sheathing

Yes No

- 1. Put on all personal protective equipment.
- 2. Install a plywood panel at each corner for bracing. See Figure 74.  
**NOTE** ► No additional bracing is required when plywood is used.
- 3. Install intermediate panels.

Yes No

FIGURE 74

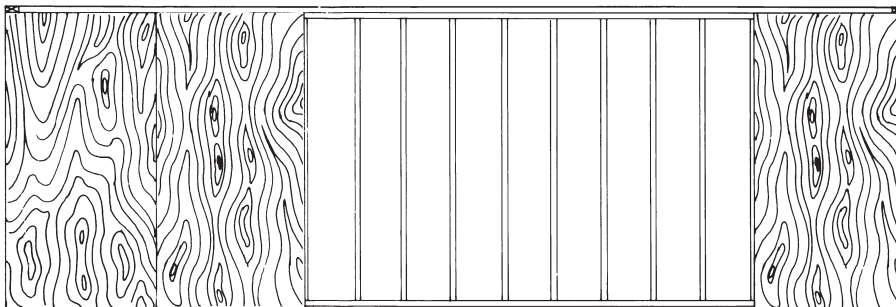



- 4. Have your instructor check your work.
- 5. Clean up the area and put away the equipment and supplies.

## PRODUCT EVALUATION

### SKILL TEST RECORD

**Evaluator note:** Rate the student on the following criteria by circling the appropriate numbers. Each criterion must receive a rating of “3” or higher to demonstrate student mastery. (See Key below.) A student who is unable to demonstrate mastery should review the material and submit another product for evaluation.

Criteria:

Nail spacing for plywood corners ¼"	4	3	2	1
Nail spacing for sheathing ¼"	4	3	2	1
Sheathing attached soundly	4	3	2	1
Gypsum-board staggered	4	3	2	1

### AVERAGE RATING

**Evaluator note:** To obtain an average rating for the Profile of Training Mastery, total the points in Product Evaluation and divide by the total number of criteria. Circle the rating on the Key.

### KEY

- 4 Skilled** — Can perform job with no additional training
- 3 Moderately Skilled** — Has performed job during training program; limited additional training may be required
- 2 Limited Skill** — Has performed job during training program; additional training is required to develop skill
- 1 Unskilled** — Is familiar with process, but is unable to perform job

## EVALUATOR'S COMMENTS

---

---

---



Student Name: \_\_\_\_\_ Score: \_\_\_\_\_

**INSTALL SHEATHING AND PLYWOOD SIDING.**

**BASIC SKILLS**



READING



MATHEMATICS



CRITICAL THINKING



EMPLOYABILITY

**INTRODUCTION**

Plywood siding comes in many grades, textures, and designs giving a greater variety of choices to the builder and architect. It is commonly applied vertically but it may be applied horizontally. However, all the edges of the panel siding should be backed with framing members. In addition, galvanized, aluminum, or other non-corrosive nails should be used to attach it to the framing members or blocking. It may have with flush joints, V-grooves, or other end treatments.

**EQUIPMENT AND SUPPLIES**

- 4 x 8 exterior plywood siding
- 4 x 8 fiberboard sheathing
- 6d and 8d galvanized box nails
- 48" level and straightedge
- Building paper for underlayment
- Caulking gun and caulking
- Chalk line
- Circular saw
- Claw hammer
- Extension cord
- Framing square
- Handsaw
- Personal protective equipment
- Sawhorses
- Staples or T-nails
- Steel tape



## PROCEDURE

Yes No



1. Check the corner for plumb, as it may be necessary to scribe and cut the first sheet of sheathing and siding. See Figure 75.

**NOTE** ▶ Use a level, as in Figure 75, or a plumb bob to check for plumb.

FIGURE 75

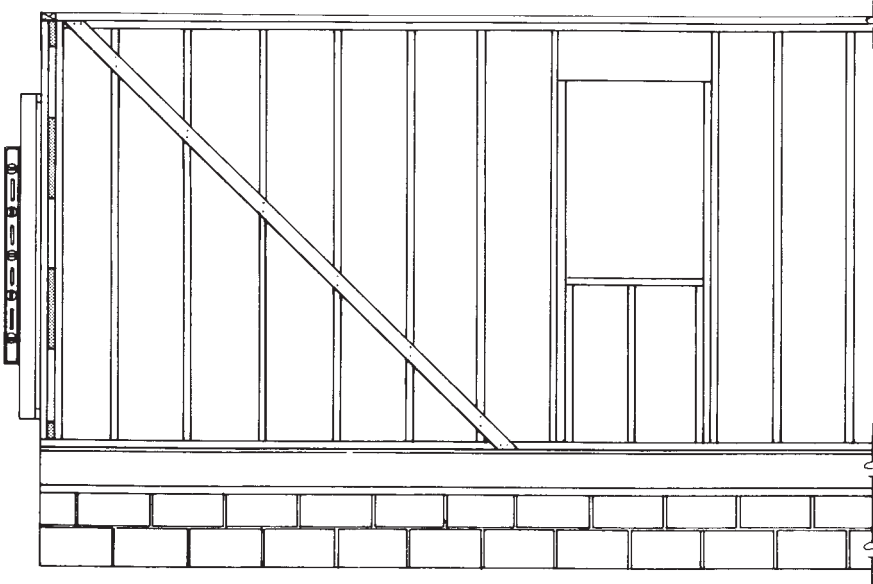

2. Install a 32" wide sheet of sheathing at the corner.

**NOTE** ▶ This narrow piece is necessary to avoid having the joints of the sheathing and siding on the same stud. If the plywood bracing is used, install a 32" wide sheet of siding as the first piece of siding.



3. Tack the first piece of sheathing in place.



4. Cut and install a band of sheathing to cover the rim joist if necessary. See Figure 76.



5. Install the next sheet of sheathing.



6. Install the underlayment.





FIGURE 76

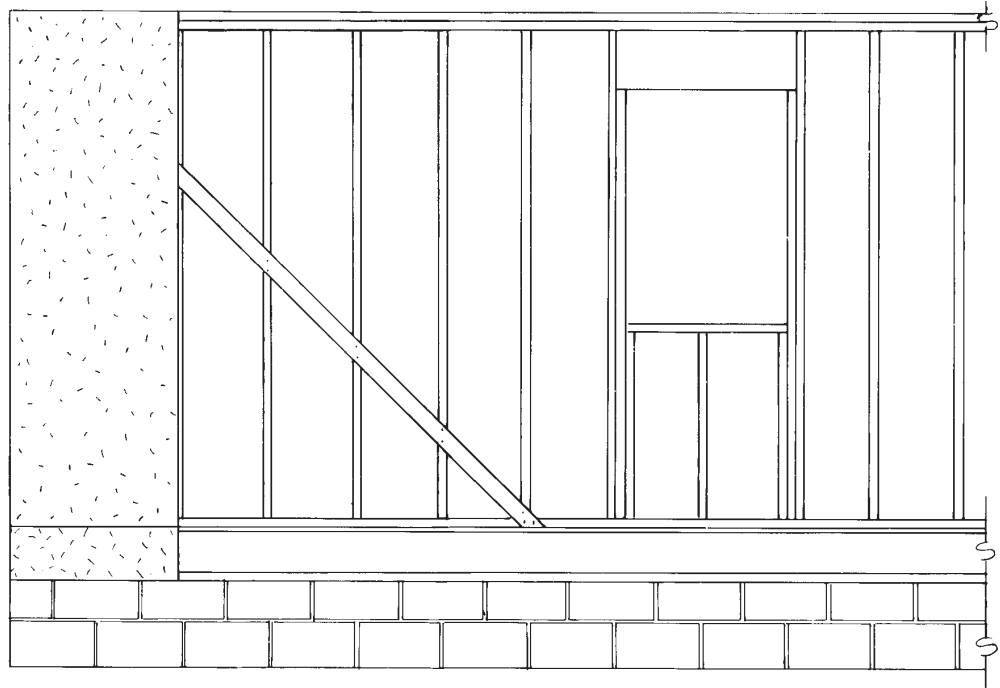

Yes No



7. Plumb and install the first sheet of siding. See Figure 77.

**NOTE** ▶ Space the nails every 6" on the edges and every 12" on intermediate studs. Place the nails about  $\frac{3}{8}$ " from the edge of the panels. Cut the siding from the unfinished side. When the corner trim is used, it may not be necessary to scribe and cut the siding.



8. Continue installing the sheathing and siding, leaving  $\frac{1}{16}$ " spacing at all edges and ends of siding for the shrinkage. See Figure 78.



9. Caulk all of the vertical joints.

**NOTE** ▶ When installing the horizontal siding, use the flashing and caulking. Z flashing is recommended.



10. Install flashing over windows and doors. See Figure 79.

FIGURE 77

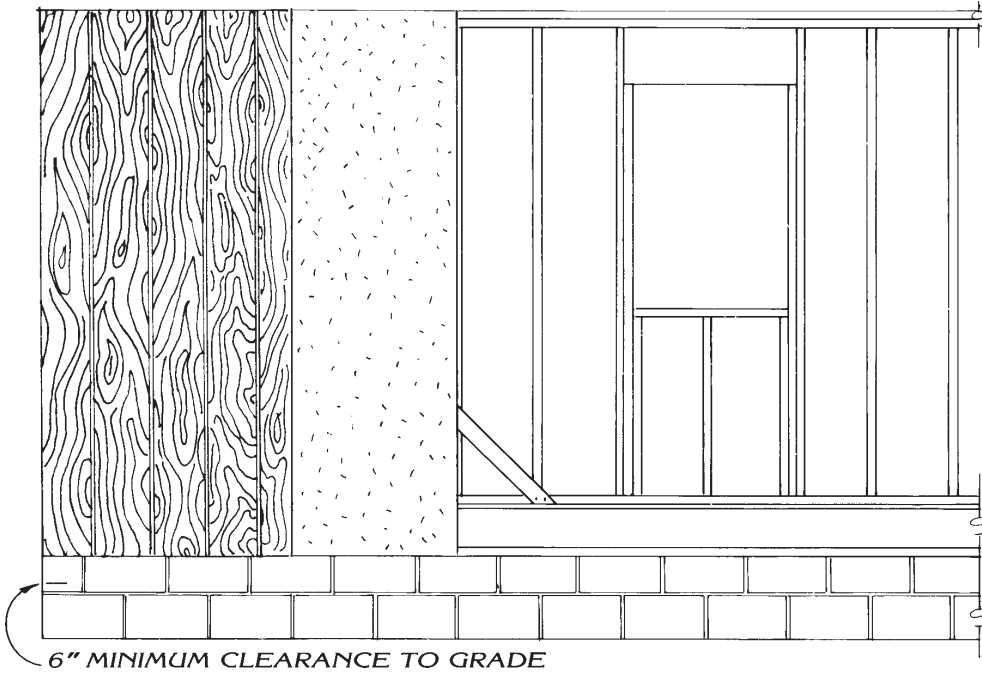
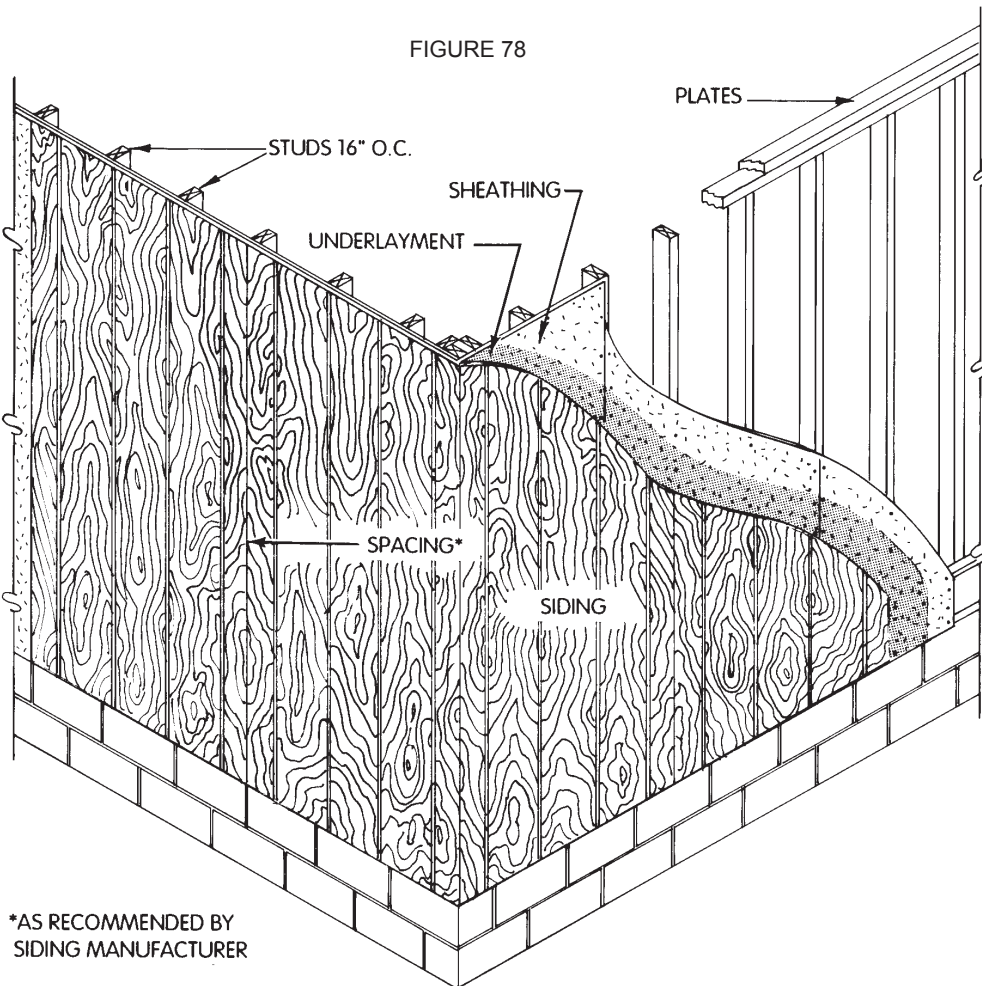

FIGURE 78



\*AS RECOMMENDED BY  
SIDING MANUFACTURER





Yes No

- 11. Caulk over the window and doors. See Figure 80.
- 12. Continue fitting and nailing until siding is completed. See Figure 81.
- 13. Have your instructor check your work.
- 14. Clean up the area and put away the equipment and supplies.

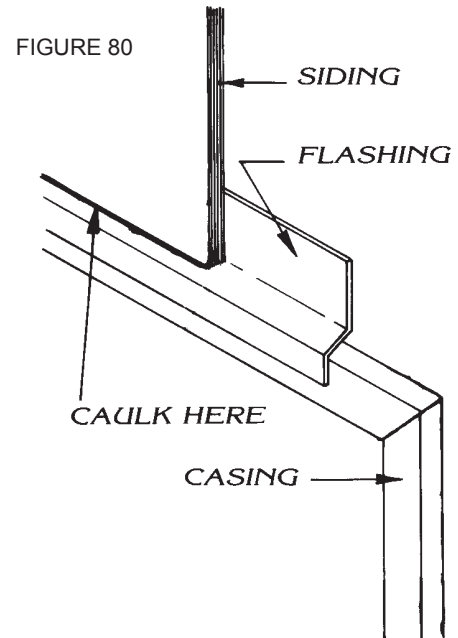
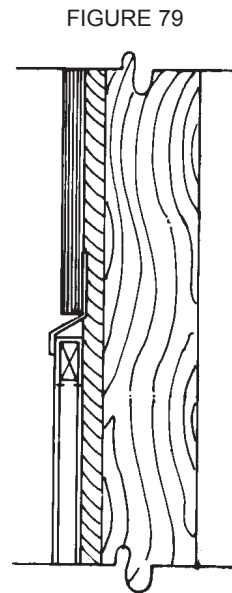
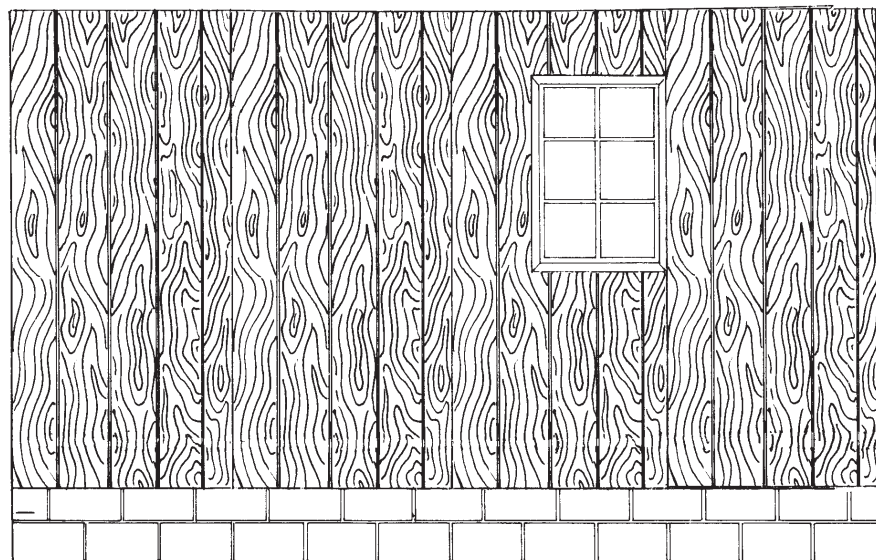

FIGURE 81



# PRODUCT EVALUATION

## SKILL TEST RECORD

**Evaluator note:** Rate the student on the following criteria by circling the appropriate numbers. Each criterion must receive a rating of "3" or higher to demonstrate student mastery. (See Key below.) A student who is unable to demonstrate mastery should review the material and submit another product for evaluation.

Criteria:

<u>Corners are plumb <math>\frac{1}{8}</math>"</u>	<u>4</u>	<u>3</u>	<u>2</u>	<u>1</u>
<u>First sheet of sheathing is 32"</u>	<u>4</u>	<u>3</u>	<u>2</u>	<u>1</u>
<u>Underlayment installed</u>	<u>4</u>	<u>3</u>	<u>2</u>	<u>1</u>
<u>Nail spacing in side panels correct <math>\frac{1}{4}</math>"</u>	<u>4</u>	<u>3</u>	<u>2</u>	<u>1</u>
<u>Correct spacing of siding panels and sheathing <math>\frac{1}{32}</math>"</u>	<u>4</u>	<u>3</u>	<u>2</u>	<u>1</u>

## AVERAGE RATING

**Evaluator note:** To obtain an average rating for the Profile of Training Mastery, total the points in Product Evaluation and divide by the total number of criteria. Circle the rating on the Key.

## KEY

- 4 Skilled** — Can perform job with no additional training
- 3 Moderately Skilled** — Has performed job during training program; limited additional training may be required
- 2 Limited Skill** — Has performed job during training program; additional training is required to develop skill
- 1 Unskilled** — Is familiar with process, but is unable to perform job

## EVALUATOR'S COMMENTS

---

---

---



# **STAIR FRAMING**

**CARPENTRY SERIES**



# STAIR FRAMING CARPENTRY SERIES JOB SHEET

Student Name: \_\_\_\_\_ Score: \_\_\_\_\_

## CONSTRUCT A STAIR.

### BASIC SKILLS

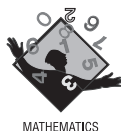

### INTRODUCTION

Building codes tightly regulate the dimensions and design of stairs because of the chance for serious injuries or deaths from falls. Be sure and review the building codes before beginning any stair construction project. The details for the stairs are found in the stairwell section of the building plans.

#### Words You Should Know

##### Skirtboard

a finish member installed at the meeting of a staircase and wall

### EQUIPMENT AND SUPPLIES

- 1 x 8s for risers
- 2 x 12s for stringers
- 2 x 12s for treads
- 3' level
- 8d and 16d box nails, 16d casing nails
- Building plans provided by instructor
- Circular saw and extension cord
- Claw hammer
- Folding rule or steel tape



- Framing square
- Handrail and brackets with manufacturer's instructions for hardware
- Handsaw
- Personal protective equipment
- Stair gauges

## PROCEDURE

Yes No



1. Put on all personal protective equipment.

**NOTE** ► For a stair between two walls you must allow room for the wall finish material.



2. Lay out the stringers.



- A. Check the plans to determine the number of risers and treads, the unit rise and unit run, and the number of stringers.

FIGURE 82

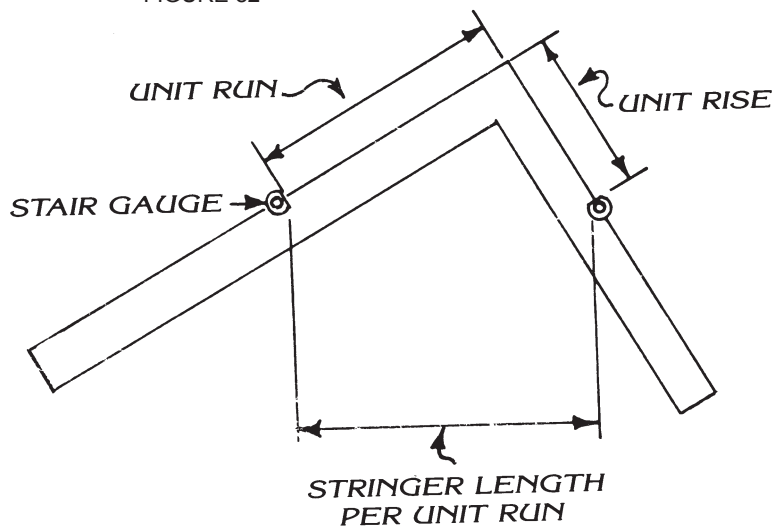

- B. Place the stair gauges of your framing square at exact unit rise and unit run.



- C. Lay out the tread and rise locations on the stringer material. See Figures 83 and 84.

**NOTE** ► Leave the space for the top-end cut. Be sure that the measurements and marks are exact.



FIGURE 83

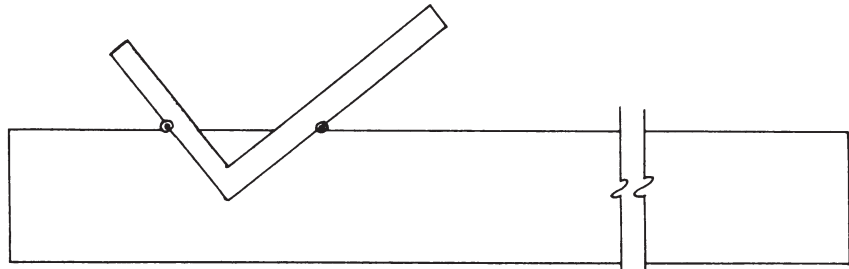

FIRST STEP IN STRINGER LAYOUT

FIGURE 84



STRINGER LAID OUT

Yes No

D. Lay out the top-end cuts. See Figures 85 and 86.

FIGURE 85

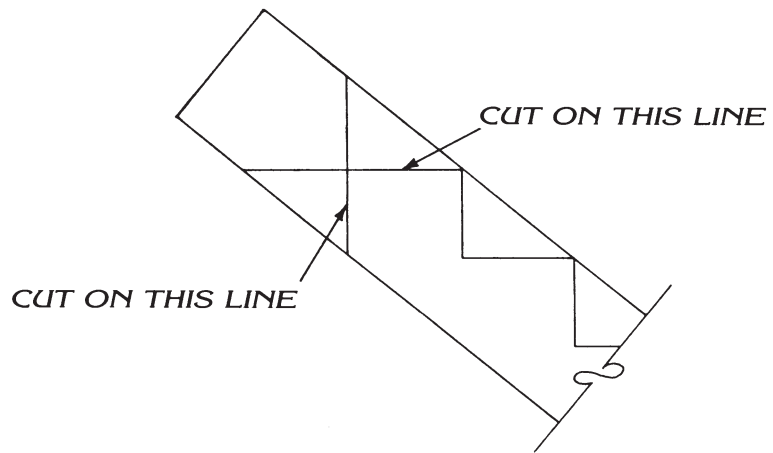
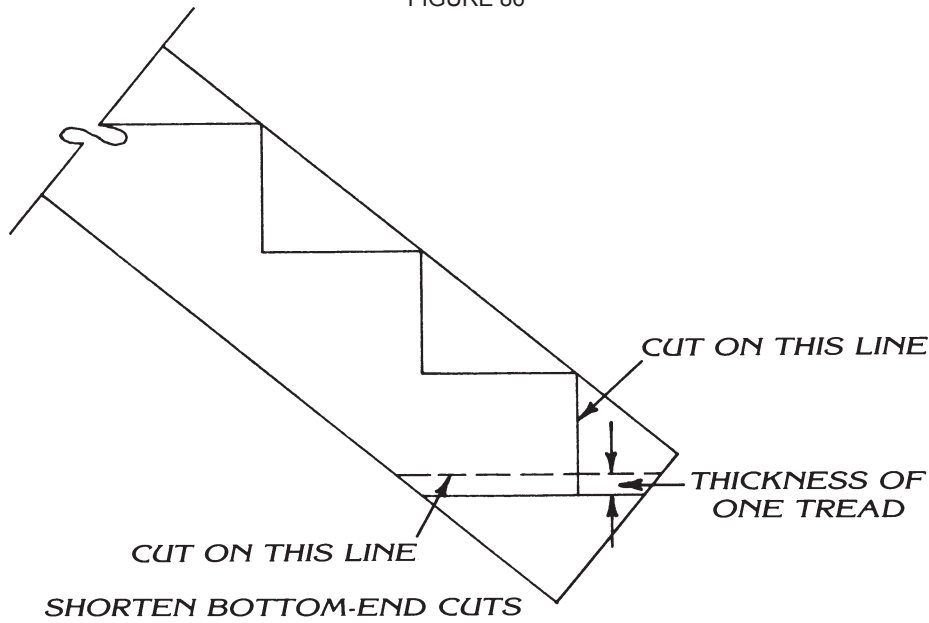

FIGURE 86



Yes No

E. Lay out the bottom-end cuts. See Figure 87.

**NOTE** ▶ Shorten the unit rise for the bottom step by the thickness of the tread so that the first step up from the floor will be the same unit rise as the other steps.

FIGURE 87

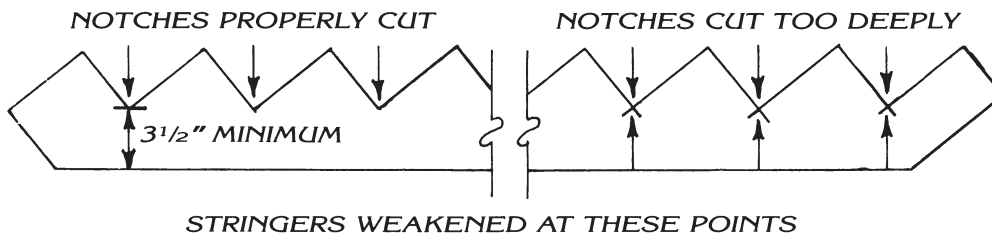

3. Cut the stringers with a circular saw, following all safety procedures.

**NOTE** ▶ Cut to the point of each notch. Cutting past the point weakens the stringer.

4. Use this first stringer as a pattern for the remaining stringers.

Yes No



5. Leave a minimum of 3½" from the point of the notch to the lower end of the stringer.



6. Finish each cut with a handsaw.

FIGURE 88

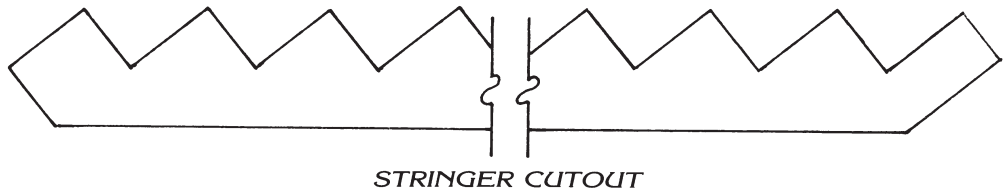

7. Cut the risers and treads to length and width.



8. Install spacer boards if required.



9. Place one stringer and check that all tread cuts are level.

**NOTE** ► Hold the stringer in place by nailing it to a kicker at the bottom and to a header at the top. You can also use hangers, straps, or ledger strips.

FIGURE 89

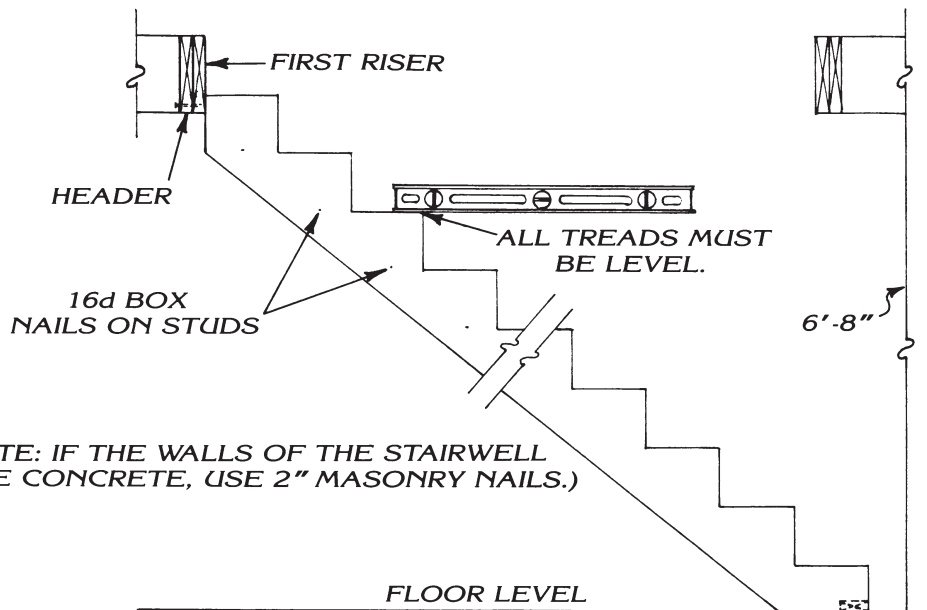

(NOTE: IF THE WALLS OF THE STAIRWELL ARE CONCRETE, USE 2" MASONRY NAILS.)

- | Yes                      | No                       |  |
|--------------------------|--------------------------|--|
| <input type="checkbox"/> | <input type="checkbox"/> | 10. Nail the other stringer or stringers in place. |
| <input type="checkbox"/> | <input type="checkbox"/> | 11. Install a skirtboard.                          |
| <input type="checkbox"/> | <input type="checkbox"/> | 12. Nail the risers in place with 8d box nails.    |

**NOTE** ► Be sure the top of the riser is flush with the thread cutout.

FIGURE 90

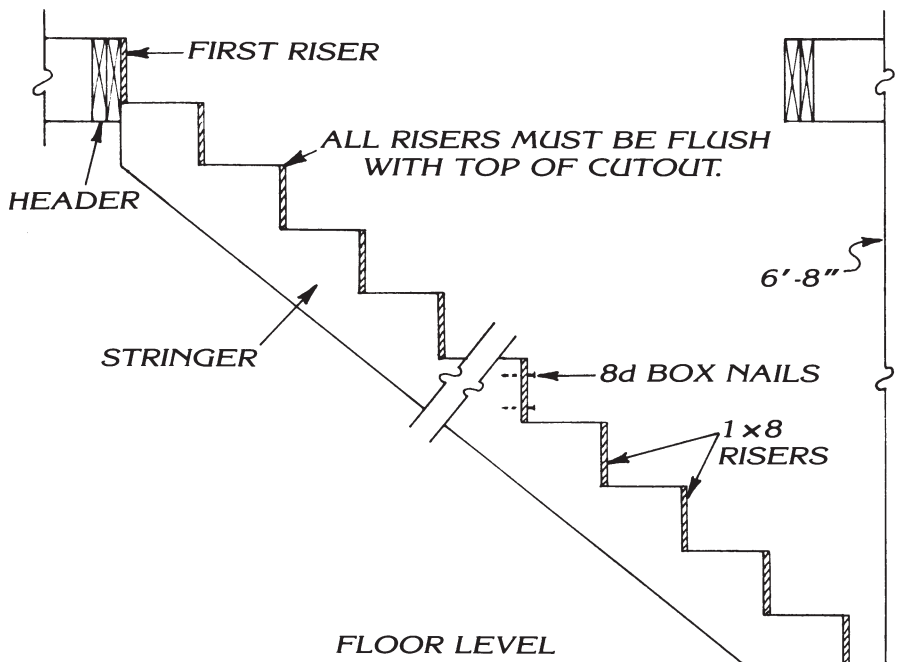

- |                          |                          |  |
|--------------------------|--------------------------|--|
| <input type="checkbox"/> | <input type="checkbox"/> | 13. Nail the treads in place with 16d casing nails.                    |
|                          |                          | <b>NOTE</b> ► Gluing treads in will help to avoid squeaks.             |
| <input type="checkbox"/> | <input type="checkbox"/> | 14. Use 8d box nails to fasten the riser to the tread.                 |
| <input type="checkbox"/> | <input type="checkbox"/> | 15. Install the handrail at the proper height per code specifications. |
| <input type="checkbox"/> | <input type="checkbox"/> | 16. Have your instructor check your work.                              |
| <input type="checkbox"/> | <input type="checkbox"/> | 17. Clean up the area and put away the equipment and supplies          |

## PRODUCT EVALUATION

### SKILL TEST RECORD

**Evaluator note:** Rate the student on the following criteria by circling the appropriate numbers. Each criterion must receive a rating of “3” or higher to demonstrate student mastery. (See Key below.) A student who is unable to demonstrate mastery should review the material and submit another product for evaluation.

Criteria:

Observed safety procedures	4	3	2	1
Used equipment correctly	4	3	2	1
Performed steps in a timely manner	4	3	2	1
Followed instructions	4	3	2	1
Provided satisfactory responses to questions asked	4	3	2	1

### AVERAGE RATING

**Evaluator note:** To obtain an average rating for the Profile of Training Mastery, total the points in Product Evaluation and divide by the total number of criteria. Circle the rating on the Key.

### KEY

- 4 Skilled** — Can perform job with no additional training
- 3 Moderately Skilled** — Has performed job during training program; limited additional training may be required
- 2 Limited Skill** — Has performed job during training program; additional training is required to develop skill
- 1 Unskilled** — Is familiar with process, but is unable to perform job

## EVALUATOR'S COMMENTS

---

---

---



# **CORNICE AND GABLE ENDS**

**CARPENTRY SERIES**





Student Name: \_\_\_\_\_ Score: \_\_\_\_\_

## BUILD A HORIZONTAL BOX CORNICE.

### BASIC SKILLS



### INTRODUCTION

Before building a horizontal box cornice it is prudent to check the plumb cuts on the tail-rafters. Some carpenters wait to cut the tail-rafters until they have been placed on the exterior wall. They use a chalk line to draw a plumb line down the side of each rafter.

Gypsum board, plywood, and hardwood may be used for the soffit on a box cornice. They may be purchased in large sheets for wide overhangs. Plywood is the most common material used for the soffit. Plywood of various thickness is used for box soffits. The thickness of the plywood used will determine the maximum spacing of the supports, required nails, and nail spacing.

### EQUIPMENT AND SUPPLIES

- 1 x 2s for frieze
- 1 x 8s for fascia
- 2 x 4s for lookouts
- 2 x 4s for lookout ledger
- 2 x 6s for false fascia
- 4-foot level
- 8d box nails for lookout ledger
- 16d box nails for lookouts
- Chalk line
- Claw hammer

- Drill
- Framing square
- Galvanized 4d box nails for soffit
- Galvanized 8d casing nails for fascia
- Handsaw
- Miter box
- Pencil
- Personal protective equipment
- Plywood for soffit
- Radial arm saw or table saw
- Steel tape

## PROCEDURE

### Procedure for Hip Roof

Yes No

- 1. Put on personal protective equipment.
- 2. Install lookout ledger.
  - A. Make a mark on the corner of the structure where the lower edge of the lookout ledger will be located at a point level with the bottom of the false fascia. See Figure 91.

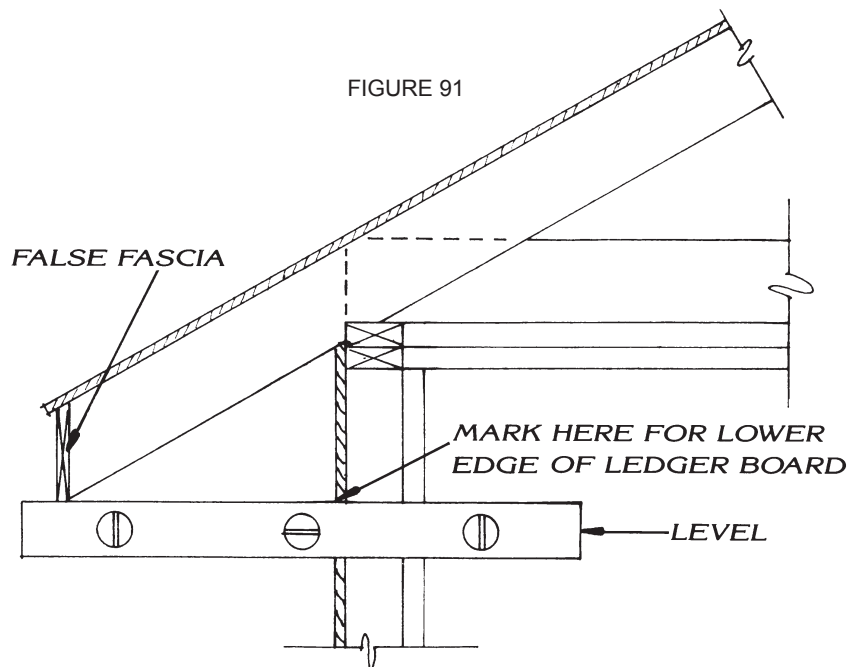

- B. Repeat step "A" at each corner of the structure.
- C. Snap a chalk line on each side of the structure between the corner marks.



Yes No

D. Place the bottom edge of the lookout ledger on the chalk line and nail to the form a band completely around the structure.

**NOTE ►** Nail two 16d box nails at each stud.

E. Mark a line on the lookout ledger even with one side of each rafter.

**NOTE ►** Always use the same side of each rafter.

3. Cut and install the lookouts.

A. To determine the correct length for the lookouts, measure from the inside of the lower edge of the false fascia to the outside of the lookout ledger.

B. Determine the number of lookouts needed.

C. Cut 2 x 4s to determined length.

D. Install the lookouts.

1) Use two 16d box nails to nail the outside end of each lookout to the side of each rafter.

**NOTE ►** Be sure to keep the outside end of the lookout flush with the bottom of the false fascia.

2) Use three 8d box nails to toenail the inside end of each lookout to the lookout ledger.

**NOTE ►** Be sure to keep the inside end of the lookout flush with the bottom of the lookout ledger.

4. Install the fascia.

A. Start at one corner of the structure and fit the fascia to it.

B. Miter the corners and all splices in the fascia.

C. Place the fascia with its top edge at the bottom side of the decking and its lower edge projecting below the soffit at least  $\frac{1}{2}$ ".

D. Nail the fascia in place, using two galvanized 8d casing nails spaced approximately every 16".

Yes No

5. Cut and install the soffit.

A. Determine the width of the soffit.

**NOTE** ► Most buildings require a 12", 16", or 24" soffit.

B. Rip the plywood panels lengthwise into strips of determined width.

**NOTE** ► If the precut panels are used, make sure the soffit material is wide enough and trim molding will cover the exposed areas.

C. Mark the bottom of the false fascia at the center of each lookout.

D. Mark the sheathing in the middle of each lookout directly under the lookout ledger.

E. Place the soffit on the marks and nail it with 4d galvanized nails, spacing the nails approximately every 6".

**NOTE** ► All splices must be on a lookout. The outside edge of the soffit must be flush with the outside edge of the false fascia.

6. Install the frieze.

A. For wood siding

1) Install the siding before installing the frieze.

**NOTE** ► See Job Sheet 2.

2) Place the frieze in the corner formed where the soffit meets the siding.

3) Nail the frieze in place, using 8d casing nails.

B. For brick veneer

**NOTE** ► The frieze may be made by ripping strips of 1" lumber as specified.

1) Measure 5" out from the sheathing on the soffit plus the thickness of the frieze board, and make a mark at each corner of the structure.

**NOTE** ► This spacing is for common brick size and will vary with brick size.



- 2) Snap a chalk line between the marks on the bottom side of the soffit.

**NOTE ►** This line is the outside of the frieze.

- 3) Nail the frieze to 1 x 4 blocking, using 8d galvanized casing nails; fasten the bottom of the brick, using masonry fasteners.

**NOTE ►** To keep from splitting the frieze, drill a hole through the frieze at each nail location.

### Procedure for Gable Roof

Yes No

1. Put on personal protective equipment.

2. Install the lookout ledger.

- A. Locate the lower edge of the lookout ledger, following steps 2a through d of the hip roof procedure.

- B. Install the lookout ledger only on the sides of the structure under the eave.

**NOTE ►** Run the lookout ledger past the ends of the building as far as the outer face of the barge rafter.

- C. Mark the lookout ledger on the specified centers to come out on the same side of each rafter.

3. Cut and install lookouts.

- A. To determine the correct length for the lookouts, measure from the inside the lower edge of the false fascia to the outside of the lookout ledger.

- B. Determine the number of lookouts needed.

- C. Cut 2 x 4s to determined length.

- D. Cut four end lookouts to fit the bottom of the barge rafter. See Figure 92.

FIGURE 92

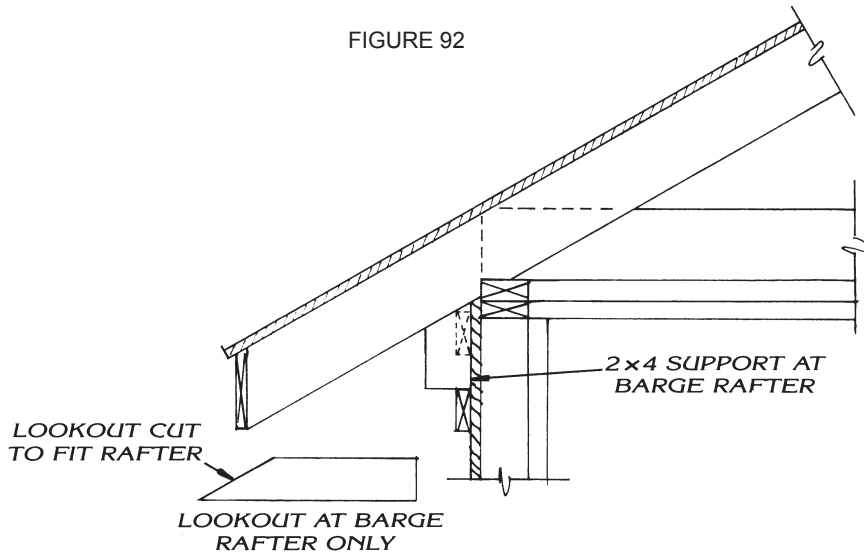

Yes No

E. Install the remainder of the lookouts.

- 1) Use two 16d nails to nail the outside end of each lookout to the sides of each rafter.

**NOTE ►** Be sure to keep the outside end of the lookout flush with the bottom of the false fascia.

- 2) Use three 8d box nails to toenail the inside end of each lookout to the lookout ledger.

**NOTE ►** Be sure to keep the inside end of the lookout flush with the bottom of the lookout ledger.

4. Cut and install the soffit.

A. Determine the width of the soffit.

B. Rip the plywood panels into strips of determined width.

**NOTE ►** The soffit for the rake of the roof may be different than for the eave.

C. Mark the bottom of the false fascia at the center of each lookout.

D. Mark the sheathing in the middle of each lookout directly under the lookout ledger.



Yes No

E. Place the soffit material on the marks and nail in place at the gable needs.

**NOTE** ▶ Stay at the peak of the rake and work down both sides. The lower ends need only to extend past the outside of the sheathing.

F. Nail the soffit in place under the eaves.

**NOTE** ▶ The soffit must be flush with the outside of the false fascia on the sides, flush with the outside face of the barge rafter on the ends, and flush with the outer face of the ledger where it projects past the end of the building.

FIGURE 93

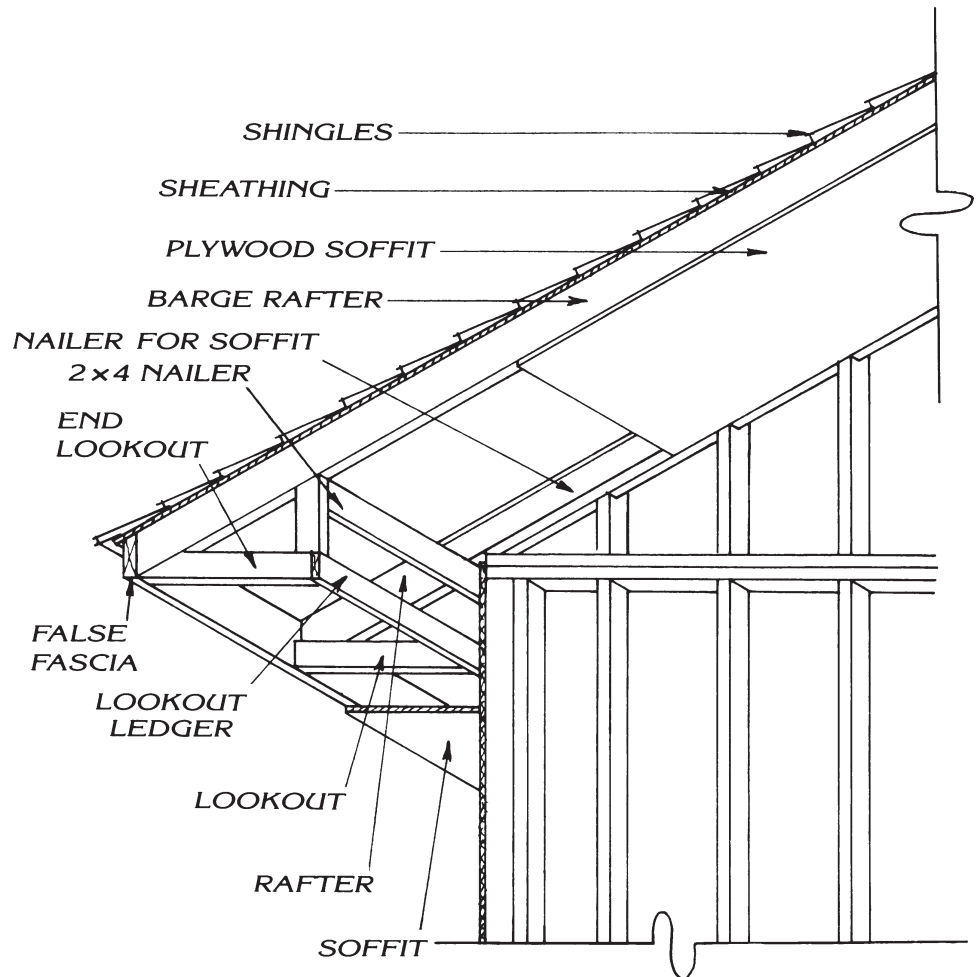



Yes No

5. Install fascia.

A. Start at one corner of the structure and fit the fascia.

B. Miter the corners and all splices in the fascia.

C. Place the fascia so that its top edge touches the bottom side of the shingles and its lower edge projects below the soffit at least  $\frac{1}{2}$ ".

**NOTE** ▶ A shingle mold may be placed at the top of the fascia if desired.

D. Nail fascia in place using two galvanized 8d casing nails spaced approximately every 16". See Figure 94.

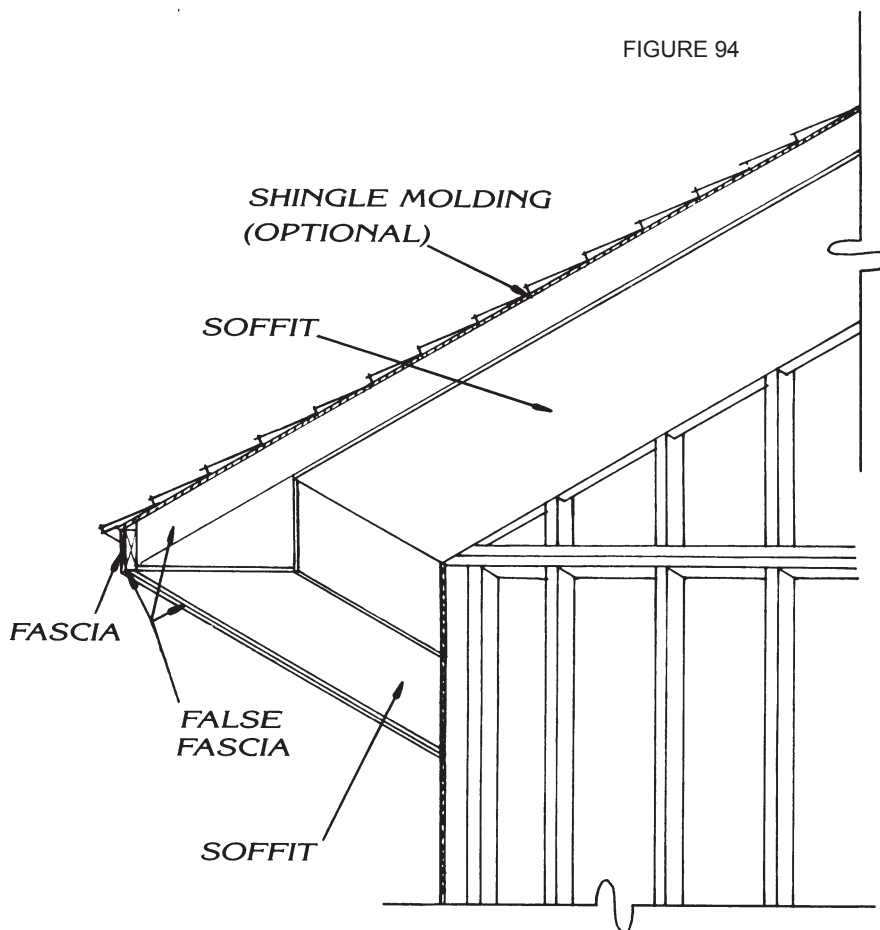



Yes No

6. Install the frieze.



A. For wood siding.

1) Install siding before installing frieze.

**NOTE ►** See Job Sheet #2.

2) Place frieze in the corner that is formed where the soffit meets the siding.

3) Nail the frieze in place, using 8d casing nails.



B. For brick veneer

**NOTE ►** The frieze may be made by ripping strips from 1-inch lumber as specified.

1) Measure 5" out from sheathing on soffit plus the thickness of the frieze board and make a mark at each corner of structure.

**NOTE ►** This spacing is for common brick. The spacing will vary with brick size.

2) Snap a chalk line between the marks on the bottom side of the soffit.

**NOTE ►** This spacing is for common brick. The spacing will vary with brick size.

3) Nail the frieze to 1 x 4 blocking, using 8d galvanized casing nails, using masonry fasteners.

**NOTE ►** To keep from splitting the frieze, drill a hole through the frieze at each nail location. All splices should be on a lookout.



7. Finish boxing in the end of eave. See Figure 95.



8. Have your instructor check your work.



9. Clean up the area and put away the equipment and supplies.

FIGURE 95

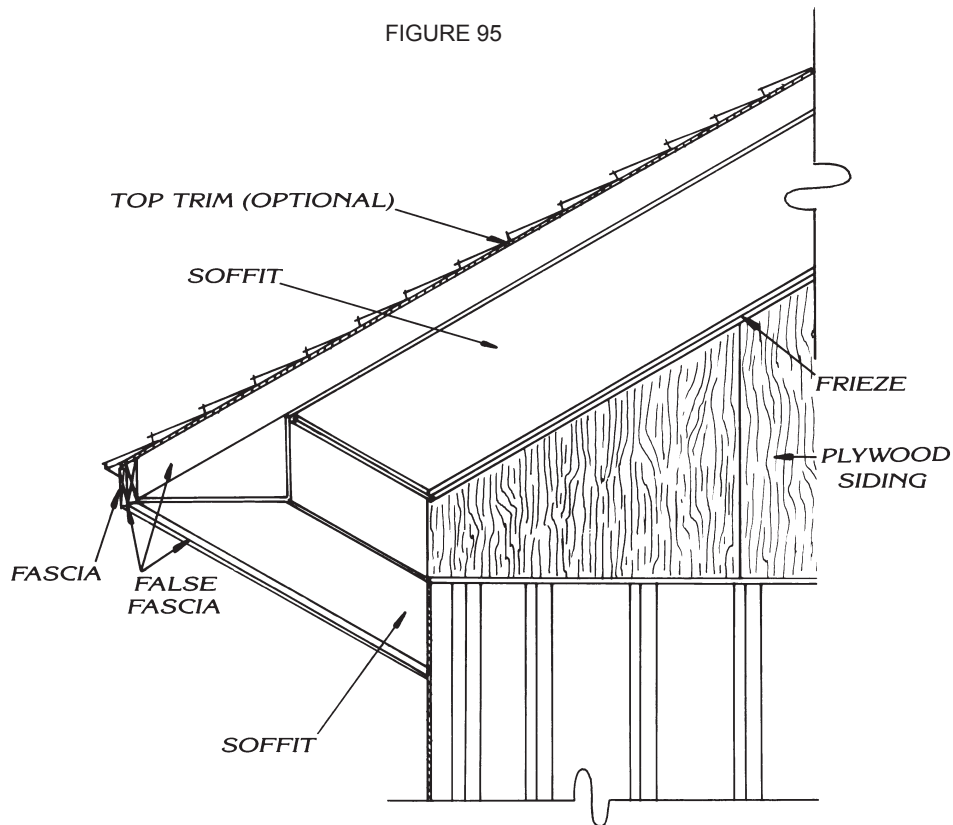

## PRODUCT EVALUATION

### SKILL TEST RECORD

**Evaluator note:** Rate the student on the following criteria by circling the appropriate numbers. Each criterion must receive a rating of "3" or higher to demonstrate student mastery. (See Key below.) A student who is unable to demonstrate mastery should review the material and submit another product for evaluation.

Criteria:

Length of lookouts ( $\frac{1}{4}$ "	4	3	2	1
Fascia miter cut ( $\frac{1}{4}$ "	4	3	2	1
Fascia below soffit ( $\frac{1}{8}$ "	4	3	2	1
Soffit width ( $\frac{1}{8}$ "	4	3	2	1
Placement of soffit ( $\frac{1}{4}$ "	4	3	2	1



## AVERAGE RATING

**Evaluator note:** To obtain an average rating for the Profile of Training Mastery, total the points in Product Evaluation and divide by the total number of criteria. Circle the rating on the Key.

## KEY

- 4 Skilled** — Can perform job with no additional training
- 3 Moderately Skilled** — Has performed job during training program; limited additional training may be required
- 2 Limited Skill** — Has performed job during training program; additional training is required to develop skill
- 1 Unskilled** — Is familiar with process, but is unable to perform job

## EVALUATOR'S COMMENTS

---

---

---



Student Name: \_\_\_\_\_ Score: \_\_\_\_\_

**APPLY SIDING TO GABLE END.**

**BASIC SKILLS**



**INTRODUCTION**

When applying siding to the gable end of a roof it is important to provide a stable surface that will lend support to the siding. Plywood is often used for this purpose. As with the box cornice the thickness and width of the plywood will determine the type and sizes of nails as well as nail spacing.

**EQUIPMENT AND SUPPLIES**

- 4' x 8' x ½" plywood siding
- 4' level
- Chalk line
- Claw hammer
- Framing square
- Galvanized or aluminum 6d box nails
- Hand saw
- One pair of sawhorses
- Pencil
- Personal protective equipment
- Power hand saw and extension cord
- Steel tape
- Two 6' scaffold sections with adjustable legs

## PROCEDURE

Yes No

- 1. Put on personal protective equipment.
- 2. Measure from the peak of the gable to the point where the bottom of the siding will be to establish the length of the plywood at this point. See Figure 96.

FIGURE 96

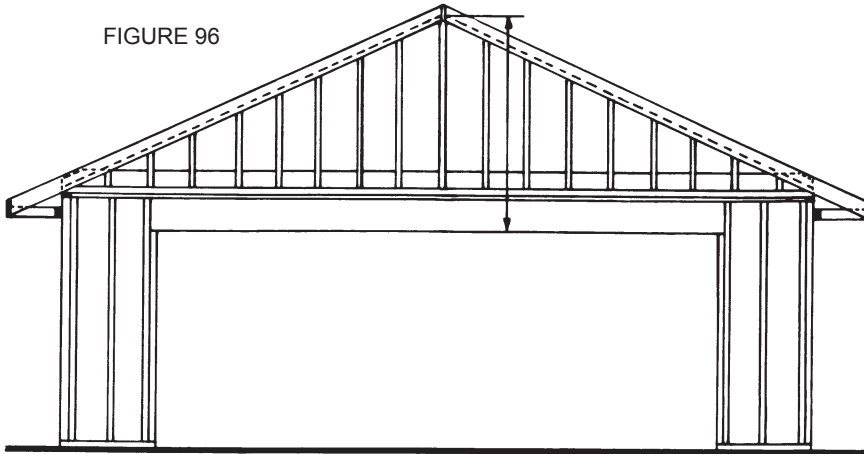

- 3. Lay the plywood face down on the sawhorses.
- 4. Transfer the gable measurement to the plywood by measuring from the bottom of the right side of the plywood up to the distance that you measured on the gable.
- 5. From the center of the gable, measure 4' to the right along the established bottom of the siding. See Figure 97.

FIGURE 97

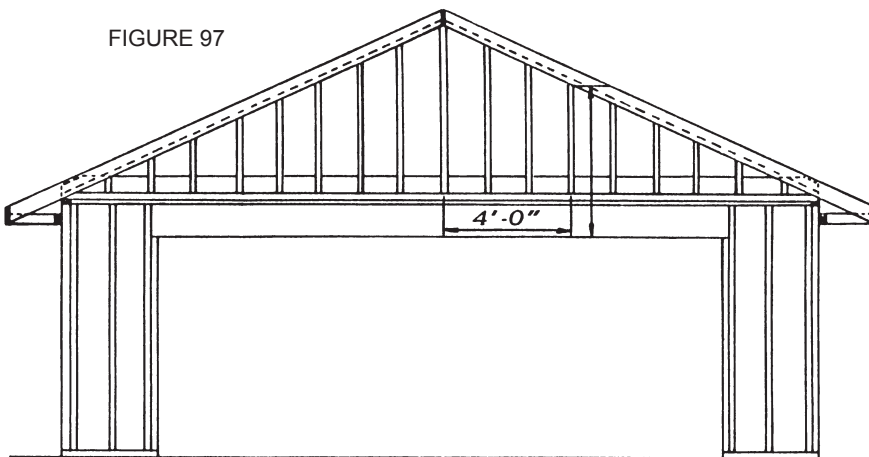



- ❑ ❑ 6. From the 4" point at the established bottom of the siding, measure to the top of the gable to establish length plywood should be at this point.
- ❑ ❑ 7. Transfer the gable measurement to the left side of the plywood.
- ❑ ❑ 8. Using a straightedge or chalk line, mark the cutting line on the plywood between the determined points at the top of the plywood.

**NOTE ►** This line establishes the angle from which all the siding for this gable should be cut.

- ❑ ❑ 9. Cut the plywood along the established line.
- ❑ ❑ 10. Check the fit of the plywood.
- ❑ ❑ 11. Nail the plywood in place with galvanized or aluminum nails. See Figure 98.

**NOTE ►** Be sure the edge of the plywood is plumb before nailing completely.

FIGURE 98

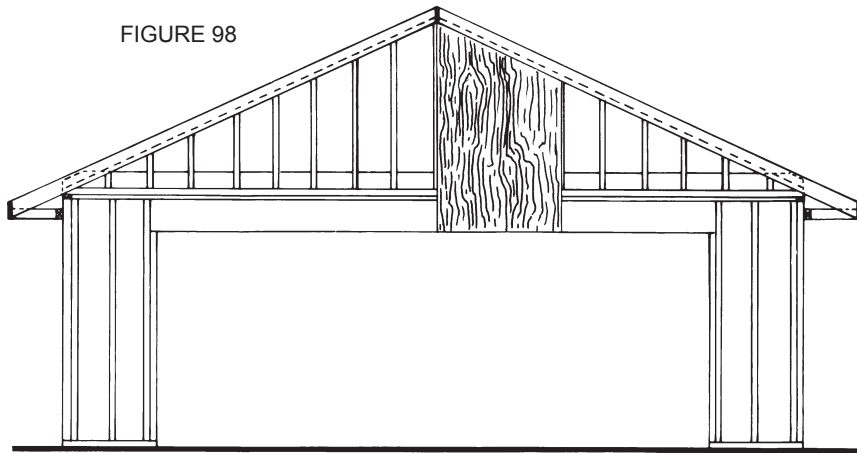

- ❑ ❑ 12. Measure and cut the piece of plywood to fit the right of the first piece.  
**NOTE ►** The cut-off piece should be large enough to use for the last piece on the right.
- ❑ ❑ 13. Continue the procedure until all of the siding on the right side of the gable has been applied.
- ❑ ❑ 14. Follow steps 2 through 13 to apply siding to the left side of the gable. See Figure 99.



FIGURE 99

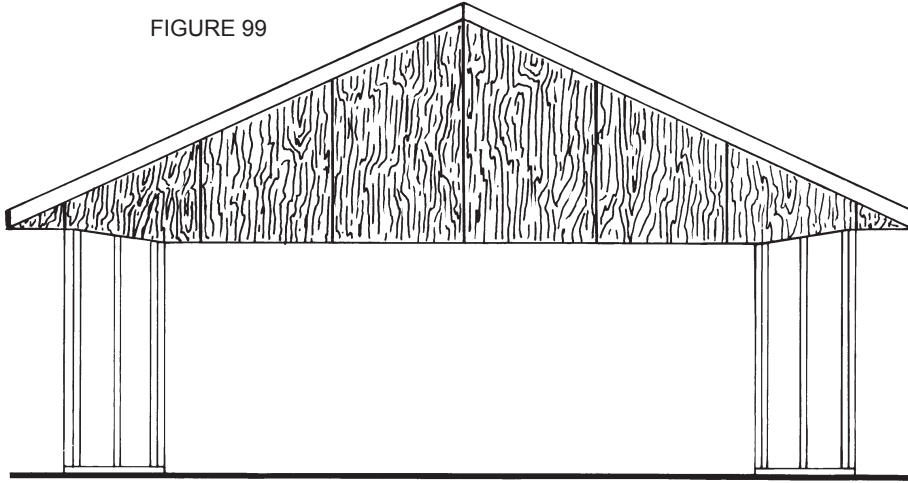

- 15. Have your instructor check your work.
- 16. Clean up the area and put away the equipment and supplies.

## PRODUCT EVALUATION

### SKILL TEST RECORD

**Evaluator note:** Rate the student on the following criteria by circling the appropriate numbers. Each criterion must receive a rating of “3” or higher to demonstrate student mastery. (See Key below.) A student who is unable to demonstrate mastery should review the material and submit another product for evaluation.

Criteria:

Siding in proper position ( $\frac{1}{4}$ "	4	3	2	1
Plywood cut to size ( $\frac{1}{4}$ "	4	3	2	1
Proper mails used	4	3	2	1
Plywood plumb ( $\frac{1}{16}$ "	4	3	2	1



## AVERAGE RATING

**Evaluator note:** To obtain an average rating for the Profile of Training Mastery, total the points in Product Evaluation and divide by the total number of criteria. Circle the rating on the Key.

## KEY

- 4 Skilled** — Can perform job with no additional training
- 3 Moderately Skilled** — Has performed job during training program; limited additional training may be required
- 2 Limited Skill** — Has performed job during training program; additional training is required to develop skill
- 1 Unskilled** — Is familiar with process, but is unable to perform job

## EVALUATOR'S COMMENTS

---

---

---



# **EXTERIOR WALLS AND TRIM**

## **CARPENTRY SERIES**



EXTERIOR WALLS AND TRIM  
CARPENTRY SERIES  
**JOB SHEET**

1

Student Name: \_\_\_\_\_ Score: \_\_\_\_\_

**INSTALL FIBERBOARD OR INSULATION-PANEL, GYPSUM-BOARD, AND PLYWOOD SHEATHING.**

**BASIC SKILLS**



**INTRODUCTION**

Sheathing is the inner layer of the outside wall covering on a frame structure that forms a flat layer base upon which the siding or other material is applied. The sheathing adds strength and usually rigidity to the house. However, some sheathing may require bracing if the material is not rigid enough.

The most common types of sheathing are fiberboard, insulation-panel, gypsum board, and plywood. Plywood sheathing is used to cover large areas fast while adding strength and rigidity to the structure. Plywood holds nails well and provides a solid nailing base for the finish material. Plywood comes in 4 x 8 sheets and is applied vertically or horizontally. When applied horizontally, it will require diagonal corner bracing in the wall framework. The building plans will specify which method should be used to apply the sheathing.

Gypsum sheathing is composed of treated gypsum filler faced on both sides with lightweight paper. Gypsum comes in 2 x 8 or 4 x 8 sheets and is applied horizontally. The gypsum sheathing may be edged with a tongue and groove finish to ease in its application.

Wall sheathing may be applied at any one of three stages; when the wall is lying on the sub floor, completely framed and squared or when the wall and ceiling frames have been erected, plumbed, and braced. Most carpenters will apply the sheathing as quickly as possible to add strength and provide a solid surface for the ceiling members.

## EQUIPMENT AND SUPPLIES

- 11 x 4s for diagonal braces
- 1½" barbed roofing nails for gypsum board
- 2" ring shank roofing nails for fiberboard
- 6d box nail for plywood
- 8d box nail for braces
- Chalk line
- Circular saw
- Claw hammer
- Extension cord
- Framing square
- Fiberboard
- Gypsum-board (Gyplap)
- Personal protective equipment
- Plywood
- Straightedge
- Steel tape

## PROCEDURE 1

### Install fiberboard or insulation-panel sheathing with plywood corner bracing

**NOTE** ► Follow manufacturer's recommendations for nailing, joints, and installation.

Yes No

- |                          |                          |  |
|--------------------------|--------------------------|--|
| <input type="checkbox"/> | <input type="checkbox"/> | 1. Put on all personal protective equipment.   |
|                          |                          | 2. Apply a full sheet of plywood to each exterior corner of the structure.   |
| <input type="checkbox"/> | <input type="checkbox"/> | A. Chalk a line vertically on the sheathing at each stud.  |
| <input type="checkbox"/> | <input type="checkbox"/> | B. Start at the bottom of the corner of one wall and tack the panel in place.  |
| <input type="checkbox"/> | <input type="checkbox"/> | C. Complete the nailing.   |
|                          |                          | <b>NOTE</b> ► Space the nails 6" on the center of edges and 12" on the center for each stud.                                 |
| <input type="checkbox"/> | <input type="checkbox"/> | D. Continue the procedure, lapping the edges of the plywood at the corners until all the plywood bracing has been installed. |





3. Apply the sheathing. See Figure 100.

**NOTE** ▶ Be sure to apply sheathing according to local building codes.

FIGURE 100

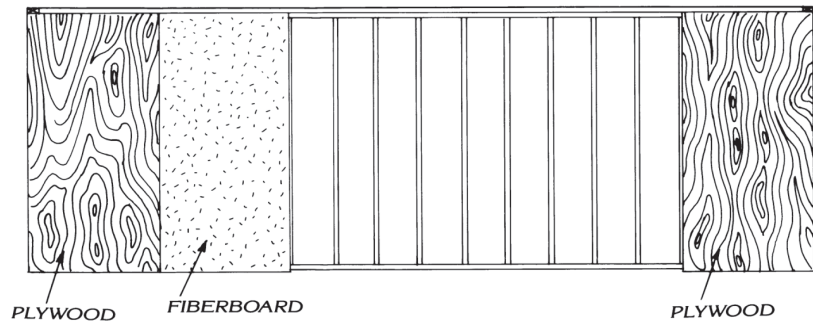

**Yes** **No**

A. Chalk the lines vertically on the sheathing at each stud.

B. Tack the panels in place.

C. Complete the nailing.

**NOTE** ▶ Space the nails 3" inches on the center at the edges and 6" on the center at each stud.

4. Have your instructor check your work.

5. Clean up the area and put away the equipment and supplies.

## PROCEDURE 2

### Installation of gypsum-board sheathing with metal diagonal bracing

**Yes** **No**

1. Put on all personal protective equipment.

2. Starting at the bottom of the corner of one wall tack the panel in place with the topside up. See Figure 101.

3. Complete the nailing procedures as described above.

**NOTE** ▶ Nail as required for the type of exterior finish to be used.



Yes No

- Continue the installation, working up from the bottom and staggering the joints. See Figure 101.

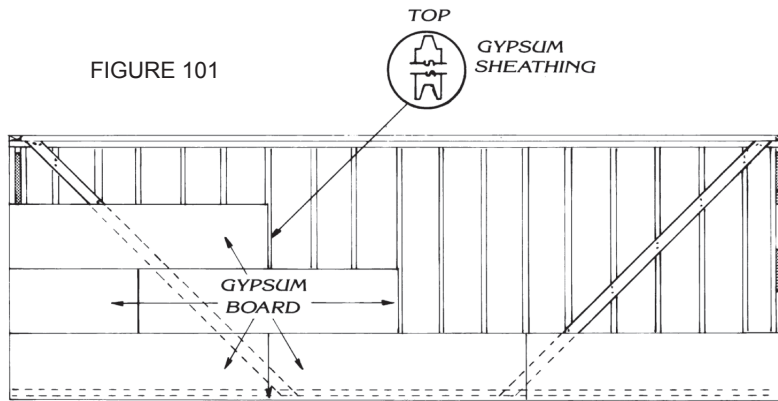

- Have your instructor check your work.

- Clean up the area and put away the equipment and supplies.

## PROCEDURE 3

### Installation of plywood sheathing

Yes No

- Put on all personal protective equipment.

- Install a plywood panel at each corner for bracing. See Figure 102.

**NOTE** ► Be sure to apply sheathing according to local building codes.

- Install intermediate panels.

FIGURE 102

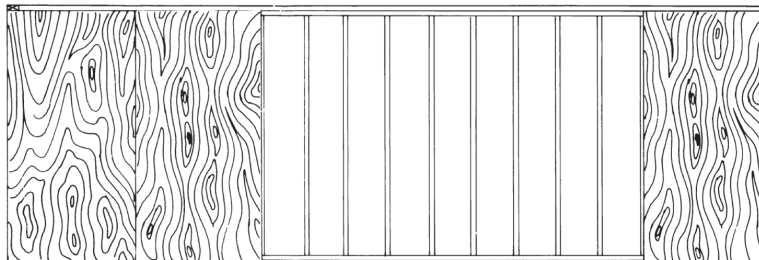

Yes No

4. Have your instructor check your work.

5. Clean up the area and put away the equipment and supplies.

## PRODUCT EVALUATION

### SKILL TEST RECORD

**Evaluator note:** Rate the student on the following criteria by circling the appropriate numbers. Each criterion must receive a rating of "3" or higher to demonstrate student mastery. (See Key below.) A student who is unable to demonstrate mastery should review the material and submit another product for evaluation.

Criteria:

Nail spacing for plywood corners $\frac{1}{4}$ "	4	3	2	1
Nail spacing for sheathing $\frac{1}{4}$ "	4	3	2	1
Sheathing attached soundly	4	3	2	1
Gypsum-board staggered	4	3	2	1

### AVERAGE RATING

**Evaluator note:** To obtain an average rating for the Profile of Training Mastery, total the points in Product Evaluation and divide by the total number of criteria. Circle the rating on the Key.

### KEY

**4 Skilled** — Can perform job with no additional training

**3 Moderately Skilled** — Has performed job during training program; limited additional training may be required

**2 Limited Skill** — Has performed job during training program; additional training is required to develop skill

**1 Unskilled** — Is familiar with process, but is unable to perform job

## EVALUATOR'S COMMENTS

---

---

---



Student Name: \_\_\_\_\_ Score: \_\_\_\_\_

**INSTALL BEVEL SIDING.**

**BASIC SKILLS**



READING



MATHEMATICS



CRITICAL  
THINKING



EMPLOYABILITY

**INTRODUCTION**

To begin installing bevel siding, it is important to carefully lay out the siding. In planning the installation, be sure to plan a course of siding to run across the top of the window in alignment with the window cap. Bevel siding may be started at the foundation or on a water table projecting from the foundation. The first course of siding determines the consistency of the level for the next course. Each course of bevel siding must overlap the previous course and fit firmly. When nailing bevel siding, be sure to use good nailing practices. Use 8d siding nails for  $\frac{3}{4}$ " thickness and 6d nails for smaller thickness. Use only one nail per bearing and never nail through both courses of siding. Tap the nail head flush with the siding.

**Words You Should Know**

**Story pole**

a pole or board that is graduated along its length and used for repetitious measurements

## EQUIPMENT AND SUPPLIES

- 1 x 4s for outside corners
- 6" bevel siding
- 48" and 72" levels
- Building paper for underlayment
- Caulking gun and caulking
- Chalk line
- Circular saw and extension cord
- Claw hammer
- Combination square
- Drip caps
- Flashing for windows and doors
- Framing square
- Furring strips for spacer under bottom piece of siding
- Handsaw
- Nails (as specified)
- Personal protective equipment
- Radial arm saw or table saw
- Spacing jig
- Steel tape

## PROCEDURE

Yes No

- |                          |                          |  |
|--------------------------|--------------------------|--|
| <input type="checkbox"/> | <input type="checkbox"/> | 1. Put on personal protective equipment.               |
| <input type="checkbox"/> | <input type="checkbox"/> | 2. Start at one corner and work around the building.   |
| <input type="checkbox"/> | <input type="checkbox"/> | 3. Apply underlayment.                                 |
| <input type="checkbox"/> | <input type="checkbox"/> | 4. Install outside corner trim boards. See Figure 103. |

**NOTE** ► The bottom of the trim boards should extend 1" below the bottom of the sheathing.

FIGURE 103

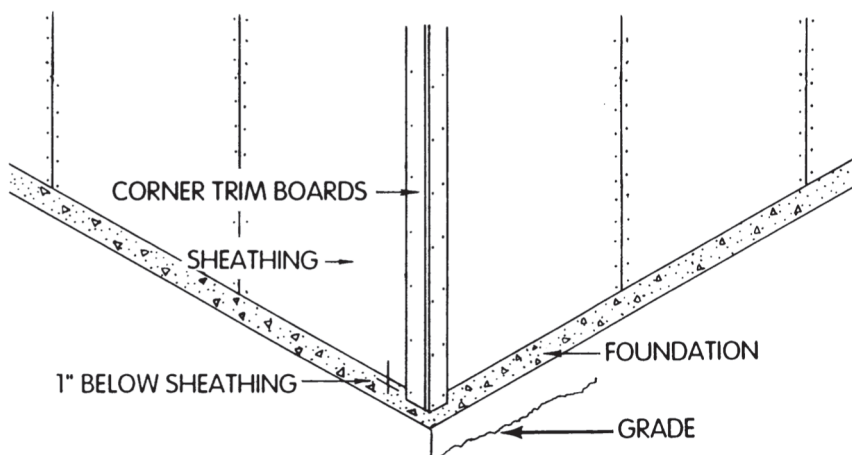



Yes No

5. Determine the actual exposure.

A. Measure the overall height of the wall.

B. Divide by the desired exposure of each row.

C. Round to the nearest whole number.

D. Divide overall height by the number of rows to determine the actual exposure. See Figure 104.

**NOTE** ► Some carpenters prefer to space bevel siding to allow for the continuous pieces over the openings. A story pole is used and aligned with the headers before marking the siding layout.

FIGURE 104

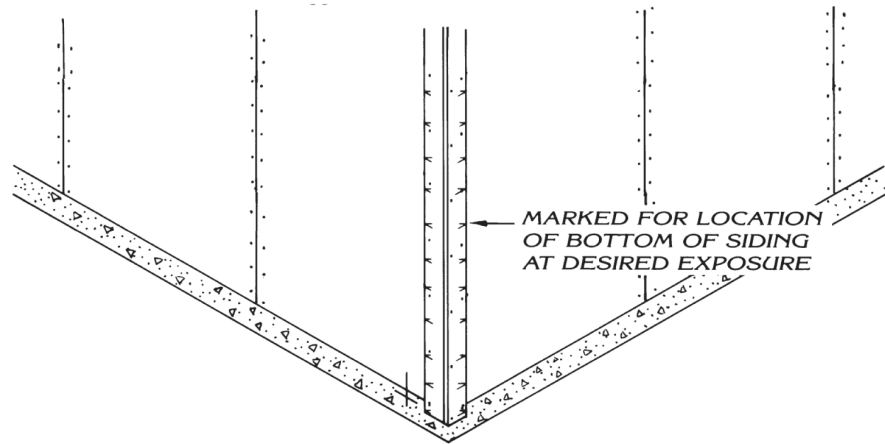

6. Snap a chalk line on the sheathing at the top of the furring strip location.

7. Cut a furring strip the thickness of the top edge of the siding being used and nail to the bottom of the wall. See Figure 105.

**NOTE** ► This procedure is done only on the drop siding.

FIGURE 105

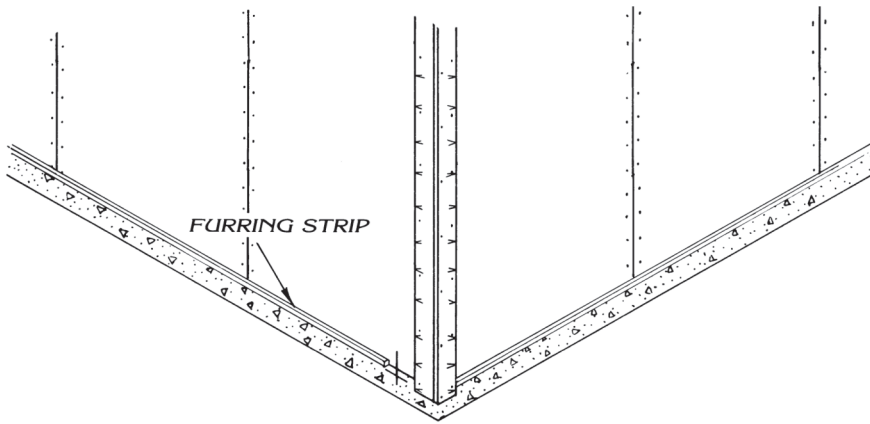

Yes No



8. Start the siding at the corner and work around. See Figure 106.

**NOTE** ▶ Leave 1/8" gap between corner board and edge of siding. This should be applied at windows and doors trim boards as well.

FIGURE 106

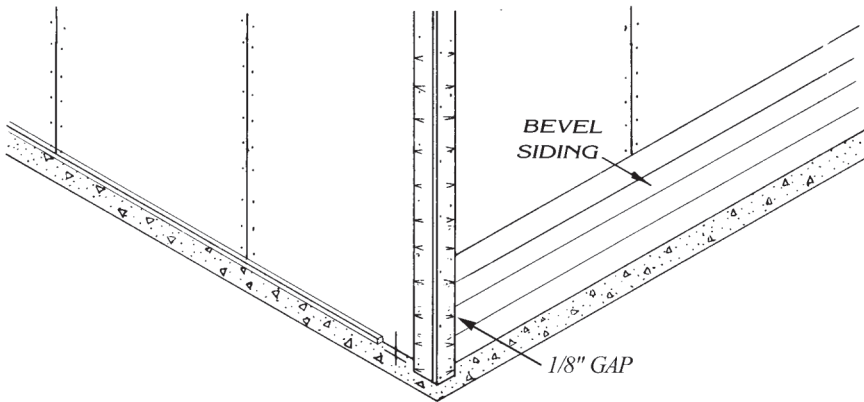

9. Use the spacing jig (preacher) for spacing siding between the corners (vertical spacing). See Figure 107.





FIGURE 107

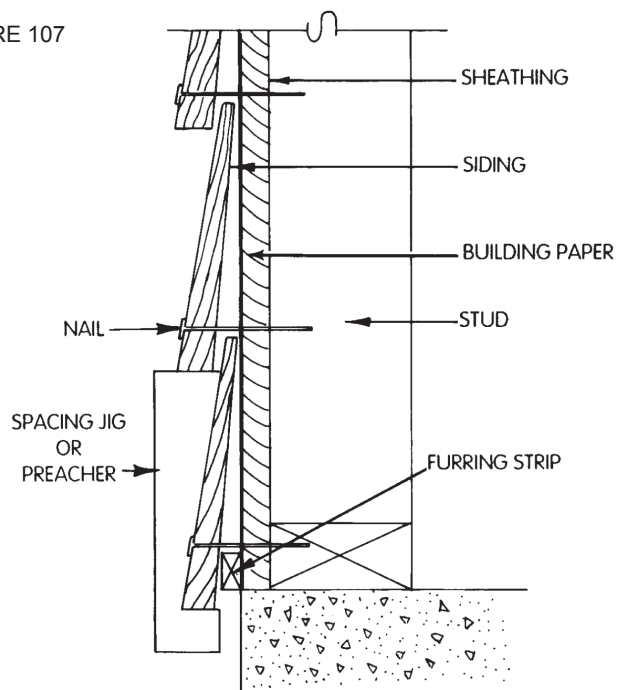

Yes No

- 10. Continue the procedure to install the remaining siding, keeping the joints tight, and making all the splices on a stud.

**NOTE** ▶ Tight fitting butt joints are made by cutting the closure board of each cause slightly longer than needed. Loose fitting joints allows water to get behind the siding causing decay and failure of the boards.

- 11. Install the drip caps above the windows and doors.
- 12. Install the flashing over the windows and doors.
- 13. Trim the windows and doors. See Figure 108.

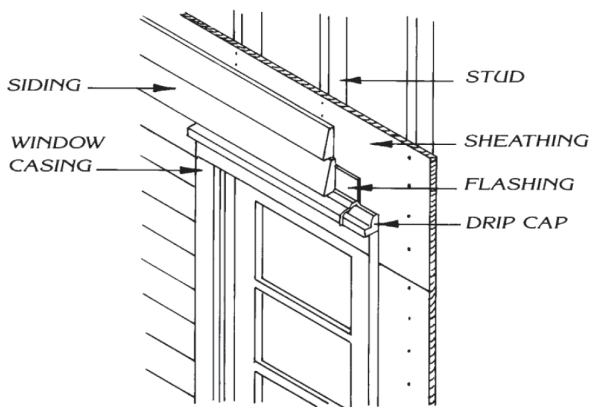

FIGURE 108



Yes No

14. Caulk all the joints around the windows, doors, and corners.
15. Have your instructor check your work.
16. Clean up the area and put away the equipment and supplies.

## PRODUCT EVALUATION

### SKILL TEST RECORD

**Evaluator note:** Rate the student on the following criteria by circling the appropriate numbers. Each criterion must receive a rating of “3” or higher to demonstrate student mastery. (See Key below.) A student who is unable to demonstrate mastery should review the material and submit another product for evaluation.

Criteria:

Trim board position ( $\frac{1}{8}$ "	4	3	2	1
Exposure measurement ( $\frac{1}{4}$ "	4	3	2	1
Furring strips at proper location ( $\frac{1}{8}$ "	4	3	2	1
Siding joints tight ( $\frac{1}{8}$ "	4	3	2	1
Caulking complete and smooth	4	3	2	1

### AVERAGE RATING

**Evaluator note:** To obtain an average rating for the Profile of Training Mastery, total the points in Product Evaluation and divide by the total number of criteria. Circle the rating on the Key.





## KEY

- 4 **Skilled** — Can perform job with no additional training
- 3 **Moderately Skilled** — Has performed job during training program; limited additional training may be required
- 2 **Limited Skill** — Has performed job during training program; additional training is required to develop skill
- 1 **Unskilled** — Is familiar with process, but is unable to perform job

## EVALUATOR'S COMMENTS

---

---

---



Student Name: \_\_\_\_\_ Score: \_\_\_\_\_

**INSTALL SHEATHING AND PLYWOOD SIDING.****BASIC SKILLS****INTRODUCTION**

Plywood siding comes in many grades, textures, and designs giving a greater variety of choices to the builder and architect. It is commonly applied vertically but it may be applied horizontally. However, all the edges of the panel siding should be backed with framing members. In addition, galvanized, aluminum, or other non-corrosive nails should be used to attach it to the framing members or blocking. It may have with flush joints, V-grooves, or other end treatments.

**EQUIPMENT AND SUPPLIES**

- 4 x 8 exterior plywood siding
- 4 x 8 fiberboard sheathing (insulation board)
- 6d and 8d galvanized box nails
- 48" level and straightedge
- Building paper for underlayment (vapor barrier)
- Caulking gun and caulking
- Chalk line
- Circular saw
- Claw hammer
- Extension cord
- Framing square

- Handsaw
- Personal protective equipment
- Sawhorses
- Staples or T-nails
- Steel tape

## PROCEDURE

Yes No

- 1. Put on all personal protective equipment.
- 2. Check the corner for plumb, as it may be necessary to scribe and cut the first sheet of sheathing and siding. See Figure 109.

**NOTE** ▶ Use a level, as in Figure 109, or a plumb bob to check for plumb.

FIGURE 109

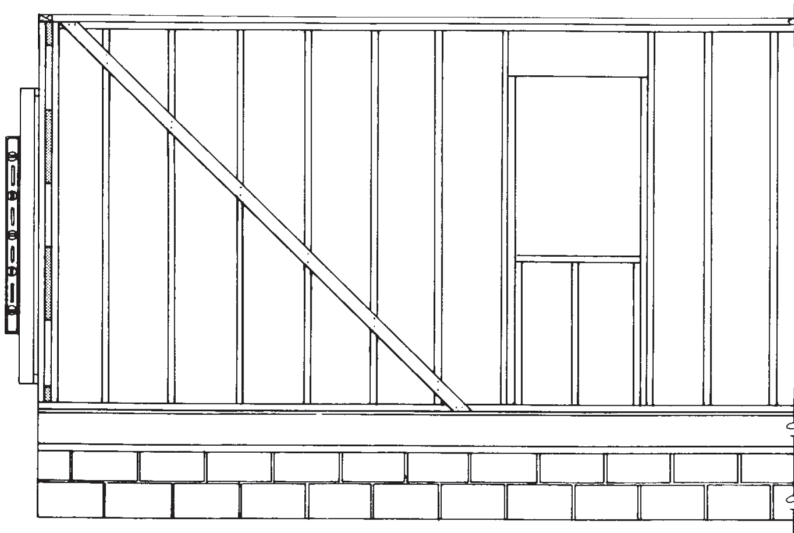

- 3. Install a 32" wide sheet of sheathing (fiber board) or insulation board at the corner.  
**NOTE** ▶ This narrow piece is necessary to avoid having the joints of the sheathing and siding on the same stud. If the plywood bracing is used, install a 32" wide sheet of siding as the first piece of siding.
- 4. Nail the first piece of sheathing in place.





Yes No

5. Cut and install a band of sheathing to cover the rim joist if necessary. See Figure 110.

FIGURE 110

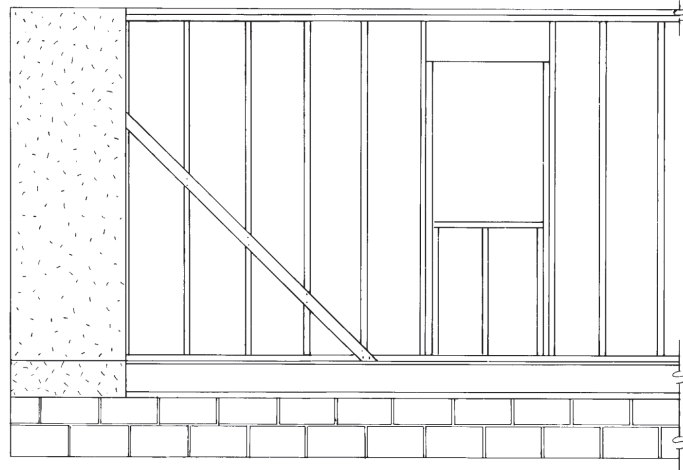

6. Finish installing the sheathing on the structure.

7. Install the underlayment (vapor barrier).

8. Plumb and install the first sheet of siding. See Figure 111.

**NOTE** ▶ Space the nails every 6" on the edges and every 12" on intermediate studs. Place the nails about  $\frac{3}{8}$ " from the edge of the panels. Cut the siding from the unfinished side. When the corner trim is used, it may not be necessary to scribe and cut the siding.

FIGURE 111

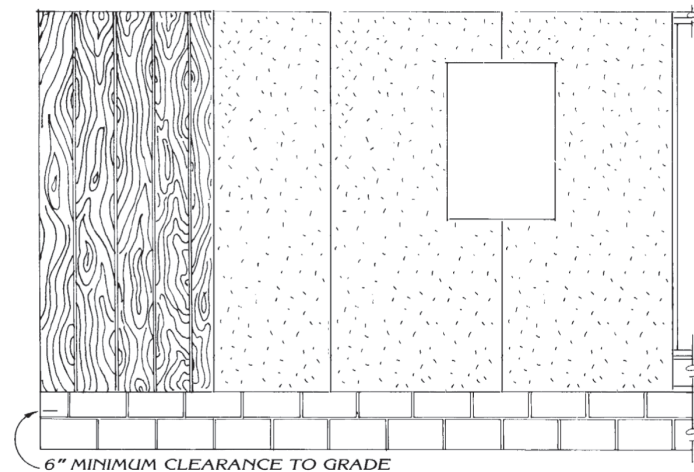

Yes No

- 9. Continue installing the sheathing and siding, leaving manufacturer's recommended spacing at all edges and ends of siding for the shrinkage. See Figure 112.
- 10. Caulk all of the vertical joints.

**NOTE** ▶ When installing the horizontal siding, use the flashing and caulking. Z flashing is recommended.

FIGURE 112

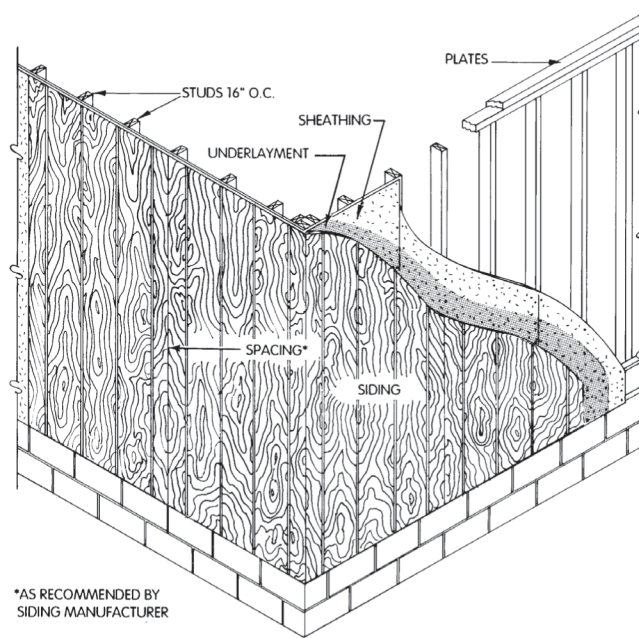
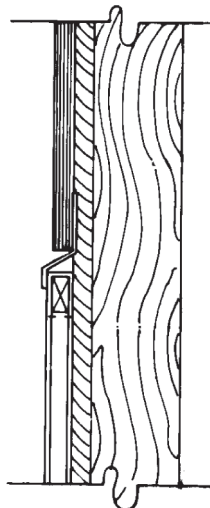

FIGURE 113

- 11. Install flashing over windows and doors. See Figure 113.





Yes No

- 12. Caulk over the window and doors. See Figure 114.
- 13. Continue fitting and nailing until siding is completed. See Figure 115.
- 14. Have your instructor check your work.
- 15. Clean up the area and put away the equipment and supplies.

FIGURE 114

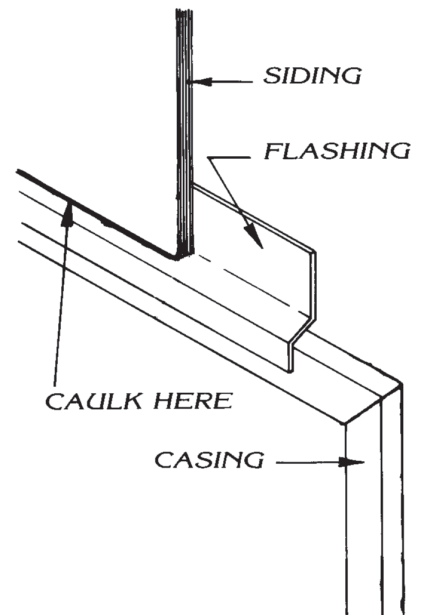
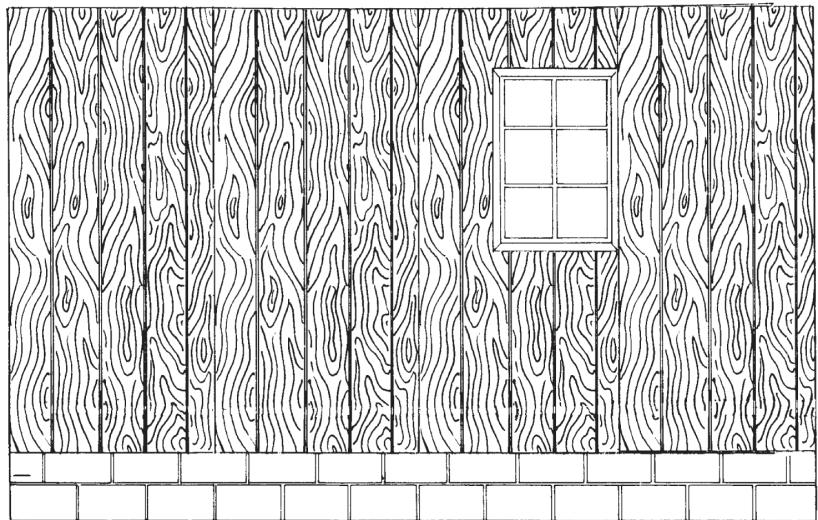

FIGURE 115





# PRODUCT EVALUATION

## SKILL TEST RECORD

**Evaluator note:** Rate the student on the following criteria by circling the appropriate numbers. Each criterion must receive a rating of “3” or higher to demonstrate student mastery. (See Key below.) A student who is unable to demonstrate mastery should review the material and submit another product for evaluation.

Criteria:

Corners are plumb ( $\frac{1}{8}$ "	4	3	2	1
First sheet of sheathing is 32"	4	3	2	1
Underlayment installed	4	3	2	1
Nail spacing in side panels correct ( $\frac{1}{4}$ "	4	3	2	1
Correct spacing of siding panels and sheathing ( $\frac{1}{32}$ "	4	3	2	1

## AVERAGE RATING

**Evaluator note:** To obtain an average rating for the Profile of Training Mastery, total the points in Product Evaluation and divide by the total number of criteria. Circle the rating on the Key.

## KEY

- 4 Skilled** — Can perform job with no additional training
- 3 Moderately Skilled** — Has performed job during training program; limited additional training may be required
- 2 Limited Skill** — Has performed job during training program; additional training is required to develop skill
- 1 Unskilled** — Is familiar with process, but is unable to perform job





## EVALUATOR'S COMMENTS

---

---

---



Student Name: \_\_\_\_\_ Score: \_\_\_\_\_

**INSTALL VINYL SIDING.**

**BASIC SKILLS**



**INTRODUCTION**

A flat, level wall surface is necessary for proper installation of vinyl siding. Flashing should be installed before installing siding. It is recommended that a weather-protection barrier, such as house wrap or felt paper be applied to the house as well. When residing a building be sure to nail down loose boards and replace any rotten ones. Never install vinyl siding over rotting wood.

**EQUIPMENT AND SUPPLIES**

- 16d box nails
- 25' tape with markings at 16" centers
- Chalk line
- Circular saw with plywood blade reversed
- Framing hammer
- Framing square or speed square
- Hammer
- Line level or 4' level
- Nails for hanging siding
- Nail hole punch
- Personal protective equipment

- Radial arm saw with fine tooth blade
- Snaplock tool
- Steel tape
- Tin snips
- Unlocking tool (zipper tool)
- Utility knife
- Vinyl siding and trim pieces

## PROCEDURE

Yes No

- |   |  |
|---|--|
| <input type="checkbox"/> <input type="checkbox"/> | 1. Put on personal protective equipment.   |
| 2. Install starter strip.                         |  |
| <input type="checkbox"/> <input type="checkbox"/> | A. Determine the lowest point of the wall that will be sided; from that point, measure up $\frac{1}{4}$ " less than the width of the starter strip and partially drive a nail at one corner.   |
| <input type="checkbox"/> <input type="checkbox"/> | B. Attach a chalk line to the nail and stretch the chalk line to the next corner. Make sure the line is level by using a line level or 4' level.   |
| <input type="checkbox"/> <input type="checkbox"/> | C. Snap the chalk line and repeat the procedure around the entire house.   |
| <input type="checkbox"/> <input type="checkbox"/> | D. Using the chalk line as a guide, install the top edge of the starter strip along the bottom of the chalk line, nailing at 10" intervals. Allow space for the corner posts, J-channels, etc. |
| <input type="checkbox"/> <input type="checkbox"/> | E. Keep the ends of the starter strips at least $\frac{1}{4}$ " apart to allow for expansion. See Figure 116.  |

**NOTE ►** If using metal starter strip, there is no need to leave a gap.

FIGURE 116

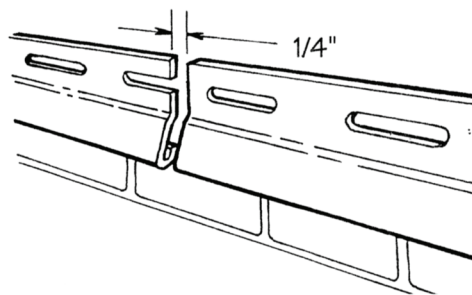



Yes No

F. Nail the starter strip in place by nailing in the center of the nailing slots.

3. Install outside and inside corner posts.

**NOTE** ► The corner post should extend  $\frac{3}{4}$ " below the starter strip.

A. Install a water resistant material to flash the inside and outside corners a minimum of 10" on each side before installation of corner posts. See Figure 117.

FIGURE 117

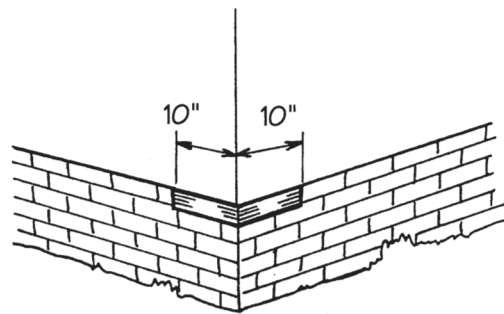

B. Place the corner post in position, allowing a  $\frac{1}{4}$ " gap between the top of the post and the eave or soffit.

C. Position a nail at the top of the upper slot on both sides of the corner post, leaving a  $\frac{1}{32}$ " gap between the nail heads and the corner posts. The corner post will hang from these nails. See Figures 118 and 119.

D. The balance of the nailing should be in the center of the slots, 8" to 12" apart.

FIGURE 118

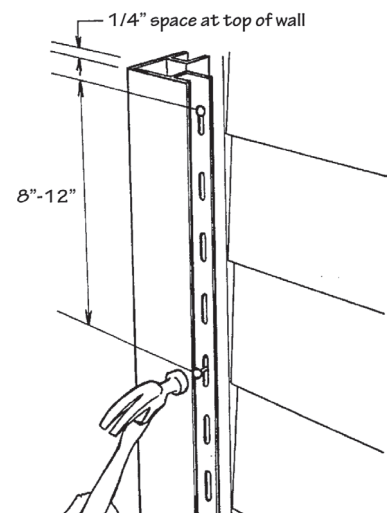
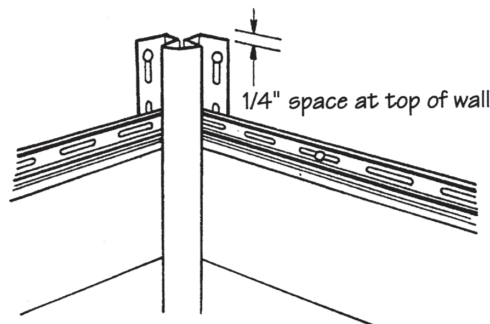

FIGURE 119



Yes No



E. Check corner post for plumb and vertical.

**NOTE** ▶ If more than one length of corner post is required, overlap the upper piece over the lower piece by cutting away 1" of the nailing flange on the top piece and overlap  $\frac{3}{4}$ ", allowing  $\frac{1}{4}$ " for expansion.

4. Install trim for openings.

**NOTE** ▶ J-channel is used around windows and doors to receive the siding. If vinyl windows are used, J-channel is optional.



A. Cut a J-channel for the bottom of the window, as wide as the frame, and install it.



B. Cut side J-channels the length of the frame plus the width of the top and bottom J-channel. Cut and bend tabs into the bottom channel. Install the side channels.



C. Cut the top J-channel the width of the frame plus the width of the side J-channels. Notch the top J-channel on each end, bend the tabs into the side J-channel, and fasten the top J-channel.



D. A miter cut and tab can be provided at the bottom of the window, depending on the sill's condition.

FIGURE 120a

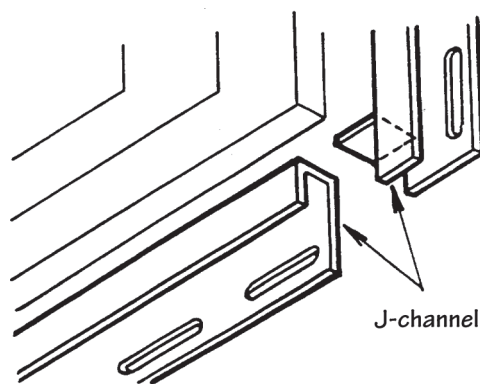
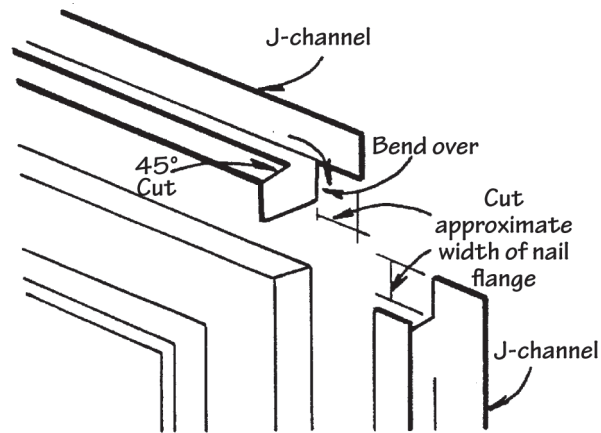



FIGURE 120b



Yes No

5. Install J-channel over roof lines.

A. Keep the J-channel a minimum of ½" from the roof line. Chalk a straight line up the roof flashing to guide J-channel installation.

B. Overlap the J-channel (lapping the upper piece over the lower piece) if it is necessary to use more than one piece.

C. Extend the J-channel past the edge of the roof, channeling water into the gutter, in order to ensure proper runoff.

**NOTE ►** Vinyl J-channel should not be in direct contact with roofing shingles since the shingles may transfer enough heat to the vinyl J-channel to cause its distortion. When using dark shingles or a south or west exposure it is recommended to either use a metal J-channel or to install the vinyl J-channel as far away from the roofing as aesthetically acceptable, having first ensured that there is sufficient flashing behind the J-channel to prevent water infiltration.

D. Fasten the nail, screw, or staple that is closest to the roof line at the far end of the nail hem slot, to ensure that siding will expand away from the J-channel. See Figure 121.



FIGURE 121

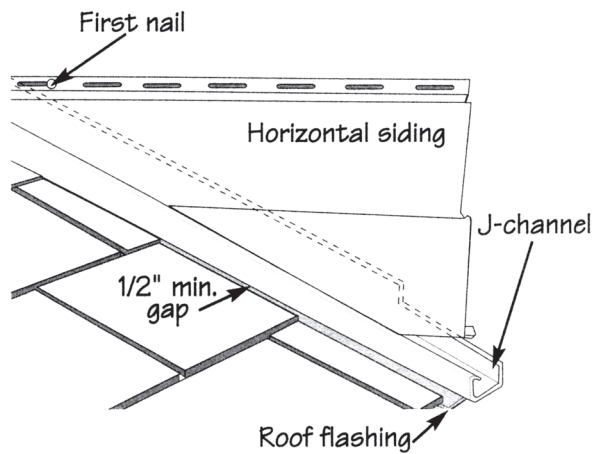

Yes No

6. Install horizontal siding.

A. Place the first course (row of panels) in the starter strip and securely lock along the entire length of the siding panel. Be sure the panel is securely locked before fastening.

B. Fasten the panels in the center of the nailing slots.

**NOTE** ► Allowance should be made for expansion and contraction by leaving a  $\frac{1}{4}$ " gap between the siding and all corner posts and channels. If installing in temperatures below 40°F increase the gap to  $\frac{3}{8}$ ". If the panels are 20 feet or longer, refer to the manufacturer's instructions for how to increase the gap. Do not force the panels up or down when fastening. Panel locks should be fully engaged; however, the panels should not be under vertical tension or compression when they are fastened.

C. Continue to install panels being sure to overlap by one half the length of the notch at the end of the panel, or approximately 1". (See Figure 122.) Be sure to check every fifth or sixth course (row of panels) for horizontal alignment and check siding alignment with adjoining walls.





FIGURE 122

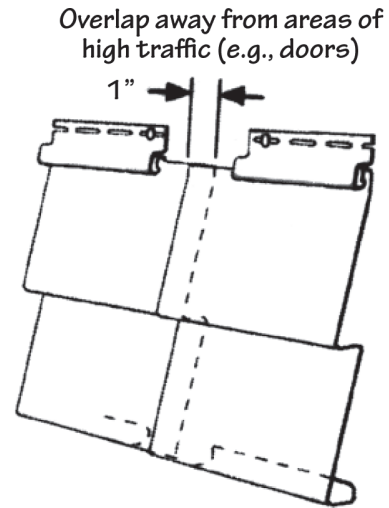

Yes No

**NOTE** ▶ Stagger the siding end laps so that no two courses (rows of panels) are aligned vertically, unless separated by at least three courses. Always overlap joints away from entrances and away from the greatest traffic to improve the overall appearance of the installation. See Figure 123.

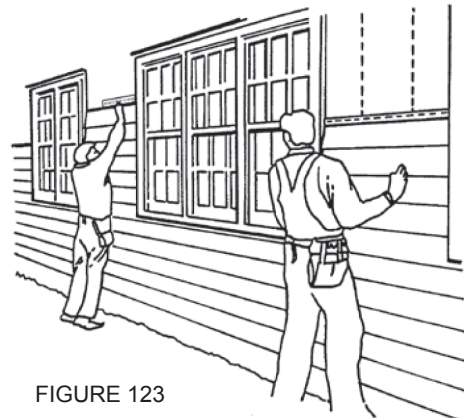

FIGURE 123

**NOTE** ▶ If hand-fitting to a fixture, always begin a new course of siding at the fixture. Cut a slot  $\frac{1}{4}$ " bigger than the fixture or the trim ring. Match the shape and contour of the fixture when cutting. See Figure 124.

Yes No

7. Fitting siding under windows.

A. Hold the panel under the window and mark the width of the window opening on the panel. Add approximately  $\frac{1}{4}$ " to both sides to allow for expansion and contraction of the siding. These marks represent the vertical cuts. See Figure 125.

FIGURE 124

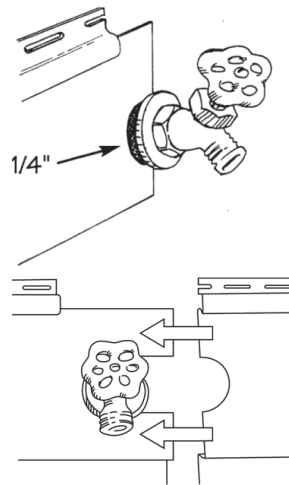

B. Lock a small piece of scrap siding into the lower panel next to the window. This will be used as a template for the horizontal cuts. Mark it  $\frac{1}{4}$ " below the sill height.

FIGURE 125

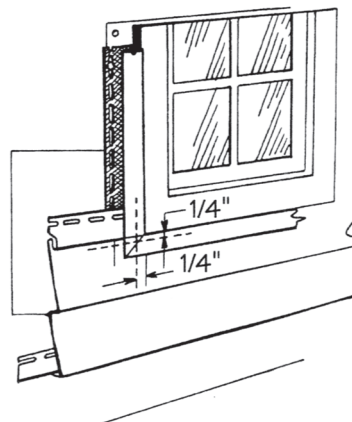

C. Transfer the horizontal measurement to the panel that will be installed under the window.

D. Cut the panel with tin snips and a utility knife.

E. Use a snap lock punch to place lugs along the cut edge of the panel every 6".

F. Install utility trim under the window, as a receiver for the cut siding. Utility trim is used any time the top lock has been removed from the siding. Furring may be needed to maintain the face of the panel at the desired angle.

G. Install the siding panel, making sure the lugs lock into the utility trim. See Figure 126.

FIGURE 126

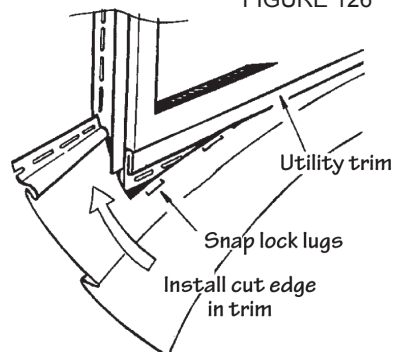



Yes No

8. Finishing gable ends.

**NOTE** ▶ Before the final course of siding is installed on the wall, any soffit accessories that will be used on the eaves must be installed.

A. Make a pattern that duplicates the slope of the gable. See Figure 127.

B. Lock a short piece of siding into the gable starter course (the last panel before the gable starts).

FIGURE 127

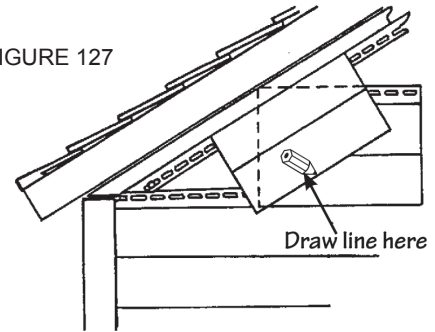

C. Hold a second piece of siding against the J-channel at the slope of the gable and mark the slope with a pencil on the short piece of siding. Check the angle template every few courses.

D. Remove the short piece and cut along the pencil line as a pattern for the gable angle cuts.

E. Repeat this procedure on the opposite side of the gable.

**NOTE** ▶ It may be necessary to fasten the last panel at the gable peak with a trim nail. Use a 1¼" to 1½" nail. This is one of the few times a nail should be placed in the face of the vinyl siding. See Figure 128.

Colored aluminum  
or stainless steel  
finish nail

FIGURE 128

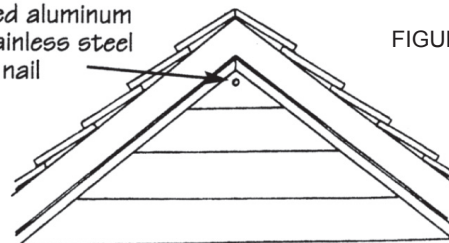

Yes No

9. Install eaves treatment.



A. Measure from the soffit to the base of the upper lock on the previous course of panels. Subtract  $\frac{1}{4}$ " and mark this dimension on the panel to be cut, measuring from the bottom edge of the panel. It is a good idea to check the dimension in several locations along the length of the wall. See Figure 129.



B. Using a snap lock punch, punch the vinyl siding along the cut edge every 6", so the raised lug is on the outside face.



C. Push the siding into the utility trim that has been nailed in place along the top of the wall. Furring may be needed to maintain the face of the panel at the desired angle. The raised lugs will catch and hold the siding firmly in place.

FIGURE 129

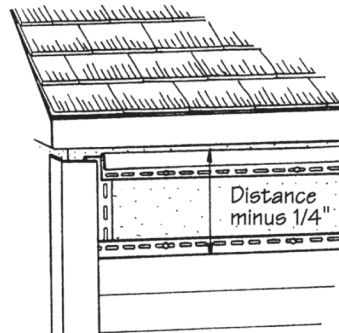

**NOTE** ► The last course of siding may be cut to fit the eaves opening.

10. Install soffit.

**NOTE** ► Soffit siding may be applied over an open eave or an enclosed eave. An open eave is an eave with an exposed rafter or truss and is typical of new construction. An enclosed eave already has soffit in place and is typical of residing projects.



A. Install receiving channels for an open eave per Figures 130 to 133 depending on the construction techniques used to create the eave. Nail channels every 8"-12", positioning the nail in the center of the slot. Do not nail tightly.





Yes No

FIGURE 130

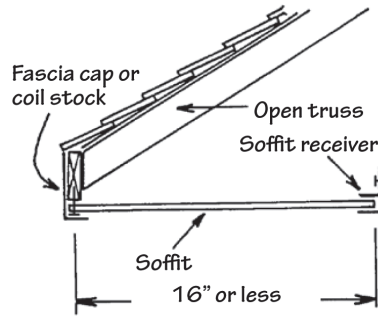

FIGURE 131

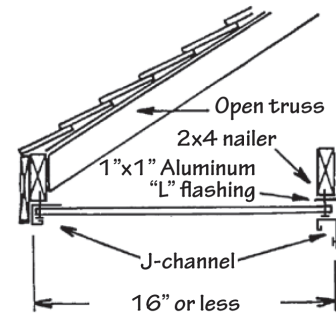

FIGURE 132

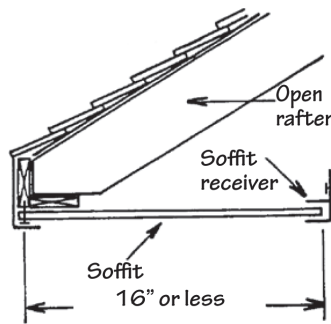

FIGURE 133

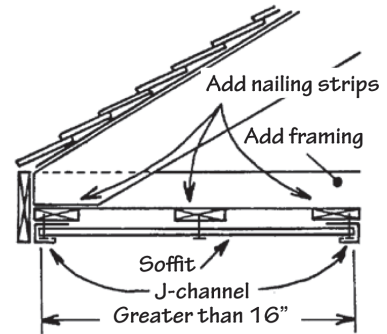

FIGURE 134

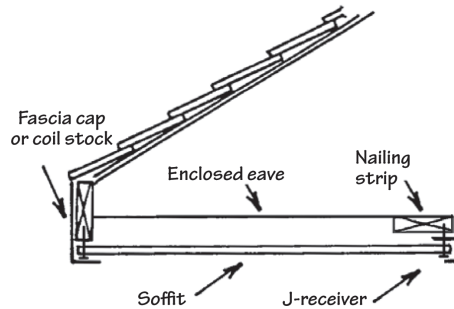
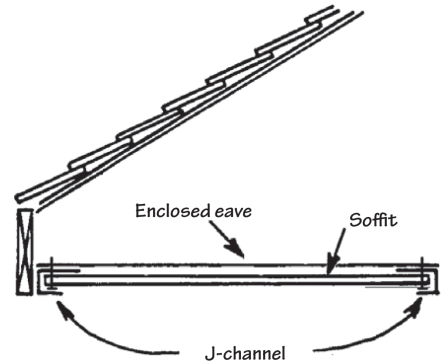

FIGURE 135



**NOTE** ▶ If no soffit receiver is available for a situation best suited for the product, the J-channel can be modified to create an F-receiver. See Figure 136. If the soffit will turn a corner, cut and install the channel so there is  $\frac{1}{4}$ " for expansion at each of the adjoining walls.

Yes No

11. Measure from the wall to the fascia board and subtract  $\frac{1}{2}$ " to allow for expansion.

FIGURE 136

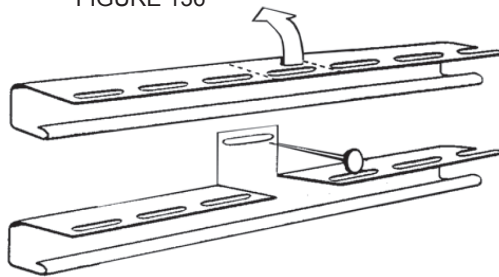

12. Mark and cut this dimension on a soffit panel. Cut one or two panels at the same time, carefully advancing the saw through the vinyl.

13. Insert the panel into the channel on the wall, then into the channel at the fascia board. See Figure 137.

**NOTE** ► If installing over an enclosed soffit be sure to align soffit vent panels with existing vent openings. If the existing soffit does not have vent openings, cut an adequate number of openings.

FIGURE 137

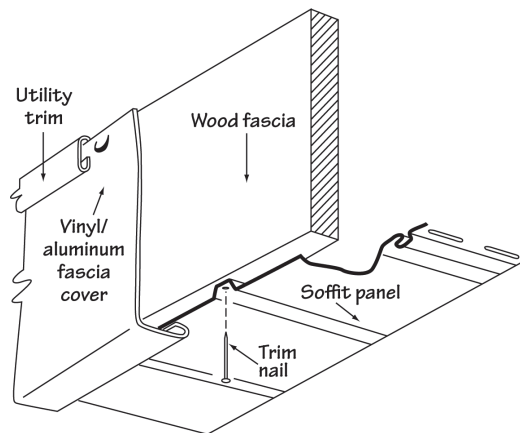

14. When turning a corner measure from the channel at the wall corner to the channel at the corner of the fascia board and subtract  $\frac{1}{4}$ " for expansion. See Figure 138.

FIGURE 138

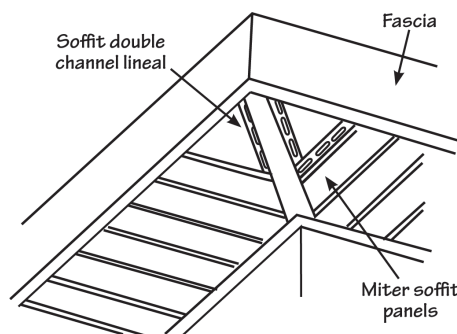



**Yes**   **No**

- 15. Cut and install soffit double channel lineal or back-to-back J-channel. If necessary install nailing strips to provide backing for the lineal.
  
- 16. Miter cut the corner soffit panels and install as in step 13.
  
- 17. To complete the installation, apply the utility trim and fasten the aluminum fascia cap or formed aluminum coil stock with painted trim nails. If necessary to face nail fascia, drill holes for the trim nails to allow for expansion and to reduce denting of the aluminum.
  
- 18. Clean up area and put away equipment and supplies.

Information and illustrations for this Job Sheet used with permission from the Vinyl Siding Institute, Inc. Look for the *Vinyl Siding Installation Manual* (updated December 2010) at [www.vinylsiding.org](http://www.vinylsiding.org).

## PRODUCT EVALUATION

### SKILL TEST RECORD

**Evaluator note:** Rate the student on the following criteria by circling the appropriate numbers. Each criterion must receive a rating of “3” or higher to demonstrate student mastery. (See Key below.) A student who is unable to demonstrate mastery should review the material and submit another product for evaluation.

Criteria:

Observed safety procedures	4	3	2	1
Left proper space for expansion and contraction	4	3	2	1
Panels installed level	4	3	2	1
Followed instructions	4	3	2	1
Provided satisfactory responses to questions asked	4	3	2	1



## AVERAGE RATING

**Evaluator note:** To obtain an average rating for the Profile of Training Mastery, total the points in Product Evaluation and divide by the total number of criteria. Circle the rating on the Key.

## KEY

- 4 **Skilled** — Can perform job with no additional training
- 3 **Moderately Skilled** — Has performed job during training program; limited additional training may be required
- 2 **Limited Skill** — Has performed job during training program; additional training is required to develop skill
- 1 **Unskilled** — Is familiar with process, but is unable to perform job

## EVALUATOR'S COMMENTS

---

---

---



# **CABINETS, SHELVES, AND BUILT-INS**

**CARPENTRY SERIES**



# CABINETS, SHELVES, AND BUILT-INS CARPENTRY SERIES JOB SHEET

# 1

Student Name: \_\_\_\_\_ Score: \_\_\_\_\_

## INSTALL A FACTORY-BUILT CABINET.

### BASIC SKILLS



### INTRODUCTION

It is always practical to prepare for installing a factory built cabinet by first drawing a scale outline of the room. Graph paper is excellent for this project. Use a scale of  $\frac{1}{2}'' = 1'$ . Start by measuring the room carefully. Be sure to mark window and door opening including trim as well as any other obstructions or details. Draw in base cabinets first, with the top cabinet properly placed over appliances or insets.

Ordering a factory-built cabinet requires using the stock number listed with the illustration found in manufacturer's catalogue. Usually the beginning letters indicate the cabinet type and the first two numbers represent the width. Some manufacturers will also indicate the height of the cabinets in a second set of numbers. Be sure to remember to indicate whether or not the cabinet doors will be hinged on the right or left sides when ordering.

Some general guidelines to follow when installing factory built-in cabinets are:

- Align the tops of the wall cabinets 7' from the floor.
- Locate the wall studs and mark them on the wall before beginning.
- Mount the wall cabinet securely so that it will be able to bear normal loads.
- Shim or scribe cabinets when the walls and/or floor are not plumb.

- Start the installation of the wall cabinet from the corner and work toward windows and doorways.
- Use wood screws long enough to go through the back rail and wall covering and extend at least 1" in the stud.
- When two or more narrow wall cabinets are being placed side by side, place them on the floor and fasten them together.

The order in which the top or base cabinet is installed is not important. Always refer to manufacturer's specific instructions before beginning the installation.

## EQUIPMENT AND SUPPLIES

- |   |                                 |
|---|---------------------------------|
| ■ 2 x 4 scrap material                  | ■ Handsaw                       |
| ■ 2" and 2½" inch #8 or #10 wood screws | ■ Level                         |
| ■ Block plane                           | ■ Nail sets                     |
| ■ Cabinet units                         | ■ Sawhorses - one pair          |
| ■ Circular saw and extension cord       | ■ Personal protective equipment |
| ■ Claw hammer                           | ■ Scribe                        |
| ■ Framing square                        | ■ Shim shingles                 |

## PROCEDURE

**Yes**   **No**

- |                          |                          |  |
|--------------------------|--------------------------|--|
| <input type="checkbox"/> | <input type="checkbox"/> | 1. Put on personal protective equipment.   |
| <input type="checkbox"/> | <input type="checkbox"/> | 2. Remove the skids, bracing, or any other packaging from both units.              |
|                          |                          | <b>NOTE</b> ► You may want to take the cabinet doors off for ease of installation. |
|                          |                          | 3. Install wall unit.  |
| <input type="checkbox"/> | <input type="checkbox"/> | A. Check the wall unit to be sure it is the same length as the base unit.          |
| <input type="checkbox"/> | <input type="checkbox"/> | B. Check to make sure the wall unit is the correct length for the wall.            |

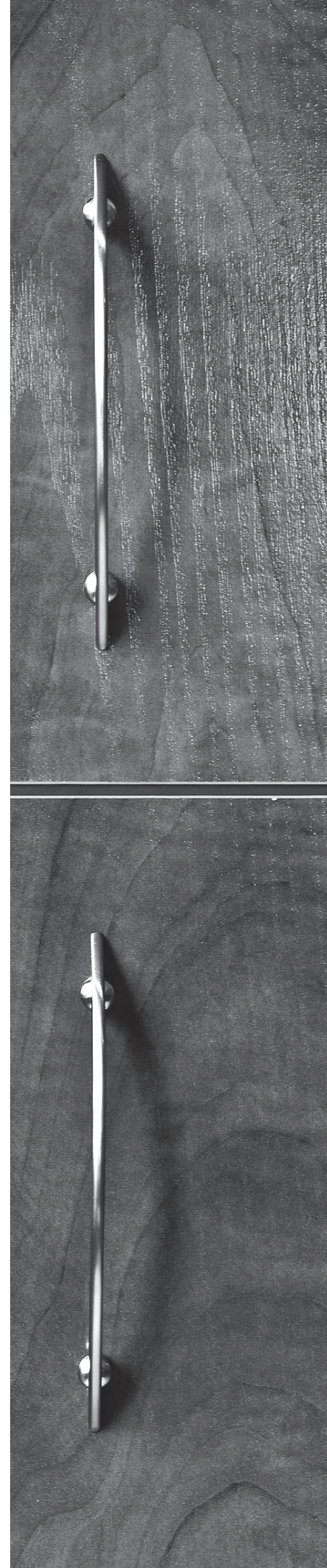

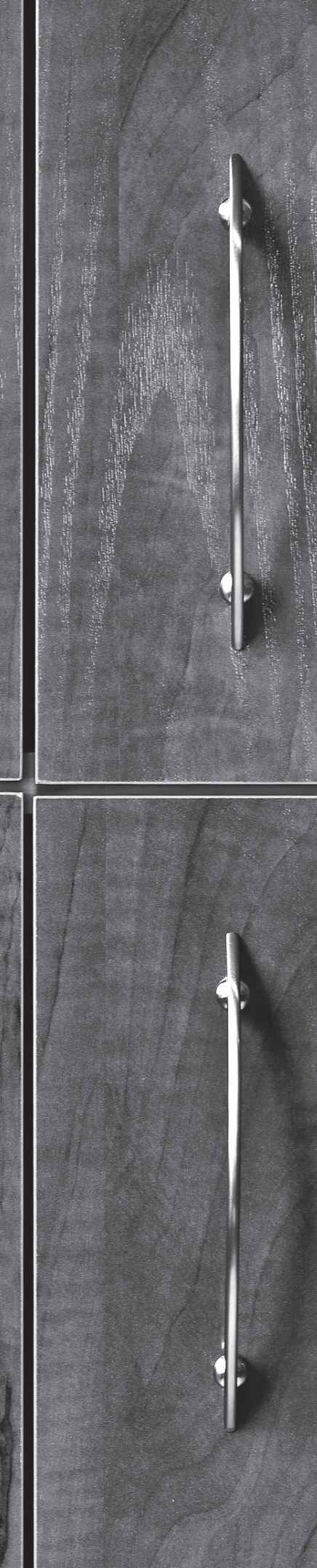

Yes No

C. Find and mark stud locations on wall.

D. Mark stud locations on the back of the wall unit.

E. Drill holes through the mounting strips (top and bottom) and into the studs.

F. Countersink the holes in the face of the mounting strips.

G. Cut and build two 2 x 4 T's slightly longer than the desired distance between the wall cabinet and the floor.

H. Set the wall cabinet on top of the T's and wedge the cabinet up tight to the soffit.

FIGURE 139

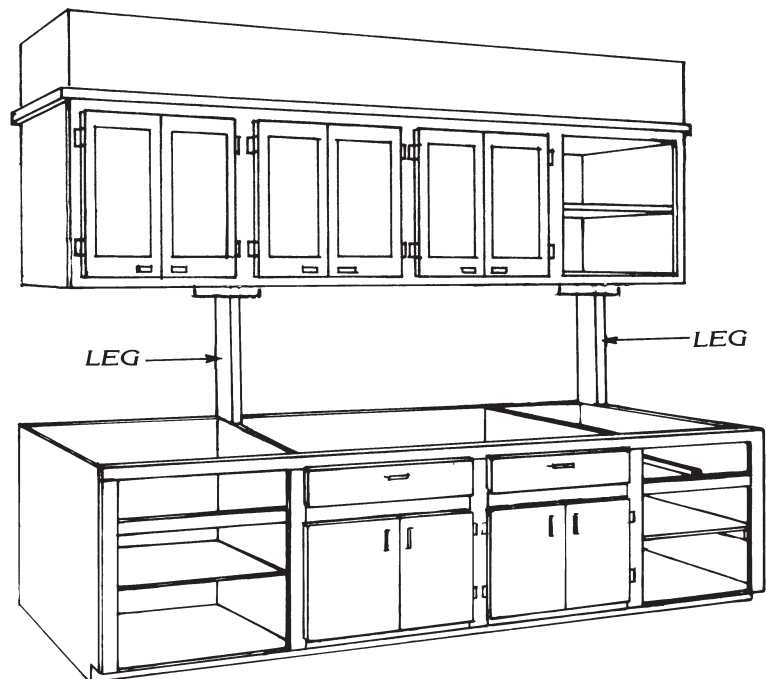

I. Check the cabinet for plumb and level.

**NOTE** ► If the top cabinet is not plumb and level, it will be necessary to scribe and cut it.

J. Use wood screws to secure the wall cabinet to the wall.

K. Remove the T's from under the wall cabinet.

Yes No

- L. Recheck the wall unit to be sure it is plumb and level and make any necessary adjustments.

4. Install the base cabinet.

- A. Set the base cabinet near its approximate location.
- B. Make sure there is no wall baseboard or other trim that may interfere with the setting of the cabinet.
- C. Move the cabinet against the wall in its proper location.
- D. Shim the base unit until the top of the cabinet is level across the width and depth.

FIGURE 140

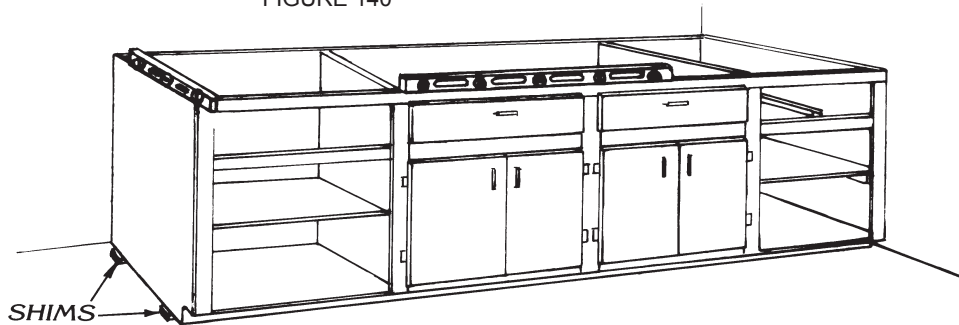

- E. Adjust the scribe to the distance between the height of the cabinet and the required height.
- F. Scribe both ends at the bottom and across the front on the kickboard.
- G. Pull the cabinet from the wall and cut both ends and front to the established lines.
- H. Check the back of the cabinet and trim if it extends below the end cut.
- I. Recheck the unit to be sure it is level and plumb and make necessary adjustments.
- J. Drill holes through the mounting strips into the wall studs.

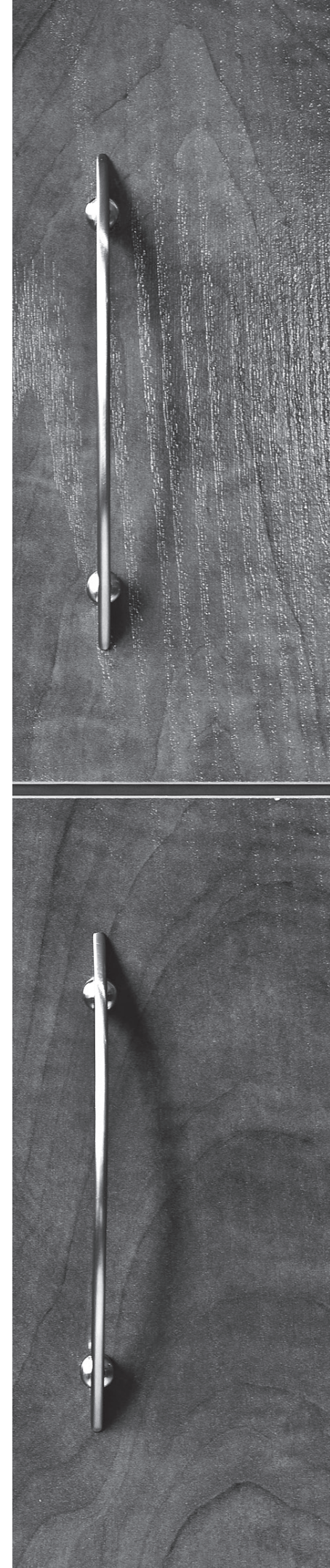

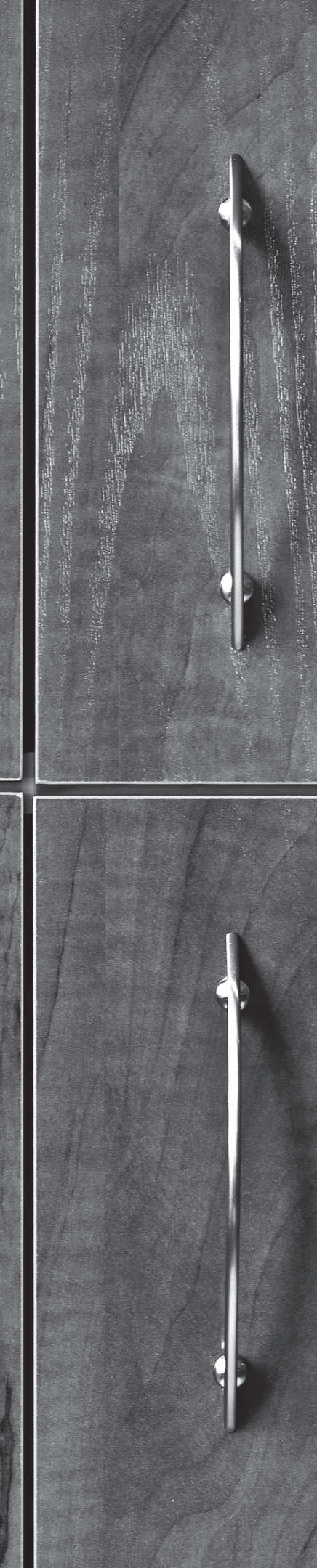

Yes No



K. Use the wood screws to secure the cabinet unit to the wall.



L. Reinstall doors and drawers if necessary and replace any hardware or molding that is required.



M. Recheck the unit to be sure it is level and plumb.

5. Install the counter top.



A. Check the length of the counter top to be sure it corresponds with the length of the base cabinet.



B. Set the counter top on top of the base cabinet.

**NOTE ►** Be sure the counter top is tight against the walls.

FIGURE 141

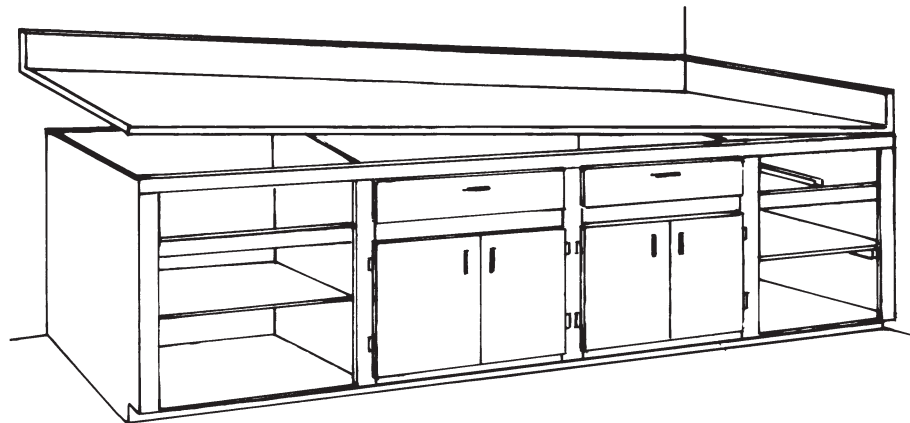

C. If the backsplash does NOT fit tight against the wall trim it to fit snugly.

1) Scribe the top of the backsplash.

2) Remove the counter top from the base cabinet and set it on a pair of sawhorses.

3) Trim the backsplash to the scribed line using a block plane or a belt sander.

4) Replace the counter top to the top of the base cabinet, checking along the wall for proper fit.



5) Fasten securely with screws.

**CAUTION:** Make sure of appropriate screw length being careful not to drill through the counter top.

6) Secure the counter top to the base cabinet with the proper size of wood screws.

**NOTE** ► Cabinets are set and ready for trim.

6. Have your instructor check your work.

7. Clean up the area and put away the equipment and supplies.

## PRODUCT EVALUATION

### SKILL TEST RECORD

**Evaluator note:** Rate the student on the following criteria by circling the appropriate numbers. Each criterion must receive a rating of "3" or higher to demonstrate student mastery. (See Key below.) A student who is unable to demonstrate mastery should review the material and submit another product for evaluation.

Criteria:

Cabinets plumb ( $\frac{1}{8}$ "	4	3	2	1
Cabinets level ( $\frac{1}{8}$ "	4	3	2	1
Cabinets properly secured to wall	4	3	2	1
Fasteners in proper place plumb ( $\frac{1}{8}$ "	4	3	2	1
Fitted countertop to wall ( $\frac{1}{8}$ "	4	3	2	1

### AVERAGE RATING

**Evaluator note:** To obtain an average rating for the Profile of Training Mastery, total the points in Product Evaluation and divide by the total number of criteria. Circle the rating on the Key.

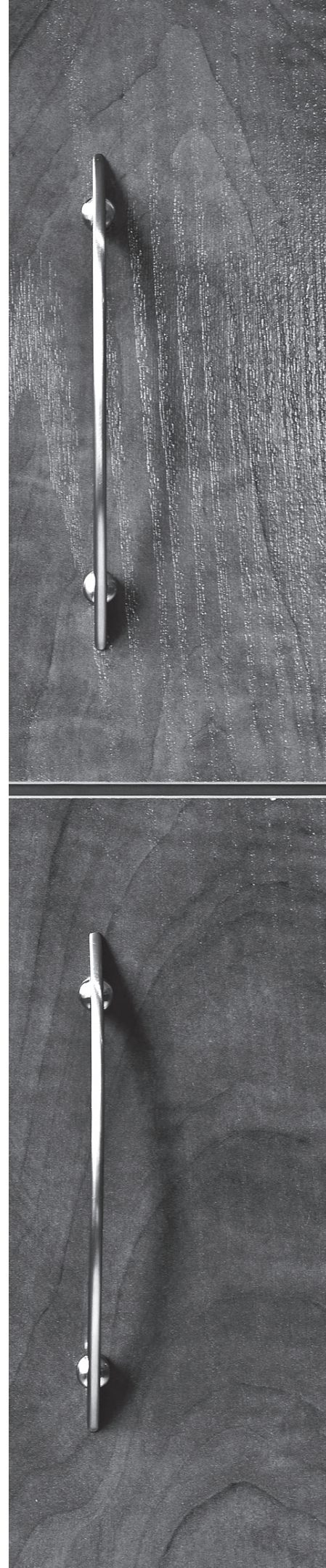

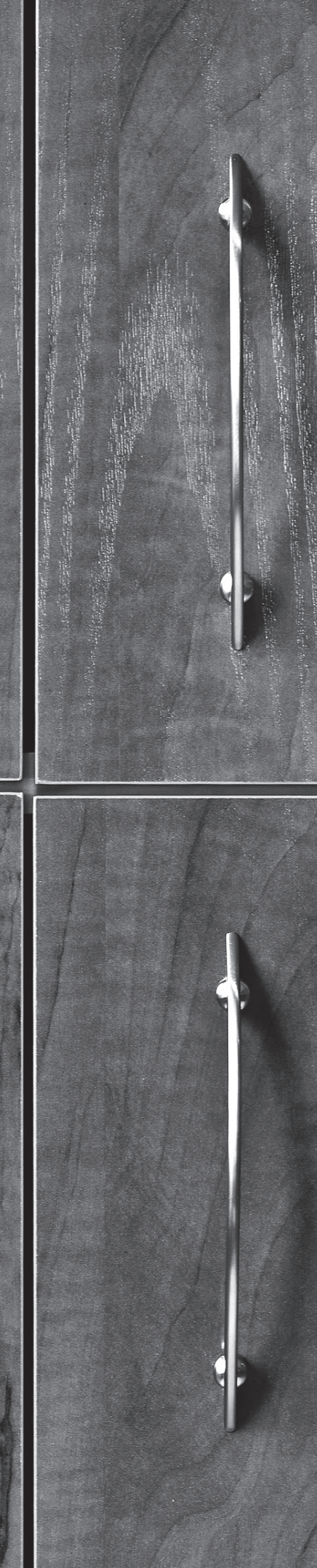

## KEY

- 4 **Skilled** — Can perform job with no additional training
- 3 **Moderately Skilled** — Has performed job during training program; limited additional training may be required
- 2 **Limited Skill** — Has performed job during training program; additional training is required to develop skill
- 1 **Unskilled** — Is familiar with process, but is unable to perform job

## EVALUATOR'S COMMENTS

---

---

---



Student Name: \_\_\_\_\_ Score: \_\_\_\_\_

## INSTALL SHELVES IN A CLOSET.

### BASIC SKILLS



READING



MATHEMATICS



CRITICAL  
THINKING



EMPLOYABILITY

### INTRODUCTION

Shelves may be built-in behind a closet door or it may consist of an open cabinet with flush or panel doors. Adjustable shelves are sometimes used and are supported by cleats. The cleats are nailed to the wall and may be moved to adjust the shelf height.

### EQUIPMENT AND SUPPLIES

- 1 x 2 shelf supports, or battens
- 1 x 4 (if closet rod is below the shelf)
- 10d finish nails
- Circular saw and extension cord
- Claw hammer
- Framing square
- Handsaw
- Level
- Nail sets
- Personal protective equipment
- Scribe
- Shelving
- Steel tape

## PROCEDURE

Yes No

- |                          |                          |  |
|--------------------------|--------------------------|--|
| <input type="checkbox"/> | <input type="checkbox"/> | 1. Put on personal protective equipment.   |
| <input type="checkbox"/> | <input type="checkbox"/> | 2. Install shelf supports.   |
| <input type="checkbox"/> | <input type="checkbox"/> | A. Mark the height in the back corners of the closet where you want the underside of your shelf.                           |
| <input type="checkbox"/> | <input type="checkbox"/> | B. Mark the opposite corner by leveling across.  |
| <input type="checkbox"/> | <input type="checkbox"/> | C. Mark the end walls out from the corners of the width of the shelf using a level.  |
| <input type="checkbox"/> | <input type="checkbox"/> | D. Cut the side supports and fasten them to the studs.   |
|                          |                          | <b>NOTE ►</b> Adhesive may be used for additional strength. Depending on stud locations special fasteners may be required. |
| <input type="checkbox"/> | <input type="checkbox"/> | E. Check to make sure the supports are level.  |
| <input type="checkbox"/> | <input type="checkbox"/> | F. Cut the back support to the length.   |
| <input type="checkbox"/> | <input type="checkbox"/> | G. Fasten the back support to the wall with the top even with the mark on the wall, using one nail at each stud.           |
|                          |                          | 3. Install the shelf.  |
| <input type="checkbox"/> | <input type="checkbox"/> | A. Use the framing square to check the corners for square.   |

FIGURE 142

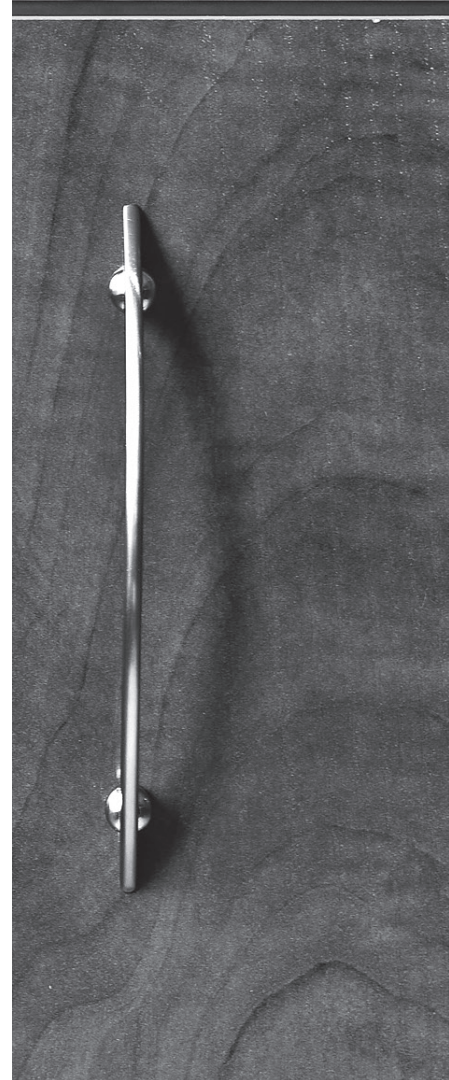
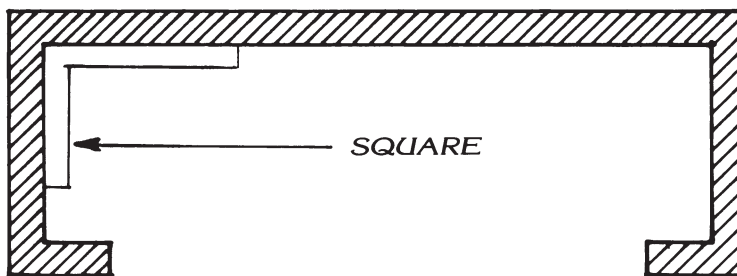

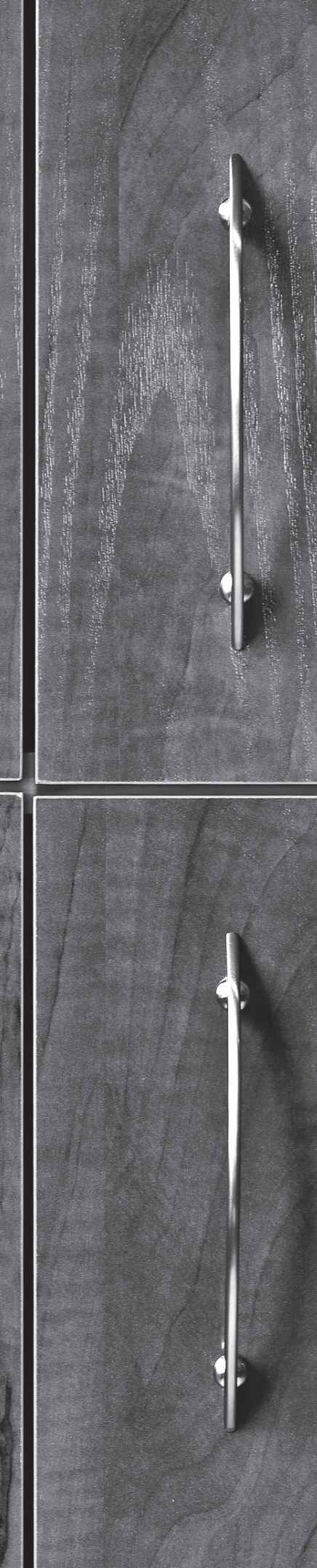

Yes No

B. Check the measurements across the rear wall and at the face of the shelf.

FIGURE 143

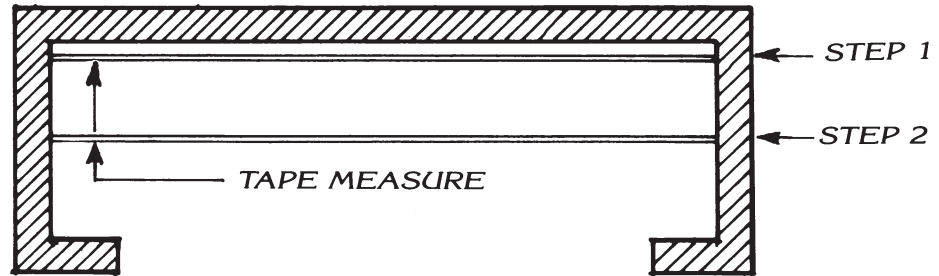

C. Cut the shelf slightly longer than the longest measurement.

D. Place one end of the shelf on one of the supports and lower the other end of the shelf as far as possible.

FIGURE 144

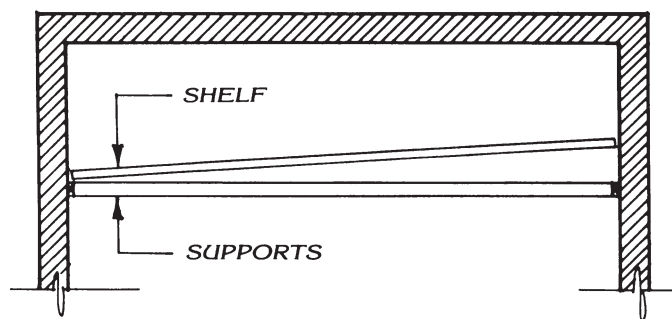

E. Scribe the shelf along the left side; then remove and cut the shelf on this line.

F. Recheck the measurement across the closet at the front edge of the shelf, and transfer this measurement to the top of the shelf.

G. Replace the shelf on the supports, this time with the shelf resting on the opposite support.

H. Set the scribe to match the mark on the shelf, then scribe the top of the shelf.

- I. Remove and cut the shelf along the scribed mark.
- J. Replace the shelf and if necessary, fasten to supports.
- K. Install a face piece for strength and appearance.
- L. Repeat the procedure for each shelf.
- 4. Have your instructor check your work.
- 5. Clean up the area and put away the equipment and supplies.

## PRODUCT EVALUATION

### SKILL TEST RECORD

**Evaluator note:** Rate the student on the following criteria by circling the appropriate numbers. Each criterion must receive a rating of “3” or higher to demonstrate student mastery. (See Key below.) A student who is unable to demonstrate mastery should review the material and submit another product for evaluation.

Criteria:

Shelf proper height ( $\frac{1}{8}$ "	4	3	2	1
Shelf level ( $\frac{1}{8}$ "	4	3	2	1
Shelf fits support ( $\frac{1}{4}$ "	4	3	2	1

### AVERAGE RATING

**Evaluator note:** To obtain an average rating for the Profile of Training Mastery, total the points in Product Evaluation and divide by the total number of criteria. Circle the rating on the Key.

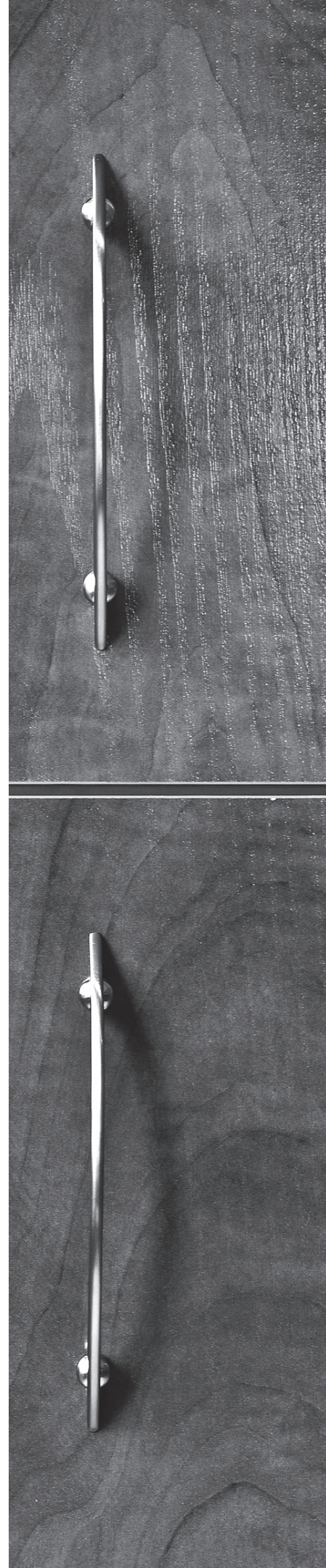



## KEY

- 4 **Skilled** — Can perform job with no additional training
- 3 **Moderately Skilled** — Has performed job during training program; limited additional training may be required
- 2 **Limited Skill** — Has performed job during training program; additional training is required to develop skill
- 1 **Unskilled** — Is familiar with process, but is unable to perform job

## EVALUATOR'S COMMENTS

---

---

---





# **FLOOR FINISHING**

**CARPENTRY SERIES**



Student Name: \_\_\_\_\_ Score: \_\_\_\_\_

## INSTALL UNDERLAYMENT.

### BASIC SKILLS



### INTRODUCTION

At least 24 hours prior to installation, lean the panels in the room where they will be used. This will condition the panels to the rooms atmosphere and minimize expansion and contraction of the panels.

### EQUIPMENT AND SUPPLIES

- 1/4" x 4' x 8' hardboard panels for underlayment
- 15-pound felt
- Chalk line
- Circular saw and extension cord
- Claw hammer
- Framing square
- Personal protective equipment
- Pointing or margin trowel
- Power fastener, fasteners, and manufacturer's instructions
- Power sander and sanding belts
- Ring-shank, grooved, or cement-coated nails Hard putty or wood filler and manufacturer's instructions
- Saw horses — one pair
- Straightedge
- Steel tape
- Utility knife

## PROCEDURE

Yes No

- |                          |                          |  |
|--------------------------|--------------------------|--|
| <input type="checkbox"/> | <input type="checkbox"/> | 1. Put on personal protective equipment.   |
| <input type="checkbox"/> | <input type="checkbox"/> | 2. Prepare a clean work surface.   |
| <input type="checkbox"/> | <input type="checkbox"/> | 3. Mark centers of all floor joists on walls.  |
| <input type="checkbox"/> | <input type="checkbox"/> | 4. Apply 15-pound felt, lapping head and side joints at least 4" and using only enough fasteners to hold felt in place.  |
| <input type="checkbox"/> | <input type="checkbox"/> | 5. Snap lines along centers of floor joists.   |
|                          |                          | 6. Install first underlayment panel.   |
| <input type="checkbox"/> | <input type="checkbox"/> | A. Position panel in a corner at right angle to floor joists with $\frac{1}{8}$ " allowance between edges of panel and wall.   |
| <input type="checkbox"/> | <input type="checkbox"/> | B. Secure panel, placing approved fasteners $\frac{3}{8}$ " in from edges and approximately 6" on center over entire surface of panel. This may vary based on local humidity conditions. |
|                          |                          | 7. Install remaining panels.   |
|                          |                          | <b>NOTE</b> ► Be sure to stagger the head joints of the panels and avoid aligning the joints in the underlayment with the joints in the subfloor.  |
| <input type="checkbox"/> | <input type="checkbox"/> | A. Measure, cut, and fit panels to size, allowing approximately $\frac{1}{16}$ " between panels on all sides.  |
| <input type="checkbox"/> | <input type="checkbox"/> | B. Secure panels, placing fasteners $\frac{3}{8}$ " in from edges and approximately 6" on center over surface of each panel.   |
| <input type="checkbox"/> | <input type="checkbox"/> | 8. Fill all joints and cracks with putty or wood filler and let dry for recommended time.  |
| <input type="checkbox"/> | <input type="checkbox"/> | 9. Sand floor smooth.  |
| <input type="checkbox"/> | <input type="checkbox"/> | 10. Clean up area and put away equipment and supplies.   |

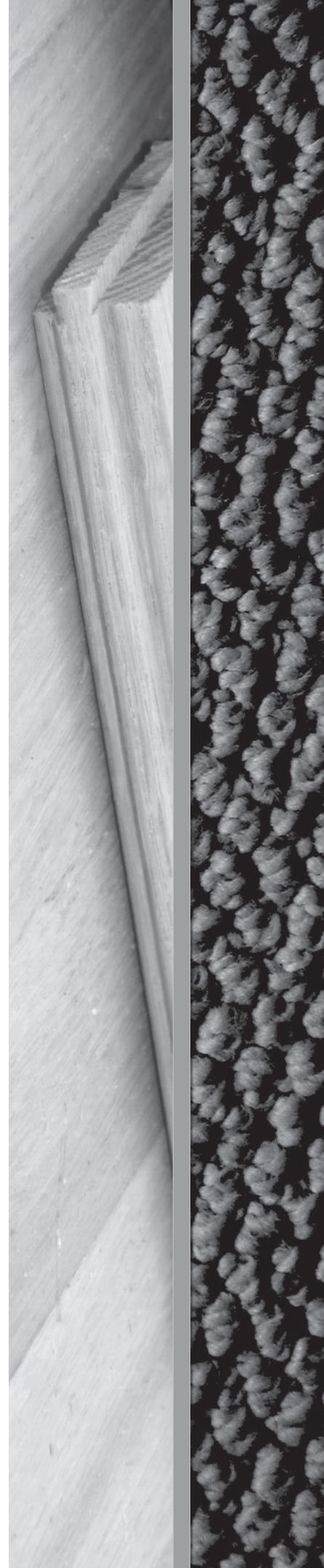

## PRODUCT EVALUATION

### SKILL TEST RECORD

**Evaluator note:** Rate the student on the following criteria by circling the appropriate numbers. Each criterion must receive a rating of "3" or higher to demonstrate student mastery. (See Key below.) A student who is unable to demonstrate mastery should review the material and submit another product for evaluation.

Criteria:

Felt lapped properly ( $\frac{1}{2}$ "	4	3	2	1
Underlayment panel at right angle to floor joists	4	3	2	1
Fastener spacing correct (1")	4	3	2	1
Joints filled and smooth	4	3	2	1
All joints finished smoothly	4	3	2	1

### AVERAGE RATING

**Evaluator note:** To obtain an average rating for the Profile of Training Mastery, total the points in Product Evaluation and divide by the total number of criteria. Circle the rating on the Key.

### KEY

- 4 Skilled** — Can perform job with no additional training
- 3 Moderately Skilled** — Has performed job during training program; limited additional training may be required
- 2 Limited Skill** — Has performed job during training program; additional training is required to develop skill
- 1 Unskilled** — Is familiar with process, but is unable to perform job

## EVALUATOR'S COMMENTS

---

---

---

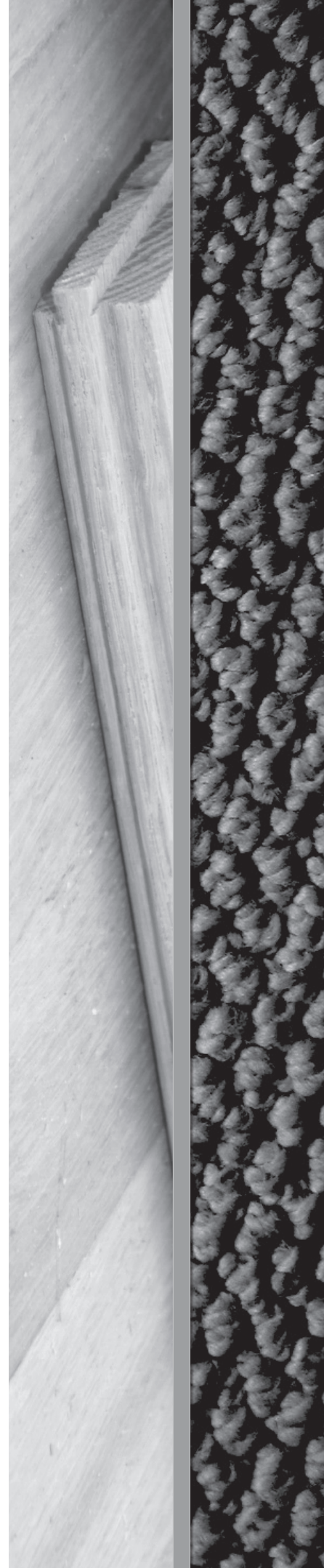

Student Name: \_\_\_\_\_ Score: \_\_\_\_\_

## INSTALL RESILIENT TILE.

### BASIC SKILLS



### INTRODUCTION

Resilient tile can be used in many different situations because it can be laid onto many different surfaces and requires little preparation. Resilient tile is fairly easy to install and it comes in a wide selection of colors and patterns. Since there are many different types and styles of resilient tile, be sure to read the manufacturer's instructions carefully before beginning an installation. Follow the manufacturer's instructions if different from the procedure given in this job sheet.

### EQUIPMENT AND SUPPLIES

- Adhesive and manufacturer's instructions
- Chalk line
- Linoleum knife
- Notched trowel
- Personal protective equipment
- Propane torch
- Resilient tile
- Respiratory equipment as required by the MSDS
- Steel tape
- Tile cutter



## PROCEDURE

Yes No

- |                          |                          |  |
|--------------------------|--------------------------|--|
| <input type="checkbox"/> | <input type="checkbox"/> | 1. Put on personal protective equipment and clean work surface.                |
| <input type="checkbox"/> | <input type="checkbox"/> | 2. Lay out and snap chalk lines for starting point.                            |
| <input type="checkbox"/> | <input type="checkbox"/> | A. Locate center of end walls and mark.  |
|                          |                          | <b>NOTE</b> ► Disregard any breaks or irregularities in the shape of the room. |
| <input type="checkbox"/> | <input type="checkbox"/> | B. Snap a chalk line between end-wall center-line marks.                       |
| <input type="checkbox"/> | <input type="checkbox"/> | C. Locate center line of sidewalls.  |
| <input type="checkbox"/> | <input type="checkbox"/> | D. Snap a chalk line between sidewall center-line marks.                       |
| <input type="checkbox"/> | <input type="checkbox"/> | E. Use 3-4-5 method to see that lines are square. See Figure 145.              |

FIGURE 145

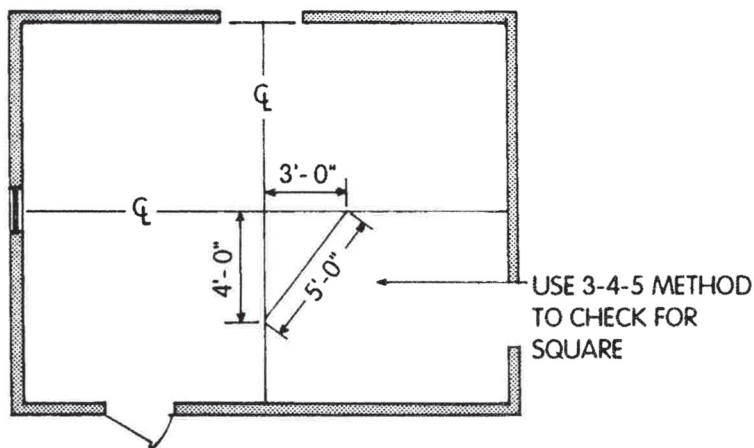

- |                          |                          |  |
|--------------------------|--------------------------|--|
| <input type="checkbox"/> | <input type="checkbox"/> | 3. Apply even coat of adhesive over $\frac{1}{4}$ of floor area; spread adhesive even with chalk lines, but do not cover them. See Figure 146. |
|                          |                          | <b>NOTE</b> ► Follow adhesive manufacturer's recommendations and instructions.   |

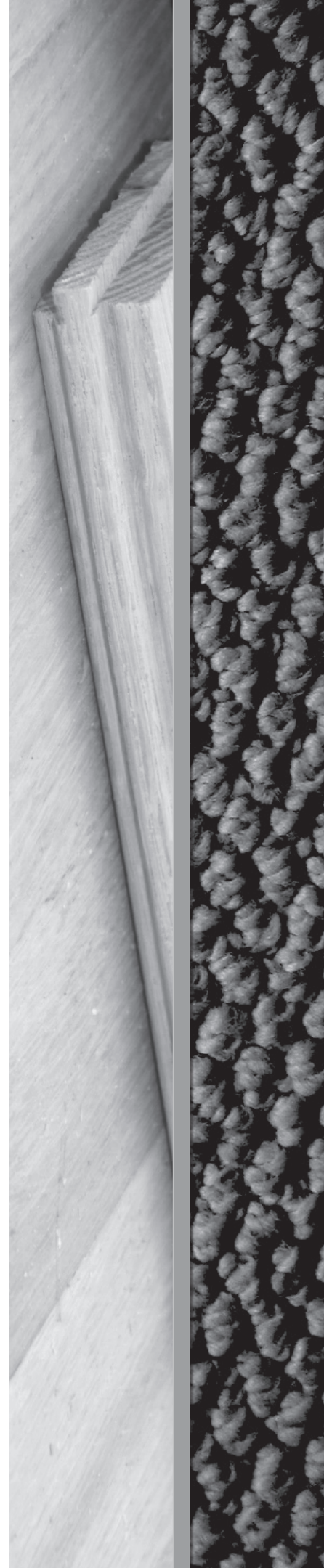
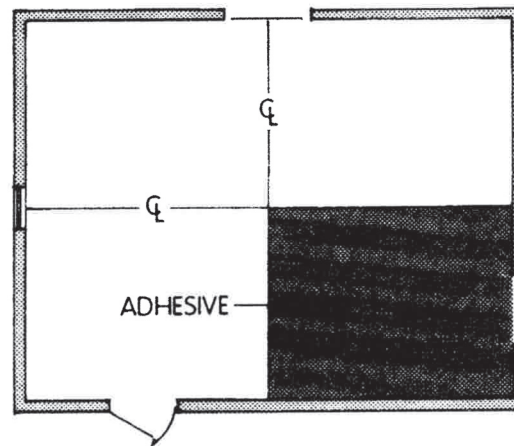

FIGURE 146



Yes No

4. Allow adhesive to cure in accordance with manufacturer's instructions.

5. Lay tile in first ¼ of floor area.

A. Mix tiles from different boxes together.

**NOTE** ▶ Mixing tiles prevents differences in colors of production lots from being obvious on completed floor.

B. Place first tile in corner formed by chalk lines, aligning two sides even with chalk lines.

**NOTE** ▶ Be careful when laying tile not to slide it into position; this may cause the adhesive to ooze up between the joints.

C. Position second tile tight against the first tile and even with chalk line. Make sure pattern of tile runs correctly.

**NOTE** ▶ Many patterns of resilient tile are laid so that grains and colorations are at right angles to each other, and some tiles have continuous patterns. Position tiles to allow for the continuation of the pattern.

D. Work from chalk lines toward wall, laying full tiles until all but border area is covered. See Figure 147.

FIGURE 147

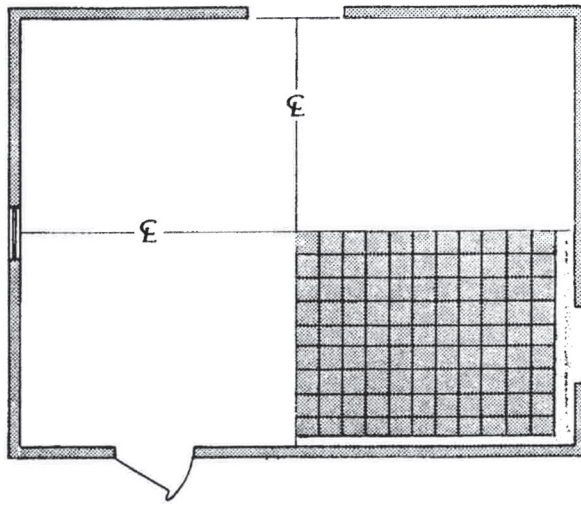

Yes No

6. Apply an even coat of adhesive over second  $\frac{1}{4}$  of floor area. See Figure 148.

FIGURE 148

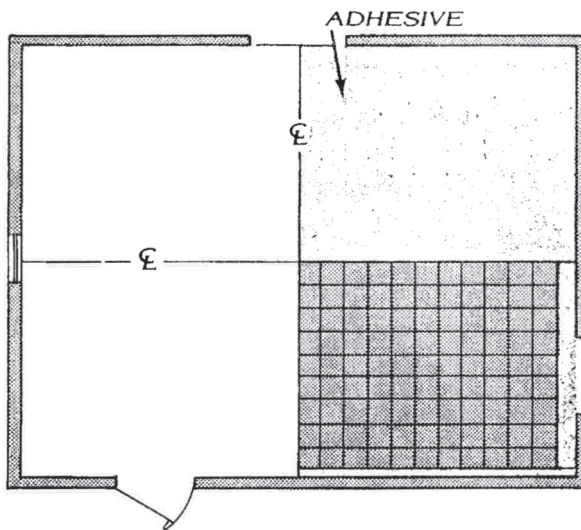

7. Allow adhesive to cure in accordance with manufacturer's instructions.

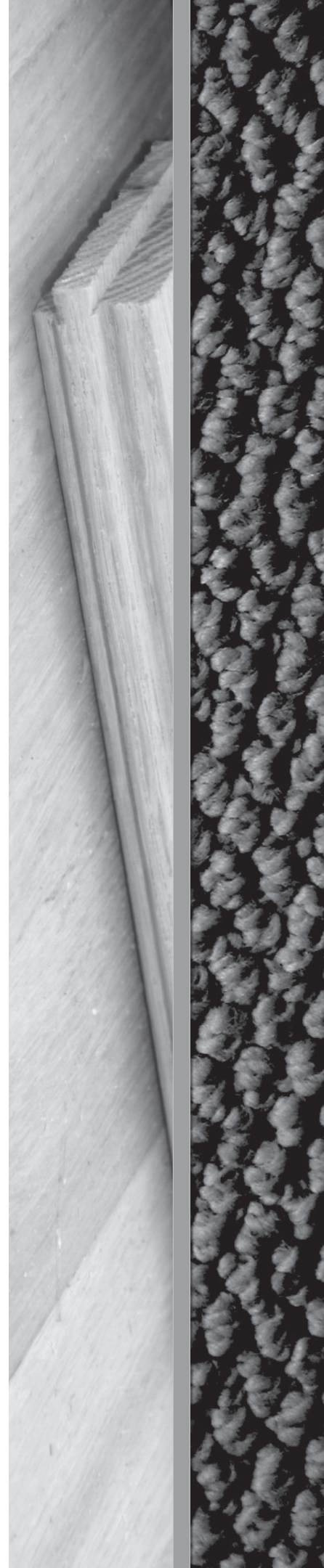

Yes No

- 8. Lay tile, following procedures in steps 5-A through 5-D.
- 9. Spread adhesive and lay tile in third and fourth quarters of floor area until all but border area is covered. See Figure 149.

FIGURE 149

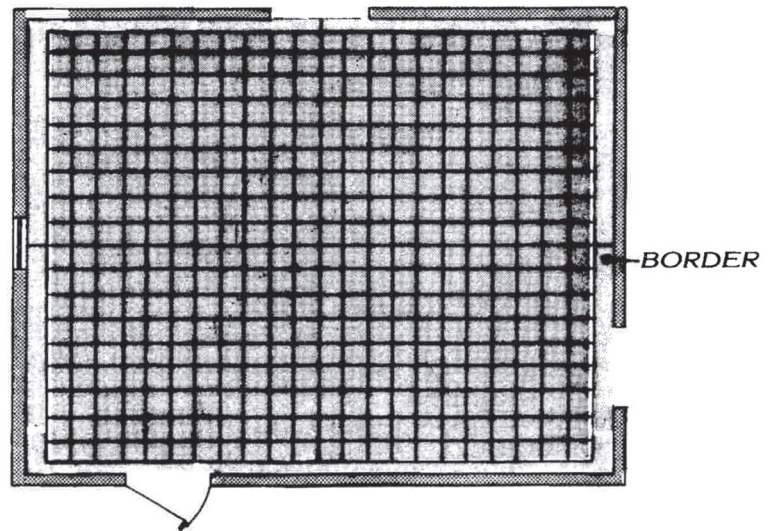

- 10. Check installation for proper positioning and fit.
- 11. Mark and cut first border tile to proper width.
  - A. Place a loose tile squarely over one corner tile.
  - B. Place another tile against wall and overlapping loose tile. See Figure 150.

FIGURE 150

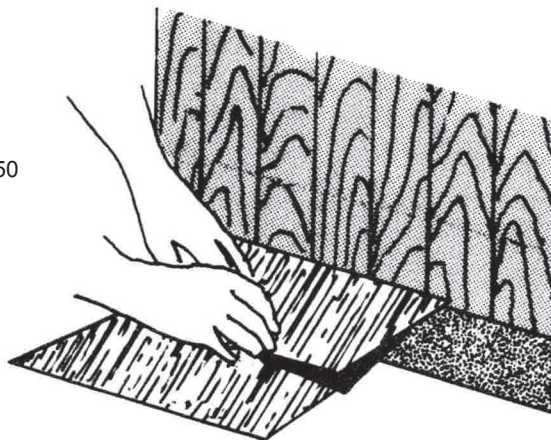

Yes No

- |                          |                          |   |
|--------------------------|--------------------------|---|
| <input type="checkbox"/> | <input type="checkbox"/> | C. Mark face of bottom loose tile where the tile above overlaps it.                                   |
| <input type="checkbox"/> | <input type="checkbox"/> | D. Move top loose tile so that it is against the other corner wall and overlapping bottom loose tile. |
| <input type="checkbox"/> | <input type="checkbox"/> | E. Mark face of bottom loose tile where the tile above overlaps it.                                   |
| <input type="checkbox"/> | <input type="checkbox"/> | F. Cut tile on marked lines. See Figure 151.  |

FIGURE 151

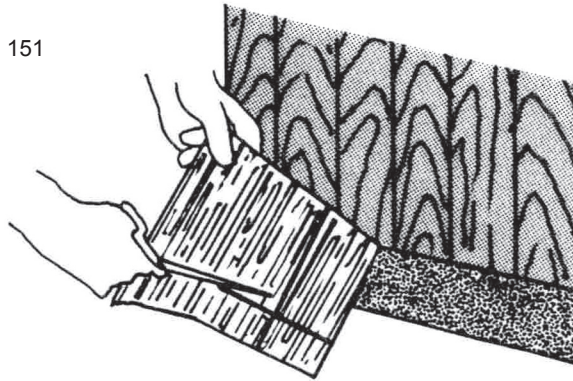

- |                          |                          |   |
|--------------------------|--------------------------|---|
| <input type="checkbox"/> | <input type="checkbox"/> | G. Lay tile.  |
| <input type="checkbox"/> | <input type="checkbox"/> | 12. Use overlapping tiles to continue marking, cutting, and installing border tiles until border is completed.  |
|                          |                          | <b>NOTE</b> ► Where border tiles fit against door casings and other intricate objects, you may have to heat the tiles in order to cut and make them fit properly. |
| <input type="checkbox"/> | <input type="checkbox"/> | 13. Clean up area and put away equipment and supplies.  |

## PRODUCT EVALUATION

### SKILL TEST RECORD

**Evaluator note:** Rate the student on the following criteria by circling the appropriate numbers. Each criterion must receive a rating of "3" or higher to demonstrate student mastery. (See Key below.) A student who is unable to demonstrate mastery should review the material and submit another product for evaluation.

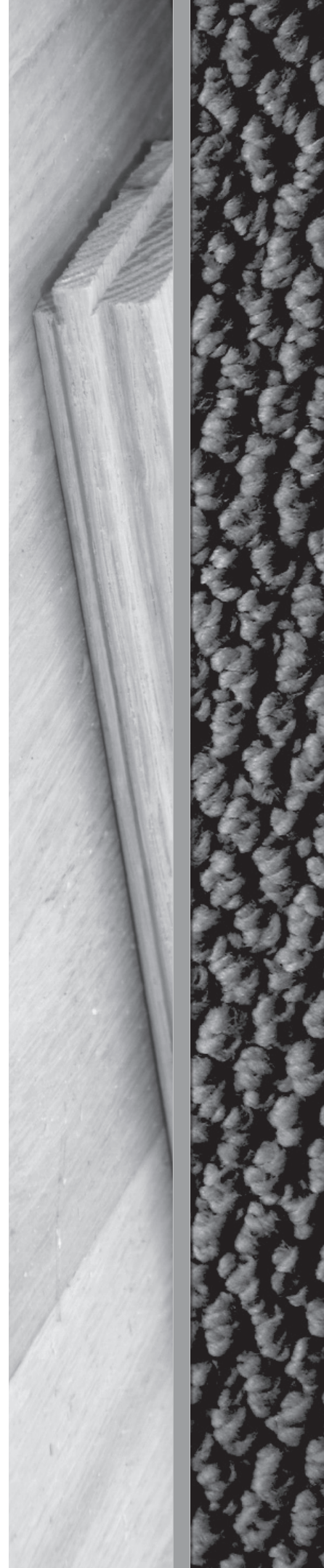

Criteria:

Row straight ( $\frac{1}{16}$ " overall)	4	3	2	1
Smooth cuts on tile	4	3	2	1
Tiles fit tight	4	3	2	1
Tiles parallel to walls	4	3	2	1

## AVERAGE RATING

**Evaluator note:** To obtain an average rating for the Profile of Training Mastery, total the points in Product Evaluation and divide by the total number of criteria. Circle the rating on the Key.

## KEY

- 4 Skilled** — Can perform job with no additional training
- 3 Moderately Skilled** — Has performed job during training program; limited additional training may be required
- 2 Limited Skill** — Has performed job during training program; additional training is required to develop skill
- 1 Unskilled** — Is familiar with process, but is unable to perform job

## EVALUATOR'S COMMENTS

---

---

---



Student Name: \_\_\_\_\_ Score: \_\_\_\_\_

### **INSTALL TONGUE-AND-GROOVE HARDWOOD STRIP FLOORING.**

#### **BASIC SKILLS**



#### **INTRODUCTION**

At least twenty-four hours prior to installation, loosely stack flooring in room where it will be used. This will condition the flooring to the room's atmosphere and minimize the expansion and contraction of the flooring.

#### **EQUIPMENT AND SUPPLIES**

- Chalk line
- Circular saw and extension cord
- Claw hammer
- Flooring nails
- Nail set
- Personal protective equipment
- Proper respiratory protective equipment as required by Material Safety Data Sheet (MSDS).
- Power floor nailer, nails, and manufacturer's instructions
- Saw horses — one pair
- Steel tape
- Table saw or radial-arm saw
- 15-pound felt
- Tongue-and-groove hardwood strip flooring.
- Utility knife



## PROCEDURE

Yes No

- |                          |                          |   |
|--------------------------|--------------------------|---|
| <input type="checkbox"/> | <input type="checkbox"/> | 1. Put on personal protective equipment and clean work surface.   |
| <input type="checkbox"/> | <input type="checkbox"/> | 2. Mark centers of all floor joists on walls.   |
| <input type="checkbox"/> | <input type="checkbox"/> | 3. Apply 15-pound felt, lapping head and side joints at least 4" and using only enough fasteners to hold felt in place. See Figure 152.   |
| <input type="checkbox"/> | <input type="checkbox"/> | 4. Snap lines along centers of floor joists.  |
| <input type="checkbox"/> | <input type="checkbox"/> | 5. Positioning a flooring strip at right angle to floor joists, measure over from wall the width of the flooring strip plus approximately 1/2" clearance; remove strip and snap a line at this point. |
| <input type="checkbox"/> | <input type="checkbox"/> | 6. Install first flooring strip.  |
| <input type="checkbox"/> | <input type="checkbox"/> | A. Reposition strip at right angle to floor joists with grooved edge toward wall, other edge along chalk line, and approximately 1/2" clearance between end of strip and wall.                        |

FIGURE 152

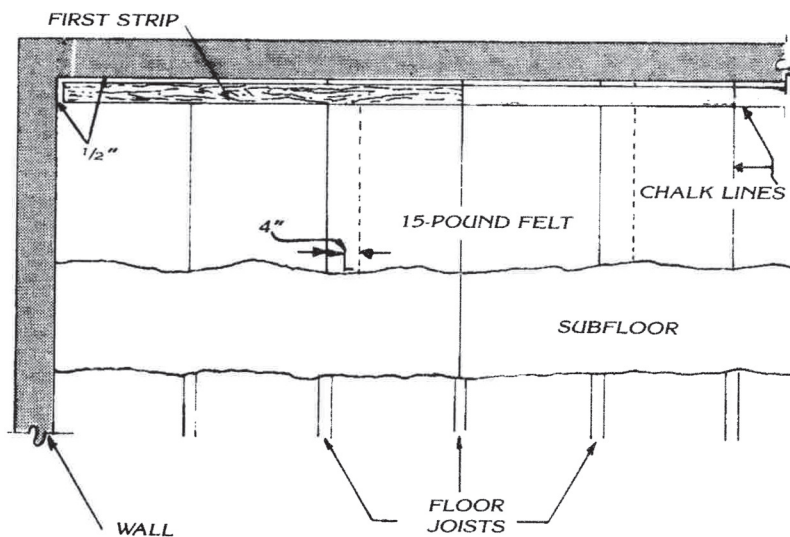

Yes No

B. Determine nailing requirements by using Table 1, and then face-nail first strip. See Figure 153.

TABLE 1: Length of Nail and Nail Spacing for Flooring

Flooring	Nail Length	Nail Spacing
$\frac{3}{8}$ "	$1\frac{1}{4}$ "	8"
$\frac{1}{2}$ "	$1\frac{1}{2}$ "	10"
$\frac{3}{4}$ "	$2\frac{1}{4}$ "	12" to 16"
1"	3"	16"

FIGURE 153

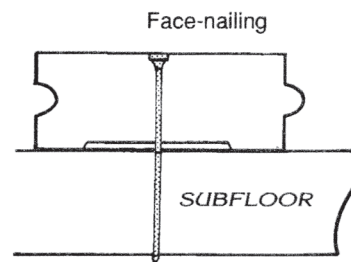

7. Install remaining strips in first row.

A. Lay each full strip with grooved edge toward wall and other edge along chalk line.

B. Face-nail, being sure each strip is snug against the one behind it and that end joints are tight and square.

C. Measure space required for last piece of flooring, allowing approximately  $\frac{1}{2}$ " clearance between end of piece and wall.

D. Cut last piece to measured length and face-nail in position.

8. Install first strip in second row.

A. Lay out first strip with first joint staggered at least 8" from first joint in adjacent row. See Figure 154.

FIGURE 154

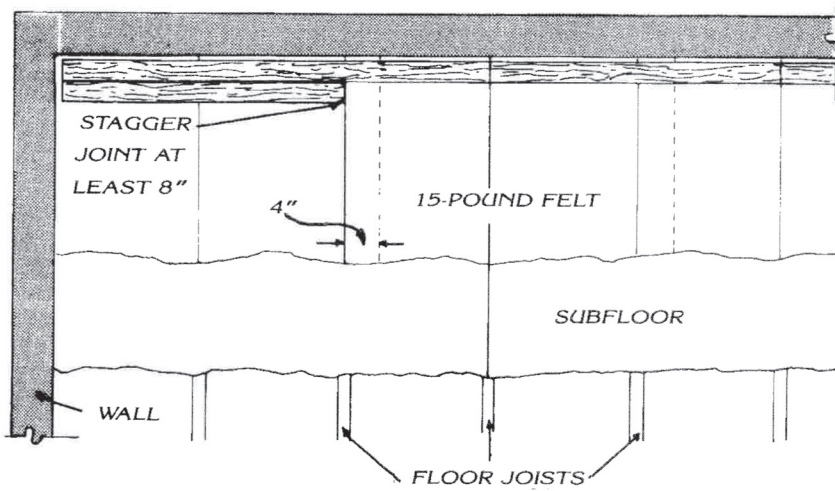

Yes No

- B. Blind-nail first strip in place by slanting nails at a 50° angle. See Figure 155.

FIGURE 155

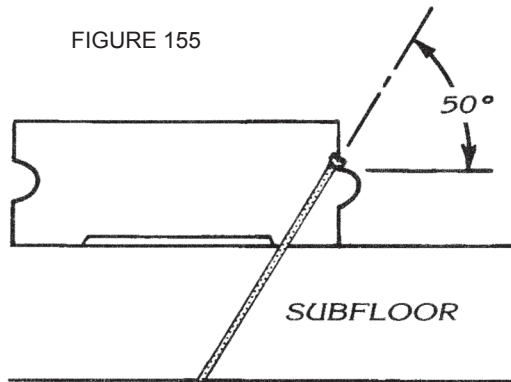

9. Install remaining strips in second row.

- A. Lay out 3' or 4' of flooring, staggering joints at least 8" from joints in adjacent row.

- B. Blind-nail 3' or 4' feet of flooring, being sure each strip is snug against the one behind it and that end joints are tight and square.

- C. Check to see that strips are running parallel; adjust as necessary.

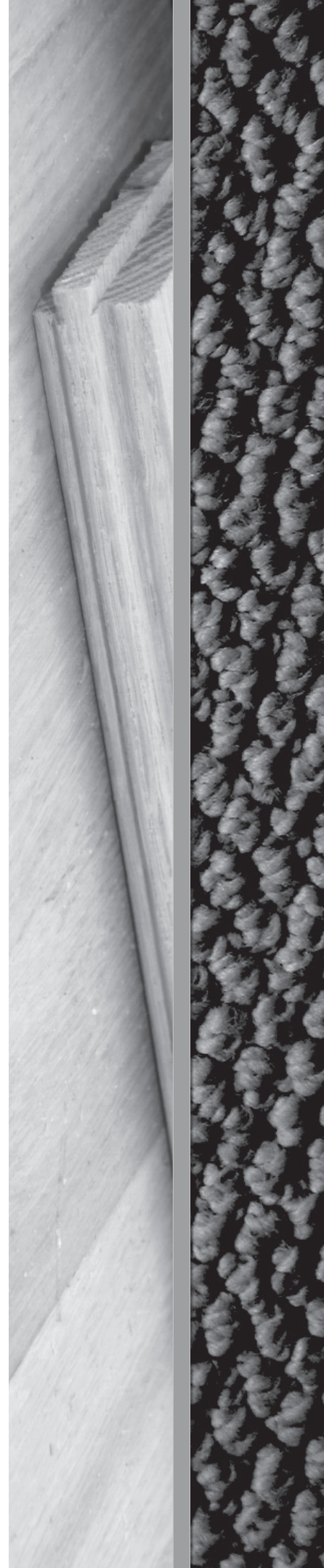

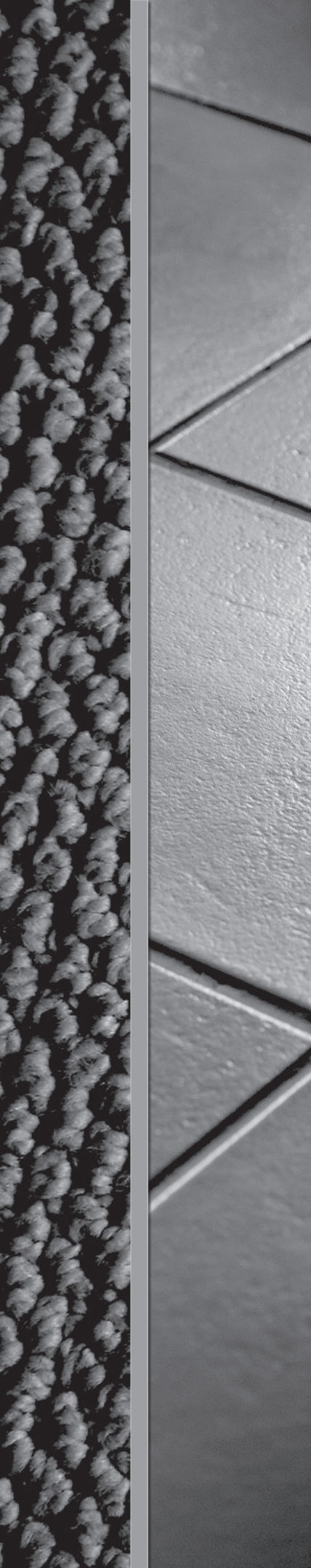
- 
- D. Continue installing strips, following procedures in step A.
  - E. Measure space required for last piece of flooring, allowing approximately ½" clearance between end of piece and wall.
  - F. Cut last piece to measured length and blind-nail in position.
  - 10. Continue laying out, blind-nailing, and checking strips until all but last row of flooring has been installed.
  - 11. Stop and recheck alignment.
  - 12. Install last row of flooring.
    - A. Measure to determine required width of strips in last row, allowing approximately ½" clearance between wall and flooring.
    - B. Rip strips to measured width if necessary.
    - C. Lay full strips, being sure each strip is snug against the one behind it and that end joints are tight and square; face-nail strips into position.
    - D. Measure space required for last piece of flooring, allowing approximately ½" clearance between end of piece and wall.
    - E. Cut last piece to measured length and face-nail into position.
  - 13. Check installation for accuracy and proper appearance.
  - 14. Set face nails and fill nail holes.
  - 15. Clean area and put away equipment and supplies.

## PRODUCT EVALUATION

### SKILL TEST RECORD

**Evaluator note:** Rate the student on the following criteria by circling the appropriate numbers. Each criterion must receive a rating of "3" or higher to demonstrate student mastery. (See Key below.) A student who is unable to demonstrate mastery should review the material and submit another product for evaluation.

Criteria:

Even borders (parameters)	4	3	2	1
Joints flush and tight	4	3	2	1
Rows straight ( $\frac{1}{4}$ "	4	3	2	1
Nails properly spaced and set	4	3	2	1

## AVERAGE RATING

**Evaluator note:** To obtain an average rating for the Profile of Training Mastery, total the points in Product Evaluation and divide by the total number of criteria. Circle the rating on the Key.

## KEY

- 4 **Skilled** — Can perform job with no additional training
- 3 **Moderately Skilled** — Has performed job during training program; limited additional training may be required
- 2 **Limited Skill** — Has performed job during training program; additional training is required to develop skill
- 1 **Unskilled** — Is familiar with process, but is unable to perform job

## EVALUATOR'S COMMENTS

---

---

---

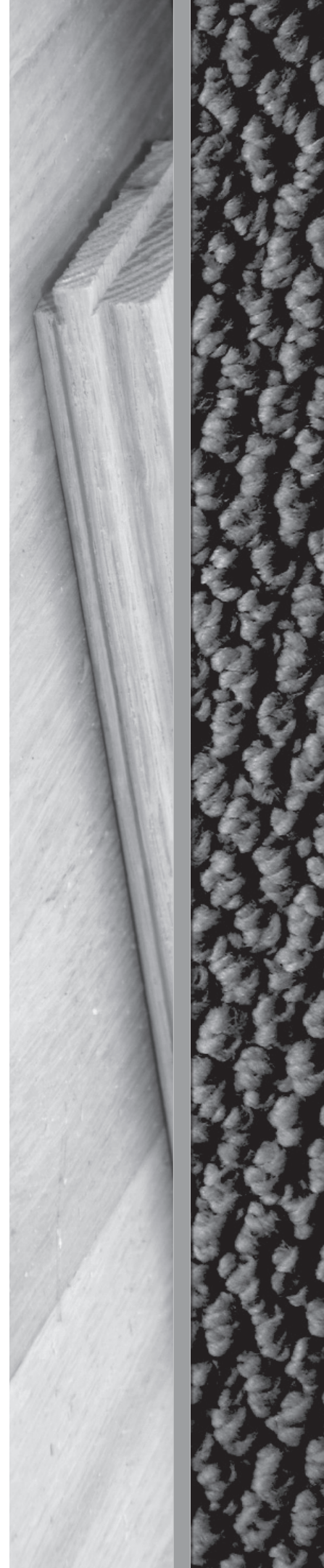

Student Name: \_\_\_\_\_ Score: \_\_\_\_\_

## INSTALL BLOCK FLOORING.

### BASIC SKILLS



### INTRODUCTION

There are several variations in the installation procedures for block flooring. Detailed installation instructions are usually furnished with the flooring. Follow the manufacturer's instructions if different from the procedure given in this job sheet

### EQUIPMENT AND SUPPLIES

- Adhesive and manufacturer's instructions
- Chalk line
- Flooring blocks and manufacturer's instructions
- Notched trowel
- Personal protective equipment
- Respiratory equipment as specified by the MSDS
- Steel tape

## PROCEDURE

Yes No

1. Put on personal protective equipment and clean work surface.

2. Determine starting point.

**NOTE ►** Some carpenters prefer to lay out actual flooring blocks when trying to determine the starting point.

A. Beginning at main entrance to room, measure distance to opposite wall.

**NOTE ►** Measure straight across the room to the opposite wall. If the opposite wall contains a doorway without a threshold, add one-half the thickness of the opening to the distance obtained, because flooring is normally laid to the midpoint of a doorway. If a threshold is used in the doorway, measure to the inside edge of the threshold.

B. Divide distance determined in step A by length of one flooring block.

**EXAMPLE:** If the distance to be floored in a room is 13' 10" and 9" x 9" blocks will be used, then  $13' 10" = 166"$ ,  $166" \div 9" = 18$  blocks, with a remainder of 4".

C. Divide any remainder found in step B by 2.

**EXAMPLE:** If there is a remainder of 4, then  $4" \div 2 = 2"$ .

D. If amount determined in step C is less than one-half length of one block, add one-half length of one block to determine the actual width of border pieces.

**EXAMPLE:** Since 2" is less than  $4\frac{1}{2}"$ , half the length of the 9" block, add one-half the length of the flooring, or  $2" + 4\frac{1}{2}" = 6\frac{1}{2}"$  width of border pieces.

E. Measure out from doorway a distance equal to width of border piece plus 4 whole blocks.

**EXAMPLE:** If the border piece is  $6\frac{1}{2}"$  and each block is 9" x 9", then  
 $6\frac{1}{2}" + 4(9) =$   
 $6\frac{1}{2}" + 36" = 42\frac{1}{2}"$ .

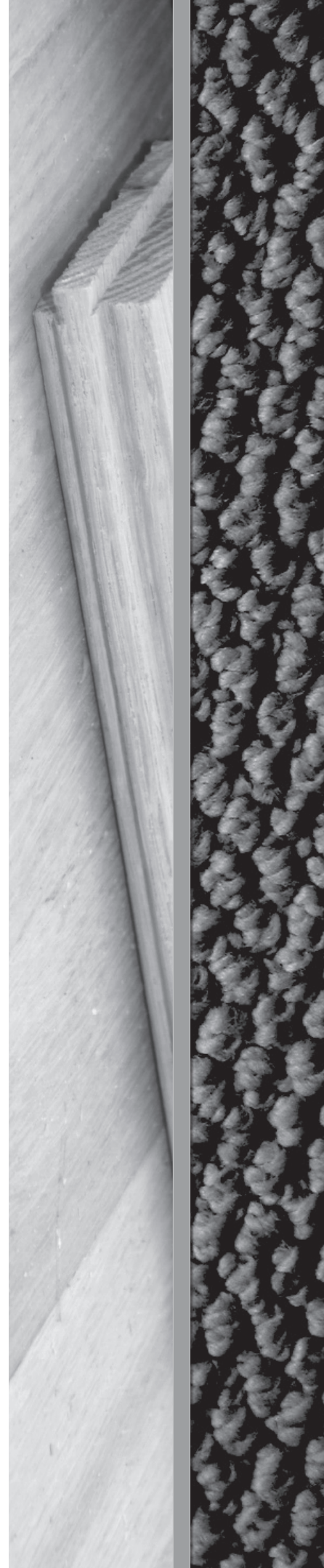

Yes No

F. At point determined in step E, snap a chalk line parallel to wall containing main entrance.

G. Repeat steps A through D to determine the number of whole blocks and width of border pieces between the other two walls of room.

H. Snap a chalk line square to the first line at a point even with the edge of a block midway between the end walls; use the 3-4-5 method to ensure that the lines are square. See Figure 156.

**NOTE** ► If there is an even number of whole blocks between the two walls, the line will be half way between the two walls. If there is an odd number of whole blocks between the two walls, then the second line will be along the edge of the middle, or one-half the width of a block from the center.

FIGURE 156

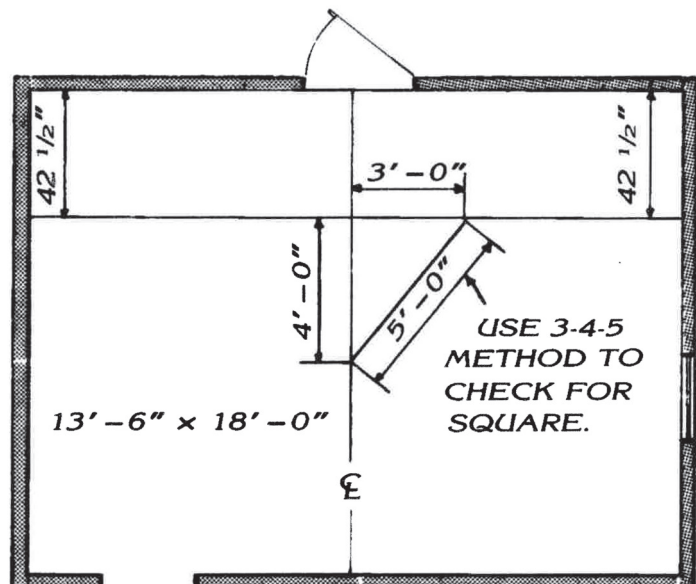



Yes No

3. Use notched trowel to spread adhesive in area at one corner of intersecting lines, being careful not to destroy chalk lines.

**NOTE** ▶ Do not spread more than you can use before the adhesive sets. See manufacturer's instructions.

4. Allow adhesive to set up in accordance with manufacturer's instructions.

5. Place first block in one of the right angles formed where the two lines intersect. See Figure 157.

**NOTE** ▶ Be sure that block is set even with the chalk line on the two sides.

6. Position second block for correct pattern, placing this block against first block and even with chalk line.

**NOTE** ▶ Flooring blocks are often laid so that wood grains in adjoining block are at right angles to each other.

FIGURE 157

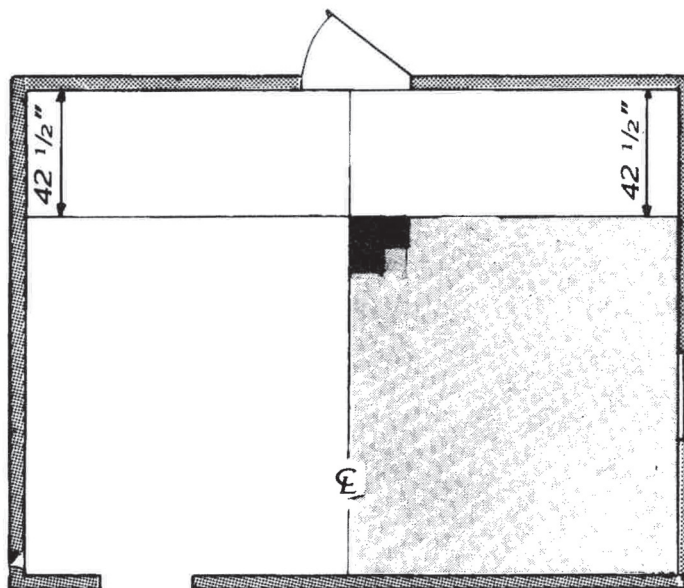

7. Continue laying blocks, working from chalk lines toward walls.

- 8. Spread adhesive and lay blocks to complete job, trimming blocks as necessary.

**NOTE ►** Cut blocks away from work area to avoid getting sawdust on adhesive.

- 9. As you go, wipe off any adhesive that may have smeared on blocks.

- 10. Clean up area and put away equipment and supplies.

## PRODUCT EVALUATION

### SKILL TEST RECORD

**Evaluator note:** Rate the student on the following criteria by circling the appropriate numbers. Each criterion must receive a rating of “3” or higher to demonstrate student mastery. (See Key below.) A student who is unable to demonstrate mastery should review the material and submit another product for evaluation.

Criteria:

Row straight ( $\frac{1}{4}$ "	4	3	2	1
Border tiles of equal size ( $\pm \frac{1}{4}$ "	4	3	2	1
Blocks cleaned of adhesive	4	3	2	1

### AVERAGE RATING

**Evaluator note:** To obtain an average rating for the Profile of Training Mastery, total the points in Product Evaluation and divide by the total number of criteria. Circle the rating on the Key.

### KEY

- 4 Skilled** — Can perform job with no additional training
- 3 Moderately Skilled** — Has performed job during training program; limited additional training may be required
- 2 Limited Skill** — Has performed job during training program; additional training is required to develop skill
- 1 Unskilled** — Is familiar with process, but is unable to perform job

## EVALUATOR'S COMMENTS

---

---

---

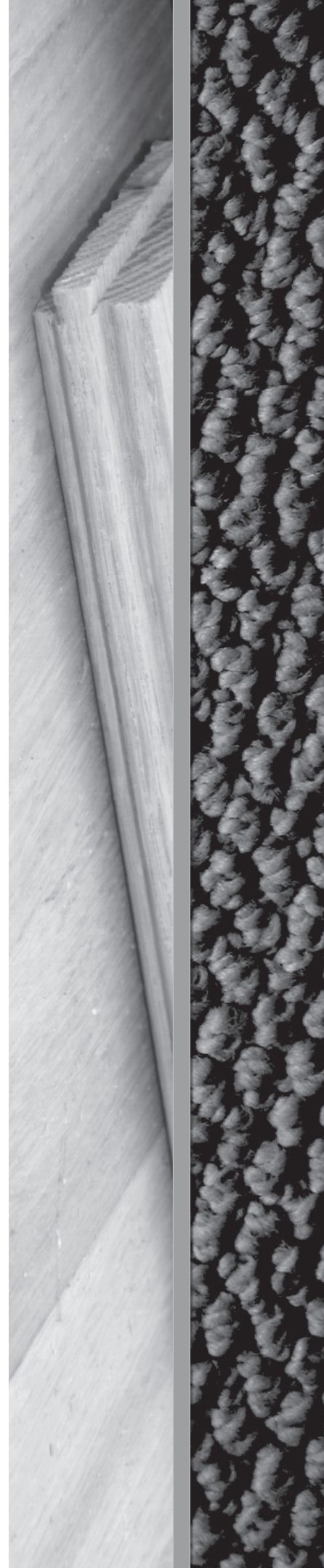

# **ROOF FINISHES**

## **CARPENTRY SERIES**





ROOF FINISHES  
CARPENTRY SERIES  
**JOB SHEET**

**1**

Student Name: \_\_\_\_\_ Score: \_\_\_\_\_

**USE A ROOFER'S HATCHET PROPERLY.**

**BASIC SKILLS**



READING



EMPLOYABILITY

**INTRODUCTION**

A roofer's hatchet is used to secure composite and wood shingles to a roof. It is one tool that the carpenter will use extensively when roofing. Knowing how to use this tool properly will make the roofing process more efficient and safe.

**EQUIPMENT AND SUPPLIES**

- Asphalt shingles
- Personal protective equipment
- Plywood
- Roofer's hatchet
- Roofing nails

**PROCEDURE**

Yes No

1. Put on all personal protective equipment.

Yes No

2. Lay a sheet of plywood on a flat surface to simulate a roof deck.

**NOTE** ► Place the plywood on a flat surface that will NOT be harmed by the nails protruding through the plywood.

3. Grasp the hatchet handle firmly near the end. See Figure 158.

4. Position a shingle on the plywood.

5. Rest the face of the hatchet head on the nail as you position the nail point on the shingle.

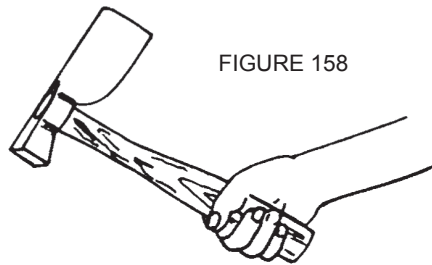

FIGURE 158

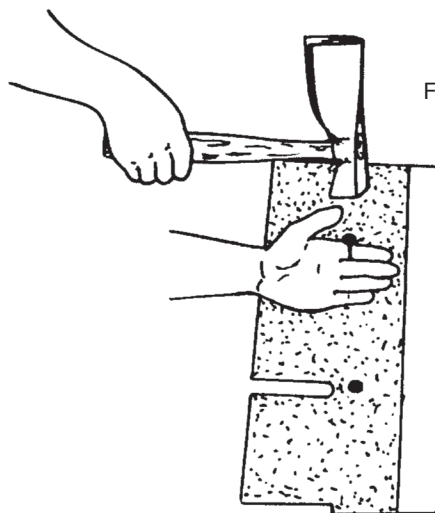

FIGURE 159

6. Place the nail between the index and middle fingers.

7. Lean your head slightly to avoid the upper swing of the hatchet.

8. Raise the hatchet head and lightly tap the nail to get it started.

**NOTE** ► This maneuver is accomplished through the wrist, elbow, and shoulder with one or all being used according to the strength of the blow to be struck.

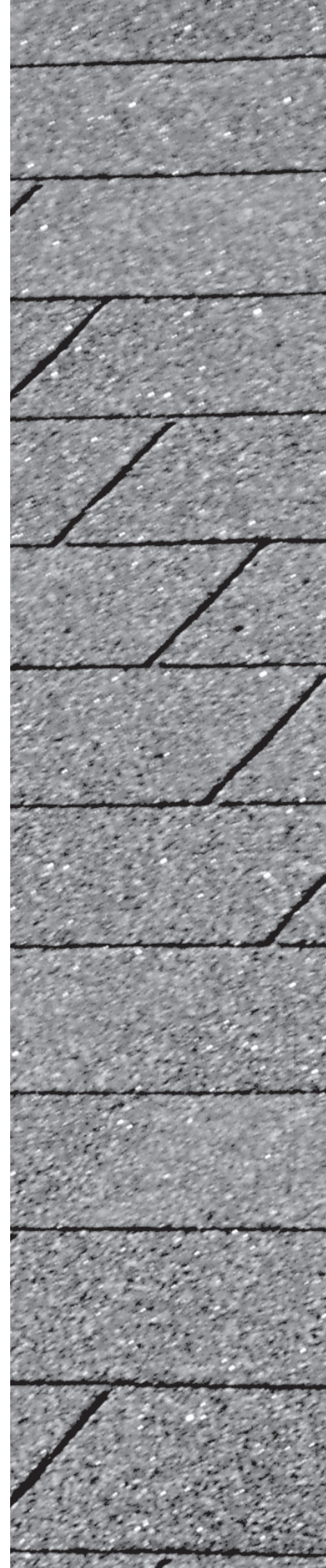



Yes No



9. With the nail started, pull your hand safely away from the nail.



10. Strike the nail squarely to drive the nail into the shingle and plywood.

**CAUTION:** Do not overdrive the nail head. It should be flush with the shingle surface and not break the shingle.



11. Have your instructor check your work.



12. Clean up the area and put away the equipment and supplies.

FIGURE 160

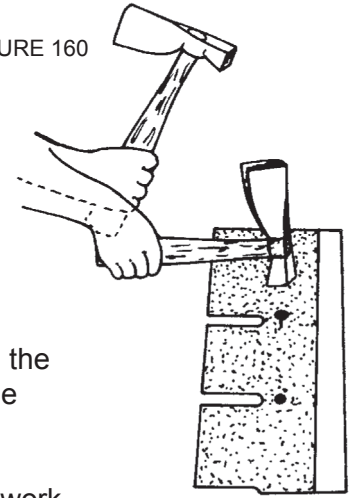

## PRODUCT EVALUATION

### SKILL TEST RECORD

**Evaluator note:** Rate the student on the following criteria by circling the appropriate numbers. Each criterion must receive a rating of “3” or higher to demonstrate student mastery. (See Key below.) A student who is unable to demonstrate mastery should review the material and submit another product for evaluation.

Criteria:

Used safety equipment properly	4	3	2	1
Grasped hatchet by end	4	3	2	1
Started nail properly	4	3	2	1
Drove nail straight	4	3	2	1
Did not overdrive nail head	4	3	2	1



## AVERAGE RATING

**Evaluator note:** To obtain an average rating for the Profile of Training Mastery, total the points in Product Evaluation and divide by the total number of criteria. Circle the rating on the Key.

## KEY

- 4 **Skilled** — Can perform job with no additional training
- 3 **Moderately Skilled** — Has performed job during training program; limited additional training may be required
- 2 **Limited Skill** — Has performed job during training program; additional training is required to develop skill
- 1 **Unskilled** — Is familiar with process, but is unable to perform job

## EVALUATOR'S COMMENTS

---

---

---

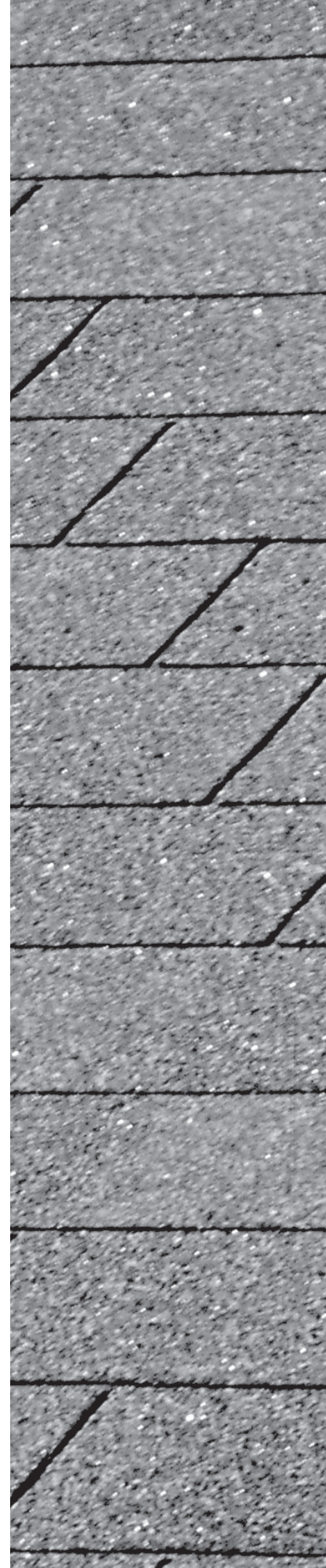



# ROOF FINISHES CARPENTRY SERIES JOB SHEET **2**

Student Name: \_\_\_\_\_ Score: \_\_\_\_\_

## USE A PNEUMATIC FASTENER.

### BASIC SKILLS



### INTRODUCTION

A pneumatic fastener uses compressed air to force the fastener into the shingle. It can be very dangerous if not properly used. Always read the air compressor's manufacturer's instruction manual before adjusting the regulator for correct pressure specifications. Becoming familiar with its use and knowing how to use the fastener properly will make the roofing process more efficient and safe.

### EQUIPMENT AND SUPPLIES

- Electric air compressor with air hose
- Manufacturer's instruction manual
- Personal protective equipment
- Pneumatic fastener
- Recommend fasteners (nails)
- Two 2 x 4s, 4' long

## PROCEDURE

Yes No

- |                          |                          |  |
|--------------------------|--------------------------|--|
| <input type="checkbox"/> | <input type="checkbox"/> | 1. Put on all personal protective equipment.   |
| <input type="checkbox"/> | <input type="checkbox"/> | 2. Plug the air compressor into a power source.  |
| <input type="checkbox"/> | <input type="checkbox"/> | 3. Start the air compressor.   |
| <input type="checkbox"/> | <input type="checkbox"/> | 4. Adjust the regulator to manufacturer's specifications.  |
| <input type="checkbox"/> | <input type="checkbox"/> | 5. Load the fastener with nails.<br><b>CAUTION:</b> Never load the fastener with nails while it is still attached to the compressor. |
| <input type="checkbox"/> | <input type="checkbox"/> | 6. Hold the fastener with the discharge end pointed down and away from anyone.   |
| <input type="checkbox"/> | <input type="checkbox"/> | 7. Connect the air hose to the fastener.<br><b>CAUTION:</b> Be sure that both hands are clear of the discharge end.                  |
| <input type="checkbox"/> | <input type="checkbox"/> | 8. Check with your instructor for approval before using fastener.  |
| <input type="checkbox"/> | <input type="checkbox"/> | 9. Check to see that everyone is clear of the fastener.  |
| <input type="checkbox"/> | <input type="checkbox"/> | 10. Position the two pieces of stock to be fastened together.  |
| <input type="checkbox"/> | <input type="checkbox"/> | 11. Position the fastener firmly on the stock to be connected and pull the trigger.  |
| <input type="checkbox"/> | <input type="checkbox"/> | 12. Continue to discharge the nails until the project is complete.   |
| <input type="checkbox"/> | <input type="checkbox"/> | 13. Disconnect the air hose from the fastener.   |
| <input type="checkbox"/> | <input type="checkbox"/> | 14. Turn the air compressor off and disconnect it from the power source.   |
| <input type="checkbox"/> | <input type="checkbox"/> | 15. Have your instructor check your work.  |
| <input type="checkbox"/> | <input type="checkbox"/> | 16. Clean up the area and put away the equipment and supplies.   |

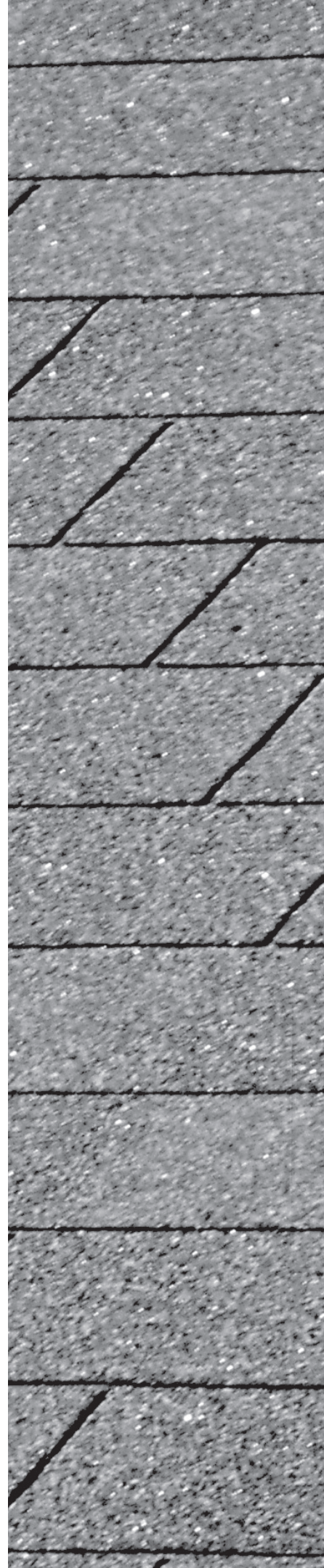



## PRODUCT EVALUATION

### SKILL TEST RECORD

**Evaluator note:** Rate the student on the following criteria by circling the appropriate numbers. Each criterion must receive a rating of “3” or higher to demonstrate student mastery. (See Key below.) A student who is unable to demonstrate mastery should review the material and submit another product for evaluation.

Criteria:

Used safety equipment properly	4	3	2	1
Observed safety guidelines	4	3	2	1
Loaded nails properly	4	3	2	1
Connected and disconnected from power source at correct time	4	3	2	1
Completed task	4	3	2	1

### AVERAGE RATING

**Evaluator note:** To obtain an average rating for the Profile of Training Mastery, total the points in Product Evaluation and divide by the total number of criteria. Circle the rating on the Key.

### KEY

- 4 Skilled** — Can perform job with no additional training
- 3 Moderately Skilled** — Has performed job during training program; limited additional training may be required
- 2 Limited Skill** — Has performed job during training program; additional training is required to develop skill
- 1 Unskilled** — Is familiar with process, but is unable to perform job

**EVALUATOR'S COMMENTS**

---

---

---

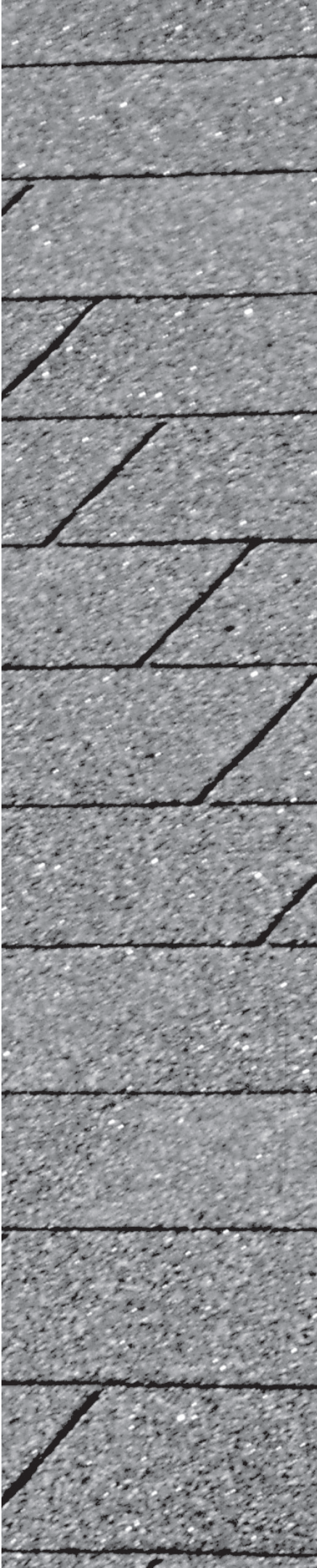

Student Name: \_\_\_\_\_ Score: \_\_\_\_\_

**APPLY ASPHALT SHINGLES WITH A 5" EXPOSURE.**

**BASIC SKILLS**



**INTRODUCTION**

Asphalt shingles are laid so they will overlap and cover each other in order to shed water properly. In addition the underlayment, drip edge and flashing should be installed before covering with shingles. Knowing how to apply asphalt shingles correctly will provide a sound structure and a professional job.

**EQUIPMENT AND SUPPLIES**

- Margin trowel
- Metal drip edge
- Personal protective equipment
- Plastic cement
- Prefabricated pipe flashing (single piece)
- Roofer's hatchet
- Roofing nails
- Shingles and manufacturer's instructions
- Underlayment material
- Utility knife

## PROCEDURE

### A. For applying the underlayment over the sheathing (dry-in)

Yes No

1. Put on personal protective equipment.
2. Apply the full width of underlayment (3') along the eave, placing the lower edge and end of the underlayment flush with the sheathing over the eaves and rake.
3. Nail the underlayment  $\frac{1}{2}$ " to  $\frac{3}{4}$ " down and in a straight line from the top edge of the underlayment, spacing the nails about 18" apart.
- NOTE** ▶ This nailing pattern will secure the top edge of the underlayment until the next underlayment course is laid.
4. Nail the underlayment about 1" from the edge of the sheet along the eaves and rake, spacing the nails about 12" apart. See Figure 161.
- NOTE** ▶ Lap the underlayment 4" if splices are required

FIGURE 161

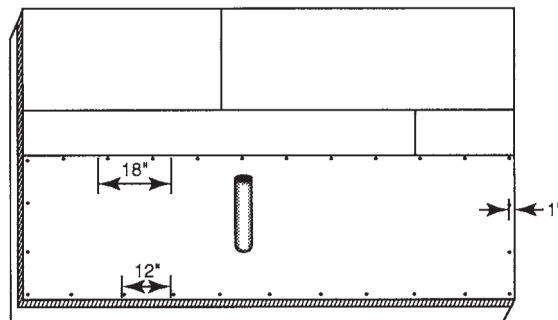

5. Apply a second underlayment course, following the procedures in steps 3 and 4. Be sure to lap the second course 2" down over the first course.
6. Continue applying the underlayment, following the procedures in steps 3 and 4 while maintaining proper laps until the entire roof is covered. See Figure 162.

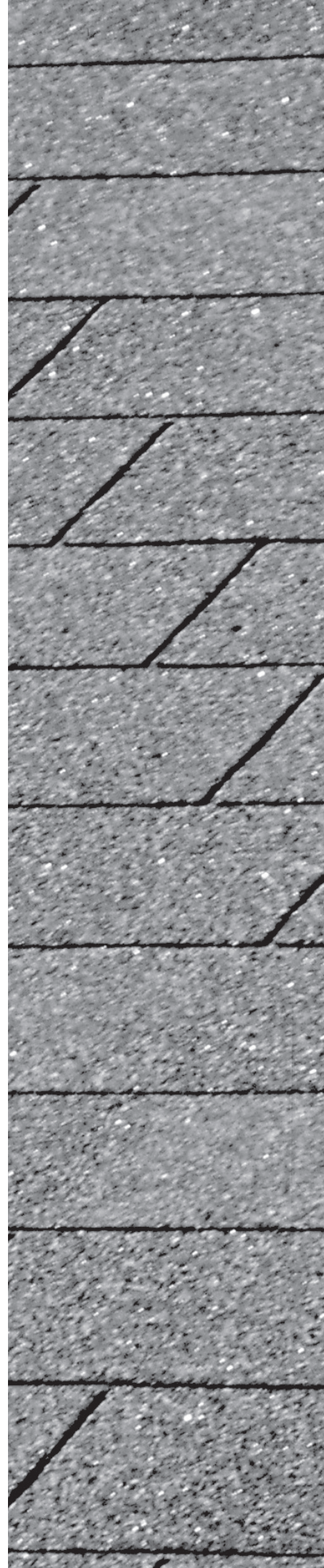
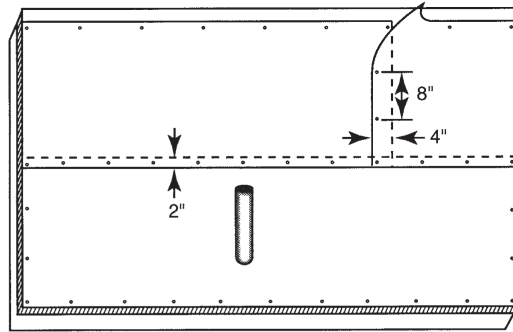



FIGURE 162



**B. For applying shingles.**

Yes No

1. Install the metal drip edge.

A. Put one nail about 1/2" in from center at each end of the drip edge and another nail down about 3/4" from the top edge.

B. Space the nails about 10" apart down the length of the drip edge.

2. Apply a double starter course. See Figure 163.

A. Apply the first row of double starter course so that the top edge is down and even with the edge or eave.

B. Apply a second row of double starter course, overlapping the bottom edge of the eave as recommended by the manufacturer.

FIGURE 163

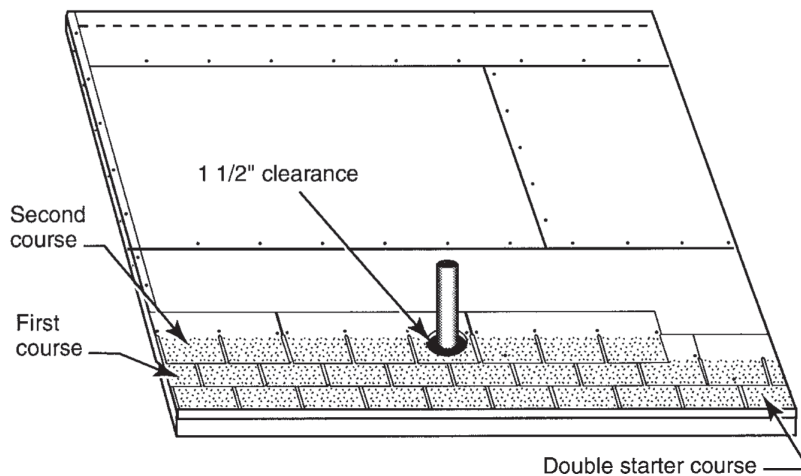



Yes No

3. Apply the first course of singles. See Figure 163.
- A. Determine the pattern to be used.  
EXAMPLES: One-half tab break, one-third tab break, 5" break
- B. Follow the manufacturer's recommendations for layout and installation.
- NOTE** ▶ Often manufacturers will give installation instructions on the package. These instructions should be followed exactly. Use the recommended nailing pattern, checking to see whether or not different nailing patterns are required for different pitches. Also, manufacturers may specify a gap between abutting edges of shingles or other procedures.
4. Apply a second course of shingles, following the procedure determined for the first course until you reach the vent pipe.
5. Make a cutout for the vent pipe and install the flashing.
- A. Cut and fit the shingle around the vent pipe, allowing about 1½" clearance. See Figure 163.
- B. Apply the shingle and nail it in place. See Figure 164.

FIGURE 164

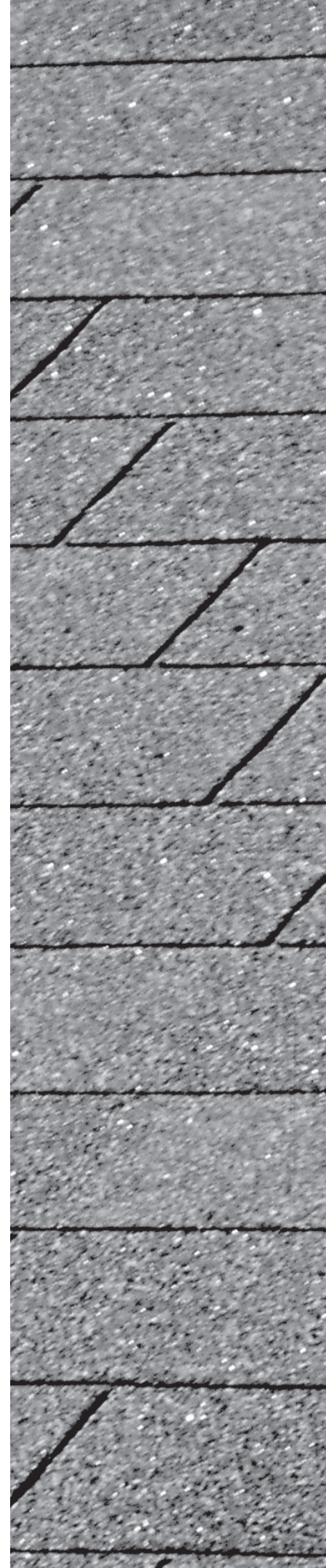
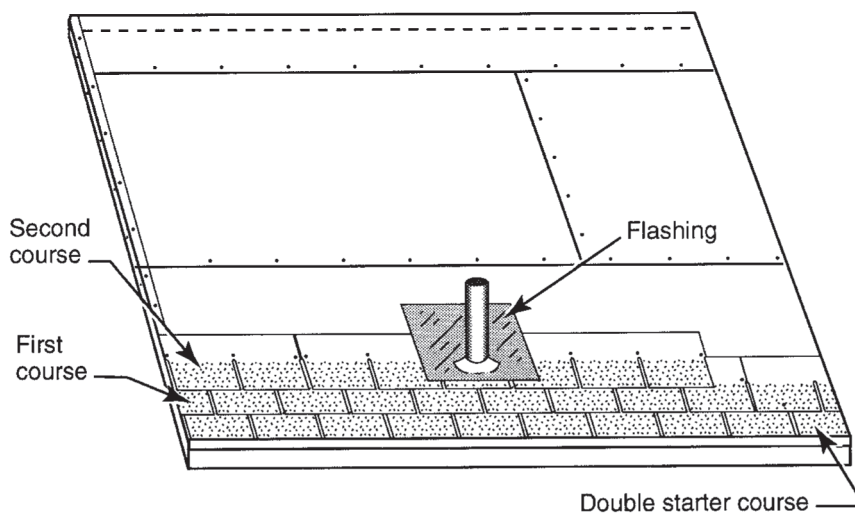



Yes No

C. Slide the flashing over the pipe so that it fits firmly, with the top edge of flashing flange resting on the underlayment and bottom edge of the flashing flange resting over the second course of shingles. See Figure 164.

6. Finish the second course of shingles.

7. Apply the third course of shingles, following the procedure determined for the first course until you reach the vent pipe.

**NOTE** ▶ While you are fitting shingles around the vent pipe, another person may continue to apply the shingles by stair-stepping them up the roof's edge. See Figure 165.

8. Make a cutout for the vent pipe by cutting and trimming the shingle to fit around the vent pipe in proper alignment with the other shingles. See Figure 165.

**NOTE** ▶ When nailing the shingle around the vent pipe, do NOT nail within 6" of the vent pipe.

FIGURE 165

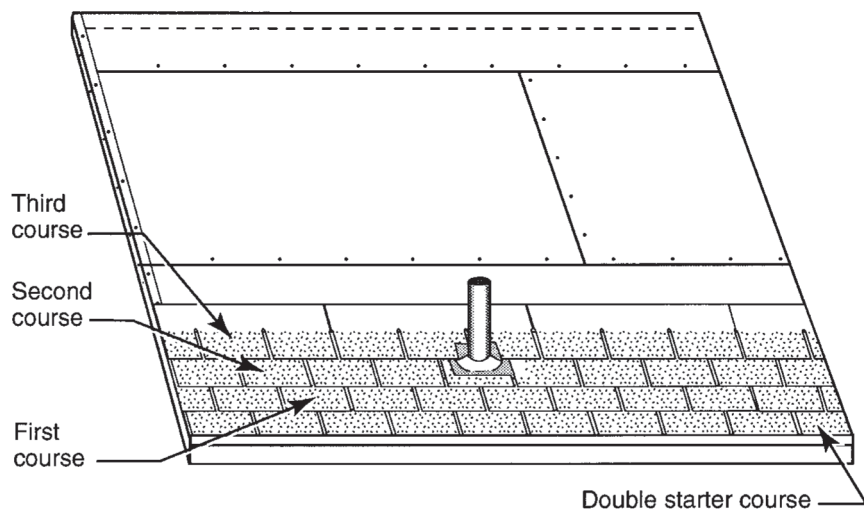

9. Finish the third course of shingles.

10. Continue applying the courses, including the ridge shingles until the project is completed. See Figure 166.

FIGURE 166

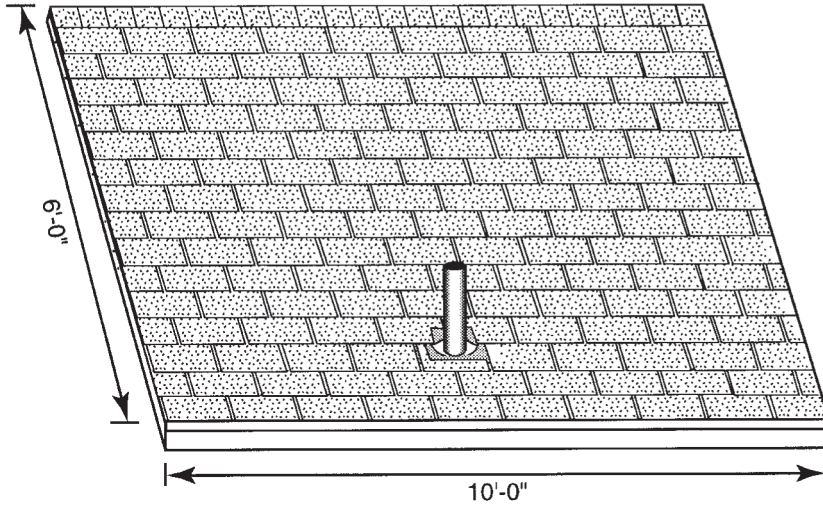

Yes No

11. Have your instructor check your work.
12. Clean up the area and put away the equipment and supplies.

## PRODUCT EVALUATION

### SKILL TEST RECORD

**Evaluator note:** Rate the student on the following criteria by circling the appropriate numbers. Each criterion must receive a rating of “3” or higher to demonstrate student mastery. (See Key below.) A student who is unable to demonstrate mastery should review the material and submit another product for evaluation.

Criteria:

Used equipment properly	4	3	2	1
Underlayment flush (- ¼")	4	3	2	1
Nail spacing correct (18" ± ¼")	4	3	2	1
First row even (⅙" of eave)	4	3	2	1
Vent cutout clearance correct (⅛")	4	3	2	1
Course of shingles straight (¼")	4	3	2	1

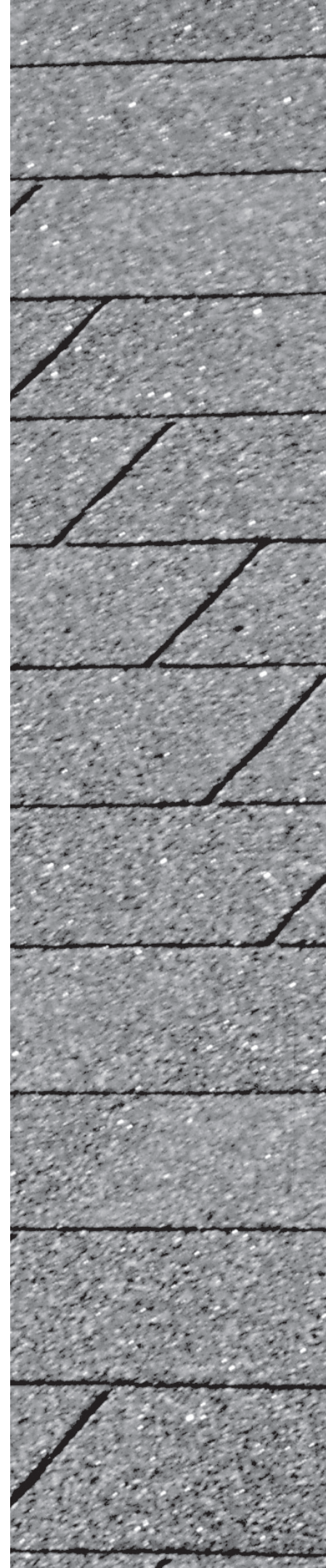



## AVERAGE RATING

**Evaluator note:** To obtain an average rating for the Profile of Training Mastery, total the points in Product Evaluation and divide by the total number of criteria. Circle the rating on the Key.

## KEY

- 4 Skilled** — Can perform job with no additional training
- 3 Moderately Skilled** — Has performed job during training program; limited additional training may be required
- 2 Limited Skill** — Has performed job during training program; additional training is required to develop skill
- 1 Unskilled** — Is familiar with process, but is unable to perform job

## EVALUATOR'S COMMENTS

---

---

---



ROOF FINISHES  
CARPENTRY SERIES  
**JOB SHEET**

**4**

Student Name: \_\_\_\_\_ Score: \_\_\_\_\_

**APPLY WOOD SHINGLES WITH A 5" EXPOSURE OVER SPACED SHEATHING**

**BASIC SKILLS**



READING



MATHEMATICS



CRITICAL  
THINKING



EMPLOYABILITY

**INTRODUCTION**

The choice of roofing material depends on cost, roof slope, wind resistance, expected service life, and local climate. Also because of the large amount of exposure, appearance is a large factor. Some structures will require finishing the roof with wood shingles. Knowing how to apply the wood shingles is a critical step to becoming a professional carpenter.

**EQUIPMENT AND SUPPLIES**

- Metal drip edge
- Personal protective equipment
- Roofer's hatchet
- Roofing nails
- Utility knife
- Wood shingles and manufacturer's instructions

Yes No

- |                          |                          |   |
|--------------------------|--------------------------|---|
| <input type="checkbox"/> | <input type="checkbox"/> | 1. Put on personal protective equipment.  |
| <input type="checkbox"/> | <input type="checkbox"/> | 2. Install a metal drip edge.   |
| <input type="checkbox"/> | <input type="checkbox"/> | A. Put one nail about $\frac{1}{2}$ " in from the center at each end of the drip edge and another nail down about $\frac{3}{4}$ " from the top edge.                    |
| <input type="checkbox"/> | <input type="checkbox"/> | B. Nail the remainder of the drip edge down, spacing nails about 10" apart down the length of the drip edge.  |
| <input type="checkbox"/> | <input type="checkbox"/> | 3. Apply the double starter course.   |
| <input type="checkbox"/> | <input type="checkbox"/> | A. Apply the first row of the double starter course, allowing 1" overhang at the eave and leaving $\frac{1}{4}$ " to $\frac{3}{8}$ " between the edges of the shingles. |

FIGURE 167

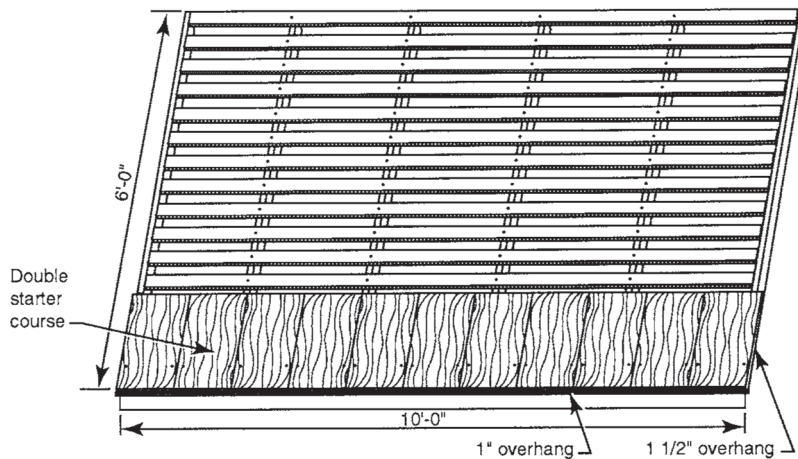

- |                          |                          |  |
|--------------------------|--------------------------|--|
| <input type="checkbox"/> | <input type="checkbox"/> | B. Nail each shingle, using two nails and spacing the nails in from the edge of the shingle $\frac{3}{4}$ " and about $1\frac{1}{2}$ " to the butt line of the next course.                          |
|                          |                          | <b>NOTE</b> ▶ Drive the nails flush with the shingle surface. Do not damage the surface of the shingle around the nail.  |
| <input type="checkbox"/> | <input type="checkbox"/> | C. Apply the second row the double starter course over the first row, spacing the shingles where the joints in the second row are offset at least $1\frac{1}{2}$ " from the joints in the first row. |

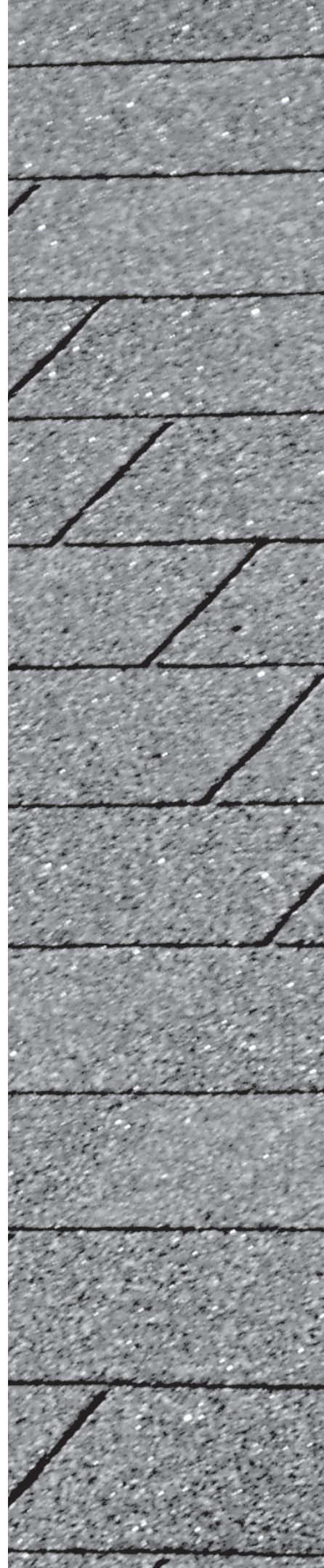



Yes No

4. Apply the first course of shingles, allowing for 5" exposure and leaving  $\frac{1}{4}$ " to  $\frac{3}{8}$ " between the edges of the shingles.

5. Continue applying the course, following the procedure in step 4 until the job is complete. See Figures 168 and 169.

FIGURE 168

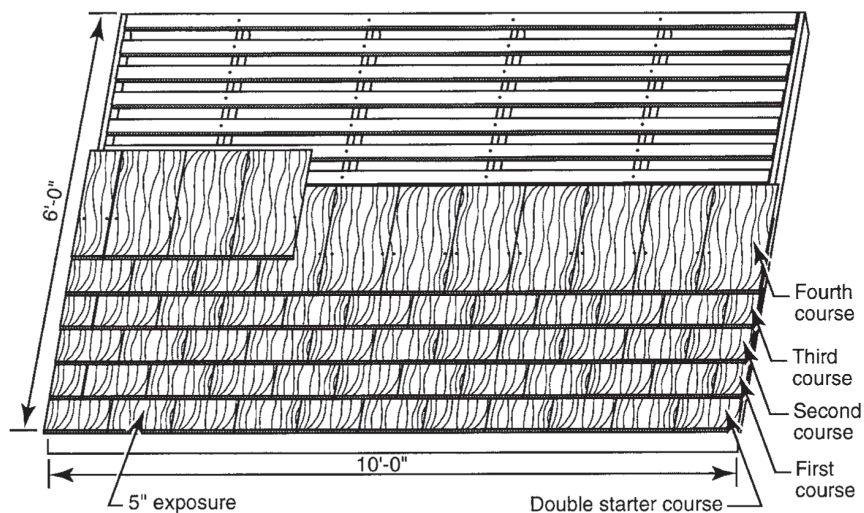
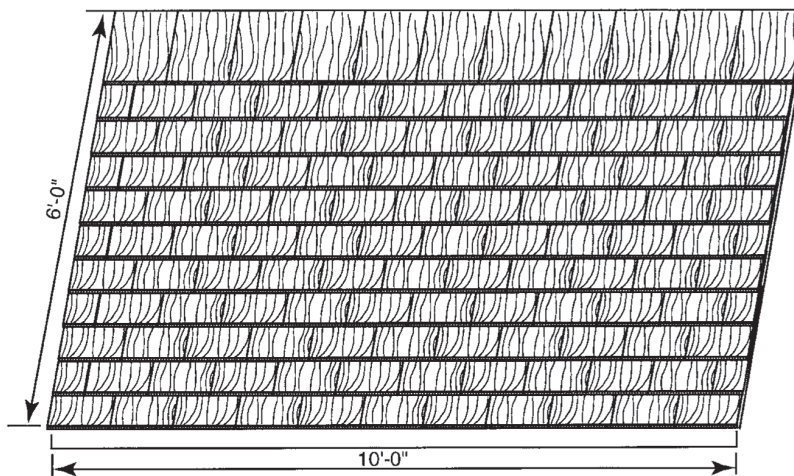

FIGURE 169



6. Have your instructor check your work.

7. Clean up the area and put away the equipment and supplies.



# PRODUCT EVALUATION

## SKILL TEST RECORD

**Evaluator note:** Rate the student on the following criteria by circling the appropriate numbers. Each criterion must receive a rating of “3” or higher to demonstrate student mastery. (See Key below.) A student who is unable to demonstrate mastery should review the material and submit another product for evaluation.

Criteria:

Used equipment properly	4	3	2	1
Nail spacing correct ( $\pm \frac{1}{4}$ "	4	3	2	1
Correct starter course overhang ( $\pm \frac{1}{8}$ "	4	3	2	1
Exposure proper ( $\pm \frac{1}{4}$ "	4	3	2	1
Nails flush	4	3	2	1
No damage to shingle surface	4	3	2	1

## AVERAGE RATING

**Evaluator note:** To obtain an average rating for the Profile of Training Mastery, total the points in Product Evaluation and divide by the total number of criteria. Circle the rating on the Key.

## KEY

- 4 Skilled** — Can perform job with no additional training
- 3 Moderately Skilled** — Has performed job during training program; limited additional training may be required
- 2 Limited Skill** — Has performed job during training program; additional training is required to develop skill
- 1 Unskilled** — Is familiar with process, but is unable to perform job

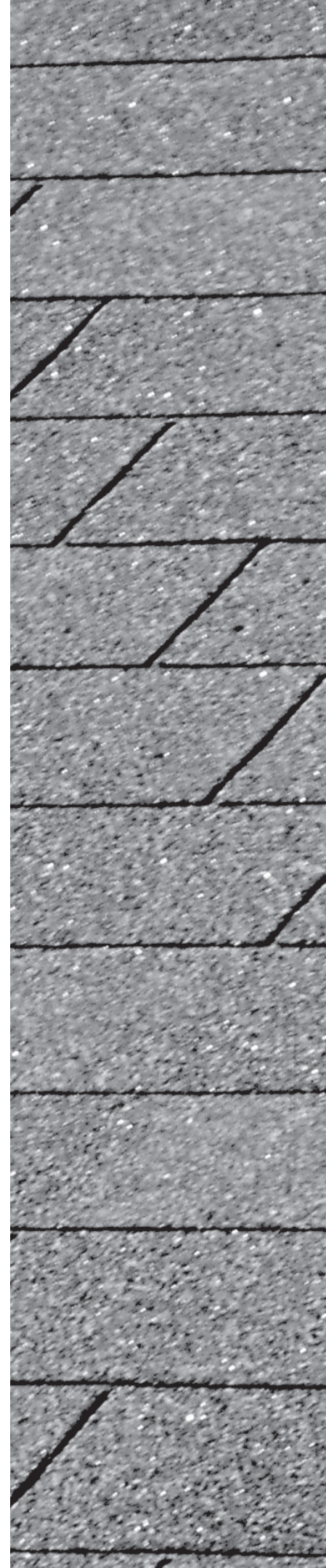



## EVALUATOR'S COMMENTS

---

---

---



# **COLUMN FORMS**

**CARPENTRY SERIES**



Student Name: \_\_\_\_\_ Score: \_\_\_\_\_

## CONSTRUCT AND STRIP FORMS FOR A SQUARE COLUMN.

### BASIC SKILLS



### INTRODUCTION

This exercise provides practice in building and stripping forms for a square column. Both job-built and patented forms are discussed. Patented forms reduce the effort of form construction through prefabrication of form components. Their on-site assembly is similar to that of job-built forms with the exception of cutting form material.

### EQUIPMENT AND SUPPLIES

- 2 x 4s for studs and template
- 6d duplex, 16d duplex, and concrete nails or powder-actuated fastener
- 30" Hand level
- Appropriate column clamps
- Chalk line
- Circular saw and extension cord
- Electric drill and bits
- Folding rule or steel tape
- Form release agent and mop, brush, or sprayer
- Framing square

### Words You Should Know

#### Patented forms

premanufactured forms

#### Template

a gauge used as a pattern for copying or making identical parts

#### Spalling

breaking apart in chips, scales, or slabs

- Hammer
- Handsaw
- Personal protective equipment
- Plywood sheathing
- Pry bar
- String line

## PROCEDURE

Yes No

- 1. Put on personal protective equipment.
- 2. Use building plan to determine size of column.
- 3. Cut column sides (plywood sheathing) to size. See Figure 170.

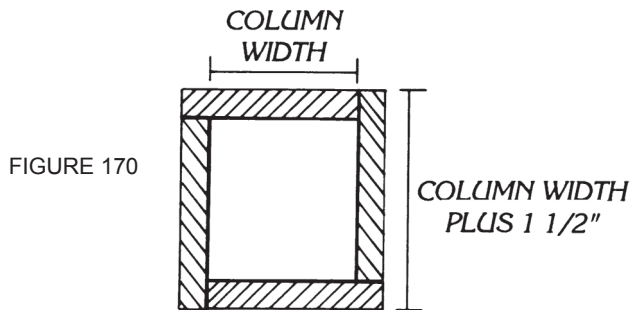

- 4. Cut column studs.
 

**NOTE ►** Studs will be the same length as the column side.
- 5. Assemble column sides. See Figure 171.

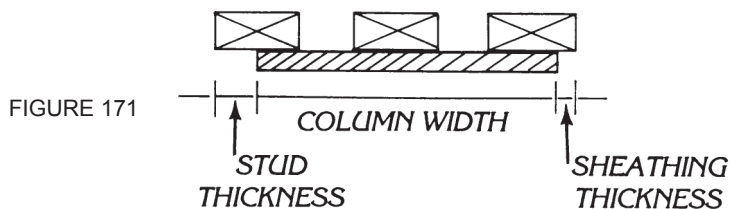



Yes No



6. Lay out column center lines. See Figure 172.

**NOTE** ▶ Extend lines so they will show on outside of column forms and template.

FIGURE 172

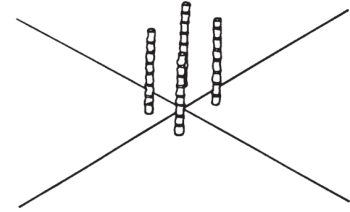

7. Construct template for base of column.

**NOTE** ▶ Template should be the same size as the outside of the column form.



8. Use concrete nails or powder-actuated fastener to nail template to floor. See Figure 173.

**NOTE** ▶ As an alternate method, drill a pilot hole and pin the template with nails. This will prevent the concrete from spalling.

**CAUTION:** Use powder-actuated fastener only if certified in its use. Follow manufacturer's instructions and safety precautions before loading or operation.

FIGURE 173

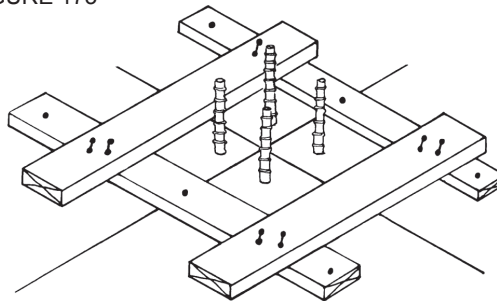

9. Refer to column clamp manufacturer for proper clamp spacing.



10. Lay out column clamp spacing on form sides.

**NOTE** ▶ All steel must be completely in place and forms should be covered with form oil.



11. Stand opposing column sides in template and nail corner studs to duplex nails.



12. Stand the other two sides in template and nail as in step 11.



Yes No

13. Drive 16d duplex nail at each column clamp spacing mark. See Figure 174.

**NOTE** ▶ These nails serve to support the clamps during installation. Check the type of clamp being used for side locations of nails.

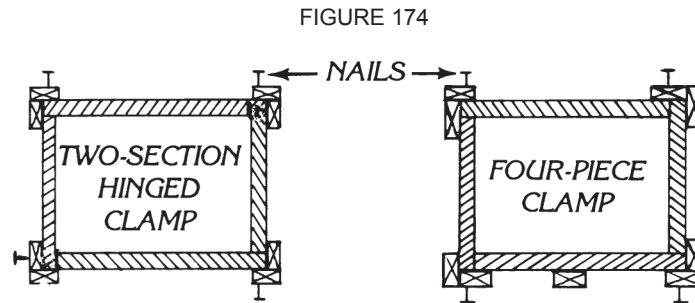

14. Lay sections of column clamps on nails and secure together.

15. Install braces for columns.

- A. Nail braces to two sides of column near top of column.
- B. Nail block in position to floor so that lower end of brace can be nailed to block.

16. Plumb column in both directions and then nail bracing to blocks on floor.

**NOTE** ▶ When several columns are set in a straight line, alignment is made by running a pair of stringers at the top of the columns from one column to the next. One brace is needed to plumb the column on the opposite side.

17. Recheck work for plumb and accuracy.

18. Ask your instructor to evaluate your form.

19. Disassemble the form in the reverse order of its construction.

20. This concludes the job sheet for the construction of a square column. Consult with your instructor for the need to apply form oil.

21. Clean up area and put up equipment and supplies.



## PRODUCT EVALUATION

### SKILL TEST RECORD

**Evaluator note:** Rate the student on the following criteria by circling the appropriate numbers. Each criterion must receive a rating of "3" or higher to demonstrate student mastery. (See Key below.) A student who is unable to demonstrate mastery should review the material and submit another product for evaluation.

Criteria:

Safety equipment used properly	4	3	2	1
Plumb ( $\frac{1}{4}$ "	4	3	2	1
Square clamp spacing proper	4	3	2	1
Braces secure	4	3	2	1
Form dimensions correct ( $\frac{1}{8}$ "	4	3	2	1

### AVERAGE RATING

**Evaluator note:** To obtain an average rating for the Profile of Training Mastery, total the points in Product Evaluation and divide by the total number of criteria. Circle the rating on the Key.

### KEY

- 4 Skilled** — Can perform job with no additional training
- 3 Moderately Skilled** — Has performed job during training program; limited additional training may be required
- 2 Limited Skill** — Has performed job during training program; additional training is required to develop skill
- 1 Unskilled** — Is familiar with process, but is unable to perform job

## EVALUATOR'S COMMENTS

---

---

---



Student Name: \_\_\_\_\_ Score: \_\_\_\_\_

## SET AND STRIP A ROUND COLUMN.

### BASIC SKILLS



### INTRODUCTION

During this exercise you will set a precast fiberboard tube in preparation of pouring a round concrete column. The job sheet describes the use of reinforcing steel. Your instructor may ask that reinforcing steel not be used in the instructional environment.

### EQUIPMENT AND SUPPLIES

- 2 x 4s for braces and templates
- 16d and concrete nails or powder-actuated fastener
- 30" Hand level
- Circular saw and extension cord
- Claw hammer
- Fiberboard tube, 24" x 16"
- Framing square
- Handsaw
- Personal protective equipment
- Plumb bob
- Steel tape

## PROCEDURE

Yes No

1. Put on personal protective equipment.
2. Lay out the column using a framing square. See Figure 175.

FIGURE 175

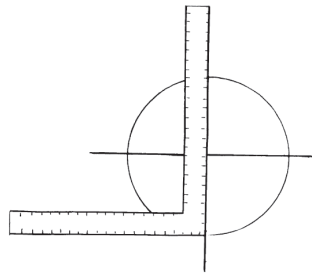

A. Establish a center line.

B. Mark the center lines on the floor using a framing square.

C. Mark the center lines on the column form at the top and bottom.

3. Prepare the form for setting.

A. Cut 2 x 4s and build a template. See Figure 176.

FIGURE 176

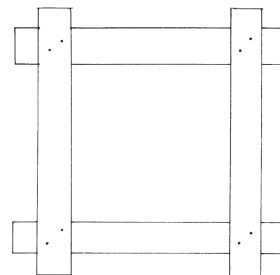

B. Nail templates together and mark center lines on the one that will be used at the bottom.

**NOTE** ▶ The number of templates depends on the size and height of the form.

4. Set the form.

**NOTE** ▶ A scaffold will have to be set up beside the column location in order to lift the form over the reinforcing steel. See Figure 177.

A. Lift the form up and over the steel and carefully work it down to the floor. See Figure 177.

FIGURE 177

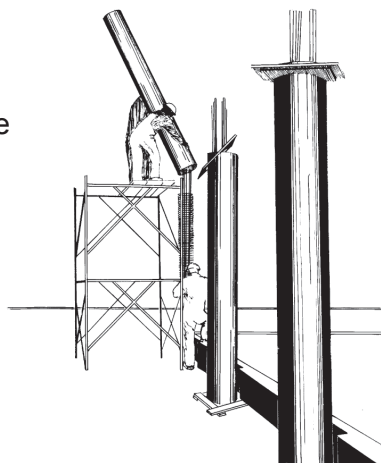

B. Slip templates over the form; toenail one at the top and one at the bottom of the form.



Yes No

C. Line up center marks on the bottom template with marks on the floor; nail the bottom template to the floor with concrete nails or a powder-actuated fastener.

**CAUTION:** Use of powder-actuated fastener requires user to be safety certified. Follow manufacturer's instructions and safety precautions before loading or operation.

D. Plumb and brace the form. See Figure 178.

**NOTE** ► Two braces will be necessary in order to brace in two different directions.

FIGURE 178

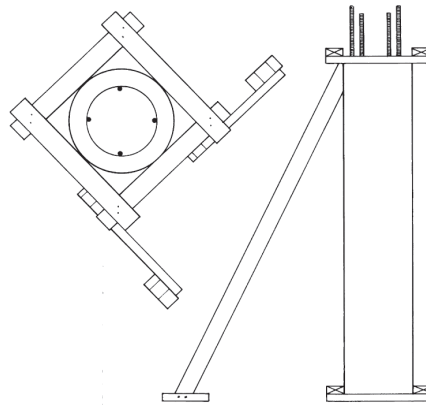

E. Brace to the top template.

F. Nail the top of the brace to the stud.

G. Plumb the column in both directions using a plumb bob.

H. Nail the brace to 2 x 4s that have been nailed to the floor.

I. Recheck your work for plumb and accuracy.

5. Ask your instructor to check your work.

6. Strip the form in the reverse order of its construction.

7. Clean up area and put up equipment and supplies.

# PRODUCT EVALUATION

## SKILL TEST RECORD

**Evaluator note:** Rate the student on the following criteria by circling the appropriate numbers. Each criterion must receive a rating of “3” or higher to demonstrate student mastery. (See Key below.) A student who is unable to demonstrate mastery should review the material and submit another product for evaluation.

Criteria:

Safety equipment used properly	4	3	2	1
Form plumb ( $\frac{1}{4}$ " )	4	3	2	1
Templates secured and centered	4	3	2	1
Scaffold used safely	4	3	2	1
Braces secure	4	3	2	1

## AVERAGE RATING

**Evaluator note:** To obtain an average rating for the Profile of Training Mastery, total the points in Product Evaluation and divide by the total number of criteria. Circle the rating on the Key.

## KEY

- 4 Skilled** — Can perform job with no additional training
- 3 Moderately Skilled** — Has performed job during training program; limited additional training may be required
- 2 Limited Skill** — Has performed job during training program; additional training is required to develop skill
- 1 Unskilled** — Is familiar with process, but is unable to perform job



## EVALUATOR'S COMMENTS

---

---

---





# **BEAM FORMS**

## **CARPENTRY SERIES**



Student Name: \_\_\_\_\_ Score: \_\_\_\_\_

## CONSTRUCT AND STRIP A SPANDREL BEAM FORM.

### BASIC SKILLS

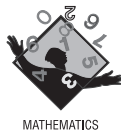

### INTRODUCTION

A spandrel beam shapes the perimeter of a structure and supports a floor and/or roof. This exercise outlines the construction of the spandrel beam form only. The construction steps to integrate the roof or slab forming are not completed, but a description of that process is provided.

### EQUIPMENT AND SUPPLIES

- 1 x 4s for bottom plate, braces, and cleats
- 2 x 2s or larger for sills
- 2 x 4s for studs, upper plates, kickers, and walers
- 4 x 4s or 4 x 6s for stringers
- 4 x 4s or larger for shores
- 6d and 8d box nails
- 8d and 16d duplex nails
- 30" hand level
- Builder's level and rod
- Chalk line
- Circular saw and extension cord

### Words You Should Know

#### Nail point tie

form tie with one end bent 90 degrees and a pointed end

#### Waler

horizontal brace attached to the form

- Claw hammer
- Electric drill and bits
- Form release agent
- Form ties
- Framing square
- Handsaw
- Nail point ties
- Personal protective equipment
- Plumb bob
- Plywood sheathing
- Steel tape
- String line

## PROCEDURE

Yes No

1. Put on personal protective equipment.

2. Determine the beam size.

**NOTE ►** This information will be found in the building/ structural plans and beam schedule. For this exercise, the beam will be 12" wide, 48' high, and 10' 8" long.

3. Fabricate the outside beam side.

A. Cut the plywood to the proper width.

B. Cut the studs and plates to the proper length.

**NOTE ►** Deduct thickness of the top and bottom plates from beam side height to get stud length.

C. Lay out stud spacing on the top and bottom plates. See Figure 179.

D. Nail the studs to the top and bottom plates to create the frame for the two sides of the beam. See Figures 180 and 181.

FIGURE 179

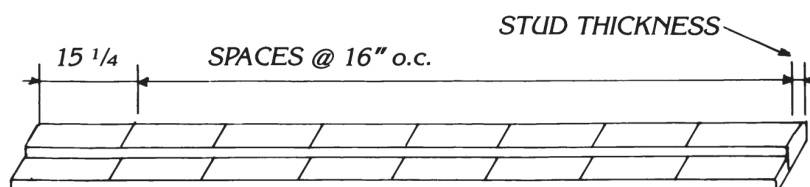
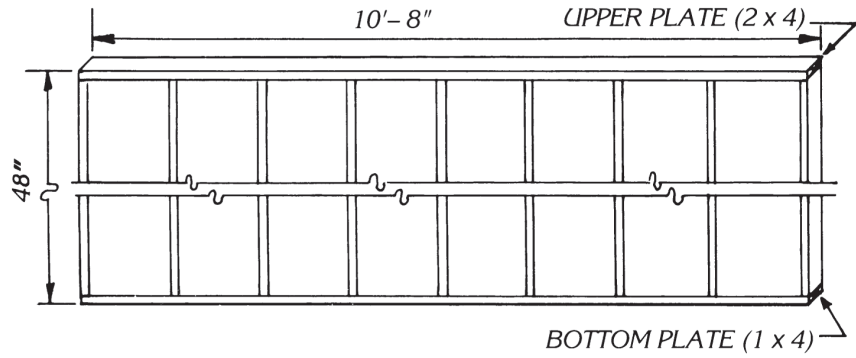

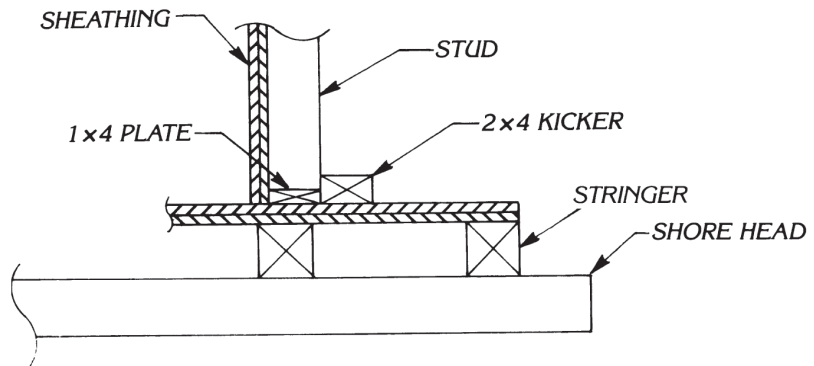

FIGURE 180



**NOTE** ▶ A 2 x 4 should be used for the top plate. A 1 x 4 plate is used on the bottom leaving the studs (2 x 4s) to bear against the kicker as shown in Figure 181.

FIGURE 181



Yes No

E. Cut the sheathing and nail it to the stud frame.

**NOTE** ▶ Sheathing should be flush with all four edges of the stud frame.

4. Lay out and drill the form tie holes.

**NOTE** ▶ Follow the manufacturer's recommendations or specifications for waler and tie spacing.

**NOTE** ▶ The top row of the ties should be the height of the inside form plus slab thickness as shown in Figure 182.

FIGURE 182

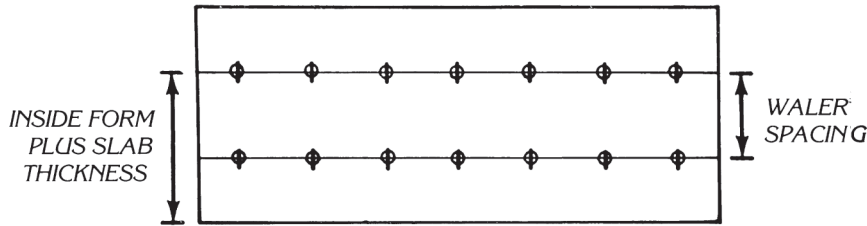

Yes No

**NOTE** ▶ When more than one form side is constructed, use the first beam side drilled for a pattern.

5. Fabricate the inside beam side form.

**NOTE** ▶ Follow the same steps in construction of the outside beam side as was done for the inside beam. Use 36" as the form side height.

6. Build the "T" shores.

- A. Cut the 4 x 4s to length. For this exercise, the overall length of the shores should be 8'. See Figure 185.

**NOTE** ▶ Shore pieces must be cut to have a minimum of a 2' lap.

- B. Lay the shore heads at the end of the shores and at a right angle to the shore. See Figure 183.

**NOTE** ▶ The shore heads should be off center on the shore.

FIGURE 183

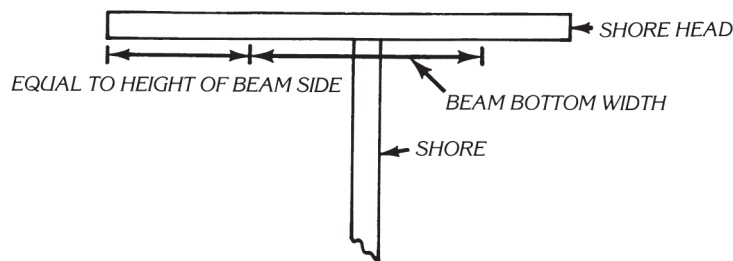

- C. Square the shore head on the shore, Nail a scab across the joint, using a 1 x 4 scab and 16d duplex nails. See Figure 184.

**NOTE** ▶ For the perimeter beams the shore head should be offset to compensate for the walkway and handrail.



FIGURE 184

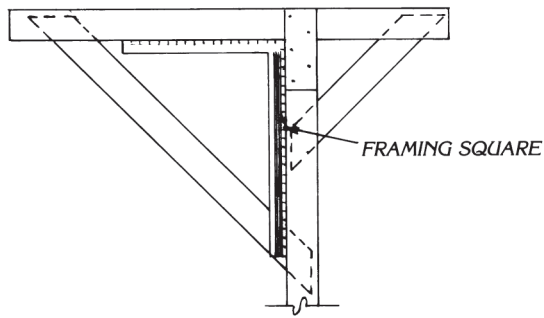

Yes No

D. Install the braces as shown by the dotted lines in Figure 184.

**NOTE** ▶ Check the relationship of the shore head and shore with the framing square.

E. Join the two pieces of the shore with the patented clamps. See Figure 185.

F. Check for the approximate shore length and tighten clamps.

7. Erect the shores and beam form.

A. Lay the mud sills on the center line of the beam. See Figure 186.

B. Nail the stringer (4 x 4s or 4 x 6s) to the two shore heads. The first stringer should be located directly over the shore. See the shaded stringer in Figure 187.

**NOTE** ▶ The shore at the beam end should be held back approximately 1' from the end of the stringer. The other shore should have the stringer end centered on the shore head.

FIGURE 185

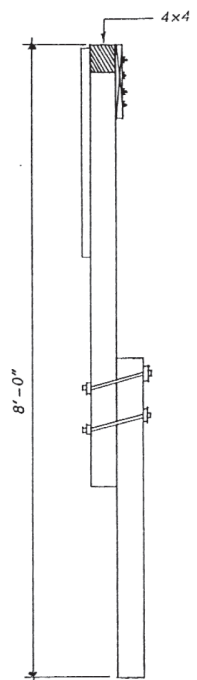



FIGURE 186

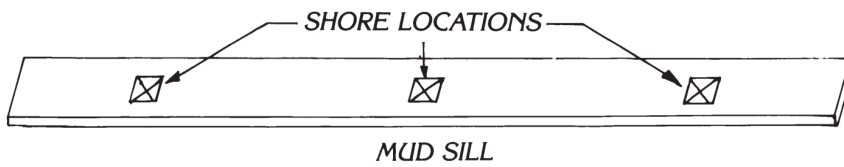
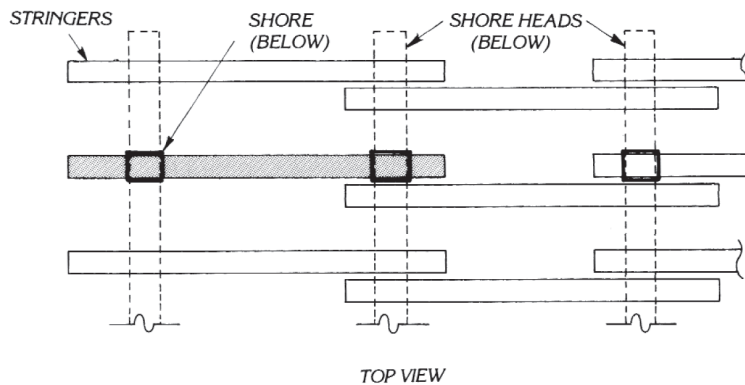

FIGURE 187



Yes No

C. Stand the assembled unit upright on the mud sills and brace the plumb in both directions.

D. Proceed with steps B and C until the entire length of the beam is shored.

E. Install the remaining stringers. See Figure 187.

**NOTE ►** Side stringers should be installed at the beam edges and in position to receive nails through the kicker. Stringers do not have to be cut as they can be lapped on the shore head.

F. Install the supplemental shore head supports. See Figure 188.

**NOTE ►** Supplemental shore head supports are necessary where load is off center of the shore, where the safety rail is needed, and/or on the second floor and above.



FIGURE 188

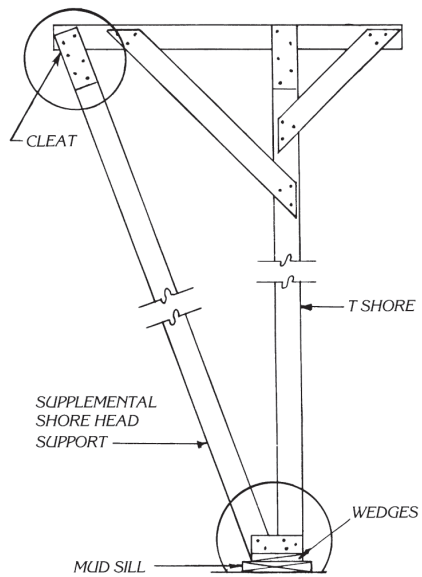

Yes No

G. Nail the plywood decking to the stringers the entire length of the beam.

**NOTE** ▶ This decking should be wide enough to provide a walkway and safety rails for the workers.

H. Install the safety rail. See Figure 189.

FIGURE 189

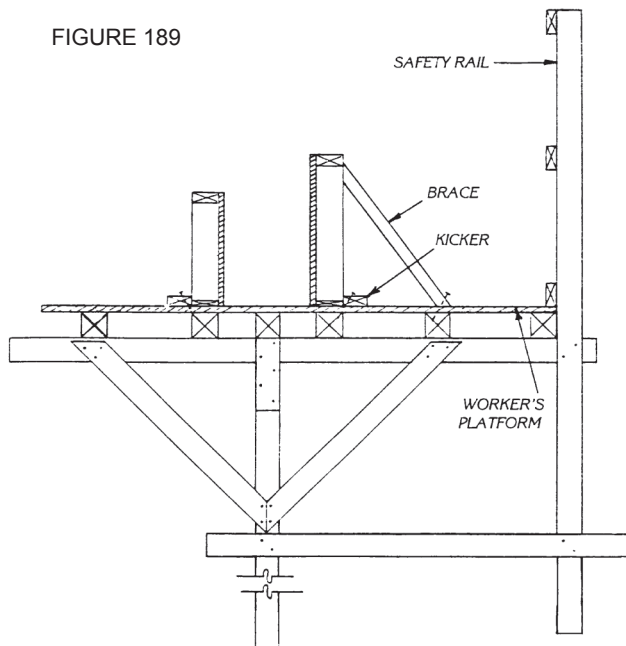

Yes No

- I. Level the beam bottom with a builder's level.

**CAUTION:** Ask your instructor to evaluate your construction before attempting to stand on the decking.

- J. Snap the chalk lines on the plywood, locating both sides of the beam. In this plan, the beam is to be 12" wide and is centered above the shore.

- K. Stand the beam sides on the plywood and nail through the plate to the stringer.

**NOTE** ▶ If the stringers were lapped as shown in Figure 188, short stringers which cross a least two shore heads might have to be added to facilitate the nailing of the form or kicker.

- L. Brace to approximate the line by plumbing the beam side with a hand level.

**NOTE** ▶ If the spreader ties are used, be sure to install them after the first beam side is set.

8. Install the kickers.

**NOTE** ▶ Kickers may be installed prior to the beam side installation if it is more convenient to do so.

9. Install the walers for the lower row of ties.

10. Secure all form tie heads.

11. Install and secure the top row of nail point ties and align the beam side. See Figure 190.

**NOTE** ▶ This row of ties is installed after the deck is in place on top of the inner beam side. Since there is not a deck, drive the nail point tie into the top of the inside beam side. Use the string line to align the top of the beam side.

FIGURE 190

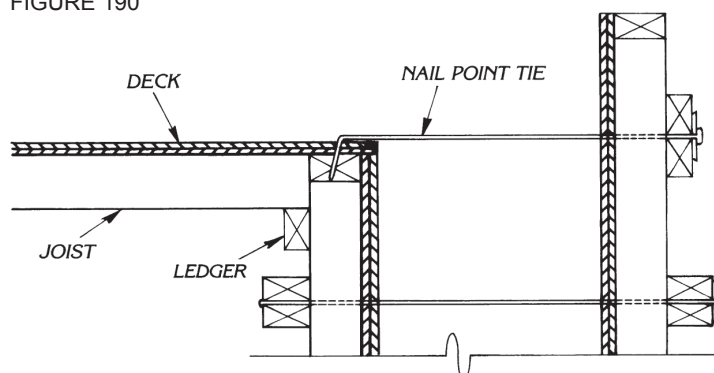



**NOTE ▶** This exercise was designed as an instruction tool and detailed the construction of the spandrel beam only. On the job, the spandrel form would be built as an integrated form with that of the interior beam or slab as shown in Figure 191.

**NOTE ▶** J-hooks and she bolts can be used in place of the nail point tie.

FIGURE 191

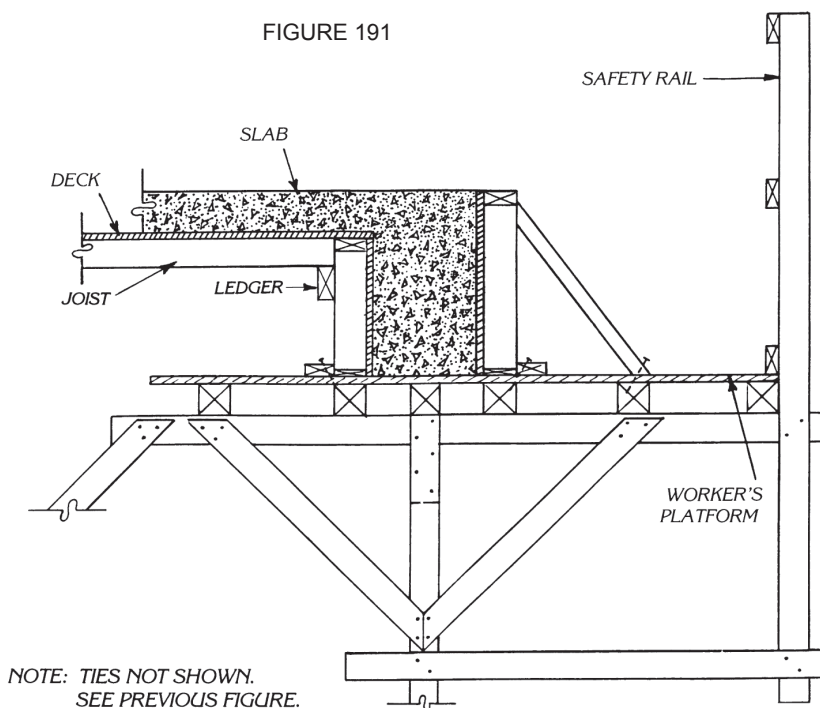

- | Yes                      | No                       |   |
|--------------------------|--------------------------|---|
| <input type="checkbox"/> | <input type="checkbox"/> | 12. Ask your instructor to evaluate your work.  |
| <input type="checkbox"/> | <input type="checkbox"/> | 13. Strip the form in the reverse order of its construction. Ask your instructor if form oil will need to be applied. |
| <input type="checkbox"/> | <input type="checkbox"/> | 14. Clean up area and put away equipment and supplies.  |

## PRODUCT EVALUATION

### SKILL TEST RECORD

**Evaluator note:** Rate the student on the following criteria by circling the appropriate numbers. Each criterion must receive a rating of “3” or higher to demonstrate student mastery. (See Key below.) A student who is unable to demonstrate mastery should review the material and submit another product for evaluation.

Criteria:

Safety equipment used properly	4	3	2	1
Beam is correct dimensions ( $\pm \frac{1}{4}$ "	4	3	2	1
Tie holes in proper location ( $\pm \frac{1}{4}$ "	4	3	2	1
Shore head positioned properly	4	3	2	1
Beam bottom is level ( $\pm \frac{1}{4}$ "	4	3	2	1
Beam sides are plumb and straight	4	3	2	1
Braced properly	4	3	2	1
Joints tight	4	3	2	1

## AVERAGE RATING

**Evaluator note:** To obtain an average rating for the Profile of Training Mastery, total the points in Product Evaluation and divide by the total number of criteria. Circle the rating on the Key.

## KEY

- 4 Skilled** — Can perform job with no additional training
- 3 Moderately Skilled** — Has performed job during training program; limited additional training may be required
- 2 Limited Skill** — Has performed job during training program; additional training is required to develop skill
- 1 Unskilled** — Is familiar with process, but is unable to perform job

## EVALUATOR'S COMMENTS

---

---

---

Student Name: \_\_\_\_\_ Score: \_\_\_\_\_

## CONSTRUCT AND STRIP AN INTERIOR BEAM FORM.

### BASIC SKILLS



### Words You Should Know

#### Shore jack

a tool used to lift some patented shores

### INTRODUCTION

Interior beams are used as the interior framework of a structure. They also provide support for the floors and/or roofs.

### EQUIPMENT AND SUPPLIES

- 2 x 10s or larger for sills
- 2 x 4s for kickers, plates, studs, and cleats
- 3/4" plywood for beam bottom
- 6d and 8d box nails
- 8d and 16d duplex nails
- 30' hand level
- Builder's level
- Circular saw and extension cord
- Claw hammer
- Coupling pins
- Handsaw
- Patented shores
- Personal protective equipment
- Plywood sheathing
- Shore jack
- Steel tape
- String line

## PROCEDURE

Yes No

1. Put on personal protective equipment.
2. Determine the beam size.  
**NOTE** ▶ This information will be found in the building/ structural plans and beam schedule. For this exercise, the interior beam is specified to be 12" wide, 36" high, and 12' long.
3. Cut the plywood to the required width for the beam sides. See Figure 192.  
**NOTE** ▶ Your instructor will advise you of the plywood thickness needed for the deck. In this example, the deck is suggested to be  $\frac{3}{4}$ " plywood. The purlin shown in Figure 192 is 10".
4. With the overall beam size given above, subtract the deck thickness and add the beam bottom thickness to calculate the height of the beam sides.
5. Using Figure 192 and the video "Constructing an Interior Beam Form," build the beam sides.
6. Determine the size and cut plywood for the beam bottom.  
**NOTE** ▶ The width of the beam bottom should be cut to include the width of the beam, the beam sides (plywood and stud thickness), and the kicker width.

FIGURE 192

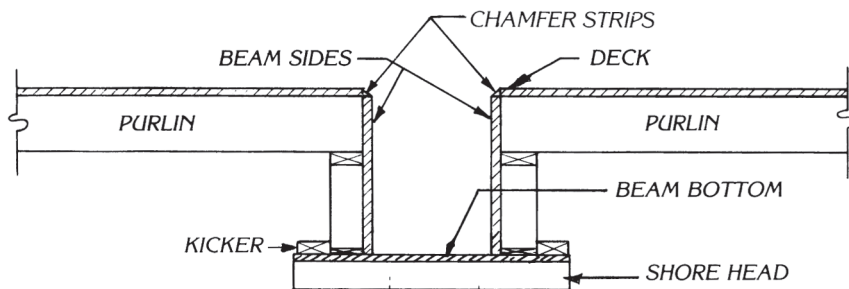



Yes No

7. Erect the scaffolds. See Figure 193.

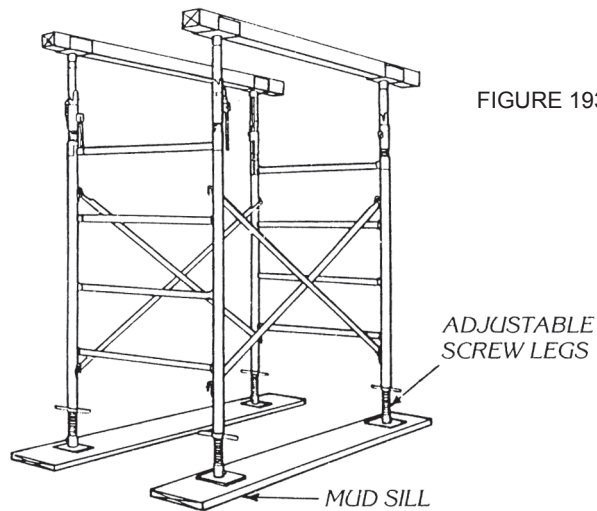

FIGURE 193

A. Lay the mud sills on the deck at the beam centerline.

B. Set the adjustable screw legs in the approximate final locations.

C. Insert the screw legs to the scaffold frame and attach the side braces.

**NOTE** ▶ The screw legs must have base plates.

D. Attach the second frame by raising the brace until it aligns with the stud on the frame.

**NOTE** ▶ If wing nuts are used to attach the braces, catch only enough of the threads to hold the nut on as they will have to be removed to attach the next brace.

E. Attach the braces to the frame's last set.

F. Repeat steps B through E to continue the shoring placement.

G. Place the coupling pins on top of the frame's legs.

**NOTE** ▶ Some patented scaffolds have a small bottom end which slips inside the lower frame. In this case coupling pins will not be needed.



Yes No

- |                          |                          |   |
|--------------------------|--------------------------|---|
| <input type="checkbox"/> | <input type="checkbox"/> | H. Place the scaffold planks on the top of the frames.  |
| <input type="checkbox"/> | <input type="checkbox"/> | I. Set the frame for the second row on the pins.  |
| <input type="checkbox"/> | <input type="checkbox"/> | J. Set the second frame and secure the braces.  |
| <input type="checkbox"/> | <input type="checkbox"/> | K. Attach the braces.   |
| <input type="checkbox"/> | <input type="checkbox"/> | L. Repeat steps G through K to continue shoring placement.  |
| <input type="checkbox"/> | <input type="checkbox"/> | M. Install the U-head screw jacks on all of the frame posts to the approximate level.   |
| <input type="checkbox"/> | <input type="checkbox"/> | 8. Install the stringers by laying stringers in the U-head.<br><b>NOTE</b> ► If the stringers are not as wide as the U-head, block both sides so that the stringer is centered.   |
| <input type="checkbox"/> | <input type="checkbox"/> | 9. Nail the stringers to the predrilled U-head, using the duplex nails.<br><b>NOTE</b> ► Side stringers should be installed at the beam edges and in the position to receive nails through the kicker. Stringers do not have to be cut as they can be lapped on the shore head. |
|                          |                          | 10. Install the beam bottom and sides.  |
| <input type="checkbox"/> | <input type="checkbox"/> | A. Level the beam bottom with the builder's level.  |
| <input type="checkbox"/> | <input type="checkbox"/> | B. Nail the beam sides to the beam bottom.  |
| <input type="checkbox"/> | <input type="checkbox"/> | C. Nail the continuous kicker to the shore heads using two 16d nails per shore head; nail them tightly against the beam side using draw nails if necessary.   |
| <input type="checkbox"/> | <input type="checkbox"/> | 11. Ask your instructor to evaluate your work.  |
| <input type="checkbox"/> | <input type="checkbox"/> | 12. Strip the form in the reverse order.  |
| <input type="checkbox"/> | <input type="checkbox"/> | 13. Clean up area and put away equipment and supplies.  |



## PRODUCT EVALUATION

### SKILL TEST RECORD

**Evaluator note:** Rate the student on the following criteria by circling the appropriate numbers. Each criterion must receive a rating of “3” or higher to demonstrate student mastery. (See Key below.) A student who is unable to demonstrate mastery should review the material and submit another product for evaluation.

Criteria:

Safety equipment used properly	4	3	2	1
Beam size correct	4	3	2	1
Shores installed correctly	4	3	2	1
Beam bottom in level ( $\pm \frac{1}{4}$ "	4	3	2	1
Joints tight	4	3	2	1
Braced properly	4	3	2	1
Beam sides are plumb and straight	4	3	2	1

### AVERAGE RATING

**Evaluator note:** To obtain an average rating for the Profile of Training Mastery, total the points in Product Evaluation and divide by the total number of criteria. Circle the rating on the Key.

### KEY

- 4 Skilled** — Can perform job with no additional training
- 3 Moderately Skilled** — Has performed job during training program; limited additional training may be required
- 2 Limited Skill** — Has performed job during training program; additional training is required to develop skill
- 1 Unskilled** — Is familiar with process, but is unable to perform job

## EVALUATOR'S COMMENTS

---

---

---

Student Name: \_\_\_\_\_ Score: \_\_\_\_\_

## CONSTRUCT AND STRIP A PLATE GIRDER BEAM FORM.

### BASIC SKILLS



### INTRODUCTION

A steel plate girder beam is used as a structural support member where larger support loads are present. The reinforcing center of the plate resembles an "I" beam with a web of steel plate and flanges of angle iron. The plate girder form is frequently used in bridge construction and its design reduces the need for intermediate shoring.

### EQUIPMENT AND SUPPLIES

- 6d and 8d box nails
- 8d and 16d duplex nails
- Air compressor (100 -125 psi)
- Air gun with sockets
- Air hose
- Builder's level and rod
- Building plan
- Circular saw and extension cord
- Claw hammer
- Crane
- Drill bits
- Electric drill, 1/4" or 3/8"
- Patented plate girder form
- Personal protective equipment
- Rope for tag lines
- Steel tape hand level

Due to the cost and safety concerns, your instructor may only review this job sheet with you.

## PROCEDURE

Yes No

1. Put on personal protective equipment.
2. Review the building plan for the dimensions of the plate girder form.
3. Using Figure 194, select the prefabricated metal panels.  
For this exercise, the plate girder form will be used to build a 3' x 3' x 35' long bridge cap.

FIGURE 194

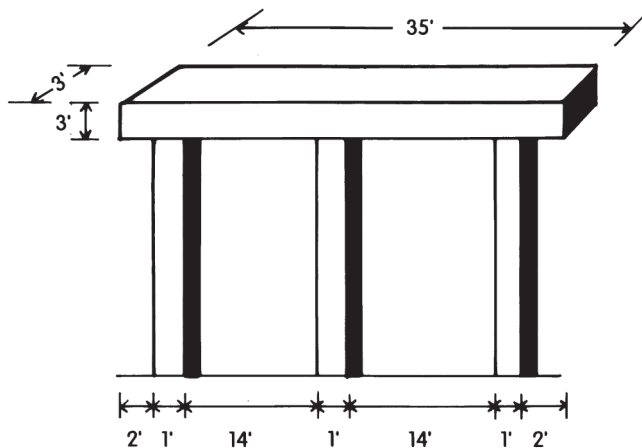

- A. Follow the form manufacturer's instructions to assemble the form panel. Manufacturers offer a variety of panel sizes. Use an air wrench to speed assembly. Follow air wrench safety precautions.  
**NOTE** ► Often the form assembly instructions will indicate that a hinged form panel(s) be used on the bottom of the plate girder form. This facilitates easy stripping/removal of the form.



TABLE 1

**Metal Panel Sizes  
LENGTH**

	1'	2'	4'	8'	12'	20'
<b>WIDTH</b>						
2'	A	A	A	A	A	A
3'	A	A	A	A	A	A
4'	A	A	A	A	A	A
5'	A	A	A	A	A	A
6'	A	A	A	A	A	A
7'	A	A	A	A	A	A
8'	A	A	A	A	A	A
9'	A	A	A	A	X	X
10'	A	A	A	A	X	X
12'	A	A	A	A	X	X

A = Available  
X = Not available

**Yes No**

B. Place the metal spreaders across the tops of the form wall as specified by the form manufacturer or approximately every 4'.

C. Be sure to install the steel taber ties to the form. Use the form manufacturer's spacing specifications.

D. Attach the scaffold brackets to one side of the form. Cut the lumber for the scaffold rails and walkway.

E. Attach the lifting eyes and bolts to the form. These will be used to attach the crane lines. Also place the lifting eyes at each end of the form for easy attachment of the tap lines.

4. Support the bracket installation.

**NOTE ►** Make sure each column has either built-in support brackets or friction collar as in Figure 195. Be sure to adjust the integrated jacks to their mid-level height.

FIGURE 195

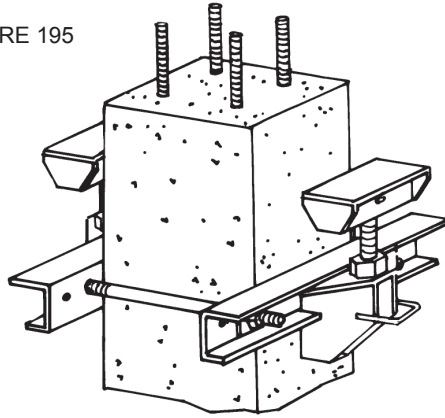

Yes No

5. Double check the form for proper size and be sure the form panels are plumb.

**NOTE** ▶ Form support brackets are rated by weight handling capacity. Be sure to follow the construction plans and manufacturer's specifications.

6. Lift the form onto the columns. See Figure 196.

- A. Attach the sling and crane line to the form.

- B. Using OSHA safety rules, use the crane to lift the form onto the columns.

- C. Use the tag lines to guide the form.

FIGURE 196

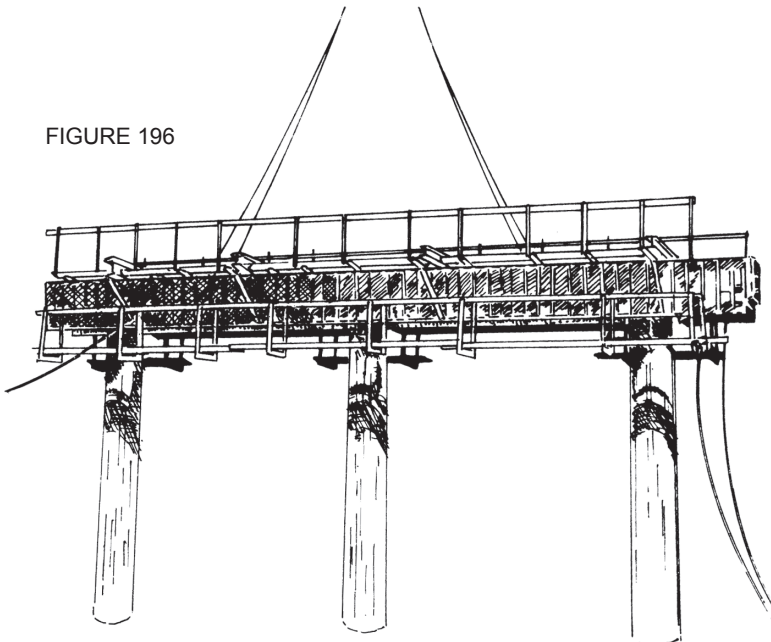



- 7. Using the builder's level and the form jacks to place the form bottom to its proper grade.
- 8. Strip the form in the reverse order.
- 9. Clean up area and put away equipment and supplies.

## PRODUCT EVALUATION

### SKILL TEST RECORD

**Evaluator note:** Rate the student on the following criteria by circling the appropriate numbers. Each criterion must receive a rating of "3" or higher to demonstrate student mastery. (See Key below.) A student who is unable to demonstrate mastery should review the material and submit another product for evaluation.

Criteria:

Safety equipment used properly	4	3	2	1
Beam size correct ( $\pm \frac{1}{4}$ "	4	3	2	1
Hangers and brackets installed properly	4	3	2	1
Joints tight	4	3	2	1
Braced properly	4	3	2	1
Beam bottom is level ( $\pm \frac{1}{4}$ "	4	3	2	1
Form ties in proper location	4	3	2	1
Beam sides are plumb and straight	4	3	2	1

### AVERAGE RATING

**Evaluator note:** To obtain an average rating for the Profile of Training Mastery, total the points in Product Evaluation and divide by the total number of criteria. Circle the rating on the Key.



## KEY

- 4 **Skilled** — Can perform job with no additional training
- 3 **Moderately Skilled** — Has performed job during training program; limited additional training may be required
- 2 **Limited Skill** — Has performed job during training program; additional training is required to develop skill
- 1 **Unskilled** — Is familiar with process, but is unable to perform job

## EVALUATOR'S COMMENTS

---

---

---

# **ABOVE-GRADE SLAB SYSTEMS**

**CARPENTRY SERIES**



ABOVE-GRADE SLAB SYSTEMS  
CARPENTRY SERIES  
**JOB SHEET**

1

Student Name: \_\_\_\_\_ Score: \_\_\_\_\_

**CONSTRUCT AND STRIP FORMS FOR A ONE-WAY JOIST SYSTEM.**

**BASIC SKILLS**



**Words You Should Know**

**Horizontal-adjustable joists**

adjustable beam, truss, or beam and truss combination which supports form work over clear spans and eliminates intermediate vertical supports

**INTRODUCTION**

A one-way joist system provides a way in which a slab is supported by parallel concrete joists. It is formed in a row of joists going in one direction.

**EQUIPMENT AND SUPPLIES**

- 12 x 4 or 2 x 6 lumber to serve as a nailer
- 2 x 8s or larger for mud sills
- 4 x 4s for stringers
- 16d duplex and 6d common nails
- Adjustable shores
- Builder's level
- Chalk line
- Circular saw and extension cord
- Claw hammer
- Coupling pins
- Form release agent
- Handsaw
- Long forms
- Patented shores

- Personal protective equipment
- Plywood deck
- Scaffold
- Square
- Steel tape
- Thirty-inch hand level
- U-head screw jacks
- Wing nuts

## PROCEDURE

Yes No

1. Put on personal protective equipment.
2. Erect the scaffolds and shores.

- A. Lay the mud sill for the scaffold on the deck. See Figure 197.

**NOTE ►** Sill locations should be one-half the frame width on each side of the column center line.

FIGURE 197

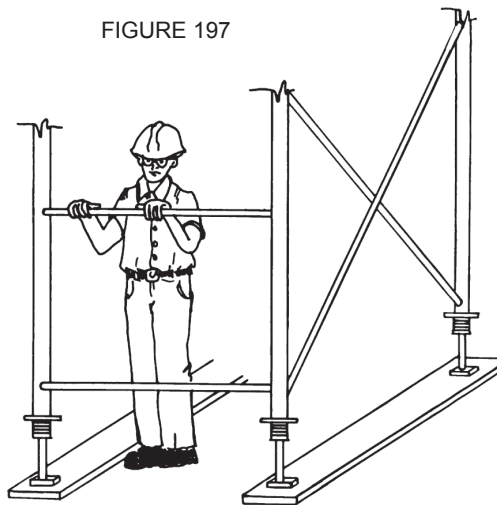

- B. Set the adjustable screw legs or scaffold feet in the approximate final locations (1' from column face).
- C. Insert the screw legs to the scaffold frame and attach to the scaffold side braces to hold the ends erect.
- NOTE ►** Screw legs must have base plates.
- D. Install the U-head screw jacks on all frame post to approximate level. See Figure 198.





Yes No

FIGURE 198

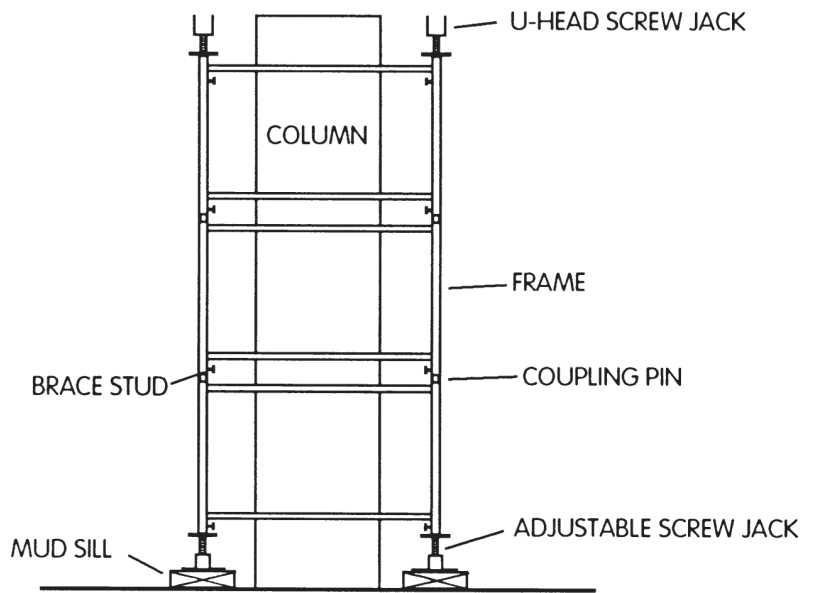

E. Repeat steps B through D to continue scaffold placement.

3. Install stringers.



A. Lay the stringers in the center of the U-Head.

**NOTE** ▶ If the stringers are not as wide as the U-head, block both sides so that the stringer is centered. See Figure 199.

FIGURE 199

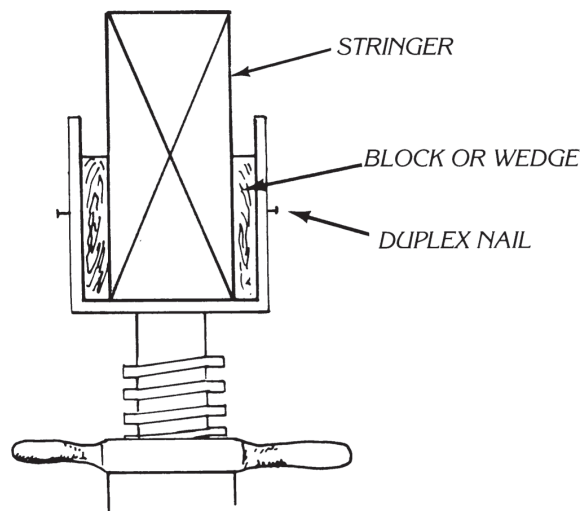

Yes No

B. Clamp or nail the stringers to the U-head.

C. Check the elevation of the stringers so that the finished deck will be at the approximate elevation called for in the plans.

D. Lay out the lines for the horizontal shore positions on the outer stringers and use a chalk line to mark the inner stringers.

4. Install the horizontal adjustable shores.

A. Make a jig for adjusting the shores. See Figure 200.

**NOTE** ▶ A light template with the blocks nailed on each end may also be used to adjust the shores.

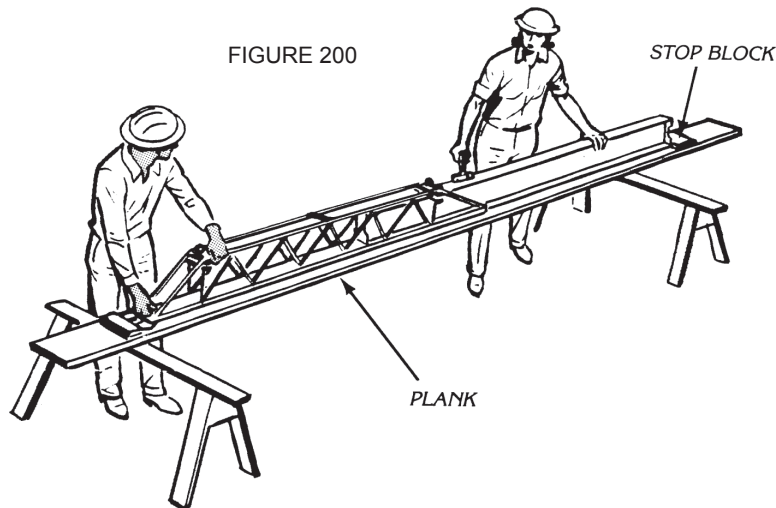

B. Adjust the horizontal adjustable shores to proper length and lock tightly.

C. Place a nail in the hole at each end of the shore to keep it from moving side to side.

D. Lay out lines on the horizontal shores for the soffit boards on 2' centers.

E. Place the soffit boards on the top edge of the horizontal adjustable shores and check them for proper alignment.





Yes No

F. Lay decking over the soffit boards using the minimum number of nails needed to keep the decking in place.

**NOTE** ▶ Be sure to leave an opening in the decking for the column or column form.

G. According to OSHA standards install safety rails on outside walkway and place an awareness rope at the leading edge of the deck.

**NOTE** ▶ Wear safety belt when appropriate.

5. Lay out lines on the decking for the long forms according to your plans.

A. Lay out the beam centers.

B. From the beam centers, determine the distance to the pan flange.

C. Snap the chalk lines on each side of the beam where the pan flanges will be placed.

D. Lay out the joists center lines using the plans.

E. Determine the distance from the joist center line to the pan flanges.

F. Snap a chalk line for the pan flange edges.

6. Install the pan form. See Figure 201.

**NOTE** ▶ Be sure to use form release agent on the pan form before placing it on the decking.

**CAUTION:** Form release agent may be toxic. Be sure to follow the manufacturer's safety instructions.

FIGURE 201

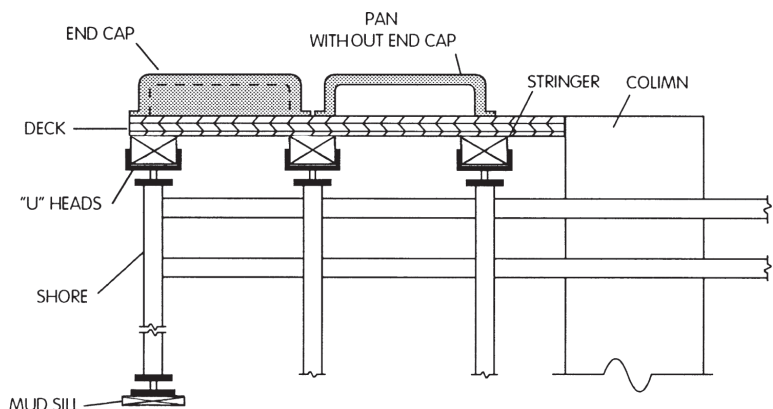



Yes No

A. Nail the end caps for the long forms in place on the decking.

B. Lay the long forms on the decking in accordance with the lines you have drawn.

**NOTE** ► Be sure the flanges of the forms are butted together.

C. Nail the long forms to the decking according to manufacturer's instructions.

D. Put the edge form in place according to your plans.

E. Nail a kicker in place on the outside of the edge form and add braces to the outside of the edge form to hold it plumb.

F. Check the plumb and alignment of the edge form and adjust as necessary.

**NOTE** ► Apply form release agent to the edge form before any reinforcing material is put in place.

**CAUTION:** Form release agent may be toxic. Be sure to follow the manufacturer's safety instructions.

7. Check the elevation of the deck. See Figure 202.

A. Set up a transit or laser level on the floor below the deck.

B. Establish the height of instrument (HI).

C. Make a story pole to correspond with the elevation at the bottom of the deck.

D. Adjust the U-heads on the scaffolds to obtain the correct elevation.

FIGURE 202

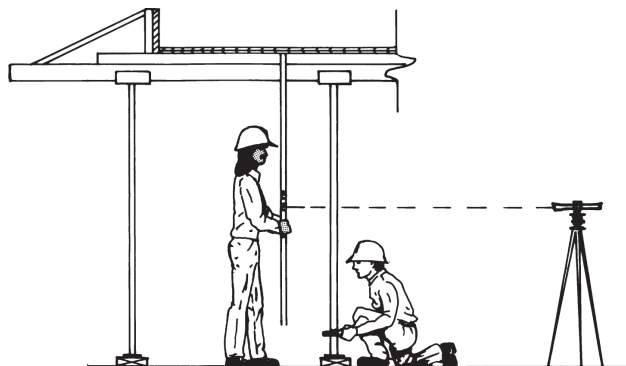



Yes No

8. Ask your instructor to check your work for accuracy and soundness.

9. Strip the form in reverse order of its construction.

10. Clean the domes.

A. Scrape off any concrete on the forms.

B. Scrub the domes with burlap saturated with form release agent.

C. Make a neat pile of the forms.

**NOTE** ► Do not throw domes; this will damage them. Stack the pan forms according to the manufacturer's recommendations.

11. Clean up area and put away equipment and supplies.

## PRODUCT EVALUATION

### SKILL TEST RECORD

**Evaluator note:** Rate the student on the following criteria by circling the appropriate numbers. Each criterion must receive a rating of "3" or higher to demonstrate student mastery. (See Key below.) A student who is unable to demonstrate mastery should review the material and submit another product for evaluation.

Criteria:

Safety equipment used properly	4	3	2	1
Scaffold shoring centered	4	3	2	1
Scaffold planks placed properly for safe use	4	3	2	1
Decking installed across complete slab area for safety	4	3	2	1
Proper elevation	4	3	2	1
Form plumb	4	3	2	1
Joints tight	4	3	2	1

End cap securely fastened	4	3	2	1
Long forms installed according to manufacturer's instructions	4	3	2	1
Long forms properly cleaned and stored	4	3	2	1

## AVERAGE RATING

**Evaluator note:** To obtain an average rating for the Profile of Training Mastery, total the points in Product Evaluation and divide by the total number of criteria. Circle the rating on the Key.

## KEY

- 4 **Skilled** — Can perform job with no additional training
- 3 **Moderately Skilled** — Has performed job during training program; limited additional training may be required
- 2 **Limited Skill** — Has performed job during training program; additional training is required to develop skill
- 1 **Unskilled** — Is familiar with process, but is unable to perform job

## EVALUATOR'S COMMENTS

---



---



---



ABOVE-GRADE SLAB SYSTEMS  
CARPENTRY SERIES  
**JOB SHEET**

**2**

Student Name: \_\_\_\_\_ Score: \_\_\_\_\_

**CONSTRUCT AND STRIP FORMS FOR A TWO-WAY JOIST SYSTEM.**

**BASIC SKILLS**



**Words You Should Know**

**Story pole**

a rod or board that is graduated and used for repetitious measurements

**INTRODUCTION**

A two-way joist system uses reinforced concrete to create a slab that is supported by perpendicular concrete joists and allows for relatively thin slabs to span large areas. It is formed by joists placed at right angles creating a waffle style slab.

**EQUIPMENT AND SUPPLIES**

- 16d duplex and 6d common nails
- 2 x 4 or 2 x 6 lumber to serve as a nailer
- 2 x 8s or larger for mud sills
- 4 x 4s for purlin/joists
- 4 x 6s for stringers
- Adjustable shores
- Air compressor, 100 to 125 psi
- Air gun (To be furnished by the dome manufacturer)
- Air hose
- Builder's level
- Burlap
- Chalk line
- Circular saw and extension cord
- Claw hammer
- Coupling pins

- Dome forms
- Form release agent
- Handsaw
- Horizontal shores
- Nails for domes
- Personal protective equipment
- Plywood deck
- Sawhorses
- Scaffold
- Screw jacks
- Steel tape
- String line
- Thirty-inch hand level
- U-head screw jacks
- Wrecking bar

## PROCEDURE

Yes No

1. Put on personal protective equipment.
2. Erect the scaffolds and shores.

- A. Lay the mud sill for the scaffold on the deck.  
See Figure 203.

**NOTE** ► Sill locations should be one-half the frame width on each side of the column center line.

FIGURE 203

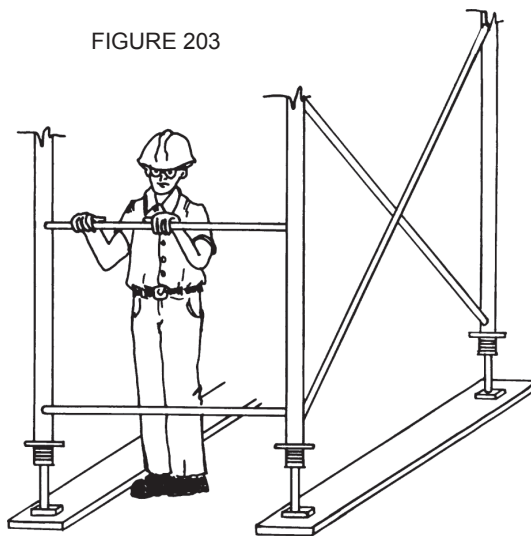

- B. Set the adjustable screw legs or scaffold feet in the approximate final locations (1' from column face).



Yes No

C. Insert the screw legs to the scaffold frame and attach to the scaffold side braces to hold the ends erect

**NOTE** ▶ Screw legs must have base plates.

D. Install the U-head screw jacks on all frame post to approximate level. See Figure 204.

FIGURE 204

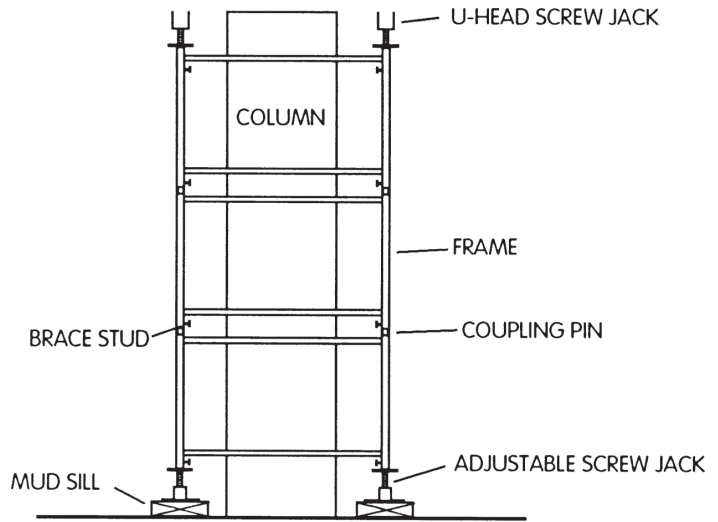

E. Repeat steps B through E to continue scaffold placement.

3. Install stringers.

A. Lay the stringers in the center of the U-Head.

**NOTE** ▶ If the stringers are not as wide as the U-head, block both sides so that the stringer is centered. See Figure 205.

FIGURE 205

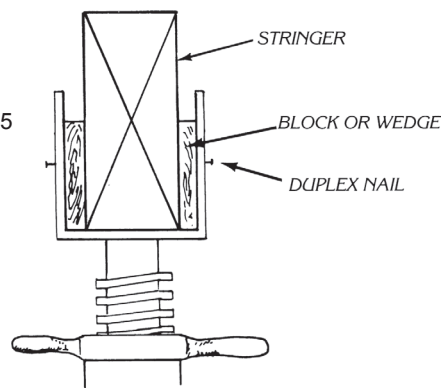

Yes No

B. Clamp or nail the stringers to the U-head.

C. Check the elevation of the stringers so that the finished deck will be at the approximate elevation called for in the plans.

D. Lay out the lines for the horizontal shore positions on the outer stringers and use a chalk line to mark the inner stringers.

4. Install the horizontal adjustable shores.

A. Make a jig for adjusting the shores. See Figure 206.

**NOTE** ▶ A light template with the blocks nailed on each end may also be used to adjust the shores.

FIGURE 206

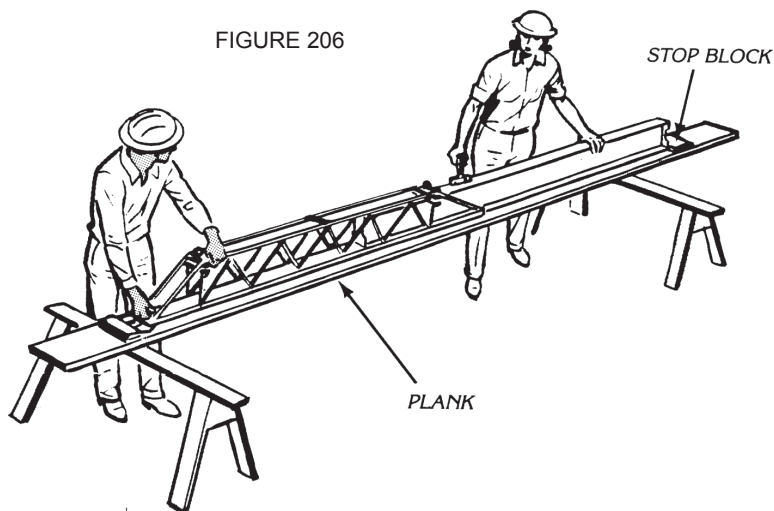

B. Adjust the horizontal adjustable shores to proper length and lock tightly.

C. Place a nail in the hole at each end of the shore to keep it from moving side to side.

D. Lay out lines on the horizontal shores for the soffit boards on 2' centers.

E. Place the soffit boards on the top edge of the horizontal adjustable shores and check them for proper alignment.





Yes No

F. Lay decking over the soffit boards using the minimum number of nails needed to keep the decking in place.

**NOTE** ► Be sure to leave an opening in the decking for the column or column form.

G. According to OSHA standards install safety rails on outside walkway and place an awareness rope at the leading edge of the deck.

**NOTE** ► Wear safety belt when appropriate.

5. Put the edge form in place according to your plans.

6. Nail a kicker in place on the outside of the edge form and add braces to the outside of the edge form to hold it plumb.

7. Check the plumb and alignment of the edge form and adjust as necessary.

8. Layout lines on the decking.

A. Snap the chalk line on the deck at the sides of the beam.

B. Measure from the column center line to edge of the first dome determined by the shop drawings and place pencil mark at this point. Snap a line and continue to lay out for the edge of the domes.

9. Install the domes.

A. Set the first dome, aligning the dome flange with the chalk line on one edge, and placing the pencil mark at the adjoining edge. See Figure 207.

**NOTE** ► Check manufacturer's specifications for nailing and header instructions.



Yes No

FIGURE 207

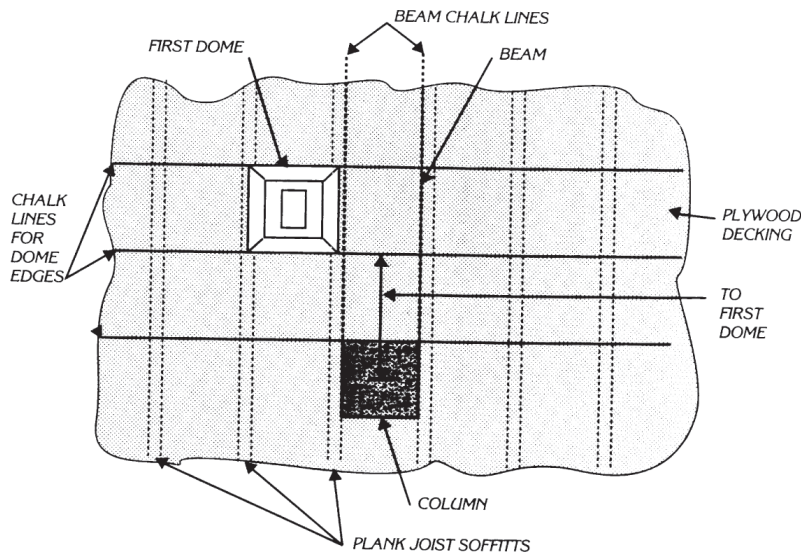
B. Continue to install dome forms being sure the flanges of the domes are butted together.

C. Nail the forms to the decking according to the manufacturer's instructions.

**NOTE** ▶ Form release agent should be applied to the dome forms before any reinforcing material is put in place.

**CAUTION:** Form release agent may be toxic. Be sure to follow the manufacturer's safety instructions.

10. Check the elevation of the deck. See Figure 208.

A. Set up a transit or laser level on the floor below the deck.

B. Establish the height of instrument (HI).

C. Make a story pole to correspond with the elevation at the bottom of the deck.

 

D. Adjust the U-heads on the scaffolds to obtain the correct elevation.



Yes No

FIGURE 208

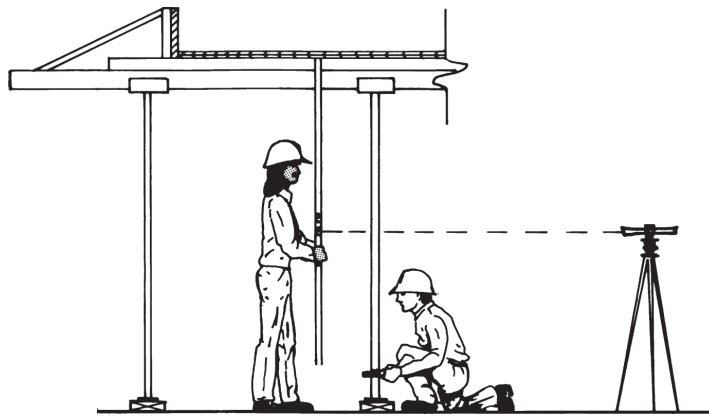

11. Install the bulkhead.

**NOTE** ▶ If the entire floor cannot be poured at one time, a bulkhead must be installed. If the location is not given in the plans or specifications, check with your instructor or supervisor for a permissible location.



A. Place a 2 x 4 under the wire mesh on the end of the pour.



B. Anchor to the pans using the method recommended by the manufacturer.



C. Lay the 2 x 4 on top of the wire mesh slab reinforcement and first 2 x 4.



D. Wedge the upper 2 x 4 to proper elevation and nail to the lower 2 x 4 with the duplex nails.



E. Cut the tapered pieces of the lumber or plywood for the joist area. See Figure 209.

FIGURE 209

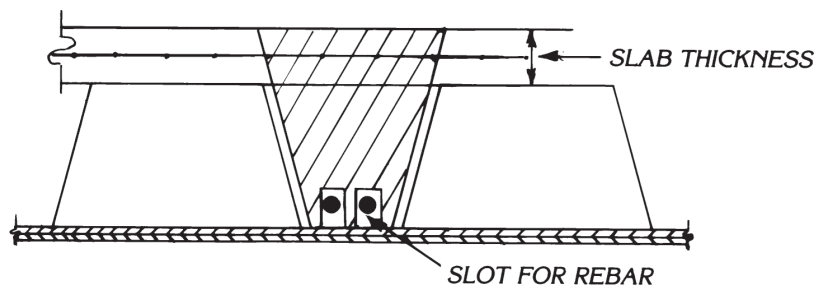

Yes No

- F. Nail the bulkhead pieces to the 2 x 4s.
- G. Brace the bottom of the bulkhead. See Figure 210.

FIGURE 210

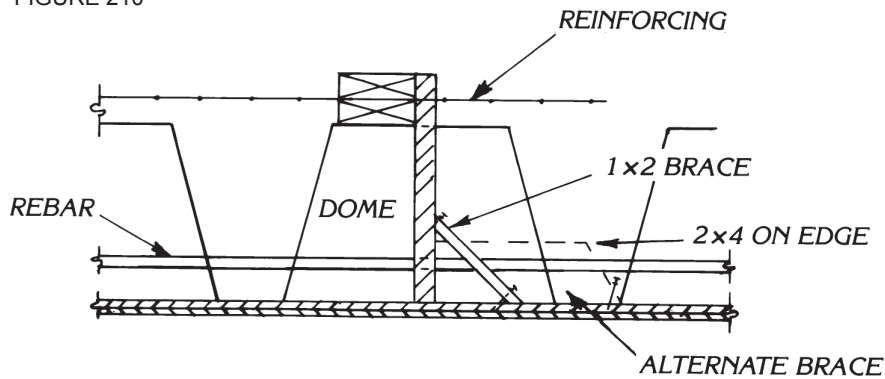

12. Ask your instructor to check your work for accuracy and soundness.
13. Strip the two-way form in reverse order of its constructions.
- CAUTION:** The center of the shore bottoms might be loose. Watch for loose members and remove them immediately. Check with your instructor or supervisor for the reshore spacing if required.

- A. Lower the shore scaffold by loosening the U-heads or the upper or lower screws.
- WARNING:** Lower scaffold only after concrete has reached its designed stripping strength.

- B. Remove the scaffolding.

- C. Pry loose and remove the forming.

- D. Remove the domes.

**NOTE** ► Never pry on the flange of the dome forms. Some Domes have special valves in the top for the insertion of the air gun.

- 1) Blow out the domes with an air gun.





Yes No

- 2) Check for the following problems if the dome does not pop out. Follow the instructions for correcting the problem.

**NOTE ►** Remove excessive concrete when it is still wet to prevent problems removing domes.

- **Problem:** Air is not going through the stripping valve.
- **Solution:** Center punch the stripping plug with a nail or sharp rod and try to blow it out again.
  
- **Problem:** Attachment to the dome top
- **Solution:** Make sure the rivets or pins have been pulled out or that the special attachment fastenings are loose.
  
- **Problem:** Excessive grout seepage under the flange.
- **Solution:** Chip the concrete away with a hammer.
  
- **Problem:** Concrete-encrusted forms
- **Solution:** Chip the concrete away with a hammer.



E. Clean the domes.

- 1) Scrape off any concrete on the forms.
- 2) Scrub the domes with burlap saturated with form release agent.
- 3) Make a neat pile of the forms.

**NOTE ►** Do not throw domes; this will damage them. Stack the pan forms according to the manufacturer's recommendations.



14. Ask your instructor to check your work.



15. Clean up area and put away equipment and supplies.

# PRODUCT EVALUATION

## SKILL TEST RECORD

**Evaluator note:** Rate the student on the following criteria by circling the appropriate numbers. Each criterion must receive a rating of “3” or higher to demonstrate student mastery. (See Key below.) A student who is unable to demonstrate mastery should review the material and submit another product for evaluation.

Criteria:

Safety equipment used properly	4	3	2	1
Scaffold shoring centered	4	3	2	1
Scaffold planks place properly for safe use	4	3	2	1
Decking installed across complete slab area for safety	4	3	2	1
Proper elevation	4	3	2	1
Dome placed properly ( $\frac{1}{4}$ "	4	3	2	1
Joint tight	4	3	2	1
Dome properly cleaned and stored	4	3	2	1





## AVERAGE RATING

**Evaluator note:** To obtain an average rating for the Profile of Training Mastery, total the points in Product Evaluation and divide by the total number of criteria. Circle the rating on the Key.

## KEY

- 4 Skilled** — Can perform job with no additional training
- 3 Moderately Skilled** — Has performed job during training program; limited additional training may be required
- 2 Limited Skill** — Has performed job during training program; additional training is required to develop skill
- 1 Unskilled** — Is familiar with process, but is unable to perform job

## EVALUATOR'S COMMENTS

---

---

---



ABOVE-GRADE SLAB SYSTEMS  
CARPENTRY SERIES  
**JOB SHEET**

**3**

Student Name: \_\_\_\_\_ Score: \_\_\_\_\_

**CONSTRUCT, SET, AND STRIP A FLYING SLAB FORM.**

**BASIC SKILLS**



**INTRODUCTION**

A flying slab form is a large prefabricated sectional form that is used to construct concrete structures such as above-grade slabs. They are often lifted into position using cranes and are designed for reuse at another location.

The cost and safety issues involved with this task may prevent the completion of this job sheet. Your instructor may wish to review these procedures or assign you to a scaled-down model.

**EQUIPMENT AND SUPPLIES**

- Air compressor (100 to 125 psi)
- Air hose
- Air wrench with sockets
- Builder's level
- Hand level
- Personal protective equipment
- Plywood decking
- Pre-fabricated flying truss form
- Screw jacks
- Steel tape
- Truss roller assemblies



## PROCEDURE

Yes No

- |                          |                          |  |
|--------------------------|--------------------------|--|
| <input type="checkbox"/> | <input type="checkbox"/> | 1. Put on personal protective equipment.   |
| <input type="checkbox"/> | <input type="checkbox"/> | 2. Use the manufacturer's instructions to assemble the flying truss form to match building plans. Use an air wrench to speed assembly. See Figure 211. |

**NOTE** ▶ Be sure the height of the form incorporates the plywood decking thickness, the joist beams, the rollers, and the lifting distance of the screw jacks. The screw jacks may be adjusted when the form is placed and ready to be lifted to grade, usually no more than 3" to 6".

FIGURE 211

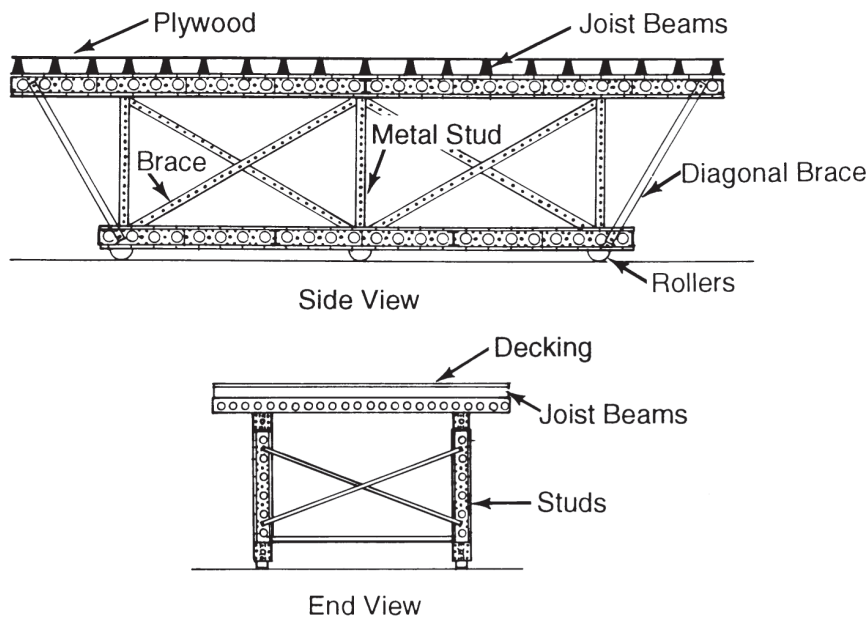

- |                          |                          |   |
|--------------------------|--------------------------|---|
| <input type="checkbox"/> | <input type="checkbox"/> | 3. Using the building plans, add decking material to the form.  |
|                          |                          | <b>NOTE</b> ▶ If pan forms are designated by the plan, they can be attached to the deck now and lifted into position.   |
|                          |                          | <b>NOTE</b> ▶ As the deck is constructed, consider the connection of the slings for the crane lines. Small knock-out panels in the deck will accommodate the lines. |
| <input type="checkbox"/> | <input type="checkbox"/> | 4. Attach the guard rail to the top deck area.  |



- 5. Attach the hand or tag lines to the guide or snub the load as needed.
- 6. Using OSHA crane safety rules, attach the crane sling lines to the flying form.
- 7. With trained personnel in position, guide the flying form into position. See Figure 212.

FIGURE 212

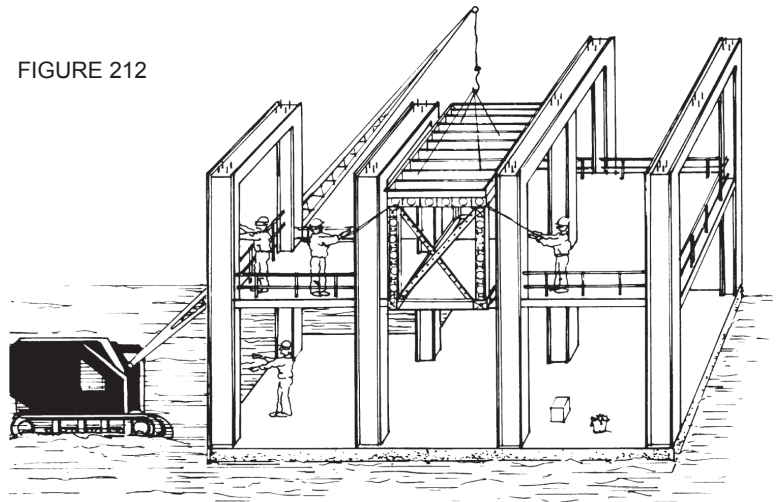

- 8. Once the flying form is in position, remove the crane and tag lines.
- 9. Position the remaining flying forms.
- 10. Using a builder's level, adjust the screw jacks to bring the bottom of the decks up to grade.
- 11. Deck any areas needed and built the slab side walls to plan specifications. Ensure the forms are plumb and level.
- 12. Ensure the rebars are cut to their proper height above the columns.
- 13. Ask your instructor to check your work for accuracy.
- 14. Strip the form by removing the slab side forms and lowering the screw jacks.
- 15. Once all interconnection of the forms are removed, the crane can be removed.
- 16. Clean up area and put away equipment and supplies.

# PRODUCT EVALUATION

## SKILL TEST RECORD

**Evaluator note:** Rate the student on the following criteria by circling the appropriate numbers. Each criterion must receive a rating of “3” or higher to demonstrate student mastery. (See Key below.) A student who is unable to demonstrate mastery should review the material and submit another product for evaluation.

Criteria:

<u>Safety crane rules followed</u>	<u>4</u>	<u>3</u>	<u>2</u>	<u>1</u>
<u>Safety equipment used properly</u>	<u>4</u>	<u>3</u>	<u>2</u>	<u>1</u>
<u>Deck joints tight (<math>\pm\frac{1}{8}</math>" )</u>	<u>4</u>	<u>3</u>	<u>2</u>	<u>1</u>
<u>Truss form proper size</u>	<u>4</u>	<u>3</u>	<u>2</u>	<u>1</u>
<u>Slab form level and plumb (<math>\pm\frac{1}{4}</math>" )</u>	<u>4</u>	<u>3</u>	<u>2</u>	<u>1</u>
<u>Truss form at grade</u>	<u>4</u>	<u>3</u>	<u>2</u>	<u>1</u>

## AVERAGE RATING

**Evaluator note:** To obtain an average rating for the Profile of Training Mastery, total the points in Product Evaluation and divide by the total number of criteria. Circle the rating on the Key.

## KEY

- 4 Skilled** — Can perform job with no additional training
- 3 Moderately Skilled** — Has performed job during training program; limited additional training may be required
- 2 Limited Skill** — Has performed job during training program; additional training is required to develop skill
- 1 Unskilled** — Is familiar with process, but is unable to perform job





## EVALUATOR'S COMMENTS

---

---

---



Student Name: \_\_\_\_\_ Score: \_\_\_\_\_

**SET SCREEDS ON A DECK FOR A FLAT SLAB.**

**BASIC SKILLS**



**INTRODUCTION**

Once a slab form is set, screeds can be used to level or strikeoff freshly poured concrete. Screeds are used as a guide to ensure that the proper concrete depth is maintained.

**EQUIPMENT AND SUPPLIES**

- 18d duplex nails
- Adjustable screed chairs
- Builder's level and rod
- Claw hammer
- Personal protective equipment
- Screed pipe or steel bar (depending on type of chairs used)
- Steel tape
- String line

## PROCEDURE

Yes No

- |                          |                          |  |
|--------------------------|--------------------------|--|
| <input type="checkbox"/> | <input type="checkbox"/> | 1. Put on personal protective equipment.   |
|                          |                          | 2. Establish the screed location.  |
| <input type="checkbox"/> | <input type="checkbox"/> | A. Measure across one end of the forms to determine the width of pour (48' 0").  |
| <input type="checkbox"/> | <input type="checkbox"/> | B. Divide the area into four equal parts (12' 0").   |
| <input type="checkbox"/> | <input type="checkbox"/> | C. Mark the location of each run of screeds on the form at each end of the pour.   |
| <input type="checkbox"/> | <input type="checkbox"/> | 3. Set a nail at each mark on the forms.   |
| <input type="checkbox"/> | <input type="checkbox"/> | 4. Attach a string line in a straight line from a nail on one form to a nail on the opposite form.<br><b>NOTE</b> ▶ This line is used as a guide to set the chairs in a straight line.   |
| <input type="checkbox"/> | <input type="checkbox"/> | 5. Starting at one end, nail the screed chairs to the deck approximately 4' apart.<br><b>NOTE</b> ▶ The distance between the chairs will vary according to the size of the screed pipe or bar. The screed needs to be closer together if using small-diameter pipe or small bar. |
| <input type="checkbox"/> | <input type="checkbox"/> | 6. Install screed bar or pipes set to the proper elevation.<br><b>NOTE</b> ▶ The screed will be moved along as the pour progresses and the screed chairs will need to be removed after the screed has been moved forward. See Figure 213.  |
| <input type="checkbox"/> | <input type="checkbox"/> | 7. Ask your instructor to check your work for accuracy.  |
| <input type="checkbox"/> | <input type="checkbox"/> | 8. Clean up area and put away equipment and supplies.  |





FIGURE 213

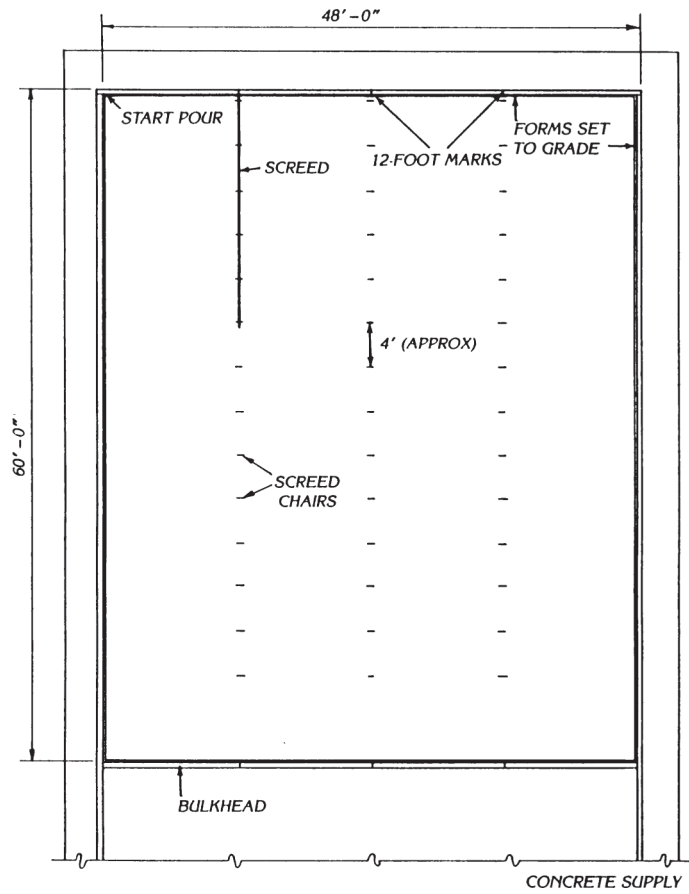

## PRODUCT EVALUATION

### SKILL TEST RECORD

**Evaluator note:** Rate the student on the following criteria by circling the appropriate numbers. Each criterion must receive a rating of “3” or higher to demonstrate student mastery. (See Key below.) A student who is unable to demonstrate mastery should review the material and submit another product for evaluation.

Criteria:

Safety equipment used properly	4	3	2	1
Screeed chairs at proper location (1/4")	4	3	2	1
Screeed bar at proper elevation	4	3	2	1



## AVERAGE RATING

**Evaluator note:** To obtain an average rating for the Profile of Training Mastery, total the points in Product Evaluation and divide by the total number of criteria. Circle the rating on the Key.

## KEY

- 4 **Skilled** — Can perform job with no additional training
- 3 **Moderately Skilled** — Has performed job during training program; limited additional training may be required
- 2 **Limited Skill** — Has performed job during training program; additional training is required to develop skill
- 1 **Unskilled** — Is familiar with process, but is unable to perform job

## EVALUATOR'S COMMENTS

---

---

---



# **BRIDGE DECK FORMS**

**CARPENTRY SERIES**





# BRIDGE DECK FORMS CARPENTRY SERIES JOB SHEET

Student Name: \_\_\_\_\_ Score: \_\_\_\_\_

## CONSTRUCT AND STRIP FORMS FOR A BRIDGE DECK.

### BASIC SKILLS



### INTRODUCTION

During this exercise, you will construct and strip forms for a bridge deck. Your instructor will provide you with the dimensions of the form; however, the recommended lumber sizes are provided within the equipment listing.

### EQUIPMENT AND SUPPLIES

- All thread rod with speed thread  $\frac{1}{2}$ "
- Brace (1 x 4)
- Chalk line
- Circular saw and extension cord
- Combination square
- Duplex nails, 6d and 16d
- Edge form or parapet
- Expansion joint material
- Form bolts,  $\frac{1}{2}$ "
- Hammer
- Handsaw
- Hangers to fit beam size
- Job-built or manufactured brackets
- Joists (2 x 6)
- Level
- Nuts
- Personal protective equipment
- Plastic sleeves for bolts

- Soffit ( $\frac{3}{4}$ " plywood)
- Steel tape
- Stringer or whaler
- Supports ( $\frac{3}{4}$ " plywood decking)
- Utility knife
- Washers, 4" x 4" x  $\frac{1}{4}$ "
- Wrecking bar

## PROCEDURE

Yes No

- 1. Put on personal protective equipment
- 2. Use Figure 214 as the plan to construct a bridge deck.

FIGURE 214

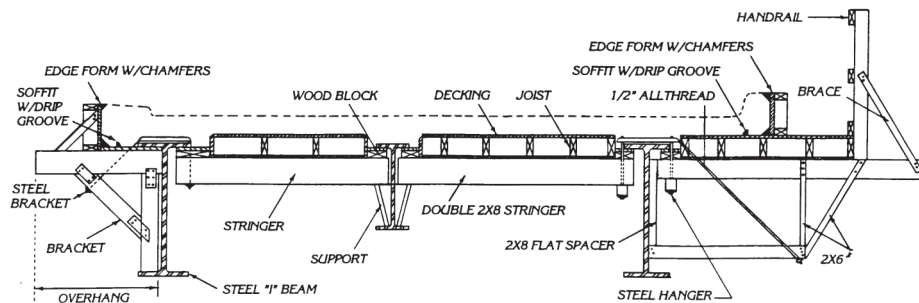

3. Construct the stringer.

- A. Measure and cut the 2x stringer material to the desired length.
- B. Nail these together with  $\frac{3}{4}$ " spacers to form a double 2x whaler.

4. Build the brackets.

- A. Measure and cut 2x square to form the overhang.
- B. Measure and cut 2x square to form the brace between the overhang and the bottom of the "I" beam.

**NOTE** ► Be sure to consider the width of the soffit decking ( $\frac{3}{4}$ ") before cutting.



Yes No

C. Measure and cut the double 2x brace between the overhang and the vertical brace. (This double brace will form a whaler for the steel hanger or all thread.)

D. Use these cut members of material as a pattern to cut the lumber for the other brackets.

E. Form the brackets by using cleats and duplex nails.

5. Build the soffit.

A. Build the soffit ( $\frac{3}{4}$ " plywood) to the desired length and width.

B. Notch the soffit ( $\frac{3}{4}$ " plywood) for the hanger bolts (steel brackets) at the proper spacing.

6. Build the edge form.

A. Measure and cut the  $\frac{3}{4}$ " sheathing to the proper height and length.

B. Construct the edge form for both sides of the bridge deck using the sheathing material and the 2x material.

7. Erect the stringers.

A. Lay out the hanger positions on the bridge beams.

B. Assemble the hangers.

C. Measure and cut 2x material for the "I" beam support for the other end of the stringer.

**NOTE** ► Be sure to consider the width of the wood block before cutting.

D. Secure one end of the stringers on bolts in the hangers with the nuts.

E. Secure the other end of the stringer with the 2x supports.

8. Install the brackets and soffit decking using a steel hanger or all thread.

9. Place the edge form (opposite side of the bridge from the handrail).

A. Nail the edge form to the brackets.

- B. Add 1 x 4 braces and ensure the form is plumb.
  - C. Cut and install drip groove and chamfers.
10. Construct the deck.
- A. Measure and cut the joists.
  - B. Cut the ¾" plywood and nail it at the edge and the ends.  
**NOTE ►** Do NOT overnail because it will make it difficult to strip the form. Be sure to allow space for the soffit form at the beam.
  - C. Bring the deck to grade (use wood blocks or wedges).
11. Lay out and construct the walkway.
- A. Add the handrail.
  - B. Attach the brace.
12. Install the edge form (handrail side of the bridge form).
- A. Use a chalk line to mark the position of the edge form.
  - B. Nail the chamfer to the line.
  - C. Place the edge form to the line to ensure that the form is plumb.
  - D. Nail chamfer to the top grade (top of the edge form).
- 13. Ask your instructor to evaluate your work.
  - 14. Strip the form in the reverse order of its construction.
  - 15. Clean up area and put away equipment and supplies.

## PRODUCT EVALUATION

### SKILL TEST RECORD

**Evaluator note:** Rate the student on the following criteria by circling the appropriate numbers. Each criterion must receive a rating of “3” or higher to demonstrate student mastery. (See Key below.) A student who is unable to demonstrate mastery should review the material and submit another product for evaluation.





Criteria:

Safety equipment used properly	4	3	2	1
Hanger bolts secure	4	3	2	1
Form plumb and at grade	4	3	2	1
Braces secure	4	3	2	1
Joints tight	4	3	2	1

## AVERAGE RATING

**Evaluator note:** To obtain an average rating for the Profile of Training Mastery, total the points in Product Evaluation and divide by the total number of criteria. Circle the rating on the Key.

## KEY

- 4 Skilled** — Can perform job with no additional training
- 3 Moderately Skilled** — Has performed job during training program; limited additional training may be required
- 2 Limited Skill** — Has performed job during training program; additional training is required to develop skill
- 1 Unskilled** — Is familiar with process, but is unable to perform job

## EVALUATOR'S COMMENTS

---

---

---





# **FIREPROOF ENCASEMENT FORMS**

**CARPENTRY SERIES**



**FIREPROOF ENCASEMENT FORMS  
CARPENTRY SERIES  
JOB SHEET**

Student Name: \_\_\_\_\_ Score: \_\_\_\_\_

**CONSTRUCT AND STRIP FIREPROOF ENCASEMENT FORMS  
FOR BEAMS.**

**BASIC SKILLS**



**INTRODUCTION**

This job sheet gives the procedure for constructing a fireproof encasement form for a beam. At the job site, these forms would be integrated into the joist and decking for a flat above-grade slab.

Form release agent is applied to the inside of reusable forms to prevent the absorption of water, assist in keeping the forms in shape when not in use, and to make their removal much simpler. Refer to manufacturer's specifications as to type of form oil required.

Always use the rules for the care and safe use of power tools when operating power equipment.

**EQUIPMENT AND SUPPLIES**

- 1 x 4s for bottom plates and cleats
- 2" thick material or plywood for beam bottom
- 2 x 4s for ledger support legs
- 2 x 4s for studs, top plates, and kickers
- 2 x 6s for ledgers
- 4 x 4s for stringers

- 8d and 16d duplex nails
- Circular saw and extension cord
- Column clamps
- Concrete nails or powder-actuated pins
- Drill bits
- Form release agent
- Hammer
- Handsaw
- Personal protective equipment
- Plywood sheathing
- Powder-actuated fastener
- Power drill
- Soffit spacers
- Steel tape
- String line

## PROCEDURE

Yes No

- |                          |                          |   |
|--------------------------|--------------------------|---|
| <input type="checkbox"/> | <input type="checkbox"/> | 1. Put on personal protective equipment.                  |
| <input type="checkbox"/> | <input type="checkbox"/> | 2. Lay out material.                                      |
| <input type="checkbox"/> | <input type="checkbox"/> | 3. Determine the size of the beam from the plan drawings. |
|                          |                          | 4. Build the beam bottom.                                 |
| <input type="checkbox"/> | <input type="checkbox"/> | A. Select the type of beam bottom to be constructed.      |

**NOTE ►** The beam bottom may be built with 2x solid material or with a built-up bottom of plywood and 2x runners. See Figure 215.

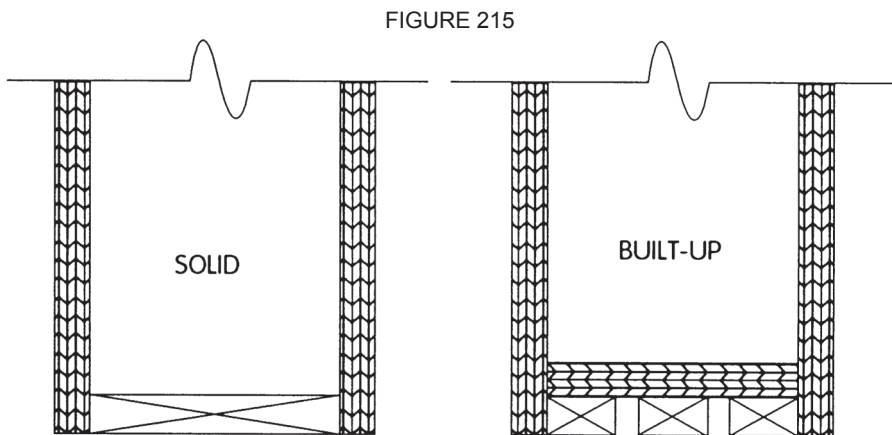



Yes No

B. Drill the holes for the hanger in the beam bottom.

C. Drill the holes in the stringer to match the cross spacing in the beam bottom.

5. Hang the beam bottoms.

A. Place the beam hanger over the steel beam close to the end of the first section of the beam bottom.

B. Line up the holes for the hangers in the stringer.

C. Nail a stringer to the beam bottom on the end away from the column.

D. Drive the soffit spacers into the beam bottom.

E. Refer to the manufacturer's specifications and apply the form release agent.

F. Raise the beam bottom and insert the beam hangers into the predrilled holes.

G. Install the fasteners on the hangers below the stringer. See Figure 216.

FIGURE 216

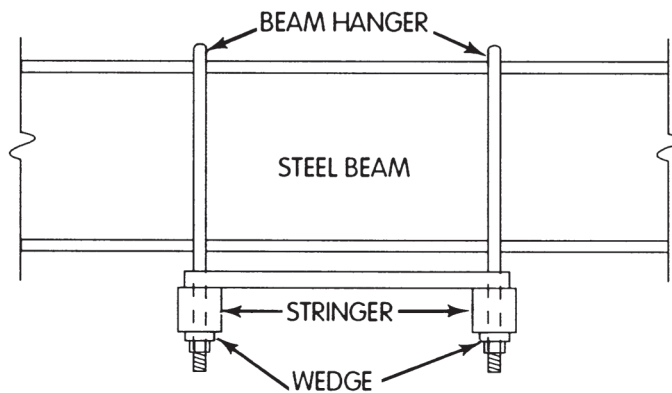

H. Install the intermediate beam hangers.

I. Repeat steps B through H.

Yes No

6. Construct the beam sides. See Figure 217.

A. Cut the beam plywood to size.

**NOTE** ▶ The beam side should sit on the stringer and the decking should sit on the beam side.

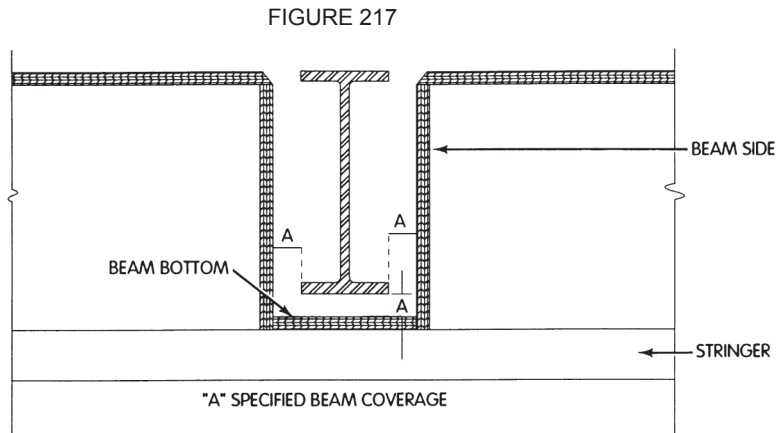

B. Cut the beam sides.

C. Cut the beam studs the height of the beam side minus the top and bottom plates and the decking thickness.

D. Assemble the beam sides.

- 1) Lay out the stud spacing on the plate.
- 2) Nail the studs to the plates.
- 3) Nail the sheathing to the studs.

7. Refer to manufacturer's specifications and apply the form release agent.

8. Install the beam sides, kicker, and ledger. See Figure 218.



FIGURE 218

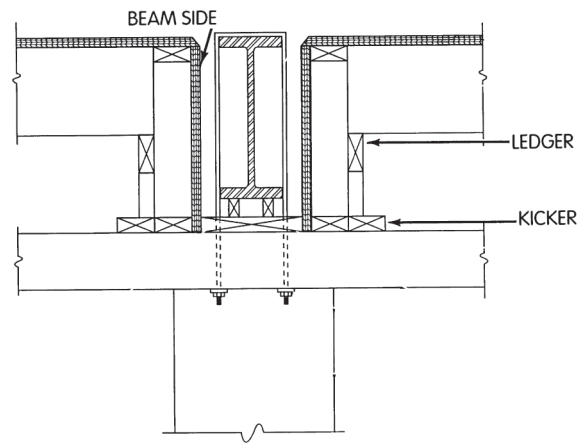

Yes No

A. Nail the beam side to the beam bottom.

B. Nail the continuous kicker to the stringer.

C. Nail the ledger to the beam studs, locating it so that the top of the joist is flush with the top of the beam side.

D. Cut the ledger support legs to the length and nail it to the studs.

E. Align the top of the beam.

1) Inset the spacer between the form and flange of the beam to establish the correct width.

2) Nail a cleat across the top of the beam sides to hold the beam in the correct alignment.

**NOTE ►** The forms are now ready to receive the joist and decking for a flat slab.

9. Ask your instructor to evaluate your work.

10. Strip the form in the reverse order of its construction.

11. Clean up area and put away equipment and supplies.



## PRODUCT EVALUATION

### SKILL TEST RECORD

**Evaluator note:** Rate the student on the following criteria by circling the appropriate numbers. Each criterion must receive a rating of “3” or higher to demonstrate student mastery. (See Key below.) A student who is unable to demonstrate mastery should review the material and submit another product for evaluation.

Criteria:

Safety equipment used properly	4	3	2	1
Beam size correct ( $\frac{1}{4}$ "	4	3	2	1
Beam bottom level ( $\pm\frac{1}{4}$ "	4	3	2	1
Beam sides are plumb and straight	4	3	2	1
Hangers installed properly	4	3	2	1
Form joints tight	4	3	2	1
Stringer holes align with beam bottom	4	3	2	1

### AVERAGE RATING

**Evaluator note:** To obtain an average rating for the Profile of Training Mastery, total the points in Product Evaluation and divide by the total number of criteria. Circle the rating on the Key.

### KEY

- 4 **Skilled** — Can perform job with no additional training
- 3 **Moderately Skilled** — Has performed job during training program; limited additional training may be required
- 2 **Limited Skill** — Has performed job during training program; additional training is required to develop skill
- 1 **Unskilled** — Is familiar with process, but is unable to perform job





## EVALUATOR'S COMMENTS

---

---

---



# **COMMERCIAL DOOR INSTALLATION**

**CARPENTRY SERIES**



COMMERCIAL DOOR INSTALLATION  
CARPENTRY SERIES  
**JOB SHEET**

1

Student Name: \_\_\_\_\_ Score: \_\_\_\_\_

**INSTALL A METAL THRESHOLD ON A CONCRETE FLOOR.**

**BASIC SKILLS**



**INTRODUCTION**

Installing a metal threshold on a concrete floor requires attention to the door opening and threshold measurements. Metal thresholds are manufactured in various heights and widths with door openings ranging from standard to customized sizes. The threshold is usually positioned so that the closed door is approximately centered over the door opening. Metal thresholds may have a vinyl insert used to adjust the height of the threshold and provide a seal for the door. Always refer to the threshold manufacturer's installation instructions for the exact procedure.

**EQUIPMENT AND SUPPLIES**

- Caulking gun and caulk
- Concrete screw anchors
- Drill with masonry bits
- Extension cord
- Hacksaw
- Personal protective equipment
- Metal threshold and manufacturer's installation instructions
- Screwdriver
- Screws
- Steel tape

## PROCEDURE

Yes No

- |                          |                          |  |
|--------------------------|--------------------------|--|
| <input type="checkbox"/> | <input type="checkbox"/> | 1. Put on appropriate personal protective equipment.   |
| <input type="checkbox"/> | <input type="checkbox"/> | 2. Read the manufacturer's installation instructions before starting work.   |
| <input type="checkbox"/> | <input type="checkbox"/> | 3. Measure the door opening between the side jambs and transfer the measurement to the threshold.                              |
| <input type="checkbox"/> | <input type="checkbox"/> | 4. Use a hacksaw to cut the threshold to the desired length as required for proper fit.  |
|                          |                          | 5. Cut the opening for the doorstops.  |
| <input type="checkbox"/> | <input type="checkbox"/> | A. Measure the thickness of the doorstop.  |
| <input type="checkbox"/> | <input type="checkbox"/> | B. Mark the thickness of the doorstop from each end.   |
| <input type="checkbox"/> | <input type="checkbox"/> | C. Cut along the line at the mark deep enough to allow for the doorstop when the closed door is centered over the weatherseal. |

**NOTE** ► The threshold should be positioned so that the closed door is approximately centered over the weatherseal. See figure 219.

FIGURE 219

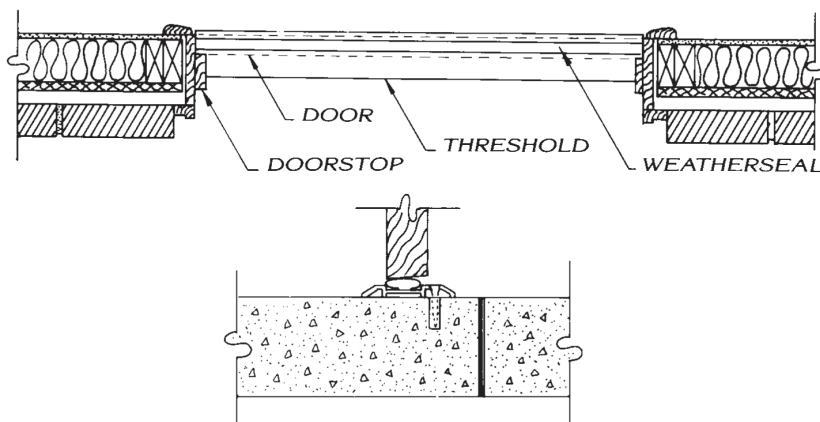

- |                          |                          |   |
|--------------------------|--------------------------|---|
| <input type="checkbox"/> | <input type="checkbox"/> | D. Cut in from each end to provide the notch for doorstops. |
| <input type="checkbox"/> | <input type="checkbox"/> | 6. Place the threshold in position to check for proper fit. |



**Yes No**

- 7. With the threshold in proper position, mark along each edge of the threshold and through screw holes onto the concrete floor.
- 8. Remove threshold.
- 9. Drill holes into the concrete at each screw location, using the proper drill and bit for the anchors being used.
- 10. Clean out each hole, insert anchor in each hole, and tap in place.
- 11. Run a small bead of caulk along the inside of each of the two marked lines on the floor, approximately where the edges of the threshold will rest, and run a bead of caulking material along the ends of the threshold.
- 12. Press the threshold into place.
- 13. Start all screws before tightening evenly.
- 14. Clean up caulk that may have squeezed from under the threshold.
- 15. Clean up area and put away equipment and supplies.

## PRODUCT EVALUATION

### SKILL TEST RECORD

**Evaluator note:** Rate the student on the following criteria by circling the appropriate numbers. Each criterion must receive a rating of “3” or higher to demonstrate student mastery. (See Key below.) A student who is unable to demonstrate mastery should review the material and submit another product for evaluation.

Criteria:

Observe safety procedures	4	3	2	1
Threshold positioned properly	4	3	2	1
Threshold secure	4	3	2	1
Caulking properly applied	4	3	2	1



## AVERAGE RATING

**Evaluator note:** To obtain an average rating for the Profile of Training Mastery, total the points in Product Evaluation and divide by the total number of criteria. Circle the rating on the Key.

## KEY

- 4 **Skilled** — Can perform job with no additional training
- 3 **Moderately Skilled** — Has performed job during training program; limited additional training may be required
- 2 **Limited Skill** — Has performed job during training program; additional training is required to develop skill
- 1 **Unskilled** — Is familiar with process, but is unable to perform job

## EVALUATOR'S COMMENTS

---

---

---

Student Name: \_\_\_\_\_ Score: \_\_\_\_\_

**INSTALL A METAL KNOCKDOWN-TYPE DOOR FRAME.**

**BASIC SKILLS**



**INTRODUCTION**

A metal knockdown-type door frame (KD) is a preassembled door frame with just the exterior casing or brick mold applied. The rough opening for the door will need to be prepared to receive the frame. The door opening is somewhat larger each way, usually 3" wider and 2" higher, than the door. This may require adjustments that include trimming the floor joists.

Some preassembled door frames offer conveniences and details that can assist the carpenter with the installation of the door frame. For instance, a preassemble door frame may offer an adjustable sill, eliminating the trimming of the floor joists. Or, a metal threshold may have vinyl insert to accommodate better fit.

Always refer to the metal knockdown manufacturer's installation instructions for exact procedure.

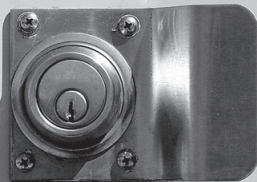

## EQUIPMENT AND SUPPLIES

- Floor plan
- Framing square
- Hammer
- Hand level
- Metal KD door frame including corner clips
- Metal KD manufacturer's installation instructions
- Personal protective equipment
- Screwdriver
- Screws
- Spacing bar
- Steel tape

## PROCEDURE

Yes No

1. Put on appropriate personal protective equipment.
2. Read the metal KD manufacturer's installation instructions before starting work.
3. Check the floor plans.
4. Check the layout on the floor to make sure all lines are correct.
5. Measure the door opening between the side jambs and the top and bottom of the opening. See Figure 220.

FIGURE 220

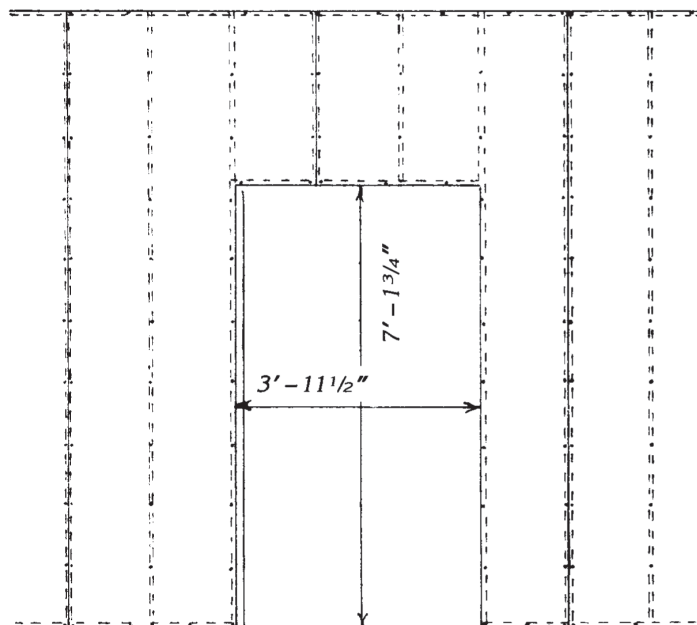

Yes No

- 6. Check the KD door frame size for proper fit.
- 7. Retract the compression bars in the jamb.
- 8. Install one side jamb in its proper position.
- 9. Insert the head jamb under the corner clips on the jamb and raise it into position.
- 10. Insert the corner clips of the other side jamb into the opposite end of the head jamb and move the jamb into its proper position.

FIGURE 221

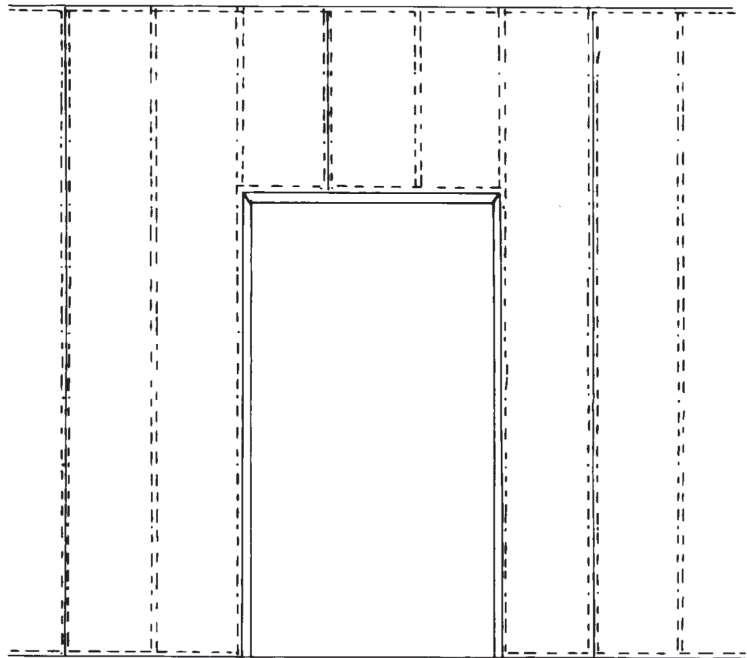

- 11. Locate the frame spacing bar at the base of the frame to maintain the proper opening width.
- 12. Square and plumb the frame.
- 13. Install the base anchor screws through holes in the frame face and into the floor plates.
- 14. Square the top of the frame and tighten the compression bars by carefully turning the screws counter-clockwise without overtightening.

Yes No

15. Install sheet metal screws at the corners of the head jamb.
16. Clean up area and put away equipment and supplies.

## PRODUCT EVALUATION

### SKILL TEST RECORD

**Evaluator note:** Rate the student on the following criteria by circling the appropriate numbers. Each criterion must receive a rating of “3” or higher to demonstrate student mastery. (See Key below.) A student who is unable to demonstrate mastery should review the material and submit another product for evaluation.

Criteria:

Observed safety procedures	4	3	2	1
Head Jamb positioned properly	4	3	2	1
Clips secure	4	3	2	1
Door frame plumb	4	3	2	1

## AVERAGE RATING

**Evaluator note:** To obtain an average rating for the Profile of Training Mastery, total the points in Product Evaluation and divide by the total number of criteria. Circle the rating on the Key.

## KEY

- 4 Skilled** — Can perform job with no additional training
- 3 Moderately Skilled** — Has performed job during training program; limited additional training may be required
- 2 Limited Skill** — Has performed job during training program; additional training is required to develop skill
- 1 Unskilled** — Is familiar with process, but is unable to perform job

**EVALUATOR'S COMMENTS**

---

---

---





COMMERCIAL DOOR INSTALLATION  
CARPENTRY SERIES  
**JOB SHEET**

**3**

Student Name: \_\_\_\_\_ Score: \_\_\_\_\_

**INSTALL AN ENTRY DOOR FRAME, CASING, DOOR, AND LOCK.**

**BASIC SKILLS**



**INTRODUCTION**

This exercise will allow you to develop the skills to install an entry door into a rough opening as well as install the casing and door hardware. The same procedure can be used to install interior doors as well.

**EQUIPMENT AND SUPPLIES**

- 1 x 6 door spreader
- 10d casing nails
- 30" or 78" hand level or jamb level
- 4d, 6d, and 8d finishing nails
- Butt hinges
- Circular saw
- Claw hammer
- Cylindrical lockset with template and manufacturer's installation instructions
- Door
- Door casing
- Door frames
- Door jack
- Door-hanging kit
- Drill and drill bits
- Extension cord
- Flat-blade screwdrivers
- Framing square
- Handsaw



- Nail sets
- Personal protective equipment
- Phillips screwdrivers
- Power miter saw
- Power planer
- Router
- Sawhorses, one pair
- Self-centering punch
- Shims
- Steel tape
- Wood chisels

## PROCEDURE

Yes No

1. Put on personal protective equipment.
2. Check the rough opening for proper dimensions.  
**NOTE** ► Rough openings should be the same size as the door size plus 2½" width and 2" height. The standard thickness for the side jamb is ¾".
3. Check the trimmer studs for plumb.
4. Make sure the floor is level.
5. Assemble and install the door frame.  
**NOTE** ► Check the length of the side jambs with the rough opening. Sometimes it is necessary to cut off part of the lug on the top of the side jambs before assembling. Do not cut off too much of the lug or the assembled frame will not be strong enough.
- A. Fit the head jamb into the dado on the side jambs; glue and nail together with 6d galvanized nails.  
**NOTE** ► If using hardwood drill pilot holes for the nails.
- B. Place the frame in the rough opening.
- C. Center the frame over the opening with the side jambs resting on the floor
- D. Place a spreader on the floor between the side jambs.  
**NOTE** ► The spreader should be the same length as the header between the two side jambs.





Yes No

E. Check to see that the installation is properly aligned and the header is level.

F. Determine the swing of the door from the plans and mark the hinge side on the frame.

G. Secure the frame in the opening using shims at the top and the bottom on both sides of the frame, checking to make sure it is straight and plumb.

H. Adjust the shims to plumb and square the jambs.

I. Temporarily nail side jambs in place remembering not to drive the nails all the way in.

J. Insert shims at each hinge location to adjust for proper clearance.

**NOTE** ► Typically, the top of the upper hinge is located 7" down from the top of the frame, the bottom of the lower hinge is 11" up from the bottom of the door, and if a third hinge is used it is centered between the top and bottom hinges.

K. Use 8d case or finish nails and drive two nails side by side to secure the shims and to keep the jamb from twisting

L. Follow the same procedure to secure the other side of the jamb making sure to shim the jamb at the strike location.

M. Use intermediate shims wherever needed to make the jamb plumb and square.

N. Recheck the door frame for level, plumb, and square.

O. Trim the shims.

6. Prepare door for installation.

A. Place the door in the door jack.

B. Use a power planer or hand plane to cut the proper bevel.

Yes No

C. Nail temporary stop blocks on the side jambs to keep the door from going through the hole when you fit it to the opening.

D. Remove the door from the door jack and fit the door to the opening.

**NOTE** ▶ The clearance should be  $\frac{1}{8}$ " on the lock side and  $\frac{1}{32}$ " on the hinge side. Leave  $\frac{1}{8}$ " clearance on top and between  $\frac{1}{2}$ " and  $\frac{5}{8}$ " on the bottom. The bottom of the door may need to be trimmed later depending on the floor finish.

E. Bevel the edge of the door on the lock side to approximately 3 to 5 degrees.

7. Install the butt hinges and hang door.

**NOTE** ▶ See the manufacturers instructions for the proper assembly of the router hinge template.

A. Position the router template on the hinge edge of the door.

B. Adjust the template to each hinge location.

C. Set the router for the proper depth of cut.

**NOTE** ▶ Check the manufacturers safety instruction before using the router and bit.

D. Use the router to cut gains for the butt hinges.

E. Remove the template from the door.

**NOTE** ▶ Square the corners if using square butt hinges.

F. Drill the holes at the screw locations.

G. Install the hinges on the door with the loose pins toward the top of the door.

H. Attach the router template to the doorjamb, positioning it to make the matching cuts on the jamb.



Yes No

I. Use the router to cut gains on the doorjamb.

J. Remove the template and drill the holes at the screw locations.

K. Using the free leaf repeat the same installation procedure for the butt hinge on the doorjamb.

L. Remove the door from the door jack and hang it in place.

M. Check the clearance between the door and the doorjamb and make necessary adjustments.

8. Install doorstops.

**NOTE** ► The doorstop is installed with square cuts from one side jamb to the other. Next, the side doorstop is installed with a cope joint at the top and a bevel as the bottom.

A. Measure and cut head stop to size.

B. With the door closed, install the head doorstop with the top against the door on the lock side and  $\frac{1}{16}$ " away from the door on the hinge side; tack the head doorstop in place.

C. Cut a cope joint on top of the side doorstops and check for accuracy over the head doorstop.

D. Cut a bevel on the side doorstops leaving between  $\frac{1}{2}$ " to  $\frac{5}{8}$ " clearance from the floor.

E. Tack the side doorstops in place allowing  $\frac{1}{16}$ " clearance on the hinge side and on the lock side.

9. Install the casing.

**NOTE** ► The casing may be installed with the header casing first or the side jambs first. For this exercise we will install the side casing first

A. Mark on the doorjamb an appropriate margin between the jamb and the casing

B. Set a piece of casing on the floor and mark the position of the miter. This is the measurement for the heel of the miter.

Yes No

C. Miter cut the casing and check it for accuracy.

D. Tack the casing in place.

E. Cut the casing for the opposite side of the door and tack it into place.

F. To install the head casing cut a miter on one end of the casing stock.

G. Hold the casing upside down on top of the side casing and mark the toe of the miter. This will be the longest portion of the head casing.

H. Cut the second miter on the head casing.

I. Check for accuracy and make any adjustment.

J. Install the head casing by placing a small amount of adhesive on the miter joints.

**NOTE** ► If using hardwood, drill pilot holes to keep from splitting the wood.

K. Nail the head and side casing with 4d finish nails on the jamb side and 6d finish nails on the wall side. Nail near the ends and about every 16".

**NOTE** ► Nailing too close to the end will split the wood.

L. Use a damp cloth to wipe excess adhesive from the miters if needed.

M. Use a nail set to set all exposed nailheads in the frame and the casing.

10. Install the lockset.

A. Mark the height of the lock.

**NOTE** ► For this exercise we measure 36" from the floor and mark the door at this point.

B. Wedge the door open so it won't move.

C. If using a template fold the lockset template over the edge of the door at the height line.



**Yes**   **No**

D. Mark the center of the strike hole on the door edge and the lockset hole on the face of the door.

E. If using a boring jig you will not need the template.

F. Bore the lockset holes through the door boring half way through on both sides of the door and drill the latch hole through the door edge.

G. Mark the location of the latch plate on the door and chisel or route out the mortise.

H. Mark the height and the vertical center for the strike plate and use the center strike template to mark the center point for the boring jig.

I. Drill the hole for the strike plate.

J. Cut the mortise for the strike plate and install the strike plate.

K. Install the latch unit.

L. Install the lockset by following manufacturer's instructions.

M. Remove the wedge from the door and make sure the lock works properly.

N. Adjust doorstop if required.

O. Set all doorstop nails.

11. Clean up area and put away equipment and supplies.

# PRODUCT EVALUATION

## SKILL TEST RECORD

**Evaluator note:** Rate the student on the following criteria by circling the appropriate numbers. Each criterion must receive a rating of "3" or higher to demonstrate student mastery. (See Key below.) A student who is unable to demonstrate mastery should review the material and submit another product for evaluation.

Criteria:

Side jambs plumb ( $\frac{1}{16}$ "	4	3	2	1
Side jambs straight ( $\frac{1}{16}$ "	4	3	2	1
Casing miter fitted ( $\frac{1}{32}$ "	4	3	2	1
Door clearance correct ( $\frac{1}{32}$ "	4	3	2	1
Door bevel correct ( $\frac{1}{32}$ "	4	3	2	1
Hinges at proper location ( $\frac{1}{16}$ "	4	3	2	1
Hinge flush with door ( $\frac{1}{32}$ "	4	3	2	1
Doorstop in correct position ( $\frac{1}{16}$ "	4	3	2	1
Lock at correct position ( $\frac{1}{16}$ "	4	3	2	1
Lock tightly fit ( $\frac{1}{16}$ "	4	3	2	1

## AVERAGE RATING

**Evaluator note:** To obtain an average rating for the Profile of Training Mastery, total the points in Product Evaluation and divide by the total number of criteria. Circle the rating on the Key.

**KEY**

- 4 **Skilled** — Can perform job with no additional training
- 3 **Moderately Skilled** — Has performed job during training program; limited additional training may be required
- 2 **Limited Skill** — Has performed job during training program; additional training is required to develop skill
- 1 **Unskilled** — Is familiar with process, but is unable to perform job

**EVALUATOR’S COMMENTS**

---

---

---

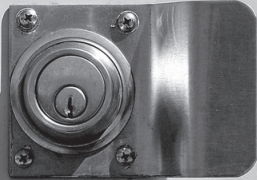





Student Name: \_\_\_\_\_ Score: \_\_\_\_\_

**INSTALL AN EXTERIOR PREHUNG DOOR UNIT.**

**BASIC SKILLS**



**INTRODUCTION**

This exercise will allow you to develop the skills to install an exterior prehung door unit. The best time to have the prehung doors delivered is after the concrete or plaster is dry. Since these doors are relied upon to perform many functions it is best to guard them against the elements. Always check each door to determine straightness and appearance. The hinge that is used most commonly on exterior doors is the loose-pin butt mortise hinge. The size of the hinge is designated by the length of a leaf in inches. The most common size of hinge recommended is a 3½" or a 4" hinge.

**EQUIPMENT AND SUPPLIES**

- 16d and 8d casing nails
- 30", 4', or 6' hand levels
- 4d and 6d finishing nails
- Caulking gun and sealer
- Claw hammer
- Fiberglass insulation or sill sealer
- Framing square
- Nail sets
- Personal protective equipment
- Prehung door and manufacturer's installation instructions
- Shims
- Steel tape

## PROCEDURE

Yes No

- |                          |                          |   |
|--------------------------|--------------------------|---|
| <input type="checkbox"/> | <input type="checkbox"/> | 1. Put on appropriate personal protective equipment.  |
| <input type="checkbox"/> | <input type="checkbox"/> | 2. Check the prehung door manufacturer's installation instructions for exact procedure.   |
| <input type="checkbox"/> | <input type="checkbox"/> | 3. Remove crate from door unit and check for damage.  |
| <input type="checkbox"/> | <input type="checkbox"/> | 4. Check the rough opening for proper dimensions.<br><b>NOTE ►</b> Rough openings should be the same size as the door size plus 2¼" width and 2⅝" height. The standard thickness for the side jamb is ⅝". |
| <input type="checkbox"/> | <input type="checkbox"/> | 5. Check the trimmer studs for plumb.   |
| <input type="checkbox"/> | <input type="checkbox"/> | 6. Make sure the floor is level.  |
| <input type="checkbox"/> | <input type="checkbox"/> | 7. Check the building plans to determine which edge of the door is the hinge edge and which is the lock edge.   |
| <input type="checkbox"/> | <input type="checkbox"/> | 8. Mark both door edges as hinge and lock edges.  |
| <input type="checkbox"/> | <input type="checkbox"/> | 9. Center the door unit temporarily in the opening.   |
| <input type="checkbox"/> | <input type="checkbox"/> | 10. Check to see that the threshold is level and the outside trim is tight against the wall.<br><b>NOTE ►</b> Adjust the level of the opening with shims where required.                                  |
| <input type="checkbox"/> | <input type="checkbox"/> | 11. With the door unit in the proper position, mark along inside edge of threshold.   |
| <input type="checkbox"/> | <input type="checkbox"/> | 12. Remove the door unit from the opening.  |
| <input type="checkbox"/> | <input type="checkbox"/> | 13. Run a bead of caulk on the floor inside the marked line, approximately where the edges of the threshold will rest and run a bead at the jamb-end locations.   |
| <input type="checkbox"/> | <input type="checkbox"/> | 14. Set the door unit back in the center of the rough opening.  |
| <input type="checkbox"/> | <input type="checkbox"/> | 15. Open the door and recheck the threshold for the level.  |
| <input type="checkbox"/> | <input type="checkbox"/> | 16. Check the header for level.   |



**Yes**   **No**

17. Temporarily nail the side jambs into place, taking care not to drive the nails all the way in.

18. Plumb the hinge jamb by inserting shims at the top of the hinge jamb and slightly above the threshold.

19. Nail the jamb into position through the shims and into the trimmer studs.

20. Adjust for proper clearance by inserting shims at each hinge.

21. Nail the jamb through the hinge shims.

**NOTE** ▶ One screw may be removed and replaced with a long screw that will help anchor the jamb to the rough frame.

22. Insert the shims on the lock jamb, starting at top, then the bottom, then to center at strike location.

23. Nail the jamb to the rough framing through each set of shims.

**NOTE** ▶ It may be necessary to add two more sets of shims between the top and the center and the center and the bottom in order to adjust to the proper clearance.

24. Close door and recheck for proper clearance.

25. Cut off the shims that may protrude outside of the frame.

26. Nail the exterior trim using 8d casing nails spaced about 16" apart.

27. Fill the opening between jamb and trimmer studs with fiberglass insulation or sill sealer.

28. Install interior trim and lockset.

29. Adjust the threshold if necessary by following the manufacturer's instructions.

30. Clean up area and put away equipment and supplies.

# PRODUCT EVALUATION

## SKILL TEST RECORD

**Evaluator note:** Rate the student on the following criteria by circling the appropriate numbers. Each criterion must receive a rating of “3” or higher to demonstrate student mastery. (See Key below.) A student who is unable to demonstrate mastery should review the material and submit another product for evaluation.

Criteria:

Observed safety procedures	4	3	2	1
Checked rough opening dimensions	4	3	2	1
Hinge jamb plumb	4	3	2	1
Door operates properly	4	3	2	1
Caulking properly applied	4	3	2	1

## AVERAGE RATING

**Evaluator note:** To obtain an average rating for the Profile of Training Mastery, total the points in Product Evaluation and divide by the total number of criteria. Circle the rating on the Key.

## KEY

- 4 Skilled** — Can perform job with no additional training
- 3 Moderately Skilled** — Has performed job during training program; limited additional training may be required
- 2 Limited Skill** — Has performed job during training program; additional training is required to develop skill
- 1 Unskilled** — Is familiar with process, but is unable to perform job

**EVALUATOR'S COMMENTS**

---

---

---





Student Name: \_\_\_\_\_ Score: \_\_\_\_\_

**INSTALL WEATHERSTRIPPING.**

**BASIC SKILLS**



**INTRODUCTION**

As the cost of heating and cooling increases, weatherstripping becomes a cost effective measure. Weatherstripping is narrow strips of material, such as metal, installed around the doors to retard the passage of air, water, moisture, or dust. The weatherstripping should form a seal that compresses against the closed door. This exercise will allow you to develop the skills to install bronze weatherstripping.

**EQUIPMENT AND SUPPLIES**

- Drill and drill bits
- Extension cord
- Miter
- Personal protective equipment
- Screwdriver
- Screws (usually provided with the weatherstripping)
- Steel tape
- Tin snips
- Utility knife
- Weatherstripping and manufacturer's installation instructions



## PROCEDURE

Yes No

1. Put on appropriate personal protective equipment.

2. Cut the weatherstripping to the desired length.

A. Measure between the two side jambs on the part of the header jamb that is not rabbet or does not include the doorstep.

B. Transfer the measurement to the weatherstripping.

C. Cut the metal part of the weatherstripping with the tin snips; use the utility knife to cut the other material on the miter at both ends.

D. Measure from the floor to the header on the part of the side jambs that is not rabbeted or does not include a doorstep.

E. Transfer the measurements to the weatherstripping.

F. Cut the weatherstripping as described above with the miter at the top.

3. Install the weatherstripping.

**NOTE** ► Weatherstripping should be attached to the center section of the frame, flush with rabbeted edge or doorstep.

A. Position the header jamb weatherstripping on the jamb with the seal material flush with the rabbet edge or doorstep.

B. Mark the location of the screw slots on the doorjamb and on the nail holes in the weatherstripping.

C. If screws are used for installation, remove the weatherstripping and drill appropriate-sized hole in the center of the marked slots.

D. Position the weatherstripping back on the header and install the screws or nails.

**NOTE** ► If weatherstripping has slots for adjustment, do not tighten the screws. Leave the weatherstripping so that when ready it can be slipped into the proper position.





Yes No

E. Use the same procedure described above to install the weatherstripping on the side jambs.

F. Close the door.

G. For adjustable mountings

1) Slide the weatherstripping snug against the door at the header and tighten all of the screws.

2) Slide the weatherstripping snug against the door at the side jambs and tighten all of the screws.

H. Open the door and check the weatherstripping for the proper location.

**NOTE** ► Weatherstripping should protrude approximately  $\frac{1}{8}$ ". For proper fit, the seal should compress against the closed door.

4. Clean up area and put away equipment and supplies.

## PRODUCT EVALUATION

### SKILL TEST RECORD

**Evaluator note:** Rate the student on the following criteria by circling the appropriate numbers. Each criterion must receive a rating of "3" or higher to demonstrate student mastery. (See Key below.) A student who is unable to demonstrate mastery should review the material and submit another product for evaluation.

Criteria:

Observed safety procedures	4	3	2	1
Weatherstripping cut to length	4	3	2	1
Smooth door operation	4	3	2	1

## AVERAGE RATING

**Evaluator note:** To obtain an average rating for the Profile of Training Mastery, total the points in Product Evaluation and divide by the total number of criteria. Circle the rating on the Key.

## KEY

- 4 **Skilled** — Can perform job with no additional training
- 3 **Moderately Skilled** — Has performed job during training program; limited additional training may be required
- 2 **Limited Skill** — Has performed job during training program; additional training is required to develop skill
- 1 **Unskilled** — Is familiar with process, but is unable to perform job

## EVALUATOR'S COMMENTS

---

---

---

COMMERCIAL DOOR INSTALLATION  
CARPENTRY SERIES  
**JOB SHEET**

**6**

Student Name: \_\_\_\_\_ Score: \_\_\_\_\_

**INSTALL DOOR FRAME AND INSIDE JAMBS FOR AN  
OVERHEAD DOOR.**

**BASIC SKILLS**



**INTRODUCTION**

Overhead doors may be either a single-section swing door or multiple sections hinged together. A single section door operates on a pivot principle with the track mounted on the ceiling and rollers located at the center and top of the door. The sectional overhead door has rollers at each section fitted into a track at the side of the door and the ceiling. The sectional overhead door is the most common type used in commercial door installation.

A counter-balance spring is mounted on the sectional overhead door to help support the weight of the door and provide ease of opening. The counter-balance springs may be either torsion or stretch. Always refer to the building plan for exact opening size and requirements. Always refer to the overhead door manufacturer's installation instructions for exact procedures.

## EQUIPMENT AND SUPPLIES

- 12d or 16d galvanized casing nails
- 2 x 6s for inside jambs
- 2 x 7s for door frames
- 6' stepladder
- Caulk
- Caulking gun
- Circular saw
- Claw hammer
- Extension cord
- Framing square
- Level
- Overhead door and manufacturer's specifications
- Personal protective equipment
- Sawhorses, one pair
- Steel tape
- Wood shingles or shims

## PROCEDURE

Yes No

- |                          |                          |   |
|--------------------------|--------------------------|---|
| <input type="checkbox"/> | <input type="checkbox"/> | 1. Put on appropriate personal protective equipment.  |
| <input type="checkbox"/> | <input type="checkbox"/> | 2. Check the rough opening with the size of the overhead door to ensure proper fit.   |
| <input type="checkbox"/> | <input type="checkbox"/> | 3. Check the side jambs for plumb.  |
| <input type="checkbox"/> | <input type="checkbox"/> | 4. Check the header for level and square.   |
|                          |                          | <b>NOTE ►</b> The rough opening should be the same size as the door size, plus the thickness of the frame, plus the clearance.  |
| <input type="checkbox"/> | <input type="checkbox"/> | 5. Cut the door frame members to size.  |
|                          |                          | <b>NOTE ►</b> The header jamb should be the width of the door plus twice the thickness of the side jamb. The side jambs should be the same as the height of the door. |
|                          |                          | 6. Install the finish header jamb.  |
| <input type="checkbox"/> | <input type="checkbox"/> | A. Determine the height of the finish header.   |
| <input type="checkbox"/> | <input type="checkbox"/> | B. Install the header at the desired height, flush with the interior of the wall.   |
| <input type="checkbox"/> | <input type="checkbox"/> | C. Use the shingles to shim the header level.   |
| <input type="checkbox"/> | <input type="checkbox"/> | D. Nail the header in place and check for level.  |

Yes No

7. Install the finish side jambs.

- A. Install the first side jamb flush with the interior wall.
- B. Use the shingles to shim the jamb plumb and square.
- C. Nail the jamb in place and check for plumb and square.
- D. Install the second side jamb in the same manner.
- E. Check the finish opening to see that it is the size of the overhead door.

8. Cut and install the inside casing and track-mounting supports.

**NOTE** ► The inside side casing is installed full length between the floor and ceiling.

- A. Measure the distance between the floor and the ceiling and cut the side casing to this length.
- B. Install the side casing flush with the face of the finish frame.

FIGURE 222

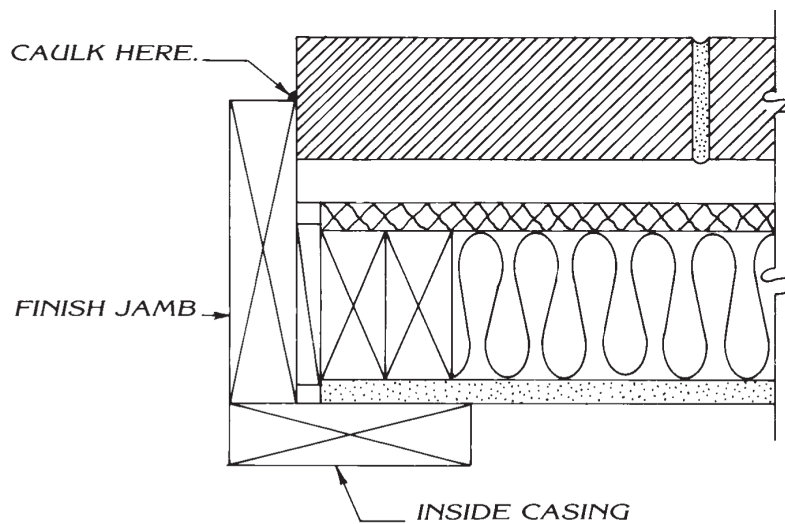

- C. Cut and install the inside header casing between the two side casings and flush with the face of the finish header.

- D. Cut and install the center vertical mounting support between the inside header casing and the ceiling.
- 9. Caulk the outside of the finish door frame between the frame and brick if used.
  - NOTE** ► Doorstops will be furnished and installed by the door hanger.
- 10. Check for level, plumb, and square.
- 11. Clean up area and put away equipment and supplies.

## PRODUCT EVALUATION

### SKILL TEST RECORD

**Evaluator note:** Rate the student on the following criteria by circling the appropriate numbers. Each criterion must receive a rating of “3” or higher to demonstrate student mastery. (See Key below.) A student who is unable to demonstrate mastery should review the material and submit another product for evaluation.

Criteria:

Observed safety procedures	4	3	2	1
Checked rough opening dimensions ( $\pm \frac{1}{16}$ " )	4	3	2	1
Use of shims to level header	4	3	2	1
Casing and track mounting properly installed	4	3	2	1
Smooth door operation	4	3	2	1
Caulking applied	4	3	2	1

### AVERAGE RATING

**Evaluator note:** To obtain an average rating for the Profile of Training Mastery, total the points in Product Evaluation and divide by the total number of criteria. Circle the rating on the Key.

## KEY

- 4 **Skilled** — Can perform job with no additional training
- 3 **Moderately Skilled** — Has performed job during training program; limited additional training may be required
- 2 **Limited Skill** — Has performed job during training program; additional training is required to develop skill
- 1 **Unskilled** — Is familiar with process, but is unable to perform job

## EVALUATOR'S COMMENTS

---

---

---







COMMERCIAL DOOR INSTALLATION  
CARPENTRY SERIES  
**JOB SHEET**

**7**

Student Name: \_\_\_\_\_ Score: \_\_\_\_\_

**INSTALL INTERIOR DOOR FRAME, DOOR, LOCK, AND TRIM.**

**BASIC SKILLS**



**INTRODUCTION**

As with exterior doors, interior doors usually come in flush and panel styles. Most standard interior doors are  $1\frac{3}{8}$ " thick. Common widths for single interior doors are 2' 6" for bedrooms and other habitable rooms. Bathrooms are 2' 4" with small closets and linen closets generally at 2'.

Installing an interior door frame, door, lock, and trim is very similar to installing an exterior door. Always refer to the building plans for specific door hand and specifications. Always follow the manufacturer's instructions and details included with each lockset to install the lockset. Follow the manufacturer's instructions for adjusting the lock.

**EQUIPMENT AND SUPPLIES**

- 30" hand level
- 4d and 6d finish nails
- 6' straight edge or jamb level
- 8d casing nails
- Butt hinges
- Claw hammer
- Door
- Door casing
- Door jack
- Doorjamb

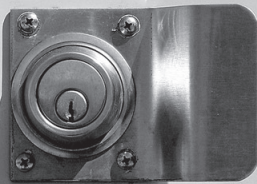

- Door spreader
- Door-hanging kit
- Drill and bits
- Extension cord
- Flat screwdrivers
- Framing square
- Glue
- Hand plane
- Handsaw or circular saw
- Lockset with template
- Nail sets
- Personal protective equipment
- Phillips screwdrivers
- Power miter saws
- Power planer
- Router with hinge-mortising bit
- Sawhorses, one pair
- Self-centering punch
- Shims
- Steel tape
- Utility knife
- Wood chisel

## PROCEDURE

Yes No

1. Put on personal protective equipment.

2. Check the rough opening for proper dimensions.

**NOTE ►** Rough openings should be the same size as the door size plus 2½" width and 2" height. The standard thickness for the side jamb is ¾".

3. Check the trimmer studs for plumb.

4. Make sure the floor is level.

5. Assemble and install the door frame.

**NOTE ►** Check the length of the side jambs with the rough opening. Sometimes it is necessary to cut off part of the lug on the top of the side jambs before assembling. Do not cut off too much of the lug or the assembled frame will not be strong enough.

A. Fit the head jamb into the dado on the side jambs; glue and nail together with 6d galvanized nails.

**NOTE ►** If using hardwood drill pilot holes for the nails.

B. Place the frame in the rough opening.





Yes No

C. Center the frame over the opening with the side jambs resting on the floor and the edges flush with the wall face.

D. Place a spreader on the floor between the side jambs.

**NOTE ►** The spreader should be the same length as the header between the two side jambs.

E. Check to see that the installation is properly aligned and the header is level.

F. Determine the swing of the door from the plans and mark the hinge side on the frame.

G. Secure the frame in the opening using shims at the top and the bottom on both sides of the frame, checking to make sure it is straight and plumb.

H. Adjust the shims to plumb and square the jambs.

I. Temporarily nail side jambs in place remembering not to drive the nails all the way in.

J. Insert shims at each hinge location to adjust for proper clearance.

**NOTE ►** Typically, the top of the upper hinge is located 7" down from the top of the frame, the bottom of the lower hinge is 11" up from the bottom of the door, and if a third hinge is used it is centered between the top and bottom hinges.

K. Use 8d case or finish nails and drive two nails side by side to secure the shims and to keep the jamb from twisting

L. Follow the same procedure to secure the other side of the jamb making sure to shim the jamb at the strike location.

M. Use intermediate shims wherever needed to make the jamb plumb and square.

N. Recheck the door frame for level, plumb, and square.

O. Trim the shims.

Yes No

6. Prepare door for installation.

- A. Place the door in the door jack.
- B. Use a power planer or hand plane to cut the proper bevel.
- C. Nail temporary stop blocks on the side jambs to keep the door from going through the hole when you fit it to the opening.
- D. Remove the door from the door jack and fit the door to the opening.
- NOTE** ▶ The clearance should be  $\frac{1}{8}$ " on the lock side and  $\frac{1}{32}$ " on the hinge side. Leave  $\frac{1}{8}$ " clearance on top and between  $\frac{1}{2}$ " and  $\frac{5}{8}$ " on the bottom. The bottom of the door may need to be trimmed later depending on the floor finish.
- E. Bevel the edge of the door on the lock side to approximately 3 to 5 degrees.

7. Install the butt hinges and hang door.

**NOTE** ▶ See the manufacturers instructions for the proper assembly of the router hinge template.

- A. Position the router template on the hinge edge of the door.
- B. Adjust the template to each hinge location.
- C. Set the router for the proper depth of cut.
- NOTE** ▶ Check the manufacturers safety instruction before using the router and bit.
- D. Use the router to cut gains for the butt hinges.
- E. Remove the template from the door.
- NOTE** ▶ Square the corners if using square butt hinges.
- F. Drill the holes at the screw locations.
- G. Install the hinges on the door with the loose pins toward the top of the door.



Yes No

H. Attach the router template to the doorjamb, positioning it to make the matching cuts on the jamb.

I. Use the router to cut gains on the doorjamb.

J. Remove the template and drill the holes at the screw locations.

K. Using the free leaf repeat the same installation procedure for the butt hinge on the doorjamb.

L. Remove the door from the door jack and hang it in place.

M. Check the clearance between the door and the doorjamb and make necessary adjustments.

8. Install doorstops.

**NOTE** ► The doorstop is installed with square cuts from one side jamb to the other. Next, the side doorstop is installed with a cope joint at the top and a bevel as the bottom.

A. Measure and cut head stop to size.

B. With the door closed, install the head doorstop with the top against the door on the lock side and  $\frac{1}{16}$ " away from the door on the hinge side; tack the head doorstop in place.

C. Cut a cope joint on top of the side doorstops and check for accuracy over the head doorstop.

D. Cut a bevel on the side doorstops leaving between  $\frac{1}{2}$ " to  $\frac{5}{8}$ " clearance from the floor.

E. Tack the side doorstops in place allowing  $\frac{1}{16}$ " clearance on the hinge side and on the lock side.

9. Install the casing.

**NOTE** ► The casing may be installed with the header casing first or the side jambs first. For this exercise we will install the side casing first

A. Mark on the doorjamb an appropriate margin between the jamb and the casing

Yes No

B. Set a piece of casing on the floor and mark the position of the miter. This is the measurement for the heel of the miter.

C. Miter cut the casing and check it for accuracy.

D. Tack the casing in place.

E. Cut the casing for the opposite side of the door and tack it into place.

F. To install the head casing cut a miter on one end of the casing stock.

G. Hold the casing upside down on top of the side casing and mark the toe of the miter. This will be the longest portion of the head casing.

H. Cut the second miter on the head casing.

I. Check for accuracy and make any adjustment.

J. Install the head casing by placing a small amount of adhesive on the miter joints.

**NOTE** ▶ If using hardwood, drill pilot holes to keep from splitting the wood.

K. Nail the head and side casing with 4d finish nails on the jamb side and 6d finish nails on the wall side. Nail near the ends and about every 16".

**NOTE** ▶ Nailing too close to the end will split the wood.

L. Use a damp cloth to wipe excess adhesive from the miters if needed.

M. Use a nail set to set all exposed nailheads in the frame and the casing.

10. Install the lockset.

A. Mark the height of the lock.

**NOTE** ▶ For this exercise we measure 36" from the floor and mark the door at this point.

B. Wedge the door open so it won't move.





**Yes**   **No**

C. If using a template fold the lockset template over the edge of the door at the height line.

D. Mark the center of the strike hole on the door edge and the lockset hole on the face of the door.

E. If using a boring jig you will not need the template.

F. Bore the lockset holes through the door boring half way through on both sides of the door and drill the latch hole through the door edge.

G. Mark the location of the latch plate on the door and chisel or route out the mortise.

H. Mark the height and the vertical center for the strike plate and use the center strike template to mark the center point for the boring jig.

I. Drill the hole for the strike plate.

J. Cut the mortise for the strike plate and install the strike plate.

K. Install the latch unit.

L. Install the lockset by following manufacturer's instructions.

M. Remove the wedge from the door and make sure the lock works properly.

N. Adjust doorstop if required.

O. Set all doorstop nails.

11. Clean up area and put away equipment and supplies.



# PRODUCT EVALUATION

## SKILL TEST RECORD

**Evaluator note:** Rate the student on the following criteria by circling the appropriate numbers. Each criterion must receive a rating of "3" or higher to demonstrate student mastery. (See Key below.) A student who is unable to demonstrate mastery should review the material and submit another product for evaluation.

Criteria:

Side jambs plumb ( $\frac{1}{16}$ "	4	3	2	1
Side jambs straight ( $\frac{1}{16}$ "	4	3	2	1
Casing miter fitted ( $\frac{1}{32}$ "	4	3	2	1
Door clearance correct ( $\frac{1}{32}$ "	4	3	2	1
Door bevel correct ( $\frac{1}{32}$ "	4	3	2	1
Hinges at proper location ( $\frac{1}{16}$ "	4	3	2	1
Hinge flush with door ( $\frac{1}{32}$ "	4	3	2	1
Doorstop in correct position ( $\frac{1}{16}$ "	4	3	2	1
Lock at correct position ( $\frac{1}{16}$ "	4	3	2	1
Lock tightly fit ( $\frac{1}{16}$ "	4	3	2	1

## AVERAGE RATING

**Evaluator note:** To obtain an average rating for the Profile of Training Mastery, total the points in Product Evaluation and divide by the total number of criteria. Circle the rating on the Key.

**KEY**

- 4 **Skilled** — Can perform job with no additional training
- 3 **Moderately Skilled** — Has performed job during training program; limited additional training may be required
- 2 **Limited Skill** — Has performed job during training program; additional training is required to develop skill
- 1 **Unskilled** — Is familiar with process, but is unable to perform job

**EVALUATOR’S COMMENTS**

---

---

---





# CARPENTRY SKILLS WORKBOOK

## PROFILE OF TRAINING MASTERY

Instructor: \_\_\_\_\_ Date: \_\_\_\_\_

Program: \_\_\_\_\_

School: \_\_\_\_\_ Grade: \_\_\_\_\_

Name: \_\_\_\_\_ Soc. Sec. No. \_\_\_\_\_

Address: \_\_\_\_\_ Phone: \_\_\_\_\_

In Case of Emergency, Contact: \_\_\_\_\_

Address: \_\_\_\_\_ Phone: \_\_\_\_\_

Allergies/Disabilities that might require special accommodation for training (please specify):

\_\_\_\_\_

**The above information can be used for school records and/or to ensure safety of students.  
This confidential information is not to be released to employers or the general public.**

Date of Enrollment: \_\_\_\_\_ Date of Withdrawal: \_\_\_\_\_

Date of Completion: \_\_\_\_\_ Total On-the-Job Training Hours: \_\_\_\_\_

Total Class Hours: \_\_\_\_\_ Total Lab Hours: \_\_\_\_\_

Total Hours Tardy: \_\_\_\_\_ Total Hours Absent: \_\_\_\_\_

### ON-THE-JOB TRAINING/WORK EXPERIENCE

Duration of Employment	Job Title	Supervisor's Name
Address of Employer	Phone	

Duration of Employment	Job Title	Supervisor's Name
Address of Employer	Phone	

### Use of This Document

This document can be used to record information about the student and skills mastered. This information is useful in documenting student progress during training and in providing information about the student's qualifications to potential employers and/or for entry into advanced training programs. Instructors using these materials are authorized to reproduce this document as required for use in their training programs.



Copyright 2012  
Curriculum and Instructional Materials Center, Oklahoma Department of Career and Technology Education  
1500 West Seventh Avenue, Stillwater, Oklahoma 74074-4364 800-654-4502 Fax 405-743-5154

# CARPENTRY SKILLS WORKBOOK

## SPECIFIC JOB COMPETENCIES

### INSTRUCTOR:

As each competency is mastered, place your initials and the date in the blank on the left. This will verify that the student can perform the skill with a minimum of supervision.

## RESIDENTIAL CARPENTRY

### RESIDENTIAL DOOR INSTALLATION

- \_\_\_\_\_ Job Sheet 1 Install a metal threshold on a concrete floor.
- \_\_\_\_\_ Job Sheet 2 Install an entry door frame, casing, door, and lock.
- \_\_\_\_\_ Job Sheet 3 Install an exterior prehung door unit.
- \_\_\_\_\_ Job Sheet 4 Install weatherstripping.
- \_\_\_\_\_ Job Sheet 5 Install door frame and inside jambs for an overhead door.
- \_\_\_\_\_ Job Sheet 6 Install a split-jamb prehung door unit.
- \_\_\_\_\_ Job Sheet 7 Install a solid-jamb door unit.
- \_\_\_\_\_ Job Sheet 8 Install interior door frame, door, lock, and trim.
- \_\_\_\_\_ Job Sheet 9 Install a bifold door unit.
- \_\_\_\_\_ Job Sheet 10 Install a pocket door unit.

### RESIDENTIAL ROOF FRAMING

- \_\_\_\_\_ Job Sheet 1 Lay out rafter locations on the top plate and ridgeboard on 2' centers.
- \_\_\_\_\_ Job Sheet 2 Lay out, cut, and install ceiling joists and erect rafters for gable roofs.
- \_\_\_\_\_ Job Sheet 3 Frame a gable end with a vent opening.
- \_\_\_\_\_ Job Sheet 4 Lay out and cut ceiling joists and rafters for hip roofs.
- \_\_\_\_\_ Job Sheet 5 Erect ceiling joists and rafters for hip roofs.
- \_\_\_\_\_ Job Sheet 6 Lay out, cut, and erect rafters for an intersecting hip roof with valley.
- \_\_\_\_\_ Job Sheet 7 Frame an opening in a roof.
- \_\_\_\_\_ Job Sheet 8 Apply roof sheathing.

### WALL AND CEILING FRAMING

- \_\_\_\_\_ Job Sheet 1 Lay out wall partition locations on floor.
- \_\_\_\_\_ Job Sheet 2 Cut studs, trimmers, cripples, and headers to length.
- \_\_\_\_\_ Job Sheet 3 Assemble corners, Ts, and headers.
- \_\_\_\_\_ Job Sheet 4 Construct wall sections.
- \_\_\_\_\_ Job Sheet 5 Lay out and install ceiling joists
- \_\_\_\_\_ Job Sheet 6 Install fiberboard or insulation-panel, drywall, and plywood sheathing.
- \_\_\_\_\_ Job Sheet 7 Install sheathing and plywood siding.

Student ratings on specific competencies evaluated during the course are available upon student's written request and/or by calling the instructor. Parent's or guardian's signature is necessary if student is under 18 years of age.

## STAIR FRAMING

\_\_\_\_\_ Job Sheet     Construct a stair.

## CORNICE AND GABLE ENDS

\_\_\_\_\_ Job Sheet 1     Build a horizontal box cornice.

\_\_\_\_\_ Job Sheet 2     Apply siding to gable end.

## EXTERIOR WALLS AND TRIM

\_\_\_\_\_ Job Sheet 1     Install fiberboard or insulation-panel, gypsum-board, and plywood sheathing.

\_\_\_\_\_ Job Sheet 2     Install bevel siding.

\_\_\_\_\_ Job Sheet 3     Install sheathing and plywood siding.

\_\_\_\_\_ Job Sheet 4     Install vinyl siding.

## CABINETS, SHELVES, AND BUILT-INS

\_\_\_\_\_ Job Sheet 1     Install a factory-built cabinet.

\_\_\_\_\_ Job Sheet 2     Install shelves in a closet.

## FLOOR FINISHING

\_\_\_\_\_ Job Sheet 1     Install underlayment.

\_\_\_\_\_ Job Sheet 2     Install resilient tile.

\_\_\_\_\_ Job Sheet 3     Install tongue-and-groove hardwood strip flooring.

\_\_\_\_\_ Job Sheet 4     Install block flooring.

## ROOF FINISHES

\_\_\_\_\_ Job Sheet 1     Use a roofer's hatchet properly.

\_\_\_\_\_ Job Sheet 2     Use a pneumatic fastener.

\_\_\_\_\_ Job Sheet 3     Apply asphalt shingles with a 5" exposure.

\_\_\_\_\_ Job Sheet 4     Apply wood shingles with a 5" exposure over spaced sheathing.

## COMMERCIAL CARPENTRY

### COLUMN FORMS

\_\_\_\_\_ Job Sheet 1     Construct and strip forms for a square column.

\_\_\_\_\_ Job Sheet 2     Set and strip a round column.

### BEAM FORMS

\_\_\_\_\_ Job Sheet 1     Construct and strip a spandrel beam form.

\_\_\_\_\_ Job Sheet 2     Construct and strip an interior beam form.

\_\_\_\_\_ Job Sheet 3     Construct and strip a plate girder beam form.

### ABOVE-GRADE SLAB SYSTEMS

\_\_\_\_\_ Job Sheet 1     Construct and strip forms for a one-way joist system.

\_\_\_\_\_ Job Sheet 2     Construct and strip forms for a two-way joist system.

\_\_\_\_\_ Job Sheet 3     Construct, set, and strip a flying slab form.

\_\_\_\_\_ Job Sheet 4     Set screeds on a deck for a flat slab.

## **BRIDGE DECK FORMS**

\_\_\_\_\_ Job Sheet     Construct and strip forms for a bridge deck.

## **FIREPROOF ENCASEMENT FORMS**

\_\_\_\_\_ Job Sheet     Construct and strip fireproof encasement forms for beams.

## **COMMERCIAL DOOR INSTALLATION**

\_\_\_\_\_ Job Sheet 1     Install a metal threshold on a concrete floor.

\_\_\_\_\_ Job Sheet 2     Install a metal knockdown-type door frame.

\_\_\_\_\_ Job Sheet 3     Install an entry door frame, casing, door, and lock.

\_\_\_\_\_ Job Sheet 4     Install an exterior prehung door unit.

\_\_\_\_\_ Job Sheet 5     Install weatherstripping.

\_\_\_\_\_ Job Sheet 6     Install door frame and inside jambs for an overhead door.

\_\_\_\_\_ Job Sheet 7     Install interior door frame, door, lock, and trim.